

AFE1256 用于数字 X 射线平板探测器、的 256 通道模拟前端

1 特性

- 256 个通道
- 片上 16 位模数转换器 (ADC)
- 光电二极管抗短路
- 数据线 (列) 抗短路
- 高性能:
 - 噪声: 758 electronRMS (eRMS), 1.2pC 范围内的 28pF 传感器电容器
 - 积分非线性: 内部 16 位 ADC 的 ± 2 最低有效位 (LSB)
 - 最小扫描时间:
 - 正常模式下为 37.9 μ s
 - 2x 双像素模式下为 20 μ s
- 集成:
 - 8 个可选满量程范围: 0.15pC (最小值) 至 9.6pC (最大值)
 - 内置相关双采样器
 - 针对更快速数据吞吐量的 2x 双像素模式 (两个相邻通道的平均充电)
 - 管道式积分和读取: 积分期间允许数据读取
- 灵活性:
 - 电子和空穴积分
- 低功耗:
 - 具有 ADC 时, 每通道 2.9mW
 - 无 ADC 时, 每通道 2.3mW
 - 打盹模式时, 每通道 0.1mW
 - 总断电特性
- 22mm x 5mm 凸出式金属接点芯片, 适用于带载封装 (TCP) 和 覆晶薄膜封装 (COF)

2 应用范围

平板 X 射线探测器

3 说明

AFE1256 是一款 256 个通道模拟前端 (AFE), 此器件被设计成满足基于平板探测器 (FPD) 的数字 X 射线系统的要求。此器件包括 256 个积分器, 一个用于满量程充电电平选择的可编程增益放大器 (PGA), 一个具有双组的相关双采样器 (CDS), 256:4 模拟复用器和四个板载 16 位, 逐次逼近寄存器 (SAR) 模数转换器 (ADC)。ADC 提供格式为 SPI™ 的串行数据。

硬件可选积分极性可实现正或负电荷积分, 并在系统设计中提供更多的灵活性。此打盹特性大大节省了能耗。这一节电特性特别适合于电池供电类系统。

该器件可以 22mm x 5mm 凸出式金属接点芯片形式提供, 也提供 38mm x 28mm、COF-314 TDS 封装。

如需完整数据表或其他设计资源, 请点击: [请求获取 AFE1256](#)

器件信息⁽¹⁾

订货编号	封装	封装尺寸
AFE1256GBTD	凸出式金属接点芯片 (533)	22mm x 5mm
AFE1256TDS	COF (314)	38mm x 28mm

(1) 要了解所有可用封装, 请参见数据表末尾的封装选项附录。

(2) 产品预览器件。

AFE1256 电路原理图

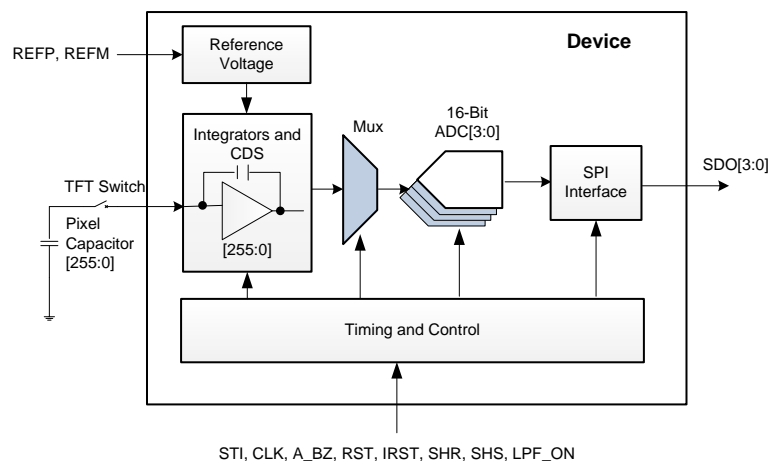

目录

1	特性	1	5.1	商标	3
2	应用范围	1	5.2	静电放电警告	3
3	说明	1	5.3	Glossary	3
4	修订历史记录	2	6	机械封装和可订购信息	3
5	器件和文档支持	3	6.1	托盘尺寸	4
			6.2	GBTD 芯片	5

4 修订历史记录

注：之前版本的页码可能与当前版本有所不同。

Changes from Revision C (August 2015) to Revision D	Page
• 已添加 请求获取完整数据表的链接	1

Changes from Revision B (April 2014) to Revision C	Page
• 已将文档状态从混合改为量产数据	1
• 已从文档中删除 TDQ 封装	1
• 已更改说明部分的最后一段	1
• 已删除器件信息表中的第二行	1
• 已更改托盘尺寸部分：已删除图 1	4

Changes from Revision A (March 2014) to Revision B	Page
• 已将 TDS 封装更改为量产数据	1

Changes from Original (October 2013) to Revision A	Page
• 已更改产品预览数据表	1

5 器件和文档支持

5.1 商标

SPI is a trademark of Motorola.

All other trademarks are the property of their respective owners.

5.2 静电放电警告



这些装置包含有限的内置 ESD 保护。存储或装卸时，应将导线一起截短或将装置放置于导电泡棉中，以防止 MOS 门极遭受静电损伤。

5.3 Glossary

[SLYZ022](#) — *TI Glossary*.

This glossary lists and explains terms, acronyms, and definitions.

6 机械封装和可订购信息

以下页中包括机械、封装和可订购信息。这些信息是针对指定器件可提供的最新数据。这些数据会在无通知且不对本文档进行修订的情况下发生改变。欲获得该数据表的浏览器版本，请查阅左侧的导航栏。

6.1 托盘尺寸

TDS 封装的托盘尺寸如图 1 所示。

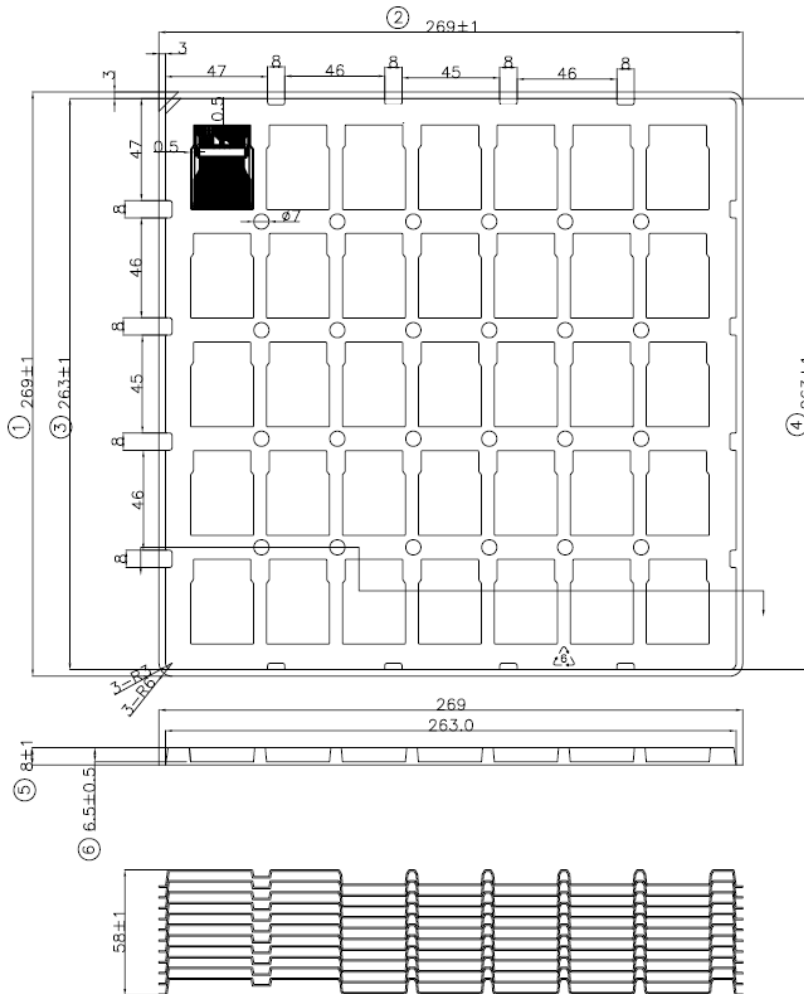

Remark : ⑦
 1. Tray material : PS WHITE PREVENT
 PREVENT CONDUCT ELECTRICITY MATERAIL
 CONDUCT ELECTRICITY VALUE 10 ~10 Ω
 2. Material thickness: 0.70±0.2mm
 3. Singulation orientation: input side toward
 the up and SR towards the top(as drawing).

图 1. TDS 托盘尺寸

6.2 GBTD 芯片

图 2 未考虑划线密封。



图 2. GBTD 芯片机械数据

GBTD 芯片 (接下页)

图 3 提供了 GBTD 芯片的托盘尺寸。

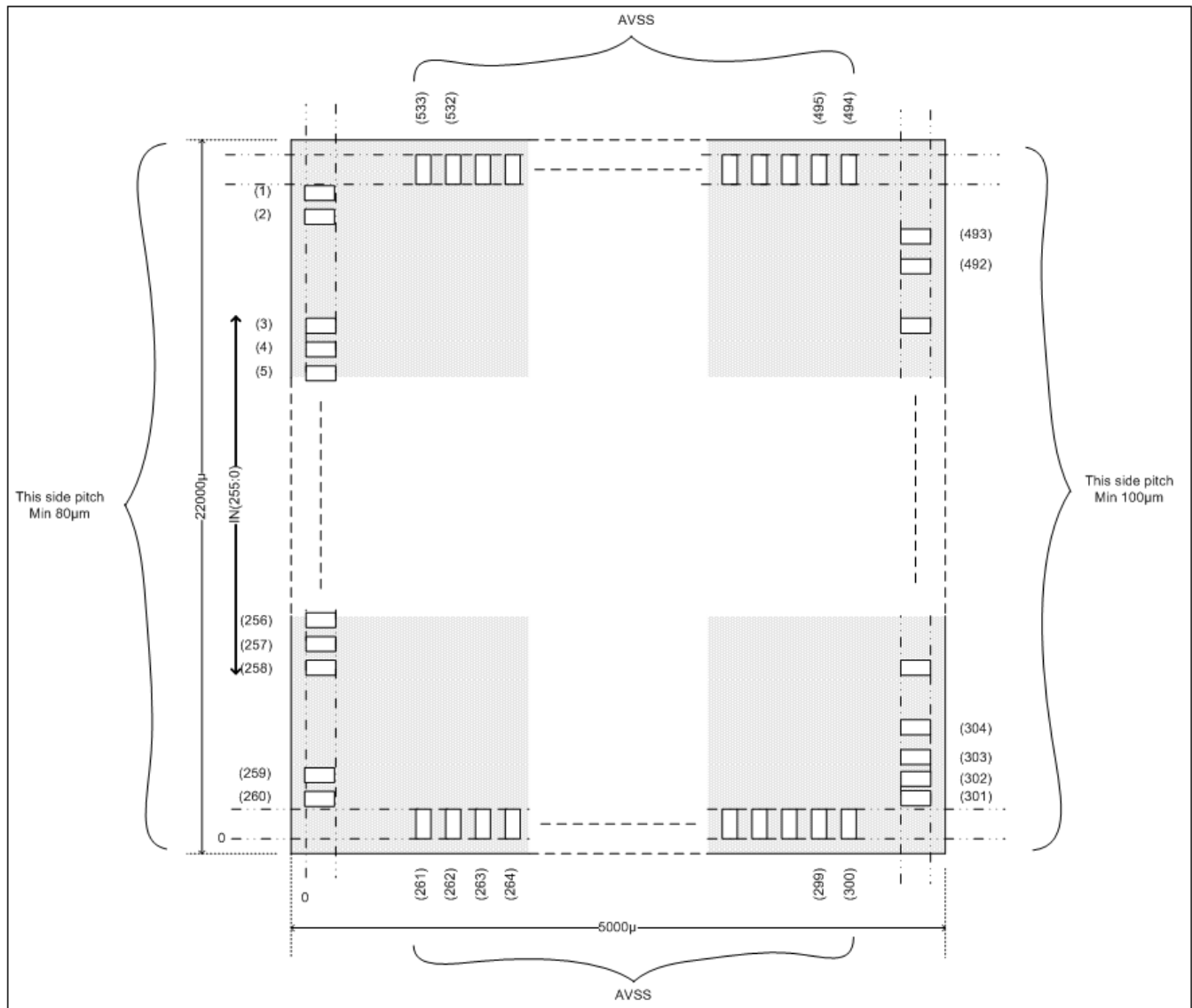

图 3. GBTD 芯片托盘尺寸详细信息

GBTD 芯片 (接下页)

芯片被有源侧朝上（金属接点朝上）放置在晶圆封装中。如 图 4 中所示，晶圆封装缺口在右上部。

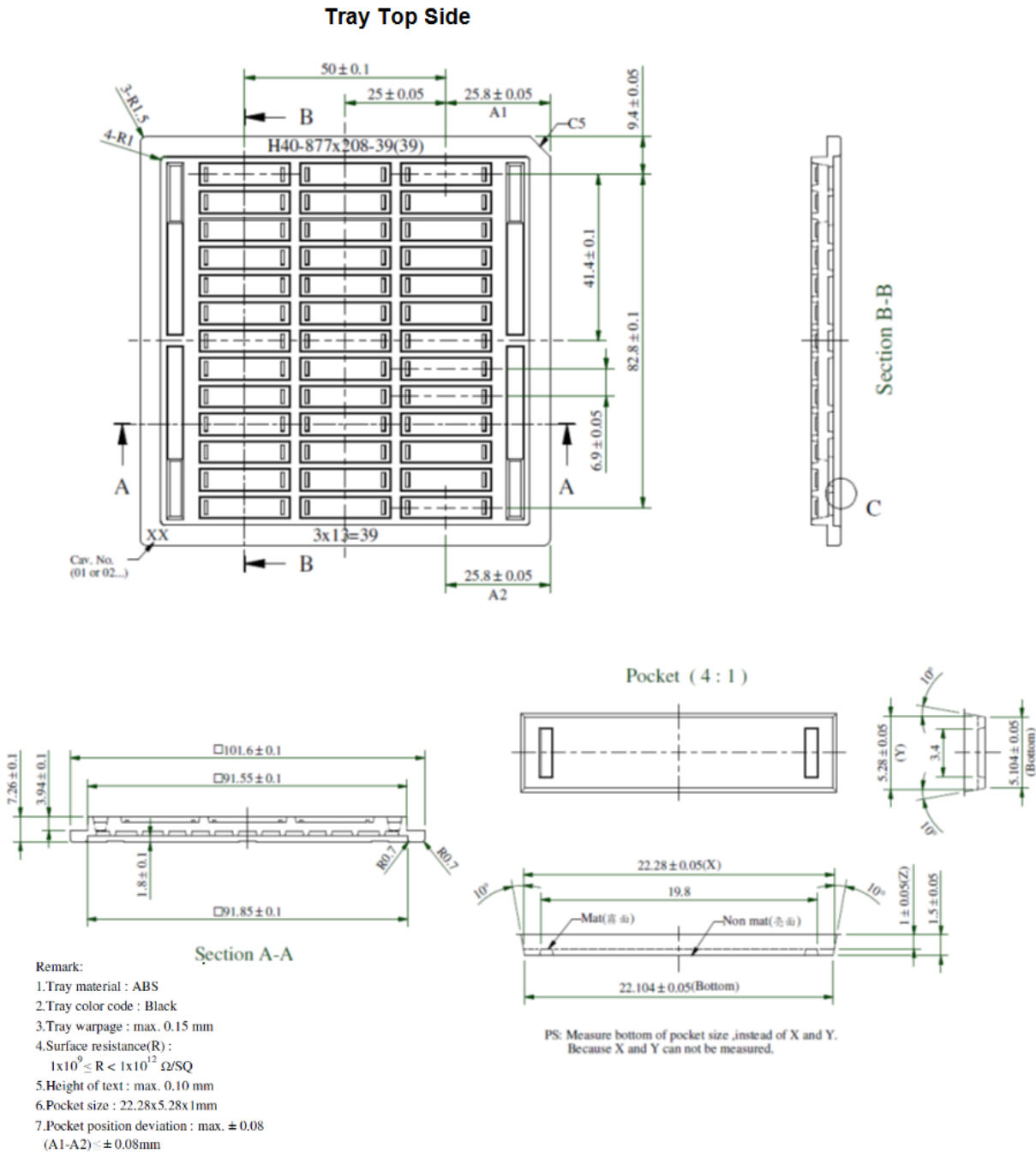

图 4. GBTD 芯片，引脚 1 位置

PACKAGING INFORMATION

Orderable Device	Status (1)	Package Type	Package Drawing	Pins	Package Qty	Eco Plan (2)	Lead finish/ Ball material (6)	MSL Peak Temp (3)	Op Temp (°C)	Device Marking (4/5)	Samples
AFE1256GBTD	ACTIVE			0	39	RoHS & Green	Call TI	Call TI	0 to 70	AFE1256	Samples
AFE1256TDS	ACTIVE	COF	TDS	314	35	RoHS & Green	AU	N / A for Pkg Type	0 to 70	AFE1256TDS	Samples

(1) The marketing status values are defined as follows:

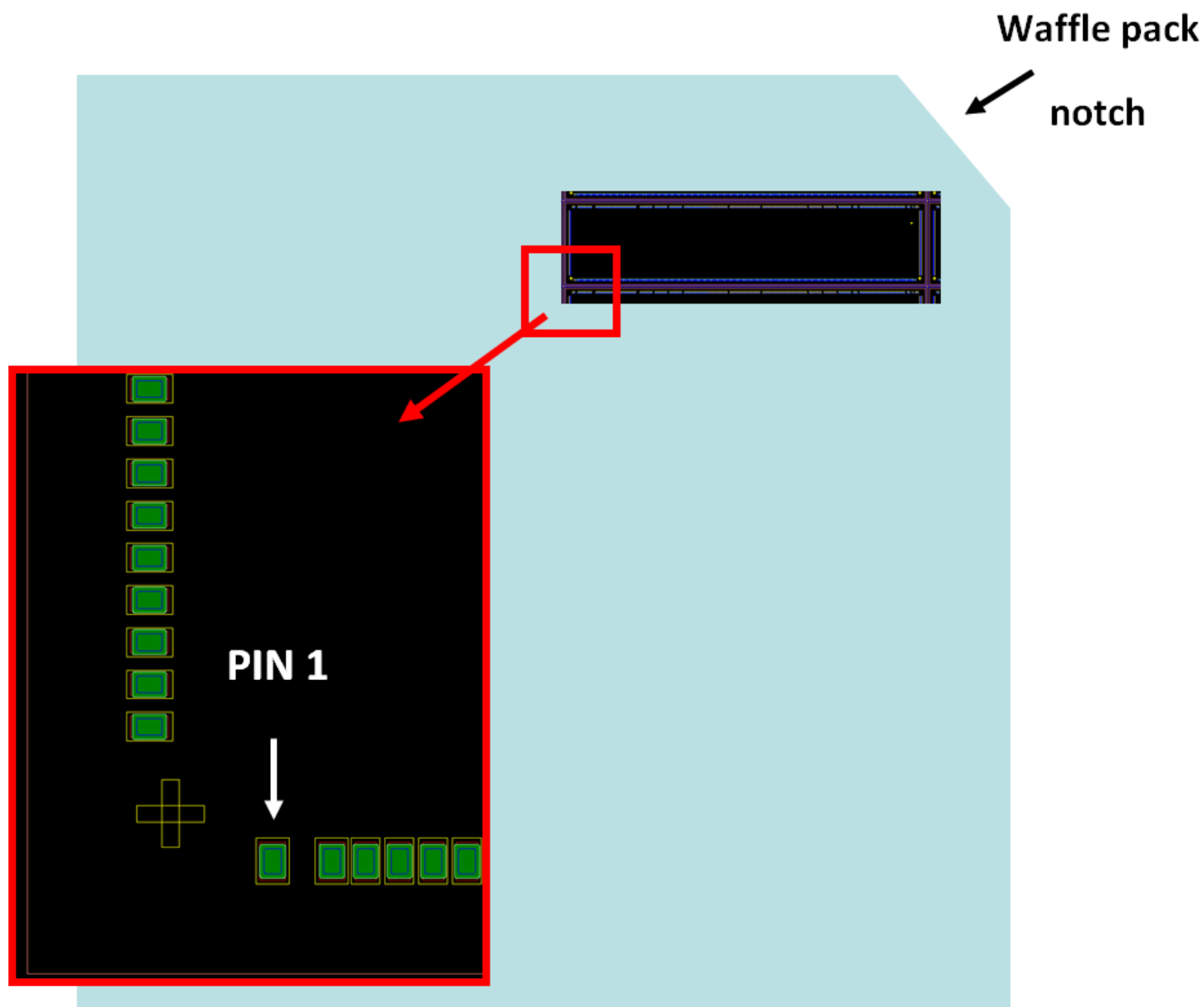
ACTIVE: Product device recommended for new designs.

LIFEBUY: TI has announced that the device will be discontinued, and a lifetime-buy period is in effect.

NRND: Not recommended for new designs. Device is in production to support existing customers, but TI does not recommend using this part in a new design.

PREVIEW: Device has been announced but is not in production. Samples may or may not be available.

OBSOLETE: TI has discontinued the production of the device.

(2) **RoHS:** TI defines "RoHS" to mean semiconductor products that are compliant with the current EU RoHS requirements for all 10 RoHS substances, including the requirement that RoHS substance do not exceed 0.1% by weight in homogeneous materials. Where designed to be soldered at high temperatures, "RoHS" products are suitable for use in specified lead-free processes. TI may reference these types of products as "Pb-Free".

RoHS Exempt: TI defines "RoHS Exempt" to mean products that contain lead but are compliant with EU RoHS pursuant to a specific EU RoHS exemption.

Green: TI defines "Green" to mean the content of Chlorine (Cl) and Bromine (Br) based flame retardants meet JS709B low halogen requirements of <=1000ppm threshold. Antimony trioxide based flame retardants must also meet the <=1000ppm threshold requirement.

(3) MSL, Peak Temp. - The Moisture Sensitivity Level rating according to the JEDEC industry standard classifications, and peak solder temperature.

(4) There may be additional marking, which relates to the logo, the lot trace code information, or the environmental category on the device.

(5) Multiple Device Markings will be inside parentheses. Only one Device Marking contained in parentheses and separated by a "~" will appear on a device. If a line is indented then it is a continuation of the previous line and the two combined represent the entire Device Marking for that device.

(6) Lead finish/Ball material - Orderable Devices may have multiple material finish options. Finish options are separated by a vertical ruled line. Lead finish/Ball material values may wrap to two lines if the finish value exceeds the maximum column width.

Important Information and Disclaimer:The information provided on this page represents TI's knowledge and belief as of the date that it is provided. TI bases its knowledge and belief on information provided by third parties, and makes no representation or warranty as to the accuracy of such information. Efforts are underway to better integrate information from third parties. TI has taken and continues to take reasonable steps to provide representative and accurate information but may not have conducted destructive testing or chemical analysis on incoming materials and chemicals. TI and TI suppliers consider certain information to be proprietary, and thus CAS numbers and other limited information may not be available for release.

In no event shall TI's liability arising out of such information exceed the total purchase price of the TI part(s) at issue in this document sold by TI to Customer on an annual basis.

重要声明和免责声明

TI“按原样”提供技术和可靠性数据（包括数据表）、设计资源（包括参考设计）、应用或其他设计建议、网络工具、安全信息和其他资源，不保证没有瑕疵且不做任何明示或暗示的担保，包括但不限于对适销性、某特定用途方面的适用性或不侵犯任何第三方知识产权的暗示担保。

这些资源可供使用 TI 产品进行设计的熟练开发人员使用。您将自行承担以下全部责任：(1) 针对您的应用选择合适的 TI 产品，(2) 设计、验证并测试您的应用，(3) 确保您的应用满足相应标准以及任何其他功能安全、信息安全、监管或其他要求。

这些资源如有变更，恕不另行通知。TI 授权您仅可将这些资源用于研发本资源所述的 TI 产品的应用。严禁对这些资源进行其他复制或展示。您无权使用任何其他 TI 知识产权或任何第三方知识产权。您应全额赔偿因在这些资源的使用中对 TI 及其代表造成的任何索赔、损害、成本、损失和债务，TI 对此概不负责。

TI 提供的产品受 [TI 的销售条款](#) 或 [ti.com](#) 上其他适用条款/TI 产品随附的其他适用条款的约束。TI 提供这些资源并不会扩展或以其他方式更改 TI 针对 TI 产品发布的适用的担保或担保免责声明。

TI 反对并拒绝您可能提出的任何其他或不同的条款。

邮寄地址：Texas Instruments, Post Office Box 655303, Dallas, Texas 75265
Copyright © 2024，德州仪器 (TI) 公司