

ATL431LI-Q1/ATL432LI-Q1 高带宽、低 I_Q 可编程并联稳压器

1 特性

- 符合汽车类应用要求
- 具有符合 AEC-Q100 标准的下列特性：
 - 器件温度等级 1: -40°C 至 $+125^{\circ}\text{C}$ 的环境工作温度范围
- 25°C 下的基准电压容差
 - 0.5% (B 级)
 - 1% (A 级)
- 最低输出电压典型值: 2.5V
- 可调输出电压: V_{ref} 至 36V
- 工作温度范围: -40°C 至 $+125^{\circ}\text{C}$
- 27mV 最大温漂
- 输出阻抗典型值 0.3Ω
- 灌电流能力
 - $I_{\text{min}} = 0.08\text{mA}$ (最大值)
 - $I_{\text{KA}} = 15\text{mA}$ (最大值)
- 基准输入电流 I_{REF} : 0.4μA (最大值)
- 整个温度范围内的基准输入电流偏差 $I_{\text{I(dev)}}$: 0.3μA (最大值)

2 应用

- 逆变器和电机控制
- 直流/直流转换器
- LED 照明
- 车载充电器 (OBC)
- 信息娱乐系统和仪表组

3 说明

ATL43xLI-Q1 是一款可调节三端并联稳压器，在适用的汽车级、商用级和军用级温度范围内具有额定的热稳定性。可通过两个外部电阻器将输出电压设置为介于 V_{ref} (约为 2.5V) 和 36V 之间的任意值。该器件的输出阻抗典型值为 0.3Ω，其有源输出电路可提供快速导通特性，从而可在板载稳压、可调节电源和开关电源等多种应用中完美地替代齐纳二极管。这款器件是 TL431LI-Q1 和 TL432LI-Q1 的引脚对引脚替代品，且最低工作电流更低，有助于降低系统功耗。ATL432LI-Q1 具有与 ATL431LI-Q1 完全相同的功能和电气规格，但是具有不同的 DBZ 封装引脚排布。

ATL431LI-Q1 具有 A、B 两个等级，初始容差（在 25°C 下）分别为 1% 和 0.5%。ATL43xLI-Q1 的额定工作温度范围为 -40°C 至 $+125^{\circ}\text{C}$ ，其低输出温漂可确保在整个温度范围内保持良好稳定性。

器件信息(1)

器件型号	封装 (引脚)	封装尺寸 (标称值)
ATL43xLI	SOT-23 (3)	2.90mm x 1.30mm

(1) 如需了解所有可用封装，请参阅数据表末尾的可订购产品附录。

简化原理图

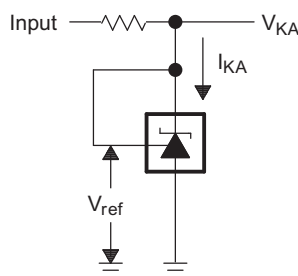

目录

1	特性	1	9.3	Feature Description	13
2	应用	1	9.4	Device Functional Modes	13
3	说明	1	10	Applications and Implementation	14
4	修订历史记录	2	10.1	Application Information	14
5	Device Comparison Table	3	10.2	Typical Applications	14
6	Pin Configuration and Functions	3	10.3	System Examples	24
7	Specifications	4	11	Power Supply Recommendations	27
7.1	Absolute Maximum Ratings	4	12	Layout	27
7.2	ESD Ratings	4	12.1	Layout Guidelines	27
7.3	Recommended Operating Conditions	4	12.2	Layout Example	27
7.4	Thermal Information	4	13	器件和文档支持	28
7.5	Electrical Characteristics	5	13.1	器件支持	28
7.6	Typical Characteristics	6	13.2	文档支持	28
8	Parameter Measurement Information	9	13.3	相关链接	28
8.1	Temperature Coefficient	9	13.4	接收文档更新通知	28
8.2	Dynamic Impedance	10	13.5	支持资源	28
9	Detailed Description	11	13.6	商标	28
9.1	Overview	11	13.7	静电放电警告	28
9.2	Functional Block Diagram	11	13.8	Glossary	29
			14	机械、封装和可订购信息	29

4 修订历史记录

注：之前版本的页码可能与当前版本有所不同。

Changes from Original (May 2019) to Revision A

Page

• 将器件状态从“预告信息”更改为“生产数据”	1
-------------------------------	---

5 Device Comparison Table

DEVICE PINOUT	INITIAL ACCURACY	OPERATING FREE-AIR TEMPERATURE (T _A)
ATL431LI-Q1 ATL432LI-Q1	A: 1% B: 0.5%	Q: -40°C to 125°C

6 Pin Configuration and Functions

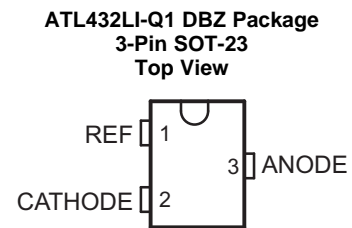
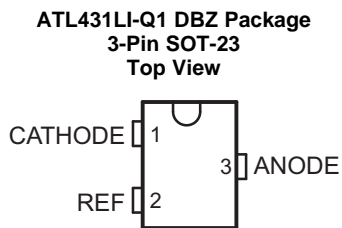

Pin Functions

NAME	PIN		TYPE	DESCRIPTION
	ATL431LI-Q1	ATL432LI-Q1		
	DBZ	DBZ		
ANODE	3	3	O	Common pin, normally connected to ground
CATHODE	1	2	I/O	Shunt Current/Voltage input
REF	2	1	I	Threshold relative to common anode

7 Specifications

7.1 Absolute Maximum Ratings

over operating free-air temperature range (unless otherwise noted)⁽¹⁾

		MIN	MAX	UNIT
V _{KA}	Cathode Voltage ⁽²⁾		37	V
I _{KA}	Continuous Cathode Current Range	-10	18	mA
I _{I(ref)}	Reference Input Current	-5	10	mA
T _J	Operating Junction Temperature Range	-40	150	C
T _{stg}	Storage Temperature Range	-65	150	C

- (1) Stresses beyond those listed under *Absolute Maximum Ratings* may cause permanent damage to the device. These are stress ratings only, which do not imply functional operation of the device at these or any other conditions beyond those indicated under *Recommended Operating Conditions*. Exposure to absolute-maximum-rated conditions for extended periods may affect device reliability.
- (2) All voltage values are with respect to ANODE, unless otherwise noted.

7.2 ESD Ratings

		VALUE	UNIT
V _(ESD)	Electrostatic discharge	Human body model (HBM), per AEC Q100-002 ⁽¹⁾	±4000
		Charged-device model (CDM), per AEC Q100-011	±1000

- (1) AEC Q100-002 indicates that HBM stressing shall be in accordance with the ANSI/ESDA/JEDEC JS-001 specification

7.3 Recommended Operating Conditions

		MIN	MAX	UNIT
V _{KA}	Cathode Voltage	V _{REF}	36	V
I _{KA}	Continuous Cathode Current Range	0.08	15	mA
T _A	Operating Free-Air Temperature ⁽¹⁾	-40	125	C

- (1) Maximum power dissipation is a function of T_{J(max)}, θ_{JA}, and T_A. The maximum allowable power dissipation at any allowable ambient temperature is P_D = (T_{J(max)} - T_A)/θ_{JA}. Operating at the absolute maximum T_J can affect reliability. See the [Semiconductor and IC Package Thermal Metrics Application Report](#) for more information.

7.4 Thermal Information

THERMAL METRIC ⁽¹⁾		ATL43xLI	UNIT
		DBZ	
		3 PINS	
R _{θJA}	Junction-to-ambient thermal resistance	371.7	C/W
R _{θJC(top)}	Junction-to-case (top) thermal resistance	145.9	C/W
R _{θJB}	Junction-to-board thermal resistance	104.7	C/W
ψ _{JT}	Junction-to-top characterization parameter	23.9	C/W
ψ _{JB}	Junction-to-board characterization parameter	102.9	C/W

- (1) For more information about traditional and new thermal metrics, see the [Semiconductor and IC Package Thermal Metrics Application Report](#).

7.5 Electrical Characteristics

over recommended operating conditions, $T_A = 25^\circ\text{C}$ (unless otherwise noted)

PARAMETER		TEST CIRCUIT	TEST CONDITIONS	MIN	TYP	MAX	UNIT	
V_{REF}	Reference Voltage	See Figure 17	$V_{\text{KA}} = V_{\text{ref}}, I_{\text{KA}} = 1 \text{ mA}$	ATL43xLIAx devices	2475	2500	2525	mV
				ATL43xLIBx devices	2487	2500	2512	mV
$V_{\text{I(dev)}}$	Deviation of reference input voltage over full temperature range ⁽¹⁾	See Figure 17	$V_{\text{KA}} = V_{\text{ref}}, I_{\text{KA}} = 1 \text{ mA}$		10	27	mV	
$\frac{\Delta V_{\text{ref}}}{\Delta V_{\text{KA}}}$	Ratio of change in reference voltage to the change in cathode voltage	See Figure 18	$I_{\text{KA}} = 1 \text{ mA}$	$\Delta V_{\text{KA}} = 10 \text{ V} - V_{\text{ref}}$	-1.4	-2.7	mV/V	
				$\Delta V_{\text{KA}} = 36 \text{ V} - 10 \text{ V}$	-1	-2	mV/V	
I_{ref}	Reference Input Current	See Figure 18	$I_{\text{KA}} = 1 \text{ mA}, R1 = 10\text{k}\Omega, R2 = \infty$		0.2	0.4	μA	
$I_{\text{I(dev)}}$	Deviation of reference input current over full temperature range ⁽¹⁾	See Figure 18	$I_{\text{KA}} = 1 \text{ mA}, R1 = 10\text{k}\Omega, R2 = \infty$		0.1	0.3	μA	
I_{min}	Minimum cathode current for regulation	See Figure 17	$V_{\text{KA}} = V_{\text{ref}}$		65	80	μA	
I_{off}	Off-state cathode current	See Figure 19	$V_{\text{KA}} = 36 \text{ V}, V_{\text{ref}} = 0$		0.1	1	μA	
$ Z_{\text{KA}} $	Dynamic Impedance ⁽²⁾	See Figure 17	$V_{\text{KA}} = V_{\text{ref}}, I_{\text{KA}} = 1 \text{ mA to } 15 \text{ mA}$		0.65	0.75	Ω	

- (1) The deviation parameters $V_{\text{I(dev)}}$ and $I_{\text{I(dev)}}$ are defined as the differences between the maximum and minimum values obtained over the rated temperature range. For more details on $V_{\text{I(dev)}}$ and how it relates to the average temperature coefficient, see the [Temperature Coefficient](#) section.
- (2) The dynamic impedance is defined by $|Z_{\text{KA}}| = \Delta V_{\text{KA}} / \Delta I_{\text{KA}}$. For more details on $|Z_{\text{KA}}|$ and how it relates to V_{out} , see the [Temperature Coefficient](#) section.

7.6 Typical Characteristics

Data at high and low temperatures are applicable only within the recommended operating free-air temperature ranges of the various devices.

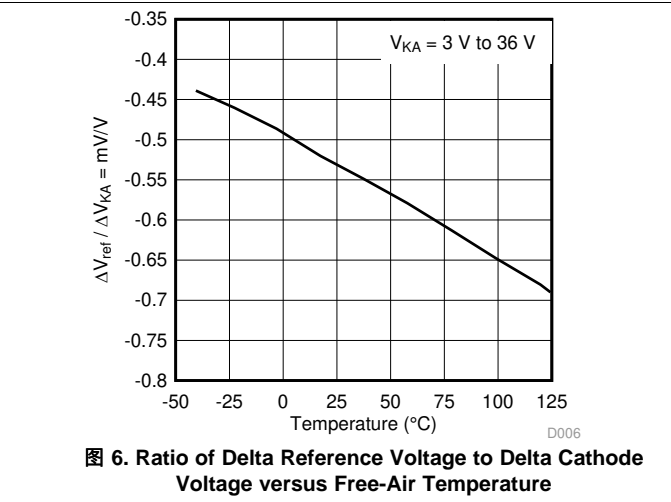
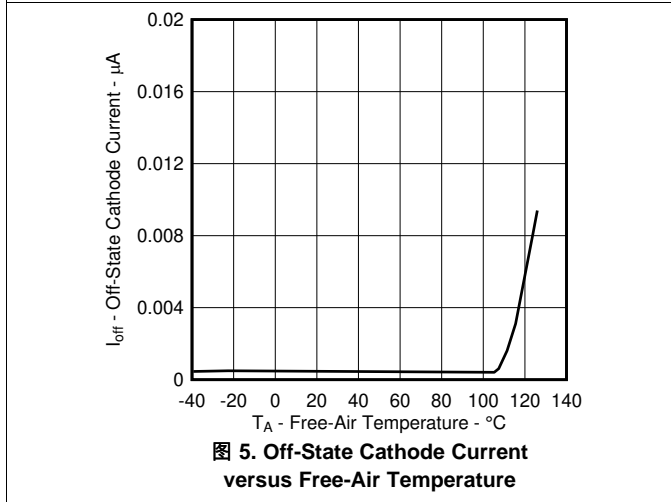
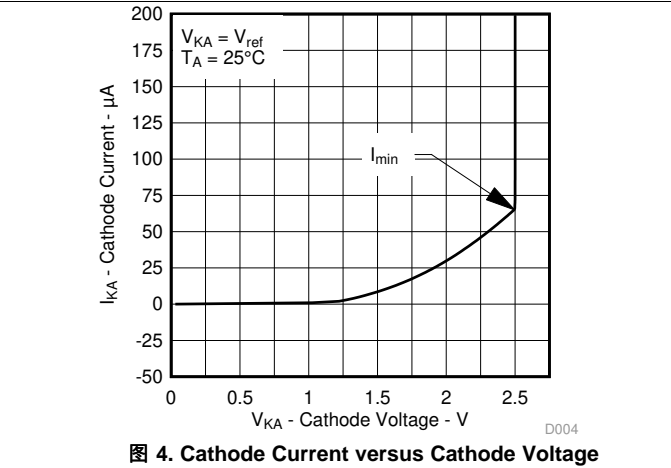
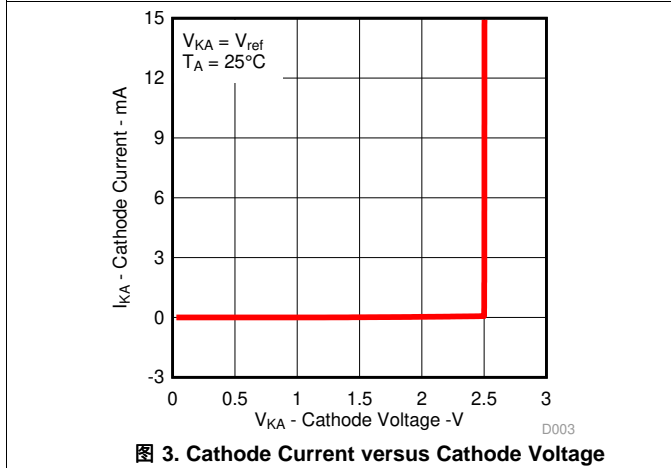
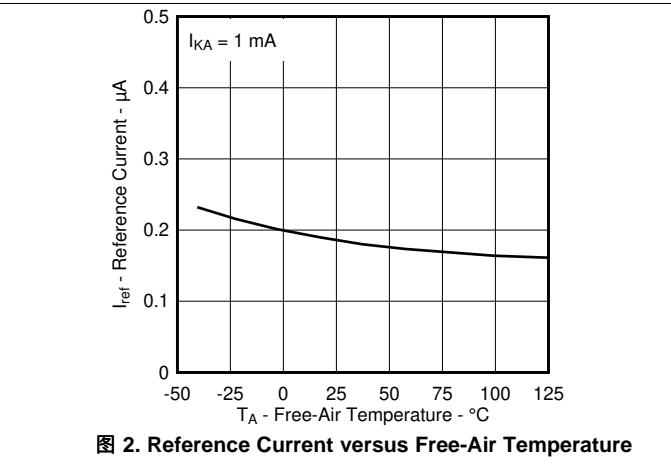
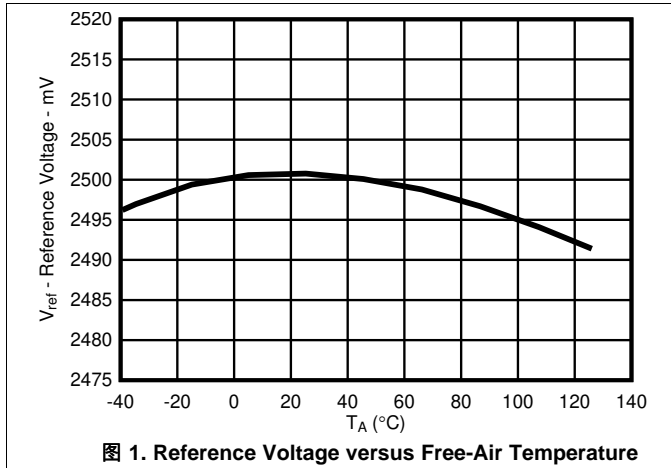

Typical Characteristics (接下页)



图 7. Small-Signal Voltage Amplification versus Frequency



图 8. Test Circuit for Voltage Amplification

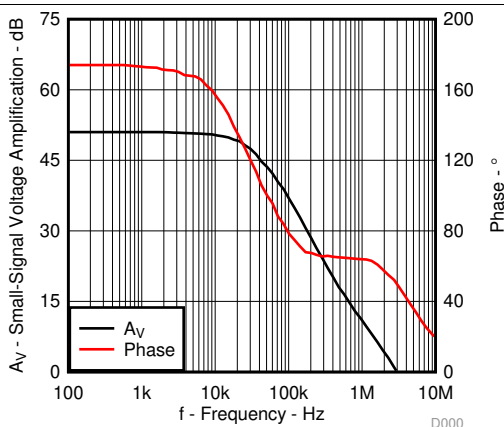

图 9. Reference Impedance versus Frequency

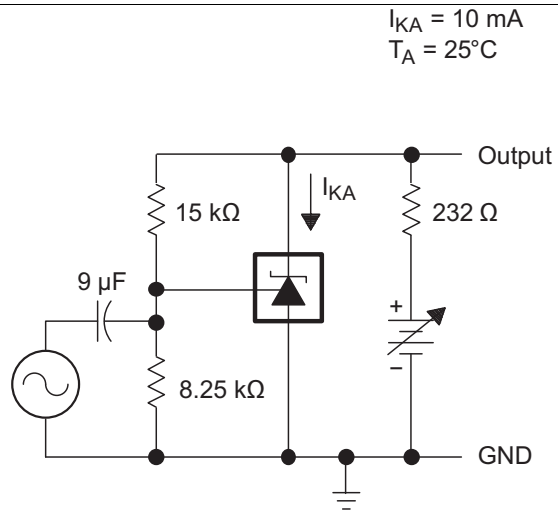

图 10. Test Circuit for Reference Impedance

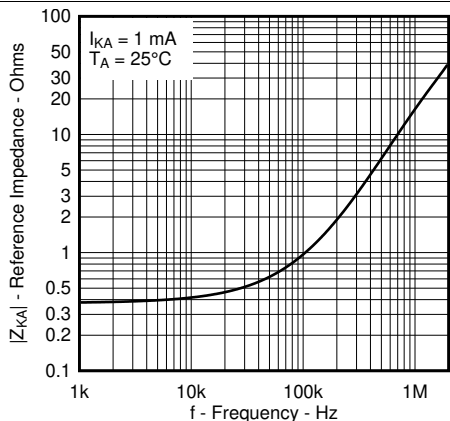

图 11. Pulse Response

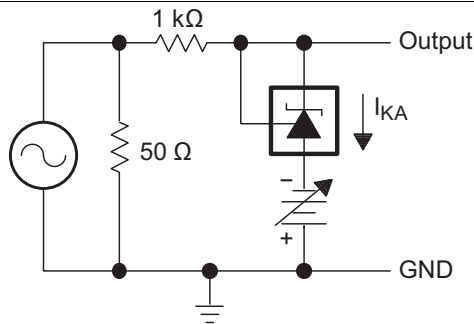

图 12. Test Circuit for Pulse Response

Typical Characteristics (接下页)

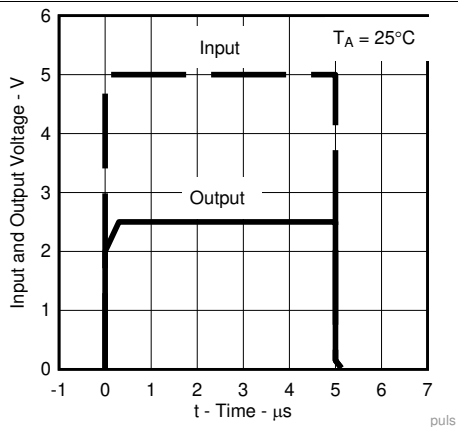

The areas under the curves represent conditions that may cause the device to oscillate. For curves B and C, R2 and V+ are adjusted to establish the initial V_{KA} and I_{KA} conditions, with $C_L = 0$. V_{BATT} and C_L then are adjusted to determine the ranges of stability.

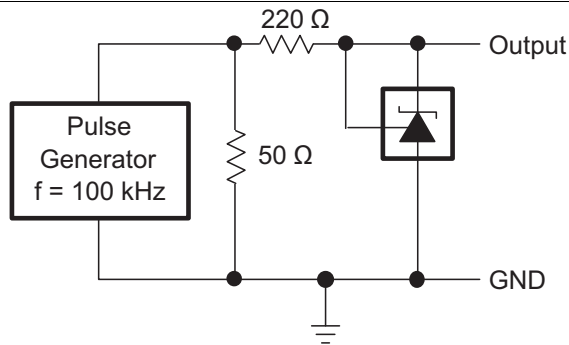
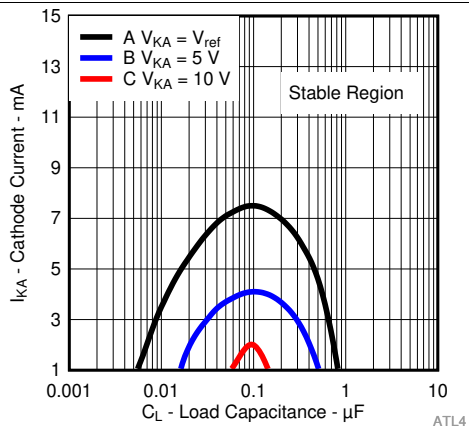
图 13. Stability Boundary Conditions for All ATL431LI-Q1, ATL432LI-Q1 Devices Above 1 mA

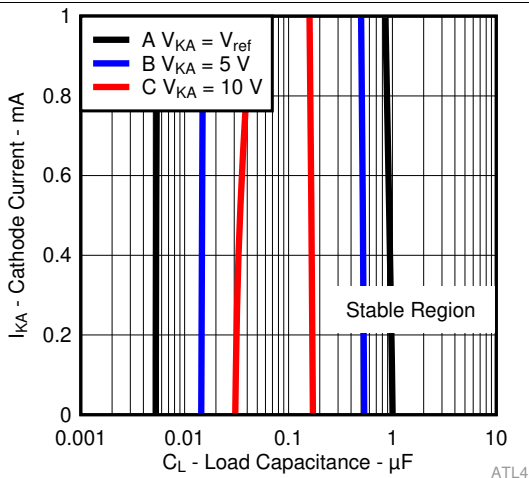

The areas in-between the curves represent conditions that may cause the device to oscillate. For curves B and C, R2 and V+ are adjusted to establish the initial V_{KA} and I_{KA} conditions, with $C_L = 0$. V_{BATT} and C_L then are adjusted to determine the ranges of stability.

图 15. Stability Boundary Conditions for All ATL431LI-Q1, ATL432LI-Q1 Devices Below 1 mA

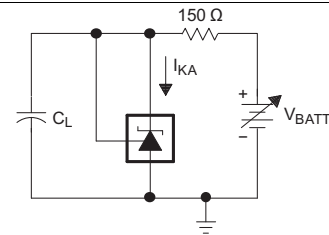

TEST CIRCUIT FOR CURVE A

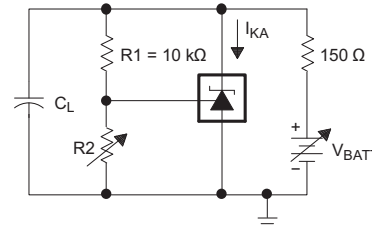

TEST CIRCUIT FOR CURVES B, C, AND D

图 14. Test Circuit for Stability Boundary Conditions

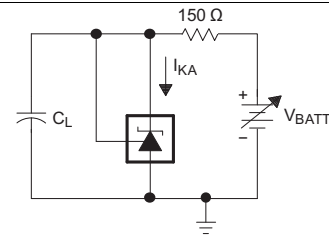

TEST CIRCUIT FOR CURVE A

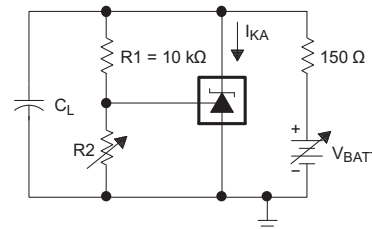

TEST CIRCUIT FOR CURVES B, C, AND D

图 16. Test Circuit for Stability Boundary Conditions

8 Parameter Measurement Information



图 17. Test Circuit for $V_{KA} = V_{ref}$



图 18. Test Circuit for $V_{KA} > V_{ref}$

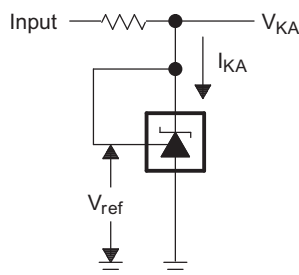

图 19. Test Circuit for I_{off}

8.1 Temperature Coefficient

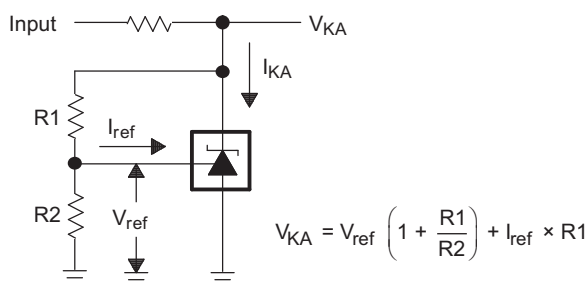
The deviation of the reference voltage, V_{ref} , over the full temperature range is known as $V_{I(dev)}$. The parameter of $V_{I(dev)}$ can be used to find the temperature coefficient of the device. The average full-range temperature coefficient of the reference input voltage, $\alpha_{V_{ref}}$, is defined as:

$$\left| \alpha_{V_{ref}} \right| \left(\frac{\text{ppm}}{^{\circ}\text{C}} \right) = \frac{\left(\frac{V_{I(dev)}}{V_{ref} \text{ at } 25^{\circ}\text{C}} \right) \times 10^6}{\Delta T_A}$$

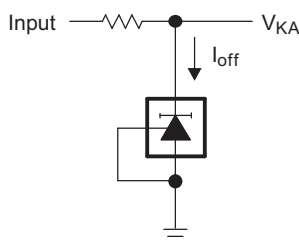
where:

ΔT_A is the rated operating temperature range of the device.

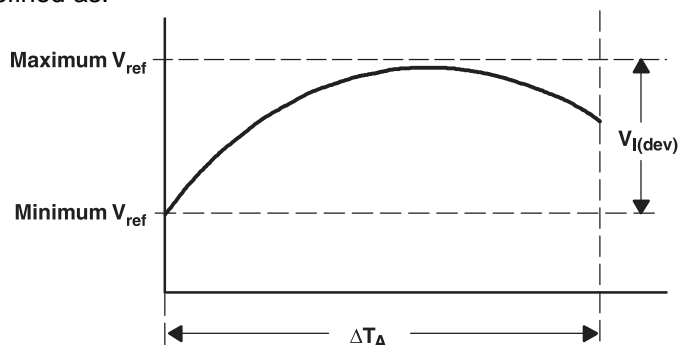

$\alpha_{V_{ref}}$ is positive or negative, depending on whether minimum V_{ref} or maximum V_{ref} , respectively, occurs at the lower temperature. The full-range temperature coefficient is an average and, therefore, any subsection of the rated operating temperature range can yield a value that is greater or less than the average. For more details on temperature coefficient, refer to the [Voltage Reference Selection Basics White Paper](#).

8.2 Dynamic Impedance

The dynamic impedance is defined as: $|Z_{KA}| = \frac{\Delta V_{KA}}{\Delta I_{KA}}$. When the device is operating with two external resistors (see [图 18](#)), the total dynamic impedance of the circuit is given by: $|z'| = \frac{\Delta V}{\Delta I}$, which is approximately equal to $|Z_{KA}| \left(1 + \frac{R1}{R2}\right)$.

The V_{KA} of the ATL431LI-Q1 can be affected by the dynamic impedance. The ATL431LI-Q1 test current I_{test} for V_{KA} is specified in the [Electrical Characteristics](#). Any deviation from I_{test} can cause deviation on the output V_{KA} . [图 20](#) shows the effect of the dynamic impedance on the V_{KA} .



图 20. Dynamic Impedance

9 Detailed Description

9.1 Overview

This standard device has proven ubiquity and versatility across a wide range of applications, ranging from power to signal path. This is due to its key components containing an accurate voltage reference and op amp, which are very fundamental analog building blocks. The ATL431LI-Q1 is used in conjunction with the key components to behave as the following:

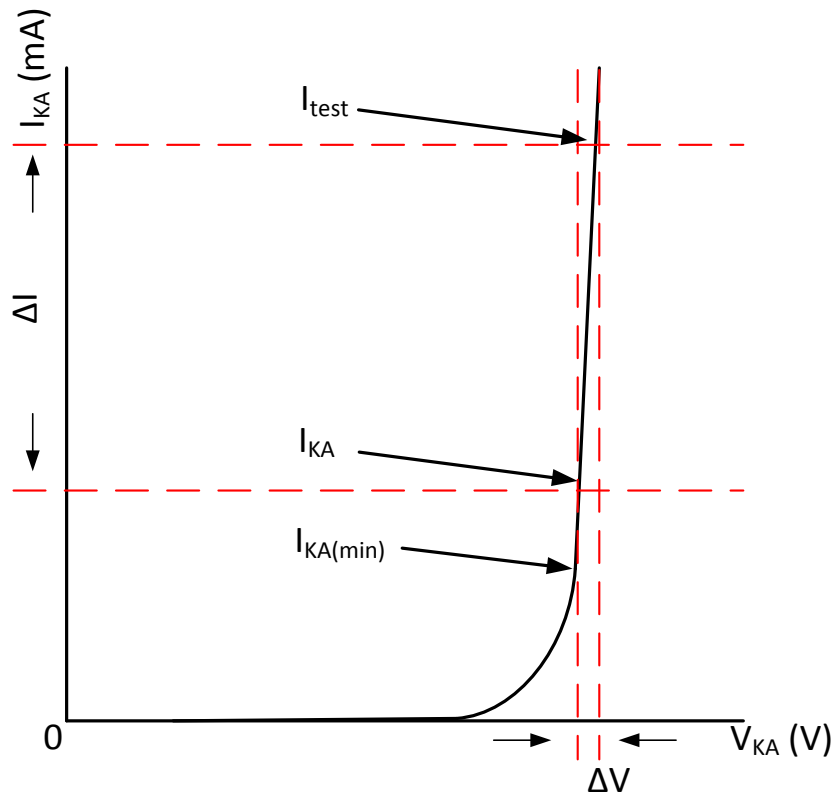
- Single voltage reference
- Error amplifier
- Voltage clamp
- Comparator with integrated reference

ATL431LI-Q1 can be operated and adjusted to cathode voltages from 2.5 V to 36 V, making this part optimal for a wide range of end equipments in industrial, auto, telecom, and computing. For this device to behave as a shunt regulator or error amplifier, $>80 \mu\text{A}$ (I_{min} (maximum)) must be supplied in to the cathode pin. Under this condition, feedback can be applied from the Cathode and Ref pins to create a replica of the internal reference voltage.

Various reference voltage options can be purchased with initial tolerances (at 25°C) of 0.5% and 1%. These reference options are denoted by B (0.5%) and A (1.0%) after the ATL431LI-Q1 or ATL432LI-Q1. ATL431LI-Q1 and ATL432LI-Q1 are both functionally the same, but have different pinout options. The ATL43xLI-Q1 devices are characterized for operation from -40°C to $+125^{\circ}\text{C}$.

9.2 Functional Block Diagram



图 21. Equivalent Schematic

Functional Block Diagram (接下页)

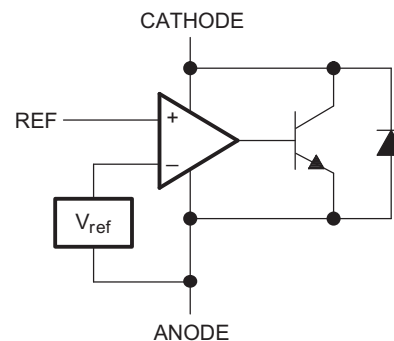

图 22. Detailed Schematic

9.3 Feature Description

The ATL431LI-Q1 consists of an internal reference and amplifier that outputs a sink current based on the difference between the reference pin and the virtual internal pin. The sink current is produced by the internal Darlington pair, shown in [Figure 21](#). A Darlington pair is used for this device to be able to sink a maximum current of 15 mA.

When operated with enough voltage headroom (≥ 2.5 V) and cathode current (I_{KA}), the ATL431LI-Q1 forces the reference pin to 2.5 V. However, the reference pin cannot be left floating, as it needs $I_{REF} \geq 0.4$ μ A (see the [Specifications](#)). This is because the reference pin is driven into an NPN, which needs base current to operate properly.

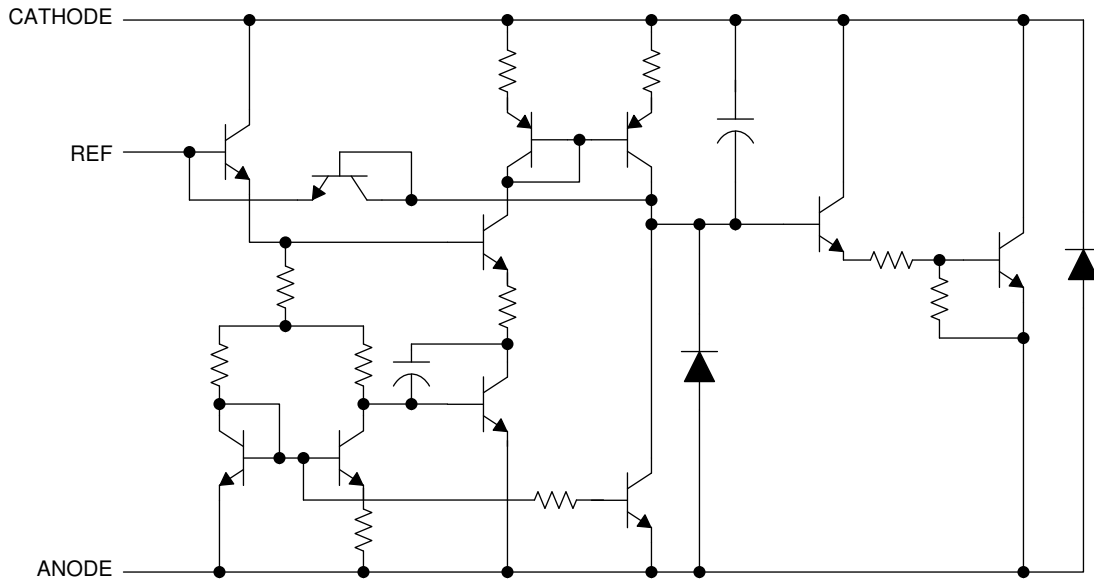
When feedback is applied from the Cathode and Reference pins, the ATL431LI-Q1 behaves as a Zener diode, regulating to a constant voltage dependent on current being supplied into the cathode. This is due to the internal amplifier and reference entering the proper operating regions. The same amount of current needed in the above feedback situation must be applied to this device in open loop, servo, or error amplifying implementations for it to be in the proper linear region giving ATL431LI-Q1 enough gain.

Unlike many linear regulators, ATL431LI-Q1 is internally compensated to be stable without an output capacitor between the cathode and anode. However, if it is desired to use an output capacitor [Figure 13](#) can be used as a guide to assist in choosing the correct capacitor to maintain stability.

9.4 Device Functional Modes

9.4.1 Open Loop (Comparator)

When the cathode/output voltage or current of ATL431LI-Q1 is not being fed back to the reference/input pin in any form, this device is operating in open loop. With proper cathode current (I_{KA}) applied to this device, the ATL431LI-Q1 has the characteristics shown in [Figure 21](#). With such high gain in this configuration, the ATL431LI-Q1 is typically used as a comparator. With the reference integrated makes ATL431LI-Q1 the preferred choice when users are trying to monitor a certain level of a single signal.

9.4.2 Closed Loop

When the cathode/output voltage or current of the ATL431LI-Q1 is being fed back to the reference/input pin in any form, this device is operating in closed loop. The majority of applications involving ATL431LI-Q1 use it in this manner to regulate a fixed voltage or current. The feedback enables this device to behave as an error amplifier, computing a portion of the output voltage and adjusting it to maintain the desired regulation. This is done by relating the output voltage back to the reference pin in a manner to make it equal to the internal reference voltage, which can be accomplished via resistive or direct feedback.

10 Applications and Implementation

注

Information in the following applications sections is not part of the TI component specification, and TI does not warrant its accuracy or completeness. TI's customers are responsible for determining suitability of components for their purposes. Customers should validate and test their design implementation to confirm system functionality.

10.1 Application Information

As this device has many applications and setups, there are many situations that this data sheet cannot characterize in detail. The linked application note will help the designer make the best choices when using this part.

[Setting the Shunt Voltage on an Adjustable Shunt Regulator Application Note](#) assists with setting the shunt voltage to achieve optimum accuracy for this device.

10.2 Typical Applications

10.2.1 Comparator With Integrated Reference



图 23. Comparator Application Schematic

Typical Applications (接下页)

10.2.2 Design Requirements

For this design example, use the parameters listed in 表 1 as the input parameters.

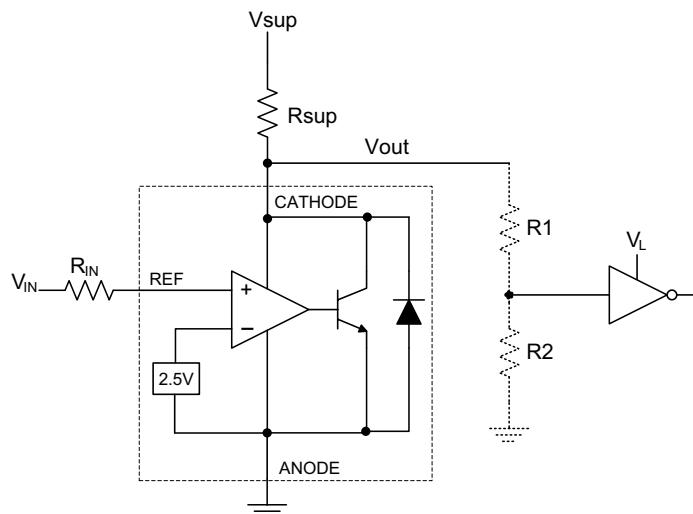
表 1. Design Parameters

DESIGN PARAMETER	EXAMPLE VALUE
Input Voltage Range	0 V to 5 V
Input Resistance	10 k Ω
Supply Voltage	24 V
Cathode Current (I_K)	5 mA
Output Voltage Level	$\sim 2\text{ V} - V_{SUP}$
Logic Input Thresholds V_{IH}/V_{IL}	V_L

10.2.3 Detailed Design Procedure

When using the ATL431LI-Q1 as a comparator with reference, determine the following:

- Input voltage range
- Reference voltage accuracy
- Output logic input high and low level thresholds
- Current source resistance

10.2.3.1 Basic Operation

In the configuration shown in 图 23, the ATL431LI-Q1 behaves as a comparator, comparing the V_{REF} pin voltage to the internal virtual reference voltage. When provided a proper cathode current (I_K), ATL431LI-Q1 has enough open-loop gain to provide a quick response. This can be seen in 图 24 where the $R_{SUP} = 10\text{ k}\Omega$ ($I_{KA} = 500\text{ }\mu\text{A}$) situation responds much slower than $R_{SUP} = 1\text{ k}\Omega$ ($I_{KA} = 5\text{ mA}$). With the ATL431LI-Q1 max operating current (I_{MIN}) being 1 mA, operation below that can result in low gain, leading to a slow response.

10.2.3.1.1 Overdrive

Slow or inaccurate responses can also occur when the reference pin is not provided enough overdrive voltage. This is the amount of voltage that is higher than the internal virtual reference. The internal virtual reference voltage is within the range of $2.5\text{ V} \pm(0.5\% \text{ or } 1.0\%)$ depending on which version is being used. The more overdrive voltage provided, the faster the ATL431LI-Q1 will respond.

For applications where ATL431LI-Q1 is being used as a comparator, it is best to set the trip point to greater than the positive expected error (that is +1.0% for the A version). For fast response, setting the trip point to >10% of the internal V_{REF} suffices.

For minimal voltage drop or difference from V_{in} to the ref pin, TI recommends to use an input resistor <10 k Ω to provide I_{ref} .

10.2.3.2 Output Voltage and Logic Input Level

For ATL431LI-Q1 to properly be used as a comparator, the logic output must be readable by the receiving logic device. This is accomplished by knowing the input high and low level threshold voltage levels, typically denoted by V_{IH} and V_{IL} .

As seen in [图 24](#), the output low level voltage of the ATL431LI-Q1 in open-loop/comparator mode is approximately 2 V, which is typically sufficient for 5 V supplied logic. However, this does not work for 3.3 V and 1.8 V supplied logic. To accommodate this, a resistive divider can be tied to the output to attenuate the output voltage to a voltage legible to the receiving low voltage logic device.

The output high voltage of the ATL431 is equal to V_{SUP} due to ATL431LI-Q1 being open-collector. If V_{SUP} is much higher than the maximum input voltage tolerance of the receiving logic, the output must be attenuated to accommodate the reliability of the outgoing logic.

When using a resistive divider on the output, make sure the sum of the resistive divider (R_1 and R_2 in [图 23](#)) is much greater than R_{SUP} to not interfere with the ability of the ATL431LI-Q1 to pull close to V_{SUP} when turning off.

10.2.3.2.1 Input Resistance

The ATL431LI-Q1 requires an input resistance in this application to source the reference current (I_{REF}) needed from this device to be in the proper operating regions while turning on. The actual voltage seen at the ref pin is $V_{REF} = V_{IN} - I_{REF} \times R_{IN}$ because I_{REF} can be as high as 4 μA . TI recommends to use a resistance small enough that mitigates the error that I_{REF} creates from V_{IN} .

10.2.4 Application Curves



图 24. Output Response With Various Cathode Currents

10.2.5 Precision LED Lighting Current Sink Regulator

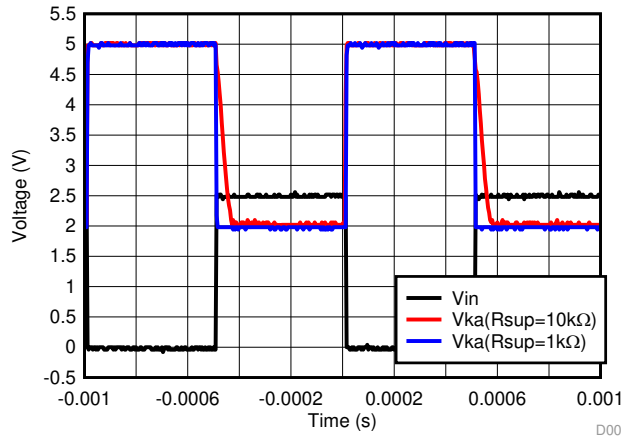

图 25. LED Lighting Current Sink Regulator

10.2.5.1 Design Requirements

For this design example, use the parameters listed in 表 1 as the input parameters.

表 2. Design Parameters

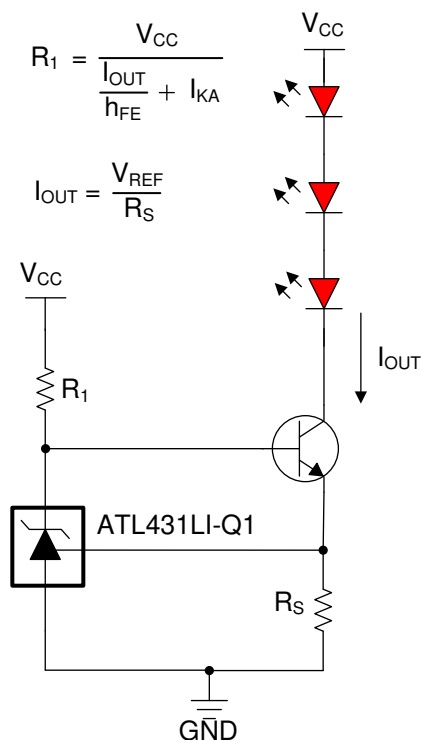
DESIGN PARAMETER	EXAMPLE VALUE
Supply Voltage ($V_{(BATT)}$)	5 V
Sink Current (I_O)	100 mA
Cathode Current (I_k)	5 mA

10.2.5.2 Detailed Design Procedure

When using the ATL43xLI-Q1 as a constant current sink, determine the following:

- Output current range
- Output current accuracy
- Power consumption for the ATL43xLI-Q1

10.2.5.2.1 Basic Operation

In the configuration shown, the ATL43xLI-Q1 acts as a control component within a feedback loop of the constant current sink. Working with an external passing component such as a BJT, the ATL43xLI-Q1 provides precision current sink with accuracy set by itself and the sense resistor R_S . The LEDs are lit based on the desired current sink and regulated for accurate brightness and color.

10.2.5.2.1.1 Output Current Range and Accuracy

The output current range of the circuit is determined by the equation shown in the configuration. Keep in mind that the V_{REF} equals to 2.500 V. When choosing the sense resistor R_S , it needs to generate 2.500 V for the TL43xLI-Q1 when I_O reaches the target current. If the overhead voltage of 2.500 V is not acceptable, consider lower voltage reference devices such as the TLV43x-Q1 or TLVH43x-Q1.

The output current accuracy is determined by both the accuracy of the ATL43xLI-Q1 chosen, as well as the accuracy of the sense resistor R_S . The internal virtual reference voltage of ATL43xLI-Q1 is within the range of $2.500\text{ V} \pm(0.5\% \text{ or } 1.0\%)$, depending on which version is being used. Another consideration for the output current accuracy is the temperature coefficient of the ATL43xLI-Q1 and R_S . Refer to the for the specification of these parameters.

10.2.5.2.2 Power Consumption

For the ATL43xLI-Q1 to properly be used as a control component in this circuit, the minimum operating current needs to be reached. This is accomplished by setting the external biasing resistor in series with the ATL43xLI-Q1.

To achieve lower power consumption, the ATL43xLI-Q1 is used due to its $65\ \mu\text{A}$ typical minimum cathode current, I_{min} .

10.2.6 Shunt Regulator/Reference



图 26. Shunt Regulator Schematic

10.2.6.1 Design Requirements

For this design example, use the parameters listed in 表 1 as the input parameters.

表 3. Design Parameters

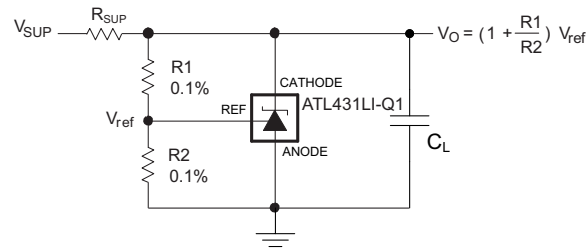
DESIGN PARAMETER	EXAMPLE VALUE
Reference Initial Accuracy	1.0%
Supply Voltage	24 V
Cathode Current (I _k)	5 mA
Output Voltage Level	2.5 V–36 V
Load Capacitance	2 μF
Feedback Resistor Values and Accuracy (R1 and R2)	10 kΩ

10.2.6.2 Detailed Design Procedure

When using ATL431LI-Q1 as a shunt regulator, determine the following:

- Input voltage range
- Temperature range
- Total accuracy
- Cathode current
- Reference initial accuracy
- Output capacitance

10.2.6.2.1 Programming Output/Cathode Voltage

To program the cathode voltage to a regulated voltage, a resistive bridge must be shunted between the cathode and anode pins with the mid point tied to the reference pin. This can be seen in 图 26 with R1 and R2 being the resistive bridge. The cathode/output voltage in the shunt regulator configuration can be approximated by the equation shown in 图 26. The cathode voltage can be more accurate, which can be determined by taking in to account the cathode current:

$$V_o = (1 + R1/R2) \times V_{REF} - I_{REF} \times R1 \quad (1)$$

For this equation to be valid, the ATL431LI-Q1 must be fully biased so that it has enough open loop gain to mitigate any gain error. This can be done by meeting the I_{min} spec denoted in the [Specifications](#).

10.2.6.2.2 Total Accuracy

When programming the output above unity gain ($V_{KA} = V_{REF}$), the ATL431LI-Q1 is susceptible to other errors that can effect the overall accuracy beyond V_{REF} . These errors include:

- R1 and R2 accuracies
- $V_{I(dev)}$: Change in reference voltage over temperature
- $\Delta V_{REF} / \Delta V_{KA}$: Change in reference voltage to the change in cathode voltage
- $|z_{KA}|$: Dynamic impedance, causing a change in cathode voltage with cathode current

Worst case cathode voltage can be determined taking all of the variables in to account. The [Setting the Shunt Voltage on an Adjustable Shunt Regulator Application Note](#) assists designers in setting the shunt voltage to achieve optimum accuracy for this device.

10.2.6.2.3 Stability

Though ATL431LI-Q1 is stable with no capacitive load, the device that receives the output voltage of the shunt regulator can present a capacitive load that is within the ATL431LI-Q1 region of stability, shown in [Figure 13](#). Also, designers can use capacitive loads to improve the transient response or for power supply decoupling. When using additional capacitance between Cathode and Anode, see [Figure 13](#). Also, [Understanding Stability Boundary Conditions Charts in TL431, TL432 Data Sheet Application Note](#) provides a deeper understanding of the stability characteristics of this device and aids the user in making the right choices when choosing a load capacitor.

10.2.6.2.4 Start-Up Time

As shown in [Figure 27](#), the ATL431LI-Q1 has a fast response up to approximately 2 V and then slowly charges to its programmed value. This is due to the compensation capacitance (shown in [Figure 13](#)) the ATL43xLI-Q1 has to meet its stability criteria. Despite the secondary delay, ATL43xLI-Q1 still has a fast response suitable for many clamp applications.

10.2.6.3 Application Curves



图 27. ATL43xLI-Q1 Start-Up Response

10.2.7 Isolated Flyback with Optocoupler

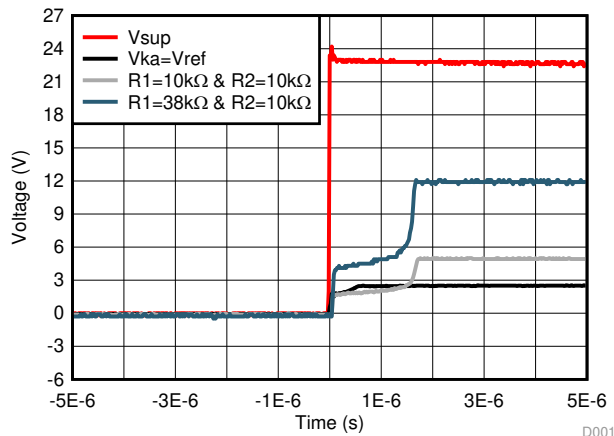

图 28. Isolated Flyback with Optocoupler

10.2.7.1 Design Requirements

The ATL431LI-Q1 is used in the feedback network on the secondary side for a isolated flyback with optocoupler design. 图 28 shows the simplified flyback converter that used the ATL431LI-Q1. For this design example, use the parameters in 表 4 as the input parameters.

表 4. Design Parameters

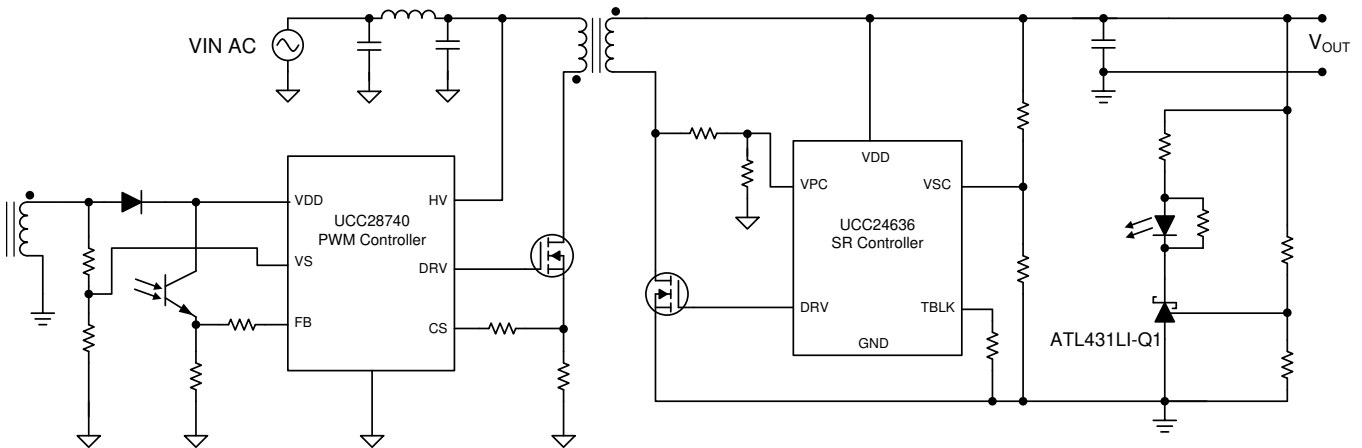
DESIGN PARAMETER	EXAMPLE VALUE
Voltage Output	20 V
Feedback Network Quiescent Current (I_q)	<40 mW

10.2.7.1.1 Detailed Design Procedure

In this example, a simplified design procedure will be discussed. The compensation network for the feedback network is beyond the scope of this section. Details on compensation network can be found in [Compensation Design with TL431 for UCC28600 Application Report](#).

The goal of this design is to design a low standby current feedback network to meet the Europe CoC Tier 2 and United States DoE Level VI requirements. To meet the design requirements, the system standby power needs to be below 75 mW. To meet this, the feedback network needs to consume less than 40 mW to allow margin for the power losses on the primary side controller and passive components. This can pose a challenge in systems greater than 10 V.



图 29. Feedback Quiescent Current

10.2.7.1.1.1 ATL431LI-Q1 Biasing

图 29 shows the simplified version of the feedback network. The standby I_q of the system is dependent on two paths: the ATL431LI-Q1 biasing path and the resistor feedback path. With the given design requirements, the total current through the feedback network cannot exceed 2 mA.

The design goal is to take full advantage of the I_{min} to set the I_{KA} of the ATL431LI-Q1. The benefit of the ATL431LI-Q1 is its low I_{min} of 80 μA which allows the I_{KA} to be lower at a full load condition compared to typical TL431LI-Q1 devices. This helps lower the I_{KA} at the no-load condition which is higher than the full load condition due to the dynamic changes in the I_{KA} as the system load varies. The I_{KA} at no-load, I_{OPTNL} , is dependent the value of R_s which is the biasing resistor. R_s is very application-specific and is dependent on variables such as the CTR of the optocoupler, voltage, and current at no-load. This can be seen in 公式 2. It is possible to lower I_{OPTNL} to a value of 1.5 mA for a power loss of 30 mW by using an optocoupler with a high CTR.

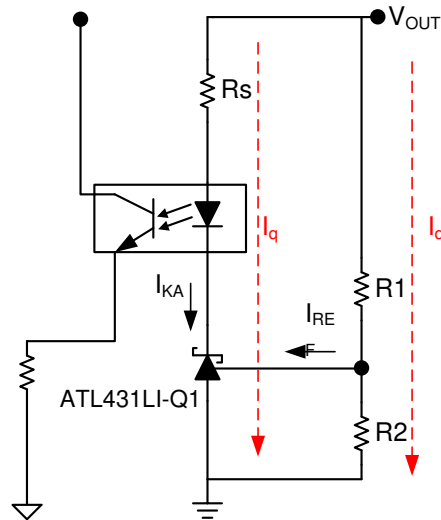
$$R_s \approx (V_{OUT} - V_{OPTNL} - 2V) / I_{OPTNL}$$

$$V_{OPTNL} = \text{Optocoupler Voltage at No - Load Conditions}$$

$$I_{OPTNL} = \text{Optocoupler Current at No - Load Conditions}$$

(2)

10.2.7.1.1.2 Resistor Feedback Network

The feedback resistors set the output voltage of the secondary side and consume the same I_q at a fixed voltage. The design goal for the feedback resistor path is to minimize the resistor error while maintaining a low I_q . For this system example, the feedback network path in this design consumes 0.5 mA to allow enough current for ATL431LI-Q1 biasing. The resistors, R_1 and R_2 , are sized based on a 0.5 mA budget for I_q and I_{ref} . By using the resistor values from 公式 3 and 公式 4, the total power consumption is 10 mW. This can be further decreased by using larger resistors.

$$R_1 = (V_{OUT} - V_{REF}) / I_{FB}$$

$$R_1 = (20V - 2.5V) / 0.5mA$$

$$R_1 = 35k\Omega$$

(3)

$$R_2 = V_{REF} / (I_{FB} - I_{REF})$$

$$R_2 = 2.5V / (0.5mA - 0.4\mu A)$$

$$R_2 = 5.004k\Omega$$

(4)

10.2.8 Adjustable Reference for Tracking LDO

10.2.8.1 Design Requirements

The ATL431LI-Q1 is used as a reference voltage to help regulate a supply voltage off an LDO. By adjusting the cathode voltage, the output voltage of the LDO can vary. The TPS7B4250-Q1 is a voltage-tracking LDO with an adjustable pin which needs a precise reference voltage to change the regulate output voltage.

表 5. Design Parameters

DESIGN PARAMETER	EXAMPLE VALUE
Input Voltage	4 V to 40 V
ADJ Reference Voltage	2.500 V–18 V
Output Voltage	2.500 V–18 V
Output Current Rating	50 mA
Output Capacitor Range	1 μ F to 50 μ F
Output Capacitor ESR Range	1 m Ω to 20 Ω

10.2.8.2 Detailed Design Procedure

The goal of this design is to create a precision and stable output stage using an LDO that requires an external voltage reference such as the TPS7B4250-Q1. To begin the design process, the input and desired output voltage range is required. The ATL431LI-Q1 can be adjusted between 2.5 V and 36 V so it covers most of the output voltage rating of TPS7B4250-Q1. For reference voltage under 2.5 V, the TLV431-Q1 voltage reference can be used. The input and output capacitor must also be taken into consideration for decoupling and stability.



图 30. Feedback Quiescent Current

10.2.8.2.1 External Capacitors

An input capacitor, C_I, is recommended to buffer line influences. Connect the capacitors close to the IC pins.

The output capacitor for the TPS7B4250-Q1 device is required for stability. Without the output capacitor, the regulator oscillates. The actual size and type of the output capacitor can vary based on the application load and temperature range. The effective series resistance (ESR) of the capacitor is also a factor in the IC stability. The worst case is determined at the minimum ambient temperature and maximum load expected. To ensure stability of TPS7B4250-Q1 device, the device requires an output capacitor between 1 μ F and 50 μ F with an ESR range between 0.001 Ω and 20 Ω that can cover most types of capacitor ESR variation under the recommend operating conditions. As a result, the output capacitor selection is flexible.

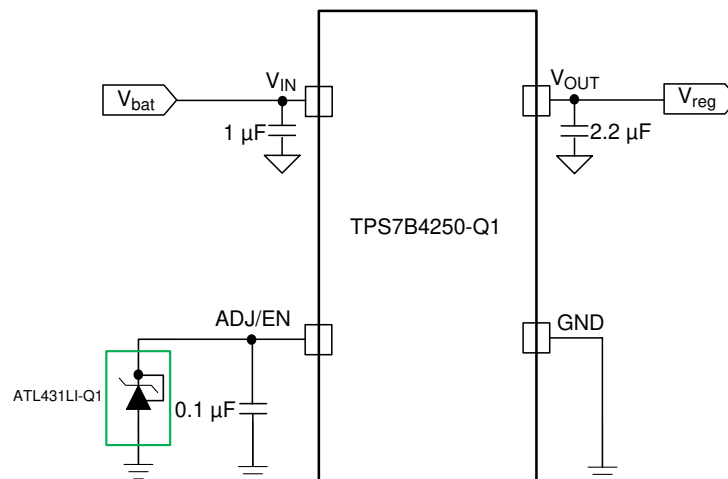
The capacitor must also be rated at all ambient temperature expected in the system. To maintain regulator stability down to -40°C , use a capacitor rated at that temperature.

10.3 System Examples

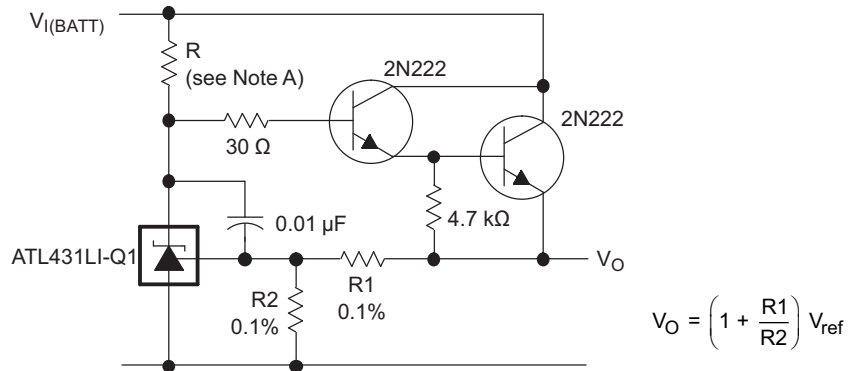

R should provide cathode current $\geq 80 \mu\text{A}$ to the ATL431LI-Q1 at minimum $V_{I(BATT)}$.

图 31. Precision High-Current Series Regulator



图 32. Output Control of a Three-Terminal Fixed Regulator



图 33. High-Current Shunt Regulator

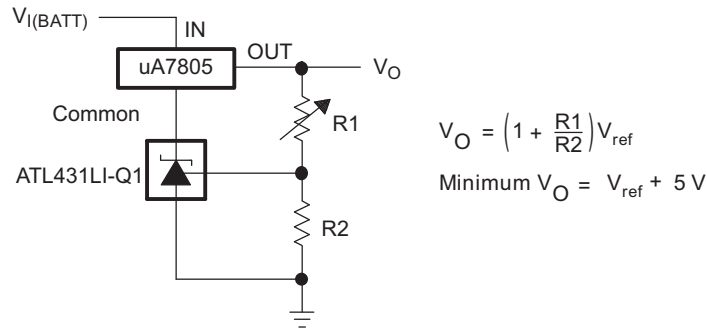

Refer to the stability boundary conditions in 图 13 to determine allowable values for C.

图 34. Crowbar Circuit

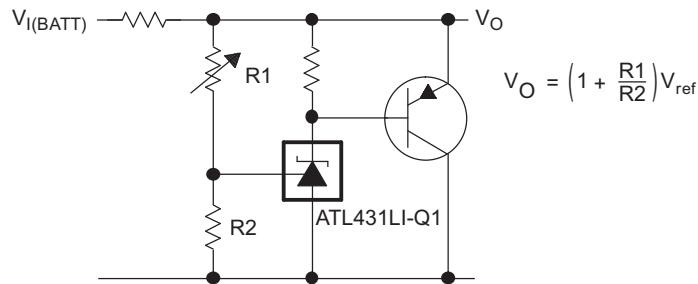
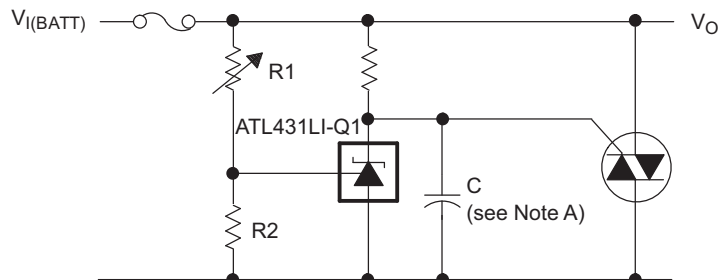
System Examples (接下页)



图 35. Precision 5-V, 1.5-A Regulator



R_b should provide cathode current $\geq 80 \mu\text{A}$ to the ATL431LI-Q1.

图 36. Efficient 5-V Low-Dropout (LDO) Regulator Configuration

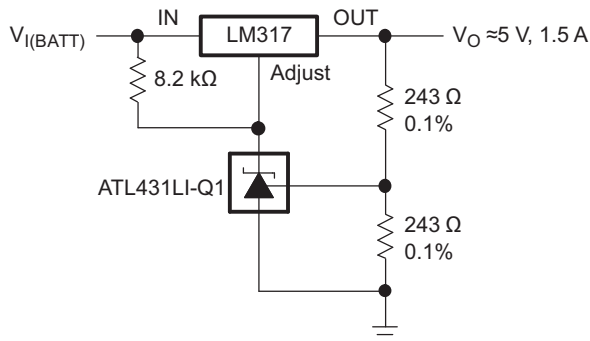
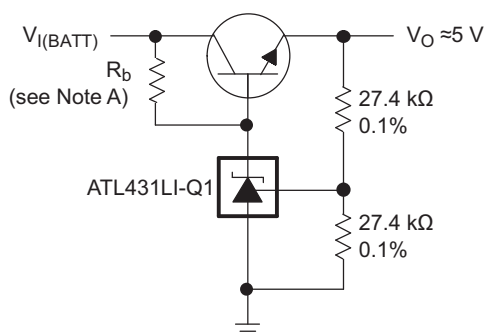

图 37. PWM Converter With Reference

System Examples (接下页)

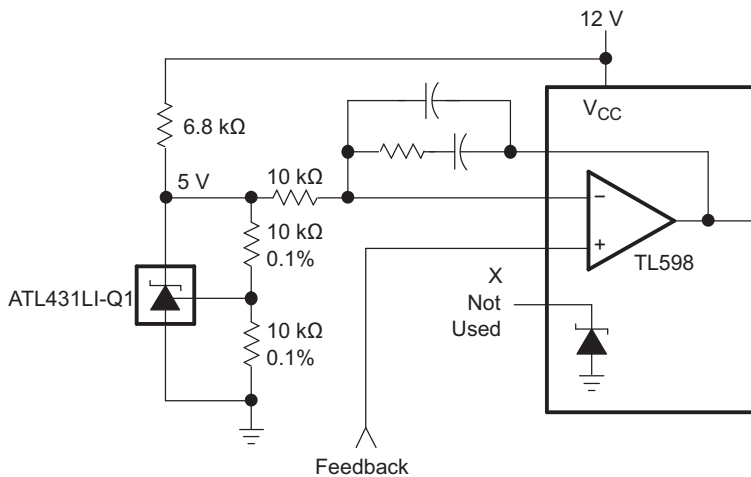
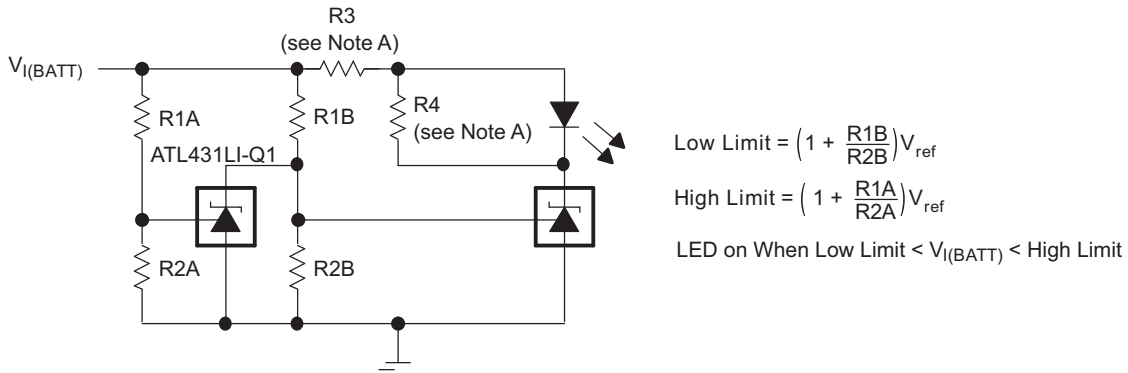

Select R3 and R4 to provide the desired LED intensity and cathode current $\geq 80 \mu A$ to the ATL431LI-Q1 at the available $V_{I(BATT)}$.

图 38. Voltage Monitor



图 39. Delay Timer



图 40. Precision Current Limiter

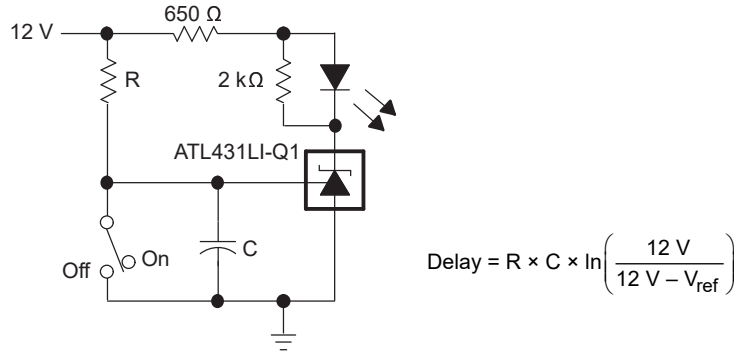

图 41. Precision Constant-Current Sink

11 Power Supply Recommendations

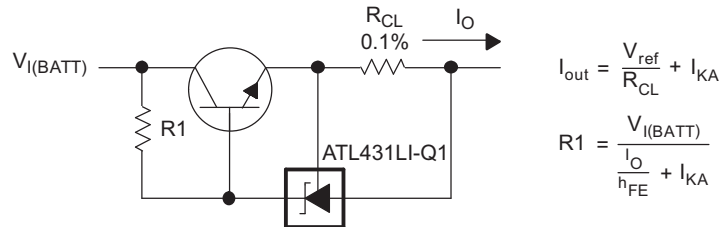
When using ATL43xLI-Q1 as a Linear Regulator to supply a load, designers typically use a bypass capacitor on the output/cathode pin. When doing this, be sure that the capacitance is within the stability criteria shown in [Figure 13](#).

To not exceed the maximum cathode current, be sure that the supply voltage is current limited. Also, be sure to limit the current being driven into the Ref pin, so you do not exceed its absolute maximum rating.

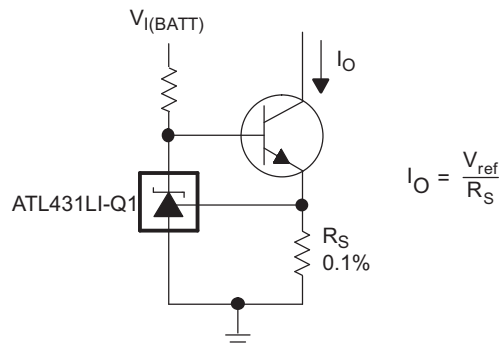
For applications shunting high currents, pay attention to the cathode and anode trace lengths, adjusting the width of the traces to have the proper current density.

12 Layout

12.1 Layout Guidelines

Bypass capacitors must be placed as close to the part as possible. Current-carrying traces need to have widths appropriate for the amount of current they are carrying; in the case of the ATL43xLI-Q1, these currents are low.

12.2 Layout Example



图 42. DBZ Layout Example

13 器件和文档支持

13.1 器件支持

13.1.1 器件命名规则

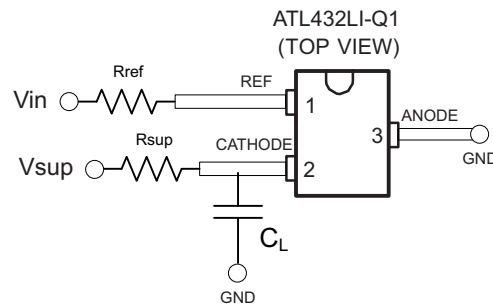
TI 通过分配后缀和前缀来区分 ATL43xLI-Q1 系列的所有组合。更多详细信息和可以订购的组合请参见“封装选项附录”。

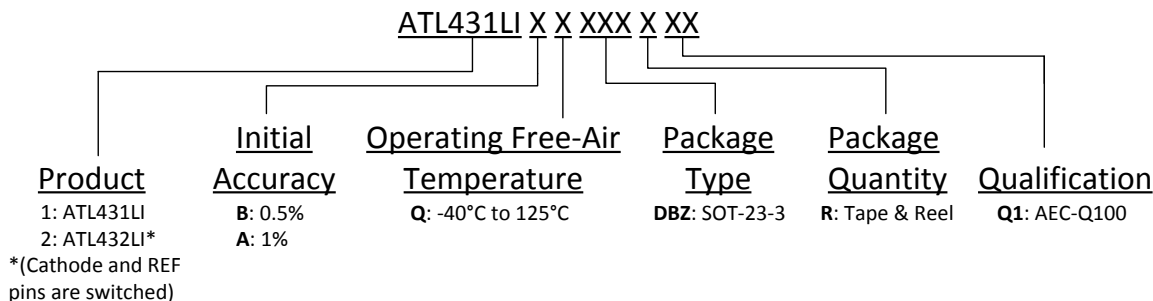

13.2 文档支持

13.2.1 相关文档

请参阅如下相关文档:

德州仪器 (TI), [《在可调节并联稳压器上设置并联电压》](#)

13.3 相关链接

下表列出了快速访问链接。类别包括技术文档、支持和社区资源、工具和软件，以及立即订购快速访问。

表 6. 相关链接

器件	产品文件夹	立即订购	技术文档	工具与软件	支持和社区
ATL431LI-Q1	单击此处	单击此处	单击此处	单击此处	单击此处
ATL432LI-Q1	单击此处	单击此处	单击此处	单击此处	单击此处

13.4 接收文档更新通知

要接收文档更新通知，请导航至 ti.com 上的器件产品文件夹。单击右上角的通知我进行注册，即可每周接收产品信息更改摘要。有关更改的详细信息，请查看任何已修订文档中包含的修订历史记录。

13.5 支持资源

TI E2E™ support forums are an engineer's go-to source for fast, verified answers and design help — straight from the experts. Search existing answers or ask your own question to get the quick design help you need.

Linked content is provided "AS IS" by the respective contributors. They do not constitute TI specifications and do not necessarily reflect TI's views; see TI's [Terms of Use](#).

13.6 商标

E2E is a trademark of Texas Instruments.

All other trademarks are the property of their respective owners.

13.7 静电放电警告



ESD 可能会损坏该集成电路。德州仪器 (TI) 建议通过适当的预防措施处理所有集成电路。如果不遵守正确的处理措施和安装程序，可能会损坏集成电路。

ESD 的损坏小至导致微小的性能降级，大至整个器件故障。精密的集成电路可能更容易受到损坏，这是因为非常细微的参数更改都可能会导致器件与其发布的规格不相符。

13.8 Glossary

[SLYZ022](#) — *TI Glossary*.

This glossary lists and explains terms, acronyms, and definitions.

14 机械、封装和可订购信息

以下页面包含机械、封装和可订购信息。这些信息是指定器件的最新可用数据。数据如有变更，恕不另行通知，且不会对此文档进行修订。如需获取此数据表的浏览器版本，请查阅左侧的导航栏。

PACKAGING INFORMATION

Orderable part number	Status (1)	Material type (2)	Package Pins	Package qty Carrier	RoHS (3)	Lead finish/ Ball material (4)	MSL rating/ Peak reflow (5)	Op temp (°C)	Part marking (6)
ATL431LIAQDBZRQ1	Active	Production	SOT-23 (DBZ) 3	3000 LARGE T&R	Yes	NIPDAU	Level-1-260C-UNLIM	-40 to 125	22XP
ATL431LIAQDBZRQ1.B	Active	Production	SOT-23 (DBZ) 3	3000 LARGE T&R	Yes	NIPDAU	Level-1-260C-UNLIM	-40 to 125	22XP
ATL431LIBQDBZRQ1	Active	Production	SOT-23 (DBZ) 3	3000 LARGE T&R	Yes	NIPDAU	Level-1-260C-UNLIM	-40 to 125	22ZP
ATL431LIBQDBZRQ1.B	Active	Production	SOT-23 (DBZ) 3	3000 LARGE T&R	Yes	NIPDAU	Level-1-260C-UNLIM	-40 to 125	22ZP
ATL432LIAQDBZRQ1	Active	Production	SOT-23 (DBZ) 3	3000 LARGE T&R	Yes	NIPDAU	Level-1-260C-UNLIM	-40 to 125	23AP
ATL432LIAQDBZRQ1.B	Active	Production	SOT-23 (DBZ) 3	3000 LARGE T&R	Yes	NIPDAU	Level-1-260C-UNLIM	-40 to 125	23AP
ATL432LIBQDBZRQ1	Active	Production	SOT-23 (DBZ) 3	3000 LARGE T&R	Yes	NIPDAU	Level-1-260C-UNLIM	-40 to 125	23BP
ATL432LIBQDBZRQ1.B	Active	Production	SOT-23 (DBZ) 3	3000 LARGE T&R	Yes	NIPDAU	Level-1-260C-UNLIM	-40 to 125	23BP

(1) **Status:** For more details on status, see our [product life cycle](#).

(2) **Material type:** When designated, preproduction parts are prototypes/experimental devices, and are not yet approved or released for full production. Testing and final process, including without limitation quality assurance, reliability performance testing, and/or process qualification, may not yet be complete, and this item is subject to further changes or possible discontinuation. If available for ordering, purchases will be subject to an additional waiver at checkout, and are intended for early internal evaluation purposes only. These items are sold without warranties of any kind.

(3) **RoHS values:** Yes, No, RoHS Exempt. See the [TI RoHS Statement](#) for additional information and value definition.

(4) **Lead finish/Ball material:** Parts may have multiple material finish options. Finish options are separated by a vertical ruled line. Lead finish/Ball material values may wrap to two lines if the finish value exceeds the maximum column width.

(5) **MSL rating/Peak reflow:** The moisture sensitivity level ratings and peak solder (reflow) temperatures. In the event that a part has multiple moisture sensitivity ratings, only the lowest level per JEDEC standards is shown. Refer to the shipping label for the actual reflow temperature that will be used to mount the part to the printed circuit board.

(6) **Part marking:** There may be an additional marking, which relates to the logo, the lot trace code information, or the environmental category of the part.

Multiple part markings will be inside parentheses. Only one part marking contained in parentheses and separated by a "-" will appear on a part. If a line is indented then it is a continuation of the previous line and the two combined represent the entire part marking for that device.

Important Information and Disclaimer: The information provided on this page represents TI's knowledge and belief as of the date that it is provided. TI bases its knowledge and belief on information provided by third parties, and makes no representation or warranty as to the accuracy of such information. Efforts are underway to better integrate information from third parties. TI has taken and continues to take reasonable steps to provide representative and accurate information but may not have conducted destructive testing or chemical analysis on incoming materials and chemicals. TI and TI suppliers consider certain information to be proprietary, and thus CAS numbers and other limited information may not be available for release.

In no event shall TI's liability arising out of such information exceed the total purchase price of the TI part(s) at issue in this document sold by TI to Customer on an annual basis.

OTHER QUALIFIED VERSIONS OF ATL431LI-Q1, ATL432LI-Q1 :

- Catalog : [ATL431LI](#), [ATL432LI](#)

NOTE: Qualified Version Definitions:

- Catalog - TI's standard catalog product

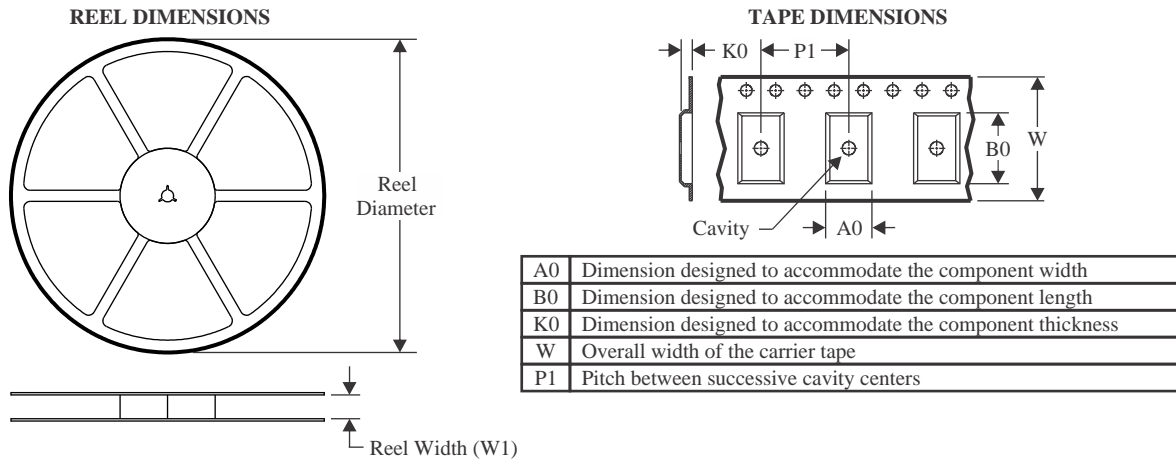
TAPE AND REEL INFORMATION

QUADRANT ASSIGNMENTS FOR PIN 1 ORIENTATION IN TAPE

*All dimensions are nominal

Device	Package Type	Package Drawing	Pins	SPQ	Reel Diameter (mm)	Reel Width W1 (mm)	A0 (mm)	B0 (mm)	K0 (mm)	P1 (mm)	W (mm)	Pin1 Quadrant
ATL431LIAQDBZRQ1	SOT-23	DBZ	3	3000	180.0	8.4	2.9	3.35	1.35	4.0	8.0	Q3
ATL431LIAQDBZRQ1	SOT-23	DBZ	3	3000	178.0	9.0	3.15	2.77	1.22	4.0	8.0	Q3
ATL431LIBQDBZRQ1	SOT-23	DBZ	3	3000	180.0	8.4	2.9	3.35	1.35	4.0	8.0	Q3
ATL431LIBQDBZRQ1	SOT-23	DBZ	3	3000	178.0	9.0	3.15	2.77	1.22	4.0	8.0	Q3
ATL432LIAQDBZRQ1	SOT-23	DBZ	3	3000	178.0	9.0	3.15	2.77	1.22	4.0	8.0	Q3
ATL432LIBQDBZRQ1	SOT-23	DBZ	3	3000	178.0	9.0	3.15	2.77	1.22	4.0	8.0	Q3

TAPE AND REEL BOX DIMENSIONS

*All dimensions are nominal

Device	Package Type	Package Drawing	Pins	SPQ	Length (mm)	Width (mm)	Height (mm)
ATL431LIAQDBZRQ1	SOT-23	DBZ	3	3000	210.0	185.0	35.0
ATL431LIAQDBZRQ1	SOT-23	DBZ	3	3000	180.0	180.0	18.0
ATL431LIBQDBZRQ1	SOT-23	DBZ	3	3000	210.0	185.0	35.0
ATL431LIBQDBZRQ1	SOT-23	DBZ	3	3000	180.0	180.0	18.0
ATL432LIAQDBZRQ1	SOT-23	DBZ	3	3000	180.0	180.0	18.0
ATL432LIBQDBZRQ1	SOT-23	DBZ	3	3000	180.0	180.0	18.0

EXAMPLE BOARD LAYOUT

DBZ0003A

SOT-23 - 1.12 mm max height

SMALL OUTLINE TRANSISTOR

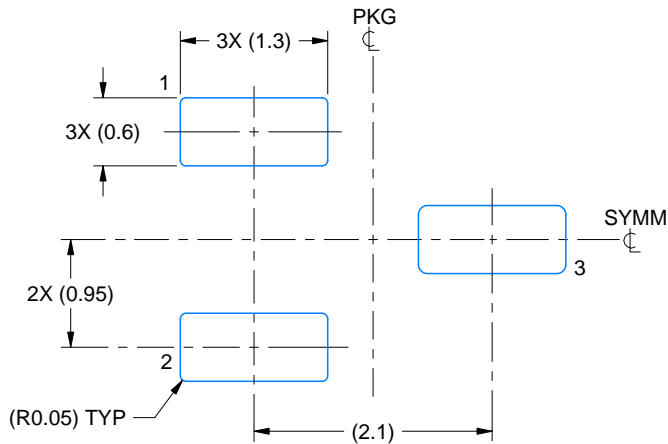

LAND PATTERN EXAMPLE
SCALE:15X

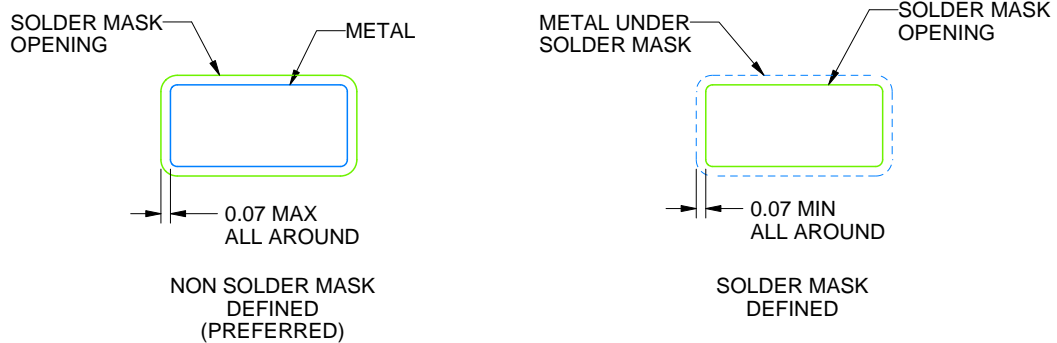

SOLDER MASK DETAILS

4214838/F 08/2024

NOTES: (continued)

5. Publication IPC-7351 may have alternate designs.
6. Solder mask tolerances between and around signal pads can vary based on board fabrication site.

EXAMPLE STENCIL DESIGN

DBZ0003A

SOT-23 - 1.12 mm max height

SMALL OUTLINE TRANSISTOR

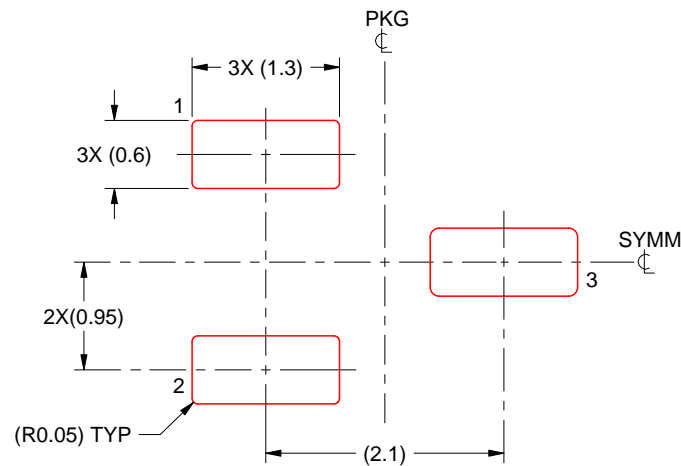

SOLDER PASTE EXAMPLE
BASED ON 0.125 THICK STENCIL
SCALE:15X

4214838/F 08/2024

NOTES: (continued)

7. Laser cutting apertures with trapezoidal walls and rounded corners may offer better paste release. IPC-7525 may have alternate design recommendations.
8. Board assembly site may have different recommendations for stencil design.

重要通知和免责声明

TI“按原样”提供技术和可靠性数据（包括数据表）、设计资源（包括参考设计）、应用或其他设计建议、网络工具、安全信息和其他资源，不保证没有瑕疵且不做任何明示或暗示的担保，包括但不限于对适销性、与某特定用途的适用性或不侵犯任何第三方知识产权的暗示担保。

这些资源可供使用 TI 产品进行设计的熟练开发人员使用。您将自行承担以下全部责任：(1) 针对您的应用选择合适的 TI 产品，(2) 设计、验证并测试您的应用，(3) 确保您的应用满足相应标准以及任何其他安全、安保法规或其他要求。

这些资源如有变更，恕不另行通知。TI 授权您仅可将这些资源用于研发本资源所述的 TI 产品的相关应用。严禁以其他方式对这些资源进行复制或展示。您无权使用任何其他 TI 知识产权或任何第三方知识产权。对于因您对这些资源的使用而对 TI 及其代表造成的任何索赔、损害、成本、损失和债务，您将全额赔偿，TI 对此概不负责。

TI 提供的产品受 [TI 销售条款](#)、[TI 通用质量指南](#) 或 [ti.com](#) 上其他适用条款或 TI 产品随附的其他适用条款的约束。TI 提供这些资源并不会扩展或以其他方式更改 TI 针对 TI 产品发布的适用的担保或担保免责声明。除非德州仪器 (TI) 明确将某产品指定为定制产品或客户特定产品，否则其产品均为按确定价格收入目录的标准通用器件。

TI 反对并拒绝您可能提出的任何其他或不同的条款。

版权所有 © 2026，德州仪器 (TI) 公司

最后更新日期：2025 年 10 月