

bq27742-G1 具有可编程硬件保护功能的单节锂离子电池电量监测计

1 特性

- 单节锂离子电池电量监测计和保护器 应用
- 微控制器外设提供：
 - 具有低值感应电阻（5mΩ 至 20mΩ）的精密 16 位高侧库仑计数器
 - 用于报告电池温度的外部和内部温度传感器
 - 使用寿命和电流数据记录
 - 64 字节非易失性暂用闪存
 - 通过 SHA-1 认证
- 基于已获专利的 Impedance Track™ 技术的电池电量计量
 - 用于电池续航能力精确预测的电池放电模拟曲线
 - 针对电池老化、自放电和温度以及额定引入效应的自动调节
- 集成高侧 NMOS 保护场效应晶体管 (FET) 驱动
- 基于硬件的安全与防护功能：
 - 过压保护 (OVP)
 - 欠压保护 (UVP)
 - 充电过流 (OCC)
 - 放电过流 (OCD)
 - 放电短路 (SCD)
- 采用 I²C 和 HDQ 通信接口格式，用于与主机系统通信
- 超紧凑 15 焊球 NanoFree™ DSBGA

2 应用

- 智能手机
- 平板电脑
- 手持式终端
- MP3 和多媒体播放器
- 便携式游戏机

3 说明

德州仪器 (TI) bq27742-G1 器件是一款电量监测计，适用于单节锂离子电池组。此电量计使用已获专利的 Impedance Track™ 技术，可预测剩余电池电量和系统运行的速率、温度和老化补偿并且具有最高精度。此器件还含有一个完全集成的高侧保护器，无需单独的锂离子保护电路即可对是否存在过压、欠压、充电过流、放电过流和放电短路条件进行全套高精度故障检测。硬件保护功能提供了内置数据闪存可编程功能，方便针对不同的终端设备需求重新配置现有器件。

这款电量监测计可提供剩余电池电量 (mAh)、充电状态 (%)、续航时间 (分钟)、电池电压 (mV)、电流 (mA) 和温度 (°C) 等信息，以及整个电池使用寿命期间记录的重要参数。此器件还支持中断主机，指示检测到各种重要的故障条件并汇报给系统。

DSBGA 是 15 焊球封装 (2.78mm × 1.96mm)，非常适合空间受限的应用。

器件信息⁽¹⁾

器件型号	封装	封装尺寸 (标称值)
BQ27742YZFR-G1	YZF (15)	2.78mm x 1.96mm
BQ27742YZFT-G1		

(1) 如需了解所有可用封装，请参阅数据表末尾的可订购产品附录。

简化原理图

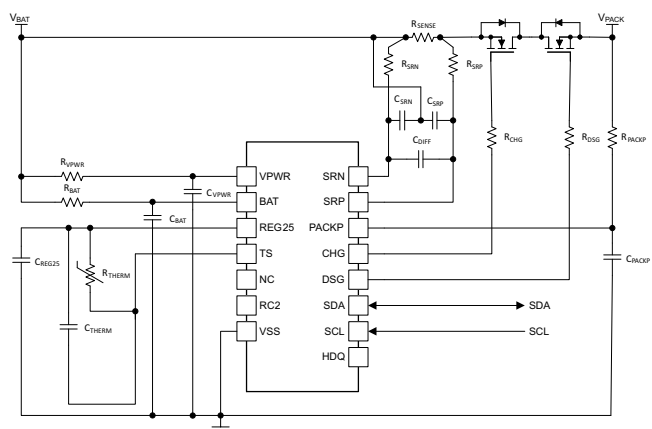

Copyright © 2017, Texas Instruments Incorporated



目录

1	特性	1			
2	应用	1			
3	说明	1			
4	修订历史记录	2			
5	Pin Configuration and Functions	3			
6	Specifications	6			
6.1	Absolute Maximum Ratings	6			
6.2	ESD Ratings	6			
6.3	Recommended Operating Conditions	6			
6.4	Thermal Information	7			
6.5	Power-On Reset	7			
6.6	2.5-V LDO Regulator	7			
6.7	Charger Attachment and Removal Detection	8			
6.8	CHG and DSG FET Drive	8			
6.9	Overvoltage Protection (OVP)	8			
6.10	Undervoltage Protection (UVP)	8			
6.11	Overcurrent in Discharge (OCD)	9			
6.12	Overcurrent in Charge (OCC)	9			
6.13	Short-Circuit in Discharge (SCD)	9			
6.14	Low Voltage Charging	9			
6.15	Internal Temperature Sensor Characteristics	9			
6.16	High-Frequency Oscillator	10			
6.17	Low-Frequency Oscillator	10			
6.18	Integrating ADC (Coulomb Counter) Characteristics	10			
6.19	ADC (Temperature and Cell Voltage) Characteristics	10			
6.20	Data Flash Memory Characteristics	11			
6.21	Timing Requirements	11			
6.22	Typical Characteristics	13			
7	Detailed Description	15			
7.1	Overview	15			
7.2	Functional Block Diagram	15			
7.3	Feature Description	16			
7.4	Device Functional Modes	18			
7.5	Battery Parameter Measurements	21			
7.6	Communications	22			
7.7	Standard Data Commands	24			
7.8	Extended Data Commands	26			
8	Application and Implementation	27			
8.1	Application Information	27			
8.2	Typical Applications	27			
9	Power Supply Recommendation	35			
9.1	Power Supply Decoupling	35			
10	Layout	36			
10.1	Layout Guidelines	36			
10.2	Layout Example	37			
11	器件和文档支持	38			
11.1	文档支持	38			
11.2	接收文档更新通知	38			
11.3	社区资源	38			
11.4	商标	38			
11.5	静电放电警告	38			
11.6	Glossary	38			
12	机械、封装和可订购信息	38			

4 修订历史记录

注：之前版本的页码可能与当前版本有所不同。

Changes from Revision C (February 2016) to Revision D	Page
• Changed Detailed Description	15
• Changed Standard Commands	25
• 已添加 接收文档更新通知	38

Changes from Revision B (August 2015) to Revision C	Page
• 已更改 封装标签“CSP”全部改为“DSBGA”	1
• Changed Integrating ADC (Coulomb Counter) Characteristics	10

Changes from Revision A (December 2014) to Revision B	Page
• Changed Pin Functions	3
• Changed Absolute Maximum Ratings	6
• Changed Recommended Operating Conditions	7
• Changed Functional Block Diagram	15
• Changed V_{VPWR} to V_{BAT} in Figure 15	19
• Changed " V_{PWR} " to " V_{BAT} " in OVERVOLTAGE Mode and UNDERVOLTAGE Mode	20

5 Pin Configuration and Functions

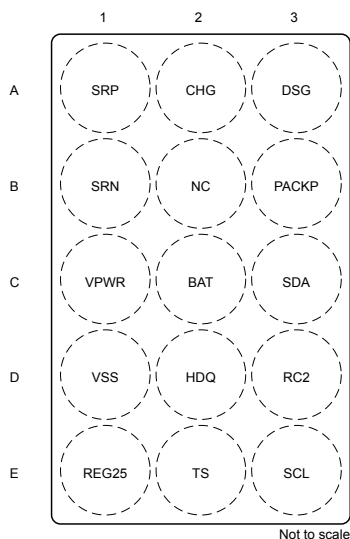

Pin Functions

NUMBER	NAME	I/O	DESCRIPTION
A1	SRP	I	Analog input pin connected to the internal coulomb counter where SRP is nearest the PACK+ connection. Connect to a sense resistor.
A2	CHG	O	External high side N-channel charge FET driver
A3	DSG	O	External high side N-channel discharge FET driver
B1	SRN	I	Analog input pin connected to the internal coulomb counter where SRN is nearest the CELL+ connection. Connect to a sense resistor.
B2	NC	IO	Not used. Reserved for future GPIO. It is recommended to connect to GND.
B3	PACKP	I	Pack voltage measurement input for protector operation
C1	VPWR	—	Power input. Decouple with 0.1- μ F ceramic capacitor to V_{SS} .
C2	BAT	I	Cell-voltage measurement input. ADC input
C3	SDA	IO	Slave I ² C serial communications data line for communication with system. Open-drain I/O. Use with a 10-k Ω pullup resistor (typical).
D1	VSS	—	Device ground
D2	HDQ	I/O	HDQ serial communications line. Open-drain
D3	RC2	IO	General purpose IO. Push-pull output
E1	REG25	—	Regulator output and bq27742-G1 processor power. Decouple with 1.0- μ F ceramic capacitor to V_{SS} .
E2	TS	I	Pack thermistor voltage sense (use 103AT-type thermistor). ADC input
E3	SCL	IO	Slave I ² C serial communications clock input line for communication with system. Use with a 10-k Ω pullup resistor (typical).

Table 1. Hardware Protection Thresholds⁽¹⁾

OVERVOLTAGE PROTECTION (V_{OVP})	UNDERVOLTAGE PROTECTION (V_{UVP})	OVERCURRENT IN CHARGE (V_{OCC})	OVERCURRENT IN DISCHARGE (V_{OCD})	SHORT-CIRCUIT IN DISCHARGE (V_{SCD})
4.450 V	2.438 V	6 mV	14 mV	73 mV
			24 mV	
		13 mV	34 mV	
			44 mV	
		18 mV	53 mV	148 mV
			63 mV	
28 mV	73 mV			
	83 mV			
4.425 V	2.422 V	6 mV	13 mV	73 mV
			23 mV	
		13 mV	33 mV	
			43 mV	
		18 mV	53 mV	148 mV
			63 mV	
28 mV	72 mV			
	83 mV			
4.400 V	2.409 V	6 mV	13 mV	72 mV
			23 mV	
		13 mV	33 mV	
			43 mV	
		18 mV	52 mV	147 mV
			62 mV	
28 mV	72 mV			
	82 mV			
4.375 V	2.395 V	6 mV	13 mV	72 mV
			23 mV	
		13 mV	33 mV	
			42 mV	
		18 mV	52 mV	146 mV
			62 mV	
28 mV	72 mV			
	82 mV			
4.350 V	2.381 V	6 mV	13 mV	71 mV
			23 mV	
		13 mV	32 mV	
			42 mV	
		18 mV	52 mV	145 mV
			62 mV	
28 mV	71 mV			
	81 mV			

 (1) Production tested in the following configuration: $V_{OVP} = 4.450$ V, $V_{UVP} = 2.438$ V, $V_{OCC} = 28$ mV, $V_{OCD} = 83$ mV, and $V_{SCD} = 148$ mV.

Table 1. Hardware Protection Thresholds⁽¹⁾ (continued)

OVERVOLTAGE PROTECTION (V_{OVP})	UNDERVOLTAGE PROTECTION (V_{UVP})	OVERCURRENT IN CHARGE (V_{OCC})	OVERCURRENT IN DISCHARGE (V_{OCD})	SHORT-CIRCUIT IN DISCHARGE (V_{SCD})
4.325 V	2.368 V	6 mV	13 mV	71 mV
			22 mV	
		13 mV	32 mV	
			42 mV	
		18 mV	52 mV	144 mV
			61 mV	
27 mV	71 mV			
	81 mV			
4.300 V	2.354 V	6 mV	13 mV	71 mV
			22 mV	
		13 mV	32 mV	
			42 mV	
		18 mV	51 mV	143 mV
			61 mV	
27 mV	70 mV			
	80 mV			
4.275 V	2.340 V	6 mV	13 mV	70 mV
			22 mV	
		13 mV	32 mV	
			41 mV	
		18 mV	51 mV	143 mV
			60 mV	
27 mV	70 mV			
	80 mV			

Table 2. Hardware Protection Delays

OVERVOLTAGE PROTECTION DELAY (t_{OVP})	UNDERVOLTAGE PROTECTION DELAY (t_{UVP})	OVERCURRENT IN CHARGE DELAY (t_{OCC})	OVERCURRENT IN DISCHARGE DELAY (t_{OCD})	SHORT-CIRCUIT IN DISCHARGE DELAY (t_{SCD})
1.00 s	31.25 ms	7.81 ms	31.25 ms	312.50 μ s

6 Specifications

6.1 Absolute Maximum Ratings

 over operating free-air temperature range (unless otherwise noted)⁽¹⁾

		MIN	MAX	UNIT
V _{VPWR}	Power input range	-0.3	5.5	V
V _{REG25}	Supply voltage range	-0.3	2.75	V
V _{PACKP}	PACKP input pin	-0.3	5.5	V
	PACK+ input when external 2-kΩ resistor is in series with PACKP input pin (see Figure 19 and Figure 20)	-0.3	28	V
V _{OUT}	Voltage output pins (DSG, CHG)	-0.3	10	V
V _{IOD1}	Push-pull IO pins (RC2)	-0.3	2.75	V
V _{IOD2}	Open-drain IO pins (SDA, SCL, HDQ, NC)	-0.3	5.5	V
V _{BAT}	BAT input pin	-0.3	5.5	V
V _I	Input voltage range to all other pins (SRP, SRN)	-0.3	5.5	V
V _{TS}	Input voltage range for TS	-0.3	2.75	V
T _A	Operating free-air temperature	-40	85	°C
T _F	Functional temperature	-40	100	°C
T _{stg}	Storage temperature range	-65	150	°C

(1) Stresses beyond those listed under *Absolute Maximum Ratings* may cause permanent damage to the device. These are stress ratings only, which do not imply functional operation of the device at these or any other conditions beyond those indicated under *Recommended Operating Conditions*. Exposure to absolute-maximum-rated conditions for extended periods may affect device reliability.

6.2 ESD Ratings

			VALUE	UNIT
V _(ESD)	Electrostatic discharge	Human-body model (HBM), per ANSI/ESDA/JEDEC JS-001 ⁽¹⁾	±1000	V
		Charged-device model (CDM), per JEDEC specification JESD22-C101 ⁽²⁾	±250	

(1) JEDEC document JEP155 states that 500-V HBM allows safe manufacturing with a standard ESD control process.

(2) JEDEC document JEP157 states that 250-V CDM allows safe manufacturing with a standard ESD control process.

6.3 Recommended Operating Conditions

 T_A = 25°C, C_{REG25} = 1.0 μF, and V_{VPWR} = 3.6 V (unless otherwise noted)

PARAMETER	TEST CONDITION	MIN	NOM	MAX	UNIT
V _{VPWR}	Supply voltage	No operating restrictions		5.0	V
		No FLASH writes		2.8	
C _{VPWR}	External input capacitor for internal LDO between VPWR and V _{SS}	Nominal capacitor values specified. Recommend a 5% ceramic X5R type capacitor located close to the device		0.1	μF
C _{REG25}	External output capacitor for internal LDO between REG25 and V _{SS}	0.47	1.0		μF
I _{CC}	NORMAL operating mode current ⁽¹⁾⁽²⁾ (VPWR)	Fuel gauge in NORMAL mode I _{LOAD} > Sleep Current with charge pumps on (FETs on)		167	μA
I _{SLP}	SLEEP mode current ⁽¹⁾⁽²⁾ (VPWR)	Fuel gauge in SLEEP+ mode. I _{LOAD} < Sleep Current with charge pumps on (FETs on)		88	μA
I _{FULLSLP}	FULLSLEEP mode current ⁽¹⁾⁽²⁾ (VPWR)	Fuel gauge in SLEEP mode. I _{LOAD} < Sleep Current with charge pumps on (FETs on)		40	μA

(1) All currents are specified with charge pump on (FETs on).

(2) All currents are continuous average over 5-second period.

Recommended Operating Conditions (continued)

 $T_A = 25^\circ\text{C}$, $C_{\text{REG25}} = 1.0 \mu\text{F}$, and $V_{\text{VPWR}} = 3.6 \text{ V}$ (unless otherwise noted)

PARAMETER	TEST CONDITION	MIN	NOM	MAX	UNIT
I_{SHUTDOWN}	SHUTDOWN mode current ⁽¹⁾⁽²⁾ (VPWR)		0.1	0.2	μA
	Fuel gauge in SHUTDOWN mode. UVP tripped with fuel gauge and protector turned off (FETs off) $V_{\text{VPWR}} = 2.5 \text{ V}$ $T_A = 25^\circ\text{C}$ $T_A = -40^\circ\text{C}$ to 85°C			0.5	μA
V_{OL}	Output voltage low (SCL, SDA, HDQ, NC, RC2)			0.4	V
$V_{\text{OH(OD)}}$	Output voltage high (SDA, SCL, HDQ, NC, RC2)	External pullup resistor connected to V_{REG25}	$V_{\text{REG25}} - 0.5$		V
V_{IL}	Input voltage low (SDA, SCL, HDQ, NC)		-0.3	0.6	V
$V_{\text{IH(OD)}}$	Input voltage high (SDA, SCL, HDQ, NC)		1.2	5.5	V
V_{A1}	Input voltage range (TS)		$V_{\text{SS}} - 0.125$	2	V
V_{A2}	Input voltage range (BAT)		$V_{\text{SS}} - 0.125$	5	V
V_{A3}	Input voltage range (SRP, SRN)		$V_{\text{VPWR}} - 0.125$	$V_{\text{VPWR}} + 0.125$	V
I_{Ikg}	Input leakage current (I/O pins)			0.3	μA
t_{PUCD}	Power-up communication delay		250		ms

6.4 Thermal Information

THERMAL METRIC ⁽¹⁾	bq27742-G1 YZF (DSBGA)	UNIT
	15 PINS	
$R_{\theta\text{JA}}$ Junction-to-ambient thermal resistance	70	$^\circ\text{C/W}$
$R_{\theta\text{Jctop}}$ Junction-to-case (top) thermal resistance	17	$^\circ\text{C/W}$
$R_{\theta\text{JB}}$ Junction-to-board thermal resistance	20	$^\circ\text{C/W}$
Ψ_{JT} Junction-to-top characterization parameter	1	$^\circ\text{C/W}$
Ψ_{JB} Junction-to-board characterization parameter	18	$^\circ\text{C/W}$
$R_{\theta\text{Jcbot}}$ Junction-to-case (bottom) thermal resistance	NA	$^\circ\text{C/W}$

(1) For more information about traditional and new thermal metrics, see the IC Package Thermal Metrics application report, [SPRA953](#).

6.5 Power-On Reset

 $T_A = 25^\circ\text{C}$, $C_{\text{REG25}} = 1.0 \mu\text{F}$, and $V_{\text{VPWR}} = 3.6 \text{ V}$ (unless otherwise noted)

PARAMETER	TEST CONDITIONS	MIN	TYP	MAX	UNIT
$V_{\text{IT+}}$	Increasing battery voltage input at V_{REG25}	2.09	2.20	2.31	V
V_{HYS}	Power-on reset hysteresis	45	115	185	mV

6.6 2.5-V LDO Regulator⁽¹⁾

 $T_A = 25^\circ\text{C}$, $C_{\text{REG25}} = 1.0 \mu\text{F}$, and $V_{\text{VPWR}} = 3.6 \text{ V}$ (unless otherwise noted)

PARAMETER	TEST CONDITIONS	MIN	TYP	MAX	UNIT
V_{REG25}	Regulator output voltage $2.8 \text{ V} \leq V_{\text{VPWR}} \leq 4.5 \text{ V}$, $I_{\text{OUT}}^{(1)} \leq 16 \text{ mA}$	2.3	2.5	2.6	V
	$2.45 \text{ V} \leq V_{\text{VPWR}} < 2.8 \text{ V}$ (low battery), $I_{\text{OUT}}^{(1)} \leq 3 \text{ mA}$	2.3			V

(1) LDO output current, I_{OUT} , is the sum of internal and external load currents.

2.5-V LDO Regulator⁽¹⁾ (continued)

 $T_A = 25^\circ\text{C}$, $C_{\text{REG25}} = 1.0\ \mu\text{F}$, and $V_{\text{VPWR}} = 3.6\ \text{V}$ (unless otherwise noted)

PARAMETER	TEST CONDITIONS	MIN	TYP	MAX	UNIT
$I_{\text{SHORT}}^{(2)}$ Short-circuit current limit	$V_{\text{REG25}} = 0\ \text{V}$ $T_A = -40^\circ\text{C}$ to 85°C			250	mA

(2) Assured by characterization. Not production tested.

6.7 Charger Attachment and Removal Detection

 $T_A = 25^\circ\text{C}$, $C_{\text{REG25}} = 1.0\ \mu\text{F}$, and $V_{\text{VPWR}} = 3.6\ \text{V}$ (unless otherwise noted)

PARAMETER	TEST CONDITIONS	MIN	TYP	MAX	UNIT
V_{CHGATT} Voltage threshold for charger attachment detection			2.7	3.0	V
V_{CHGREM} Voltage threshold for charger removal detection		0.5	1.0		V

6.8 CHG and DSG FET Drive

 $T_A = 25^\circ\text{C}$, $C_{\text{REG25}} = 1.0\ \mu\text{F}$, and $V_{\text{VPWR}} = 3.6\ \text{V}$ (unless otherwise noted)

PARAMETER	TEST CONDITIONS	MIN	TYP	MAX	UNIT
V_{FETON} CHG and DSG FETs on	$I_L = 1\ \mu\text{A}$ $T_A = -40^\circ\text{C}$ to 85°C	$2 \times V_{\text{VPWR}} - 0.4$	$2 \times V_{\text{VPWR}} - 0.2$	$2 \times V_{\text{VPWR}}$	V
V_{FETOFF} CHG and DSG FETs off	$T_A = -40^\circ\text{C}$ to 85°C			0.2	V
$V_{\text{FETRIPPLE}}^{(1)}$ CHG and DSG FETs on	$I_L = 1\ \mu\text{A}$ $T_A = -40^\circ\text{C}$ to 85°C			0.1	V_{PP}
t_{FETON} FET gate rise time (10% to 90%)	$C_L = 4\ \text{nF}$ $T_A = -40^\circ\text{C}$ to 85°C No series resistance	67	140	218	μs
t_{FETOFF} FET gate fall time (90% to 10%)	$C_L = 4\ \text{nF}$ $T_A = -40^\circ\text{C}$ to 85°C No series resistance	10	30	60	μs

(1) Assured by characterization. Not production tested.

6.9 Overvoltage Protection (OVP)

 $T_A = 25^\circ\text{C}$ and $C_{\text{REG25}} = 1.0\ \mu\text{F}$ (unless otherwise noted)

PARAMETER	TEST CONDITIONS	MIN	TYP	MAX	UNIT
V_{OVP} OVP detection voltage threshold	$T_A = 25^\circ\text{C}$	$V_{\text{OVP}} - 0.016$	V_{OVP}	$V_{\text{OVP}} + 0.016$	V
	$T_A = 0^\circ\text{C}$ to 25°C	$V_{\text{OVP}} - 0.033$	V_{OVP}	$V_{\text{OVP}} + 0.030$	
	$T_A = 25^\circ\text{C}$ to 50°C	$V_{\text{OVP}} - 0.028$	V_{OVP}	$V_{\text{OVP}} + 0.024$	
	$T_A = -40^\circ\text{C}$ to 85°C	$V_{\text{OVP}} - 0.063$	V_{OVP}	$V_{\text{OVP}} + 0.045$	
V_{OVPREL} OVP release voltage	$T_A = 25^\circ\text{C}$	$V_{\text{OVPREL}} - 0.022$	$V_{\text{OVP}} - 0.215$	$V_{\text{OVPREL}} + 0.022$	V
	$T_A = 0^\circ\text{C}$ to 25°C	$V_{\text{OVPREL}} - 0.033$	$V_{\text{OVP}} - 0.215$	$V_{\text{OVPREL}} + 0.030$	
	$T_A = 25^\circ\text{C}$ to 50°C	$V_{\text{OVPREL}} - 0.028$	$V_{\text{OVP}} - 0.215$	$V_{\text{OVPREL}} + 0.024$	
	$T_A = -40^\circ\text{C}$ to 85°C	$V_{\text{OVPREL}} - 0.063$	$V_{\text{OVP}} - 0.215$	$V_{\text{OVPREL}} + 0.045$	
t_{OVP} OVP delay time	$T_A = -40^\circ\text{C}$ to 85°C	$t_{\text{OVP}} - 5\%$	t_{OVP}	$t_{\text{OVP}} + 5\%$	s

6.10 Undervoltage Protection (UVP)

 $T_A = 25^\circ\text{C}$ and $C_{\text{REG25}} = 1.0\ \mu\text{F}$ (unless otherwise noted)

PARAMETER	TEST CONDITIONS	MIN	TYP	MAX	UNIT
V_{UVP} UVP detection voltage threshold	$T_A = 25^\circ\text{C}$	$V_{\text{UVP}} - 0.022$	V_{UVP}	$V_{\text{UVP}} + 0.022$	V
	$T_A = -5^\circ\text{C}$ to 50°C	$V_{\text{UVP}} - 0.030$	V_{UVP}	$V_{\text{UVP}} + 0.030$	
	$T_A = -40^\circ\text{C}$ to 85°C	$V_{\text{UVP}} - 0.050$	V_{UVP}	$V_{\text{UVP}} + 0.050$	

Undervoltage Protection (UVP) (continued)

 $T_A = 25^\circ\text{C}$ and $C_{\text{REG25}} = 1.0\ \mu\text{F}$ (unless otherwise noted)

PARAMETER		TEST CONDITIONS	MIN	TYP	MAX	UNIT
V_{UVPREL}	UVP release voltage	$T_A = 25^\circ\text{C}$	$V_{\text{UVPREL}} - 0.022$	$V_{\text{UVP}} + 0.105$	$V_{\text{UVPREL}} + 0.022$	V
		$T_A = -5^\circ\text{C}$ to 50°C	$V_{\text{UVPREL}} - 0.030$	$V_{\text{UVP}} + 0.105$	$V_{\text{UVPREL}} + 0.030$	
		$T_A = -40^\circ\text{C}$ to 85°C	$V_{\text{UVPREL}} - 0.050$	$V_{\text{UVP}} + 0.105$	$V_{\text{UVPREL}} + 0.050$	
t_{UVP}	UVP delay time	$T_A = -40^\circ\text{C}$ to 85°C	$t_{\text{UVP}} - 5\%$	t_{UVP}	$t_{\text{UVP}} + 5\%$	ms

6.11 Overcurrent in Discharge (OCD)

 $T_A = 25^\circ\text{C}$, $C_{\text{REG25}} = 1.0\ \mu\text{F}$, and $V_{\text{VPWR}} = 3.6\ \text{V}$ (unless otherwise noted)

PARAMETER		TEST CONDITIONS	MIN	TYP	MAX	UNIT
V_{OCD}	OCD detection voltage threshold	$T_A = 25^\circ\text{C}$ $V_{\text{SRN}} - V_{\text{SRP}}$	$V_{\text{OCD}} - 3$	V_{OCD}	$V_{\text{OCD}} + 3$	mV
		$T_A = -20^\circ\text{C}$ to 60°C $V_{\text{SRN}} - V_{\text{SRP}}$	$0.98 * V_{\text{OCD}} - 3.125$	V_{OCD}	$1.02 * V_{\text{OCD}} + 3.125$	
		$T_A = -40^\circ\text{C}$ to 85°C $V_{\text{SRN}} - V_{\text{SRP}}$	$0.98 * V_{\text{OCD}} - 3.5$	V_{OCD}	$1.02 * V_{\text{OCD}} + 3.5$	
t_{OCD}	OCD delay time	$T_A = -40^\circ\text{C}$ to 85°C	$t_{\text{OCD}} - 5\%$	t_{OCD}	$t_{\text{OCD}} + 5\%$	ms

6.12 Overcurrent in Charge (OCC)

 $T_A = 25^\circ\text{C}$, $C_{\text{REG25}} = 1.0\ \mu\text{F}$, and $V_{\text{VPWR}} = 3.6\ \text{V}$ (unless otherwise noted)

PARAMETER		TEST CONDITIONS	MIN	TYP	MAX	UNIT
V_{OCC}	OCC detection voltage threshold	$T_A = 25^\circ\text{C}$ $V_{\text{SRP}} - V_{\text{SRN}}$	$V_{\text{OCC}} - 3$	V_{OCC}	$V_{\text{OCC}} + 3$	mV
		$T_A = -20^\circ\text{C}$ to 60°C $V_{\text{SRP}} - V_{\text{SRN}}$	$0.98 * V_{\text{OCC}} - 3.125$	V_{OCC}	$1.02 * V_{\text{OCC}} + 3.125$	
		$T_A = -40^\circ\text{C}$ to 85°C $V_{\text{SRP}} - V_{\text{SRN}}$	$0.98 * V_{\text{OCC}} - 3.5$	V_{OCC}	$1.02 * V_{\text{OCC}} + 3.5$	
t_{OCC}	OCC delay time	$T_A = -40^\circ\text{C}$ to 85°C	$t_{\text{OCC}} - 5\%$	t_{OCC}	$t_{\text{OCC}} + 5\%$	ms

6.13 Short-Circuit in Discharge (SCD)

 $T_A = 25^\circ\text{C}$, $C_{\text{REG25}} = 1.0\ \mu\text{F}$, and $V_{\text{VPWR}} = 3.6\ \text{V}$ (unless otherwise noted)

PARAMETER		TEST CONDITIONS	MIN	TYP	MAX	UNIT
V_{SCD}	SCD detection voltage threshold	$T_A = 25^\circ\text{C}$ $V_{\text{SRN}} - V_{\text{SRP}}$	$V_{\text{SCD}} - 3$	V_{SCD}	$V_{\text{SCD}} + 3$	mV
		$T_A = -20^\circ\text{C}$ to 60°C $V_{\text{SRN}} - V_{\text{SRP}}$	$0.98 * V_{\text{SCD}} - 3.125$	V_{SCD}	$1.02 * V_{\text{SCD}} + 3.125$	
		$T_A = -40^\circ\text{C}$ to 85°C $V_{\text{SRN}} - V_{\text{SRP}}$	$0.98 * V_{\text{SCD}} - 3.5$	V_{SCD}	$1.02 * V_{\text{SCD}} + 3.5$	
t_{SCD}	SCD delay time	$T_A = -40^\circ\text{C}$ to 85°C	$t_{\text{SCD}} - 30\%$	t_{SCD}	$t_{\text{SCD}} + 30\%$	μs

6.14 Low Voltage Charging

 $T_A = 25^\circ\text{C}$, $C_{\text{REG25}} = 1.0\ \mu\text{F}$, and $V_{\text{VPWR}} = 3.6\ \text{V}$ (unless otherwise noted)

PARAMETER		TEST CONDITIONS	MIN	TYP	MAX	UNIT
V_{LVDET}	Voltage threshold for low-voltage charging detection	$T_A = -40^\circ\text{C}$ to 85°C	1.4	1.55	1.7	V

6.15 Internal Temperature Sensor Characteristics

 $T_A = -40^\circ\text{C}$ to 85°C , $2.4\ \text{V} < V_{\text{REG25}} < 2.6\ \text{V}$

PARAMETER		TEST CONDITIONS	MIN	TYP	MAX	UNIT
$G_{\text{(TEMP)}}$	Temperature sensor voltage gain			-2		mV/ $^\circ\text{C}$

6.16 High-Frequency Oscillator

2.4 V < V_{REG25} < 2.6 V; typical values at T_A = 25°C and V_{REG25} = 2.5 V (unless otherwise noted)

PARAMETER	TEST CONDITIONS	MIN	TYP	MAX	UNIT
f _{OSC} Operating frequency			8.389		MHz
f _{EIO} Frequency error ^{(1) (2)}	T _A = 0°C to 60°C	-2.0%	0.38%	2.0%	
	T _A = -20°C to 70°C	-3.0%	0.38%	3.0%	
	T _A = -40°C to 85°C	-4.5%	0.38%	4.5%	
t _{SXO} Start-up time ⁽³⁾	T _A = -40°C to 85°C		2.5	5	ms

(1) The frequency error is measured from 2.097 MHz.

(2) The frequency drift is included and measured from the trimmed frequency at V_{REG25} = 2.5 V, T_A = 25°C.

(3) The startup time is defined as the time it takes for the oscillator output frequency to be ±3% of the typical oscillator frequency.

6.17 Low-Frequency Oscillator

2.4 V < V_{REG25} < 2.6 V; typical values at T_A = 25°C and V_{REG25} = 2.5 V (unless otherwise noted)

PARAMETER	TEST CONDITIONS	MIN	TYP	MAX	UNIT
f _(LOSC) Operating frequency			32.768		kHz
f _(LEIO) Frequency error ^{(1) (2)}	T _A = 0°C to 60°C	-1.5%	0.25%	1.5%	
	T _A = -20°C to 70°C	-2.5%	0.25%	2.5%	
	T _A = -40°C to 85°C	-4.0%	0.25%	4.0%	
t _(LSXO) Start-up time ⁽³⁾	T _A = -40°C to 85°C		500		μs

(1) The frequency drift is included and measured from the trimmed frequency at V_{REG25} = 2.5 V, T_A = 25°C.

(2) The frequency error is measured from 32.768 kHz.

(3) The startup time is defined as the time it takes for the oscillator output frequency to be ±3% of the typical oscillator frequency.

6.18 Integrating ADC (Coulomb Counter) Characteristics

T_A = -40°C to 85°C, 2.4 V < V_{REG25} < 2.6 V; typical values at T_A = 25°C and V_{REG25} = 2.5 V (unless otherwise noted)

PARAMETER	TEST CONDITIONS	MIN	TYP	MAX	UNIT
V _{SR_IN} Input voltage range, V _{SRN} and V _{SRP}	V _{SR} = V _{SRP} - V _{SRN}	V _{VPWR} - 0.125		V _{VPWR} + 0.125	V
t _{SR_CONV} Conversion time	Single conversion		1		s
Resolution		14		15	bits
V _{SR_OS} Input offset			10		μV
INL Integral nonlinearity error			±0.007%	±0.034%	FSR
Z _{SR_IN} Effective input resistance ⁽¹⁾		7			MΩ
I _{SR_LKG} Input leakage current ⁽¹⁾				0.3	μA

(1) Assured by design. Not production tested.

6.19 ADC (Temperature and Cell Voltage) Characteristics

T_A = -40°C to 85°C, 2.4 V < V_{REG25} < 2.6 V; typical values at T_A = 25°C and V_{REG25} = 2.5 V (unless otherwise noted)

PARAMETER	TEST CONDITIONS	MIN	TYP	MAX	UNIT
V _{ADC_IN} Input voltage range (V _{BAT} channel)		V _{SS} - 0.125		5	V
	Input voltage range (other channels)	V _{SS} - 0.125		1	V
t _{ADC_CONV} Conversion time				125	ms
	Resolution		14	15	bits
V _{ADC_OS} Input offset			1		mV
Z _{ADC1} Effective input resistance (TS) ⁽¹⁾		55			MΩ
Z _{ADC2} Effective input resistance (BAT) ⁽¹⁾	Not measuring cell voltage	55			MΩ
	Measuring cell voltage		100		kΩ
I _{ADC_LKG} Input leakage current ⁽¹⁾				0.3	μA

(1) Assured by design. Not production tested.

6.20 Data Flash Memory Characteristics

$T_A = -40^{\circ}\text{C}$ to 85°C , $2.4\text{ V} < V_{\text{REG25}} < 2.6\text{ V}$; typical values at $T_A = 25^{\circ}\text{C}$ and $V_{\text{REG25}} = 2.5\text{ V}$ (unless otherwise noted)

PARAMETER	TEST CONDITIONS	MIN	TYP	MAX	UNIT
t_{DR}	Data retention ⁽¹⁾	10			years
	Flash programming write-cycles ⁽¹⁾	20,000			cycles
t_{WORDPROG}	Word programming time ⁽¹⁾			2	ms
I_{CCPROG}	Flash-write supply current ⁽¹⁾		5	10	mA

(1) Assured by design. Not production tested.

6.21 Timing Requirements

$T_A = -40^{\circ}\text{C}$ to 85°C , $2.4\text{ V} < V_{\text{REG25}} < 2.6\text{ V}$; typical values at $T_A = 25^{\circ}\text{C}$ and $V_{\text{REG25}} = 2.5\text{ V}$ (unless otherwise noted)

		MIN	NOM	MAX	UNIT
I²C-Compatible Interface Timing Characteristics (see Figure 1)					
t_{R}	SCL or SDA rise time			300	ns
t_{F}	SCL or SDA fall time			300	ns
$t_{\text{W(H)}}$	SCL pulse width (high)	600			ns
$t_{\text{W(L)}}$	SCL pulse width (low)	1.3			μs
$t_{\text{SU(STA)}}$	Setup for repeated start	600			ns
$t_{\text{d(STA)}}$	Start to first falling edge of SCL	600			ns
$t_{\text{SU(DAT)}}$	Data setup time	100			ns
$t_{\text{h(DAT)}}$	Data hold time	0			ns
$t_{\text{SU(STOP)}}$	Setup time for stop	600			ns
t_{BUF}	Bus free time between stop and start	66			μs
f_{SCL}	Clock frequency			400	kHz
HDQ Communication Timing Characteristics (see Figure 2)					
$t_{\text{(CYCH)}}$	Cycle time, host to fuel gauge	190			μs
$t_{\text{(CYCD)}}$	Cycle time, fuel gauge to host	190	205	250	μs
$t_{\text{(HW1)}}$	Host sends 1 to fuel gauge	0.5		50	μs
$t_{\text{(DW1)}}$	Fuel gauge sends 1 to host	32		50	μs
$t_{\text{(HW0)}}$	Host sends 0 to fuel gauge	86		145	μs
$t_{\text{(DW0)}}$	Fuel gauge sends 0 to host	80		145	μs
$t_{\text{(RSPS)}}$	Response time, fuel gauge to host	190		950	μs
$t_{\text{(B)}}$	Break time	190			μs
$t_{\text{(BR)}}$	Break recovery time	40			μs
$t_{\text{(RST)}}$	HDQ reset	1.8		2.2	s
$t_{\text{(RISE)}}$	HDQ line rise time to logic 1 (1.2 V)			950	ns

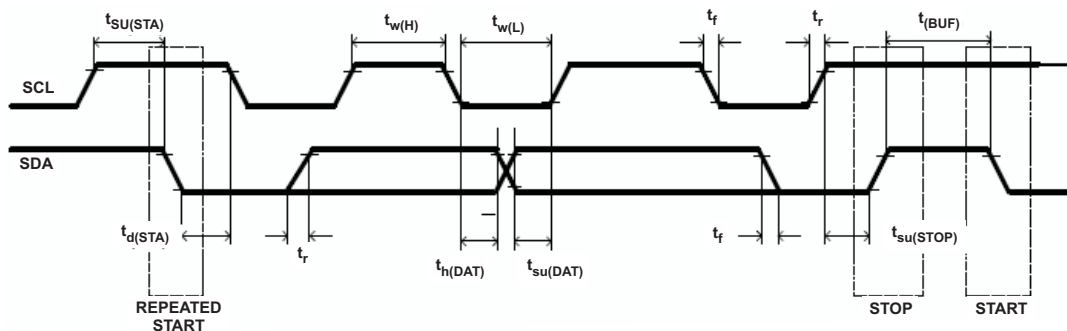
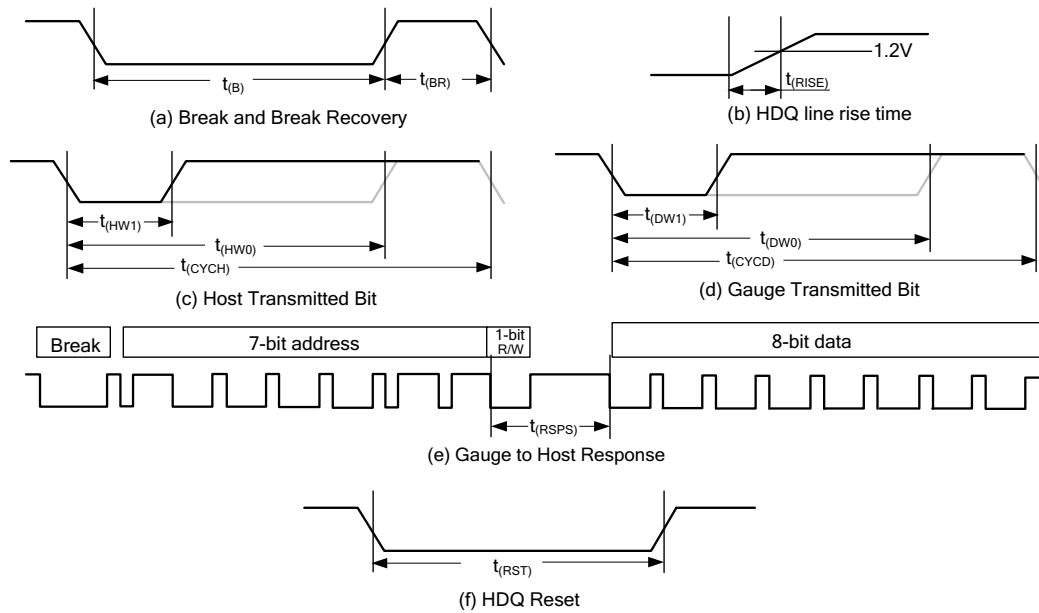

Figure 1. I²C-Compatible Interface Timing Diagrams



- a. HDQ Breaking
- b. Rise time of HDQ line
- c. HDQ Host to fuel gauge communication
- d. Fuel gauge to Host communication
- e. Fuel gauge to Host response format
- f. HDQ Host to fuel gauge reset

- A. HDQ Breaking
- B. Rise time of HDQ line
- C. HDQ Host to fuel gauge communication
- D. Fuel gauge to Host communication
- E. Fuel gauge to Host response format
- F. HDQ Host to fuel gauge reset

Figure 2. HDQ Communication Timing Diagrams

6.22 Typical Characteristics

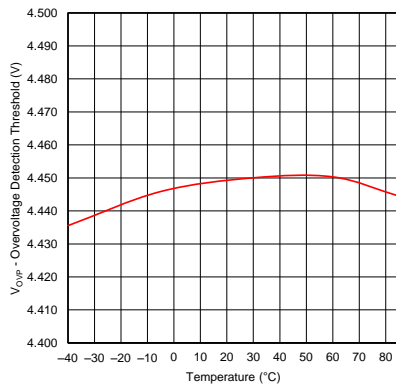
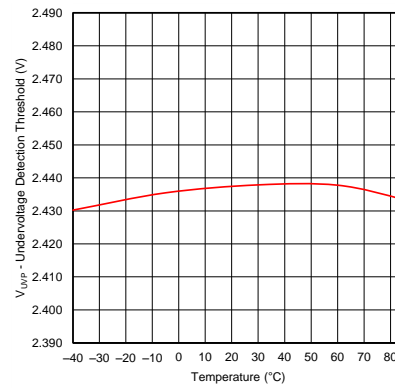
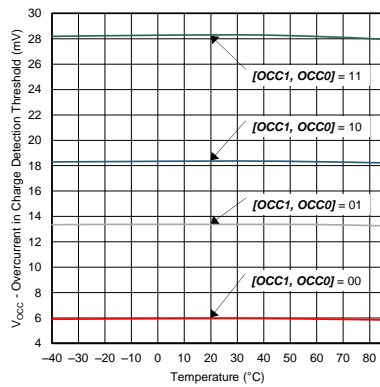

Figure 3. Overvoltage Detection Threshold vs Temperature



UVP threshold shown assumes an overvoltage setting of 4.450 V

Figure 4. Undervoltage Detection Threshold vs Temperature



OCC thresholds shown assume an overvoltage setting of 4.450 V

Figure 5. Overcurrent in Charge Detection Threshold vs Temperature

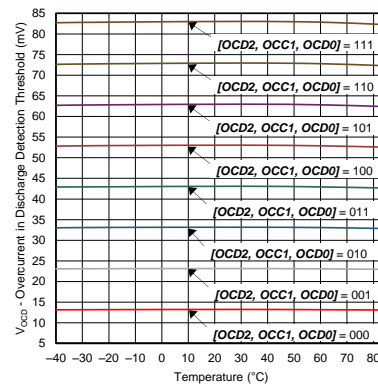

OCD thresholds shown assume an overvoltage setting of 4.450 V

Figure 6. Overcurrent in Discharge Detection Threshold vs Temperature

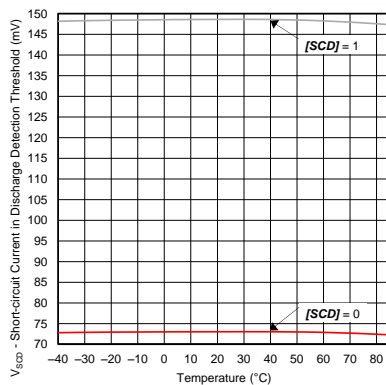

SCD thresholds shown assume an overvoltage setting of 4.450 V

Figure 7. Short-Circuit in Discharge Detection Threshold vs Temperature

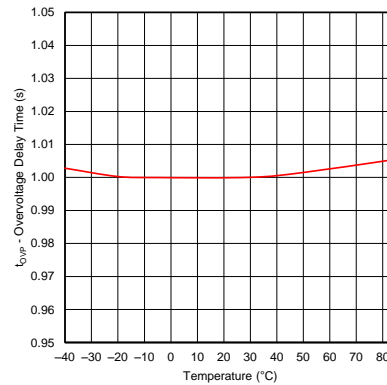

Figure 8. Overvoltage Delay Time

Typical Characteristics (continued)

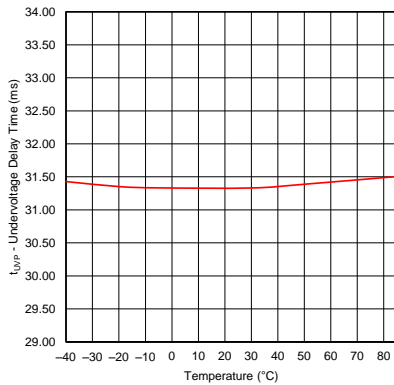

Figure 9. Undervoltage Delay Time

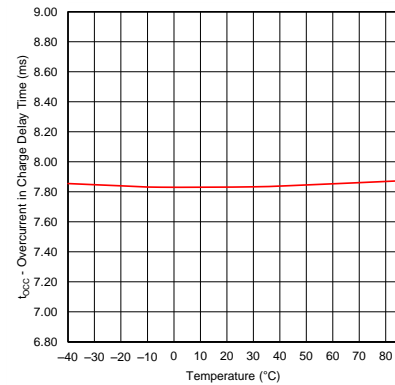

Figure 10. Overcurrent in Charge Delay Time vs Temperature

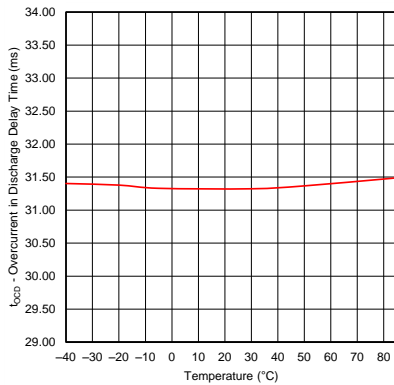

Figure 11. Overcurrent in Discharge Delay vs Temperature

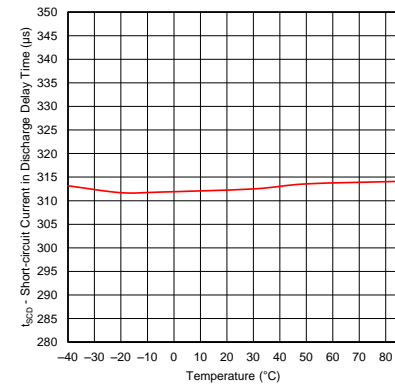
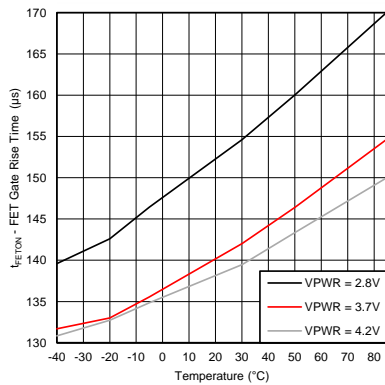
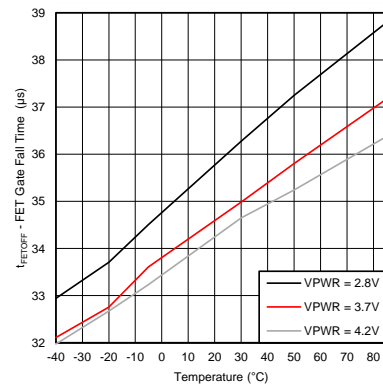

Figure 12. Short-Circuit in Discharge Delay vs Temperature



Performance with C_L = 4 nF

Figure 13. FET Gate Rise Time vs Temperature



Performance with C_L = 4 nF

Figure 14. FET Gate Fall Time vs Temperature

7 Detailed Description

7.1 Overview

The bq27742-G1 fuel gauge accurately predicts the battery capacity and other operational characteristics of a single Li-based rechargeable cell. It can be interrogated by a system processor to provide cell information, such as state-of-charge (SOC) and time-to-empty (TTE).

7.2 Functional Block Diagram

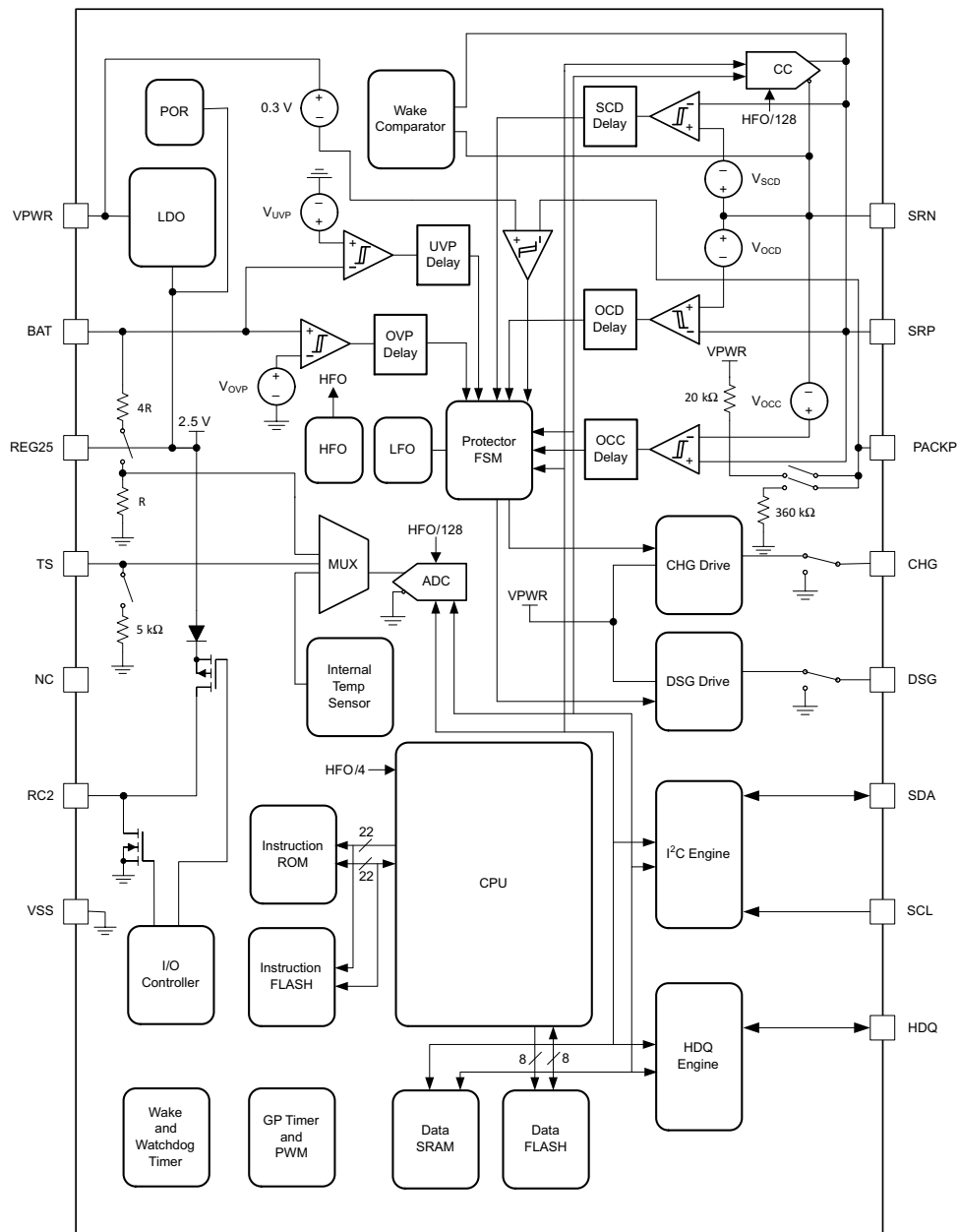

Copyright © 2017, Texas Instruments Incorporated

7.3 Feature Description

7.3.1 Configuration

Cell information is stored in the fuel gauge in non-volatile flash memory. Many of these data flash locations are accessible during application development. They cannot, generally, be accessed directly during end-equipment operation. Access to these locations is achieved by either use of the companion evaluation software, through individual commands, or through a sequence of data-flash-access commands. To access a desired data flash location, the correct data flash subclass and offset must be known.

The fuel gauge provides 64 bytes of user-programmable data flash memory, partitioned into two 32-byte blocks: **Manufacturer Info Block A** and **Manufacturer Info Block B**. This data space is accessed through a data flash interface.

7.3.2 Fuel Gauging

The key to the high-accuracy gas gauging prediction is Texas Instruments proprietary Impedance Track algorithm. This algorithm uses cell measurements, characteristics, and properties to create state-of-charge predictions that can achieve less than 1% error across a wide variety of operating conditions and over the lifetime of the battery.

See *Theory and Implementation of Impedance Track Battery Fuel-Gauging Algorithm Application Note (SLUA364)* for further details.

7.3.3 Power Modes

To minimize power consumption, the fuel gauge has different power modes: NORMAL, SLEEP, and FULLSLEEP. The fuel gauge passes automatically between these modes, depending upon the occurrence of specific events, though a system processor can initiate some of these modes directly.

7.3.3.1 NORMAL Mode

The fuel gauge is in NORMAL mode when not in any other power mode. During this mode, *AverageCurrent()*, *Voltage()*, and *Temperature()* measurements are taken, and the interface data set is updated. Decisions to change states are also made. This mode is exited by activating a different power mode.

Because the fuel gauge consumes the most power in NORMAL mode, the Impedance Track algorithm minimizes the time the fuel gauge remains in this mode.

7.3.3.2 SLEEP Mode

SLEEP mode performs *AverageCurrent()*, *Voltage()*, and *Temperature()* less frequently which results in reduced power consumption. SLEEP mode is entered automatically if the feature is enabled (**Pack Configuration [SLEEP] = 1**) and *AverageCurrent()* is below the programmable level **Sleep Current**. Once entry into SLEEP mode has been qualified, but prior to entering it, the fuel gauge performs an ADC autocalibration to minimize offset.

During the SLEEP mode, the fuel gauge periodically takes data measurements and updates its data set. However, a majority of its time is spent in an idle condition.

The fuel gauge exits SLEEP if any entry condition is broken, specifically when either:

- *AverageCurrent()* rises above **Sleep Current** or
- A current in excess of I_{WAKE} through R_{SENSE} is detected.

7.3.3.3 FULLSLEEP Mode

FULLSLEEP mode turns off the high-frequency oscillator and performs *AverageCurrent()*, *Voltage()*, and *Temperature()* less frequently which results in power consumption that is lower than that of the SLEEP mode.

FULLSLEEP mode can be enabled by two methods:

- Setting the **[FULLSLEEP]** bit in the Control Status register using the *FULL_SLEEP* subcommand and **Full Sleep Wait Time (FS Wait)** in data flash is set as 0.
- Setting the **Full Sleep Wait Time (FS Wait)** in data flash to a number larger than 0. This method is disabled when the **FS Wait** is set as 0.

Feature Description (continued)

FULLSLEEP mode is entered automatically when it is enabled by one of the methods above. When the first method is used, the gauge enters the FULLSLEEP mode when the fuel gauge is in SLEEP mode. When the second method is used, the FULLSLEEP mode is entered when the fuel gauge is in SLEEP mode and the timer counts down to 0.

The fuel gauge exits the FULLSLEEP mode when there is any communication activity. Therefore, the execution of SET_FULLSLEEP sets the **[FULLSLEEP]** bit. The FULLSLEEP mode can be verified by measuring the current consumption of the gauge.

During FULLSLEEP mode, the fuel gauge periodically takes data measurements and updates its data set. However, a majority of its time is spent in an idle condition.

The fuel gauge exits SLEEP if any entry condition is broken, specifically when either:

- *AverageCurrent()* rises above **Sleep Current**, or
- A current in excess of I_{WAKE} through R_{SENSE} is detected.

While in FULLSLEEP mode, the fuel gauge can suspend serial communications by as much as 4 ms by holding the comm line(s) low. This delay is necessary to correctly process host communication, because the fuel gauge processor is mostly halted in SLEEP mode.

7.3.4 Li-Ion Battery Protector Description

The battery protector controls two external high-side N-channel FETs in a back-to-back configuration for battery protection. The protector uses two voltage doublers to drive the CHG and DSG FETs on.

7.3.4.1 High-Side NFET Charge and Discharge FET Drive

These FETs are automatically turned off by the protector based on the detected hardware protection faults or by the fuel gauge based on detected firmware protection faults. This enables the gauge to be configured with effectively two levels of safety: the first level employing conservative protection settings to keep the cell within a safe operating area and the second level set to act as a fail-safe measure to prevent cell damage. Once the protection fault(s) is deemed to be cleared, the protector or fuel gauge will re-enable the applicable FET(s). Additionally, the FET drivers can be manually tested at production using the *FETTest(0x74/0x75)* extended command if needed.

7.3.4.2 Protector Configuration

The integrated Li-Ion hardware protector includes full programmability of its fault detection thresholds, eliminating the need to order several part variants to accommodate different system safety threshold needs. Configuration of the thresholds is provided in the form of data flash parameters, **Prot OV Config** and **Prot OC Config**, which are bit-mapped to two simple lookup tables that determine the protector safety thresholds. [Table 3](#) through [Table 6](#) detail the protection settings available for hardware overvoltage, overcurrent in charge, overcurrent in discharge, and short-circuit in discharge, respectively. An added degree of flexibility is made possible in combining the programmable thresholds with changes to the selected sense resistor value, enabling a wide variety of Li-Ion protection options in a single device.

Feature Description (continued)
Table 3. Hardware Overvoltage Protection Configuration

<i>Prot OV Config</i>			OVERVOLTAGE (V_{OVP}) SETTING
[OVP2]	[OVP1]	[OVP0]	
0	0	0	4.275 V
0	0	1	4.300 V
0	1	0	4.325 V
0	1	1	4.350 V
1	0	0	4.375 V
1	0	1	4.400 V
1	1	0	4.425 V
1	1	1	4.450 V (default)

Table 4. Hardware Overcurrent in Charge Configuration

<i>Prot OC Config</i>		OVERCURRENT IN CHARGE (V_{OCC}) SETTING
[OCC1]	[OCC0]	
0	0	6 mV
0	1	13 mV
1	0	18 mV (default)
1	1	28 mV

Table 5. Hardware Overcurrent in Discharge Configuration

<i>Prot OC Config</i>			OVERCURRENT IN DISCHARGE (V_{OCD}) SETTING
[OCD1]	[OCD0]	[OCD0]	
0	0	0	14 mV
0	0	1	24 mV
0	1	0	34 mV (default)
0	1	1	44 mV
1	0	0	53 mV
1	0	1	63 mV
1	1	0	73 mV
1	1	1	83 mV

Table 6. Hardware Short-Circuit in Discharge Configuration

<i>Prot OC Config</i>	SHORT-CIRCUIT IN DISCHARGE (V_{SCD}) SETTING
[SCD]	
0	73 mV (default)
1	148 mV

7.4 Device Functional Modes
7.4.1 Operating Modes

The battery protector has several operating modes depending on a variety of conditions. These modes are described below:

- NORMAL Mode
- OVERVOLTAGE Mode
- UNDERVOLTAGE Mode
- OVERCURRENT IN CHARGE Mode
- OVERCURRENT IN DISCHARGE and SHORT-CIRCUIT IN DISCHARGE Mode

Device Functional Modes (continued)

- SHUTDOWN WAIT Mode
 - ANALOG SHUTDOWN State
 - LOW VOLTAGE CHARGING State

The relationships among these modes are shown in Figure 15.

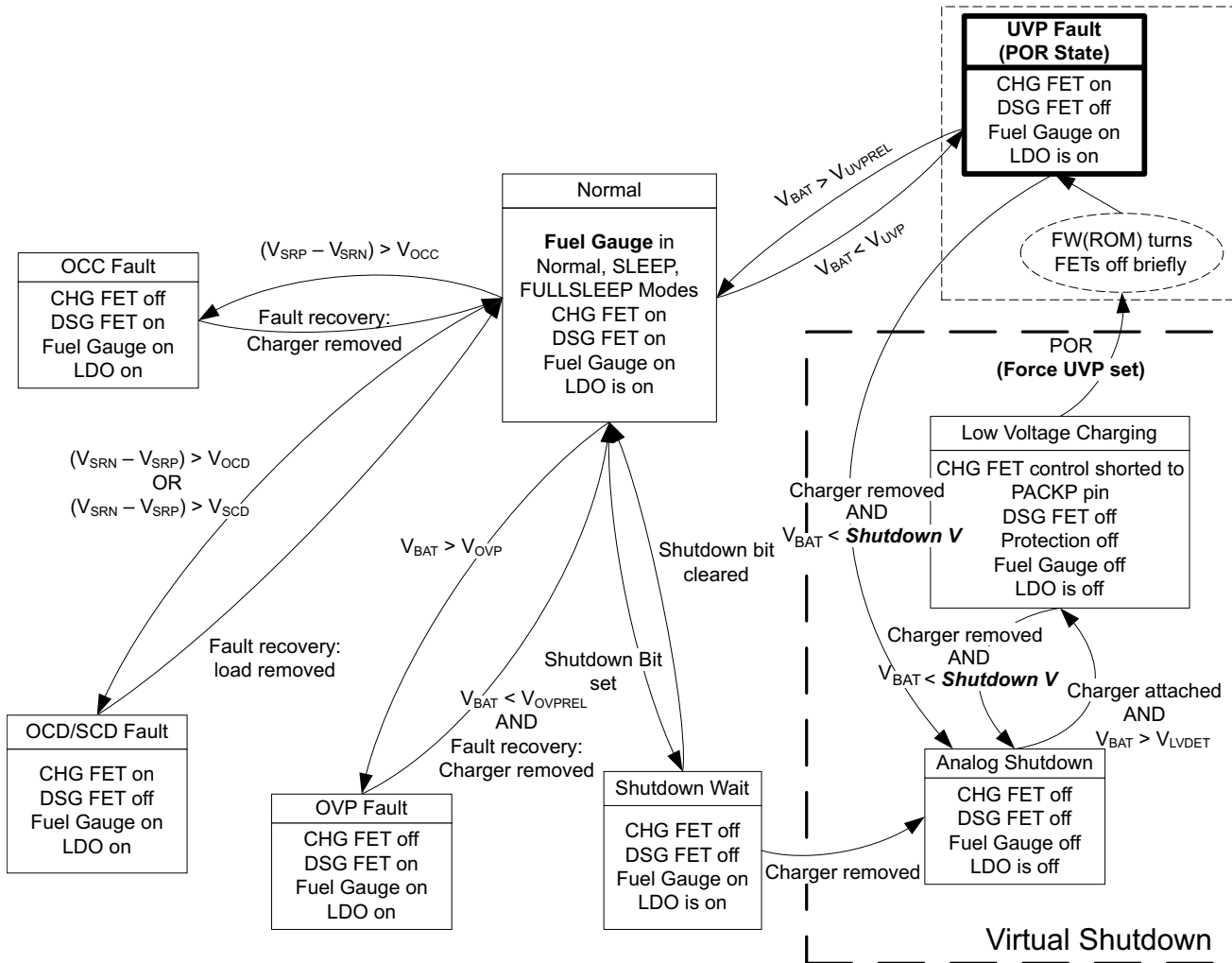

Figure 15. Operating Modes

7.4.1.1 NORMAL Mode

In this mode, the protector is fully powered and operational. Both CHG and DSG FETs are closed and the protector continuously checks for fault conditions.

FET enable override capability is available to the fuel gauge to force the CHG or DSG FET open based on firmware instruction. It is useful for firmware-defined safety features or other special functionality that requires one or both FETs to be opened based on specific conditions. It cannot, however, be used to enforce FET turn-on when the hardware protector is one of the protection fault modes, as the latter has ultimate authority over the FET drive control circuitry.

Firmware can also command the fuel gauge to go into SHUTDOWN mode based on a dedicated *Control()* subcommand from the host. In this case, firmware sets the shutdown bit, *[SHUTDOWN]*, to indicate intent to go into SHUTDOWN mode. The fuel gauge then transitions to SHUTDOWN WAIT mode and waits for charger removal prior to disabling the internal LDO and fully powering down the entire device.

Device Functional Modes (continued)

7.4.1.2 OVERVOLTAGE Mode

In this mode, an overvoltage protection (OVP) fault mode is entered when the voltage on the V_{BAT} pin continuously exceeds the V_{OVP} threshold for longer than the t_{OVP} delay time. At this point, the fuel gauge enables the fault recovery detection circuitry, which monitors the PACKP pin for charger removal. The OVP fault is cleared once the pack voltage drops below the cell voltage by more than 300 mV and the cell voltage drops below V_{OVPREL} , which causes the fuel gauge to transition to NORMAL mode.

7.4.1.3 UNDERVOLTAGE Mode

In this mode, an undervoltage protection (UVP) fault mode is entered when the voltage on the V_{BAT} pin continuously falls below the V_{UVP} threshold for longer than the t_{UVP} delay time. The fuel gauge then enables the charger attachment detection circuitry and, if no charger is found, sends the fuel gauge into ANALOG SHUTDOWN mode to minimize power consumption and avoid further discharge of the battery. The UVP fault is cleared once charger attachment is detected and the cell voltage rises above V_{UVPREL} , which causes the fuel gauge to transition to NORMAL mode.

The fuel gauge can enter this mode from LOW VOLTAGE CHARGING mode when the battery pack is being charged from a deeply discharged state or from NORMAL mode when the battery pack is being discharged past the UVP threshold.

7.4.1.4 OVERCURRENT IN CHARGE Mode

In this mode, an OVERCURRENT IN CHARGE (OCC) fault mode is entered when the voltage across the sense resistor continuously exceeds the V_{OCC} threshold for longer than the configured t_{OCC} delay time. Recovery occurs when the PACKP voltage drops to more than 300 mV below the cell voltage, indicating charger removal.

7.4.1.5 OVERCURRENT IN DISCHARGE and SHORT-CIRCUIT IN DISCHARGE Mode

In this mode, a short-circuit in discharge (SCD) or overcurrent in discharge (OCD) protection fault is detected when the voltage across the sense resistor continuously exceeds the V_{OCD} or V_{SCD} thresholds for longer than the t_{OCD} or t_{SCD} delay times. Recovery occurs when the PACKP voltage rises to within 300 mV of the cell voltage, indicating load removal.

7.4.1.6 SHUTDOWN WAIT Mode

A transition to this mode occurs when the host sends the SET_SHUTDOWN command and the fuel gauge subsequently initiated the shutdown sequence.

The shutdown sequence is as follows:

1. Open both CHG and DSG FETs.
2. Determine if any faults are set. If any faults are set, then go back to NORMAL mode.
3. Wait for charger removal. Once the charger is removed, turn off the LDO, which puts the fuel gauge into ANALOG SHUTDOWN mode.

7.4.1.6.1 ANALOG SHUTDOWN State

In this mode, the fuel gauge is completely powered down and no portions of the device are functional. Once the charger is connected, the fuel gauge will transition into either LOW VOLTAGE CHARGING mode (if below the power-on reset voltage) or NORMAL mode (if above the POR voltage and no faults are detected).

7.4.1.7 LOW VOLTAGE CHARGING State

In this mode, the fuel gauge shorts the CHG FET gate to PACKP pin if the cell voltage is above the V_{LVDET} threshold, allowing the battery to be trickle charged with the CHG FET biased in the ohmic region. If below the aforementioned threshold, low voltage charging is prohibited for safety reasons and the cell will likely be permanently unrecoverable due to being dangerously depleted.

7.4.2 Firmware Control of Protector

The firmware has control to open the CHG FET or DSG FET independently by overriding hardware control. However, it has no control to close the CHG FET or DSG FET and can only disable the FET override.

Device Functional Modes (continued)

7.4.3 OVERTEMPERATURE FAULT Mode

Gauging firmware monitors temperature every second and will open either the CHG FET if $Temperature() > OT\ Chg$ for **OT Chg Time** in CHARGING mode or open the DSG FET if $Temperature() > OT\ Dsg$ for **OT Dsg Time** in DISCHARGING mode. Gauge determination of charge or discharge mode is based on $Current() > Chg\ Current\ Threshold$ for **Quit Relax Time** or $Current() < Dsg\ Current\ Threshold$ for **Quit Relax Time**. Recovery from the given overtemperature fault occurs when $Temperature() < OT\ Chg\ Recovery$ or $< OT\ Dsg\ Recovery$, depending on if a charge overtemperature or discharge overtemperature fault is present.

7.4.4 Wake-Up Comparator

The wake-up comparator indicates a change in cell current while the fuel gauge is in SLEEP mode. Wake comparator threshold can be configured in firmware and set to the thresholds in [Table 7](#). An internal event is generated when the threshold is breached in either charge or discharge directions.

Table 7. I_{WAKE} Threshold Settings⁽¹⁾

RSNS1	RSNS0	IWAKE	Vth(SRP-SRN)
0	0	0	Disabled
0	0	1	Disabled
0	1	0	1.0 mV or –1.0 mV
0	1	1	2.2 mV or –2.2 mV
1	0	0	2.2 mV or –2.2 mV
1	0	1	4.6 mV or –4.6 mV
1	1	0	4.6 mV or –4.6 mV
1	1	1	9.8 mV or –9.8 mV

(1) The actual resistance value versus the setting of the sense resistor is not important just the actual voltage threshold when calculating the configuration. The voltage thresholds are typical values under room temperature.

7.5 Battery Parameter Measurements

7.5.1 Charge and Discharge Counting

The integrating delta-sigma ADC measures the charge or discharge flow of the battery by measuring the voltage drop across a small-value sense resistor between the SRP and SRN pins. The integrating ADC measures bipolar signals and detects charge activity when $V_{SR} = V_{SRP} - V_{SRN}$ is positive and discharge activity when $V_{SR} = V_{SRP} - V_{SRN}$ is negative. The fuel gauge continuously integrates the signal over time using an internal counter.

7.5.2 Voltage

The fuel gauge updates cell voltages at 1-second intervals when in NORMAL mode. The internal ADC of the fuel gauge measures the voltage, and scales and calibrates it appropriately. Voltage measurement is automatically compensated based on temperature. This data is also used to calculate the impedance of the cell for Impedance Track fuel gauging.

7.5.3 Current

The fuel gauge uses the SRP and SRN inputs to measure and calculate the battery charge and discharge current using a 5-mΩ to 20-mΩ typical sense resistor.

7.5.4 Auto-Calibration

The fuel gauge provides an auto-calibration feature to cancel the voltage offset error across SRN and SRP for maximum charge measurement accuracy. The fuel gauge performs auto-calibration before entering the SLEEP mode.

Battery Parameter Measurements (continued)

7.5.5 Temperature

The fuel gauge external temperature sensing is optimized with the use of a high-accuracy negative temperature coefficient (NTC) thermistor with $R_{25} = 10 \text{ k}\Omega \pm 1\%$ and $B_{25/85} = 3435 \text{ k}\Omega \pm 1\%$ (such as Semitec 103AT for measurement). The fuel gauge can also be configured to use its internal temperature sensor. The fuel gauge uses temperature to monitor the battery-pack environment, which is used for fuel gauging and cell protection functionality.

NOTE

Formatting Conventions in This Document:

Commands: *italics* with parentheses and no breaking spaces, for example, *RemainingCapacity()*

Data Flash: *italics*, **bold**, and breaking spaces; for example, **Design Capacity**

Register Bits and Flags: brackets only; for example, [TDA]

Data Flash Bits: *italic* and **bold**; for example, [**XYZ1**]

Modes and States: ALL CAPITALS; for example, UNSEALED mode

7.6 Communications

7.6.1 HDQ Single-Pin Serial Interface

The HDQ interface is an asynchronous return-to-one protocol where a processor sends the command code to the fuel gauge. With HDQ, the least significant bit (LSB) of a data byte (command) or word (data) is transmitted first. The DATA signal on pin 12 is open-drain and requires an external pullup resistor. The 8-bit command code consists of two fields: the 7-bit HDQ command code (bits 0 through 6) and the 1-bit RW field (MSB bit 7). The RW field directs the fuel gauge either to:

- Store the next 8 bits of data to a specified register, or
- Output 8 bits of data from the specified register

The HDQ peripheral can transmit and receive data as either an HDQ master or slave.

HDQ serial communication is normally initiated by the host processor sending a break command to the fuel gauge. A break is detected when the DATA pin is driven to a logic low state for a time $t_{(B)}$ or greater. The DATA pin then is returned to its normal ready logic high state for a time $t_{(BR)}$. The fuel gauge is now ready to receive information from the host processor.

The fuel gauge is shipped in the I²C mode. TI provides tools to enable the HDQ peripheral.

7.6.2 I²C Interface

The fuel gauge supports the standard I²C read, incremental read, one-byte write quick read, and functions. The 7-bit device address (ADDR) is the most significant 7 bits of the hex address and is fixed as 1010101. The 8-bit device address is therefore 0xAA or 0xAB for write or read, respectively.

Communications (continued)

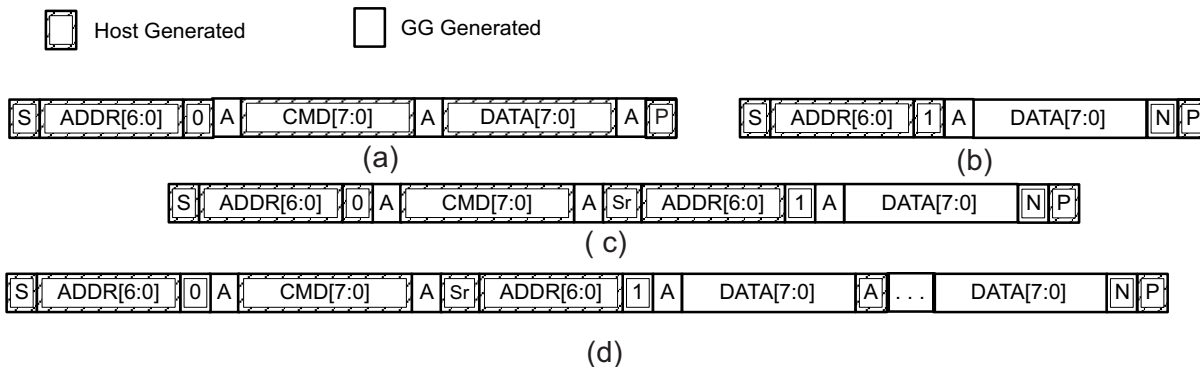

A. 1-byte write; b. Quick read; c. 1-byte read; Incremental read (S = Start, Sr = Repeated Start, A = Acknowledge, N = No Acknowledge, and P = Stop)

Figure 16. Supported I²C Formats

The quick read returns data at the address indicated by the address pointer. The address pointer, a register internal to the I²C communication engine, increments whenever data is acknowledged by the fuel gauge or the I²C master. Quick writes function in the same manner and are a convenient means of sending multiple bytes to consecutive command locations (such as two-byte commands that require two bytes of data).

Attempt to write a read-only address (NACK after data sent by master):

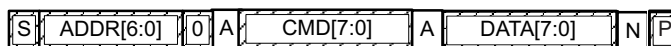

Attempt to read an address above 0x7F (NACK command):



Attempt at incremental writes (NACK all extra data bytes sent):

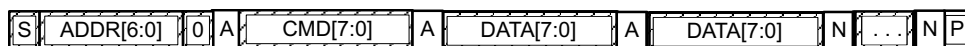

Incremental read at the maximum allowed read address:

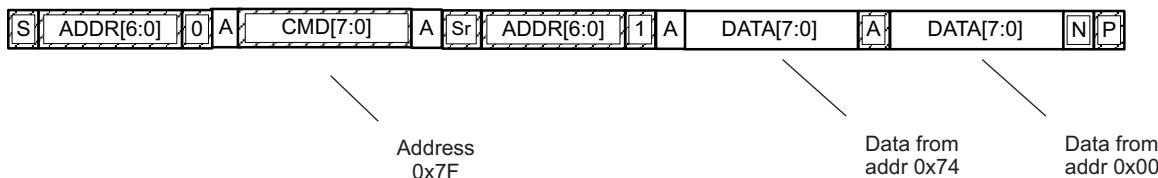

Figure 17. I²C Interfaces

The I²C engine releases both SDA and SCL if the I²C bus is held low for $t_{(BUSERR)}$. If the fuel gauge was holding the lines, releasing them frees the master to drive the lines. If an external condition is holding either of the lines low, the I²C engine enters the low-power SLEEP mode.

7.6.2.1 I²C Time Out

The I²C engine releases both SDA and SCL lines if the I²C bus is held low for about 2 seconds. If the fuel gauge was holding the lines, releasing them frees the master to drive the lines.

Communications (continued)

7.6.2.2 I²C Command Waiting Time

To ensure the correct results of a command with the 400-kHz I²C operation, a proper waiting time must be added between issuing a command and reading the results. For subcommands, the following diagram shows the waiting time required between issuing the control command and reading the status with the exception of the checksum command. A 100-ms waiting time is required between the checksum command and reading the result. For read-write standard commands, a minimum of 2 seconds is required to get the result updated. For read-only standard commands, there is no waiting time required, but the host must not issue any standard command more than two times per second. Otherwise, the gauge could result in a reset issue due to the expiration of the watchdog timer.

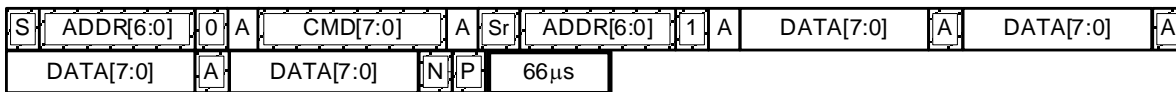
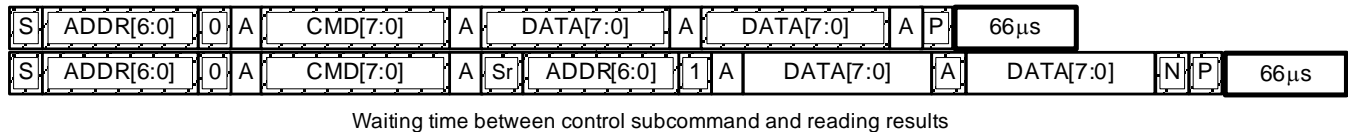

Figure 18. I²C Command Waiting Time

The I²C clock stretch could happen in a typical application. A maximum 80-ms clock stretch could be observed during the flash updates. There is up to a 270-ms clock stretch after the OCV command is issued.

7.7 Standard Data Commands

The fuel gauge uses a series of 2-byte standard commands to enable system reading and writing of battery information. Each standard command has an associated command-code pair, as indicated in [Table 8](#). Each protocol has specific means to access the data at each Command Code. Data RAM is updated and read by the gauge only once per second. Standard commands are accessible in NORMAL operation mode.

Table 8. Standard Commands

COMMAND NAME	COMMAND CODE	UNIT	SEALED ACCESS
<i>Control()</i>	0x00 and 0x01	—	RW
<i>AtRate()</i>	0x02 and 0x03	mA	RW
<i>UnfilteredSOC()</i>	0x04 and 0x05	%	R
<i>Temperature()</i>	0x06 and 0x07	0.1°K	R
<i>Voltage()</i>	0x08 and 0x09	mV	R
<i>Flags()</i>	0x0A and 0x0B	—	R
<i>NomAvailableCapacity()</i>	0x0C and 0x0D	mAh	R
<i>FullAvailableCapacity()</i>	0x0E and 0x0F	mAh	R
<i>RemainingCapacity()</i>	0x10 and 0x11	mAh	R
<i>FullChargeCapacity()</i>	0x12 and 0x13	mAh	R
<i>AverageCurrent()</i>	0x14 and 0x15	mA	R
<i>TimeToEmpty()</i>	0x16 and 0x17	min	R
<i>FilteredFCC()</i>	0x18 and 0x19	mAh	R
<i>SafetyStatus()</i>	0x1A and 0x1B	—	R
<i>UnfilteredFCC()</i>	0x1C and 0x1D	mAh	R
<i>Imax()</i>	0x1E and 0x1F	mA	R
<i>UnfilteredRM()</i>	0x20 and 0x21	mAh	R
<i>FilteredRM()</i>	0x22 and 0x23	mAh	R

Standard Data Commands (continued)
Table 8. Standard Commands (continued)

COMMAND NAME	COMMAND CODE	UNIT	SEALED ACCESS
<i>BTPSOC1Set()</i>	0x24 and 0x25	mAh	RW
<i>BTPSOC1Clear()</i>	0x26 and 0x27	mAh	RW
<i>InternalTemperature()</i>	0x28 and 0x29	0.1°K	R
<i>CycleCount()</i>	0x2A and 0x2B	Counts	R
<i>StateofCharge()</i>	0x2C and 0x2D	%	R
<i>StateofHealth()</i>	0x2E and 0x2F	%/num	R
<i>ChargingVoltage()</i>	0x30 and 0x31	mV	R
<i>ChargingCurrent()</i>	0x32 and 0x33	mA	R
<i>PassedCharge()</i>	0x34 and 0x35	mAh	R
<i>DOD0()</i>	0x36 and 0x37	hex	R
<i>SelfDischargeCurrent()</i>	0x38 and 0x39	mA	R

7.7.1 Control(): 0x00 and 0x01

Issuing a *Control()* command requires a subsequent 2-byte subcommand. These additional bytes specify the particular control function desired. The *Control()* command allows the system to control specific features of the fuel gauge during normal operation and additional features when the fuel gauge is in different access modes, as described in [Table 9](#).

Table 9. Control() Subcommands

SUBCOMMAND NAME	SUBCOMMAND CODE	SEALED ACCESS	DESCRIPTION
CONTROL_STATUS	0x0000	Yes	Reports the status of DF Checksum, Impedance Track, and so on.
DEVICE_TYPE	0x0001	Yes	Reports the device type of 0x0742 (indicating bq27742-G1).
FW_VERSION	0x0002	Yes	Reports the firmware version on the device type.
HW_VERSION	0x0003	Yes	Reports the hardware version on the device type.
PROTECTOR_VERSION	0x0004	Yes	Reports the hardware protector version on the device type.
RESET_DATA	0x0005	Yes	Returns reset data.
PREV_MACWRITE	0x0007	Yes	Returns previous <i>Control()</i> subcommand code.
CHEM_ID	0x0008	Yes	Reports the chemical identifier of the Impedance Track configuration.
BOARD_OFFSET	0x0009	No	Forces the device to measure and store the board offset.
CC_OFFSET	0x000A	No	Forces the device to measure the CC offset.
DF_VERSION	0x000C	Yes	Reports the data flash version of the device.
SET_FULLSLEEP	0x0010	Yes	Sets the <i>CONTROL_STATUS[FULLSLEEP]</i> bit to 1.
SET_SHUTDOWN	0x0013	Yes	Sets the <i>CONTROL_STATUS[SHUTDWN]</i> bit to 1.
CLEAR_SHUTDOWN	0x0014	Yes	Clears the <i>CONTROL_STATUS[SHUTDWN]</i> bit to 1.
STATIC_CHEM_CHKSUM	0x0017	Yes	Calculates chemistry checksum.
ALL_DF_CHKSUM	0x0018	Yes	Reports checksum for all data flash excluding device specific variables.
STATIC_DF_CHKSUM	0x0019	Yes	Reports checksum for static data flash excluding device specific variables.
PROTECTOR_CHKSUM	0x001A	Yes	Reports checksum for protector configuration data flash excluding device specific variables.
SEALED	0x0020	No	Places the fuel gauge in SEALED access mode.
IT_ENABLE	0x0021	No	Enables the Impedance Track algorithm.
IMAX_INT_CLEAR	0x0023	Yes	Clears an Imax interrupt that is currently asserted on the RC2 pin.
START_FET_TEST	0x0024	No	Starts FET Test based on data entered in <i>FETTest()</i> register. Sets and clears the <i>[FETTST]</i> bit in <i>CONTROL_STATUS</i> .
CAL_ENABLE	0x002D	No	Toggle CALIBRATION mode.
RESET	0x0041	No	Forces a full reset of the fuel gauge.

Table 9. Control() Subcommands (continued)

SUBCOMMAND NAME	SUBCOMMAND CODE	SEALED ACCESS	DESCRIPTION
EXIT_CAL	0x0080	No	Exit CALIBRATION mode.
ENTER_CAL	0x0081	No	Enter CALIBRATION mode.
OFFSET_CAL	0x0082	No	Reports internal CC offset in CALIBRATION mode.

7.8 Extended Data Commands

Extended commands offer additional functionality beyond the standard set of commands. They are used in the same manner; however unlike standard commands, extended commands are not limited to 2-byte words. The number of command bytes for a given extended command ranges in size from single to multiple bytes, as specified in [Table 10](#). For details on the SEALED and UNSEALED states, see the *Access Modes* section in the *bq27742-G1 Technical Reference Manual (SLUJAX0)*.

Table 10. Extended Commands

NAME	COMMAND CODE	UNIT	SEALED ACCESS ⁽¹⁾⁽²⁾	UNSEALED ACCESS ⁽¹⁾⁽²⁾
<i>PackConfiguration()</i>	0x3A and 0x3B	Hex	R	R
<i>DesignCapacity()</i>	0x3C and 0x3D	mAh	R	R
<i>DataFlashClass()</i> ⁽²⁾	0x3E	NA	NA	RW
<i>DataFlashBlock()</i> ⁽²⁾	0x3F	NA	RW	RW
<i>BlockData()/Authenticate()</i> ⁽³⁾	0x40 to 0x53	NA	RW	RW
<i>BlockData()/AuthenticateChecksum()</i> ⁽³⁾	0x54	NA	RW	RW
<i>BlockData()</i>	0x55 to 0x5F	NA	R	RW
<i>BlockDataChecksum()</i>	0x60	NA	RW	RW
<i>BlockDataControl()</i>	0x61	NA	NA	RW
<i>DODatEOC()</i>	0x62 and 0x63	NA	R	R
<i>Qstart()</i>	0x64 and 0x65	mAh	R	R
<i>FastQmax()</i>	0x66 and 0x67	mAh	R	R
Reserved	0x68 to 0x6C	NA	R	R
<i>ProtectorStatus()</i>	0x6D	Hex	R	R
Reserved	0x6E and 0x6F	NA	R	R
<i>SimultaneousCurrent()</i>	0x70 and 0x71	mA	R	R
Reserved	0x72 and 0x73	NA	R	R
<i>FETTest()</i>	0x74 and 0x75	Hex	R	RW
<i>AveragePower()</i>	0x76 and 0x77	mW or cW	R	R
<i>ProtectorState()</i>	0x78	Hex	R	R
AN_COUNTER	0x79			
AN_CURRENT_LSB	0x7A			
AN_CURRENT_MSB	0x7B			
AN_VCELL_LSB	0x7C			
AN_VCELL_MSB	0x7D			
AN_TEMP_LSB	0x7E			
AN_TEMP_MSB	0x7F			

(1) SEALED and UNSEALED states are entered via commands to *Control()* 0x00 and 0x01

(2) In SEALED mode, data flash cannot be accessed through commands 0x3E and 0x3F.

(3) The *BlockData()* command area shares functionality for accessing general data flash and for using Authentication. See *Authentication* in the *bq27742-G1 Technical Reference Manual (SLUJAX0)* for more details.

8 Application and Implementation

NOTE

Information in the following applications sections is not part of the TI component specification, and TI does not warrant its accuracy or completeness. TI's customers are responsible for determining suitability of components for their purposes. Customers should validate and test their design implementation to confirm system functionality.

8.1 Application Information

The bq27742-G1 is a single-cell fuel gauge with integrated Li-Ion protection circuitry for highly accurate detection of overvoltage, undervoltage, overcurrent in charge, overcurrent in discharge, and short-circuit in discharge fault conditions. If the detected fault continues to be present for a specific delay time (preconfigured in the device), the protection front-end will disable the applicable charge pump circuit, resulting in opening of the FET until the provoking safety condition resolves. The integrated 16-bit delta-sigma converters provide accurate, high precision measurements for voltage, current, and temperature in order to accomplish effective battery monitoring, protection, and gauging. To allow for optimal performance in the end application, special considerations must be taken to ensure minimization of measurement error through proper printed circuit board (PCB) board layout and correct configuration of battery characteristics in the fuel gauge data flash. Such requirements are detailed in [Design Requirements](#).

8.2 Typical Applications

8.2.1 Pack-Side, Single-Cell Li-Ion Fuel Gauge and Protector

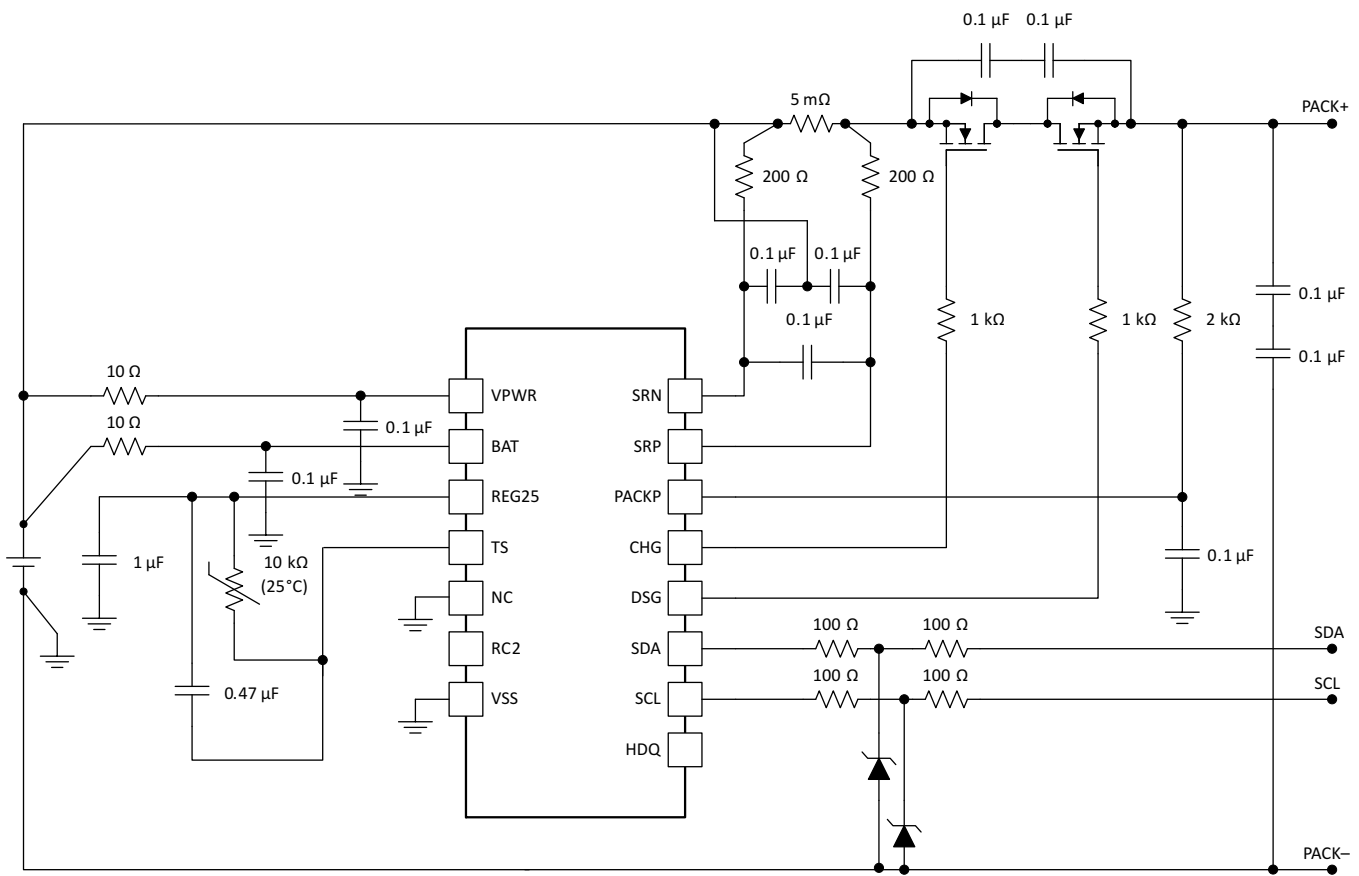

Copyright © 2017, Texas Instruments Incorporated

Figure 19. I²C Mode Schematic

Typical Applications (continued)

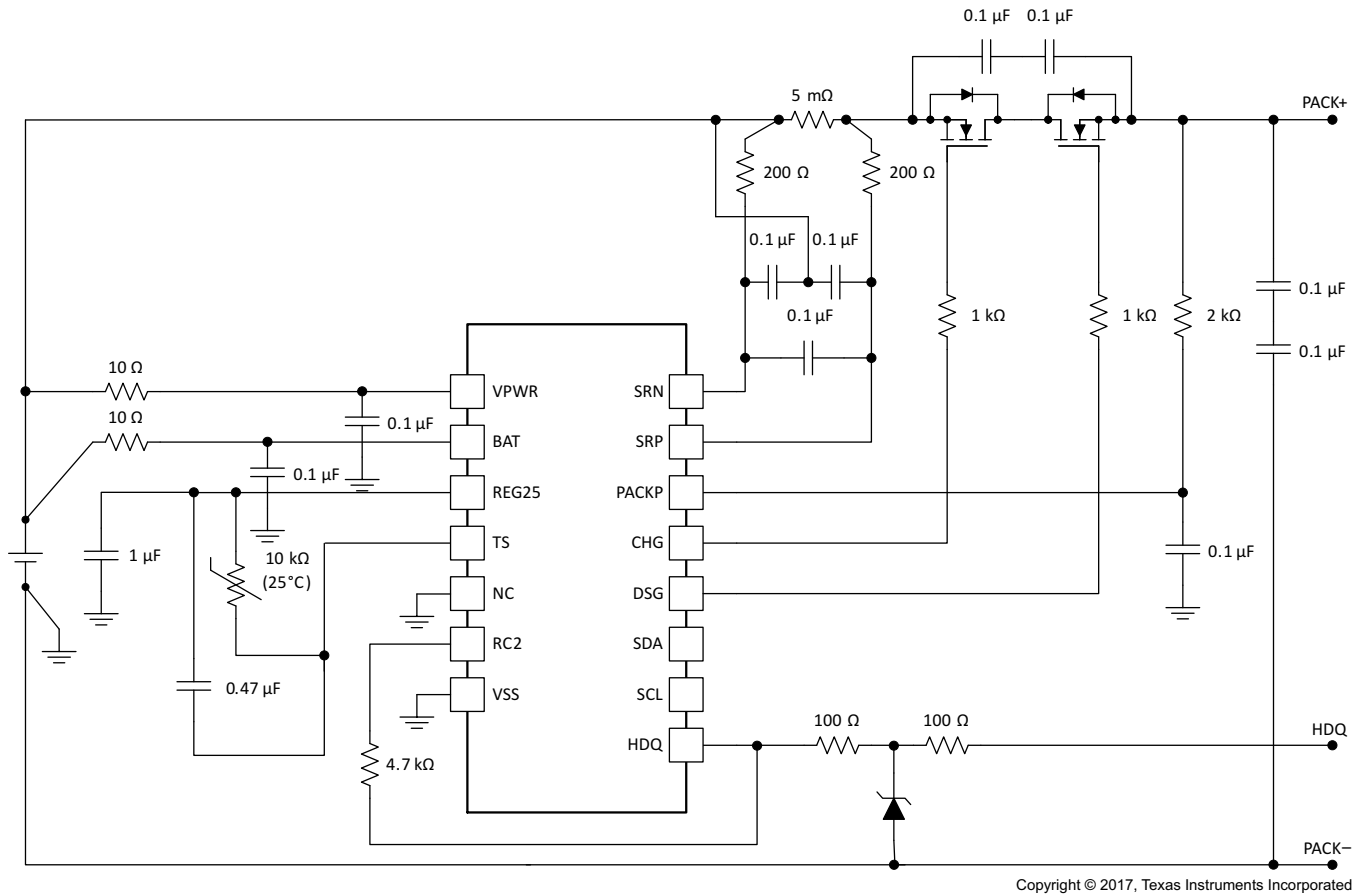

Figure 20. HDQ Mode Schematic

8.2.2 Design Requirements

Several key parameters must be updated to align with a given application's battery characteristics. For highest accuracy gauging, it is important to follow-up this initial configuration with a learning cycle to optimize resistance and maximum chemical capacity (Qmax) values prior to sealing and shipping packs to the field. Successful and accurate configuration of the fuel gauge for a target application can be used as the basis for creating a "golden" gas gauge (.GG) file that can be written to all production packs, assuming identical pack design and Li-Ion cell origin (chemistry, lot, and so on). Calibration data can be included as part of this golden GG file to cut down on battery pack production time. If going this route, it is recommended to average the calibration data from a large sample size and use these in the golden file. Ideally, it is recommended to calibrate all packs individually as this will lead to the highest performance and lowest measurement error in the end application on a per-pack basis. In addition, the integrated protection functionality should be correctly configured to ensure activation based on the fault protection needs of the target pack design, or else accidental trip could be possible if using defaults. [Table 11, Key Data Flash Parameters for Configuration](#), shows the items that should be configured to achieve reliable protection and accurate gauging with minimal initial configuration.

Table 11. Key Data Flash Parameters for Configuration

NAME	DEFAULT	UNIT	RECOMMENDED SETTING
Design Capacity	1000	mAh	Set based on the nominal pack capacity as interpreted from cell manufacturer's datasheet. If multiple parallel cells are used, should be set to N * Cell Capacity.
Design Energy	3800	mWh	Set based on the nominal pack energy (nominal cell voltage * nominal cell capacity) as interpreted from the cell manufacturer's datasheet. If multiple parallel cells are used, should be set to N * Cell Energy.

Typical Applications (continued)
Table 11. Key Data Flash Parameters for Configuration (continued)

NAME	DEFAULT	UNIT	RECOMMENDED SETTING
Design Energy Scale	1	—	Set to 10 to convert all power values to cWh or to 1 for mWh. Design Energy is divided by this value.
Reserve Capacity	0	mAh	Set to desired runtime remaining (in seconds/3600) * typical applied load between reporting 0% SOC and reaching Terminate Voltage , if needed.
Design Voltage	3800	mV	Set to nominal cell voltage per manufacturer datasheet.
Cycle Count Threshold	900	mAh	Set to 90% of configured Design Capacity
Device Chemistry	0354	hex	Should be configured using TI-supplied Battery Management Studio software. Default open-circuit voltage and resistance tables are also updated in conjunction with this step. Do not attempt to manually update reported Device Chemistry as this does not change all chemistry information! Always update chemistry using the appropriate software tool (that is, BMS).
Load Mode	1	—	Set to applicable load model, 0 for constant current or 1 for constant power.
Load Select	1	—	Set to load profile which most closely matches typical system load.
Qmax Cell 0	1000	mAh	Set to initial configured value for Design Capacity. The gauge will update this parameter automatically after the optimization cycle and for every regular Qmax update thereafter.
V at Chg Term	4350	mV	Set to nominal cell voltage for a fully charged cell. The gauge will update this parameter automatically each time full charge termination is detected.
Terminate Voltage	3000	mV	Set to empty point reference of battery based on system needs. Typical is between 3000 and 3200 mV.
Ra Max Delta	43	mΩ	Set to 15% of Cell0 R _a resistance after an optimization cycle is completed.
Charging Voltage	4350	mV	Set based on nominal charge voltage for the battery in normal conditions (25°C, for example). Used as the reference point for offsetting by Taper Voltage for full charge termination detection.
Taper Current	100	mA	Set to the nominal taper current of the charger + taper current tolerance to ensure that the gauge will reliably detect charge termination.
Taper Voltage	100	mV	Sets the voltage window for qualifying full charge termination. Can be set tighter to avoid or wider to ensure possibility of reporting 100% SOC in outer JEITA temperature ranges that use derated charging voltage.
Dsg Current Threshold	60	mA	Sets threshold for gauge detecting battery discharge. Should be set lower than minimal system load expected in the application and higher than Quit Current .
Chg Current Threshold	75	mA	Sets the threshold for detecting battery charge. Can be set higher or lower depending on typical trickle charge current used. Also should be set higher than Quit Current .
Quit Current	40	mA	Sets threshold for gauge detecting battery relaxation. Can be set higher or lower depending on typical standby current and exhibited in the end system.
Avg I Last Run	-299	mA	Current profile used in capacity simulations at onset of discharge or at all times if Load Select = 0. Should be set to nominal system load. Is automatically updated by the gauge every cycle.
Avg P Last Run	-1131	mW	Power profile used in capacity simulations at onset of discharge or at all times if Load Select = 0. Should be set to nominal system power. Is automatically updated by the gauge every cycle.
Sleep Current	15	mA	Sets the threshold at which the fuel gauge enters SLEEP Mode. Take care in setting above typical standby currents else entry to SLEEP may be unintentionally blocked.
Shutdown V	0	mV	If auto-shutdown of fuel gauge is required prior to protect against accidental discharge to undervoltage condition, set this to desired voltage threshold for completely powering down the fuel gauge. Recovery occurs when a charger is connected.
T1 Temp	0	°C	Sets the boundary between charging inhibit/suspend and charging with T1-T2 parameters. Defaults set based on recommended values from JEITA standard.
T2 Temp	10	°C	Sets the boundary between charging with T1-T2 or T2-T3 parameters. Defaults set based on recommended values from JEITA standard.
T3 Temp	45	°C	Sets the boundary between charging with T2-T3 or T3-T4 parameters. Defaults set based on recommended values from JEITA standard.

Typical Applications (continued)
Table 11. Key Data Flash Parameters for Configuration (continued)

NAME	DEFAULT	UNIT	RECOMMENDED SETTING
T4 Temp	50	°C	Sets the boundary between charging with T4-T5 or T4-T5 parameters. Also serves as charge inhibit boundary if initiating new charging event. Defaults set based on recommended values from JEITA standard.
T5 Temp	60	°C	Sets the boundary between charging suspend and charging with T4-T5 parameters. Refer to JEITA standard for compliance.
Temp Hys	1	°C	Adds temperature hysteresis for boundary crossings to avoid oscillation if temperature is changing by a degree or so on a given boundary.
T1-T2 Chg Voltage	4350	mV	Sets reported charge voltage when inside of T1 Temp and T2 Temp range. Defaults set based on recommended values from JEITA standard.
T2-T3 Chg Voltage	4350	mV	Sets reported charge voltage when inside of T2 Temp and T3 Temp range. Defaults set based on recommended values from JEITA standard.
T3-T4 Chg Voltage	4300	mV	Sets reported charge voltage when inside of T3 Temp and T4 Temp range. Defaults set based on recommended values from JEITA standard.
T4-T5 Chg Voltage	4250	mV	Sets reported charge voltage when inside of T4 Temp and T5 Temp range. Defaults set based on recommended values from JEITA standard.
T1-T2 Chg Current	50	%	Sets reported charge current when inside of T1 Temp and T2 Temp range. Defaults set based on recommended values from JEITA standard.
T2-T3 Chg Current	80	%	Sets reported charge current when inside of T2 Temp and T3 Temp range. Defaults set based on recommended values from JEITA standard.
T3-T4 Chg Current	80	%	Sets reported charge current when inside of T3 Temp and T4 Temp range. Defaults set based on recommended values from JEITA standard.
T4-T5 Chg Current	80	%	Sets reported charge current when inside of T4 Temp and T5 Temp range. Defaults set based on recommended values from JEITA standard.
OV Prot Threshold	4390	mV	Set to maximum allowable cell voltage due to overcharge in normal operation.
OV Prot Delay	1	s	Set to required OVP duration prior to fault detection and FET disable. Setting of 0 disables firmware-based OVP feature. Default of 1s is recommended.
OV Prot Recovery	4290	mV	Set to desired OVP recovery threshold. 100 to 200 mV below OVP trip threshold is common.
OV Prot Threshold	2800	mV	Set to minimum allowable cell voltage due to overdischarge in normal operation.
OV Prot Delay	1	s	Set to required UVP duration prior to fault detection and FET disable. Setting of 0 disables firmware-based UVP feature. Default of 1s is recommended.
OV Prot Recovery	2900	mV	Set to desired UVP recovery threshold. 100 to 200 mV above UVP trip threshold is common.
Body Diode Current Threshold	60	mA	Varies based on FET selection. Use the max DC current for the forward-biased body diode from the FET datasheet and derate based on the operating temperature range to arrive at the minimum current value (and add some margin) that the fuel gauge should use to re-enable FET when disabled during a fault condition.
OT Chg	55.0	°C	Set to desired temperature at which charging is prohibited to prevent cell damage due to excessive ambient temperature.
OT Chg Time	5	s	Set to desired time before CHG FET is disabled based on overtemperature. Since temperature changes much more slowly than other fault conditions, the default setting is sufficient for most application.
OT Chg Recovery	50.0	°C	Set to the temperature threshold at which charging is no longer prohibited.
OT Dsg	60.0	°C	Set to desired temperature at which discharging is prohibited to prevent cell damage due to excessive ambient temperature.
OT Dsg Time	5	s	Set to desired time before DSG FET is disabled based on overtemperature. Since temperature changes much more slowly than other fault conditions, the default setting is sufficient for most application.
OT Dsg Recovery	55.0	°C	Set to the temperature threshold at which cell discharging is no longer prohibited.
Prot OC Config	0A	hex	Set based on required trip thresholds for overcurrent in charge, overcurrent in discharge, and short-circuit in discharge. When setting this parameter, be sure to account for charger tolerance and maximum load spikes expected in the end system to avoid accidental trip of these fault conditions

Typical Applications (continued)

Table 11. Key Data Flash Parameters for Configuration (continued)

NAME	DEFAULT	UNIT	RECOMMENDED SETTING
Prot OV Config	07	hex	Set to maximum tolerable cell voltage before cell is permanently damaged. Serves as a second level OVP protection mechanism.
Prot Checksum	11	hex	Set to sum of Prot OC Config and Prot OV Config . Improper setting will cause FETs to open and warning flag assertion in <i>SafetyStatus()</i> , until corrected.
CC Gain	5	mΩ	Calibrate this parameter using TI-supplied BMS software and calibration procedure in the TRM. Determines conversion of coulomb counter measured sense resistor voltage to current.
CC Delta	5.074	mΩ	Calibrate this parameter using TI-supplied BMS software and calibration procedure in the TRM. Determines conversion of coulomb counter measured sense resistor voltage to passed charge.
CC Offset	6.874	mA	Calibrate this parameter using TI-supplied BMS software and calibration procedure in the TRM. Determines native offset of coulomb counter hardware that should be removed from conversions.
Board Offset	0.66	uA	Calibrate this parameter using TI-supplied BMS software and calibration procedure in the TRM. Determines native offset of the printed circuit board parasitics that should be removed from conversions.
Pack V Offset	0	mV	Calibrate this parameter using TI-supplied BMS software and calibration procedure in the TRM. Determines voltage offset between cell tab and ADC input node to incorporate back into or remove from measurement, depending on polarity.

8.2.3 Detailed Design Procedure

8.2.3.1 BAT Voltage Sense Input

A ceramic capacitor at the input to the BAT pin is used to bypass AC voltage ripple to ground, greatly reducing its influence on battery voltage measurements. It proves most effective in applications with load profiles that exhibit high frequency current pulses (that is, cell phones) but is recommended for use in all applications to reduce noise on this sensitive high impedance measurement node.

The series resistor between the battery and the BAT input is used to limit current that could be conducted through the chip-scale package's solder bumps in the event of an accidental short during the board assembly process. The resistor is not likely to survive a sustained short condition (depends on power rating), however, it sacrifices the much cheaper resistor component over suffering damage to the fuel gauge die itself.

8.2.3.2 SRP and SRN Current Sense Inputs

The filter network at the input to the coulomb counter is intended to improve differential mode rejection of voltage measured across the sense resistor. These components should be placed as close as possible to the coulomb counter inputs and the routing of the differential traces length-matched in order to best minimize impedance mismatch-induced measurement errors. The single-ended ceramic capacitors should be tied to the battery voltage node (preferably to a large copper pour connected to the SRN side of the sense resistor) in order to further improve common-mode noise rejection. The series resistors between the CC inputs and the sense resistor should be at least 200 Ω in order to mitigate SCR-induced latch-up due to possible ESD events.

8.2.3.3 Sense Resistor Selection

Any variation encountered in the resistance present between the SRP and SRN pins of the fuel gauge will affect the resulting differential voltage, and derived current, it senses. As such, it is recommended to select a sense resistor with minimal tolerance and temperature coefficient of resistance (TCR) characteristics. The standard recommendation based on best compromise between performance and price is a 1% tolerance, 50-ppm drift sense resistor with a 1-W power rating.

8.2.3.4 TS Temperature Sense Input

Similar to the BAT pin, a ceramic decoupling capacitor for the TS pin is used to bypass AC voltage ripple away from the high-impedance ADC input, minimizing measurement error. Another helpful advantage is that the capacitor provides additional ESD protection since most thermistors are handled and manually soldered to the PCB as a separate step in the factory production flow. As before, it should be placed as close as possible to the respective input pin for optimal filtering performance.

8.2.3.5 Thermistor Selection

The fuel gauge temperature sensing circuitry is designed to work with a negative temperature coefficient-type (NTC) thermistor with a characteristic 10-k Ω resistance at room temperature (25°C). The default curve-fitting coefficients configured in the fuel gauge specifically assume a 103AT-2 type thermistor profile and so that is the default recommendation for thermistor selection purposes. Moving to a separate thermistor resistance profile (for example, JT-2 or others) requires an update to the default thermistor coefficients in data flash to ensure highest accuracy temperature measurement performance.

8.2.3.6 VPWR Power Supply Input Filtering

A ceramic capacitor is placed at the input to the fuel gauge's internal LDO in order to increase power supply rejection (PSR) and improve effective line regulation. It ensures that voltage ripple is rejected to ground instead of coupling into the device's internal supply rails.

8.2.3.7 REG25 LDO Output Filtering

A ceramic capacitor is also needed at the output of the internal LDO in order to provide a current reservoir for fuel gauge load peaks during high peripheral utilization. It acts to stabilize the regulator output and reduce core voltage ripple inside of the device.

8.2.3.8 Communication Interface Lines

A protection network composed of resistors and zener diodes is recommended on each of the serial communication inputs to protect the fuel gauge from dangerous ESD transients. The Zener should be selected to break down at a voltage larger than the typical pullup voltage for these lines but less than the internal diode clamp breakdown voltage of the device inputs (~6 V). A zener voltage of 5.6 V is typically recommended. The series resistors are used to limit the current into the Zener diode and prevent component destruction due to thermal strain once it goes into breakdown. 100 Ω is typically recommended for these resistance values.

For HDQ-based designs, a pullup resistor is normally designed in on the battery pack PCB and can be connected to the RC2 input since a 1.8-V pullup voltage is readily available and provided by the fuel gauge.

8.2.3.9 PACKP Voltage Sense Input

Inclusion of a 2-k Ω series resistor on the PACKP input allows it to tolerate a charger overvoltage event up to 28 V without device damage. The resistor also protects the device in the event of a reverse polarity charger input, since the substrate diode will be forward biased and attempt to conduct charger current through the fuel gauge (as well as the high FETs). An external reverse charger input FET clamp can be added to short the DSG FET gate to its source terminal, forcing the conduction channel off when negative voltage is present at PACK+ input to the battery pack and preventing large battery discharge currents. A ceramic capacitor connected at the PACKP pin helps to filter voltage into the comparator sense lines used for checking charger and load presence. In addition, in the Low Voltage Charging State, the minimal circuit elements that are operational are powered from this input pin and require a stable supply.

8.2.3.10 CHG and DSG Charge Pump Voltage Outputs

The series resistors used at the DSG and CHG output pins serve to protect them from damaging ESD events or breakdown conditions, allowing the resistors to be sacrificed in place of the fuel gauge itself. An added bonus is that they also help to limit in-rush currents due to use of FETs with large gate capacitance, allowing smooth ramp of power-path connection turn-on to the system.

8.2.3.11 NFET Selection

The choice in NFETs for a single-cell battery pack design will depend on a variety of factors including package type, size, and device cost as well as performance metrics such as drain-to-source resistance ($r_{DS(on)}$), gate capacitance, maximum current and power handling, and similar. At a bare minimum, it is recommended that the selected FETs have a drain-to-source voltage (V_{DS}) and gate-to-source (V_{GS}) voltage tolerance of 12 V. Some FETs can be designed to handle as much as 24 V between the drain and source terminals and this would provide an increased safety margin for the pack design. Further, the DC current rating should be high enough to safely handle sustained current in charge or discharge direction just below the maximum threshold tolerances of the configured OCC and OCD protections and the lowest possible sense resistance value based on tolerance and TCR considerations, or vice-versa. This ensures that there is sufficient power dissipation margin given a worst case scenario for the fault detections. In addition, striving for minimal FET resistance at the expected gate bias as well as lowest gate capacitance will help reduce conduction losses and increase power efficiency as well as achieve faster turn-on and turn-off times for the FETs. Many of these FETs are now offered as dual, back-back NFETs in wafer-chip scale (WCSP) packaging, decreasing both BOM count and shrinking necessary board real estate to accommodate the components. Last, one should always refer to the safe operating area (SOA) curves of the target FETs to ensure that the boundaries are never violated based on all possible load conditions in the end application. The CSD83325L is an excellent example of a FET solution that meets all of the aforementioned criteria, offering $r_{DS(on)}$ of 10.3 m Ω and V_{DS} of 12 V with back-to-back NFETs in a chip-scale package, a perfect fit for battery pack designs.

8.2.3.12 Additional ESD Protection Components

The additional capacitors placed across the CHG and DSF FET source pins as well as between PACK+ and ground help to bolster and greatly improve the ESD robustness of the pack design. The former components shunt damaging transients around the FETs and the latter components attempt to bypass such pulses to PACK– before they couple further into the battery pack PCB. Two series capacitors are used for each of these protection areas to prevent a battery short in the event of a single capacitor failure.

8.2.4 Application Curves

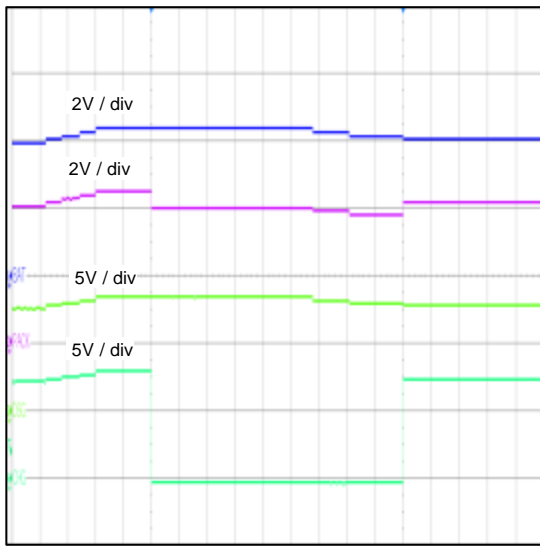

500ms / div

Figure 21. Overvoltage Protection Set and Clear

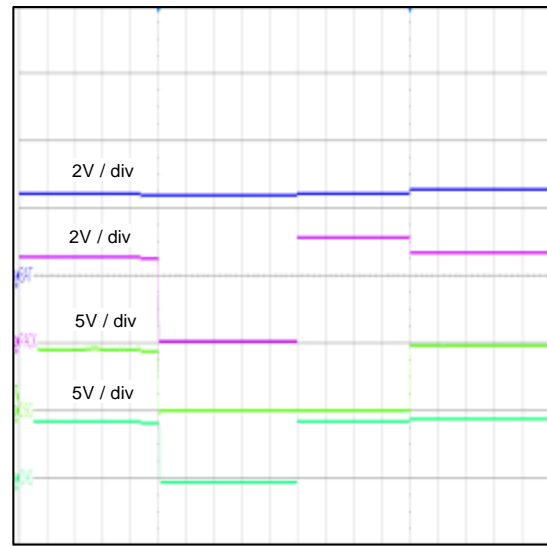

50ms / div

Figure 22. Undervoltage Protection Set and Clear

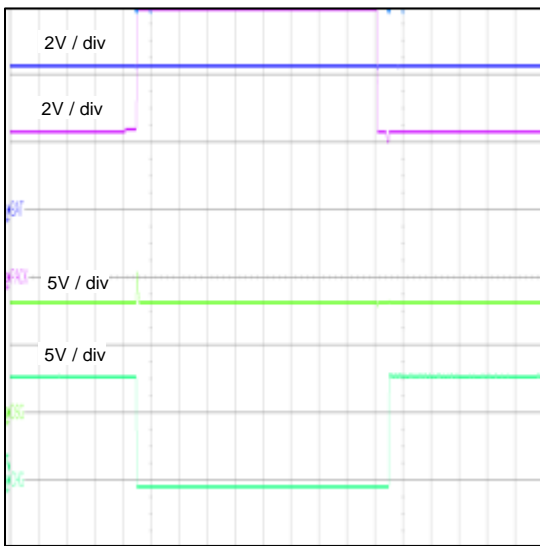

20ms / div

Figure 23. Overcurrent in Charge Protection Set and Clear

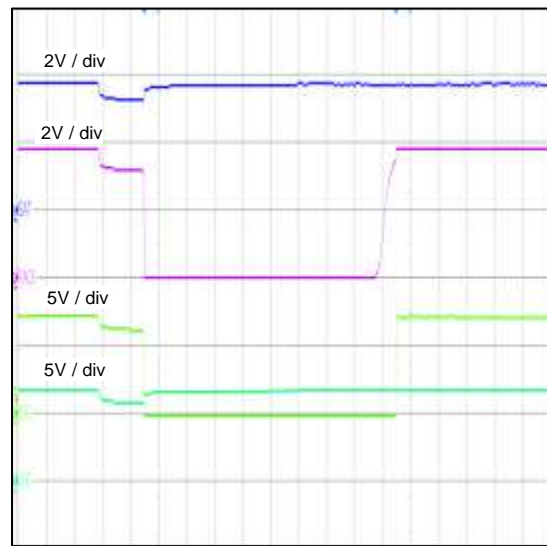

20ms / div

Figure 24. Overcurrent in Discharge Protection Set and Clear

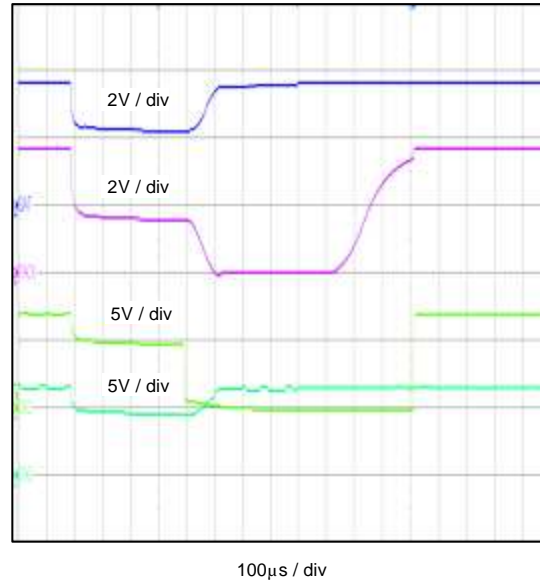

Figure 25. Short-Circuit in Discharge Protection Set and Clear

9 Power Supply Recommendation

9.1 Power Supply Decoupling

Both the VPWR input pin and the REG25 output pin require low equivalent series resistance (ESR) ceramic capacitors placed as closely as possible to the respective pins to optimize ripple rejection and provide a stable and dependable power rail that is resilient to line transients. A 0.1-µF capacitor at the VPWR and a 1-µF capacitor at REG25 will suffice for satisfactory device performance.

10 Layout

10.1 Layout Guidelines

10.1.1 Li-Ion Cell Connections

For highest voltage measurement accuracy, it is critical to connect the BAT pin directly to the battery terminal PCB pad. This avoids measurement errors caused by IR drops when high charge or discharge currents are flowing. Connecting right at the positive battery terminal with a Kelvin connection ensures the elimination of parasitic resistance between the point of measurement and the actual battery terminal. Likewise the low current ground return for the fuel gauge and all related passive components should be star-connected right at the negative battery terminal. This technique minimizes measurement error due to current-induced ground offsets and also improves noise performance through prevention of ground bounce that could occur with high current and low current returns intersecting ahead of the battery ground. The bypass capacitor for this sense line needs to be placed as close as possible to the BAT input pin.

10.1.2 Sense Resistor Connections

Kelvin connections at the sense resistor are just as critical as those for the battery terminals themselves. The differential traces should be connected at the inside of the sense resistor pads and not anywhere along the high current trace path in order to prevent false increases to measured current that could result when measuring between the sum of the sense resistor and trace resistance between the tap points. In addition, the routing of these leads from the sense resistor to the input filter network and finally into the SRP and SRN pins needs to be as closely matched in length as possible else additional measurement offset could occur. It is further recommended to add copper trace or pour-based "guard rings" around the perimeter of the filter network and coulomb counter inputs to shield these sensitive pins from radiated EMI into the sense nodes. This prevents differential voltage shifts that could be interpreted as real current change to the fuel gauge. All of the filter components need to be placed as close as possible to the coulomb counter input pins.

10.1.3 Thermistor Connections

The thermistor sense input should include a ceramic bypass capacitor placed as close to the TS input pin as possible. The capacitor helps to filter measurements of any stray transients as the voltage bias circuit pulses periodically during temperature sensing windows.

10.1.4 FET Connections

The battery current transmission path through the FETs should be routed with large copper pours to provide the lowest resistance path possible to the system. Depending on package type, thermal vias can be placed in the package land pattern's thermal pad to reduce thermal impedance and improve heat dissipation from the package to the board, protecting the FETs during high system loading conditions. In addition, it is preferable to locate the FETs and other heat generating components away from the low power pack electronics to reduce the chance of temperature drift and associated impacts to data converter measurements. In the event of FET overheating, keeping reasonable distance between the most critical components, such as the fuel gauge, and the FETs helps to decrease the risk of thermal breakdown to the more fragile components.

10.1.5 ESD Component Connections

The ESD components included in the reference design that connect across the back-to-back FETs as well as from PACK+ to ground require trace connections that are as wide and short as possible in order to minimize loop inductance in their return path. This ensures impedance is lowest at the AC loop through the series capacitors and makes this route most attractive for ESD transients such that they are conducted away from the vulnerable low voltage, low power fuel gauge and passive components. The series resistors and Zener diodes connected to the serial communications lines should be placed as close as possible to the battery pack connector to keep large ESD currents confined to an area distant from the fuel gauge electronics. Further, all ESD components referred to ground should be single-point connected to the PACK– terminal if possible. This reduces the possibility of ESD coupling into other sensitive nodes well ahead of the PACK– ground return.

Layout Guidelines (continued)

10.1.6 High Current and Low Current Path Separation

For best possible noise performance, it is extremely important to separate the low current and high current loops to different areas of the board layout. The fuel gauge and all support components should be situated on one side of the boards and tap off of the high current loop (for measurement purposes) at the sense resistor. Routing the low current ground around instead of under high current traces will further help to improve noise rejection. Last, the high current path should be confined to a small loop from the battery, through the FETs, into the PACK connector, and back.

10.2 Layout Example

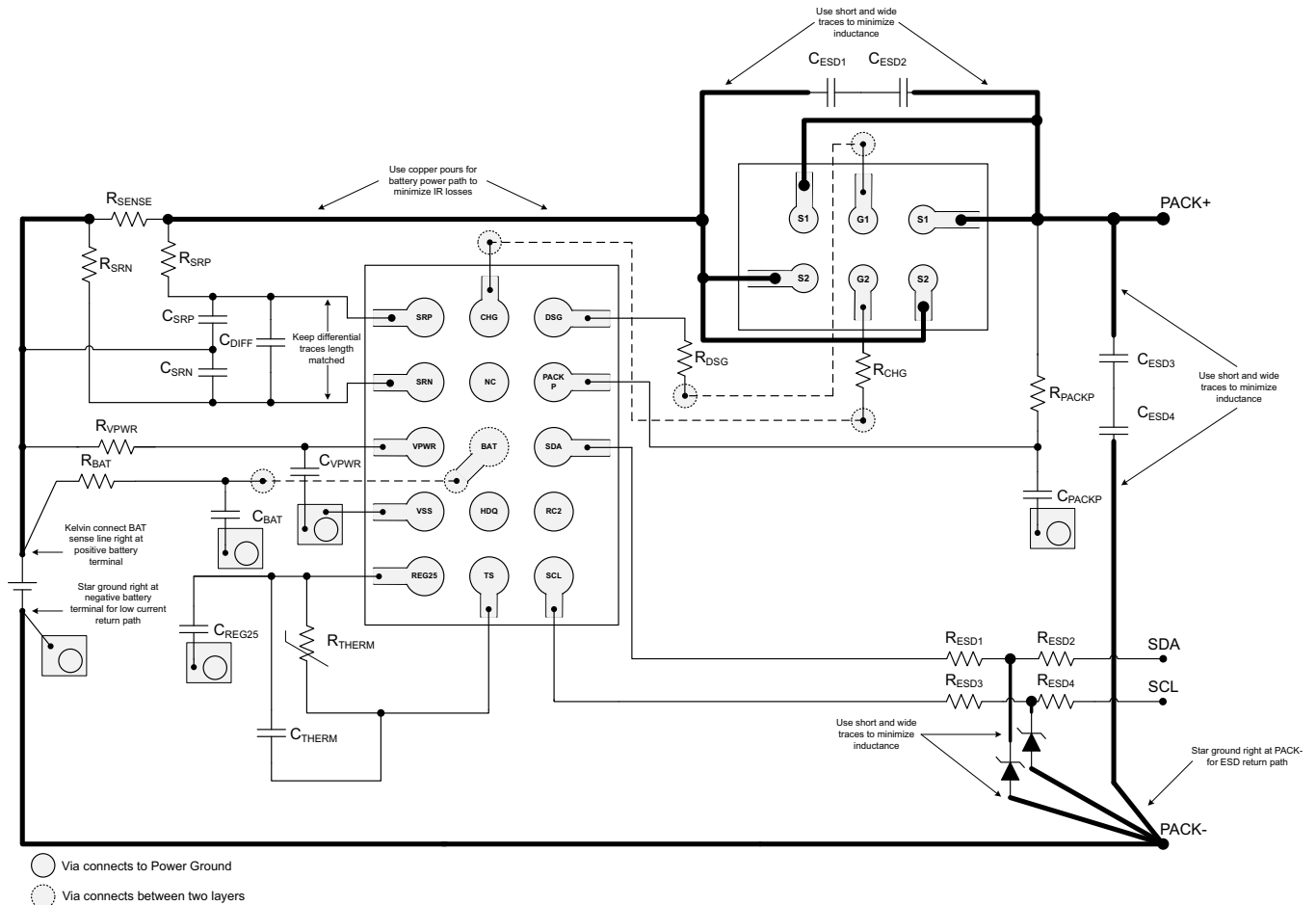

Figure 26. bq27742-G1 Board Layout

11 器件和文档支持

11.1 文档支持

11.1.1 相关文档

1. 《[bq27742-G1 技术参考手册](#)》(SLUUAX0)
2. 用户指南《[bq27742EVM 单节电池 Impedance Track™ 技术评估模块](#)》(文献编号: SLUUAH1)

11.2 接收文档更新通知

要接收文档更新通知，请导航至 TI.com 上的器件产品文件夹。单击右上角的“通知我”进行注册，即可每周接收产品信息更改摘要。有关更改的详细信息，请查看任何已修订文档中包含的修订历史记录。

11.3 社区资源

下列链接提供到 TI 社区资源的连接。链接的内容由各个分销商“按照原样”提供。这些内容并不构成 TI 技术规范，并且不一定反映 TI 的观点；请参阅 TI 的《[使用条款](#)》。

TI E2E™ 在线社区 [TI 的工程师对工程师 \(E2E\) 社区](#)。此社区的创建目的在于促进工程师之间的协作。在 e2e.ti.com 中，您可以咨询问题、分享知识、拓展思路并与同行工程师一道帮助解决问题。

设计支持 [TI 参考设计支持](#) 可帮助您快速查找有帮助的 E2E 论坛、设计支持工具以及技术支持的联系信息。

11.4 商标

Impedance Track, NanoFree, E2E are trademarks of Texas Instruments.
All other trademarks are the property of their respective owners.

11.5 静电放电警告



ESD 可能会损坏该集成电路。德州仪器 (TI) 建议通过适当的预防措施处理所有集成电路。如果不遵守正确的处理措施和安装程序，可能会损坏集成电路。

ESD 的损坏小至导致微小的性能降级，大至整个器件故障。精密的集成电路可能更容易受到损坏，这是因为非常细微的参数更改都可能会导致器件与其发布的规格不相符。

11.6 Glossary

[SLYZ022](#) — *TI Glossary*.

This glossary lists and explains terms, acronyms, and definitions.

12 机械、封装和可订购信息

以下页面包含机械、封装和可订购信息。这些信息是指定器件的最新可用数据。数据如有变更，恕不另行通知和修订此文档。如欲获取此数据表的浏览器版本，请参阅左侧的导航。

PACKAGING INFORMATION

Orderable part number	Status (1)	Material type (2)	Package Pins	Package qty Carrier	RoHS (3)	Lead finish/ Ball material (4)	MSL rating/ Peak reflow (5)	Op temp (°C)	Part marking (6)
BQ27742YZFR-G1	Active	Production	DSBGA (YZF) 15	3000 LARGE T&R	Yes	SNAGCU	Level-1-260C-UNLIM	-40 to 85	BQ27742
BQ27742YZFR-G1.A	Active	Production	DSBGA (YZF) 15	3000 LARGE T&R	Yes	SNAGCU	Level-1-260C-UNLIM	-40 to 85	BQ27742
BQ27742YZFR-G1.B	Active	Production	DSBGA (YZF) 15	3000 LARGE T&R	Yes	SNAGCU	Level-1-260C-UNLIM	-40 to 85	BQ27742
BQ27742YZFT-G1	Active	Production	DSBGA (YZF) 15	250 SMALL T&R	Yes	SNAGCU	Level-1-260C-UNLIM	-40 to 85	BQ27742
BQ27742YZFT-G1.A	Active	Production	DSBGA (YZF) 15	250 SMALL T&R	Yes	SNAGCU	Level-1-260C-UNLIM	-40 to 85	BQ27742
BQ27742YZFT-G1.B	Active	Production	DSBGA (YZF) 15	250 SMALL T&R	Yes	SNAGCU	Level-1-260C-UNLIM	-40 to 85	BQ27742

(1) **Status:** For more details on status, see our [product life cycle](#).

(2) **Material type:** When designated, preproduction parts are prototypes/experimental devices, and are not yet approved or released for full production. Testing and final process, including without limitation quality assurance, reliability performance testing, and/or process qualification, may not yet be complete, and this item is subject to further changes or possible discontinuation. If available for ordering, purchases will be subject to an additional waiver at checkout, and are intended for early internal evaluation purposes only. These items are sold without warranties of any kind.

(3) **RoHS values:** Yes, No, RoHS Exempt. See the [TI RoHS Statement](#) for additional information and value definition.

(4) **Lead finish/Ball material:** Parts may have multiple material finish options. Finish options are separated by a vertical ruled line. Lead finish/Ball material values may wrap to two lines if the finish value exceeds the maximum column width.

(5) **MSL rating/Peak reflow:** The moisture sensitivity level ratings and peak solder (reflow) temperatures. In the event that a part has multiple moisture sensitivity ratings, only the lowest level per JEDEC standards is shown. Refer to the shipping label for the actual reflow temperature that will be used to mount the part to the printed circuit board.

(6) **Part marking:** There may be an additional marking, which relates to the logo, the lot trace code information, or the environmental category of the part.

Multiple part markings will be inside parentheses. Only one part marking contained in parentheses and separated by a "~" will appear on a part. If a line is indented then it is a continuation of the previous line and the two combined represent the entire part marking for that device.

Important Information and Disclaimer: The information provided on this page represents TI's knowledge and belief as of the date that it is provided. TI bases its knowledge and belief on information provided by third parties, and makes no representation or warranty as to the accuracy of such information. Efforts are underway to better integrate information from third parties. TI has taken and continues to take reasonable steps to provide representative and accurate information but may not have conducted destructive testing or chemical analysis on incoming materials and chemicals. TI and TI suppliers consider certain information to be proprietary, and thus CAS numbers and other limited information may not be available for release.

In no event shall TI's liability arising out of such information exceed the total purchase price of the TI part(s) at issue in this document sold by TI to Customer on an annual basis.

TAPE AND REEL INFORMATION

QUADRANT ASSIGNMENTS FOR PIN 1 ORIENTATION IN TAPE

*All dimensions are nominal

Device	Package Type	Package Drawing	Pins	SPQ	Reel Diameter (mm)	Reel Width W1 (mm)	A0 (mm)	B0 (mm)	K0 (mm)	P1 (mm)	W (mm)	Pin1 Quadrant
BQ27742YZFR-G1	DSBGA	YZF	15	3000	180.0	8.4	2.06	2.88	0.69	4.0	8.0	Q1
BQ27742YZFT-G1	DSBGA	YZF	15	250	180.0	8.4	2.06	2.88	0.69	4.0	8.0	Q1

TAPE AND REEL BOX DIMENSIONS



*All dimensions are nominal

Device	Package Type	Package Drawing	Pins	SPQ	Length (mm)	Width (mm)	Height (mm)
BQ27742YZFR-G1	DSBGA	YZF	15	3000	182.0	182.0	20.0
BQ27742YZFT-G1	DSBGA	YZF	15	250	182.0	182.0	20.0

YZF0015

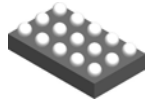

PACKAGE OUTLINE

DSBGA - 0.625 mm max height

DIE SIZE BALL GRID ARRAY

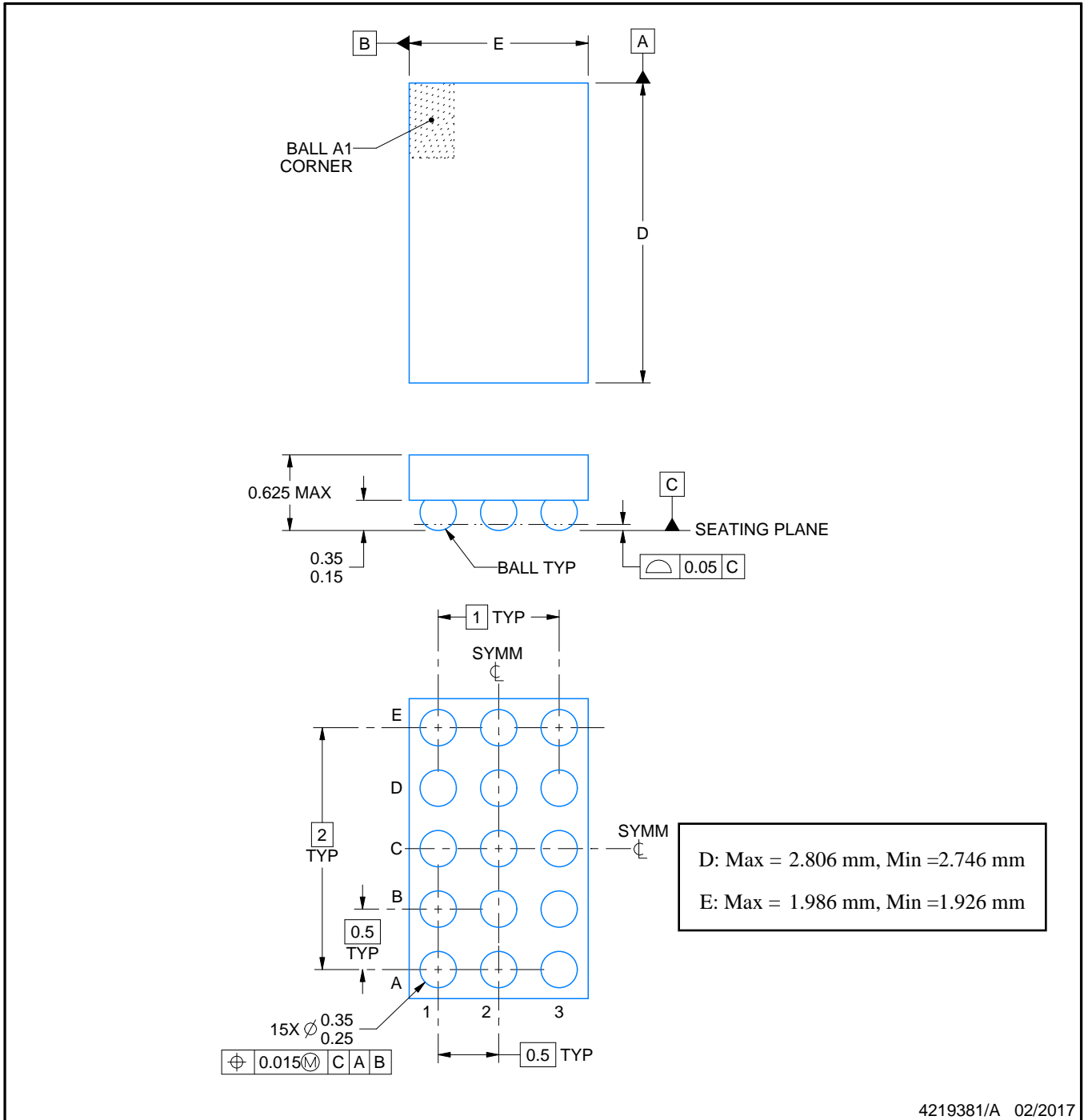

4219381/A 02/2017

NOTES:

NanoFree is a trademark of Texas Instruments.

1. All linear dimensions are in millimeters. Any dimensions in parenthesis are for reference only. Dimensioning and tolerancing per ASME Y14.5M.
2. This drawing is subject to change without notice.
3. NanoFree™ package configuration.

EXAMPLE BOARD LAYOUT

YZF0015

DSBGA - 0.625 mm max height

DIE SIZE BALL GRID ARRAY

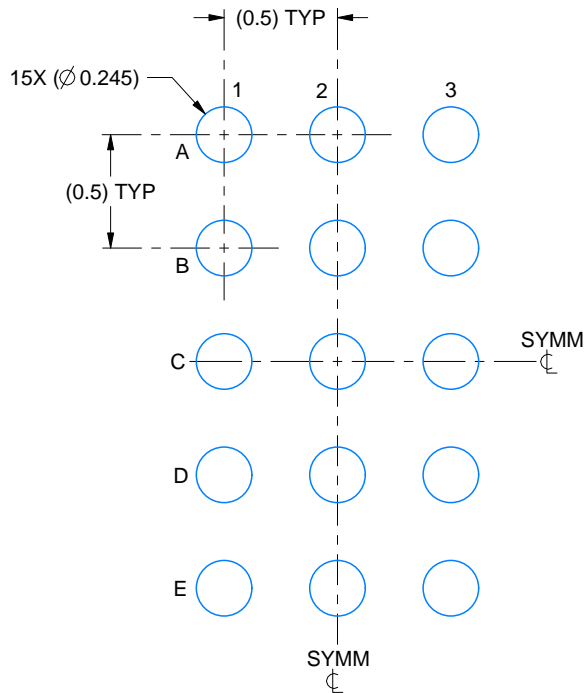

LAND PATTERN EXAMPLE
EXPOSED METAL SHOWN
SCALE:30X

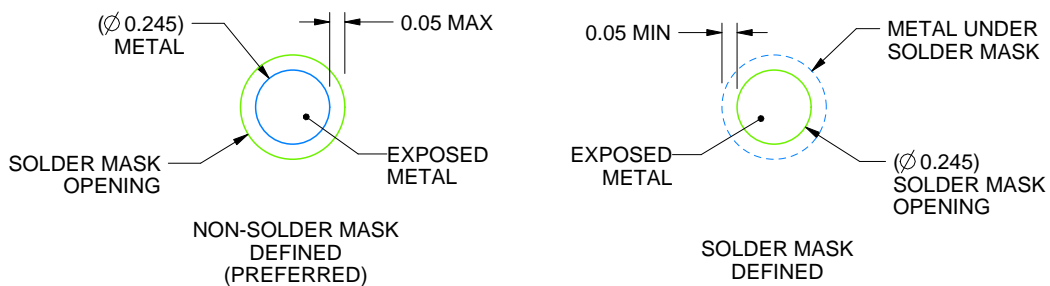

SOLDER MASK DETAILS
NOT TO SCALE

4219381/A 02/2017

NOTES: (continued)

- Final dimensions may vary due to manufacturing tolerance considerations and also routing constraints. For more information, see Texas Instruments literature number SNVA009 (www.ti.com/lit/snva009).

EXAMPLE STENCIL DESIGN

YZF0015

DSBGA - 0.625 mm max height

DIE SIZE BALL GRID ARRAY

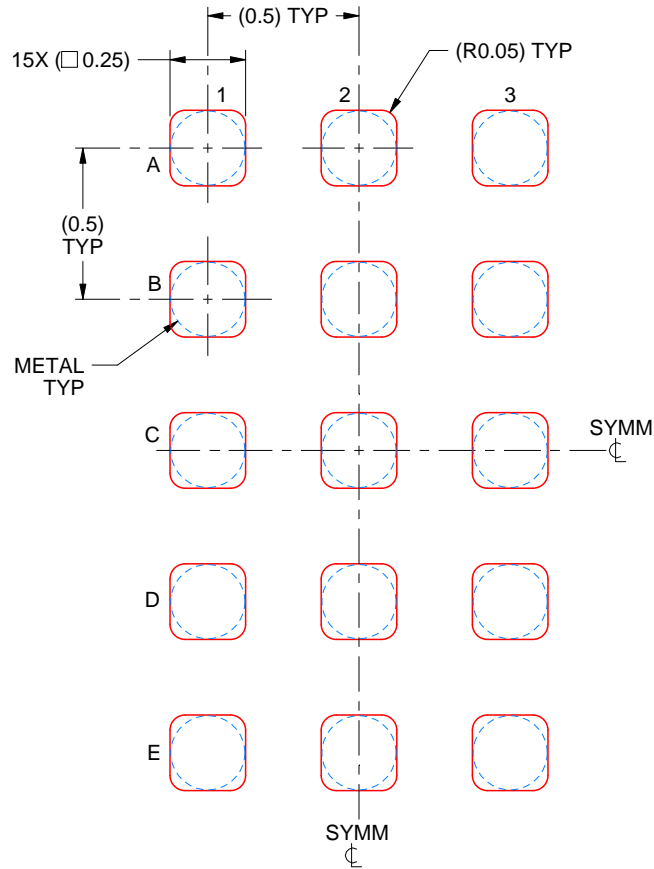

SOLDER PASTE EXAMPLE
BASED ON 0.1 mm THICK STENCIL
SCALE:40X

4219381/A 02/2017

NOTES: (continued)

5. Laser cutting apertures with trapezoidal walls and rounded corners may offer better paste release.

重要通知和免责声明

TI“按原样”提供技术和可靠性数据（包括数据表）、设计资源（包括参考设计）、应用或其他设计建议、网络工具、安全信息和其他资源，不保证没有瑕疵且不做任何明示或暗示的担保，包括但不限于对适销性、与某特定用途的适用性或不侵犯任何第三方知识产权的暗示担保。

这些资源可供使用 TI 产品进行设计的熟练开发人员使用。您将自行承担以下全部责任：(1) 针对您的应用选择合适的 TI 产品，(2) 设计、验证并测试您的应用，(3) 确保您的应用满足相应标准以及任何其他安全、安保法规或其他要求。

这些资源如有变更，恕不另行通知。TI 授权您仅可将这些资源用于研发本资源所述的 TI 产品的相关应用。严禁以其他方式对这些资源进行复制或展示。您无权使用任何其他 TI 知识产权或任何第三方知识产权。对于因您对这些资源的使用而对 TI 及其代表造成的任何索赔、损害、成本、损失和债务，您将全额赔偿，TI 对此概不负责。

TI 提供的产品受 [TI 销售条款](#)、[TI 通用质量指南](#) 或 [ti.com](#) 上其他适用条款或 TI 产品随附的其他适用条款的约束。TI 提供这些资源并不会扩展或以其他方式更改 TI 针对 TI 产品发布的适用的担保或担保免责声明。除非德州仪器 (TI) 明确将某产品指定为定制产品或客户特定产品，否则其产品均为按确定价格收入目录的标准通用器件。

TI 反对并拒绝您可能提出的任何其他或不同的条款。

版权所有 © 2025，德州仪器 (TI) 公司

最后更新日期：2025 年 10 月