

## CD74AC14 六路施密特触发反相器

### 1 特性

- 工作电压范围为 1.5V 至 5.5V，并在电源电压的 30% 时具有平衡的抗噪性能
- 双极 F、AS 和 S 的速度，同时功耗显著降低
- 具有比标准反相器更高的噪声抗扰度
- 工作时的压摆率比标准的输入上升和下降速率慢很多
- 平衡传播延迟
- $\pm 24\text{mA}$  输出驱动电流 - 扇出至 15 个 F 器件
- 防 SCR 闩锁 CMOS 工艺和电路设计

### 2 说明

CD74AC14 包含六个独立的逆变器。

#### 封装信息

器件型号	封装 1	封装尺寸 2	本体尺寸 3
CD74AC14	D (SOIC, 14)	8.65mm × 6mm	8.65mm × 3.9mm
	N (PDIP, 14)	19.3mm × 9.4mm	19.3mm × 6.35mm

1. 有关更多信息，请参阅节 10。
2. 封装尺寸 (长 × 宽) 为标称值，并包括引脚 (如适用)。
3. 本体尺寸 (长 × 宽) 为标称值，不包括引脚。



简化原理图



## Table of Contents

<b>1 特性</b> .....	<b>1</b>	6.3 Device Functional Modes.....	<b>7</b>
<b>2 说明</b> .....	<b>1</b>	<b>7 Application and Implementation</b> .....	<b>8</b>
<b>3 Pin Configuration and Functions</b> .....	<b>3</b>	7.1 Power Supply Recommendations.....	<b>8</b>
<b>4 Specifications</b> .....	<b>4</b>	7.2 Layout.....	<b>8</b>
4.1 Absolute Maximum Ratings.....	<b>4</b>	<b>8 Device and Documentation Support</b> .....	<b>9</b>
4.2 Recommended Operating Conditions.....	<b>4</b>	8.1 Documentation Support (Analog).....	<b>9</b>
4.3 Thermal Information.....	<b>4</b>	8.2 接收文档更新通知.....	<b>9</b>
4.4 Electrical Characteristics.....	<b>5</b>	8.3 支持资源.....	<b>9</b>
4.5 Switching Characteristics.....	<b>5</b>	8.4 Trademarks.....	<b>9</b>
4.6 Operating Characteristics.....	<b>5</b>	8.5 静电放电警告.....	<b>9</b>
<b>5 Parameter Measurement Information</b> .....	<b>6</b>	8.6 术语表.....	<b>9</b>
<b>6 Detailed Description</b> .....	<b>7</b>	<b>9 Revision History</b> .....	<b>9</b>
6.1 Overview.....	<b>7</b>	<b>10 Mechanical, Packaging, and Orderable Information</b> .....	<b>10</b>
6.2 Functional Block Diagram.....	<b>7</b>		

### 3 Pin Configuration and Functions



图 3-1. N or D Package, 14-Pin PDIP or SOIC Top View

表 3-1. Pin Functions

PIN		I/O	DESCRIPTION
NAME	NO.		
1A	1	Input	Channel 1, Input A
1Y	2	Output	Channel 1, Output Y
2A	3	Input	Channel 2, Input A
2Y	4	Output	Channel 2, Output Y
3A	5	Input	Channel 3, Input A
3Y	6	Output	Channel 3, Output Y
GND	7	—	Ground
4Y	8	Output	Channel 4, Output Y
4A	9	Input	Channel 4, Input A
5Y	10	Output	Channel 5, Output Y
5A	11	Input	Channel 5, Input A
6Y	12	Output	Channel 6, Output Y
6A	13	Input	Channel 6, Input A
V <sub>CC</sub>	14	—	Positive Supply

## 4 Specifications

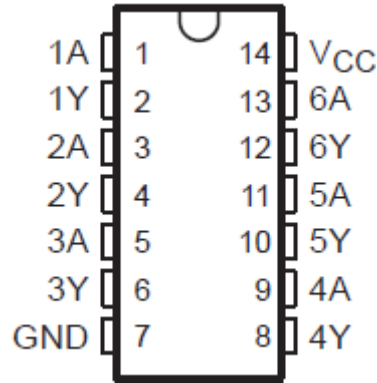
### 4.1 Absolute Maximum Ratings

over operating free-air temperature range (unless otherwise noted) <sup>(1)</sup>

		MIN	MAX	UNIT
V <sub>CC</sub>	Supply voltage range	-0.5	6	V
I <sub>IK</sub>	Input clamp current	(V <sub>I</sub> < 0 or V <sub>I</sub> > V <sub>CC</sub> ) <sup>1</sup>		±20 mA
I <sub>OK</sub>	Output clamp current	(V <sub>O</sub> < 0 or V <sub>O</sub> > V <sub>CC</sub> ) <sup>1</sup>		±50 mA
	Continuous output current	(V <sub>O</sub> = 0 to V <sub>CC</sub> )		±50 mA
	Continuous current through V <sub>CC</sub> or GND			±100 mA
T <sub>stg</sub>	Storage temperature range	-65	150	°C

- (1) Stresses beyond those listed under *Absolute Maximum Ratings* may cause permanent damage to the device. These are stress ratings only, which do not imply functional operation of the device at these or any other conditions beyond those indicated under *Recommended Operating Conditions*. Exposure to absolute-maximum-rated conditions for extended periods may affect device reliability.

### 4.2 Recommended Operating Conditions

over operating free-air temperature range (unless otherwise noted)

		T <sub>A</sub> = 25°C		- 55°C to 125°C		- 40°C to 85°C		UNIT
		MIN	MAX	MIN	MAX	MIN	MAX	
V <sub>CC</sub>	Supply voltage	1.5	5.5	1.5	5.5	1.5	5.5	V
V <sub>I</sub>	Input voltage	0	V <sub>CC</sub>	0	V <sub>CC</sub>	0	V <sub>CC</sub>	V
V <sub>O</sub>	Output voltage	0	V <sub>CC</sub>	0	V <sub>CC</sub>	0	V <sub>CC</sub>	V
I <sub>OH</sub>	High-level output current	V <sub>CC</sub> = 4.5 V to 5.5 V		- 24		- 24		mA
I <sub>OL</sub>	Low-level output current	V <sub>CC</sub> = 4.5 V to 5.5 V		24		24		mA

### 4.3 Thermal Information

THERMAL METRIC <sup>(1)</sup>		CD74AC14		UNIT
		N (PDIP)	D (SOIC)	
		14 PINS	14 PINS	
R <sub>θJA</sub>	Junction-to-ambient thermal resistance	80	89.9	°C/W

- (1) For more information about traditional and new thermal metrics, see the *IC Package Thermal Metrics* application report ([SPRA953](#)).

## 4.4 Electrical Characteristics

over operating free-air temperature range (unless otherwise noted)

PARAMETER	TEST CONDITIONS	V <sub>CC</sub>	TA = 25°C		- 55°C to 125°C		- 40°C to 85°C		UNIT
			MIN	MAX	MIN	MAX	MIN	MAX	
V <sub>T+</sub> Positive-going threshold		5 V	2.6	3.4	2.6	3.4	2.6	3.4	V
V <sub>T-</sub> Negative-going threshold		5 V	1.6	2.4	1.6	2.4	1.6	2.4	V
ΔVT Hysteresis (V <sub>T+</sub> - V <sub>T-</sub> )		5 V	0.5		0.5		0.5		V
V <sub>OH</sub>	V <sub>I</sub> = V <sub>T+</sub>	I <sub>OH</sub> = -50 μA	1.5 V	1.4	1.4	1.4			V
			3 V	2.9	2.9	2.9			
			4.5 V	4.4	4.4	4.4			
		I <sub>OH</sub> = -4 mA	3 V	2.58	2.4	2.48			
			4.5 V	3.94	3.7	3.8			
			5.5 V		3.85				
V <sub>OL</sub>	V <sub>I</sub> = V <sub>T-</sub>	I <sub>OL</sub> = 50 μA	1.5 V		0.1	0.1	0.1		V
			3 V		0.1	0.1	0.1		
			4.5 V		0.1	0.1	0.1		
		I <sub>OL</sub> = 12 mA	3 V		0.36	0.5	0.44		
			4.5 V		0.36	0.5	0.44		
			5.5 V			1.65			
I <sub>I</sub>	V <sub>I</sub> = V <sub>CC</sub> or GND	5.5 V			± 0.1	± 0.1	± 0.1	μA	
			I <sub>CC</sub>	V <sub>I</sub> = V <sub>CC</sub> or GND	5.5 V			4	80
C <sub>i</sub>								10	10

- Test one output at a time, not exceeding 1-second duration. Measurement is made by forcing indicated current and measuring voltage to minimize power dissipation. Test verifies a minimum 50-Ω transmission-line drive capability at 85°C and 75-Ω transmission-line drive capability at 125°C.

## 4.5 Switching Characteristics

over operating free-air temperature range V<sub>CC</sub> = 5 V ± 0.5 V, C<sub>L</sub> = 50 pF (unless otherwise noted)

PARAMETER	FROM (INPUT)	TO (OUTPUT)	- 55°C TO 125°C		- 40°C TO 85°C		UNIT
			MIN	MAX	MIN	MAX	
t <sub>PLH</sub>	A	Y	2.6	10.5	2.7	9.5	ns
t <sub>PHL</sub>			2.6	10.5	2.7	9.5	

## 4.6 Operating Characteristics

V<sub>CC</sub> = 5 V, T<sub>A</sub> = 25°C

PARAMETER		TYP	UNIT
C <sub>pd</sub>	Power dissipation capacitance	45	pF

## 5 Parameter Measurement Information

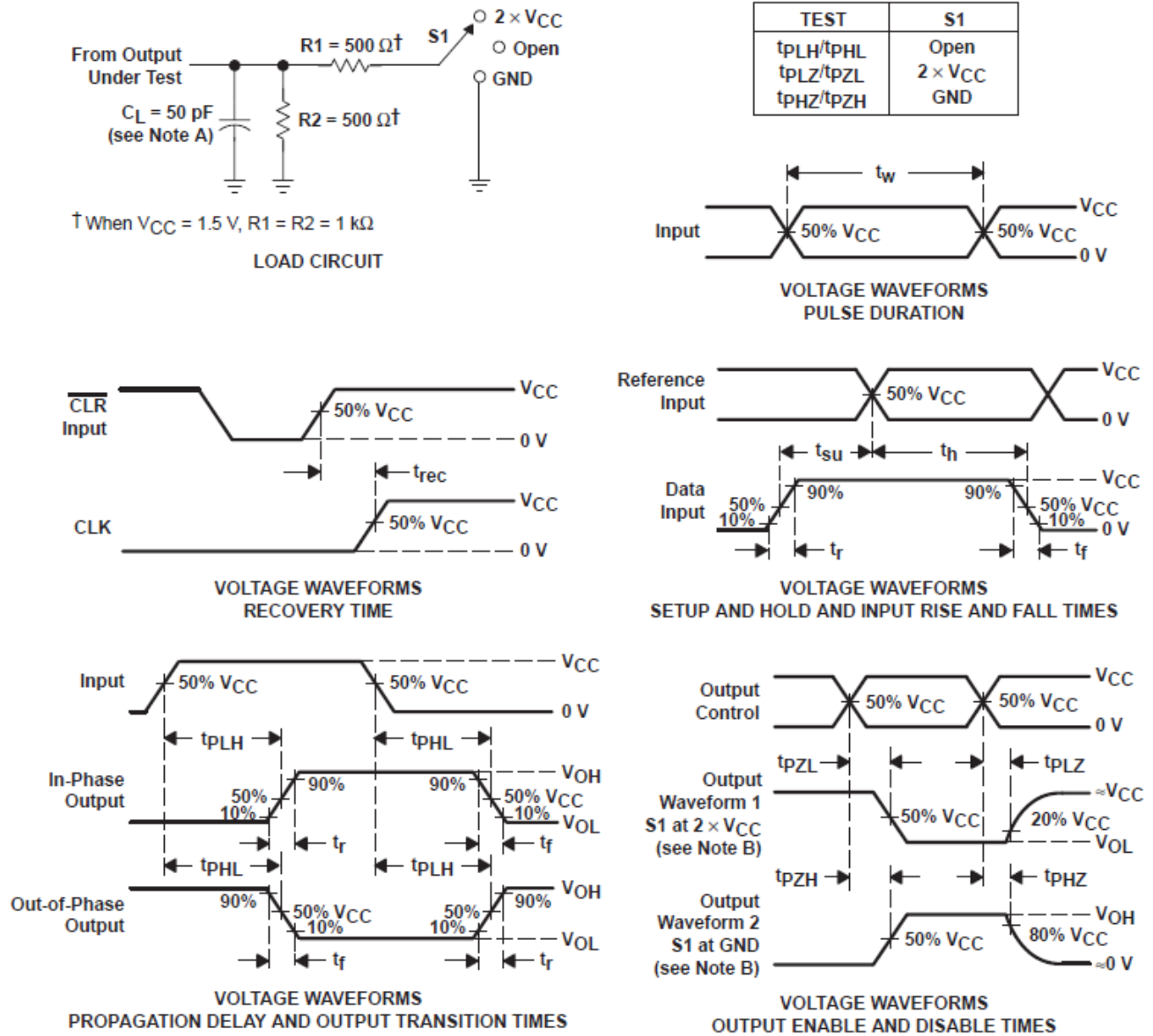

- NOTES:
- A.  $C_L$  includes probe and test-fixture capacitance.
  - B. Waveform 1 is for an output with internal conditions such that the output is low, except when disabled by the output control. Waveform 2 is for an output with internal conditions such that the output is high, except when disabled by the output control.
  - C. All input pulses are supplied by generators having the following characteristics:  $PRR \leq 1\text{ MHz}$ ,  $Z_O = 50\ \Omega$ ,  $t_r = 3\text{ ns}$ ,  $t_f = 3\text{ ns}$ . Phase relationships between waveforms are arbitrary.
  - D. For clock inputs,  $f_{max}$  is measured with the input duty cycle at 50%.
  - E. The outputs are measured one at a time, with one input transition per measurement.
  - F.  $t_{PLH}$  and  $t_{PHL}$  are the same as  $t_{pd}$ .
  - G.  $t_{PZL}$  and  $t_{PZH}$  are the same as  $t_{en}$ .
  - H.  $t_{PLZ}$  and  $t_{PHZ}$  are the same as  $t_{dis}$ .

图 5-1.

## 6 Detailed Description

### 6.1 Overview

The CD74AC14 device performs the Boolean function  $Y = \bar{A}$ . Each circuit functions as an independent inverter, but because of the Schmitt action, the inverters have different input threshold levels for positive-going ( $V_{T+}$ ) and negative-going ( $V_{T-}$ ) signals.

### 6.2 Functional Block Diagram



图 6-1. Logic Diagram, Each Inverter (Positive Logic)

### 6.3 Device Functional Modes

表 6-1. Function Table (Each Inverter)

INPUT	OUTPUT
A	Y
H	L
L	H

## 7 Application and Implementation

### 备注

以下应用部分中的信息不属于 TI 器件规格的范围，TI 不担保其准确性和完整性。TI 的客户应负责确定器件是否适用于其应用。客户应验证并测试其设计，以确保系统功能。

### 7.1 Power Supply Recommendations

The power supply can be any voltage between the MIN and MAX supply voltage rating located in the [表 4.2](#) table.

Each  $V_{CC}$  pin should have a good bypass capacitor to prevent power disturbance. For devices with a single supply,  $0.1 \mu\text{F}$  is recommended. If there are multiple  $V_{CC}$  pins,  $0.01 \mu\text{F}$  or  $0.022 \mu\text{F}$  is recommended for each power pin. It is acceptable to parallel multiple bypass caps to reject different frequencies of noise. A  $0.1 \mu\text{F}$  and  $1 \mu\text{F}$  are commonly used in parallel. The bypass capacitor should be installed as close to the power pin as possible for best results.

### 7.2 Layout

#### 7.2.1 Layout Guidelines

When using multiple bit logic devices, inputs should not float. In many cases, functions or parts of functions of digital logic devices are unused. Some examples are when only two inputs of a triple-input AND gate are used, or when only 3 of the 4-buffer gates are used. Such input pins should not be left unconnected because the undefined voltages at the outside connections result in undefined operational states.

Specified in [节 7.2.2](#) are rules that must be observed under all circumstances. All unused inputs of digital logic devices must be connected to a high or low bias to prevent them from floating. The logic level that should be applied to any particular unused input depends on the function of the device. Generally they will be tied to GND or  $V_{CC}$ , whichever makes more sense or is more convenient. It is acceptable to float outputs unless the part is a transceiver. If the transceiver has an output enable pin, it will disable the outputs section of the part when asserted. This will not disable the input section of the I/Os so they also cannot float when disabled.

#### 7.2.2 Layout Example



图 7-1. Layout Diagram



## 8 Device and Documentation Support

### 8.1 Documentation Support (Analog)

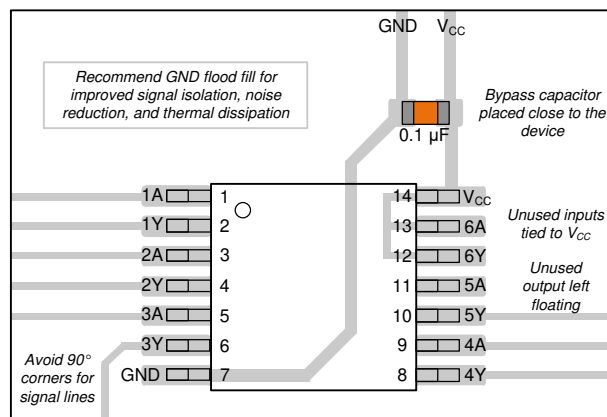
#### 8.1.1 Related Documentation

The table below lists quick access links. Categories include technical documents, support and community resources, tools and software, and quick access to sample or buy.

**表 8-1. Related Links**

PARTS	PRODUCT FOLDER	SAMPLE & BUY	TECHNICAL DOCUMENTS	TOOLS & SOFTWARE	SUPPORT & COMMUNITY
CD74AC14	<a href="#">Click here</a>	<a href="#">Click here</a>	<a href="#">Click here</a>	<a href="#">Click here</a>	<a href="#">Click here</a>

### 8.2 接收文档更新通知

要接收文档更新通知，请导航至 [ti.com](https://www.ti.com) 上的器件产品文件夹。点击 [通知](#) 进行注册，即可每周接收产品信息更改摘要。有关更改的详细信息，请查看任何已修订文档中包含的修订历史记录。

### 8.3 支持资源

[TI E2E™ 中文支持论坛](#) 是工程师的重要参考资料，可直接从专家处获得快速、经过验证的解答和设计帮助。搜索现有解答或提出自己的问题，获得所需的快速设计帮助。

链接的内容由各个贡献者“按原样”提供。这些内容并不构成 TI 技术规范，并且不一定反映 TI 的观点；请参阅 TI 的 [使用条款](#)。

### 8.4 Trademarks

TI E2E™ is a trademark of Texas Instruments.

所有商标均为其各自所有者的财产。

### 8.5 静电放电警告



静电放电 (ESD) 会损坏这个集成电路。德州仪器 (TI) 建议通过适当的预防措施处理所有集成电路。如果不遵守正确的处理和安装程序，可能会损坏集成电路。

ESD 的损坏小至导致微小的性能降级，大至整个器件故障。精密的集成电路可能更容易受到损坏，这是因为非常细微的参数更改都可能会导致器件与其发布的规格不相符。

### 8.6 术语表

[TI 术语表](#) 本术语表列出并解释了术语、首字母缩略词和定义。

## 9 Revision History

### Changes from Revision C (May 2023) to Revision D (August 2024) Page

• 添加了 <i>应用和实施</i> 部分、“器件和文档支持”部分以及 <i>机械、封装和可订购信息</i> 部分.....	1
• 向 <i>封装信息</i> 表中添加了封装尺寸.....	1
• 将整个数据表中的封装从 E 和 M 更改为 N 和 D.....	1
• Updated R <sup>θ</sup> JA values: D = 86 to 89.9, all values in °C/W.....	4

### Changes from Revision B (March 2004) to Revision C (May 2023) Page

• 添加了 <i>封装信息表</i> 、 <i>引脚功能表</i> 和 <i>热性能信息表</i> .....	1
---	---

## 10 Mechanical, Packaging, and Orderable Information

The following pages include mechanical, packaging, and orderable information. This information is the most current data available for the designated devices. This data is subject to change without notice and revision of this document. For browser-based versions of this data sheet, refer to the left-hand navigation.

**PACKAGING INFORMATION**

Orderable Device	Status (1)	Package Type	Package Drawing	Pins	Package Qty	Eco Plan (2)	Lead finish/ Ball material (6)	MSL Peak Temp (3)	Op Temp (°C)	Device Marking (4/5)	Samples
CD74AC14E	ACTIVE	PDIP	N	14	25	RoHS & Green	NIPDAU	N / A for Pkg Type	-55 to 125	CD74AC14E	<a href="#">Samples</a>
CD74AC14EE4	ACTIVE	PDIP	N	14	25	RoHS & Green	NIPDAU	N / A for Pkg Type	-55 to 125	CD74AC14E	<a href="#">Samples</a>
CD74AC14M	OBSOLETE	SOIC	D	14		TBD	Call TI	Call TI	-55 to 125	AC14M	
CD74AC14M96	ACTIVE	SOIC	D	14	2500	RoHS & Green	NIPDAU	Level-1-260C-UNLIM	-55 to 125	AC14M	<a href="#">Samples</a>

(1) The marketing status values are defined as follows:

**ACTIVE:** Product device recommended for new designs.

**LIFEBUY:** TI has announced that the device will be discontinued, and a lifetime-buy period is in effect.

**NRND:** Not recommended for new designs. Device is in production to support existing customers, but TI does not recommend using this part in a new design.

**PREVIEW:** Device has been announced but is not in production. Samples may or may not be available.

**OBSOLETE:** TI has discontinued the production of the device.

(2) **RoHS:** TI defines "RoHS" to mean semiconductor products that are compliant with the current EU RoHS requirements for all 10 RoHS substances, including the requirement that RoHS substance do not exceed 0.1% by weight in homogeneous materials. Where designed to be soldered at high temperatures, "RoHS" products are suitable for use in specified lead-free processes. TI may reference these types of products as "Pb-Free".

**RoHS Exempt:** TI defines "RoHS Exempt" to mean products that contain lead but are compliant with EU RoHS pursuant to a specific EU RoHS exemption.

**Green:** TI defines "Green" to mean the content of Chlorine (Cl) and Bromine (Br) based flame retardants meet JS709B low halogen requirements of <=1000ppm threshold. Antimony trioxide based flame retardants must also meet the <=1000ppm threshold requirement.

(3) MSL, Peak Temp. - The Moisture Sensitivity Level rating according to the JEDEC industry standard classifications, and peak solder temperature.

(4) There may be additional marking, which relates to the logo, the lot trace code information, or the environmental category on the device.

(5) Multiple Device Markings will be inside parentheses. Only one Device Marking contained in parentheses and separated by a "~" will appear on a device. If a line is indented then it is a continuation of the previous line and the two combined represent the entire Device Marking for that device.

(6) Lead finish/Ball material - Orderable Devices may have multiple material finish options. Finish options are separated by a vertical ruled line. Lead finish/Ball material values may wrap to two lines if the finish value exceeds the maximum column width.

**Important Information and Disclaimer:**The information provided on this page represents TI's knowledge and belief as of the date that it is provided. TI bases its knowledge and belief on information provided by third parties, and makes no representation or warranty as to the accuracy of such information. Efforts are underway to better integrate information from third parties. TI has taken and continues to take reasonable steps to provide representative and accurate information but may not have conducted destructive testing or chemical analysis on incoming materials and chemicals. TI and TI suppliers consider certain information to be proprietary, and thus CAS numbers and other limited information may not be available for release.

In no event shall TI's liability arising out of such information exceed the total purchase price of the TI part(s) at issue in this document sold by TI to Customer on an annual basis.

**TAPE AND REEL INFORMATION**

**QUADRANT ASSIGNMENTS FOR PIN 1 ORIENTATION IN TAPE**

\*All dimensions are nominal

Device	Package Type	Package Drawing	Pins	SPQ	Reel Diameter (mm)	Reel Width W1 (mm)	A0 (mm)	B0 (mm)	K0 (mm)	P1 (mm)	W (mm)	Pin1 Quadrant
CD74AC14M96	SOIC	D	14	2500	330.0	12.4	3.75	3.75	1.15	8.0	12.0	Q1
CD74AC14M96	SOIC	D	14	2500	330.0	16.4	6.5	9.0	2.1	8.0	16.0	Q1
CD74AC14M96	SOIC	D	14	2500	330.0	16.4	6.5	9.0	2.1	8.0	16.0	Q1

**TAPE AND REEL BOX DIMENSIONS**

\*All dimensions are nominal

Device	Package Type	Package Drawing	Pins	SPQ	Length (mm)	Width (mm)	Height (mm)
CD74AC14M96	SOIC	D	14	2500	340.5	336.1	32.0
CD74AC14M96	SOIC	D	14	2500	356.0	356.0	35.0
CD74AC14M96	SOIC	D	14	2500	353.0	353.0	32.0

**TUBE**

\*All dimensions are nominal

Device	Package Name	Package Type	Pins	SPQ	L (mm)	W (mm)	T (μm)	B (mm)
CD74AC14E	N	PDIP	14	25	506	13.97	11230	4.32
CD74AC14E	N	PDIP	14	25	506	13.97	11230	4.32
CD74AC14EE4	N	PDIP	14	25	506	13.97	11230	4.32
CD74AC14EE4	N	PDIP	14	25	506	13.97	11230	4.32



# D0014A

# PACKAGE OUTLINE

## SOIC - 1.75 mm max height

SMALL OUTLINE INTEGRATED CIRCUIT



4220718/A 09/2016

### NOTES:

1. All linear dimensions are in millimeters. Dimensions in parenthesis are for reference only. Dimensioning and tolerancing per ASME Y14.5M.
2. This drawing is subject to change without notice.
3. This dimension does not include mold flash, protrusions, or gate burrs. Mold flash, protrusions, or gate burrs shall not exceed 0.15 mm, per side.
4. This dimension does not include interlead flash. Interlead flash shall not exceed 0.43 mm, per side.
5. Reference JEDEC registration MS-012, variation AB.



# EXAMPLE BOARD LAYOUT

D0014A

SOIC - 1.75 mm max height

SMALL OUTLINE INTEGRATED CIRCUIT



LAND PATTERN EXAMPLE  
SCALE:8X



SOLDER MASK DETAILS

4220718/A 09/2016

NOTES: (continued)

- 6. Publication IPC-7351 may have alternate designs.
- 7. Solder mask tolerances between and around signal pads can vary based on board fabrication site.

# EXAMPLE STENCIL DESIGN

D0014A

SOIC - 1.75 mm max height

SMALL OUTLINE INTEGRATED CIRCUIT



SOLDER PASTE EXAMPLE  
BASED ON 0.125 mm THICK STENCIL  
SCALE:8X

4220718/A 09/2016

NOTES: (continued)

8. Laser cutting apertures with trapezoidal walls and rounded corners may offer better paste release. IPC-7525 may have alternate design recommendations.
9. Board assembly site may have different recommendations for stencil design.

N (R-PDIP-T\*\*)

PLASTIC DUAL-IN-LINE PACKAGE

16 PINS SHOWN



- NOTES:
- A. All linear dimensions are in inches (millimeters).
  - B. This drawing is subject to change without notice.
  - Falls within JEDEC MS-001, except 18 and 20 pin minimum body length (Dim A).
  - The 20 pin end lead shoulder width is a vendor option, either half or full width.

## 重要声明和免责声明

TI“按原样”提供技术和可靠性数据（包括数据表）、设计资源（包括参考设计）、应用或其他设计建议、网络工具、安全信息和其他资源，不保证没有瑕疵且不做任何明示或暗示的担保，包括但不限于对适销性、某特定用途方面的适用性或不侵犯任何第三方知识产权的暗示担保。

这些资源可供使用 TI 产品进行设计的熟练开发人员使用。您将自行承担以下全部责任：(1) 针对您的应用选择合适的 TI 产品，(2) 设计、验证并测试您的应用，(3) 确保您的应用满足相应标准以及任何其他功能安全、信息安全、监管或其他要求。

这些资源如有变更，恕不另行通知。TI 授权您仅可将这些资源用于研发本资源所述的 TI 产品的应用。严禁对这些资源进行其他复制或展示。您无权使用任何其他 TI 知识产权或任何第三方知识产权。您应全额赔偿因在这些资源的使用中对 TI 及其代表造成的任何索赔、损害、成本、损失和债务，TI 对此概不负责。

TI 提供的产品受 [TI 的销售条款](#) 或 [ti.com](#) 上其他适用条款/TI 产品随附的其他适用条款的约束。TI 提供这些资源并不会扩展或以其他方式更改 TI 针对 TI 产品发布的适用的担保或担保免责声明。

TI 反对并拒绝您可能提出的任何其他或不同的条款。

邮寄地址：Texas Instruments, Post Office Box 655303, Dallas, Texas 75265

Copyright © 2024，德州仪器 (TI) 公司