

# DAC3xJ82 带有 12.5 Gbps JESD204B 接口的双通道、16 位、1.6/2.5 GSPS 数模转换器

## 1 特性

- 分辨率：16 位
- 最大采样率：
  - DAC37J82: 1.6GSPS
  - DAC38J82: 2.5GSPS
- 最大输入数据速率：1.23GSPS
- JESD204B 接口
  - 8 个 JESD204B 串行输入信道
  - 每信道最大位速率 12.5Gbps
  - 子类 1 多 DAC 同步
- 片上极低抖动锁相环 (PLL)
- 可选 1x - 16x 插值
- 具有 48 位数值控制振荡器 (NCO) / 或  $\pm n \times F_s/8$  的独立复杂混频器
- 宽频带数字正交调制器校正
- $\text{Sin}x/x$  校正滤波器
- 分数采样组延迟校正
- 经由输出复用器灵活路由至四个模拟输出
- 3/4 线制串行控制总线 (SPI)
- 集成温度传感器
- JTAG 边界扫描
- 与四通道 DAC37J84/DAC38J84 引脚兼容
- 功率耗散：2.5GSPS 时为 1.1W
- 封装：10mm x 10mm，144 焊球倒装芯片球状引脚栅格阵列 (BGA)

## 2 应用范围

- 蜂窝基站
- 分集传输
- 宽频带通信
- 直接数字合成 (DDS) 仪器
- 毫米波/微波回程
- 自动测试设备
- 线缆基础设施
- 雷达

## 3 说明

引脚兼容 DAC37J82/DAC38J82 系列是一款具有 JESD204B 接口的极低功率，16 位，双通道，1.6/2.5GSPS 数模转换器 (DAC)。最大输入数据速率为 1.23GSPS。

数字数据通过运行速率高达 12.5Gbps 的 1、2、4 或 8 条可配置串行 JESD204B 信道输入到器件中，这些信道具有片上端接和可编程均衡功能。此接口可实现基于 JESD204B 子类 1 SYSREF 的确定性延迟，并且可实现多个器件的完全同步。

此器件包括简化复杂发射架构的特性。具有超过 90dB 阻带衰减的完全可旁路 2x 至 16x 数字插值滤波器可简化数据接口和重建滤波器。一个片上 48 位数值控制振荡器 (NCO) 和独立复杂混频器可实现灵活且准确的载波信号放置。

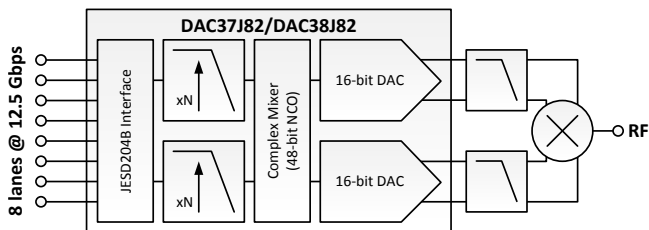
高性能低抖动 PLL 可简化器件计时，而又不会对动态范围造成太大影响。数字正交调制器校正 (QMC) 和组延迟校正 (QDC) 可在直接上行转换应用中为通道间的增益、偏移、相位以及组延迟实现完整的 IQ 补偿。一个可编程功率放大器 (PA) 保护机制可以在检测到输入数据的异常功率运行方式时提供 PA 保护。

DAC37J82/DAC38J82 系列提供四个模拟输出，并且来自两个内部数字路径的数据可经由输出复用器被路由至这四个 DAC 输出的任意两个输出。

器件信息<sup>(1)</sup>

部件号	封装	封装尺寸 (标称值)
DAC37J82	倒装芯片球状引脚栅格阵列 (FCBGA) (144)	10.00mm x 10.00mm
DAC38J82	FCBGA (144)	10.00mm x 10.00mm

(1) 如需了解所有可用封装，请见数据表末尾的可订购产品附录。



## 目录

<b>1</b>	特性 .....	<b>1</b>	7.2	Functional Block Diagram .....	<b>23</b>
<b>2</b>	应用范围 .....	<b>1</b>	7.3	Feature Description .....	<b>24</b>
<b>3</b>	说明 .....	<b>1</b>	7.4	Device Functional Modes .....	<b>55</b>
<b>4</b>	修订历史记录 .....	<b>2</b>	7.5	Register Map .....	<b>58</b>
<b>5</b>	<b>Pin Configuration and Functions</b> .....	<b>3</b>	<b>8</b>	<b>Applications and Implementation</b> .....	<b>102</b>
<b>6</b>	<b>Specifications</b> .....	<b>6</b>	8.1	Application Information .....	<b>102</b>
6.1	Absolute Maximum Ratings .....	<b>6</b>	8.2	Typical Applications .....	<b>102</b>
6.2	Handling Ratings .....	<b>6</b>	8.3	Initialization Set Up .....	<b>107</b>
6.3	Recommended Operating Conditions .....	<b>7</b>	<b>9</b>	<b>Power Supply Recommendations</b> .....	<b>108</b>
6.4	Thermal Information .....	<b>7</b>	<b>10</b>	<b>Layout</b> .....	<b>109</b>
6.5	DC Electrical Characteristics .....	<b>7</b>	10.1	Layout Guidelines .....	<b>109</b>
6.6	Digital Electrical Characteristics .....	<b>10</b>	10.2	Layout Examples .....	<b>110</b>
6.7	AC Electrical Characteristics .....	<b>11</b>	<b>11</b>	<b>器件和文档支持</b> .....	<b>112</b>
6.8	Timing Requirements .....	<b>13</b>	11.1	相关链接 .....	<b>112</b>
6.9	Switching Characteristics .....	<b>13</b>	11.2	Trademarks .....	<b>112</b>
6.10	Typical Characteristics .....	<b>14</b>	11.3	Electrostatic Discharge Caution .....	<b>112</b>
<b>7</b>	<b>Detailed Description</b> .....	<b>23</b>	11.4	术语表 .....	<b>112</b>
7.1	Overview .....	<b>23</b>	<b>12</b>	<b>机械封装和可订购信息</b> .....	<b>113</b>

## 4 修订历史记录

<b>Changes from Revision A (January 2014) to Revision B</b>		<b>Page</b>
<hr/>		
<b>Changes from Original (January 2014) to Revision A</b>		<b>Page</b>
<hr/>		
• 已更改 状态从产品预览更改为生产数据 .....		<b>1</b>
• Changed Pin Configuration .....		<b>3</b>

**Device Comparison Table**

DEVICE	MAXIMUM SAMPLE RATE	PACKAGE DRAWING/TYPE <sup>(1)</sup>	T <sub>A</sub>
DAC37J82IAAV	1.6 GSPS	AAV/144-ball flip chip BGA	–40°C to 85°C
DAC38J82IAAV	2.5 GSPS	AAV/144-ball flip chip BGA	–40°C to 85°C

(1) MSL Peak Temperature: Level-3-260C-168 HR

## 5 Pin Configuration and Functions

**144-Ball Flip Chip BGA  
AAV Package  
(Top View)**

	A	B	C	D	E	F	G	H	J	K	L	M	
12	GND	IOUTAP	IOUTAN	IOUTBN	IOUTBP	GND	GND	IOUTCP	IOUTCN	IOUTDN	IOUTDP	GND	12
11	GND	GND	GND	GND	GND	GND	GND	GND	GND	GND	GND	GND	11
10	DACCLKP	VDDAPLL18	VDDAREF18	VDDADAC33	VDDADAC33	EXTIO	RBIAS	VDDADAC33	VDDADAC33	VDDAREF18	SDIO	SDO	10
9	DACCLKN	VDDAPLL18	LPF	VDDDAC09	VDDDAC09	VDDDAC09	VDDDAC09	VDDDAC09	VDDDAC09	ATEST	SCLK	SDENB	9
8	VDDCLK09	VDDCLK09	GND	GND	GND	GND	GND	GND	GND	RESETB	ALARM	SLEEP	8
7	SYSREFP	SYNCPB	VDDS18	VQPS18	GND	GND	GND	GND	VDDDIG09	VDDIO18	SYNC_N_CD	NC	7
6	SYSREFN	SYNCPN	VDDS18	VQPS18	GND	GND	GND	GND	VDDDIG09	VDDIO18	SYNC_N_AB	NC	6
5	GND	GND	IFORCE	VDDDIG09	GND	GND	GND	GND	VDDDIG09	TXENABLE	TDI	TDO	5
4	GND	GND	VSENSE	VDDDIG09	VDDDIG09	VDDDIG09	VDDDIG09	VDDDIG09	VDDDIG09	TCLK	TMS	GND	4
3	RX7P	GND	GND	VDDDIG09	AMUX1	VDDT09	VDDT09	AMUX0	TRSTB	TESTMODE	GND	RX3P	3
2	RX7N	GND	GND	GND	GND	VDDR18	VDDR18	GND	GND	GND	GND	RX3N	2
1	RX6N	RX6P	RX5P	RX5N	RX4N	RX4P	RX0P	RX0N	RX1N	RX1P	RX2P	RX2N	1
	A	B	C	D	E	F	G	H	J	K	L	M	

**Pin Functions**

PIN		I/O	DESCRIPTION
NAME	NUMBER		
ALARM	L8	O	CMOS output for ALARM condition. The ALARM output functionality is defined through the <i>config7</i> register. Default polarity is active high, but can be changed to active high via <i>config0</i> <i>alarm_out_pol</i> control bit. If not used it can be left open.
AMUX0	H3	I/O	Analog test pin for SerDes, Lane 0 to Lane 3. It can be left open if not used.
AMUX1	E3	I/O	Analog test pin for SerDes, Lane 4 to Lane 7. It can be left open if not used.
ATEST	K9	I/O	Analog test pin for DAC, references and PLL. It can be left open if not used.
DACCLKP	A10	I	Positive LVPECL clock input for DAC core with $V_{cm} = 0.5V$ . It can be PLL reference clock or external DAC sampling rate clock. If not used, DACCLK is self-biased with 100mV differential at $V_{cm} = 0.5V$ .
DACCLKN	A9	I	Complementary LVPECL clock input for DAC core. (see the DACCLKP description)
EXTIO	F10	I/O	Used as external reference input when internal reference is disabled through <i>config27</i> <i>extref_ena</i> = '1'. Used as internal reference output when <i>config27</i> <i>extref_ena</i> = '0' (default). Requires a 0.1 $\mu F$ decoupling capacitor to analog GND when used as reference output. It can be left open if not used.
GND	A12, F12, G12, M12, A11, B11, C11, D11, E11, F11, G11, H11, J11, K11, L11, M11, C8, D8, E8, F8, G8, H8, J8, E7, F7, G7, H7, E6, F6, G6, H6, A5, B5, E5, F5, G5, H5, A4, B4, M4, B3, C3, L3, B2, C2, D2, E2, H2, J2, K2, L2	I	These pins are ground for all supplies.
IFORCE	C5	I/O	Analog test pin for on chip parametric. It can be left open if not used.
IOUTAP	B12	O	A-Channel DAC current output. Must tied to GND if not used.
IOUTAN	C12	O	A-Channel DAC complementary current output. Must tied to GND if not used.
IOUTBP	E12	O	B-Channel DAC current output. Must tied to GND if not used.
IOUTBN	D12	O	B-Channel DAC complementary current output. Must tied to GND if not used.
IOUTCP	H12	O	C-Channel DAC current output. Must tied to GND if not used.
IOUTCN	J12	O	C-Channel DAC complementary current output. Must tied to GND if not used.
IOUTDP	L12	O	D-Channel DAC current output. Must tied to GND if not used.
IOUTDN	K12	O	D-Channel DAC complementary current output. Must tied to GND if not used.
LPF	C9	I/O	External PLL loop filter connection. It can be left open if not used.
RBIAS	G10	O	Full-scale output current bias. Change the full-scale output current through <i>coarse_dac(3:0)</i> . Expected to be 1.92k $\Omega$ to GND.
RESETB	K8	I	Active low input for chip RESET, which resets all the programming registers to their default state. Internal pull-up. It can be left open if not used.
RX0P	G1	I	CML SerDes interface lane 0 input, positive, expected to be AC coupled. It can be left open if not used.
RX0N	H1	I	CML SerDes interface lane 0 input, negative, expected to be AC coupled. It can be left open if not used.
RX1P	K1	I	CML SerDes interface lane 1 input, positive, expected to be AC coupled. It can be left open if not used.
RX1N	J1	I	CML SerDes interface lane 1 input, negative, expected to be AC coupled. It can be left open if not used.
RX2P	L1	I	CML SerDes interface lane 2 input, positive, expected to be AC coupled. It can be left open if not used.
RX2N	M1	I	CML SerDes interface lane 2 input, negative, expected to be AC coupled. It can be left open if not used.
RX3P	M3	I	CML SerDes interface lane 3 input, positive, expected to be AC coupled. It can be left open if not used.

**Pin Functions (continued)**

PIN		I/O	DESCRIPTION
NAME	NUMBER		
RX3N	M2	I	CML SerDes interface lane 3 input, negative, expected to be AC coupled. It can be left open if not used.
RX4P	F1	I	CML SerDes interface lane 4 input, positive, expected to be AC coupled. It can be left open if not used.
RX4N	E1	I	CML SerDes interface lane 4 input, negative, expected to be AC coupled. It can be left open if not used.
RX5P	C1	I	CML SerDes interface lane 5 input, positive, expected to be AC coupled. It can be left open if not used.
RX5N	D1	I	CML SerDes interface lane 5 input, negative, expected to be AC coupled. It can be left open if not used.
RX6P	B1	I	CML SerDes interface lane 6 input, positive, expected to be AC coupled. It can be left open if not used.
RX6N	A1	I	CML SerDes interface lane 6 input, negative, expected to be AC coupled. It can be left open if not used.
RX7P	A3	I	CML SerDes interface lane 7 input, positive, expected to be AC coupled. It can be left open if not used.
RX7N	A2	I	CML SerDes interface lane 7 input, negative, expected to be AC coupled. It can be left open if not used.
SYSREFP	A7	I	LVPECL SYSREF positive input with $V_{cm} = 0.5V$ . This positive/negative pair is captured with the rising edge of DACCLKP/N. It is used for JESD204B Subclass 1 deterministic latency and multiple DAC synchronization, which can be periodic or pulsed. If not used, it is self-biased with 100mV differential at $V_{cm} = 0.5V$ .
SYSREFN	A6	I	LVPECL SYSREF negative input with $V_{cm} = 0.5V$ . (See the SYSREFP description)
SCLK	L9	I	Serial interface clock. Internal pull-down. It can be left open if not used.
SDENB	M9	I	Active low serial data enable, always an input to the DAC37J82/DAC38J82. Internal pull-up. It can be left open if not used.
SDIO	L10	I/O	Serial interface data. Bi-directional in 3-pin mode (default) and 4-pin mode. Internal pull-down. It can be left open if not used.
SDO	M10	O	Uni-directional serial interface data in 4-pin mode. The SDO pin is tri-stated in 3-pin interface mode (default). It can be left open if not used.
SLEEP	M8	I	Active high asynchronous hardware power-down input. Internal pull-down. It can be left open if not used.
SYNCBP	B7	O	Synchronization request to transmitter, LVDS positive output. It can be left open if not used.
SYNCBN	B6	O	Synchronization request to transmitter, LVDS negative output. It can be left open if not used.
SYNC_N_AB	L6	O	Synchronization request to transmitter, CMOS output. Defaults to link 0, but can be programmable for any link. It can be left open if not used.
SYNC_N_CD	L7	O	Synchronization request to transmitter, CMOS output. Defaults to link 1, but can be programmable for any link. It can be left open if not used.
TCLK	K4	I	JTAG test clock. It can be left open if not used.
TDI	L5	I	JTAG test data in. It can be left open if not used.
TDO	M5	O	JTAG test data out. It can be left open if not used.
TMS	L4	I	JTAG test mode select. It can be left open if not used.
TRSTB	J3	I	JTAG test reset. Must be tied to GND to hold the JTAG state machine status reset if the JTAG port is not used.
TXENABLE	K5	I	To enable analog output data transmission, set <i>sif_txenable</i> in register <i>config3</i> to "1" or pull CMOS TXENABLE pin to high. Transmit enable active high input. Internal pull-down. To disable analog output, set <i>sif_txenable</i> to "0" and pull CMOS TXENABLE pin to low. The DAC output is forced to midscale. It can be left open if not used.
TESTMODE	K3	O	This pin is used for factory testing. Internal pull-down. It can be left open if not used.
VDDADAC33	D10, E10, H10, J10,	I	Analog supply voltage. (3.3V)
VDDAPLL18	B10, B9	I	PLL analog supply voltage. (1.8V)
VDDAREF18	C10, K10	I	Analog reference supply voltage (1.8V)

**Pin Functions (continued)**

PIN		I/O	DESCRIPTION
NAME	NUMBER		
VDDCLK09	A8, B8	I	Internal clock buffer supply voltage (0.9V). It is recommended to isolate this supply from VDDDIG09.
VDDDAC09	D9, E9, F9, G9, H9, J9	I	DAC core supply voltage. (0.9V). It is recommended to isolate this supply from VDDDIG09.
VDDDIG09	J7, J6, D5, J5, D4, E4, F4, G4, H4, J4, D3	I	Digital supply voltage. (0.9V). It is recommended to isolate this supply from VDDCLK09 and VDDDAC09.
VDDIO18	K7, K6	I	Supply voltage for all digital I/O and CMOS I/O. (1.8V)
VDDR18	F2, G2	I	Supply voltage for SerDes (1.8V)
VDDS18	C7, C6	I	Supply voltage for LVDS SYNCBP/N (1.8V)
VDDT09	F3, G3	I	Supply voltage for SerDes termination (0.9V)
VQPS18	D7, D6	I	Fuse supply voltage. This supply pin is also used for factory fuse programming. Connect to 1.8V.
VSENSE	C4	I/O	Analog test pin for on chip parametric. It can be left open if not used.

## 6 Specifications

### 6.1 Absolute Maximum Ratings

 over operating free-air temperature range (unless otherwise noted)<sup>(1)</sup>

		MIN	MAX	UNIT
Supply voltage <sup>(2)</sup>	VDDDAC09, VDDDIG09	-0.3	1.3	V
	VDDCLK09	-0.3	1.3	V
	VDDT09	-0.3	1.3	V
	VDDR18, VDDIO18, VDDS18, VQPS18	-0.3	2.45	V
	VDDAPLL18, VDDAREF18	-0.3	2.45	V
	VDDADAC33	-0.3	4.0	V
Pin voltage <sup>(2)</sup>	RX[7..0]P/N	-0.5 V	VDDT09 + 0.5 V	V
	SDENB, SCLK, SDIO, SDO, TXENA, ALARM, RESETB, SLEEP, TMS, TCLK, TDI, TDO, TRSTB, TESTMODE, SYNC_N_AB, SYNC_N_CD	-0.5 V	VDDIO18 + 0.5 V	V
	DACCLKP/N, SYSREFP/N	-0.5 V	VDDAPLL18 + 0.5 V	V
	SYNCBP/N	-0.5 V	VDDS18 + 0.5 V	V
	LPF	-0.5 V	VDDAPLL18 + 0.5 V	V
	IOUTAP/N, IOUTBP/N, IOUTCP/N, IOUTDP/N	-0.5 V	1.0 V	V
	RBIAS, EXTIO, ATEST	-0.5 V	VDDAREF18 + 0.5 V	V
	IFORCE, VSENSE	-0.5 V	VDDDIG09 + 0.5 V	V
AMUX1, AMUX0	-0.5 V	VDDT09 + 0.5 V	V	
Peak input current (any input)			20	mA
Peak total input current (all inputs)			-30	mA
Absolute maximum junction temperature T <sub>J</sub>			150	°C
Operating free-air temperature range, T <sub>A</sub> : DAC37J82/DAC38J82		-40	85	°C

- (1) Stresses beyond those listed under absolute maximum ratings may cause permanent damage to the device. These are stress ratings only and functional operation of these or any other conditions beyond those indicated under "recommended operating conditions" is not implied. Exposure to absolute-maximum-rated conditions for extended periods may affect device reliability.

- (2) Measured with respect to GND.

### 6.2 Handling Ratings

		MIN	MAX	UNIT
T <sub>stg</sub>	Storage temperature range	-65	150	°C

### 6.3 Recommended Operating Conditions

		MIN	NOM	MAX	UNIT
T <sub>J</sub>	Recommended operating junction temperature <sup>(1)</sup>			105	°C
	Maximum rated operating junction temperature	125			°C
T <sub>A</sub>	Recommended free-air temperature	-40	25	85	°C

(1) Prolonged use at this junction temperature may increase the device failure-in-time (FIT) rate.

### 6.4 Thermal Information

THERMAL CONDUCTIVITY <sup>(1)</sup>		DAC3xJ82			UNIT
		AAV (144 PINS)			
R <sub>θJA</sub>	Theta junction-to-ambient (still air)	31.4			°C/W
R <sub>θJB</sub>	Theta junction-to-board	12.6			
R <sub>θJC</sub>	Theta junction-to-case, top	1.8			
ψ <sub>JT</sub>	Psi junction-to-top of package	0.2			
ψ <sub>JB</sub>	Psi junction-to-bottom of package	12			

(1) Air flow or heat sinking reduces θ<sub>JA</sub> and may be required for sustained operation at 85° and maximum operating conditions.

### 6.5 DC Electrical Characteristics

Typical values at T<sub>A</sub> = 25°C, full temperature range is T<sub>MIN</sub> = -40°C to T<sub>MAX</sub> = 85°C, nominal supplies, unless otherwise noted.

PARAMETER	TEST CONDITIONS	DAC37J82			DAC38J82			UNIT
		MIN	TYP	MAX	MIN	TYP	MAX	
<b>Resolution</b>		16			16			Bits
<b>DC ACCURACY</b>								
DNL	Differential nonlinearity	1 LSB = IOUT <sub>FS</sub> /2 <sup>16</sup>			±4			LSB
INL	Integral nonlinearity				±6			LSB
<b>ANALOG OUTPUT</b>								
	Coarse gain linearity				±0.04			LSB
	Offset error	Mid code offset			±0.001			%FSR
	Gain error	With external reference			±2			%FSR
		With internal reference			±2			
	Gain mismatch	With internal reference			±2			%FSR
	Full scale output current				20 30			mA
	Output compliance range				-0.5 0.6			V
	Output resistance	300			300			kΩ
	Output capacitance	5			5			pF
<b>REFERENCE OUTPUT</b>								
V <sub>REF</sub>	Reference output voltage	0.9			0.9			V
	Reference output current <sup>(1)</sup>	100			100			nA
<b>REFERENCE INPUT</b>								
V <sub>EXTIO</sub>	Input voltage range	External reference mode			0.1 0.9 1			V
	Input resistance				1			MΩ
	Input capacitance				50			pF
<b>TEMPERATURE COEFFICIENTS</b>								
	Offset drift				±1			Ppm/°C
	Gain drift	With external reference			±15			ppm/°C
		With internal reference			±30			
	Reference voltage drift				±8			ppm/°C

(1) Use an external buffer amplifier with high impedance input to drive any external load.

**DC Electrical Characteristics (continued)**

 Typical values at  $T_A = 25^\circ\text{C}$ , full temperature range is  $T_{\text{MIN}} = -40^\circ\text{C}$  to  $T_{\text{MAX}} = 85^\circ\text{C}$ , nominal supplies, unless otherwise noted.

PARAMETER	TEST CONDITIONS	DAC37J82			DAC38J82			UNIT
		MIN	TYP	MAX	MIN	TYP	MAX	
<b>POWER SUPPLY</b>								
VDDADAC33		3.15	3.3	3.45	3.15	3.3	3.45	V
VDDAPLL18, VDDAREF18, VDDS18, VQPS18, VDDR18		1.71	1.8	1.89	1.71	1.8	1.89	V
VDDIO18		1.71	1.8	1.89	1.71	1.8	1.89	V
VDDDIG09, VDDDAC09, VDDCLK09, VDDT09		0.85	0.9	0.95	0.85	0.9	0.95	V
PSRR	Power Supply Rejection Ratio	DC tested			±0.2			%FSR/V
<b>POWER CONSUMPTION</b>								
$I_{\text{VDDADAC33}}$	Analog supply current	MODE 1:(DAC38J82)			-	64	80	mA
$I_{\text{VDDDIG09}}$	Digital supply current	$f_{\text{DAC}}=2.46\text{GSPS}$ , 2x interpolation,			-	628	800	
$I_{\text{VDDDAC09}}$	DAC supply current	NCO on, QMC on, inverse sinc on,			-	13	25	
$I_{\text{VDDCLK09}}$	Clock supply current	GDC off, PAP off, PLL on, LMF=421,			-	86	120	
$I_{\text{VDDT09}}$	SerDes core supply current	SerDes rate = 12.3GSPS, 20mA FS output, IF=150MHz.			-	168	250	
$I_{\text{VDDR18}}$	SerDes analog supply current				-	18	35	
$I_{\text{VDD18}}$	Other 1.8V supply current				-	53	80	
P	Power dissipation				-	1144	1290 <sup>(2)</sup>	
$I_{\text{VDDADAC33}}$	Analog supply current	MODE 2: (DAC37J82)			64	64	mA	
$I_{\text{VDDDIG09}}$	Digital supply current	$f_{\text{DAC}}=1.6\text{GSPS}$ , 2x interpolation,			418	418		
$I_{\text{VDDDAC09}}$	DAC supply current	NCO on, QMC on, invsinc on,			10	10		
$I_{\text{VDDCLK09}}$	Clock supply current	GDC off, PAP off, PLL on, LMF=421,			57	57		
$I_{\text{VDDT09}}$	SerDes core supply current	SerDes rate = 8GSPS, 20mA FS output, IF=150MHz.			139	139		
$I_{\text{VDDR18}}$	SerDes analog supply current				12	12		
$I_{\text{VDD18}}$	Other 1.8V supply current				50	50		
P	Power dissipation				884	884		mW
$I_{\text{VDDADAC33}}$	Analog supply current	MODE 3:			64	64	mA	
$I_{\text{VDDDIG09}}$	Digital supply current	$f_{\text{DAC}}=1.47456\text{GSPS}$ , 2x interpolation,			363	363		
$I_{\text{VDDDAC09}}$	DAC supply current	NCO on, QMC off, invsinc off, GDC off,			10	10		
$I_{\text{VDDCLK09}}$	Clock supply current	PAP off, PLL off, LMF=421, SerDes rate = 7.3728GSPS, 20mA FS output, IF=150MHz.			50	50		
$I_{\text{VDDT09}}$	SerDes core supply current				135	135		
$I_{\text{VDDR18}}$	SerDes analog supply current				12	12		
$I_{\text{VDD18}}$	Other 1.8V supply current				30	30		
P	Power dissipation				789	789		mW
$I_{\text{VDDADAC33}}$	Analog supply current	MODE 4:			64	64	mA	
$I_{\text{VDDDIG09}}$	Digital supply current	$f_{\text{DAC}}=1.47456\text{GSPS}$ , 4x interpolation,			312	312		
$I_{\text{VDDDAC09}}$	DAC supply current	NCO on, QMC off, invsinc off, GDC off, PAP off, PLL off, LMF=222,			10	10		
$I_{\text{VDDCLK09}}$	Clock supply current	SerDes rate = 7.3728GSPS, 20mA FS output, IF=150MHz.			50	50		
$I_{\text{VDDT09}}$	SerDes core supply current				76	76		
$I_{\text{VDDR18}}$	SerDes analog supply current				12	12		
$I_{\text{VDD18}}$	Other 1.8V supply current				30	30		
P	Power dissipation				690	690		mW

(2) The MAX power limit is set separately which is NOT equal to the power consumption when all of the power supplies are at the MAX current.



## DC Electrical Characteristics (continued)

 Typical values at  $T_A = 25^\circ\text{C}$ , full temperature range is  $T_{\text{MIN}} = -40^\circ\text{C}$  to  $T_{\text{MAX}} = 85^\circ\text{C}$ , nominal supplies, unless otherwise noted.

PARAMETER	TEST CONDITIONS	DAC37J82			DAC38J82			UNIT
		MIN	TYP	MAX	MIN	TYP	MAX	
$I_{\text{VDDADAC33}}$	Analog supply current		13			13		mA
$I_{\text{VDDDIG09}}$	Digital supply current		263			263		
$I_{\text{VDDDAC09}}$	DAC supply current		8			8		
$I_{\text{VDDCLK09}}$	Clock supply current		50			50		
$I_{\text{VDDT09}}$	SerDes core supply current		76			76		
$I_{\text{VDDR18}}$	SerDes analog supply current		12			12		
$I_{\text{VDD18}}$	Other 1.8V supply current		26			26		
P	Power dissipation		469			469	mW	
$I_{\text{VDDADAC33}}$	Analog supply current		64			64		mA
$I_{\text{VDDDIG09}}$	Digital supply current		257			257		
$I_{\text{VDDDAC09}}$	DAC supply current		8			8		
$I_{\text{VDDCLK09}}$	Clock supply current		36			36		
$I_{\text{VDDT09}}$	SerDes core supply current		85			85		
$I_{\text{VDDR18}}$	SerDes analog supply current		15			15		
$I_{\text{VDD18}}$	Other 1.8V supply current		50			50		
P	Power dissipation		676			676	mW	
$I_{\text{VDDADAC33}}$	Analog supply current		64			64		mA
$I_{\text{VDDDIG09}}$	Digital supply current		256			256		
$I_{\text{VDDDAC09}}$	DAC supply current		8			8		
$I_{\text{VDDCLK09}}$	Clock supply current		35			35		
$I_{\text{VDDT09}}$	SerDes core supply current		85			85		
$I_{\text{VDDR18}}$	SerDes analog supply current		15			15		
$I_{\text{VDD18}}$	Other 1.8V supply current		29			29		
P	Power dissipation		636			636	mW	
$I_{\text{VDDADAC33}}$	Analog supply current		64			64		mA
$I_{\text{VDDDIG09}}$	Digital supply current		195			195		
$I_{\text{VDDDAC09}}$	DAC supply current		4			4		
$I_{\text{VDDCLK09}}$	Clock supply current		22			22		
$I_{\text{VDDT09}}$	SerDes core supply current		119			119		
$I_{\text{VDDR18}}$	SerDes analog supply current		11			11		
$I_{\text{VDD18}}$	Other 1.8V supply current		25			25		
P	Power dissipation		582			582	mW	
$I_{\text{VDDADAC33}}$	Analog supply current		64			64		mA
$I_{\text{VDDDIG09}}$	Digital supply current		311			311		
$I_{\text{VDDDAC09}}$	DAC supply current		10			10		
$I_{\text{VDDCLK09}}$	Clock supply current		42			42		
$I_{\text{VDDT09}}$	SerDes core supply current		165			165		
$I_{\text{VDDR18}}$	SerDes analog supply current		18			18		
$I_{\text{VDD18}}$	Other 1.8V supply current		29			29		
P	Power dissipation		771			771	mW	
$I_{\text{VDDADAC33}}$	Analog supply current		5			5		mA
$I_{\text{VDDDIG09}}$	Digital supply current		76			76		
$I_{\text{VDDDAC09}}$	DAC supply current		1			1		
$I_{\text{VDDCLK09}}$	Clock supply current		1			1		
$I_{\text{VDDT09}}$	SerDes core supply current		9			9		
$I_{\text{VDDR18}}$	SerDes analog supply current		0			0		
$I_{\text{VDD18}}$	Other 1.8V supply current		10			10		
P	Power dissipation		112			112	mW	

## 6.6 Digital Electrical Characteristics

Typical values at  $T_A = 25^\circ\text{C}$ , full temperature range is  $T_{\text{MIN}} = -40^\circ\text{C}$  to  $T_{\text{MAX}} = 85^\circ\text{C}$ , nominal supplies, unless otherwise noted.

PARAMETER		TEST CONDITIONS	DAC37J82			DAC38J82			UNIT
			MIN	TYP	MAX	MIN	TYP	MAX	
<b>CML SERDES INPUTS: RX[7:0]P/N</b>									
$V_{\text{DIFF}}$	Receiver input amplitude		50		1200	50		1200	mV
$V_{\text{COM}}$	Input common mode (TERM=111)			600			600		mV
	Input common mode (TERM=001)			700			700		
	Input common mode (TERM=100)			0			0		
	Input common mode (TERM=101)			250			250		
$Z_{\text{DIFF}}$	Internal differential termination		85	100	115	85	100	115	$\Omega$
$f_{\text{DATA}}$	Serdes bit rate		0.78125		12.5	0.78125		12.5	Gbps
<b>LVPECL INPUTS: SYSREFP/N</b>									
$V_{\text{COM}}$	Input common mode voltage			0.5			0.5		V
$V_{\text{IDPP}}$	Differential input peak-to-peak voltage		400	800		400	800		mV
$Z_T$	Internal termination			100			100		$\Omega$
$C_L$	Input capacitance			2			2		pF
<b>LVPECL INPUTS: DACCLKP/N</b>									
$V_{\text{COM}}$	Input common mode voltage			0.5			0.5		V
$V_{\text{IDPP}}$	Differential input peak-to-peak voltage		400	800		400	800		mV
$Z_T$	Internal termination			100			100		$\Omega$
$C_L$	Input capacitance			2			2		pF
	Duty cycle		40%		60%	40%		60%	
$f_{\text{DACCLK}}$	DACCLKP/N Input Frequency				1.6			2.5	GHz
<b>LVDS OUTPUTS: SYNCBP/N</b>									
$V_{\text{COM}}$	Output common mode voltage			1.2			1.2		V
$Z_T$	Internal termination			100			100		$\Omega$
$V_{\text{OD}}$	Differential output voltage swing			0.5			0.5		V
<b>CMOS INTERFACE: SDENB, SCLK, SDIO, SDO, TXENA, ALARM, RESETB, SLEEP, TMS, TCLK, TDI, TDO, TRSTB, TESTMODE, SYNC_N_AB, SYNC_N_CD</b>									
$V_{\text{IH}}$	High-level input voltage			$0.7 \times \text{VDDIO1}$		$0.7 \times \text{VDDIO1}$			V
$V_{\text{IL}}$	Low-level input voltage			$0.3 \times \text{VDDIO1}$		$0.3 \times \text{VDDIO1}$			V
$I_{\text{IH}}$	High-level input current		-40	40		-40	40		$\mu\text{A}$
$I_{\text{IL}}$	Low-level input current		-40	40		-40	40		$\mu\text{A}$
$C_I$	CMOS Input capacitance			2			2		pF
$V_{\text{OH}}$	ALARM, SDO, SDIO, TDO	$I_{\text{load}} = -100 \mu\text{A}$		$\text{VDDIO1}$		$\text{VDDIO1}$			V
		$I_{\text{load}} = -2 \text{ mA}$		$0.8 \times \text{VDDIO1}$		$0.8 \times \text{VDDIO1}$			
$V_{\text{OL}}$	ALARM, SDO, SDIO, TDO	$I_{\text{load}} = 100 \mu\text{A}$			0.2		0.2		V
		$I_{\text{load}} = 2 \text{ mA}$			0.5		0.5		

## Digital Electrical Characteristics (continued)

Typical values at  $T_A = 25^\circ\text{C}$ , full temperature range is  $T_{\text{MIN}} = -40^\circ\text{C}$  to  $T_{\text{MAX}} = 85^\circ\text{C}$ , nominal supplies, unless otherwise noted.

PARAMETER	TEST CONDITIONS	DAC37J82			DAC38J82			UNIT
		MIN	TYP	MAX	MIN	TYP	MAX	
<b>PHASE LOCKED LOOP</b>								
PLL/VCO operating frequency	pll_vcose1 = '1', pll_vco = '010001'(17), pll_vcoitune = '10', VCO Frequency = 3932.16MHz	Assured			Assured			
	pll_vcose1 = '1', pll_vco = '011111'(31), pll_vcoitune = '10', VCO Frequency = 4120MHz	Assured			Assured			
	pll_vcose1 = '1', pll_vco = '110010'(50), pll_vcoitune = '10', VCO Frequency = 4423.68MHz	Assured			Assured			
	pll_vcose1 = '0', pll_vco = '001101'(13), pll_vcoitune = '11', VCO Frequency = 4608MHz	Assured			Assured			
	pll_vcose1 = '0', pll_vco = '011010'(26), pll_vcoitune = '11', VCO Frequency = 4800MHz	Assured			Assured			
	pll_vcose1 = '0', pll_vco = '100001'(33), pll_vcoitune = '11', VCO Frequency = 4915.2MHz	Assured			Assured			
	pll_vcose1 = '0', pll_vco = '100110'(38), pll_vcoitune = '11', VCO Frequency = 5000MHz	Assured			Assured			

## 6.7 AC Electrical Characteristics

Typical values at  $T_A = 25^\circ\text{C}$ , full temperature range is  $T_{\text{MIN}} = -40^\circ\text{C}$  to  $T_{\text{MAX}} = 85^\circ\text{C}$ , nominal supplies, unless otherwise noted.

PARAMETER	TEST CONDITIONS / COMMENTS	DAC37J82			DAC38J82			UNIT
		MIN	TYP	MAX	MIN	TYP	MAX	
<b>ANALOG OUTPUT <sup>(1)</sup></b>								
$f_{\text{DAC}}$	Maximum DAC rate	4x or higher interpolation			1600			MSPS
		2x interpolation			1600			
		1x interpolation			1230			
Digital latency (F=2, 2x interpolation)	No interpolation, FIFO off, Mixer off, QMC off, Inverse sinc off	11			11			DAC clock cycles
	2x Interpolation	83			83			
	4x Interpolation	211			211			
	8x Interpolation	483			483			
	16x Interpolation	1051			1051			
	NCO	48			48			
	QMC	32			32			
	Inverse Sinc	36			36			
	PA Protection ( <i>pap_dlyten_sel</i> = "0")	68			68			
	Dithering	0			0			
	Complex Summation	0			0			
	Coarse Fractional Delay	51			51			
	Fine Fractional Delay	52			52			

(1) Measured single ended into 50  $\Omega$  load.

**AC Electrical Characteristics (continued)**

 Typical values at  $T_A = 25^\circ\text{C}$ , full temperature range is  $T_{\text{MIN}} = -40^\circ\text{C}$  to  $T_{\text{MAX}} = 85^\circ\text{C}$ , nominal supplies, unless otherwise noted.

PARAMETER	TEST CONDITIONS / COMMENTS	DAC37J82			DAC38J82			UNIT
		MIN	TYP	MAX	MIN	TYP	MAX	
<b>AC PERFORMANCE <sup>(2)</sup></b>								
SFDR	Spurious free dynamic (0 to $f_{\text{DAC}}/2$ )	$f_{\text{DAC}} = 2.5 \text{ GSPS}, f_{\text{OUT}} = 20 \text{ MHz}, 0 \text{ dBFS}$	-			79		dBc
		$f_{\text{DAC}} = 2.5 \text{ GSPS}, f_{\text{OUT}} = 70 \text{ MHz}, 0 \text{ dBFS}$	-			78		
		$f_{\text{DAC}} = 2.5 \text{ GSPS}, f_{\text{OUT}} = 150 \text{ MHz}, 0 \text{ dBFS}$	-			72		
		$f_{\text{DAC}} = 2.5 \text{ GSPS}, f_{\text{OUT}} = 230 \text{ MHz}, 0 \text{ dBFS}$	-			67		
		$f_{\text{DAC}} = 2.5 \text{ GSPS}, f_{\text{OUT}} = 20 \text{ MHz}, -12 \text{ dBFS}$	-			79		
		$f_{\text{DAC}} = 2.5 \text{ GSPS}, f_{\text{OUT}} = 70 \text{ MHz}, -12 \text{ dBFS}$	-			75		
		$f_{\text{DAC}} = 2.5 \text{ GSPS}, f_{\text{OUT}} = 150 \text{ MHz}, -12 \text{ dBFS}$	-			70		
		$f_{\text{DAC}} = 2.5 \text{ GSPS}, f_{\text{OUT}} = 230 \text{ MHz}, -12 \text{ dBFS}$	-			65		
		$f_{\text{DAC}} = 1.6 \text{ GSPS}, f_{\text{OUT}} = 20 \text{ MHz}, 0 \text{ dBFS}$		81		81		
		$f_{\text{DAC}} = 1.6 \text{ GSPS}, f_{\text{OUT}} = 70 \text{ MHz}, 0 \text{ dBFS}$		77		77		
		$f_{\text{DAC}} = 1.6 \text{ GSPS}, f_{\text{OUT}} = 150 \text{ MHz}, 0 \text{ dBFS}$		72		72		
		$f_{\text{DAC}} = 1.6 \text{ GSPS}, f_{\text{OUT}} = 230 \text{ MHz}, 0 \text{ dBFS}$		68		68		
		$f_{\text{DAC}} = 1.6 \text{ GSPS}, f_{\text{OUT}} = 20 \text{ MHz}, -12 \text{ dBFS}$		76		76		
		$f_{\text{DAC}} = 1.6 \text{ GSPS}, f_{\text{OUT}} = 70 \text{ MHz}, -12 \text{ dBFS}$		72		72		
		$f_{\text{DAC}} = 1.6 \text{ GSPS}, f_{\text{OUT}} = 150 \text{ MHz}, -12 \text{ dBFS}$		67		67		
$f_{\text{DAC}} = 1.6 \text{ GSPS}, f_{\text{OUT}} = 230 \text{ MHz}, -12 \text{ dBFS}$		64		64				
IMD3	Third-order two-tone intermodulation distortion Each tone at $-6 \text{ dBFS}$	$f_{\text{DAC}} = 2.5 \text{ GSPS}, f_{\text{OUT}} = 70 \pm 0.5 \text{ MHz}$	-			83		dBc
		$f_{\text{DAC}} = 2.5 \text{ GSPS}, f_{\text{OUT}} = 150 \pm 0.5 \text{ MHz}$	-			75		
		$f_{\text{DAC}} = 2.5 \text{ GSPS}, f_{\text{OUT}} = 230 \pm 0.5 \text{ MHz}$	-			70		
		$f_{\text{DAC}} = 2.0 \text{ GSPS}, f_{\text{OUT}} = 70 \pm 0.5 \text{ MHz}$	-			86		
		$f_{\text{DAC}} = 2.0 \text{ GSPS}, f_{\text{OUT}} = 150 \pm 0.5 \text{ MHz}$	-			78		
		$f_{\text{DAC}} = 2.0 \text{ GSPS}, f_{\text{OUT}} = 230 \pm 0.5 \text{ MHz}$	-			73		
		$f_{\text{DAC}} = 1.6 \text{ GSPS}, f_{\text{OUT}} = 70 \pm 0.5 \text{ MHz}$		83		83		
		$f_{\text{DAC}} = 1.6 \text{ GSPS}, f_{\text{OUT}} = 150 \pm 0.5 \text{ MHz}$		73		73		
$f_{\text{DAC}} = 1.6 \text{ GSPS}, f_{\text{OUT}} = 230 \pm 0.5 \text{ MHz}$		66		66				
NSD	Noise spectral density <sup>(2)</sup> Tone at $-6 \text{ dBFS}$	$f_{\text{DAC}} = 2.5 \text{ GSPS}, f_{\text{OUT}} = 70 \text{ MHz}$	-			-161		dBFS/Hz
		$f_{\text{DAC}} = 2.5 \text{ GSPS}, f_{\text{OUT}} = 150 \text{ MHz}$	-			-159		
		$f_{\text{DAC}} = 2.5 \text{ GSPS}, f_{\text{OUT}} = 230 \text{ MHz}$	-			-157		
		$f_{\text{DAC}} = 2.0 \text{ GSPS}, f_{\text{OUT}} = 70 \text{ MHz}$	-			-161		
		$f_{\text{DAC}} = 2.0 \text{ GSPS}, f_{\text{OUT}} = 150 \text{ MHz}$	-			-160		
		$f_{\text{DAC}} = 2.0 \text{ GSPS}, f_{\text{OUT}} = 230 \text{ MHz}$	-			-158		
		$f_{\text{DAC}} = 1.6 \text{ GSPS}, f_{\text{OUT}} = 70 \text{ MHz}$		-161		-161		
		$f_{\text{DAC}} = 1.6 \text{ GSPS}, f_{\text{OUT}} = 150 \text{ MHz}$		-159		-159		
$f_{\text{DAC}} = 1.6 \text{ GSPS}, f_{\text{OUT}} = 230 \text{ MHz}$		-157		-157				
ACLR <sup>(3)</sup>	Adjacent channel leakage ratio, single carrier	$f_{\text{DAC}} = 2.4576 \text{ GSPS}, f_{\text{OUT}} = 70 \text{ MHz}$	-			82		dBc
		$f_{\text{DAC}} = 2.4576 \text{ GSPS}, f_{\text{OUT}} = 150 \text{ MHz}$	-			80		
		$f_{\text{DAC}} = 2.4576 \text{ GSPS}, f_{\text{OUT}} = 230 \text{ MHz}$	-			78		
		$f_{\text{DAC}} = 1.96608 \text{ GSPS}, f_{\text{OUT}} = 70 \text{ MHz}$	-			82		
		$f_{\text{DAC}} = 1.96608 \text{ GSPS}, f_{\text{OUT}} = 150 \text{ MHz}$	-			80		
		$f_{\text{DAC}} = 1.96608 \text{ GSPS}, f_{\text{OUT}} = 230 \text{ MHz}$	-			77		
		$f_{\text{DAC}} = 1.47456 \text{ GSPS}, f_{\text{OUT}} = 70 \text{ MHz}$		82		82		
		$f_{\text{DAC}} = 1.47456 \text{ GSPS}, f_{\text{OUT}} = 150 \text{ MHz}$		80		80		
$f_{\text{DAC}} = 1.47456 \text{ GSPS}, f_{\text{OUT}} = 230 \text{ MHz}$		76		76				
Channel isolation		$f_{\text{DAC}} = 2.5 \text{ GSPS}, f_{\text{OUT}} = 20 \text{ MHz}$	-			93		dBc
		$f_{\text{DAC}} = 1.6 \text{ GSPS}, f_{\text{OUT}} = 20 \text{ MHz}$		93		93		

 (2) 2:1 transformer output termination, 50  $\Omega$  doubly terminated load.

(3) Single carrier, W-CDMA with 3.84 MHz BW, 5-MHz spacing, centered at IF. TESTMODEL 1, 10 ms

## 6.8 Timing Requirements

Typical values at  $T_A = 25^\circ\text{C}$ , full temperature range is  $T_{\text{MIN}} = -40^\circ\text{C}$  to  $T_{\text{MAX}} = 85^\circ\text{C}$ , nominal supplies, unless otherwise noted.

PARAMETER	TEST CONDITIONS	DAC37J82			DAC38J82			UNIT
		MIN	TYP	MAX	MIN	TYP	MAX	
<b>DIGITAL INPUT TIMING SPECIFICATIONS</b>								
<b>TIMING SYSREF INPUT: DACCLKP/N RISING EDGE LATCHING</b>								
$t_{\text{s}}(\text{SYSREF})$	Setup time, SYSREFP/N valid to rising edge of DACCLKP/N		50		50			ps
$t_{\text{h}}(\text{SYSREF})$	Hold time, SYSREF/N valid after rising edge of DACCLKP/N		50		50			ps
<b>TIMING SERIAL PORT</b>								
$t_{\text{s}}(\text{SDENB})$	Setup time, SDENB to rising edge of SCLK		20		20			ns
$t_{\text{s}}(\text{SDIO})$	Setup time, SDIO valid to rising edge of SCLK		10		10			ns
$t_{\text{h}}(\text{SDIO})$	Hold time, SDIO valid to rising edge of SCLK		5		5			ns
$t_{\text{f}}(\text{SCLK})$	Period of SCLK	Register config7 read (temperature sensor read)	1		1			$\mu\text{s}$
		All other registers	100		100			ns
$t_{\text{d}}(\text{Data})$	Data output delay after falling edge of SCLK		10		10			ns
$t_{\text{RESET}}$	Minimum RESETB pulsewidth		25		25			ns
<b>ANALOG OUTPUT <sup>(1)</sup></b>								
$t_{\text{s}}(\text{DAC})$	Output settling time to 0.1%	Transition: Code 0x0000 to 0xFFFF	10		10			ns
Power-up Time	DAC wake-up time	IOUT current settling to 1% of IOUT <sub>FS</sub> from deep sleep	90		90			$\mu\text{s}$
	DAC sleep time	IOUT current settling to less than 1% of IOUT <sub>FS</sub> in deep sleep	90		90			

(1) Measured single ended into 50  $\Omega$  load.

## 6.9 Switching Characteristics

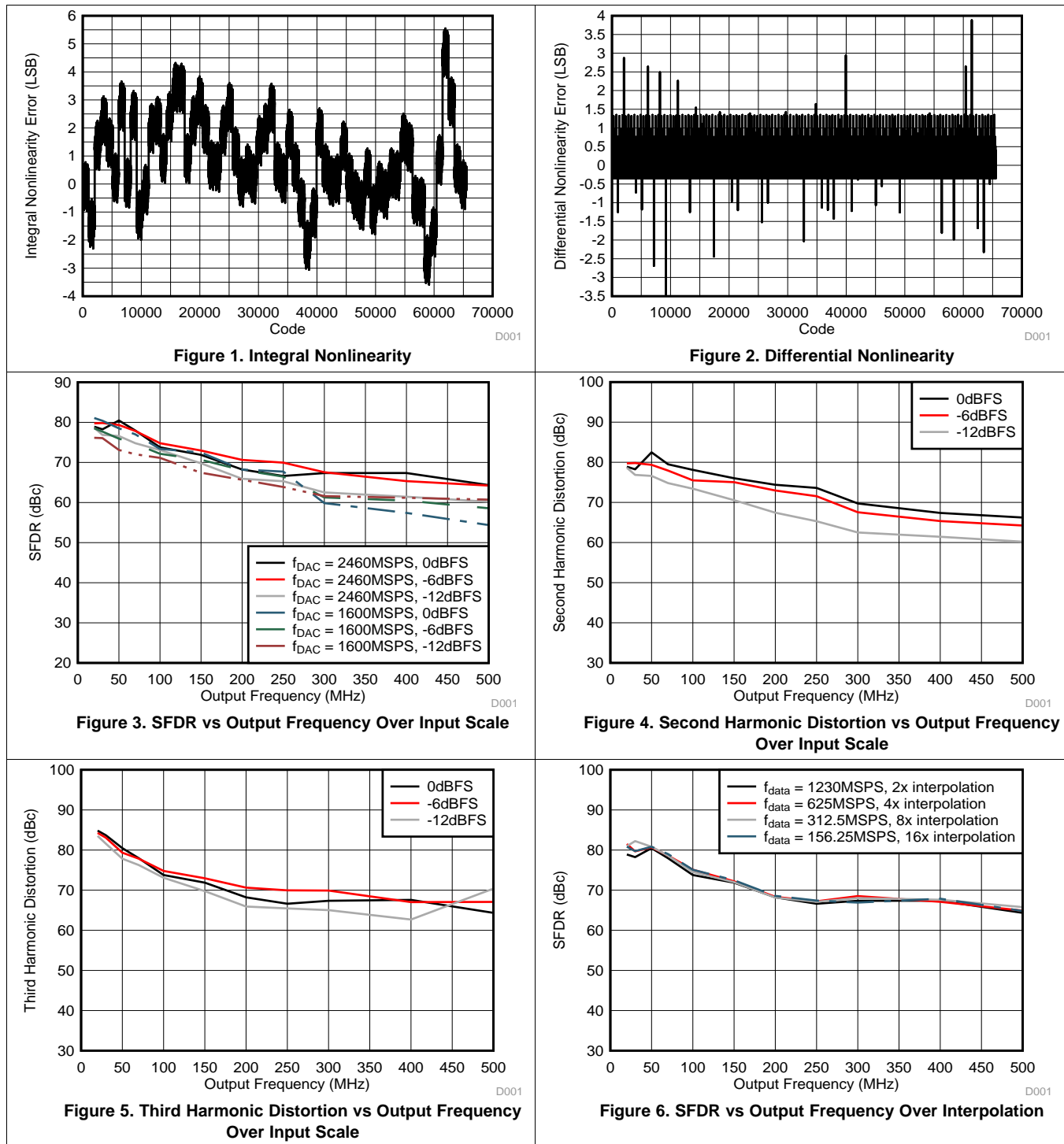
Typical values at  $T_A = 25^\circ\text{C}$ , full temperature range is  $T_{\text{MIN}} = -40^\circ\text{C}$  to  $T_{\text{MAX}} = 85^\circ\text{C}$ , nominal supplies, unless otherwise noted.

PARAMETER	TEST CONDITIONS	DAC37J82			DAC38J82			UNIT	
		MIN	TYP	MAX	MIN	TYP	MAX		
<b>ANALOG OUTPUT <sup>(1)</sup></b>									
$t_{\text{pd}}$	Output propagation delay	DAC outputs are updated on the falling edge of DAC clock. Does not include Digital Latency (see below).			2		2		ns
$t_{\text{r}}(\text{IOUT})$	Output rise time 10% to 90%		50		50			ps	
$t_{\text{f}}(\text{IOUT})$	Output fall time 90% to 10%		50		50			ps	

(1) Measured single ended into 50  $\Omega$  load.

### 6.10 Typical Characteristics

Unless otherwise noted, all plots are at  $T_A = 25^\circ\text{C}$ , nominal supply voltages,  $f_{\text{DAC}} = 2460\text{MSPS}$ , 2x interpolation, 0dBFS digital input, 20mA full scale output current with 2:1 transformer, LMF = 421 and PLL is disabled.



Typical Characteristics (continued)

Unless otherwise noted, all plots are at  $T_A = 25^\circ\text{C}$ , nominal supply voltages,  $f_{\text{DAC}} = 2460\text{MSPS}$ , 2x interpolation, 0dBFS digital input, 20mA full scale output current with 2:1 transformer, LMF = 421 and PLL is disabled.

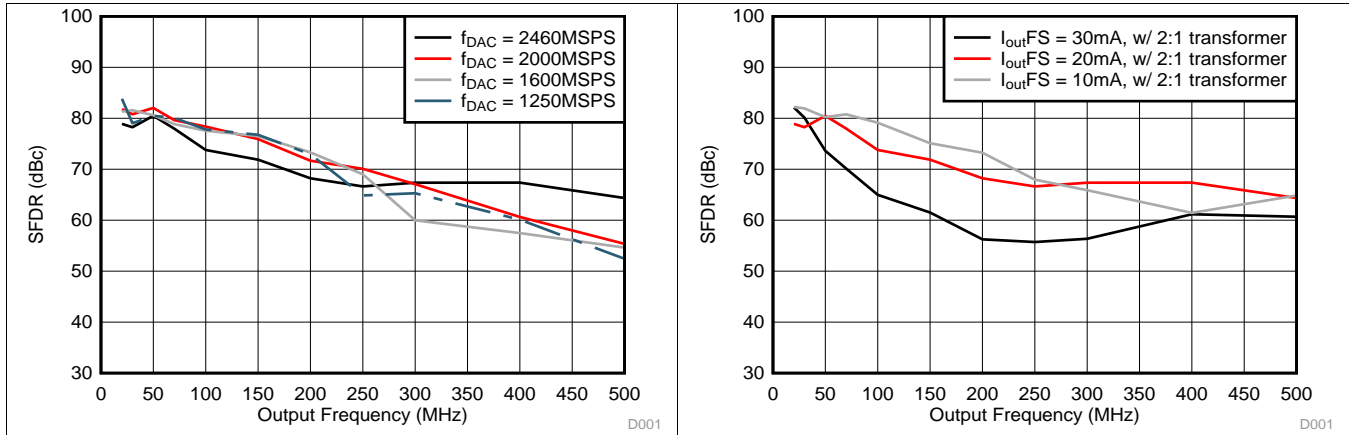
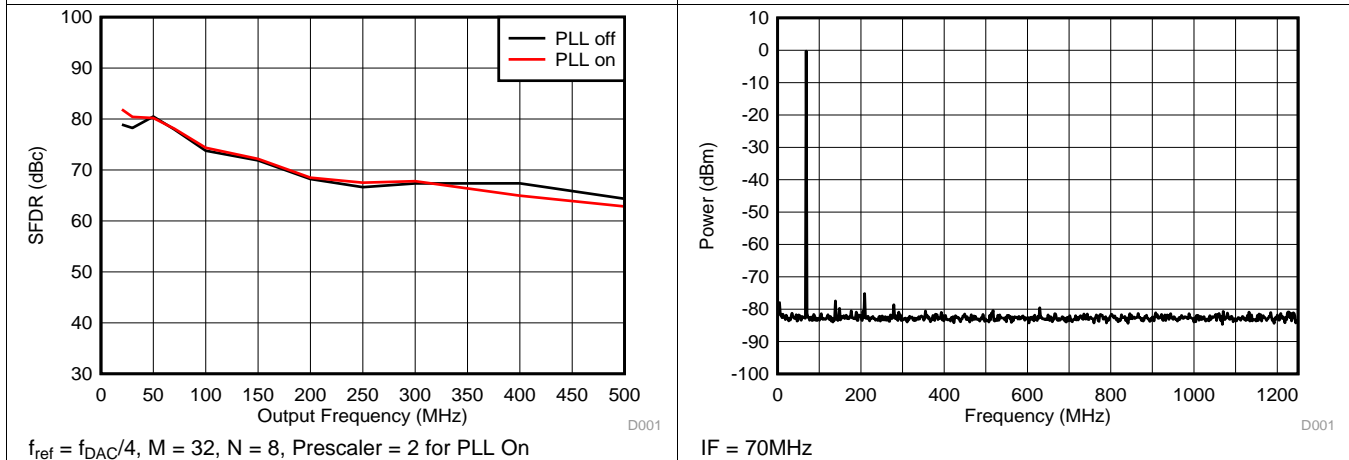


Figure 7. SFDR vs Output Frequency Over  $f_{\text{DAC}}$

Figure 8. SFDR vs Output Frequency Over  $I_{\text{outFS}}$



$f_{\text{ref}} = f_{\text{DAC}}/4$ ,  $M = 32$ ,  $N = 8$ , Prescaler = 2 for PLL On

Figure 9. SFDR vs Output Frequency Over Clocking Options

Figure 10. Single Tone Spectral Plot

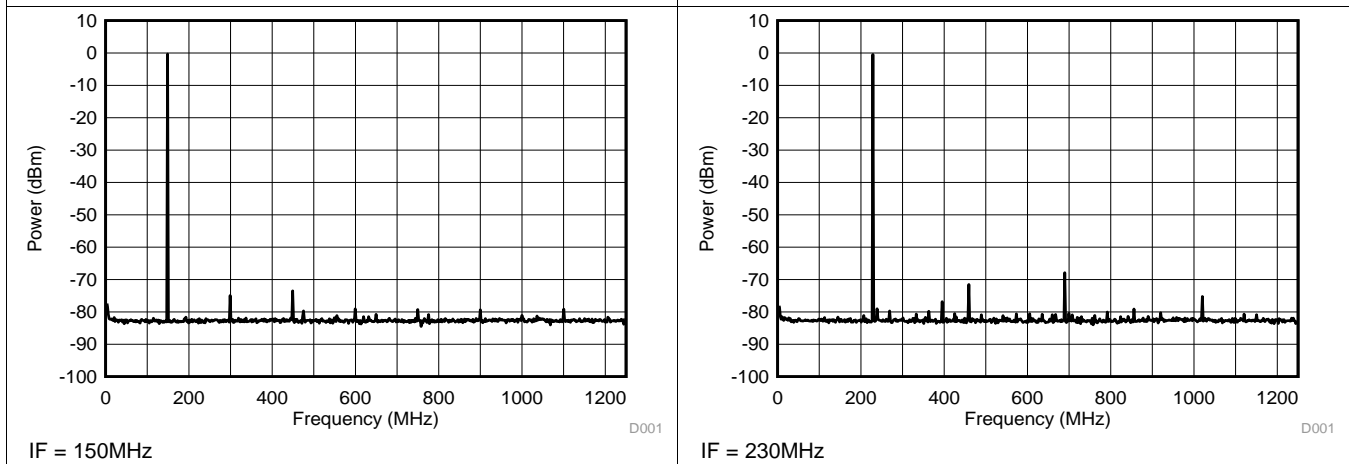


Figure 11. Single Tone Spectral Plot

Figure 12. Single Tone Spectral Plot

Typical Characteristics (continued)

Unless otherwise noted, all plots are at  $T_A = 25^\circ\text{C}$ , nominal supply voltages,  $f_{\text{DAC}} = 2460\text{MSPS}$ , 2x interpolation, 0dBFS digital input, 20mA full scale output current with 2:1 transformer, LMF = 421 and PLL is disabled.

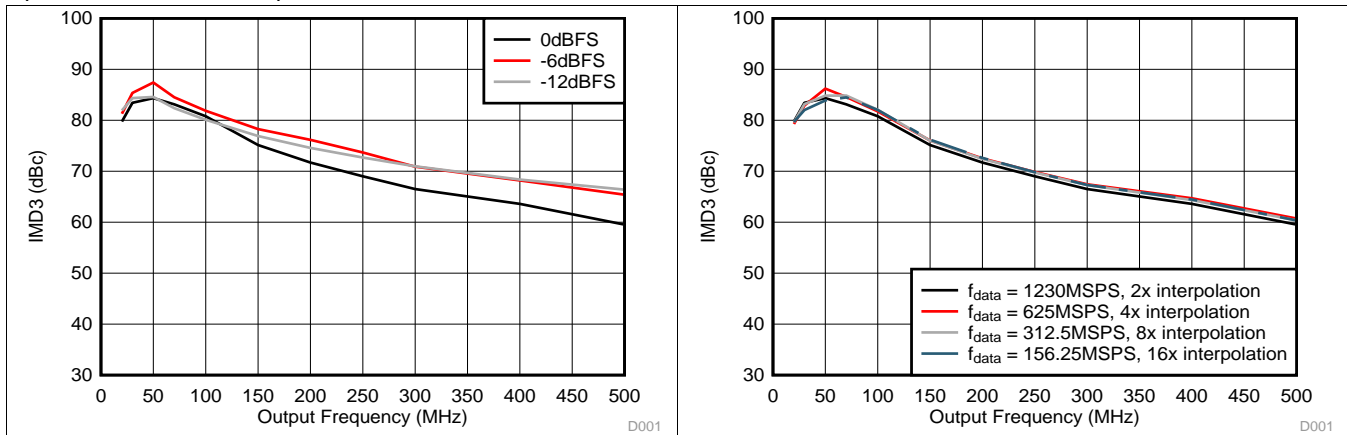


Figure 13. IMD3 vs Output Frequency Over Input Scale

Figure 14. IMD3 vs Output Frequency Over Interpolation

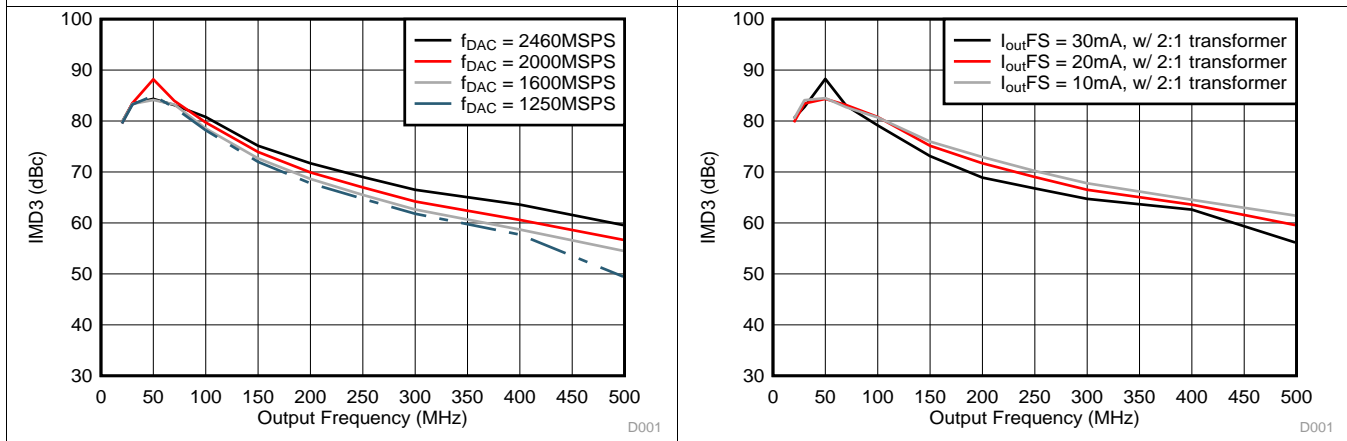
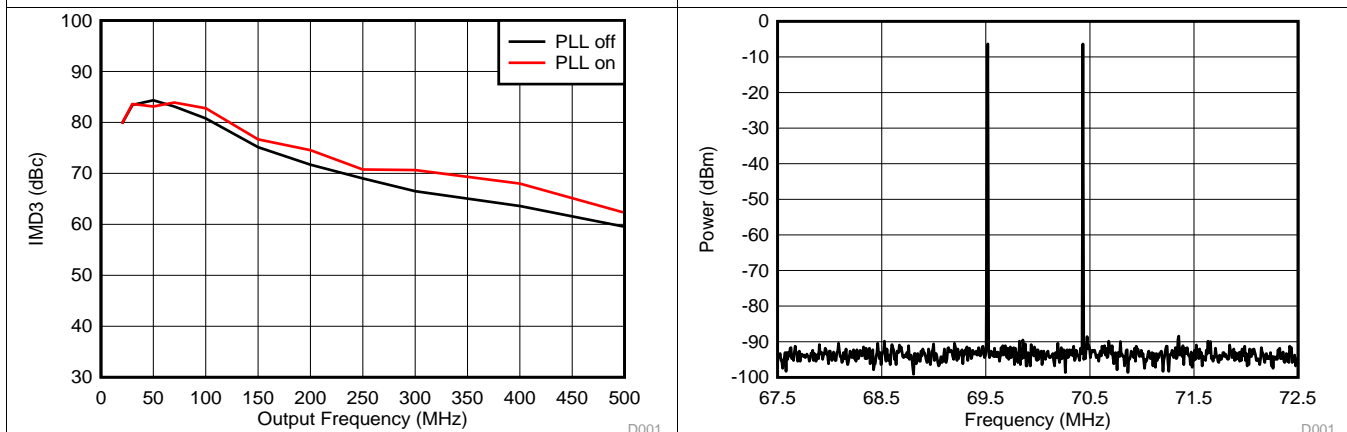


Figure 15. IMD3 vs Output Frequency Over  $f_{\text{DAC}}$

Figure 16. IMD3 vs Output Frequency Over Output Current  $I_{\text{outFS}}$



$f_{\text{ref}} = f_{\text{DAC}}/4$ ,  $M = 32$ ,  $N = 8$ , Prescaler = 2 for PLL On

Figure 17. IMD3 vs Output Frequency Over Clocking Options

Figure 18. Two-tone Spectral Plot



Typical Characteristics (continued)

Unless otherwise noted, all plots are at  $T_A = 25^\circ\text{C}$ , nominal supply voltages,  $f_{\text{DAC}} = 2460\text{MSPS}$ , 2x interpolation, 0dBFS digital input, 20mA full scale output current with 2:1 transformer, LMF = 421 and PLL is disabled.

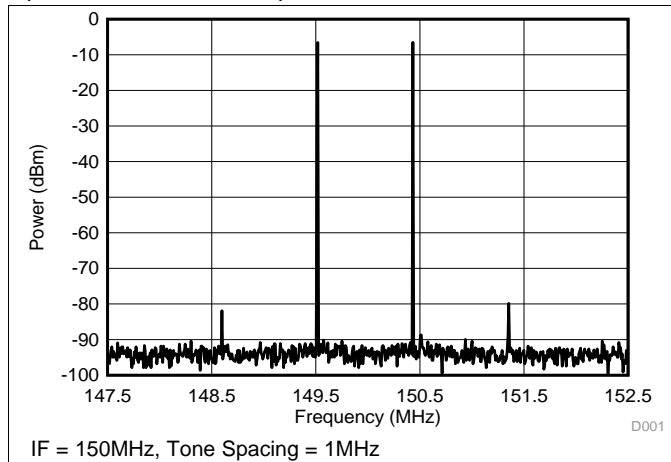


Figure 19. Two-tone Spectral Plot

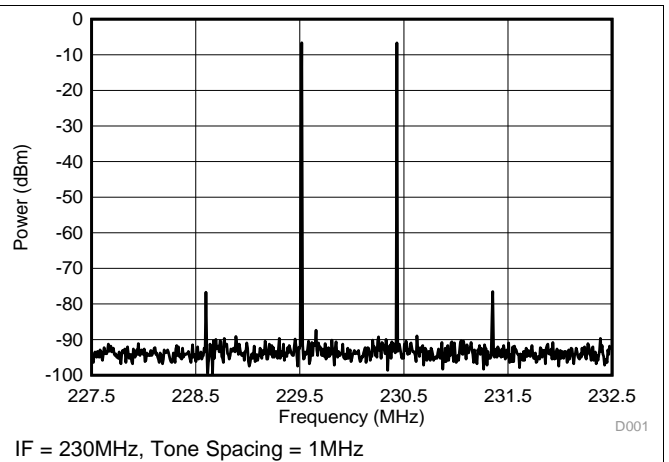


Figure 20. Two-tone Spectral Plot

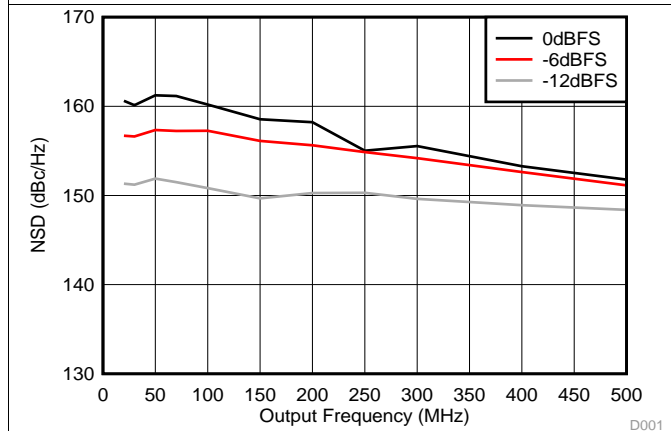


Figure 21. NSD vs Output Frequency Over Input Scale

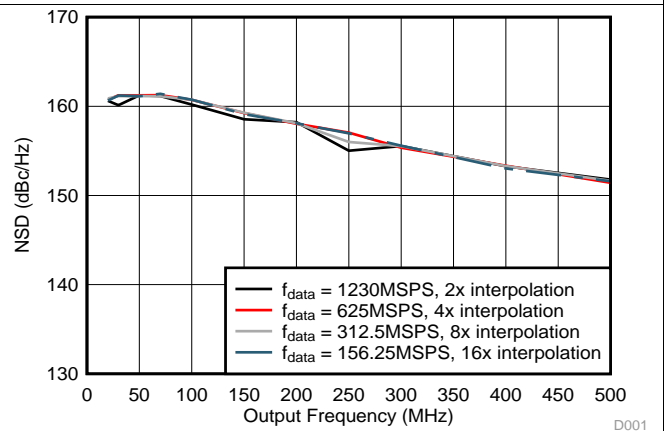


Figure 22. NSD vs Output Frequency Over Interpolation

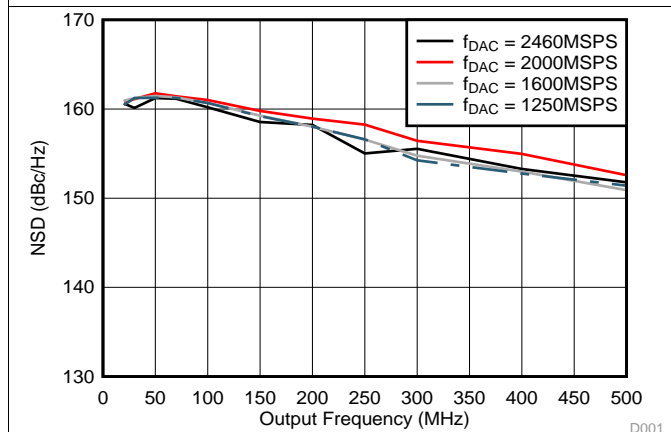


Figure 23. NSD vs Output Frequency Over  $f_{\text{DAC}}$

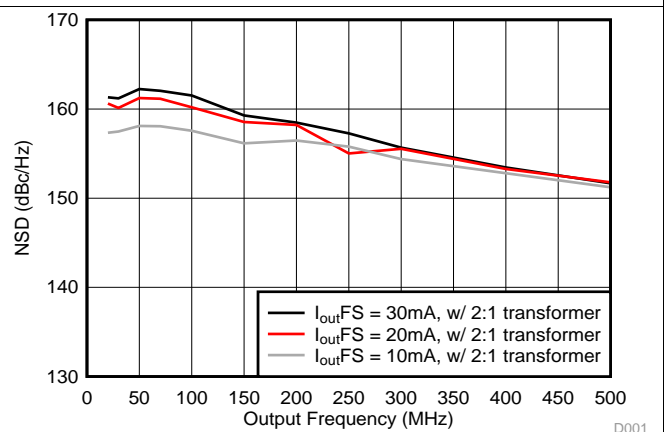
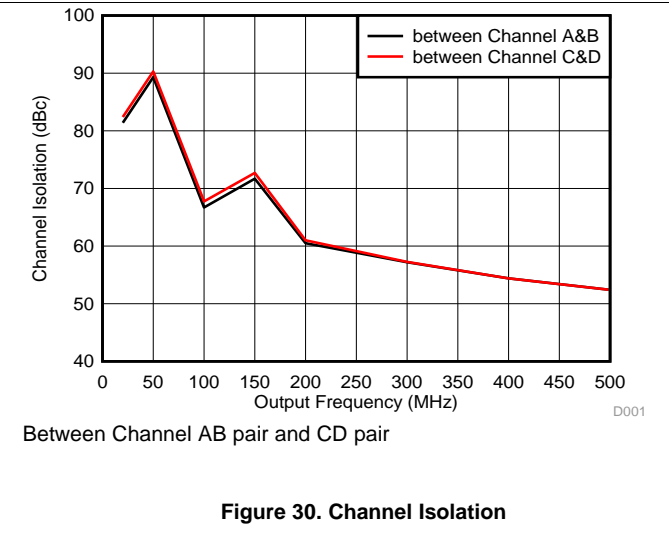
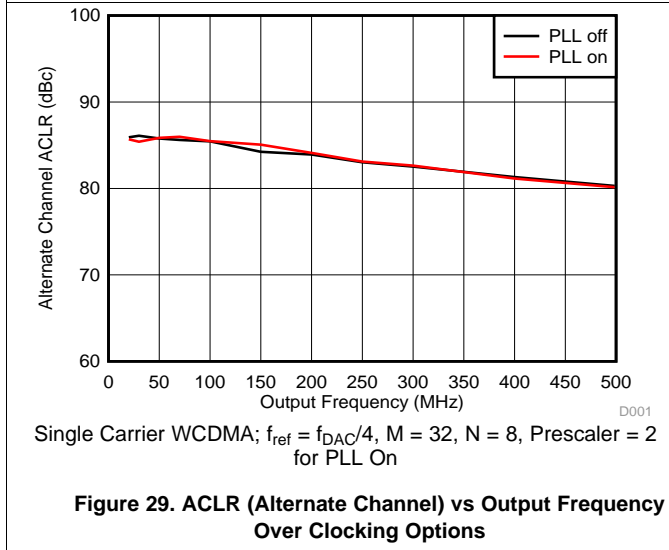
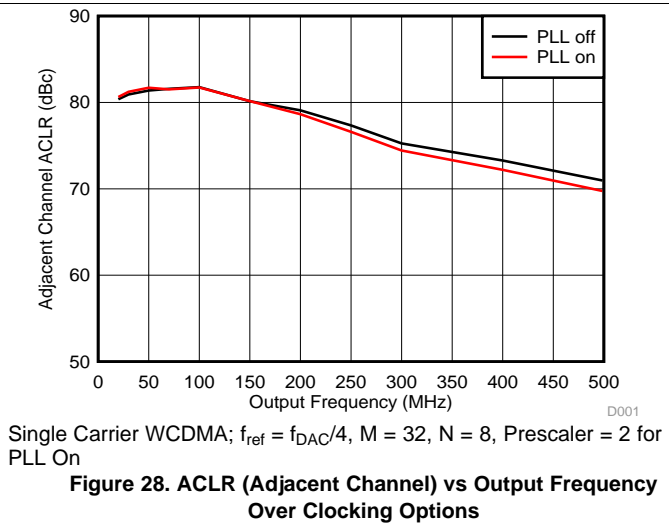
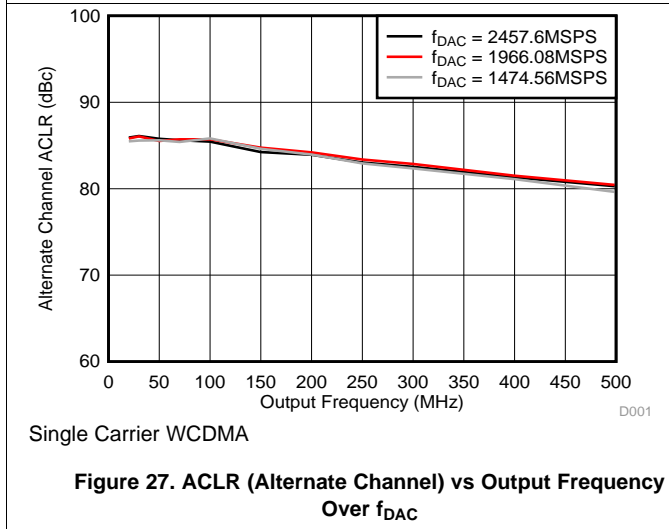
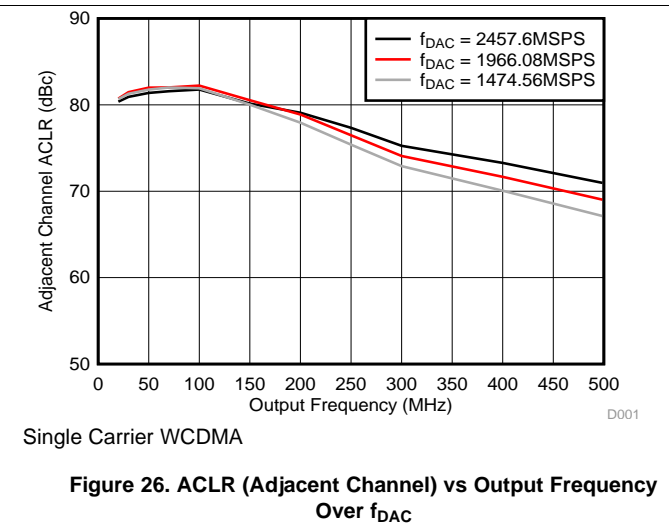
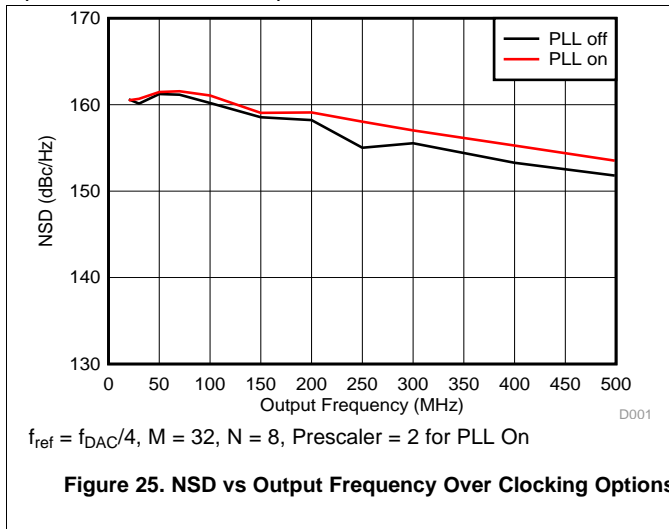


Figure 24. NSD vs Output Frequency Over Output Current  $I_{\text{outFS}}$

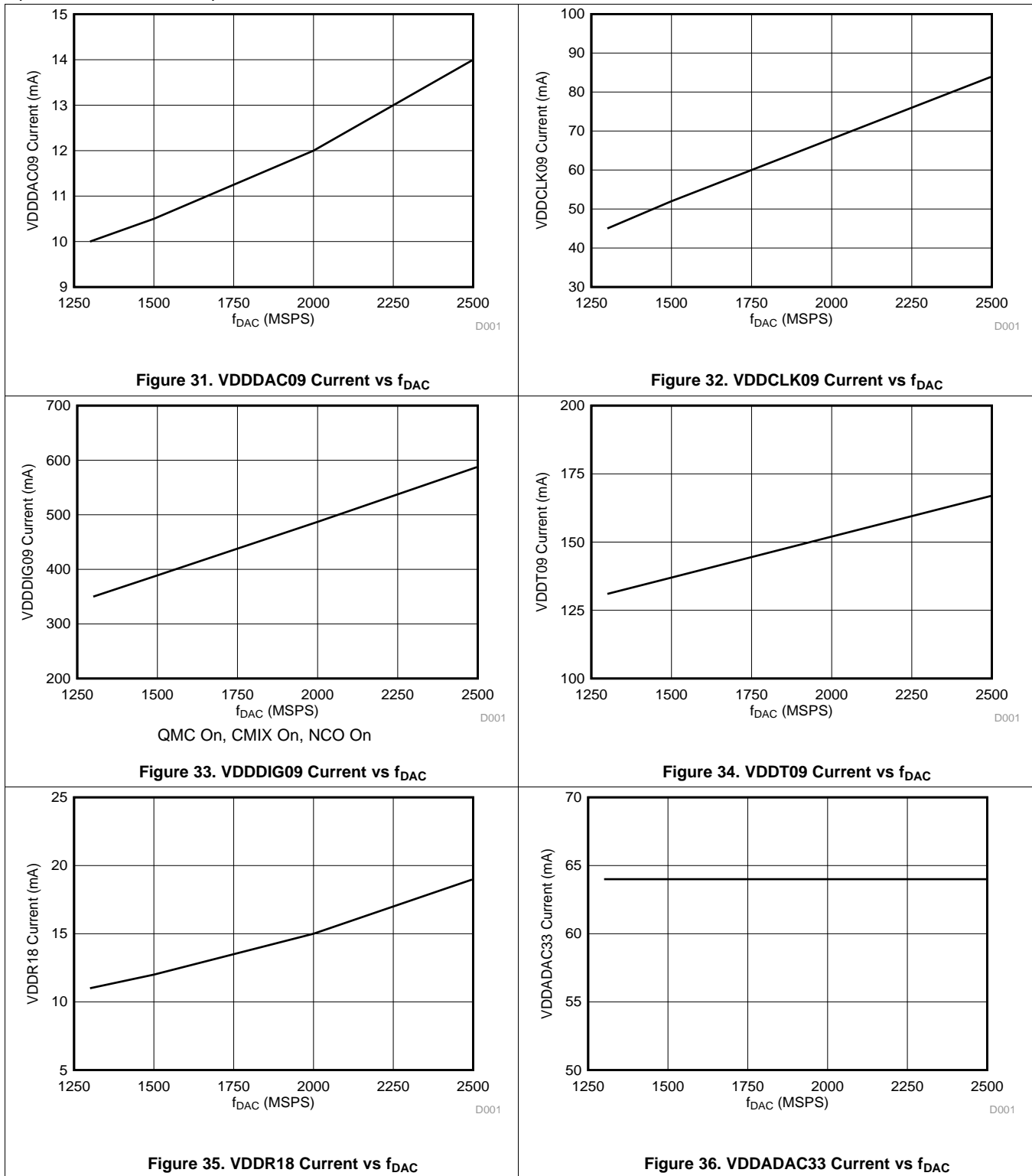
Typical Characteristics (continued)

Unless otherwise noted, all plots are at  $T_A = 25^\circ\text{C}$ , nominal supply voltages,  $f_{\text{DAC}} = 2460\text{MSPS}$ , 2x interpolation, 0dBFS digital input, 20mA full scale output current with 2:1 transformer, LMF = 421 and PLL is disabled.



Typical Characteristics (continued)

Unless otherwise noted, all plots are at  $T_A = 25^\circ\text{C}$ , nominal supply voltages,  $f_{\text{DAC}} = 2460\text{MSPS}$ , 2x interpolation, 0dBFS digital input, 20mA full scale output current with 2:1 transformer, LMF = 421 and PLL is disabled.



### Typical Characteristics (continued)

Unless otherwise noted, all plots are at  $T_A = 25^\circ\text{C}$ , nominal supply voltages,  $f_{\text{DAC}} = 2460\text{MSPS}$ , 2x interpolation, 0dBFS digital input, 20mA full scale output current with 2:1 transformer, LMF = 421 and PLL is disabled.

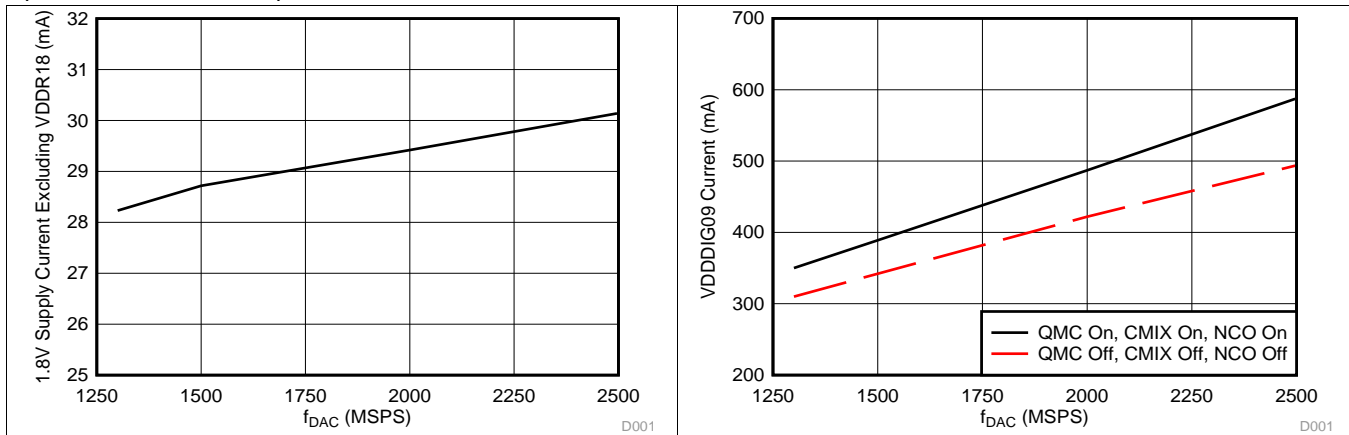


Figure 37. 1.8V Supply Current Excluding VDDR18 vs  $f_{\text{DAC}}$

Figure 38. VDDDIG09 Current vs  $f_{\text{DAC}}$  Over Digital Processing Functions

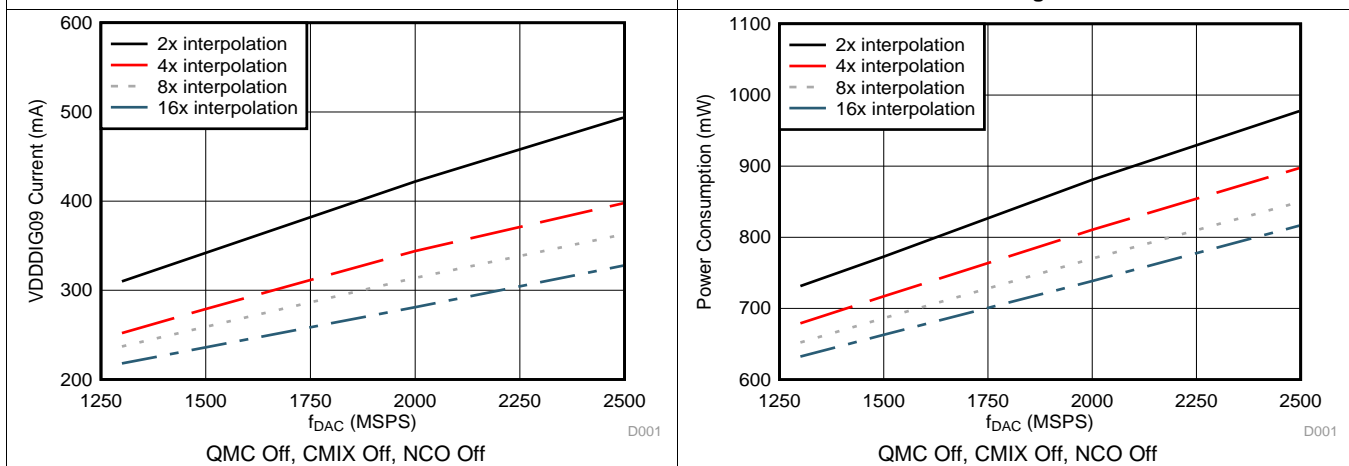


Figure 39. VDDDIG09 Current vs  $f_{\text{DAC}}$  Over Interpolation

Figure 40. Power Consumption vs  $f_{\text{DAC}}$  Over Interpolation

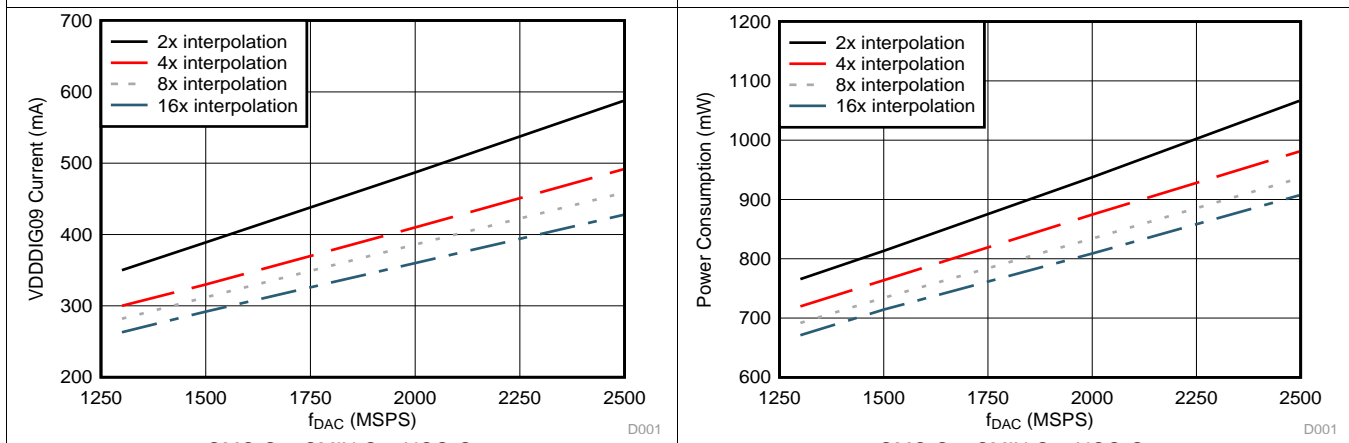


Figure 41. VDDDIG09 Current vs  $f_{\text{DAC}}$  Over Interpolation

Figure 42. Power Consumption vs  $f_{\text{DAC}}$  Over Interpolation

Typical Characteristics (continued)

Unless otherwise noted, all plots are at  $T_A = 25^\circ\text{C}$ , nominal supply voltages,  $f_{\text{DAC}} = 2460\text{MSPS}$ , 2x interpolation, 0dBFS digital input, 20mA full scale output current with 2:1 transformer, LMF = 421 and PLL is disabled.

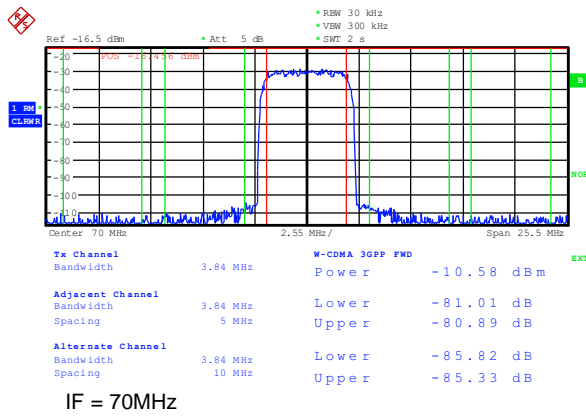


Figure 43. Single Carrier W-CDMA Test Mode 1

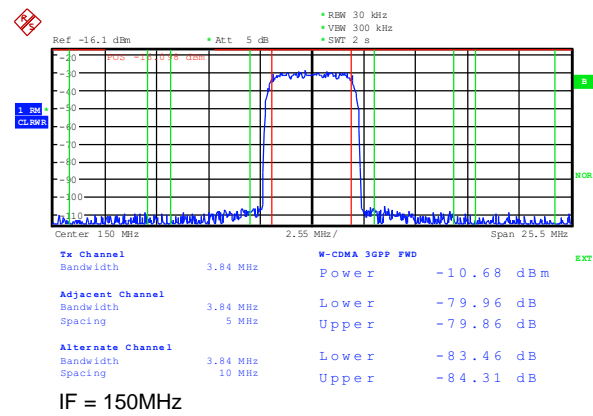


Figure 44. Single Carrier W-CDMA Test Mode 1

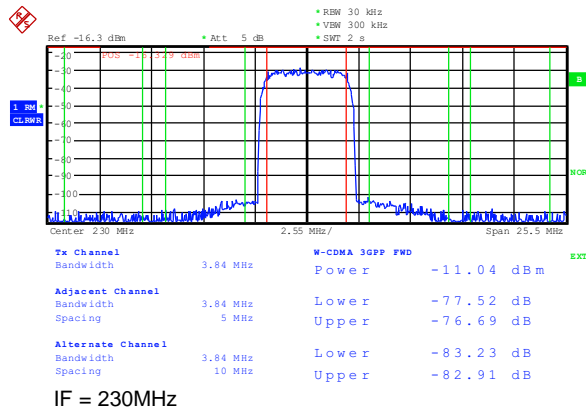


Figure 45. Single Carrier W-CDMA Test Mode 1

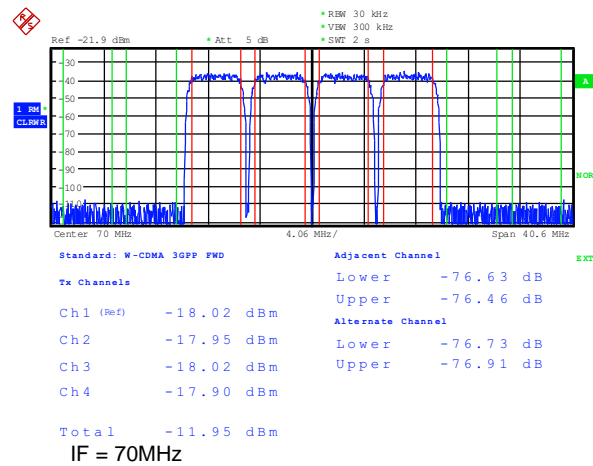


Figure 46. Four Carrier W-CDMA Test Mode 1

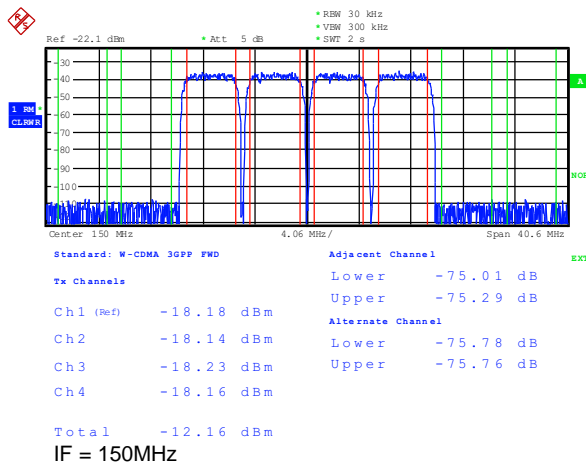


Figure 47. Four Carrier W-CDMA Test Mode 1

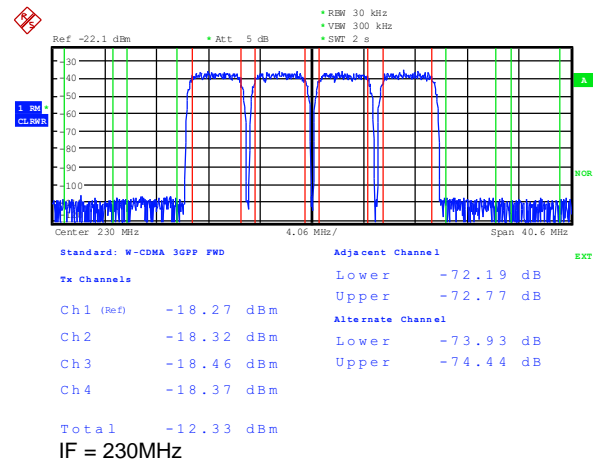
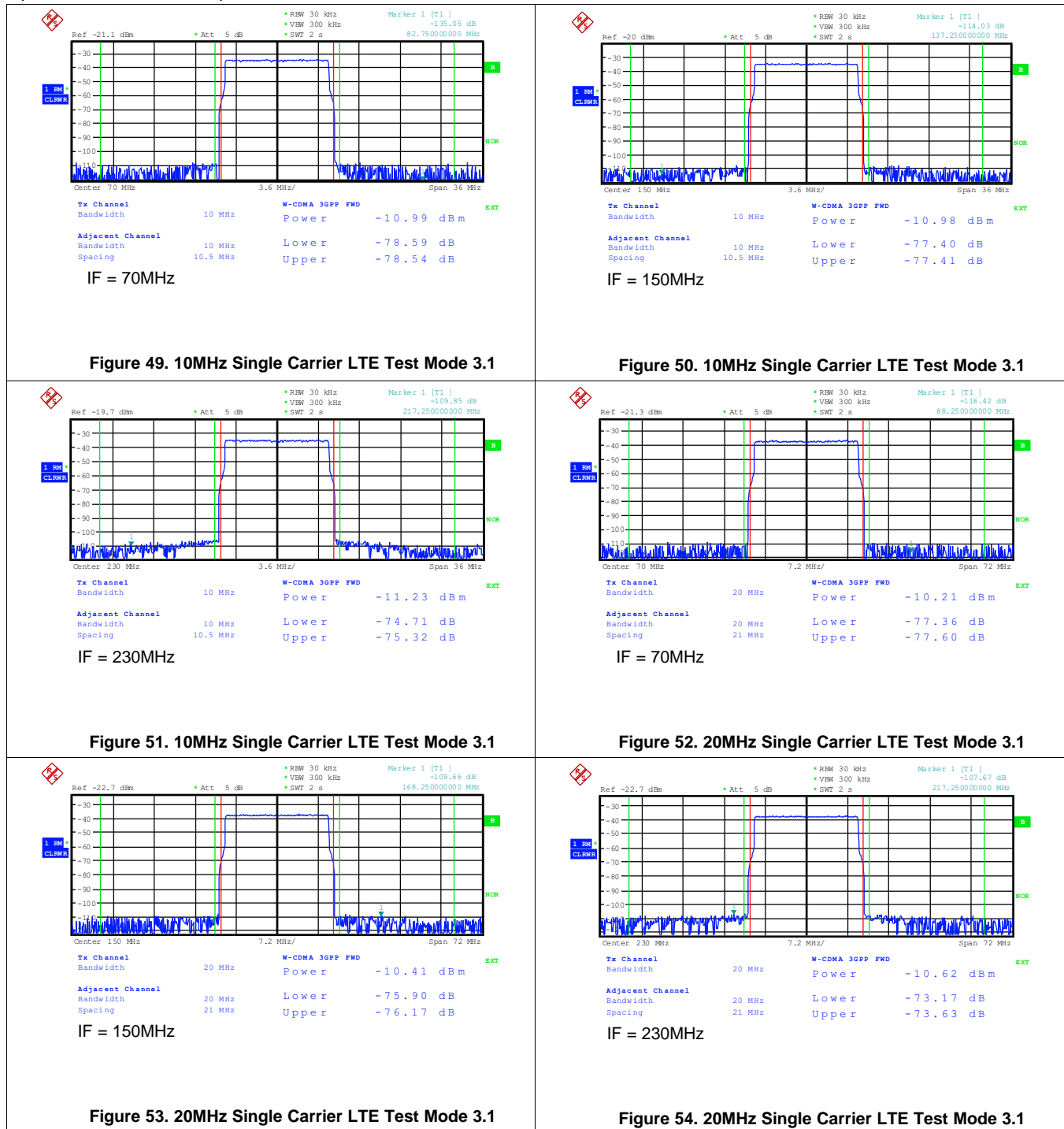


Figure 48. Four Carrier W-CDMA Test Mode 1

### Typical Characteristics (continued)

Unless otherwise noted, all plots are at  $T_A = 25^\circ\text{C}$ , nominal supply voltages,  $f_{\text{DAC}} = 2460\text{MSPS}$ , 2x interpolation, 0dBFS digital input, 20mA full scale output current with 2:1 transformer, LMF = 421 and PLL is disabled.



## 7 Detailed Description

### 7.1 Overview

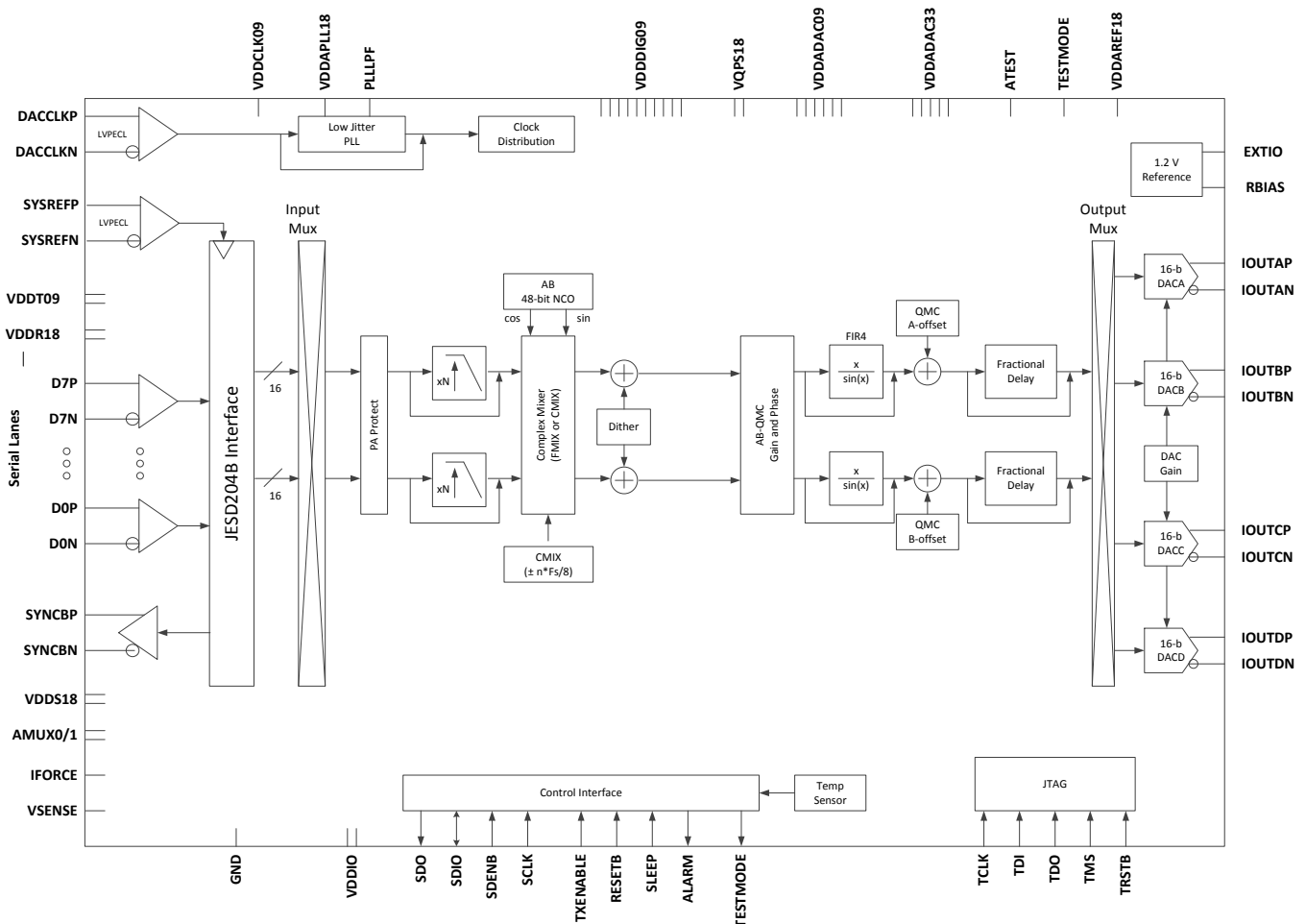
The pin-compatible DAC37J82/DAC38J82 family is a very low power, 16-bit, 1.6/2.5 GSPS digital to analog converter (DAC) with JESD204B interface up to 12.5 Gbps. The maximum input data rate is 1.23 GSPS. The DAC37J82/DAC38J82 family is also pin-compatible with the 16-bit, dual-channel, 1.6/2.5GSPS DAC37J82/DAC38J82.

Digital data is input to the device through 1, 2, 4 or 8 configurable serial JESD204B lanes running up to 12.5 Gbps with on-chip termination and programmable equalization. The interface allows JESD204B Subclass 1 SYSREF based deterministic latency and full synchronization of multiple devices.

The device includes features that simplify the design of complex transmit architectures. Fully bypassable 2x to 16x digital interpolation filters with over 90 dB of stop-band attenuation simplify the data interface and reconstruction filters. An on-chip 48-bit Numerically Controlled Oscillator (NCO) and independent complex mixers allow flexible and accurate carrier placement. A high-performance low jitter PLL simplifies clocking of the device without significant impact on the dynamic range. The digital Quadrature Modulator Correction (QMC) and Group Delay Correction (GDC) enable complete wideband IQ compensation for gain, offset, phase, and group delay between channels in direct up-conversion applications. A programmable Power Amplifier (PA) protection mechanism is available to provide PA protection in cases when the abnormal power behavior of the input data is detected.

DAC37J82/DAC38J82 family provides four analog outputs, and the data from the internal two digital paths can be routed to any two out of these four DAC outputs via the output multiplexer.

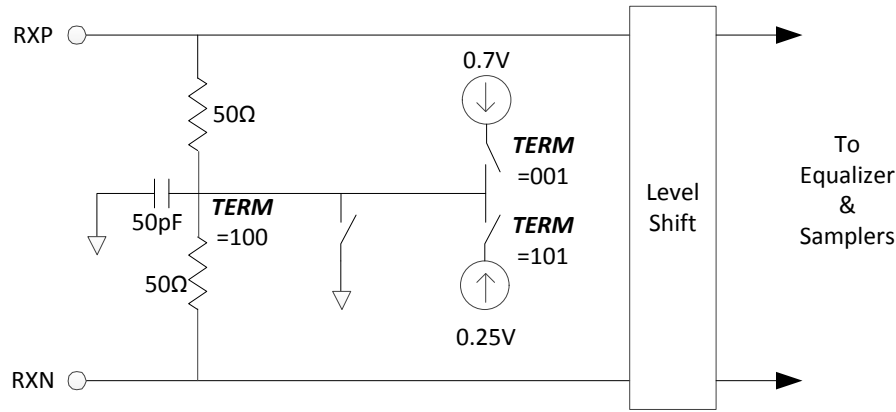
### 7.2 Functional Block Diagram



## 7.3 Feature Description

### 7.3.1 Serdes Input

The RX[7:0]P/N differential inputs are each internally terminated to a common point via 50Ω, as shown in Figure 55.



**Figure 55. Serial Lane Input Termination**

Common mode termination is via a 50pF capacitor to GND. The common mode voltage and termination of the differential signal can be controlled in a number of ways to suit a variety of applications via `rw_cfg_rx0` [10:8] (**TERM**), as described in Table 1.

**(Note: AC coupling is recommended for JESD204B compliance.)**

**Table 1. Receiver Termination Selection**

TERM	EFFECT
000	Reserved
001	Common point set to 0.7V. This configuration is for AC coupled systems. The transmitter has no effect on the receiver common mode, which is set to optimize the input sensitivity of the receiver.
01x	Reserved
100	Common point set to GND. This configuration is for applications that require a 0V common mode.
101	Common point set to 0.25V. This configuration is for applications that require a low common mode.
110	Reserved
111	Common point floating. This configuration is for DC coupled systems in which the common mode voltage is set by the attached transmit link partner to 0 and 0.6V. Note: this mode is not compatible with JESD204B.

Data input is sampled by the differential sensing amplifier using clocks derived from the clock recovery algorithm. The polarity of RXP and RXN can be inverted by setting the **INVPAIR** [7:0] bit of the corresponding lane to “1”. This can potentially simplify PCB layout and improve signal integrity by avoiding the need to swap over the differential signal traces.

Due to processing effects, the devices in the RXP and RXN differential sense amplifiers will not be perfectly matched and there will be some offset in switching threshold. DAC38J82/DAC37J82 family contains circuitry to detect and correct for this offset. This feature can be enabled by setting the `rw_cfg_rx0` [23] (**ENOC**) bit to “1”. It is anticipated the most users will enable this feature. During the compensation process, `rw_cfg_rx0` [25:24] (**LOOPBACK**) bit must be set to “00”.

### 7.3.2 Serdes Rate

The DAC37J82/DAC38J82 has 8 configurable JESD204B serial lanes. The highest speed of each SerDes lane is 12.5Gbps. Because the primary operating frequency of the SerDes is determined by its reference clock and PLL multiplication factor, there is a limit on the lowest SerDes rate supported, refer to Table 2 for details. To support lower speed application, each receiver should be configured to operate at half, quarter or eighth of the full rate via `rw_cfg_rx0` [6:5] (**RATE**).



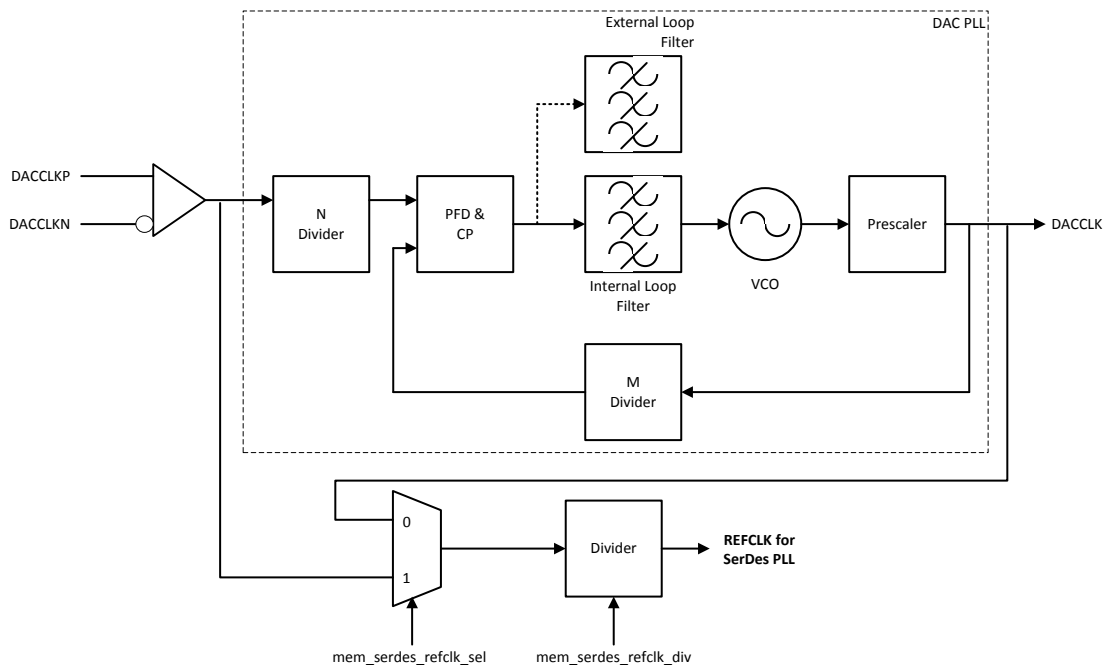
**Table 2. Lane Rate Selection**

RATE	EFFECT
00	Full rate. Four data samples taken per SerDes PLL output clock cycle.
01	Half rate. Two data samples taken per SerDes PLL output clock cycle..
10	Quarter rate. One data samples taken per SerDes PLL output clock cycle.
11	Eighth rate. One data samples taken every two SerDes PLL output clock cycles.

**7.3.3 Serdes PLL**

The DAC37J82/DAC38J82 has two integrated PLLs, one PLL is to provide the clocking of DAC, which will be discussed in a DAC PLL section; the other PLL is to provide the clocking for the high speed SerDes. The reference frequency of the SerDes PLL can be in the range of 100-800MHz nominal, and 300-800MHz optimal.

The reference frequency is derived from DACCLK divided down based on the *serdes\_refclk\_div* programming, as shown in Figure 56.



**Figure 56. Reference Clock of SerDes PLL**

During normal operation, the clock generated by PLL will be 4-25 times the reference frequency, according to the multiply factor selected via *rw\_cfgpll* [8:1] (MPY). In order to select the appropriate multiply factor and refclkp/n frequency, it is first necessary to determine the required PLL output clock frequency. The relationship between the PLL output clock frequency and the lane rate is shown in Table 3. Having computed the PLL output frequency, the reference frequency can be obtained by dividing this by the multiply factor specified via MPY.

**NOTE**

High multiplication factor settings will be especially sensitive to reference clock jitter and should not be employed without prior consultation with TI.

**Table 3. Relationship Between Lane Rate and SerDes PLL Output Frequency**

RATE	LINE RATE	PLL OUTPUT FREQUENCY
Full	x Gbps	0.25x GHz
Half	x Gbps	0.5x GHz

**Table 3. Relationship Between Lane Rate and SerDes PLL Output Frequency (continued)**

RATE	LINE RATE	PLL OUTPUT FREQUENCY
Quarter	x Gbps	1x GHz
Eighth	x Gbps	2x GHz

**Table 4. SerDes PLL Modes Selection**

MPY	EFFECT
00010000	4x
00010100	5x
00011000	6x
00100000	8x
00100001	8.25x
00101000	10x
00110000	12x
00110010	12.5x
00111100	15x
01000000	16x
01000010	16.5x
01010000	20x
01011000	22x
01100100	25x
Other codes	reserved

The wide range of multiply factors combined with the different rate modes means it will often be possible to achieve a given line rate from multiple different reference frequencies. The configuration which utilizes the highest reference frequency achievable is always preferable.

The SerDes PLL VCO must be in the nominal range of 1.5625 - 3.125 GHz. It is necessary to adjust the loop filter depending on the operating frequency of the VCO. To indicate the selection the user must set the *rw\_cfgpll* [9] (**VRANGE**) bit. If the PLL output frequency is below 2.17GHz, **VRANGE** should be set high.

Performance of the integrated PLL can be optimized according to the jitter characteristics of the reference clock by setting the appropriate loop bandwidth via *rw\_cfgpll* [12:11] (**LB**) bits. The loop bandwidth is obtained by dividing the reference frequency by BWSCALE, where the BWSCALE is a function of both LB and PLL output frequency as shown in [Table 5](#).

**Table 5. SerDes PLL Loop Bandwidth Selection**

LB	EFFECT	BWSCALE vs PLL OUTPUT FREQUENCY		
		3.125 GHz	2.17 GHz	1.5625 GHz
00	Medium loop bandwidth	13	14	16
01	Ultra high loop bandwidth	7	8	8
10	Low loop bandwidth	21	23	30
11	High loop bandwidth	10	11	14

An approximate loop bandwidth of 8–30MHz is suitable and recommended for most systems where the reference clock is via low jitter clock input buffer. For systems where the reference clock is via a low jitter input cell, but of low quality, an approximate loop bandwidth of less than 8MHz may offer better performance. For systems where the reference clock is cleaned via an ultra low jitter LC-based cleaner PLL, a high loop bandwidth up to 60MHz is more appropriate. Note that the use of ultra high loop bandwidth setting is not recommended for PLL multiply factor of less than 8.

A free running clock output is available when *rw\_cfgpll* [15:14] (**ENDIVCLK**) is set high. It runs at a fixed divided-by-5 of the PLL output frequency and has a duty cycle of 50%. A divided-by-16 of this free running clock can be configured to come out the alarm pin during digital test, see *dtest* [11:8] for the specific configuration needed.

### 7.3.4 Serdes Equalizer

All channels of the DAC37J82/DAC38J82 incorporate an adaptive equalizer, which can compensate for channel insertion loss by attenuating the low frequency components with respect to the high frequency components of the signal, thereby reducing inter-symbol interference. Figure 57 shows the response of the equalizer, which can be expressed in terms of the amount of low frequency gain and the frequency up to which this gain is applied (i.e., the frequency of the 'zero'). Above the zero frequency, the gain increases at 6dB/octave until it reaches the high frequency gain.

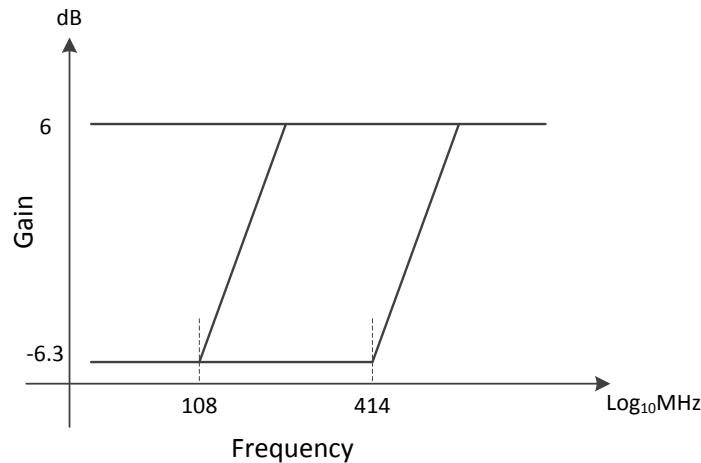


Figure 57. Equalizer Frequency Response

The equalizer can be configured via *rw\_cfgrx0*[21:19] (EQ) and *rx\_cfgrx0*[22] (EQHLD). Table 6 and Table 7 summarize the options. When enabled, the receiver equalization logic analyzes data patterns and transition times to determine whether the low frequency gain should be increased or decreased. The decision logic is implemented as a voting algorithm with a relatively long analysis interval. The slow time constant that results reduces the probability of incorrect decisions but allows the equalizer to compensate for the relatively stable response of the channel. The lock time for the adaptive equalizer is data dependent, and so it is not possible to specify a generally applicable absolute limit. However, assuming random data, the maximum lock time will be  $6 \times 10^6$  divided by the CDR activity level. For CDR (*rw\_cfgrx0*[18:16]) = 110, this is  $1.5 \times 10^6$  UI.

When EQ[2] = 0, finer control of gain boost is available using the EQBOOSTi IEEE1500 tuning chain field, as shown in Table 8.

Table 6. Receiver Equalization Configuration

EQ		EFFECT
[1:0]	0	<i>No equalization.</i> The equalizer provides a flat response at the maximum gain. This setting may be appropriate if jitter at the receiver occurs predominantly as a result of crosstalk rather than frequency dependent loss.
	1	<i>Fully adaptive equalization.</i> The zero position is determined by the selected operating rate, and the low frequency gain of the equalizer is determined algorithmically by analyzing the data patterns and transition positions in the received data. This setting should be used for most applications.
	10	<i>Precursor equalization analysis.</i> The data patterns and transition positions in the received data are analyzed to determine whether the transmit link partner is applying more or less precursor equalization than necessary.
	11	<i>Postcursor equalization analysis.</i> The data patterns and transition positions in the received data are analyzed to determine whether the transmit link partner is applying more or less postcursor equalization than necessary.
[2]	0	Default
	1	<i>Boost.</i> Equalizer gain boosted by 6dB, with a 20% reduction in bandwidth, and an increase of 5mW power consumption. May improve performance over long links.

**Table 7. Receiver Equalizer Hold**

EQHOLD	EFFECT
0	<i>Equalizer adaption enabled.</i> The equalizer adaption and analysis algorithm is enabled. This should be the default state.
1	<i>Equalizer adaption held.</i> The equalizer is held in it's current state. Additionally, the adaption and analysis algorithm is reset. See section 7.2.5.1 for further details..

**Table 8. Receiver Equalizer Gain Boost**

EQBoost VALUE	GAIN BOOST (dB)	BANDWIDTH CHANGE (%)	POWER INCREASE (mW)
0	0	0	0
1	2	-30	0
10	4	10	5
11	6	-20	5

When EQ is set to 010 or 011, the equalizer is reconfigured to provide analytical data about the amount of pre and post cursor equalization respectively present in the received signal. This can in turn be used to adjust the equalization settings of the transmitting link partner, where a suitable mechanism for communicating this data back to the transmitter exists. Status information is provided via **dtest[11:8]** (EQOVER, EQUNDER), by using the following method:

1. Enable the equalizer by setting EQHLD low and EQ to 001. Allow sufficient time for the equalizer to adapt;
2. Set EQHLD to 1 to lock the equalizer and reset the adaption algorithm. This also causes both EQOVER and EQUNDER to become low;
3. Wait at least 48UI, and proportionately longer if the CDR activity is less than 100%, to ensure the 1 on EQHLD is sampled and acted upon;
4. Set EQ to 010 or 011, and EQHLD to 0. The equalization characteristics of the received signal are analysed (the equalizer response will continue to be locked);
5. Wait at least  $150 \times 10^3$ UI to allow time for the analysis to occur, proportionately longer if the CDR activity is less than 100%;
6. Examine EQOVER and EQUNDER for results of analysis.
  - If EQOVER is high, it indicates the signal is over equalized;
  - If EQUNDER is high, it indicates the signal is under equalized;
7. Set EQHLD to 1;
8. Repeat items 3–7 if required;
9. Set EQ to 001, and EQHLD to 0 to exit analysis mode and return to normal adaptive equalization.

Note that when changing EQ from one non-zero value to another, EQHLD must already be 1. If this is not the case, there is a chance the equalizer could be reset by a transitory input state (i.e., if EQ is momentarily 000). EQHLD can be set to 0 at the same time as EQ is changed.

As the equalizer adaption algorithm is designed to equalize the post cursor, EQOVER or EQUNDER will only be set during post cursor analysis if the amount of post cursor equalization required is more or less than the adaptive equalizer can provide.

### 7.3.5 JESD204B Descrambler

The descrambler is a 16-bit parallel self-synchronous descrambler based on the polynomial  $1 + x^{14} + x^{15}$ . From the JESD204B specification, the scrambling/descrambling process only occurs on the user data, not on the code group synchronization or the ILA sequence. The descrambler output can be selected to sent out during JESD test, see **jesd\_testbus\_sel** for the specific configuration needed.

### 7.3.6 JESD204B Frame Assembly

The JESD204B defines the following parameters:

- L is the number of lanes per link
- M is the number of converters per device
- F is the number of octets per frame clock period

- S is the number of samples per frame
- HD is the High-Density bit which controls whether a sample may be divided over more lanes.

Table 9 list the available JESD204B formats for the DAC37J82/DAC38J82. Table 10 and Table 11 list the speed limits of DAC38J82/DAC37J82. The ranges are limited by the Serdes PLL VCO frequency range, the Serdes PLL reference clock range, the maximum Serdes line rate, and the maximum DAC sample frequency.

**Table 9. JESD204B Frame Assembly Byte Representation**

	LMF = 821			LMF = 421				LMF = 222				LMF = 124							
Lane 0	I0[15:8]	I2[15:8]	I4[15:8]	I0[15:8]	I1[15:8]	I2[15:8]	I3[15:8]	I0[15:8]	I0[7:0]	I1[15:8]	I1[7:0]	I0[15:8]	I0[7:0]	Q0[15:8]	Q0[7:0]	I1[15:8]	I1[7:0]	Q1[15:8]	Q1[7:0]
Lane 1	I0[7:0]	I2[7:0]	I4[7:0]	I0[7:0]	I1[7:0]	I2[7:0]	I3[7:0]	Q0[15:8]	Q0[15:8]	Q0[7:0]	Q1[15:8]								
Lane 2	I1[15:8]	I3[15:8]	I5[15:8]	Q0[15:8]	Q1[15:8]	Q2[15:8]	Q3[15:8]												
Lane 3	I1[7:0]	I3[7:0]	I5[7:0]	Q0[7:0]	Q1[7:0]	Q2[7:0]	Q3[7:0]												
Lane 4	Q0[15:8]	Q2[15:8]	Q4[15:8]																
Lane 5	Q0[7:0]	Q2[7:0]	Q4[7:0]																
Lane 6	Q1[15:8]	Q3[15:8]	Q5[15:8]																
Lane 7	Q1[7:0]	Q3[7:0]	Q5[7:0]																

**Table 10. DAC38J82 Speed Limits**

L	M	F	S	HD	INTERPOLATION	Min $f_{\text{SERDES}}$ (Gbps)	Max $f_{\text{SERDES}}$ (Gbps)	Min $f_{\text{DATA}}$ (MSPS)	Max $f_{\text{DATA}}$ (MSPS)	Min $f_{\text{DAC}}$ (MSPS)	Max $f_{\text{DAC}}$ (MSPS)	Max BW (MHz)
8	2	1	2	1	1	0.78125	6.15	156.25	1230	156.25	1230	1230
					2	0.78125	6.15	156.25	1230	312.5	2460	984
					4	0.78125	3.125	156.25	625	625	2500	500
					8	0.78125	1.5625	156.25	312.5	1250	2500	250
					16	N/A	N/A	N/A	N/A	N/A	N/A	N/A
4	2	1	1	1	1	1	12.3	100	1230	100	1230	1230
					2	0.78125	12.3	78.125	1230	156.25	2460	984
					4	0.78125	6.25	78.125	625	312.5	2500	500
					8	0.78125	3.125	78.125	312.5	625	2500	250
					16	0.78125	1.5625	78.125	156.25	1250	2500	125
2	2	2	1	0	1	2	12.5	100	625	100	625	625
					2	1	12.5	50	625	100	1250	500
					4	0.78125	12.5	39.0625	625	156.25	2500	500
					8	0.78125	6.25	39.0625	312.5	312.5	2500	250
					16	0.78125	3.125	39.0625	156.25	625	2500	125
1	2	4	1	0	1	N/A	N/A	N/A	N/A	N/A	N/A	N/A
					2	2	12.5	50	312.5	100	625	250
					4	1.5625	12.5	39.0625	312.5	156.25	1250	250
					8	1.5625	12.5	39.0625	312.5	312.5	2500	250
					16	1.5625	6.25	39.0625	156.25	625	2500	125

L = # of lanes

M = # of DACs

F = # of Octets per lane per frame cycle

S = # of Samples per DAC per frame cycle

HD = High density mode

 $f_{\text{SERDES}}$  = Serdes line rate

 $f_{\text{DATA}}$  = Input data rate per DAC

 $f_{\text{DAC}}$  = Output sample rate

 BW = Complex bandwidth (=  $f_{\text{DATA}} \times 0.8$  with interpolation, =  $f_{\text{DATA}}$  without interpolation)

**Table 11. DAC37J82 Speed Limits**

L	M	F	S	HD	INTERPOLATION	Min $f_{\text{SERDES}}$ (Gbps)	Max $f_{\text{SERDES}}$ (Gbps)	Min $f_{\text{DATA}}$ (MSPS)	Max $f_{\text{DATA}}$ (MSPS)	Min $f_{\text{DAC}}$ (MSPS)	Max $f_{\text{DAC}}$ (MSPS)	Max BW (MHz)
8	2	1	2	1	1	0.78125	6.15	156.25	1230	156.25	1230	1230
					2	0.78125	4	156.25	800	312.5	1600	640
					4	0.78125	2	156.25	400	625	1600	320
					8	0.78125	1	156.25	200	1250	1600	160
					16	N/A	N/A	N/A	N/A	N/A	N/A	N/A
4	2	1	1	1	1	1	12.3	100	1230	100	1230	1230
					2	0.78125	8	78.125	800	156.25	1600	640
					4	0.78125	4	78.125	400	312.5	1600	320
					8	0.78125	2	78.125	200	625	1600	160
					16	0.78125	1	78.125	100	1250	1600	80
2	2	2	1	0	1	2	12.5	100	625	100	625	625
					2	1	12.5	50	625	100	1250	500
					4	0.78125	8	39.0625	400	156.25	1600	320
					8	0.78125	4	39.0625	200	312.5	1600	160
					16	0.78125	2	39.0625	100	625	1600	80
1	2	4	1	0	1	N/A	N/A	N/A	N/A	N/A	N/A	N/A
					2	2	12.5	50	312.5	100	625	250
					4	1.5625	12.5	39.0625	312.5	156.25	1250	250
					8	1.5625	8	39.0625	200	312.5	1600	160
					16	1.5625	4	39.0625	100	625	1600	80

L = # of lanes

M = # of DACs

F = # of Octets per lane per frame cycle

S = # of Samples per DAC per frame cycle

HD = High density mode

 $f_{\text{SERDES}}$  = Serdes line rate

 $f_{\text{DATA}}$  = Input data rate per DAC

 $f_{\text{DAC}}$  = Output sample rate

 BW = Complex bandwidth (=  $f_{\text{DATA}} \times 0.8$  with interpolation, =  $f_{\text{DATA}}$  without interpolation)

### 7.3.7 Serial Peripheral Interface (SPI)

The serial port of the DAC37J82/DAC38J82 is a flexible serial interface which communicates with industry standard microprocessors and microcontrollers. The interface provides read/write access to all registers used to define the operating modes of the DAC37J82/DAC38J82. It is compatible with most synchronous transfer formats and can be configured as a 3 or 4 pin interface by *sif4\_ena* in register *config2*. In both configurations, SCLK is the serial interface input clock and SDENB is serial interface enable. For 3 pin configuration, SDIO is a bidirectional pin for both data in and data out. For 4 pin configuration, SDIO is bidirectional and SDO is data out only. Data is input into the device with the rising edge of SCLK. Data is output from the device on the falling edge of SCLK.

Each read/write operation is framed by signal SDENB (Serial Data Enable Bar) asserted low. The first frame byte is the instruction cycle which identifies the following data transfer cycle as read or write as well as the 7-bit address to be accessed. [Table 12](#) indicates the function of each bit in the instruction cycle and is followed by a detailed description of each bit. The data transfer cycle consists of two bytes.

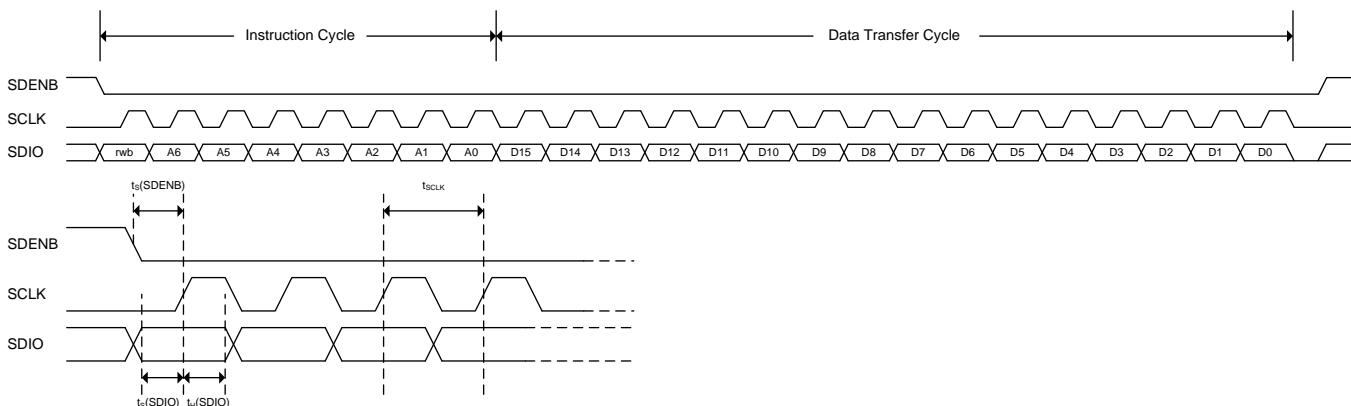
**Table 12. Instruction Byte of the Serial Interface**

Bit	7 (MSB)	6	5	4	3	2	1	0 (LSB)
Description	R/W	A6	A5	A4	A3	A2	A1	A0

**R/W** Identifies the following data transfer cycle as a read or write operation. A high indicates a read operation from the DAC37J82/DAC38J82 and a low indicates a write operation to the DAC37J82/DAC38J82.

**[A6 : A0]** Identifies the address of the register to be accessed during the read or write operation.

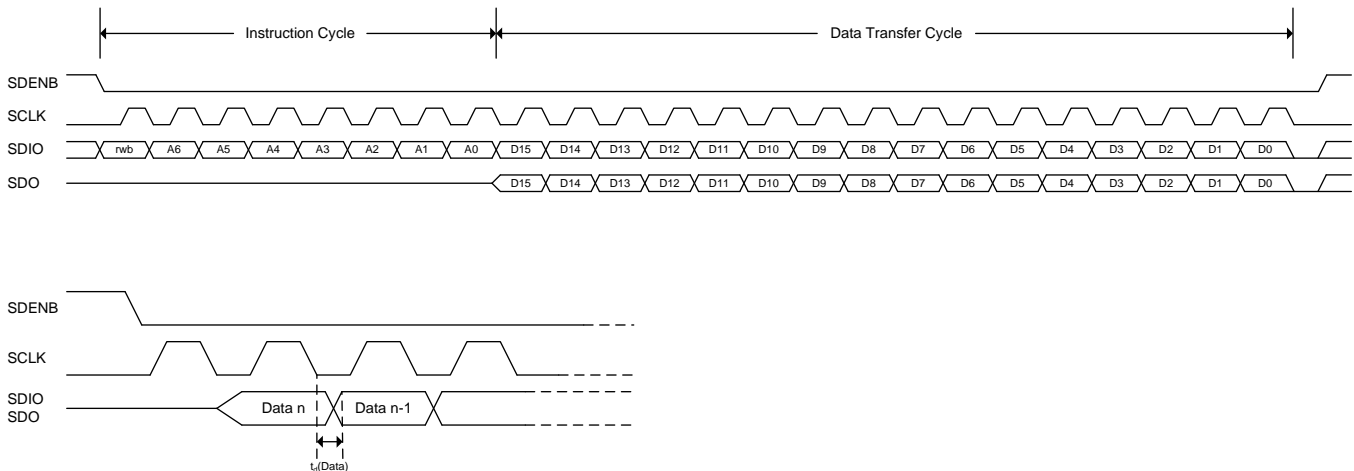
[Figure 58](#) shows the serial interface timing diagram for a DAC37J82/DAC38J82 write operation. SCLK is the serial interface clock input to the DAC37J82/DAC38J82. Serial data enable SDENB is an active low input to the DAC37J82/DAC38J82. SDIO is serial data in. Input data to the DAC37J82/DAC38J82 is clocked on the rising edges of SCLK.



**Figure 58. Serial Interface Write Timing Diagram**

[Figure 59](#) shows the serial interface timing diagram for a DAC37J82/DAC38J82 read operation. SCLK is the serial interface clock input to the DAC37J82/DAC38J82. Serial data enable SDENB is an active low input to the DAC37J82/DAC38J82. SDIO is serial data in during the instruction cycle. In 3 pin configuration, SDIO is data out from the DAC37J82/DAC38J82 during the data transfer cycle, while SDO is in a high-impedance state. In 4 pin configuration, both SDIO and SDO are data out from the DAC37J82/DAC38J82 during the data transfer cycle. At the end of the data transfer, SDIO and SDO will output low on the final falling edge of SCLK until the rising edge of SDENB when they will 3-state.





**Figure 59. Serial Interface Read Timing Diagram**

In the SIF interface there are four types of registers:

- **NORMAL:** The NORMAL register type allows data to be written and read from. All 16-bits of the data are registered at the same time. There is no synchronizing with an internal clock thus all register writes are asynchronous with respect to internal clocks. There are three subtypes of NORMAL:
  - **AUTOSYNC:** A NORMAL register that causes a sync to be generated after the write is finished. These are used when it is desirable to synchronize the block after writing the register or in the case of a single field that spans across multiple registers. For instance, the NCO requires three 16-bit register writes to set the frequency. Upon writing the last of these registers an autosync is generated to deliver the entire field to the NCO block at once, rather than in pieces after each individual register write. For a field that spans multiple registers, all non-AUTOSYNC registers for the field must be written first before the actual AUTOSYNC register.
  - **No RESET Value:** These are NORMAL registers, but the reset value **cannot** be guaranteed. This could be because the register has some read\_only bits or some internal logic partially controls the bit values.
- **READ\_ONLY:** Registers that can be read from but not written to.
- **WRITE\_TO\_CLEAR:** These registers are just like NORMAL registers with one exception. They can be written and read, however, when the internal logic asynchronously sets a bit high in one of these registers, that bit stays high until it is written to '0'. This way interrupts will be captured and stay constant until cleared by the user. In the DAC37J82/DAC38J82, register *config100-108* are WRTE\_TO\_CLEAR registers.

### 7.3.8 Multi-Device Synchronization

In many applications, such as multi antenna systems where the various transmit channels information is correlated, it is required that the latency across the link is deterministic and multiple DAC devices are completely synchronized such that their outputs are phase aligned. The DAC37J82/DAC38J82 achieves the deterministic latency using SYSREF (JESD204B Subclass 1).

SYSREF is generated from the same clock domain as DACCLK, and is sampled at the rising edges of the device clock. It can be periodic, single-shot or “gapped” periodic. After having resynchronized its local multiframe clock (LMFC) to SYSREF, the DAC will request a link re-initialization via SYNC interface. Processing of the signal on the SYSREF input can be enabled and disabled via the SPI interface.

### 7.3.9 Input Multiplexer

The DAC37J82/DAC38J82 includes a multiplexer after the JESD204B interface that allows any input stream A-B to be routed to any signal channel A-B. See *pathx\_in\_sel* for details on how to configure the cross-bar switches.

### 7.3.10 FIR Filters

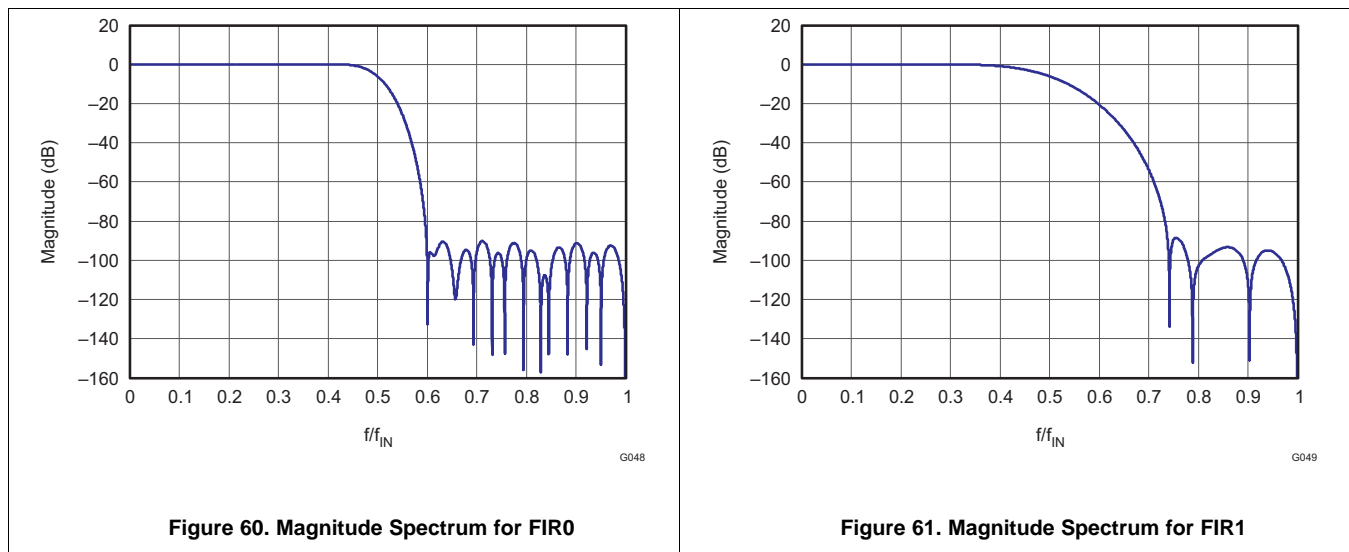
Figure 60 through Figure 63 show the magnitude spectrum response for the FIR0, FIR1, FIR2 and FIR3 interpolating filters where  $f_{IN}$  is the input data rate to the FIR filter. Figure 64 to Figure 67 show the composite filter response for 2x, 4x, 8x and 16x interpolation. The transition band for all interpolation settings is from 0.4 to  $0.6 \times f_{DATA}$  (the input data rate to the device) with  $< 0.001\text{dB}$  of pass-band ripple and  $> 90\text{ dB}$  stop-band attenuation.

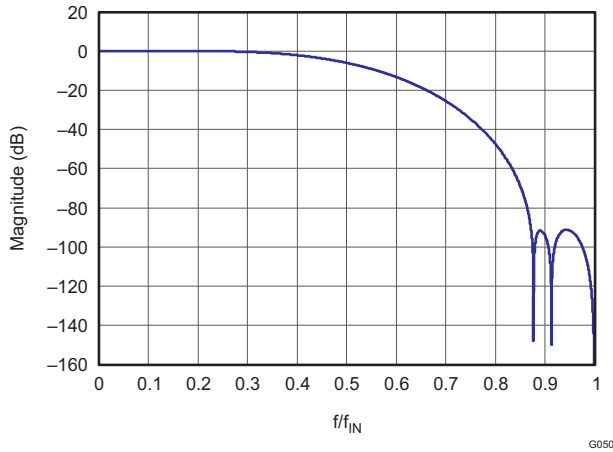
The DAC37J82/DAC38J82 includes a no interpolation 1x mode. However, the input data rate in this mode is limited to 1230MSPS. See more details in Table 10 and .

The DAC37J82/DAC38J82 also has a 9-tap inverse sinc filter (FIR4) that runs at the DAC update rate ( $f_{DAC}$ ) that can be used to flatten the frequency response of the sample-and-hold output. The DAC sample-and-hold output sets the output current and holds it constant for one DAC clock cycle until the next sample, resulting in the well-known  $\sin(x)/x$  or  $\text{sinc}(x)$  frequency response (Figure 68, red line). The inverse sinc filter response (Figure 68, blue line) has the opposite frequency response from 0 to  $0.4 \times f_{DAC}$ , resulting in the combined response (Figure 68, green line). Between 0 to  $0.4 \times f_{DAC}$ , the inverse sinc filter compensates the sample-and-hold roll-off with less than 0.03 dB error.

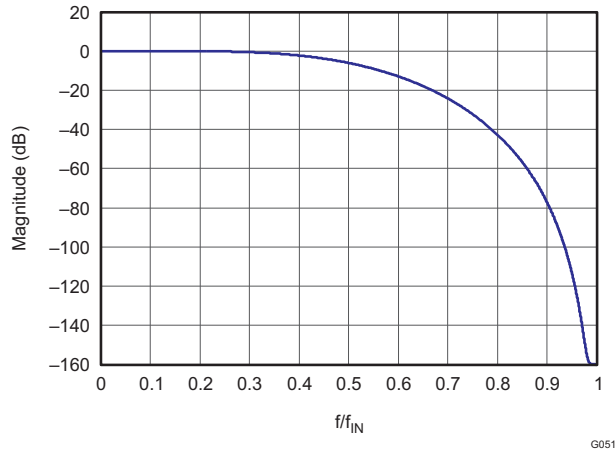
The inverse sinc filter has a gain  $> 1$  at all frequencies. Therefore, the signal input to FIR4 must be reduced from full scale to prevent saturation in the filter. The amount of back-off required depends on the signal frequency, and is set such that at the signal frequencies the combination of the input signal and filter response is less than 1 (0 dB). For example, if the signal input to FIR4 is at  $0.25 \times f_{DAC}$ , the response of FIR4 is 0.9 dB, and the signal must be backed off from full scale by 0.9 dB to avoid saturation. The gain function in the QMC blocks can be used to reduce the amplitude of the input signal. The advantage of FIR4 having a positive gain at all frequencies is that the user is then able to optimize the back-off of the signal based on its frequency.

The filter taps for all digital filters are listed in Table 14. Note that the loss of signal amplitude may result in lower SNR due to decrease in signal amplitude.

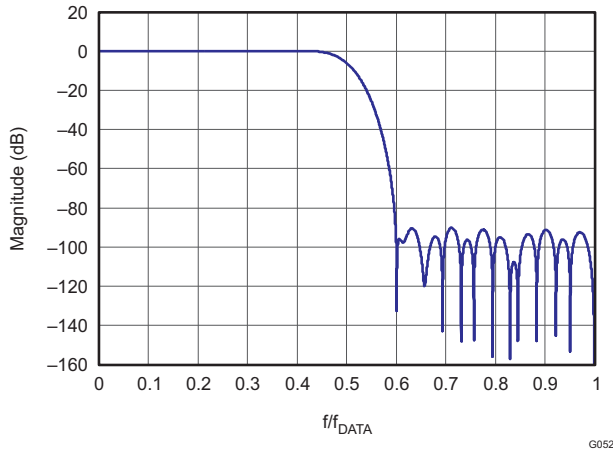




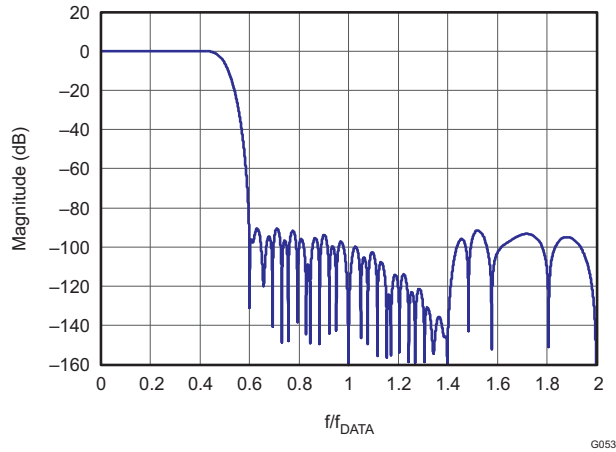
**Figure 62. Magnitude Spectrum for FIR2**



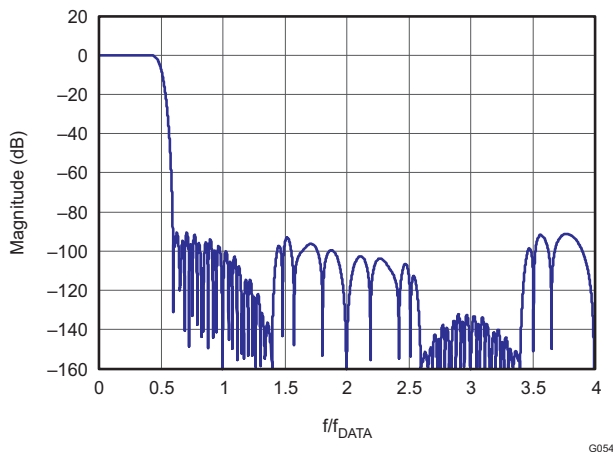
**Figure 63. Magnitude Spectrum for FIR3**



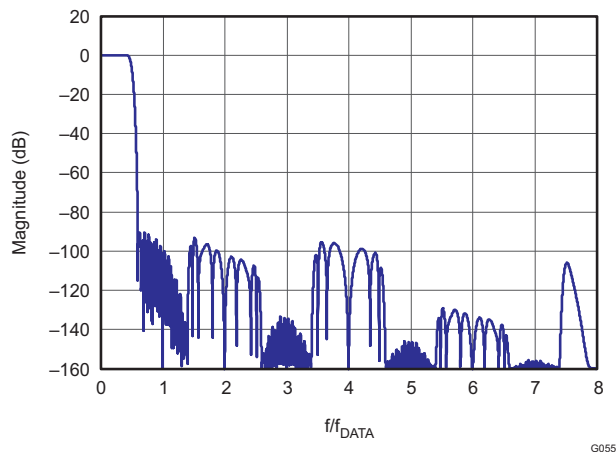
**Figure 64. 2x Interpolation Composite Response**



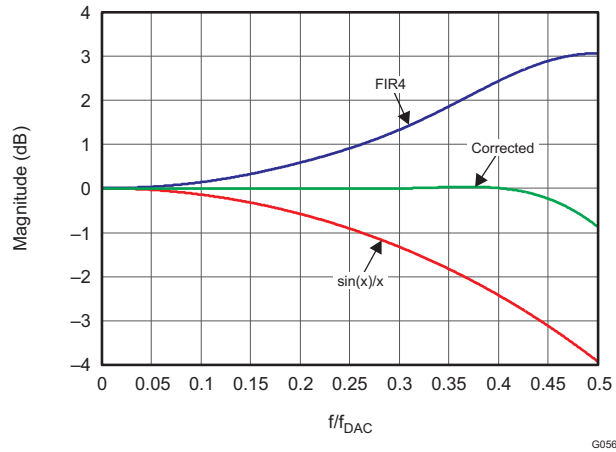
**Figure 65. 4x Interpolation Composite Response**



**Figure 66. 8x Interpolation Composite Response**



**Figure 67. 16x Interpolation Composite Response**



**Figure 68. Magnitude Spectrum for Inverse Sinc Filter**

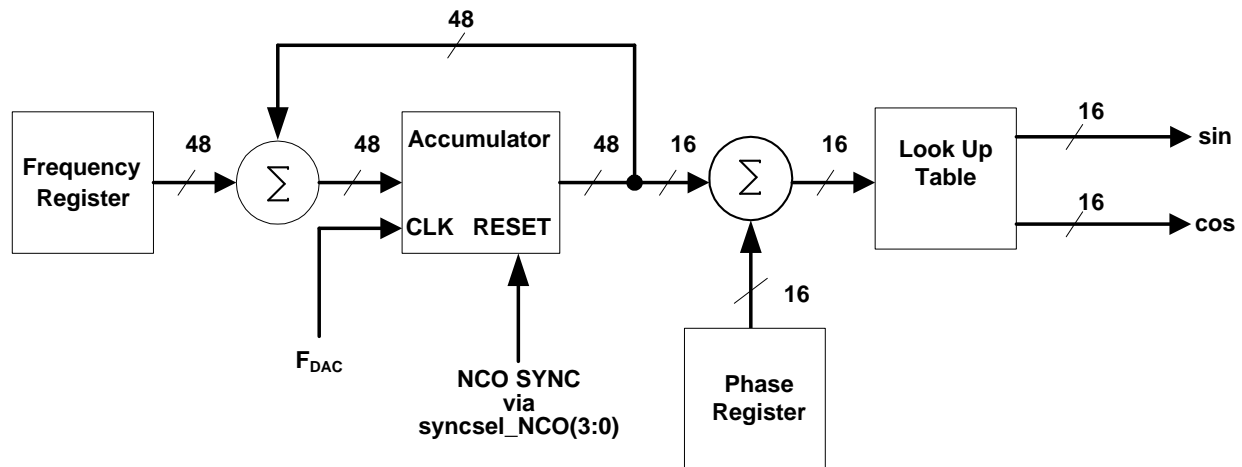
**Table 13. FIR Filter Coefficients**

2x INTERPOLATING HALF-BAND FILTERS								NON-INTERPOLATING INVERSE-SINC FILTER	
FIR0		FIR1		FIR2		FIR3		FIR4	
59 Taps		23 Taps		11 Taps		11 Taps		9 Taps	
6	6	-12	-12	29	29	3	3	1	1
0	0	0	0	0	0	0	0	-4	-4
-19	-19	84	84	-214	-214	-25	-25	13	13
0	0	0	0	0	0	0	0	-50	-50
47	47	-336	-336	1209	1209	150	150	<b>592</b> <sup>(1)</sup>	
0	0	0	0	<b>2048</b> <sup>(1)</sup>		<b>256</b> <sup>(1)</sup>			
-100	-100	1006	1006						
0	0	0	0						
192	192	-2691	-2691						
0	0	0	0						
-342	-342	10141	10141						
0	0	<b>16384</b> <sup>(1)</sup>							
572	572								
0	0								
-914	-914								
0	0								
1409	1409								
0	0								
-2119	-2119								
0	0								
3152	3152								
0	0								
-4729	-4729								
0	0								
7420	7420								
0	0								
-13334	-13334								
0	0								
41527	41527								
<b>65536</b> <sup>(1)</sup>									

(1) Center taps are highlighted in **BOLD**.

### 7.3.11 Full Complex Mixer

The DAC37J82/DAC38J82 has two full complex mixer (FMIX) blocks with independent Numerically Controlled Oscillators (NCO) that enables flexible frequency placement without imposing additional limitations in the signal bandwidth. The NCOs have 48-bit frequency registers (*phaseaddab* (47:0) and *phaseaddcd* (47:0)) and 16-bit phase registers (*phaseoffsetab* (15:0) and *phaseoffsetcd* (15:0)) that generate the sine and cosine terms for the complex mixing. The NCO block diagram is shown in [Figure 69](#).


**Figure 69. NCO Block Diagram**

Synchronization of the NCOs occurs by resetting the NCO accumulators to zero. The synchronization source is selected by **syncsel\_NCO** (3:0) in **config31**. The frequency word in the **phaseaddab** (47:0) and **phaseaddcd** (47:0) registers is added to the accumulators every clock cycle,  $f_{DAC}$ . The output frequency of the NCO is

$$f_{NCO} = \frac{freq \times f_{NCO\_CLK}}{2^{48}}$$

Treating the two complex channels in the DAC37J82/DAC38J82 as complex vectors of the form  $I + jQ$ , the output of FMIX  $I_{OUT}(t)$  and  $Q_{OUT}(t)$  is

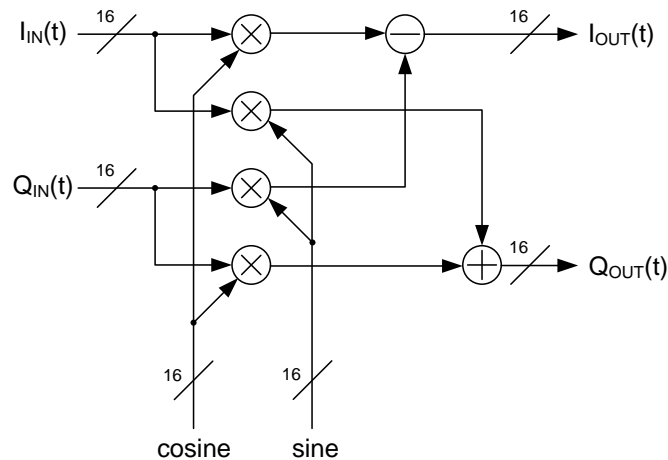
$$I_{OUT}(t) = (I_{IN}(t)\cos(2\pi f_{NCO}t + \delta) - Q_{IN}(t)\sin(2\pi f_{NCO}t + \delta)) \times 2^{(mixer\_gain - 1)}$$

$$Q_{OUT}(t) = (I_{IN}(t)\sin(2\pi f_{NCO}t + \delta) + Q_{IN}(t)\cos(2\pi f_{NCO}t + \delta)) \times 2^{(mixer\_gain - 1)}$$

where  $t$  is the time since the last resetting of the NCO accumulator,  $\delta$  is the phase offset value and  $mixer\_gain$  is either 0 or 1.  $\delta$  is given by:

$$\delta = 2\pi \times phase\_offsetAB/CD (15:0)/2^{16}$$

A block diagram of the mixer is shown in [Figure 70](#). The complex mixer can be used as a digital quadrature modulator with a real output simply by only using the  $I_{OUT}$  branch and ignoring the  $Q_{OUT}$  branch.


**Figure 70. Complex Mixer Block Diagram**

The maximum output amplitude of FMIX occurs if  $I_{IN}(t)$  and  $Q_{IN}(t)$  are simultaneously full scale amplitude and the sine and cosine arguments are equal to  $2\pi \times f_{NCO}t + \delta (2N-1) \times \pi/4$  ( $N = 1, 2, \dots$ ).

With **mixer\_gain** = 0 in *config2*, the gain through FMIX is  $\sqrt{2}/2$  or  $-3$  dB. This loss in signal power is in most cases undesirable, and it is recommended that the gain function of the QMC block be used to increase the signal by 3 dB to compensate. With **mixer\_gain** = 1, the gain through FMIX is  $\sqrt{2}$  or  $+3$  dB, which can cause clipping of the signal if  $I_{IN}(t)$  and  $Q_{IN}(t)$  are simultaneously near full scale amplitude and should therefore be used with caution.

### 7.3.12 Coarse Mixer

In addition to the full complex mixers the DAC37J82/DAC38J82 also has a coarse mixer block capable of shifting the input signal spectrum by the fixed mixing frequencies  $\pm n \times f_s/8$ . Using the coarse mixer instead of the full mixers will result in lower power consumption.

Treating the two complex channels as complex vectors of the form  $I(t) + j Q(t)$ , the outputs of the coarse mixer,  $I_{OUT}(t)$  and  $Q_{OUT}(t)$  are equivalent to:

$$I_{OUT}(t) = I(t)\cos(2\pi f_{CMIX}t) - Q(t)\sin(2\pi f_{CMIX}t)$$

$$Q_{OUT}(t) = I(t)\sin(2\pi f_{CMIX}t) + Q(t)\cos(2\pi f_{CMIX}t)$$

where  $f_{CMIX}$  is the fixed mixing frequency selected by **cmix**=(*fs8*, *fs4*, *fs2*, *fsm4*). The mixing combinations are described in [Table 14](#).

**Table 14. Coarse Mixer Combinations**

cmix(3:0)	Fs/8 MIXER cmix(3)	Fs/4 MIXER cmix(2)	Fs/2 MIXER cmix(1)	-Fs/4 MIXER cmix(0)	MIXING MODE
0000	Disabled	Disabled	Disabled	Disabled	No mixing
0001	Disabled	Disabled	Disabled	Enabled	$-Fs/4$
0010	Disabled	Disabled	Enabled	Disabled	$Fs/2$
0100	Disabled	Enabled	Disabled	Disabled	$+Fs/4$
1000	Enabled	Disabled	Disabled	Disabled	$+Fs/8$
1010	Enabled	Disabled	Enabled	Disabled	$-3Fs/8$
1100	Enabled	Enabled	Disabled	Disabled	$+3Fs/8$
1110	Enabled	Enabled	Enabled	Disabled	$-Fs/8$
All others	—	—	—	—	Not recommended

### 7.3.13 Dithering

The DAC37J82/DAC38J82 supports the addition of a band limited dither to the DAC output after the complex mixer. This feature is enabled by set **dither\_ena** to “1” and can be useful in reducing the high order harmonics. The generated dithering sequence can be optionally up-converted to an offset of  $F_s/2$  by setting **dither\_mixer\_ena** to “1”. The added dithering sequence has variable amplitude in 6 dB steps via **dither\_sra\_sel**.

### 7.3.14 Complex Summation

The DAC37J82/DAC38J82 has a complex summation block which is to sum channel A with channel C, channel B with Channel D, and the resulted complex summation are divided by 2 and sent via channel A and channel B. This feature is enabled by set **output\_sum** to “1” and can be useful for multi-band application.

### 7.3.15 Quadrature Modulation Correction (QMC)

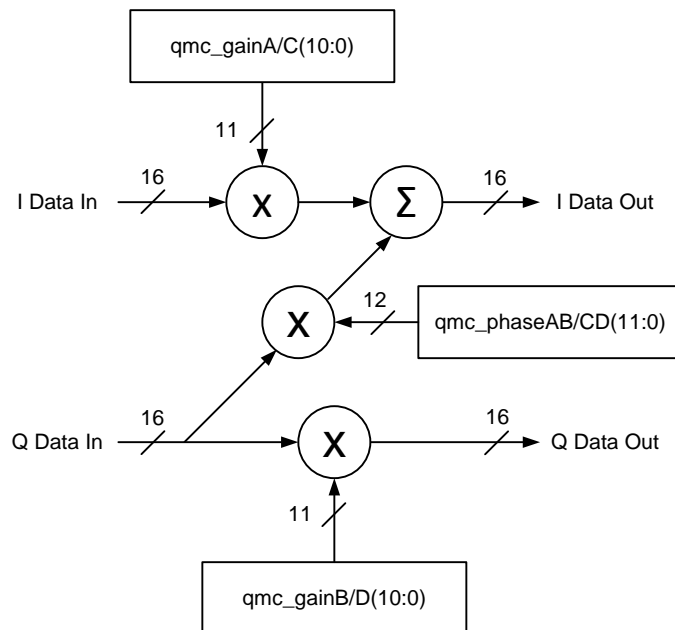
#### 7.3.15.1 Gain and Phase Correction

The DAC37J82/DAC38J82 includes a Quadrature Modulator Correction (QMC) block. The QMC blocks provide a mean for changing the gain and phase of the complex signals to compensate for any I and Q imbalances present in an analog quadrature modulator. The block diagram for the QMC block is shown in [Figure 71](#). The QMC block contains 3 programmable parameters.

Registers *mem\_qmc\_gaina* (10:0) and *mem\_qmc\_gainb* (10:0) controls the I and Q path gains and is an 11-bit unsigned value with a range of 0 to 1.9990 and the default gain is 1.0000. The implied decimal point for the multiplication is between bit 9 and bit 10. The resolution allows suppression to > 65 dBc for a frequency independent IQ imbalance (the fine delay FIR block also contains gain control through the filter taps or inverse gain block that allows control with > 20 bits resolution, which can be used to improve the sideband suppression).

Register *mem\_qmc\_phaseab* (11:0) control the phase imbalance between I and Q and are a 12-bit values with a range of –0.5 to approximately 0.49975. The QMC phase term is not a direct phase rotation but a constant that is multiplied by each "Q" sample then summed into the "I" sample path. This is an approximation of a true phase rotation in order to keep the implementation simple. The resolution of the phase term allows suppression to > 80 dBc for a frequency independent IQ imbalance.

LO feed-through can be minimized by adjusting the DAC offset feature described below.



**Figure 71. QMC Block Diagram**

### 7.3.15.2 Offset Correction

Registers *mem\_qmc\_offseta* (12:0) and *mem\_qmc\_offsetb* (12:0) can be used to independently adjust the DC offsets of each channel. The offset values are represented in 2s-complement format with a range from –4096 to 4095. The LSB resolution of the offset allows LO suppression to better than 90 dBFS.

The offset value adds a digital offset to the digital data before digital-to-analog conversion. Since the offset is added directly to the data it may be necessary to back off the signal to prevent saturation. Both data and offset values are LSB aligned.



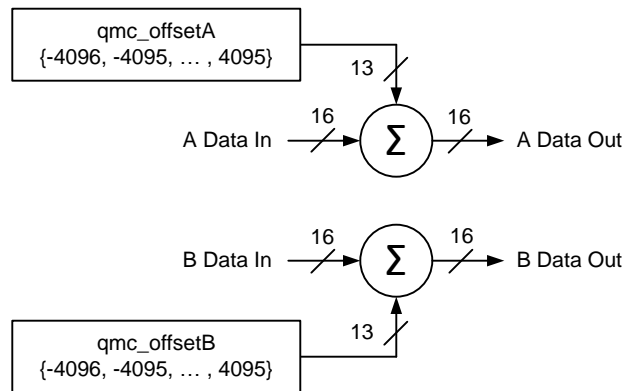


Figure 72. Digital Offset Block Diagram

### 7.3.16 Group Delay Correction Block

A complex transmitter system typically is consisted of a DAC, reconstruction filter network, and I/Q modulator. Besides the gain and phase mismatch contribution, there could also be timing mismatch contribution from each components. For instance, the timing mismatch could come from the PCB trace length variation between the I and Q channels and the group delay variation from the reconstruction filter. This timing mismatch in the complex transmitter system creates phase mismatch that varies linearly with respect to frequency. To compensate for the I/Q imbalances due to this mismatch, the DAC37J82/DAC38J82 has group delay correction block for each DAC channel.

The DAC38J82/DAC37J82 incorporates 2 FIR filters for small fractional group delay and 4 FIR filters for large fractional group delay. The input data to this block consists of 2, complex data (I/Q) channels i.e. 4 buses of 16-bit data. Control bits from configuration registers select the data path for all inputs through this block. Each input can either go through the small fractional delay filter (while its conjugate part goes through the matched delay line) or bypass the small fractional delay sub-block completely (matched delay line is bypassed for the conjugate part). The input to the large fractional delay F can either come from the output of small fractional delay sub-block or the original input to the block. The large fractional delay sub-block can also be completely bypassed if desired.

The DAC38J82/DAC37J82 also include an integer delay block following each large fractional group delay filter, which can further delay the DAC output by  $[0-3] \times T_{dac}$ . Channel A&B share the same control signal **output\_delayab**, and channel C&D share the same control signal **output\_delaycd**, which means that channel A&B have the same integer delay, and channel C&D have the same integer delay.

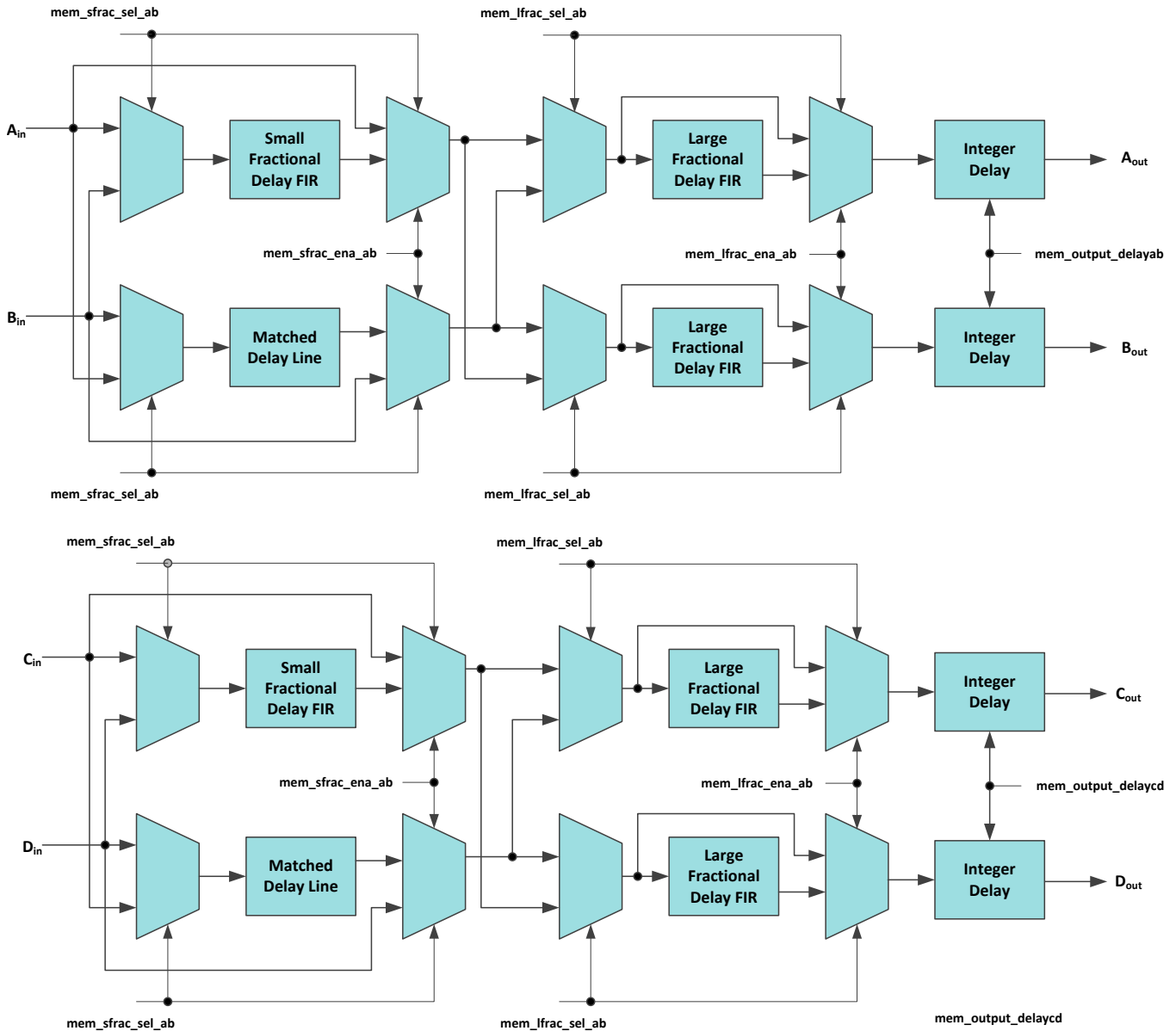


Figure 73. Diagram of Group Delay Correction

### 7.3.16.1 Fine Fractional Delay FIR Filter

The coefficients of the FIR filters for small fractional delay are programmable to user defined values which allows users to implement their own filter transfer functions. Filter designs supporting group delay variation in the range  $[0.002 \ 0.198] \times T_{dac}$ , where T is the time period of DAC Clock, is listed in Table 16. The bit widths of all coefficients are fixed, which puts limits on the range of values each coefficient can acquire.

Table 15. Small Fractional Delay FIR Coefficient Range

COEFFICIENT	RANGE
C0	[-2,1]
C1	[-16,15]
C2	[-128,127]
C3	[-512,511]
C4	[-262144,262143]

**Table 15. Small Fractional Delay FIR Coefficient Range (continued)**

COEFFICIENT	RANGE
C5	[-512,511]
C6	[-256,255]
C7	[-64,63]
C8	[-16,15]
C9	[-2,1]

**Table 16. Example Coefficient Sets for the Small Fractional Delay**

C0	C1	C2	C3	C4	C5	C6	C7	C8	C9	InvGain NUMERATOR	DELAY [Tdac]
1	-12	64	-273	195897	393	-137	43	-9	1	5479	0.002
1	-12	64	-272	97872	393	-137	43	-9	1	10963	0.004
1	-12	64	-271	65138	394	-137	43	-9	1	16465	0.006
1	-12	64	-270	48873	395	-137	43	-9	1	21936	0.008
1	-12	64	-270	39068	395	-137	43	-9	1	27431	0.01
1	-12	64	-269	32555	396	-137	43	-9	1	32904	0.012
1	-12	63	-269	27892	396	-137	43	-9	1	38390	0.014
1	-12	63	-268	24387	397	-138	43	-9	1	43889	0.016
1	-12	63	-267	21666	398	-138	43	-9	1	49377	0.018
1	-12	63	-267	19496	398	-138	43	-9	1	54850	0.02
1	-12	63	-266	17722	399	-138	43	-9	1	60309	0.022
1	-12	63	-265	16235	400	-138	43	-9	1	65797	0.024
1	-12	63	-265	14981	400	-138	43	-9	1	71274	0.026
1	-12	63	-264	13907	401	-138	43	-9	1	76734	0.028
1	-12	63	-263	12973	402	-138	43	-9	1	82210	0.03
1	-12	63	-263	12159	402	-138	43	-9	1	87674	0.032
1	-12	63	-262	11439	403	-138	43	-9	1	93134	0.034
1	-12	63	-262	10798	404	-138	43	-9	1	98608	0.036
1	-12	62	-261	10227	404	-139	43	-9	1	104075	0.038
1	-12	62	-261	9714	405	-139	43	-9	1	109510	0.04
1	-12	62	-260	9246	406	-139	43	-9	1	114974	0.042
1	-12	62	-259	8823	406	-139	43	-9	1	120415	0.044
1	-12	62	-259	8435	407	-139	43	-9	1	125878	0.046
1	-12	62	-258	8080	408	-139	43	-9	1	131312	0.048
1	-12	62	-257	7754	408	-139	43	-9	1	136748	0.05
1	-12	62	-257	7454	409	-139	43	-9	1	142161	0.052
1	-12	62	-256	7174	410	-139	43	-9	1	147593	0.054
1	-12	62	-256	6916	411	-139	43	-9	1	152998	0.056
1	-12	62	-255	6675	411	-139	43	-9	1	158416	0.058
1	-12	62	-255	6450	412	-139	43	-9	1	163830	0.06
1	-12	61	-254	6239	413	-140	43	-9	1	169280	0.062
1	-12	61	-253	6042	413	-140	43	-9	1	174677	0.064
1	-12	61	-253	5856	414	-140	43	-9	1	180098	0.066
1	-12	61	-252	5683	415	-140	43	-9	1	185416	0.068
1	-12	61	-252	5518	416	-140	43	-9	1	190820	0.07
1	-12	61	-251	5363	416	-140	43	-9	1	196189	0.072
1	-12	61	-251	5215	417	-140	43	-9	1	201604	0.074
1	-12	61	-250	5076	418	-140	43	-9	1	206927	0.076

**Table 16. Example Coefficient Sets for the Small Fractional Delay (continued)**

C0	C1	C2	C3	C4	C5	C6	C7	C8	C9	InvGain NUMERATOR	DELAY [Tdac]
1	-12	61	-249	4944	419	-140	43	-9	1	212244	0.078
1	-12	61	-249	4819	419	-140	43	-9	1	217621	0.08
1	-12	61	-248	4700	420	-140	43	-9	1	222907	0.082
1	-12	61	-248	4586	421	-141	43	-9	1	228310	0.084
1	-12	60	-247	4477	422	-141	43	-9	1	233676	0.086
1	-12	60	-247	4375	422	-141	43	-9	1	238981	0.088
1	-12	60	-246	4275	423	-141	43	-9	1	244310	0.09
1	-12	60	-246	4181	424	-141	44	-9	1	249533	0.092
1	-12	60	-245	4090	425	-141	44	-9	1	254803	0.094
1	-12	60	-245	4003	425	-141	44	-9	1	260175	0.096
1	-12	60	-244	3920	426	-141	44	-9	1	265384	0.098
1	-12	60	-243	3840	427	-141	44	-9	1	270600	0.1
1	-12	60	-243	3763	428	-141	44	-9	1	275884	0.102
1	-12	60	-242	3690	429	-141	44	-9	1	281011	0.104
1	-12	60	-242	3619	429	-142	44	-9	1	286408	0.106
1	-12	60	-241	3550	430	-142	44	-9	1	291619	0.108
1	-12	60	-241	3484	431	-142	44	-9	1	296860	0.11
1	-12	59	-240	3421	432	-142	44	-9	1	302037	0.112
1	-12	59	-240	3360	433	-142	44	-9	1	307222	0.114
1	-12	59	-239	3300	433	-142	44	-9	1	312498	0.116
1	-12	59	-239	3243	434	-142	44	-9	1	317675	0.118
1	-12	59	-238	3188	435	-142	44	-9	1	322736	0.12
1	-12	59	-238	3134	436	-142	44	-9	1	327960	0.122
1	-12	59	-237	3082	437	-142	44	-9	1	333046	0.124
1	-12	59	-237	3033	438	-143	44	-9	1	338186	0.126
1	-12	59	-236	2984	438	-143	44	-9	1	343378	0.128
1	-11	59	-236	2937	439	-143	44	-9	1	348391	0.13
1	-11	59	-235	2891	440	-143	44	-9	1	353437	0.132
1	-11	59	-235	2847	441	-143	44	-9	1	358511	0.134
1	-11	58	-234	2804	442	-143	44	-9	1	363611	0.136
1	-11	58	-234	2762	443	-143	44	-9	1	368730	0.138
1	-11	58	-233	2722	443	-143	44	-9	1	373735	0.14
1	-11	58	-233	2682	444	-143	44	-9	1	378879	0.142
1	-11	58	-232	2644	445	-143	44	-9	1	383753	0.144
1	-11	58	-232	2607	446	-143	44	-9	1	388755	0.146
1	-11	58	-231	2570	447	-144	44	-9	1	393889	0.148
1	-11	58	-231	2535	448	-144	44	-9	1	398864	0.15
1	-11	58	-230	2501	449	-144	44	-9	1	403662	0.152
1	-11	58	-230	2467	449	-144	44	-9	1	408889	0.154
1	-11	58	-229	2435	450	-144	44	-9	1	413614	0.156
1	-11	58	-229	2403	451	-144	44	-9	1	418613	0.158
1	-11	58	-228	2372	452	-144	44	-9	1	423400	0.16
1	-11	57	-228	2342	453	-144	44	-9	1	428468	0.162
1	-11	57	-227	2313	454	-144	44	-9	1	433135	0.164
1	-11	57	-227	2284	455	-144	44	-9	1	438083	0.166
1	-11	57	-226	2256	456	-145	44	-9	1	442963	0.168

**Table 16. Example Coefficient Sets for the Small Fractional Delay (continued)**

C0	C1	C2	C3	C4	C5	C6	C7	C8	C9	InvGain NUMERATOR	DELAY [Tdac]
1	-11	57	-226	2228	457	-145	44	-9	1	447952	0.17
1	-11	57	-225	2202	458	-145	44	-9	1	452483	0.172
1	-11	57	-225	2175	459	-145	44	-9	1	457495	0.174
1	-11	57	-224	2150	459	-145	44	-9	1	462222	0.176
1	-11	57	-224	2125	460	-145	44	-9	1	467047	0.178
1	-11	57	-223	2100	461	-145	44	-9	1	471767	0.18
1	-11	57	-223	2076	462	-145	44	-9	1	476583	0.182
1	-11	57	-223	2053	463	-145	44	-9	1	481283	0.184
1	-11	57	-222	2030	464	-145	44	-9	1	485856	0.186
1	-11	57	-222	2008	465	-146	44	-9	1	490741	0.188
1	-11	56	-221	1986	466	-146	44	-9	1	495497	0.19
1	-11	56	-221	1964	467	-146	44	-9	1	500346	0.192
1	-11	56	-220	1943	468	-146	44	-9	1	504815	0.194
1	-11	56	-220	1923	469	-146	44	-9	1	509365	0.196
1	-11	56	-219	1903	470	-146	44	-9	1	513752	0.198

### 7.3.16.2 Coarse Fractional Delay FIR Filter

The coefficients of FIR filters for large fractional delay can only be chosen from a predefined set of values. Each set of values produces a specific delay with a step of  $1/8 \times T_{dac}$ . The value of coefficients as well as their resultant fractional delay is provided in [Table 17](#).

**Table 17. Available Coefficient Sets for Large Fractional Delay FIR**

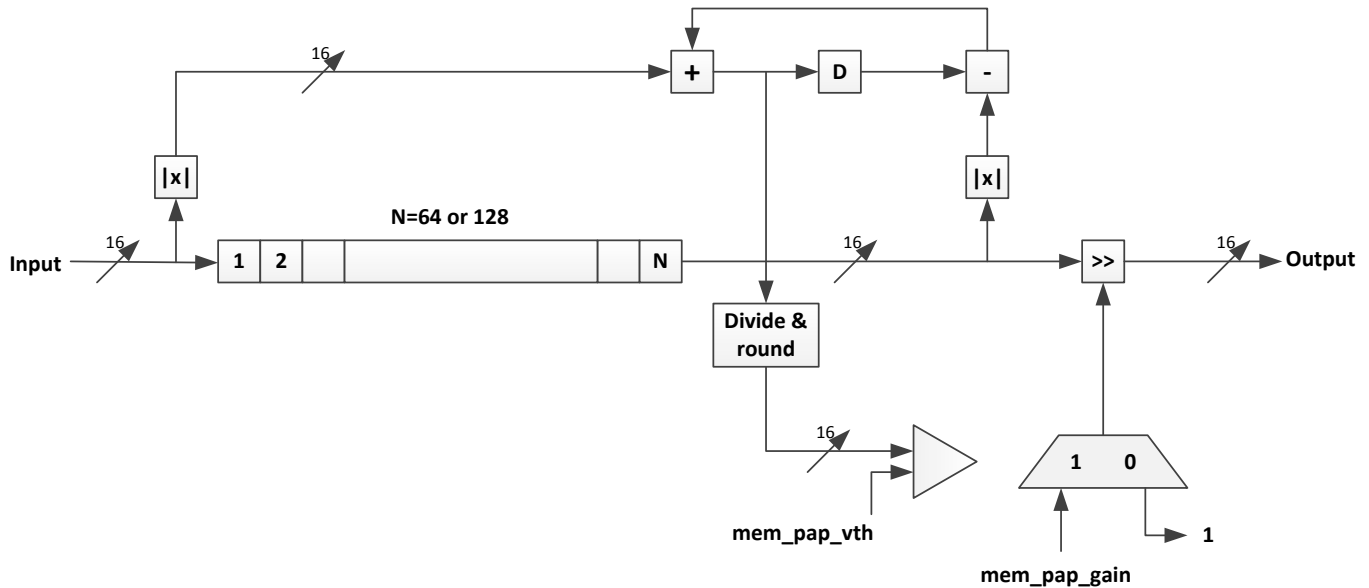
lfras_coefsel_x	C0	C1	C2	C3	C4	C5	C6	C7	InvGain NUMERATOR	DELAY [Tdac]
000	-1	9	-39	532	76	-24	7	-1	7503	0.1250
001	-1	8	-35	259	87	-25	7	-1	14028	0.2500
010	-1	7	-31	168	101	-26	7	-1	18725	0.3750
011	-1	7	-27	122	122	-27	7	-1	20764	0.5000
100	—	—	—	—	—	—	—	—	—	—
101	-1	7	-26	101	168	-31	7	-1	18725	0.6250
110	-1	7	-25	87	259	-35	8	-1	14028	0.7500
111	-1	7	-24	76	532	-39	9	-1	7503	0.8750

### 7.3.17 Output Multiplexer

The DAC37J82/DAC38J82 family provides four analog outputs and includes an output multiplexer before the digital to analog converters that allows any signal channel to be routed to any analog outputs. See [pathx\\_out\\_sel](#) for details on how to configure the cross-bar switches.

### 7.3.18 Power Measurement And Power Amplifier Protection

The DAC37J82/DAC38J82 provides an optional mechanism to protect the Power Amplifier (PA) in cases when the signal power shows some abnormality. For example, if the data clock is lost, the FIFO would automatically generate a single tone signal, which causes abnormally high average power and could be dangerous to the PA. In the PA protection mechanism, the signal power is monitored by maintaining an sliding window accumulation of last N samples. N is selectable to be 64 or 128 based on the setting of [pap\\_dlylen\\_sel](#). The average amplitude of input signal is computed by dividing accumulated value by the number of samples in the delay-line (N). The result is then compared against a threshold ([pap\\_vth](#)). If the threshold is violated, the delayed input signal is divided by a value chosen by [pap\\_gain](#), to form a scaled down version of the input signal. Since PAP output derives from a delay-line, there is deterministic latency of at least N cycles from the block input to block output. The PA protection is enabled by setting the [pap\\_ena](#) bit to "1".


**Figure 74. Diagram of Power Measurement and PA Protection Mechanism**

### 7.3.19 SerDes Test Modes

The DAC37J82/DAC38J82 supports a number of basic pattern generation and verification of SerDes via SIF. Three pseudo random bit stream (PRBS) sequences are available, along with an alternating 0/1 pattern and a 20-bit user-defined sequence. The  $2^7-1$ ,  $2^{31}-1$  or  $2^{23}-1$  sequences implemented can often be found programmed into standard test equipment, such as a Bit Error Rate Tester (BERT). Pattern generation and verification selection is via the **TESTPATT** fields of `rw_cfgrx0[14:12]`, as shown in [Table 18](#).

**Table 18. SerDes Test Pattern Selection**

TESTPATT	EFFECT
000	Test mode disabled.
001	Alternating 0/1 Pattern. An alternating 0/1 pattern with a period of 2UI.
010	Generate or Verify $2^7-1$ PRBS. Uses a 7-bit LFSR with feedback polynomial $x^7 + x^6 + 1$ .
011	Generate or Verify $2^{23}-1$ PRBS. Uses an ITU O.150 conformant 23-bit LFSR with feedback polynomial $x^{23} + x^{18} + 1$ .
100	Generate or Verify $2^{31}-1$ PRBS. Uses an ITU O.150 conformant 31-bit LFSR with feedback polynomial $x^{31} + x^{28} + 1$ .
101	User-defined 20-bit pattern. Uses the USR PATT IEEE1500 Tuning instruction field to specify the pattern. The default value is 0x666666.
11x	Reserved

Pattern verification compares the output of the serial to parallel converter with an expected pattern. When there is a mismatch, the **TESTFAIL** bit is driven high, which can be programmed to come out the ALARM pin by setting `dtest[3:0]` to "0011".

The DAC37J82/DAC38J82 also provide a number of advanced diagnostic capabilities controlled by the IEEE 1500 interface. These are:

- Accumulation of pattern verification errors;
- The ability to map out the width and height of the receive eye, known as Eye Scan;
- Real-time monitoring of internal voltages and currents;

The SerDes blocks support the following IEEE1500 instructions:

**Table 19. IEEE1500 Instruction for SerDes Receivers**

INSTRUCTION	OPCODE	DESCRIPTION
ws_bypass	0x00	Bypass. Selects a 1-bit bypass data register. Use when accessing other macros on the same IEEE1500 scan chain.
ws_cfg	0x35	Configuration. Write protection options for other instructions.
ws_core	0x30	Core. Fields also accessible via dedicated core-side ports.
ws_tuning	0x31	Tuning. Fields for fine tuning macro performance.
ws_debug	0x32	Debug. Fields for advanced control, manufacturing test, silicon characterization and debug
ws_unshadowed	0x34	Unshadowed. Fields for silicon characterization.
ws_char	0x33	Char. Fields used for eye scan.

The data for each SerDes instruction is formed by chaining together sub-components called head, body (receiver or transmitter) and tail. The DAC37J82/DAC38J82 uses two SerDes receiver blocks R0 and R1, each of which contains 4 receive lanes (channels), the data for each IEEE1500 instruction is formed by chaining **{head, receive lane 0, receive lane 1, receive lane 2, receive lane 3, tail}**. A description of bits in head, body and tail for each instruction is given as follows:

#### NOTE

All multi-bit signals in each chain are packed with bits reversed e.g.  $mpy[7:0]$  in `ws_core` head subchain is packed as `{retime, enpll,  $mpy[0:7]$ ,  $vrange, lb[0:1]$ }`. All DATA REGISTER READS from SerDes Block R0 should read 1 bit more than the desired number of bits and discard the first bit received on TDO e.g., to read 40-bit data from R0 block, 41 bits should be read off from TDO and the first bit received should be discarded. Similarly, any data written to SerDes Block R0 Data Registers should be prefixed with an extra 0.

**Table 20. ws\_cfg Chain**

FIELD	DESCRIPTION
<b>HEAD (STARTING FROM THE MSB OF CHAIN)</b>	
RETIME	No function.
CORE_WE	Core chain write enable.
<b>RECEIVER (FOR EACH LANE 0,1,2,3)</b>	
CORE_WE	Core chain write enable.
TUNING_WE	Tuning chain write enable.
DEBUG_WE	Reserved.
CHAR_WE	Char chain write enable.
UNSHADOWED_WE	Reserved.
<b>TAIL (ENDING WITH THE LSB OF CHAIN)</b>	
CORE_WE	Core chain write enable.
TUNING_WE	Tuning chain write enable.
DEBUG_WE	Reserved.
RETIME	No function.
<b>CHAIN LENGTH = 26 BITS</b>	

**Table 21. ws\_core Chain**

FIELD	DESCRIPTION
<b>HEAD (STARTING FROM THE MSB OF CHAIN)</b>	
RETIME	No function.
ENPLL	PLL enable.
MPY[7:0]	PLL multiply.
VRANGE	VCO range.
ENDIVCLK	Enable DIVCLK output

**Table 21. ws\_core Chain (continued)**

FIELD	DESCRIPTION
LB[1:0]	Loop bandwidth
<b>RECEIVER (FOR EACH LANE 0,1,2,3)</b>	
ENRX	Receiver enable.
SLEEPRX	Receiver sleep mode.
BUSWIDTH[2:0]	Bus width.
RATE[1:0]	Operating rate.
INVPAIR	Invert polarity.
TERM[2:0]	Termination.
ALIGN[1:0]	Symbol alignment.
LOS[2:0]	Loss of signal enable.
CDR[2:0]	Clock/data recovery.
EQ[2:0]	Equalizer.
EQHLD	Equalizer hold.
ENOC	Offset compensation.
LOOPBACK[1:0]	Loopback.
BSINRXP	Boundary scan initialization.
BSINRXN	Boundary scan initialization.
RESERVED	Reserved.
testpatt[2:0]	Testpattern selection.
TESTFAIL	Test failure (real time).
LOSDTCT	Loss of signal detected (real time).
BSRXP	Boundary scan data.
BSRXN	Boundary scan data.
OCIP	Offset compensation in progress.
EQOVER	Received signal over equalized.
EQUUNDER	Received signal under equalized.
LOSDTCT	Loss of signal detected (sticky).
SYNC	Re-alignment done, or aligned comma output (sticky)
RETIME	No function.
<b>TAIL (ENDING WITH THE LSB OF CHAIN)</b>	
CLKBYP[1:0]	Clock bypass.
SLEEPPLL	PLL sleep mode.
RESERVED	Reserved.
LOCK	PLL lock (real time).
BSINITCLK	Boundary scan initialization clock.
ENBSTX	Enable Tx boundary scan.
ENBSRX	Enable Rx boundary scan.
ENBSPT	Rx pulse boundary scan.
RESERVED	Reserved.
NEARLOCK	PLL near to lock.
UNLOCK	PLL lock (sticky).
CFG OVR	Configuration over-ride.
RETIME	No function.
<b>CHAIN LENGTH = 196 BITS</b>	



**Table 22. ws\_tuning Chain**

FIELD	DESCRIPTION
<b>HEAD (STARTING FROM THE MSB OF CHAIN)</b>	
RETIME	No function.
<b>RECEIVER (FOR EACH LANE 0,1,2,3)</b>	
PATTERRTHR[2:0]	Resync error threshold.
PATT TIMER	PRBS Timer.
RXDSEL[3:0]	Status select.
ENCOR	Enable clear-on-read for error counter.
EQZERO[4:0]	EQZ OVRi Equalizer zero.
EQZ OVR	Equalizer zero over-ride.
EQLEVEL[15:0]	EQ OVRi Equalizer gain observe or set.
EQ OVR	Equalizer over-ride.
EQBOOST[1:0]	Equalizer gain boost.
RXASEL[2:0]	Selects amux output.
<b>TAIL (ENDING WITH THE LSB OF CHAIN)</b>	
ASEL[3:0]	Selects amux output.
USR PATT[19:0]	User-defined test pattern.
RETIME	No function.
<b>CHAIN LENGTH = 174 BITS</b>	

**Table 23. ws\_char Chain**

FIELD	DESCRIPTION
<b>HEAD (STARTING FROM THE MSB OF CHAIN)</b>	
RETIME	No function.
<b>RECEIVER (FOR EACH LANE 0,1,2,3)</b>	
TESTFAIL	Test failure (sticky).
ECOUNT[11:0]	Error counter.
ESWORD[7:0]	Eye scan word masking.
ES[3:0]	Eye scan.
ESPO[6:0]	Eye scan phase offset.
ES BIT SELECT[4:0]	Eye scan compare bit select.
ESVO[5:0]	Eye scan voltage offset.
ESVO OVR	Eye scan voltage offset override.
ESLEN[1:0]	Eye scan run length.
ESRUN	Eye scan run.
ESDONE	Eye scan done.
<b>TAIL (ENDING WITH THE LSB OF CHAIN)</b>	
RETIME	No function.
<b>CHAIN LENGTH = 194 BITS</b>	

### 7.3.20 Error Counter

All receive channels include a 12-bit counter for accumulating pattern verification errors. This counter is accessible via the ECOUNT IEEE1500 Char field. It is an essential part of the eye scan capability (see next section), though can be used independently of this..

The counter increments once for every cycle that the TESTFAIL bit is detected. The counter will not increment when at its maximum value (i.e., all 1s). When an IEEE1500 capture is performed, the count value is loaded into the ECOUNT scan elements (so that it can be scanned out), and the counter is then reset, provided ENCOR is set high.

ECOUNT can be used to get a measure of the bit error rate. However, as the error rate increases, it will become less accurate due to limitations of the pattern verification capabilities. Specifically, the pattern verifier checks multiple bits in parallel (as determined by the Rx bus width), and it is not possible to distinguish between 1 or more errors in this.

### 7.3.21 Eye Scan

All receive channels provide features which facilitate mapping the received data eye or extracting a symbol response. A number of fields accessible via the IEEE1500 Char scan chain allow the required low level data to be gathered. The process of transforming this data into a map of the eye or a symbol response must then be performed externally, typically in software.

The basic principle used is as follows:

- Enable dedicated eye scan input samplers, and generate an error when the value sampled differs from the normal data sample;
- Apply a voltage offset to the dedicated eye scan input samplers, to effectively reduce their sensitivity;
- Apply a phase offset to adjust the point in the eye that the dedicated eye scan data samples are taken;
- Reset the error counter to remove any false errors accumulated as a result of the voltage or phase offset adjustments;
- Run in this state for a period of time, periodically checking to see if any errors have occurred;
- Change voltage and/or phase offset, and repeat.

Alternatively, the algorithm can be configured to optimize the voltage offset at a specified phase offset, over a specified time interval.

Eye scan can be used in both synchronous and asynchronous systems, while receiving normal data traffic. The IEEE1500 Char fields used to directly control eye scan and symbol response extraction are ES, ESWORD, ES BIT SELECT, ESLEN, ESPO, ESVO, ESVO OVR, ESRUN and ESDONE, see [Table 23](#). Eye scan errors are accumulated in ECOUNT.

The required eyescan mode is selected via the ES field, as shown in [Table 24](#). When enabled, only data from the bit position within the 20-bit word specified via ES BIT SELECT is analyzed. In other words, only eye scan errors associated with data output at this bit position will accumulate in ECOUNT. The maximum legal ES BIT SELECT is 10011.

**Table 24. Eye Scan Mode Selection**

ES[3:0]	EFFECT
0000	Disabled. Eye scan is disabled.
0x01	Compare. Counts mismatches between the normal sample and the eye scan sample if ES[2] = 0, and matches otherwise.
0x10	Compare zeros. As ES = 0x01, but only analyses zeros, and ignores ones.
0x11	Compare ones. As ES = 0x01, but only analyses ones, and ignores zeroes
0100	Count ones. Increments ECOUNT when the eye scan sample is a 1.
1x00	Average. Adjusts ESVO to the average eye opening over the time interval specified by ESLEN. Analyses zeroes when ES[2] = 0, and ones when ES[2] = 1.
1001 1110	Outer. Adjusts ESVO to the outer eye opening (i.e. lowest voltage zero, highest voltage 1) over the time interval specified by ESLEN. 1001 analyses zeroes, 1110 analyses ones.
1010 1101	Inner. Adjusts ESVO to the inner eye opening (i.e. highest voltage zero, lowest voltage 1) over the time interval specified by ESLEN. 1010 analyses zeroes, 1101 analyses ones.
1x11	Timed Compare. As ES = 001x, but analyses over the time interval specified by ESLEN. Analyses zeroes when ES[2] = 0, and ones when ES[2] = 1.

When ES[3] = 0, the selected analysis runs continuously. However, when ES[3] = 1, only the number of qualified samples specified by ESLEN, as shown in [Table 25](#). In this case, analysis is started by writing a 1 to ESRUN (it is not necessary to set it back to 0). When analysis completes, ESDONE will be set to 1.

**Table 25. Eye Scan Run Length**

ESLen	NUMBER OF SAMPLES ANALYZED
00	127
01	1023
10	8095
11	65535

When ESVO OVR = 1, the ESVO field determines the amount of offset voltage that is applied to the eye scan data samplers associated with rxpi and rxni. The amount of offset is variable between 0 and 300mV in increments of ~10mV, as shown in [Table 26](#). When ES[3] = 1, ESVO OVR must be 0 to allow the optimized voltage offset to be read back via ESVO.

**Table 26. Eye Scan Voltage Offset**

ESVO	OFFSET (mV)
100000	-310
..	..
111110	-20
111111	-10
000000	0
000001	10
000010	20
..	..
011111	300

The phase position of the samplers associated with rxpi and rxni, is controlled to a precision of 1/32UI. When ES is not 00, the phase position can be adjusted forwards or backwards by more than one UI using the ESPO field, as shown in [Table 27](#). In normal use, the range should be limited to  $\pm 0.5\text{UI}$  (+15 to -16 phase steps).

**Table 27. Eye Scan Phase Offset**

ESPO	OFFSET (1/32UI)
011111	+63
..	..
000001	+1
000000	0
111111	-1
..	..
100000	-64

### 7.3.22 JESD204B Pattern Test

The DAC37J82/DAC38J82 supports the following test patterns for JESD204B:

- Link layer test pattern
  - Verify repeating /D.21.5/ high frequency pattern for random jitter (RJ)
  - Verify repeating /K.28.5/ mixed frequency pattern for deterministic jitter (DJ)
  - Verify repeating initial lane alignment (ILA) sequence
  - RPAT, JSPAT or JTSPAT pattern can be verified using errors counter of 8b/10b errors produced over an amount of time to get an estimate of BER.
- Transport layer test pattern: implements a short transport layer pattern check based on  $F = 1, 2, 4$  or  $8$ . The short test pattern has a duration of one frame period and is repeated continuously for the duration of the test. Refer to JESD204B standard section 5.1.6 for more details.
  - $F = 1$  : Looks for a constant 0xF1.
  - $F = 2$  : Each frame should consist of 0xF1, 0xE2
  - $F = 4$  : Looks for a constant 0xF1, 0xE2, 0xD3, 0xC4
  - $F = 8$  : Each frame should consist of 0xF1, 0xE2, 0xD3, 0xC4, 0xB5, 0xA6, 0x97, 0x81

Users can select to output the internal data (ex, the 8b/10 decoder output, comma alignment output, lane alignment output, frame alignment output, descrambler output, etc ) of a JESD link for test purpose. See *jesd\_testbus\_sel* for configuration details.

### 7.3.23 Temperature Sensor

The DAC37J82/DAC38J82 incorporates a temperature sensor block which monitors the temperature by measuring the voltage across 2 transistors. The voltage is converted to an 8-bit digital word using a successive-approximation (SAR) analog to digital conversion process. The result is scaled, limited and formatted as a twos complement value representing the temperature in degrees Celsius.

The sampling is controlled by the serial interface signals SDENB and SCLK. If the temperature sensor is enabled (*tsense\_sleep* = "0" in register *config26*) a conversion takes place each time the serial port is written or read. The data is only read and sent out by the digital block when the temperature sensor is read in *memin\_tempdata* in *config7*. The conversion uses the first eight clocks of the serial clock as the capture and conversion clock, the data is valid on the falling eighth SCLK. The data is then clocked out of the chip on the rising edge of the ninth SCLK. No other clocks to the chip are necessary for the temperature sensor operation. As a result the temperature sensor is enabled even when the device is in sleep mode.

In order for the process described above to operate properly, the serial port read from *config6* must be done with an SCLK period of at least 1  $\mu$ s. If this is not satisfied the temperature sensor accuracy is greatly reduced.

### 7.3.24 Alarm Monitoring

The DAC37J82/DAC38J82 includes a flexible set of alarm monitoring that can be used to alert of a possible malfunction scenario. All the alarm events can be accessed either through the SIP registers and/or through the ALARM pin. Once an alarm is set, the corresponding alarm bit in register *config7bd* must be reset through the serial interface to allow further testing. The set of alarms includes the following conditions:

- *JESD alarms*
  - multiframe alignment\_error. Occurs when multiframe alignment fails.
  - frame alignment error. Occurs when multiframe alignment fails.
  - link configuration error. Occurs when there is wrong link configuration.
  - elastic buffer overflow. Occurs when bad RBD value is used.
  - elastic buffer match error. Occurs when the first non-/K/ doesn't match the programmed data.
  - code synchronization error.
  - 8b/10b not-in-table decode error.
  - 8b/10 disparity error.
  - alarm\_from\_shorttest. Occurs when fails the short pattern test.
- *SerDes alarms*
  - *memin\_rw\_losdct*. Occurs when there are loss of signal detect from SerDes lanes.



### 7.3.27 Reference Operation

The DAC37J82/DAC38J82 uses a bandgap reference and control amplifier for biasing the full-scale output current. The full-scale output current is set by applying an external resistor  $R_{BIAS}$  to pin BIASJ. The bias current  $I_{BIAS}$  through resistor  $R_{BIAS}$  is defined by the on-chip bandgap reference voltage and control amplifier. The default full-scale output current equals 64 times this bias current and can thus be expressed as:

$$IOUT_{FS} = 16 \times I_{BIAS} = 64 \times V_{EXTIO} / R_{BIAS}$$

The DAC37J82/DAC38J82 has a 4-bit coarse gain control *coarse\_dac(3:0)* in the *configtbd* register. Using gain control, the  $IOUT_{FS}$  can be expressed as:

$$IOUT_{FS} = (\text{coarse\_dac} + 1) / 16 \times I_{BIAS} \times 64 = (\text{coarse\_dac} + 1) / 16 \times V_{EXTIO} / R_{BIAS} \times 64$$

where  $V_{EXTIO}$  is the voltage at pin EXTIO. The bandgap reference voltage delivers an accurate voltage of 0.9V. This reference is active when *extref\_ena* = '0' in *configtbd*. An external decoupling capacitor  $C_{EXT}$  of 0.1  $\mu\text{F}$  should be connected externally to pin EXTIO for compensation. The bandgap reference can additionally be used for external reference operation. In that case, an external buffer with high impedance input should be applied in order to limit the bandgap load current to a maximum of 100 nA. The internal reference can be disabled and overridden by an external reference by setting the *extref\_ena* control bit. Capacitor  $C_{EXT}$  may hence be omitted. Pin EXTIO thus serves as either input or output node.

The full-scale output current can be adjusted from 30 mA down to 10 mA by varying resistor  $R_{BIAS}$  or changing the externally applied reference voltage.

### 7.3.28 Analog Outputs

The CMOS DACs consist of a segmented array of PMOS current sources, capable of sourcing a full-scale output current up to 30 mA. Differential current switches direct the current to either one of the complimentary output nodes IOUTP or IOUTN. Complimentary output currents enable differential operation, thus canceling out common mode noise sources (digital feed-through, on-chip and PCB noise), dc offsets, even order distortion components, and increasing signal output power by a factor of four.

The full-scale output current is set using external resistor  $R_{BIAS}$  in combination with an on-chip bandgap voltage reference source (+0.9 V) and control amplifier. Current  $I_{BIAS}$  through resistor  $R_{BIAS}$  is mirrored internally to provide a maximum full-scale output current equal to 16 times  $I_{BIAS}$ .

The relation between IOUTP and IOUTN can be expressed as:

$$IOUT_{FS} = IOUTP + IOUTN$$

We will denote current flowing into a node as –current and current flowing out of a node as +current. Since the output stage is a current source the current flows from the IOUTP and IOUTN pins. The output current flow in each pin driving a resistive load can be expressed as:

$$IOUTP = IOUT_{FS} \times \text{CODE} / 65536$$

$$IOUTN = IOUT_{FS} \times (65535 - \text{CODE}) / 65536$$

where CODE is the decimal representation of the DAC data input word.

For the case where IOUTP and IOUTN drive resistor loads  $R_L$  directly, this translates into single ended voltages at IOUTP and IOUTN:

$$VOUTP = IOUT1 \times R_L$$

$$VOUTN = IOUT2 \times R_L$$

Assuming that the data is full scale (65535 in offset binary notation) and the  $R_L$  is 25  $\Omega$ , the differential voltage between pins IOUTP and IOUTN can be expressed as:

$$VOUTP = 20\text{mA} \times 25 \Omega = 0.5 \text{ V}$$

$$VOUTN = 0\text{mA} \times 25 \Omega = 0 \text{ V}$$

$$V_{DIFF} = VOUTP - VOUTN = 0.5\text{V}$$

Note that care should be taken not to exceed the compliance voltages at node IOUTP and IOUTN, which would lead to increased signal distortion.

### 7.3.29 DAC Transfer Function

The DAC37J82/DAC38J82 can be easily configured to drive a doubly terminated 50 Ω cable using a properly selected RF transformer. Figure 77 and Figure 78 show the 50 Ω doubly terminated transformer configuration with 1:1 and 4:1 impedance ratio, respectively. Note that the center tap of the primary input of the transformer has to be grounded to enable a DC current flow. Applying a 20 mA full-scale output current would lead to a 0.5 V<sub>pp</sub> for a 1:1 transformer and a 1 V<sub>pp</sub> output for a 4:1 transformer. The low dc-impedance between IOUTP or IOUTN and the transformer center tap sets the center of the ac-signal to GND, so the 1 V<sub>pp</sub> output for the 4:1 transformer results in an output between –0.5 V and +0.5 V.

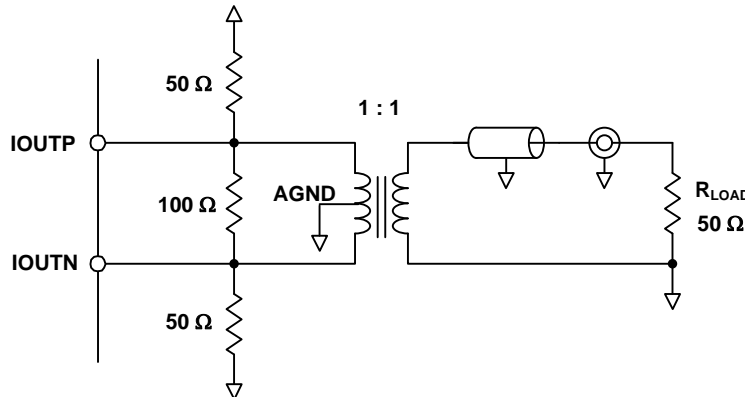


Figure 77. Driving a Doubly Terminated 50 Ω Cable Using a 1:1 Impedance Ratio Transformer

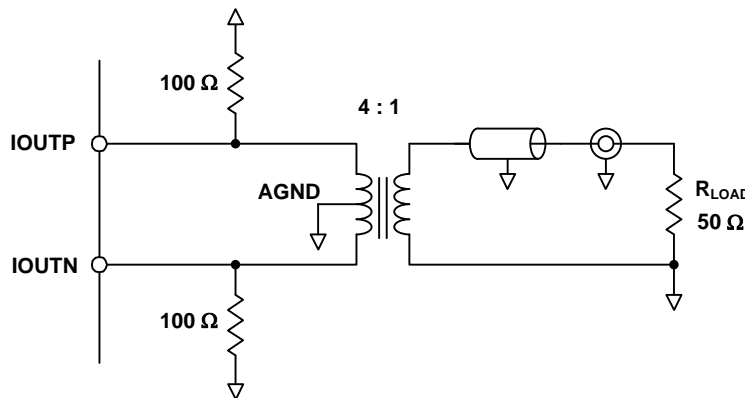


Figure 78. Driving a Doubly Terminated 50 Ω Cable Using a 4:1 Impedance Ratio Transformer

## 7.4 Device Functional Modes

### 7.4.1 Clocking Modes

The DAC37J82/DAC38J82 has a single differential clock DACCLKN/P to clock the DAC cores and internal digital logic. The DAC37J82/DAC38J82 DACCLK can be sourced directly or generated through an on-chip low-jitter phase-locked loop (PLL).

In those applications requiring extremely low noise it is recommended to bypass the PLL and source the DAC clock directly from a high-quality external clock to the DACCLK input. In most applications system clocking can be simplified by using the on-chip PLL to generate the DAC core clock while still satisfying performance requirements. In this case the DACCLK pins are used as the reference frequency input to the PLL.

#### 7.4.1.1 PLL Bypass Mode

In PLL bypass mode a high quality clock is sourced to the DACCLK inputs. This clock is used to directly clock the DAC37J82/DAC38J82 DAC cores. This mode gives the device best performance and is recommended for extremely demanding applications.

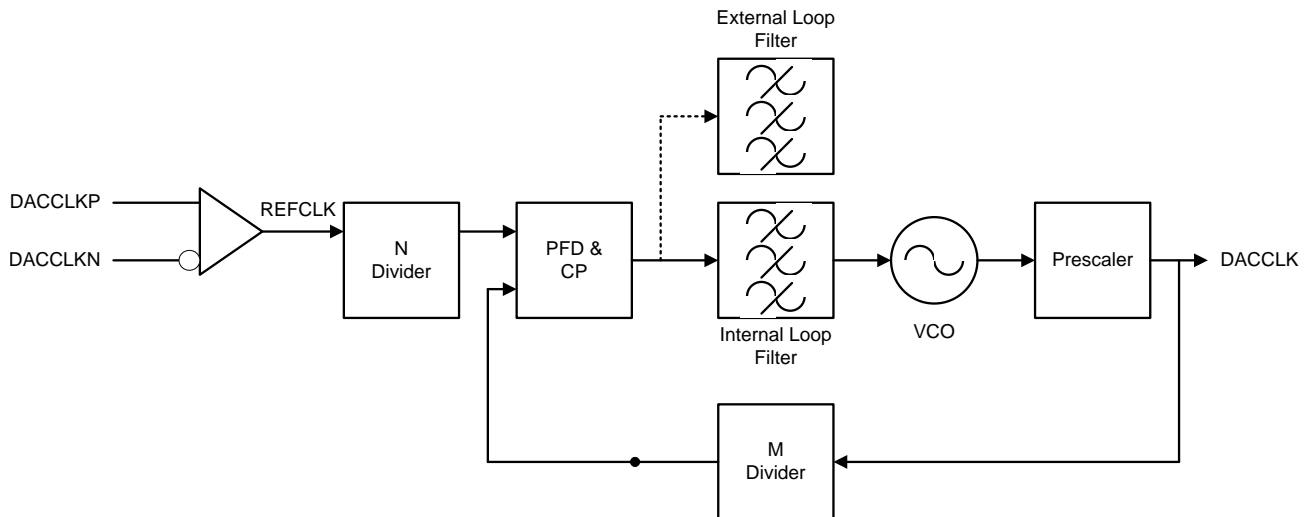
## Device Functional Modes (continued)

The bypass mode is selected by setting the following:

1. ***pll\_ena*** bit in register *config49* to “0” to bypass the PLL circuitry.
2. ***pll\_sleep*** bit in register *config26* to “1” to put the PLL and VCO into sleep mode.

### 7.4.1.2 PLL Mode

In this mode the clock at the DACCLK input functions as a reference clock source to the on-chip PLL. The on-chip PLL will then multiply this reference clock to supply a higher frequency DAC cores clock. Figure 79 shows the block diagram of the PLL circuit, where N divider ratio ranges from 1 to 32, M divider ratio ranges from 1 to 256, and VCO prescaler divider from 2 to 18.



**Figure 79. PLL Block Diagram**

The DAC37J82/DAC38J82 PLL mode is selected by setting the following:

1. ***pll\_ena*** bit in register *config49* to “1” to route to the PLL and clock path.
2. ***pll\_sleep*** bit in register *config26* to “0” to enable the PLL and VCO.

The output frequency of the VCO covers two frequency spans: H-band (4.44–5.6GHz) and L-band (3.7–4.66GHz). When ***pll\_vcose1*** in register *config51* is “1”, the L-band is selected; when ***pll\_vcose1*** is “0”, the H-band is selected. At each band, the VCO range can be further adjusted by using the 6-bits ***pll\_vco*** in register *config51*. Figure 80 shows a typical relationship between the PLL VCO coarse tuning bits ***pll\_vco*** and the VCO center frequency. The corresponding equations for the H-band and L-band VCO are given in Equation 1 and Equation 2, respectively. Note that It is recommended to shift ***pll\_vco*** by +1 to guarantee the VCO operation at hot temp environment. In case of cold temp environment, shift by -1 on the variable ***pll\_vco*** is recommended.

$$\text{H-Band: VCO Frequency (MHz)} = 0.10998 \cdot \text{pll\_vco}^2 + 10.574 \cdot \text{pll\_vco} + 4446.3, \quad (1)$$

where ***pll\_vcose1*** = “0” and ***pll\_vcoitune*** = “11”.

$$\text{L-Band: VCO Frequency (MHz)} = 0.089703 \cdot \text{pll\_vco}^2 + 8.8312 \cdot \text{pll\_vco} + 3752.5, \quad (2)$$

where ***pll\_vcose1*** = “1” and ***pll\_vcoitune*** = “10”.



Device Functional Modes (continued)

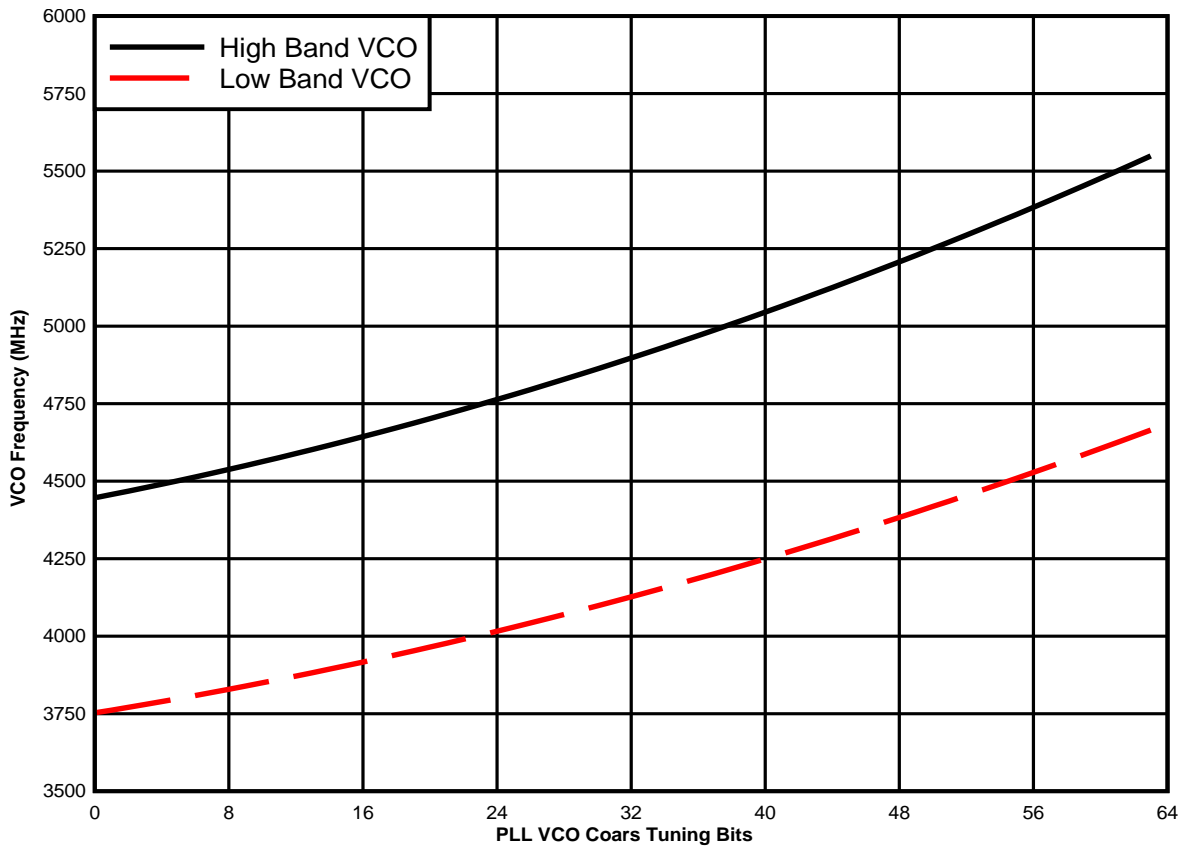


Figure 80. Typical PLL VCO Center Frequency vs Coarse Tuning Bits

Common wireless infrastructure frequencies are generated from this VCO frequency in conjunction with the pre-scaler setting *pll\_p* in register *config50* as shown in Table 28. When there are multiple valid VCO frequency and the pre-scaler settings to generate the same desired DACCLK frequency, higher pre-scaler divider ratio is recommended for better phase noise performance.

Table 28. VCO Operation

VCO FREQUENCY (MHz)	pll_vcose1	PRE-SCALE DIVIDER	DESIRED DACCLK (MHz)	pll_p(3:0)
4915.2	0	2	2457.6	0000
3932.16	1	2	1966.08	0000
4423.68	1	3	1474.56	0001
4915.2	0	4	1228.8	0010
4915.2	0	5	983.04	0011
5160.96	0	7	737.28	0101
4915.2	0	8	614.4	0110
4915.2	0	10	491.52	0111

The M divider is used to determine the phase-frequency-detector (PFD) and charge-pump (CP) frequency.

**Table 29. PFD and CP Operation**

DACCLK FREQUENCY (MHz)	M DIVIDER	PFD UPDATE RATE (MHz)	pll_m(7:0)
1474.56	12	122.88	00001011
1474.56	24	61.44	00010111
1474.56	48	30.72	00101111
1474.56	64	15.36	00111111

The N divider in the loop allows the PFD to operate at a lower frequency than the reference clock.

The overall divide ratio inside the loop is the product of the Pre-Scale and M dividers ( $P \cdot M$ ). The 5-bit *pll\_cp\_adj* is to set the charge pump current from 0 to 1.55mA with a step of 50µA. In nominal condition, if vco runs at 5GHz with P-ratio and M-ratio set as 2 and 4, the DACCLK frequency would be 2.5GHz and PFD frequency 625MHz. This needs 600µA charge pump current to stabilize the loop and gives the optimized phase noise performance. When  $P \cdot M$  ratio increases, the charge pump current needs to be increased accordingly to sustain enough phase margin for the loop. By tuning the charge pump current, a wide range of PM ratio can be supported with the internal loop filter. In very extreme cases when the  $P \cdot M$  ratio is huge (ex. PFD frequency of 10MHz, VCO frequency of 4GHz) and the loop cannot be stabilized even with the largest charge pump current, an external loop filter is required.

#### 7.4.2 PRBS Test Mode

The DAC37J82 and DAC38J82 support three types of PRBS sequences ( $2^7-1$ ,  $2^{23}-1$ , and  $2^{31}-1$ ) to verify the SerDes via SIF. To run the PRBS test on the DAC, users first need to setup the DAC for normal use, then make the following SPI writes:

1. *config74*, set bits 4:0 to 0x1E to disable JESD clock.
2. *config61*, set bits 14:12 to 0x2 to enable the 7-bit PRBS test pattern; or set bits 14:12 to 0x3 to enable the 23-bit PRBS test pattern; or set bits 14:12 to 0x4 to enable the 31-bit PRBS test pattern.
3. *config27*, set bits 11:8 to 0x3 to output PRBS testfail on ALARM pin.
4. *config27*, set bits 14:12 to the lane to be tested (0 through 7).
5. *config62*, make sure bits 12:11 are set to 0x0 to disable character alignment.

Users should monitor the ALARM pin to see the results of the test. If the test is failing, ALARM will be high (or toggling if marginal). If the test is passing, the ALARM will be low.

## 7.5 Register Map

Table 30. Register Map

Name	Address	Default	(MSB) Bit 15	Bit 14	Bit 13	Bit 12	Bit 11	Bit 10	Bit 9	Bit 8	Bit 7	Bit 6	Bit 5	Bit 4	Bit 3	Bit 2	Bit 1	(LSB) Bit 0		
config0	0x00	0x0218	qmc_offsetab_ena	qmc_offsetcd_ena	qmc_corrab_ena	qmc_corr_ena	interp(3:0)					alarm_zer_ostxenable_ena	outsum_ena	alarm_zeros_jesd_data_ena	alarm_out_ena	alarm_out_pol	pap_ena	inv_sinc_ab_ena	inv_sinc_cd_ena	
config1	0x01	0x0003	sfrac_ena_ab	sfrac_ena_cd	lfrac_ena_ab	lfrac_ena_cd	sfrac_sel_ab	sfrac_sel_cd	reserved	reserved	daca_compliment	dacb_compliment	dacc_compliment	dacd_compliment	reserved	reserved	reserved	reserved		
config2	0x02	0x2002	dac_bitwidth(1:0)		zer_invalid_data	shorttest_ena	reserved	reserved	reserved	reserved	sif4_ena	mixer_ena	mixer_gain	nco_ena	reserved	reserved	twos	sif_reset		
config3	0x03	0xF380	coarse_dac(3:0)				reserved					fif_error_zeros_data_ena	reserved					sif_tenable		
config4	0x04	0x00FF	alarms_mask(15:0)																	
config5	0x05	0xFFFF	alarms_mask(31:16)																	
config6	0x06	0xFFFF	alarms_mask(47:32)																	
config7	0x07	0x0000	memin_tempdata(7:0)								reserved				memin_lane_skew(4:0)					
config8	0x08	0x0000	reserved	reserved	reserved	reserved											qmc_offseta(12:0)			
config9	0x09	0x0000	reserved	reserved	reserved	reserved											qmc_offsetb(12:0)			
config10	0x0A	0x0000	reserved	reserved	reserved	reserved											qmc_offsetc(12:0)			
config11	0x0B	0x0000	reserved	reserved	reserved	reserved											qmc_offsetd(12:0)			
config12	0x0C	0x0400	reserved	reserved	reserved	reserved	reserved	reserved											qmc_gaina(10:0)	
config13	0x0D	0x0400	fs8	fs4	fs2	fsm4	reserved	reserved											qmc_gainb(10:0)	
config14	0x0E	0x0400	reserved	reserved	reserved	reserved	reserved	reserved											qmc_gainc(10:0)	
config15	0x0F	0x0400	output_delayab_reserved(1:0)		output_delaycd_reserved(1:0)		reserved	reserved											qmc_gaind(10:0)	
config16	0x10	0x0000	reserved	reserved	reserved	reserved	reserved											qmc_phaseab(11:0)		
config17	0x11	0x0000	reserved	reserved	reserved	reserved	reserved											qmc_phasecd(11:0)		
config18	0x12	0x0000	phaseoffsetab(15:0)																	
config19	0x13	0x0000	phaseoffsetcd(15:0)																	
config20	0x14	0x0000	phaseaddab(15:0)																	
config21	0x15	0x0000	phaseaddab(31:16)																	
config22	0x16	0x0000	phaseaddab(47:32)																	
config23	0x17	0x0000	phaseaddcd(15:0)																	
config24	0x18	0x0000	phaseaddcd(31:16)																	
config25	0x19	0x0000	phaseaddcd(47:32)																	
config26	0x1A	0x0020	reserved						reserved	vbgr_sleep	biasopamp_sleep	tsense_sleep	pll_sleep	clkrecv_sleep	daca_sleep	dacb_sleep	dacc_sleep	dacd_sleep		
config27	0x1B	0x0000	extref_ena	dtest_lane(2:0)			dtest(3:0)				reserved	reserved	atest(5:0)							
config28	0x1C	0x0000	reserved																	
config29	0x1D	0x0000	reserved																	
config30	0x1E	0x1111	syncsel_qmoffsetab(3:0)				syncsel_qmoffsetcd(3:0)				syncsel_qmcorrab(3:0)				syncsel_qmcorr_ena					
config31	0x1F	0x1140	syncsel_mixerab(3:0)				syncsel_mixercd(3:0)				syncsel_nco(3:0)				reserved	sif_sync	reserved			

**DAC37J82, DAC38J82**

ZHCSCG7B – JANUARY 2014 – REVISED MAY 2014

[www.ti.com.cn](http://www.ti.com.cn)
**Table 30. Register Map (continued)**

Name	Address	Default	(MSB) Bit 15	Bit 14	Bit 13	Bit 12	Bit 11	Bit 10	Bit 9	Bit 8	Bit 7	Bit 6	Bit 5	Bit 4	Bit 3	Bit 2	Bit 1	(LSB) Bit 0
config32	0x20	0x0000	syncsel_dither(3:0)			reserved			syncsel_pap(3:0)			syncsel_fir5a(3:0)						
config33	0x21	0x0000	reserved															
config34	0x22	0x1B1B	patha_in_sel(1:0)		pathb_in_sel(1:0)		pathc_in_sel(1:0)		pathd_in_sel(1:0)		patha_out_sel(1:0)		pathb_out_sel(1:0)		pathc_out_sel(1:0)		pathd_out_sel(1:0)	
config35	0x23	0xFFFF	sleep_cntl(15:0)															
config36	0x24	0x0000	reserved						cdrvser_sysref_mode(2:0)			reserved		reserved				
config37	0x25	0x0000	clkjesd_div(2:0)			reserved			reserved			reserved			reserved		reserved	
config38	0x26		dither_ena(3:0)			dither_mixer_ena(3:0)			dither_sra_sel(3:0)			reserved		reserved	dither_zero			
config39	0x27	0x0000	reserved(15:0)															
config40	0x28	0x0000	reserved(15:0)															
config41	0x29	0x0000	reserved(15:0)															
config42	0x2A	0x0000	reserved(15:0)															
config43	0x2B	0x0000	reserved(15:0)															
config44	0x2C	0x0000	reserved(15:0)															
config45	0x2D	0x0000	reserved	reserved											pap_dlylen_sel	pap_gain(2:0)		
config46	0x2E	0xFFFF	pap_vth(15:0)															
config47	0x2F	0x0004	reserved	titest_dieid_read_ena	reserved	reserved									reserved	reserved	sifdac_ena	
config48	0x30	0x0000	sifdac(15:0)															
config49	0x31	0x0000	lockdet_adj(2:0)			pll_reset	pll_ndivsync_ena	pll_ena	pll_cp(1:0)		pll_n(4:0)				memin_pll_lfvolt(2:0)			
config50	0x32	0x0000	pll_m(7:0)							pll_p(3:0)			reserved					
config51	0x33	0x0100	pll_vcose	pll_vco(5:0)					pll_vcoitune(1:0)		pll_cp_adj(4:0)			reserved				
config52	0x34	0x0000	syncb_lvds_lpwrb	syncb_lvds_lpwra	syncb_lvds_lpsel	syncb_lvds_effuse_sel	reserved		reserved	lvds_sleep	lvds_sub_ena	reserved(6:0)						
config53	0x35	0x0000	reserved			reserved			reserved			reserved						
config54	0x36	0x0000	reserved															
config55	0x37	0x0000	reserved															
config56	0x38	0x0000	reserved															
config57	0x39	0x0000	reserved															
config58	0x3A	0x0000	reserved															
config59	0x3B	0x0000	serdes_clk_sel	serdes_refclk_div(3:0)				reserved							reserved			
config60	0x3C	0x0000	rw_cfgpll(15:0)															
config61	0x3D	0x0000	reserved	rw_cfggrx0(14:0)														
config62	0x3E	0x0000	rw_cfggrx0(15:0)															
config63	0x3F	0x0000	reserved								INVPAIR(7:0)							
config64	0x40	0x0000	reserved															
config65	0x41	0x0000	errorcnt_link0(15:0)															
config66	0x42	0x0000	errorcnt_link1(15:0)															

Table 30. Register Map (continued)

Name	Address	Default	(MSB) Bit 15	Bit 14	Bit 13	Bit 12	Bit 11	Bit 10	Bit 9	Bit 8	Bit 7	Bit 6	Bit 5	Bit 4	Bit 3	Bit 2	Bit 1	(LSB) Bit 0				
config67	0x43	0x0000	errorcnt_link2(15:0)																			
config68	0x44	0x0000	errorcnt_link3(15:0)																			
config69	0x45	0x0000	reserved																			
config70	0x46	0x0044	lid0(4:0)				lid1(4:0)				lid2(4:0)				reserved							
config71	0x47	0x190A	lid3(4:0)				lid4(4:0)				lid5(4:0)				reserved							
config72	0x48	0x31C3	lid6(4:0)				lid7(4:0)				reserved		subclassv(2:0)				jesdv					
config73	0x49	0x0000	link_assign(15:0)																			
config74	0x4A	0x001E	lane_ena(7:0)						jesd_test_seq(1:0)		dual		init_state(3:0)				jesd_reset_n					
config75	0x4B	0x0000	reserved				rbd_m1(4:0)				f_m1(7:0)											
config76	0x4C	0x0000	reserved				k_m1(4:0)				reserved		reserved		reserved		l_m1(4:0)					
config77	0x4D	0x0300	m_m1(7:0)						reserved		s_m1(4:0)											
config78	0x4E	0x0F0F	reserved				nprime_m1(4:0)				reserved		hd		scr		n_m1(4:0)					
config79	0x4F	0x1CC1	match_data(7:0)						match_specific		match_ctrl		no_lane_sync		reserved				jesd_commaalign_ena			
config80	0x50	0x0000	adjcnt_link0(3:0)				adjdir_link0		bid_link0(3:0)				cf_link0(4:0)				cs_link0(1:0)					
config81	0x51	0x00FF	did_link0(7:0)								sync_request_ena_link0(7:0)											
config82	0x52	0x00FF	reserved						disable_err_report_link0		phadj_link0		error_ena_link0(7:0)									
config83	0x53	0x0000	adjcnt_link1(3:0)				adjdir_link1		bid_link1(3:0)				cf_link1(4:0)				cs_link1(1:0)					
config84	0x54	0x00FF	did_link1(7:0)								sync_request_ena_link1(7:0)											
config85	0x55	0x00FF	reserved						disable_err_report_link1		phadj_link1		error_ena_link1(7:0)									
config86	0x56	0x0000	adjcnt_link2(3:0)				adjdir_link2		bid_link2(3:0)				cf_link2(4:0)				cs_link2(1:0)					
config87	0x57	0x00FF	did_link2(7:0)								sync_request_ena_link2(7:0)											
config88	0x58	0x00FF	reserved						disable_err_report_link2		phadj_link2		error_ena_link2(7:0)									
config89	0x59	0x0000	adjcnt_link3(3:0)				adjdir_link3		bid_link3(3:0)				cf_link3(4:0)				cs_link3(1:0)					
config90	0x5A	0x00FF	did_link3(7:0)								sync_request_ena_link3(7:0)											
config91	0x5B	0x00FF	reserved						disable_err_report_link3		phadj_link3		error_ena_link3(7:0)									
config92	0x5C	0x1111	err_cnt_clr_link3		sysref_mode_link3(2:0)				err_cnt_clr_link2		sysref_mode_link2(2:0)				err_cnt_clr_link1		sysref_mode_link1(2:0)		err_cnt_clr_link0		sysref_mode_link0(2:0)	
config93	0x5D	0x0000	reserved																			
config94	0x5E	0x0000	res1(7:0)								res2(7:0)											
config95	0x60	0x0123	reserved		octetpath_sel(0)(2:0)				reserved		octetpath_sel(1)(2:0)				reserved		octetpath_sel(2)(2:0)		reserved		octetpath_sel(3)(2:0)	
config96	0x61	0x0456	reserved		octetpath_sel(4)(2:0)				reserved		octetpath_sel(5)(2:0)				reserved		octetpath_sel(6)(2:0)		reserved		octetpath_sel(7)(2:0)	

**Table 30. Register Map (continued)**

Name	Address	Default	(MSB) Bit 15	Bit 14	Bit 13	Bit 12	Bit 11	Bit 10	Bit 9	Bit 8	Bit 7	Bit 6	Bit 5	Bit 4	Bit 3	Bit 2	Bit 1	(LSB) Bit 0
config97	0x62	0x000F	syncn_pol	reserved			syncncd_sel(3:0)			syncnab_sel(3:0)			syncn_sel(3:0)					
config98	0x63	0x0000	reserved	reserved			reserved			reserved								
config98	0x64	0x0000	reserved	reserved			reserved			reserved			Reserved					
config100	0x65	0x0000				alarm_l_error(0)(7:0)						reserved			alarm_fifo_flags(0)(3:0)			
config101	0x66	0x0000				alarm_l_error(1)(7:0)						reserved			alarm_fifo_flags(1)(3:0)			
config102	0x67	0x0000				alarm_l_error(2)(7:0)						reserved			alarm_fifo_flags(2)(3:0)			
config103	0x68	0x0000				alarm_l_error(3)(7:0)						reserved			alarm_fifo_flags(3)(3:0)			
config104	0x69	0x0000				alarm_l_error(4)(7:0)						reserved			alarm_fifo_flags(4)(3:0)			
config105	0x6A	0x0000				alarm_l_error(5)(7:0)						reserved			alarm_fifo_flags(5)(3:0)			
config106	0x6B	0x0000				alarm_l_error(6)(7:0)						reserved			alarm_fifo_flags(6)(3:0)			
config107	0x6C	0x0000				alarm_l_error(7)(7:0)						reserved			alarm_fifo_flags(7)(3:0)			
config108	0x6D	0x0000	alarm_sysref_err(3:0)						alarm_pap(3:0)			reserved			alarm_rw0_pll	alarm_rw1_pll	reserved	alarm_from_pll
config109	0x6E	0x00xx				alarm_from_shorttest(7:0)						memin_rw_losdct(7:0)						
config110	0x6F	0x0000	sfrac_coef0_ab(1;0)	sfrac_coef1_ab(4;0)						sfrac_coef2_ab(7;0)							Reserved	
config111	0x70	0x0000	reserved						sfrac_coef3_ab(9;0)									
config112	0x71	0x0000	sfrac_coef4_ab(15;0)															
config113	0x72	0x0000	sfrac_coef4_ab(18:16)	reserved						sfrac_coef5_ab(9;0)								
config114	0x73	0x0000	reserved						sfrac_coef6_ab(8;0)									
config115	0x74	0x0000	sfrac_coef7_ab(6;0)						sfrac_coef8_ab(4;0)			sfrac_coef9_ab(1;0)			Reserved			
config116	0x75	0x0000	sfrac_invgain_ab(15;0)															
config117	0x76	0x0000	sfrac_invgain_ab(19:16)			reserved			lfras_coef_sel_a(2;0)			lfras_coef_sel_b(2;0)						
config118	0x77	0x0000	sfrac_coef0_cd(1;0)	sfrac_coef1_cd(4;0)						sfrac_coef2_cd(7;0)							Reserved	
config119	0x78	0x0000	reserved						sfrac_coef3_cd(9;0)									
config120	0x79	0x0000	sfrac_coef4_cd(15;0)															
config121	0x7A	0x0000	sfrac_coef4_cd(18:16)	reserved						sfrac_coef5_cd(9;0)								
config122	0x7B	0x0000	reserved						sfrac_coef6_cd(8;0)									
config123	0x7C	0x0000	sfrac_coef7_cd(6;0)						sfrac_coef8_cd(4;0)			sfrac_coef9_cd(1;0)			Reserved			
config124	0x7D	0x0000	sfrac_invgain_cd(15;0)															
config125	0x7E	0x0000	sfrac_invgain_cd(19:16)			reserved			lfras_coef_sel_c(2;0)			lfras_coef_sel_d(2;0)						
config126	0x7F	0x0000	reserved			reserved			reserved			reserved						
config127	0x80	0x0000	memin_efc_autoload_done	memin_efc_error(4;0)			reserved			reserved			vendorid(1;0)		versionid(2;0)			

### 7.5.1 Register Descriptions

**Table 31. Register Name: config0 – Address: 0x00, Default: 0x0218**

Register Name	Addr (Hex)	Bit	Name	Function	Default Value
config0	0x0	15	qmc_offsetab_ena	Enable the offset function for the AB data path when asserted.	0
		14	qmc_offsetcd_ena	Enable the offset function for the CD data path when asserted.	0
		13	qmc_corrab_ena	Enable the Quadrature Modulator Correction (QMC) function for the AB data path when asserted.	0
		12	qmc_corr_ena	Enable the QMC function for the CD data path when asserted.	0
		11:08	interp	Determines the interpolation amount. 0000: 1x 0001: 2x 0010: 4x 0100: 8x 1000: 16x	0010
		7	alarm_zeros_txenable_ena	When asserted any alarm that isn't masked will mid-level the DAC output.	0
		6	outsum_ena	Turns on the summing of the A+C and B+D data paths.	0
		5	alarm_zeros_jesd_data_ena	When asserted any alarm that isn't masked will zero the data coming out of the JESD block.	0
		4	alarm_out_ena	When asserted the pin ALARM becomes an output instead of a tri-stated pin.	1
		3	alarm_out_pol	This bit changes the polarity of the ALARM signal. (0=negative logic, 1=positive logic)	1
		2	pap_ena	Turns on the Power Amp Protection (PAP) logic.	0
		1	inv_sinc_ab_ena	Turns on the inverse sinc filter for the AB path when programmed to '1'.	0
		0	inv_sinc_cd_ena	Turns on the inverse sinc filter for the CD path when programmed to '1'.	0

**Table 32. Register Name: config1 – Address: 0x01, Default: 0x0003**

Register Name	Addr (Hex)	Bit	Name	Function	Default Value
config1	0x1	15	sfrac_ena_ab	Turn on the small fractional delay filter for the AB data path.	0
		14	sfrac_ena_cd	Turn on the small fractional delay filter for the CD data path.	0
		13	lfrac_ena_ab	Turn on the large fractional delay filter for the AB data path.	0
		12	lfrac_ena_cd	Turn on the large fractional delay filter for the CD data path.	0
		11	sfrac_sel_ab	Select which data path is delay through the filter and which is delayed through the matched delay line. 0 : Data path B goes through filter 1 : Data path A goes through filter	0
		10	sfrac_sel_cd	Select which data path is delay through the filter and which is delayed through the matched delay line. 0 : Data path D goes through filter 1 : Data path C goes through filter	0
		9	reserved	Reserved	0
		8	reserved	Reserved	0
		7	daca_compliment	When asserted the output to the DACA is complimented. This allows the user of the chip to effectively change the + and – designations of the IOUTA pins.	0
		6	dacb_compliment	When asserted the output to the DACB is complimented. This allows the user of the chip to effectively change the + and – designations of the IOUTB pins.	0
		5	dacc_compliment	When asserted the output to the DACC is complimented. This allows the user of the chip to effectively change the + and – designations of the IOUTC pins.	0
		4	dacd_compliment	When asserted the output to the DACD is complimented. This allows the user of the chip to effectively change the + and – designations of the IOUTD pins.	0
		3	reserved	Reserved	0
		2	reserved	Reserved	0
1	reserved	Reserved	1		
0	reserved	Reserved	1		



**Table 33. Register Name: config2 – Address: 0x02, Default: 0x2002**

Register Name	Addr (Hex)	Bit	Name	Function	Default Value
config2	0x2	10:14	dac_bitwidth	Determines the bit width of the DAC. 00 : 16 bits 01 : 14 bits 10 : 16 bits 11 : 12 bits	00
		13	zero_invalid_data	Zero the data from the JESD block when the link is not established.	1
		12	shorttest_ena	Turns on the short test pattern of the JESD interface.	0
		11	reserved	Reserved	0
		10	reserved	Reserved	0
		9	reserved	Reserved	0
		8	reserved	Reserved	0
		7	sif4_ena	When asserted the SIF interface becomes a 4 pin interface. This bit has a lower priority than the <b>dieid_ena</b> bit.	0
		6	mixer_ena	When set high, the mixer block is turned on.	0
		5	mixer_gain	Add 6dB of gain to the mixer output when asserted.	0
		4	nco_ena	When set high, the full NCO block is turned on. This is not necessary for the fs/2, fs/4, -fs/4 and fs/8 modes.	0
		3	reserved	Reserved	0
		2	reserved	Reserved	0
		1	twos	When asserted, this bit tells the chip to presume that 2's complement data is arriving at the input. Otherwise offset binary is presumed.	1
0	sif_reset	A transition from 0->1 causes a reset of the SIF registers. This bit is self clearing.	0		

**Table 34. Register Name: config3 – Address: 0x03, Default: 0xF380**

Register Name	Addr (Hex)	Bit	Name	Function	Default Value
config3	0x3	15:12	coarse_dac	Scales the output current in 16 equal steps. $\frac{V_{refIO}}{R_{bias}} \times 4 \times (\text{mem\_coarse\_daca} + 1)$	1111
		11:8	reserved	Reserved	0011
		7	fifo_error_zeros_data_ena	When asserted SerDes FIFO errors zero the data out of the JESD block.	1
		6:1	reserved	Reserved	000000
		0	sif_txenable	When asserted the internal value of TXENABLE is '1'.	0

**Table 35. Register Name: config4 – Address: 0x04, Default: 0x00FF**

Register Name	Addr (Hex)	Bit	Name	Function	Default Value
config4	0x4	15:0	alarms_mask(15:0)	Each bit is used to mask an alarm. Assertion masks the alarm: bit15 = mask lane7 lane errors bit14 = mask lane6 lane errors bit13 = mask lane5 lane errors bit12 = mask lane4 lane errors bit11 = mask lane3 lane errors bit10 = mask lane2 lane errors bit9 = mask lane1 lane errors bit8 = mask lane0 lane errors bit7 = mask lane7 FIFO flags bit6 = mask lane6 FIFO flags bit5 = mask lane5 FIFO flags bit4 = mask lane4 FIFO flags bit3 = mask lane3 FIFO flags bit2 = mask lane2 FIFO flags bit1 = mask lane1 FIFO flags bit0 = mask lane0 FIFO flags	0x00FF

**Table 36. Register Name: config5 – Address: 0x05, Default: 0xFFFF**

Register Name	Addr (Hex)	Bit	Name	Function	Default Value
config5	0x5	15:0	alarms_mask(31:16)	Each bit is used to mask an alarm. Assertion masks the alarm: bit15 = mask SYSREF errors on link3 bit14 = mask SYSREF errors on link2 bit13 = mask SYSREF errors on link1 bit12 = mask SYSREF errors on link0 bit11 = mask alarm from PAP A block bit10 = mask alarm from PAP B block bit9 = mask alarm from PAP C block bit8 = mask alarm from PAP D block bit7 = reserved bit6 = reserved bit5 = reserved bit4 = reserved bit3 = mask alarm from SerDes block 0 PLL lock bit2 = mask alarm from SerDes block 1 PLL lock bit1 = mask SYSREF setup/hold measurement alarm bit0 = mask DAC PLL lock alarm	0xFFFF

**Table 37. Register Name: config6 – Address: 0x06, Default: 0xFFFF**

Register Name	Addr (Hex)	Bit	Name	Function	Default Value
config6	0x6	15:0	alarms_mask(47:32)	Each bit is used to mask an alarm. Assertion masks the alarm: bit15 = mask alarm from lane7 short test bit14 = mask alarm from lane6 short test bit13 = mask alarm from lane5 short test bit12 = mask alarm from lane4 short test bit11 = mask alarm from lane3 short test bit10 = mask alarm from lane2 short test bit9 = mask alarm from lane1 short test bit8 = mask alarm from lane0 short test bit7 = mask alarm from lane7 loss of signal detect bit6 = mask alarm from lane6 loss of signal detect bit5 = mask alarm from lane5 loss of signal detect bit4 = mask alarm from lane4 loss of signal detect bit3 = mask alarm from lane3 loss of signal detect bit2 = mask alarm from lane2 loss of signal detect bit1 = mask alarm from lane1 loss of signal detect bit0 = mask alarm from lane0 loss of signal detect	0xFFFF

**Table 38. Register Name: config7 – Address: 0x07, Default: 0x0000**

Register Name	Addr (Hex)	Bit	Name	Function	Default Value
config7 No RESET Value	0x7	15:8	memin_tempdata	This is the output from the chip temperature sensor. NOTE: when reading these bits the SIF interface must be extremely slow, 1MHz range.	0x00
		7:5	reserved	Reserved	000
		4:0	memin_lane_skew	Measure of the lane skew for link0 only. Updated when the RBD is released and measured in terms of JESD clock. <b>NOTE: these bits are READ_ONLY</b>	0000

**Table 39. Register Name: config8 – Address: 0x08, Default: 0x0000**

Register Name	Addr (Hex)	Bit	Name	Function	Default Value
config8 AUTO SYNC	0x8	15	reserved	Reserved	0
		14	reserved	Reserved	0
		13	reserved	Reserved	0
		12:0	qmc_offseta	The DAC A offset correction. The offset is measured in DAC LSBs. <b>NOTE: Writing this register causes an auto-sync to be generated in the QMC OFFSET block.</b>	0x0000

**Table 40. Register Name: config9 – Address: 0x09, Default: 0x0000**

Register Name	Addr (Hex)	Bit	Name	Function	Default Value
config9	0x9	15:13	reserved	Reserved	000
		12:0	qmc_offsetb	The DAC B offset correction. The offset is measured in DAC LSBs.	0x0000

**Table 41. Register Name: config10 – Address: 0x0A, Default: 0x0000**

Register Name	Addr (Hex)	Bit	Name	Function	Default Value
config10 AUTO SYNC	0xA	15:13	reserved	Reserved	000
		12:0	qmc_offsetc	The DAC C offset correction. The offset is measured in DAC LSBs. <b>NOTE: Writing this register causes an auto-sync to be generated in the QMC OFFSET block.</b>	0x0000

**Table 42. Register Name: config11 – Address: 0x0B, Default: 0x0000**

Register Name	Addr (Hex)	Bit	Name	Function	Default Value
config11	0xB	15:13	reserved	Reserved	000
		12:0	qmc_offsetd	The DAC D offset correction. The offset is measured in DAC LSBs	0x0000

**Table 43. Register Name: config12 – Address: 0xC, Default: 0x0400**

Register Name	Addr (Hex)	Bit	Name	Function	Default Value
config12	0xC	15	reserved	Reserved	0
		14	reserved	Reserved	0
		13	reserved	Reserved	0
		12	reserved	Reserved	0
		11	reserved	Reserved	0
		10:0	gmc_gaina	The quadrature correction gain A for DACAB path. The decimal point for the multiplication is just left of bit9. This word is treated as unsigned so the range is 0 to 1.9990. LSB=0.0009766	0x400

**Table 44. Register Name: config13 – Address: 0xD, Default: 0x0400**

Register Name	Addr (Hex)	Bit	Name	Function	Default Value
config13	0xD	15	fs8	These bits turn on the different coarse mixing options. Combining the different options together can result in every possible $n \cdot Fs/8$ [ $n=0 \rightarrow 7$ ]. Below is the valid programming table: cmix=(fs8, fs4, fs2, fsm4) 0000 : no mixing 0001 : -fs/4 0010 : fs/2 0100 : fs/4 1000 : fs/8 1100 : 3fs/8 1010 : 5fs/8 1110 : 7fs/8	0
		14	fs4		0
		13	fs2		0
		12	fsm4		0
		11	reserved	Reserved	0
		10:0	qmc_gainb	The quadrature correction gain B for DAC AB path. The decimal point for the multiplication is just left of bit9. This word is treated as unsigned so the range is 0 to 1.9990. LSB=0.0009766.	0x400

**Table 45. Register Name: config14 – Address: 0x0E, Default: 0x0400**

Register Name	Addr (Hex)	Bit	Name	Function	Default Value
config14	0xE	15	reserved	Reserved	0
		14	reserved	Reserved	0
		13	reserved	Reserved	0
		12	reserved	Reserved	0
		11	reserved	Reserved	0
		10:0	gmc_gainc	The quadrature correction gain A for DACCD path. The decimal point for the multiplication is just left of bit9. This word is treated as unsigned so the range is 0 to 1.9990. LSB=0.0009766.	0x400

**Table 46. Register Name: config15 – Address: 0x0F, Default: 0x0400**

Register Name	Addr (Hex)	Bit	Name	Function	Default Value
config15	0xF	15:14	output_delayab	Delays the output to the DACs from 0 to 3 DAC clock cycles.	00
		13:12	output_delaycd	Delays the output to the DACs from 0 to 3 DAC clock cycles.	00
		11	reserved	Reserved	0
		10:0	qmc_gainb	The quadrature correction gain B for DACCD path. The decimal point for the multiplication is just left of bit9. This word is treated as unsigned so the range is 0 to 1.9990. LSB=0.0009766.	0x400

**Table 47. Register Name: config16 – Address: 0x10, Default: 0x0000**

Register Name	Addr (Hex)	Bit	Name	Function	Default Value
config16 AUTO SYNC	0x10	15	reserved	Reserved	0
		14	reserved	Reserved	0
		13	reserved	Reserved	0
		12	reserved	Reserved	0
		11:0	qmc_phaseab	The QMC correction phase term for the DACAB path. The range is –0.5 to 0.49975. Programming “100000000000” = –0.5. Programming “011111111111” = 0.49975.	0x000

**Table 48. Register Name: config17 – Address: 0x11, Default: 0x0000**

Register Name	Addr (Hex)	Bit	Name	Function	Default Value
config17 AUTO SYNC	0x11	15	reserved	Reserved	0
		14	reserved	Reserved	0
		13	reserved	Reserved	0
		12	reserved	Reserved	0
		11:0	qmc_phasecd	The QMC correction phase term for the DACAD path. The range is –0.5 to 0.49975. Programming “100000000000” = –0.5. Programming “011111111111” = 0.49975.	0x000

**Table 49. Register Name: config18 – Address: 0x12, Default: 0x0000**

Register Name	Addr (Hex)	Bit	Name	Function	Default Value
config18 AUTO SYNC	0x12	15:0	phaseoffsetab	Phase offset for NCO in DACAB path	0x0000

**Table 50. Register Name: config19 – Address: 0x13, Default: 0x0000**

Register Name	Addr (Hex)	Bit	Name	Function	Default Value
config19 AUTO SYNC	0x13	15:0	phaseoffsetcd	Phase offset for NCO in DACAB path	0x0000

**Table 51. Register Name: config20 – Address: 0x14, Default: 0x0000**

Register Name	Addr (Hex)	Bit	Name	Function	Default Value
config20	0x14	15:0	phaseaddab	Lower 16 bits of NCO Frequency adjust word for DACAB path.	0x0000

**Table 52. Register Name: config21 – Address: 0x15, Default: 0x0000**

Register Name	Addr (Hex)	Bit	Name	Function	Default Value
config21	0x15	15:0	phaseaddab	Middle 16 bits of NCO Frequency adjust word for DACAB path.	0x0000

**Table 53. Register Name: config22 – Address: 0x16, Default: 0x0000**

Register Name	Addr (Hex)	Bit	Name	Function	Default Value
config22	0x16	15:0	phaseaddab	Upper 16 bits of NCO Frequency adjust word for DACAB path.	0x0000

**Table 54. Register Name: config23 – Address: 0x17, Default: 0x0000**

Register Name	Addr (Hex)	Bit	Name	Function	Default Value
config23	0x17	15:0	phaseaddcd	Lower 16 bits of NCO Frequency adjust word for DACCD path.	0x0000

**Table 55. Register Name: config24 – Address: 0x18, Default: 0x0000**

Register Name	Addr (Hex)	Bit	Name	Function	Default Value
config24	0x18	15:0	phaseaddcd	Middle 16 bits of NCO Frequency adjust word for DACCD path.	0x0000

**Table 56. Register Name: config25 – Address: 0x19, Default: 0x0000**

Register Name	Addr (Hex)	Bit	Name	Function	Default Value
config25	0x19	15:0	phaseaddcd	Upper 16 bits of NCO Frequency adjust word for DACCD path.	0x0000

**Table 57. Register Name: config26 – Address: 0x1A, Default: 0x0020**

Register Name	Addr (Hex)	Bit	Name	Function	Default Value
config26	0x1A	15:10	reserved	Reserved	000000
		9	reserved	Reserved	0
		8	vbgr_sleep	Turns off the Bandgap over internal R bias current generator bias	0
		7	biasopamp_sleep	Turns off the bias OP amp when high.	0
		6	tsense_sleep	Turns off the temperature sensor when asserted.	0
		5	pll_sleep	Puts the DAC PLL into sleep mode when asserted.	1 FUSE controlled
		4	clkrecv_sleep	When asserted the clock input receiver gets put into sleep mode. This also affects the SYSREF receiver as well.	0
		3	daca_sleep	When asserted DACA is put into sleep mode	0
		2	dacb_sleep	When asserted DACB is put into sleep mode	0
		1	dacc_sleep	When asserted DACC is put into sleep mode	0
0	dacd_sleep	When asserted DACD is put into sleep mode	0		

**Table 58. Register Name: config27 – Address: 0x1B, Default: 0x0000**

Register Name	Addr (Hex)	Bit	Name	Function	Default Value
config27	0x1B	15	extref_ena	Allows the chip to use an external reference or the internal reference. (0=internal, 1=external)	0
		14:12	dtest_lane	Selects the lane to output the test signal. 0=lane0, 7=lane7	000
		11:8	dtest	Allows digital test signals to come out the ALARM pin. 0000 : Test disabled, normal ALARM pin function 0001 : SERDES Block0 PLL clock/80 0010 : SERDES Block1 PLL clock/80 0011 : TESTFAIL (lane selected by dtest_lane) 0100 : SYNC(lane selected by dtest_lane) 0101 : OCIP (lane selected by dtest_lane) 0110 : EQUUNDER (lane selected by dtest_lane) 0111 : EQOVER (lane selected by dtest_lane) 1000 – 1111 : not used	0000
		7	reserved	Reserved	0
		6	reserved	Reserved	0
		5:0	atest	Selects measurement of various internal signals at the ATEST pin. 0=off 000001 : DAC PLL VSSA (0V) 000010 : DAC PLL VDDCLK09 at DACCLK receiver and ndivider (0.9V) 000011 : DAC PLL 100uA bias current measurement into 0V 000100 : DAC PLL 100uA vbias at VCO (~-0.8V nmos diode) 000101 : DAC PLL VDDCLK09 at prescaler and mdivider (0.9V) 000110 : DAC PLL VSSA (0V) 000111 : DAC PLL VDDAPLL18 (1.8V) 001000 : DAC PLL loop filter voltage (0 to 1V, ~-0.5V when locked) 001001 : DACA VDDAREF18 (1.8V) 001010 : DACA VDDCLK09 (0.9) 001011 : DACA VDDDAC09 (0.9) 001100 : DACA VSSA (0V) 001101 : DACA VSSESD (0V) 001110 : DACA VSSA (0V) 001111 : DACA main current source PMOS cascode bias (1.65V) 010000 : DACA output switch cascode bias (0.4V) 010001 : DACB VDDAREF18 (1.8V) 010010 : DACB VDDCLK09 (0.9) 010011 : DACB VDDDAC09 (0.9) 010100 : DACB VSSA (0V) 010101 : DACB VSSESD (0V) 010110 : DACB VSSA (0V) 010111 : DACB main current source PMOS cascode bias (1.65V) 011000 : DACB output switch cascode bias (0.4V) 011001 : DACC VDDAREF18 (1.8V) 011010 : DACC VDDCLK09 (0.9) 011011 : DACC VDDDAC09 (0.9) 011100 : DACC VSSA (0V) 011101 : DACC VSSESD (0V) 011110 : DACC VSSA (0V) 011111 : DACC main current source PMOS cascode bias (1.65V)	000000

**Table 58. Register Name: config27 – Address: 0x1B, Default: 0x0000 (continued)**

Register Name	Addr (Hex)	Bit	Name	Function	Default Value
config27 (continued)	0x1B	5:0	atest	100000 : DACC output switch cascode bias (0.4V) 100001 : DACD VDDAREF18 (1.8V) 100010 : DACD VDDCLK09 (0.9) 100011 : DACD VDDDAC09 (0.9) 100100 : DACD VSSA (0V) 100101 : DACD VSSESD (0V) 100110 : DACD VSSA (0V) 100111 : DACD main current source PMOS cascode bias (1.65V) 101000 : DACD output switch cascode bias (0.4V) 101001 : Temp Sensor VSSA (0V) 101010 : Temp Sensor amplifier output (0 to 1.8V) 101011 : Temp Sensor reference output (~0.6V, can be trimmed) 101100 : Temp Sensor comparator output (0 to 1.8V) 101101 : Temp Sensor 64uA bias voltage (~0.8V nmos diode) 101110 : BIASGEN 100uA bias measured to 0V (to be trimmed) 101111 : Temp Sensor VDDDAC09 (0.9V) 110000 : Temp Sensor VDDAREF18 (1.8V) 110001 : DAC bias current measured into 1.8V. scales with coarse DAC setting (7.3µA to 117µA) 110010 : Bangap PTAT current measured into 0V (~20µA) 110011 : CoarseDAC PMOS current source gate (-1V) 110100 : RBIAS (0.9V) 110101 : EXTIO (0.9V) 110110 : Bandgap PMOS cascode gate (0.7V) 110111 : Bandgap startup circuit output (-0V when BG started) 111000 : Bandgap output (0.9V, can be trimmed) 111001 : SYNCB LVDS buffer reference voltage (1.2V), must set syncb_lvds_efuse_sel to measure. 111010 : VSS in digital core MET1 (0V) 111011 : VSS in digital core MET1 (0V) 111100 : VSS near bump (0V) 111101 : VDDDIG09 in digital core MET1 (0.9V) 111110 : VDDDIG09 in digital core MET1 (0.9V)	000000

**Table 59. Register Name: config28 – Address: 0x1C, Default: 0x0000**

Register Name	Addr (Hex)	Bit	Name	Function	Default Value
config28	0x1C	15:8	reserved	reserved	0x00
		7:0	reserved	reserved	0x00

**Table 60. Register Name: config29 – Address: 0x1D, Default: 0x0000**

Register Name	Addr (Hex)	Bit	Name	Function	Default Value
config29	0x1D	15:8	reserved	reserved	0x00
		7:0	reserved	reserved	0x00



**Table 61. Register Name: config30 – Address: 0x1E, Default: 0x1111**

Register Name	Addr (Hex)	Bit	Name	Function	Default Value
config30	0x1E	15:12	syncsel_qmoffsetab	Select the sync for the QMCOffsetAB block. A '1' in the selected bit place allows the selected sync to pass to the block. bit0 = auto-sync from SIF register write bit1 = sysref bit2 = sync_out from JESD bit3 = sif_sync	0x1
		11:8	syncsel_qmoffsetcd	Select the sync for the QMCOffsetCD block. A '1' in the selected bit place allows the selected sync to pass to the block. bit0 = auto-sync from SIF register write bit1 = sysref bit2 = sync_out from JESD bit3 = sif_sync	0x1
		7:4	syncsel_qmcorrab	Select the sync for the QMCCorrAB block. A '1' in the selected bit place allows the selected sync to pass to the block. bit0 = auto-sync from SIF register write bit1 = sysref bit2 = sync_out from JESD bit3 = sif_sync	0x1
		3:0	syncsel_qmcorrcd	Select the sync for the QMCCorrCD block. A '1' in the selected bit place allows the selected sync to pass to the block. bit0 = auto-sync from SIF register write bit1 = sysref bit2 = sync_out from JESD bit3 = sif_sync	0x1

**Table 62. Register Name: config31 – Address: 0x1F, Default: 0x1111**

Register Name	Addr (Hex)	Bit	Name	Function	Default Value
config31	0x1F	15:12	syncsel_mixerab	Select the sync for the mixerAB block. A '1' in the selected bit place allows the selected sync to pass to the block. bit0 = auto-sync from SIF register write bit1 = sysref bit2 = sync_out from JESD bit3 = sif_sync	0x1
		11:8	syncsel_mixercd	Select the sync for the mixerCD block. A '1' in the selected bit place allows the selected sync to pass to the block. bit0 = auto-sync from SIF register write bit1 = sysref bit2 = sync_out from JESD bit3 = sif_sync	0x1
		7:4	syncsel_nco	Select the sync for the NCO accumulators. A '1' in the selected bit place allows the selected sync to pass to the block. bit0 = '0' bit1 = sysref bit2 = sync_out from JESD bit3 = sif_sync	0x4
		3:2	reserved	Reserved	00
		1	sif_sync	This is the SIF SYNC signal.	0
		0	reserved	Reserved	0

**Table 63. Register Name: config32 – Address: 0x20, Default: 0x0000**

Register Name	Addr (Hex)	Bit	Name	Function	Default Value
config32	0x20	15:12	syncsel_dither	Select the sync for the Dithering block. bit0 = '0' bit1 = sysref bit2 = sync_out from JESD bit3 = sif_sync	0x0
		11:8	reserved	Reserved	0x0
		7:4	syncsel_pap	7:4 Select the sync for the PA Protection block. bit0 = '0' bit1 = sysref bit2 = sync_out from JESD bit3 = sif_sync 0x0	0x0
		3:0	syncsel_fir5a	Select the sync for the small fractional delay FIR filter coefficient loading. bit0 = '0' bit1 = sysref bit2 = sync_out from JESD bit3 = sif_sync	0x0

**Table 64. Register Name: config33 – Address: 0x21, Default: 0x0000**

Register Name	Addr (Hex)	Bit	Name	Function	Default Value
config33	0x21	15:0	reserved	Reserved	0x0000

**Table 65. Register Name: config34 – Address: 0x22, Default: 0x1B1B**

Register Name	Addr (Hex)	Bit	Name	Function	Default Value
config34	0x22	15:14	patha_in_sel	This selects the word used for the path A input. 00 = Sample 0 from JESD is selected for data path A 01 = Sample 1 from JESD is selected for data path A 10 = Sample 2 from JESD is selected for data path A 11 = Sample 3 from JESD is selected for data path A	00
		13:12	pathb_in_sel	This selects the word used for the path B input. 00 = Sample 0 from JESD is selected for data path B 01 = Sample 1 from JESD is selected for data path B 10 = Sample 2 from JESD is selected for data path B 11 = Sample 3 from JESD is selected for data path B	01
		11:10	pathc_in_sel	This selects the word used for the path C input. 00 = Sample 0 from JESD is selected for data path C 01 = Sample 1 from JESD is selected for data path C 10 = Sample 2 from JESD is selected for data path C 11 = Sample 3 from JESD is selected for data path C	10
		9:8	pathd_in_sel	This selects the word used for the path D input. 00 = Sample 0 from JESD is selected for data path D 01 = Sample 1 from JESD is selected for data path D 10 = Sample 2 from JESD is selected for data path D 11 = Sample 3 from JESD is selected for data path D	11
		7:6	patha_out_sel	This selects the word used for the DACA output. 00 = data path A goes to DACA 01 = data path B goes to DACA 10 = data path C goes to DACA 11 = data path D goes to DACA	00
		5:4	pathb_out_sel	This selects the word used for the DACB output. 00 = data path A goes to DACB 01 = data path B goes to DACB 10 = data path C goes to DACB 11 = data path D goes to DACB	01
		3:2	pathc_out_sel	This selects the word used for the DACC output. 00 = data path A goes to DACC 01 = data path B goes to DACC 10 = data path C goes to DACC 11 = data path D goes to DACC	10
		1:0	pathd_out_sel	This selects the word used for the DACD output. 00 = data path A goes to DACD 01 = data path B goes to DACD 10 = data path C goes to DACD 11 = data path D goes to DACD	11

**Table 66. Register Name: config35 – Address: 0x23, Default: 0xFFFF**

Register Name	Addr (Hex)	Bit	Name	Function	Default Value
config35	0x23	15:0	sleep_cntl	This controls the routing of the SLEEP pin signal to different blocks. Assertion means that the SLEEP signal will be sent to the block. These bits do not override the SIF bits, just the SLEEP signal from the pin. When asserted, bit15 through bit9 = Not used bit8 = Allows the Band gap over R to sleep ( <b>BUG... in this PG it is hooked to bit7</b> ) bit7 = Allows the Bias OP Amp to sleep bit6 = Allows the TEMP Sensor to sleep bit5 = Allows the PLL to sleep bit4 = Allows the CLK_RECV to sleep bit3 = Allows DACD to sleep bit2 = Allows DACC to sleep bit1 = Allows DACB to sleep bit0 = Allows DACA to sleep	0xFFFF

**Table 67. Register Name: config36 – Address: 0x24, Default: 0x0000**

Register Name	Addr (Hex)	Bit	Name	Function	Default Value
config36	0x24	15:13	reserved	Reserved	000
		12:7	reserved	Reserved	000000
		6:4	cdvrser_sysref_mode	Determines how SYSREF is used to sync the clock dividers in the device. 000 = Don't use SYSREF pulse 001 = Use all SYSREF pulses 010 = Use only the next SYSREF pulse 011 = Skip one SYSREF pulse then use only the next one 100 = Skip one SYSREF pulse then use all pulses.	000
		3:2	reserved	Reserved	00
		1:0	reserved	Reserved	00

**Table 68. Register Name: config37 – Address: 0x25, Default: 0x8000**

Register Name	Addr (Hex)	Bit	Name	Function	Default Value
config37	0x25	15:13	clkjesd_div	This controls the amount of dividing down the DACCLK gets to generate the JESD clock. It is independent of the interpolation because of the different JESD interfaces. "000" : DACCLK "001" : div2 "010" : div4 "011" : div8 "100" : div16 "101" : div32 "110" : always 1 "111" : always 0	100
		12:10	reserved	Reserved	000
		9:7	reserved	Reserved	000
		6:4	reserved	Reserved	000
		3:1	reserved	Reserved	000
		0	reserved	Reserved	0

**Table 69. Register Name: config38 – Address: 0x26, Default: 0x0000**

Register Name	Addr (Hex)	Bit	Name	Function	Default Value
config38	0x26	15:12	dither_ena	Turns on DITHER block for each data path bit15 = data path D bit14 = data path C bit13 = data path B bit12 = data path A	0000
		11:8	dither_mixer_ena	Turns on the FS/2 mixer at the output of the CIC in the DITHER block. bit11 = data path D bit10 = data path C bit9 = data path B bit8 = data path A	0000
		7:4	dither_sra_sel	Select the amount of dithering added to the signal. 0 is the maximum dithering.	0000
		3:2	reserved	Reserved	00
		1	reserved	Reserved	0
		0	reserved	Reserved	0

**Table 70. Register Name: config39 – Address: 0x27, Default: 0x0000**

Register Name	Addr (Hex)	Bit	Name	Function	Default Value
config39	0x27	15:0	reserved	Reserved	0x0000

**Table 71. Register Name: config40 – Address: 0x28, Default: 0x0000**

Register Name	Addr (Hex)	Bit	Name	Function	Default Value
config40 WRITE TO CLEAR	0x28	15:0	reserved	Reserved	0x0000

**Table 72. Register Name: config41 – Address: 0x29, Default: 0x0000**

Register Name	Addr (Hex)	Bit	Name	Function	Default Value
config41	0x29	15:0	reserved	Reserved	0xFFFF

**Table 73. Register Name: config42 – Address: 0x2A, Default: 0x0000**

Register Name	Addr (Hex)	Bit	Name	Function	Default Value
config42	0x2A	15:0	reserved	Reserved	0000

**Table 74. Register Name: config43 – Address: 0x2B, Default: 0x0000**

Register Name	Addr (Hex)	Bit	Name	Function	Default Value
config43	0x2B	15:0	reserved	Reserved	0x0000

**Table 75. Register Name: config44 – Address: 0x2C, Default: 0x0000**

Register Name	Addr (Hex)	Bit	Name	Function	Default Value
config44	0x2C	15:0	reserved	Reserved	0000

**Table 76. Register Name: config45 – Address: 0x2D, Default: 0x0000**

Register Name	Addr (Hex)	Bit	Name	Function	Default Value
config45	0x2D	15	reserved	Reserved	0
		14:4	reserved	Reserved	0000000000
		3	pap_dlylen_sel	Select the length of the PAP average: 0 : 64 samples 1 : 128 samples	0
		2:0	pap_gain	The amount of attenuation to apply when the threshold for PAP is met: 000 : no attenuation 001 : divide by 2 010 : divided by 4 011 : divided by 8 100 : divided by 16 101 : no attenuation 110 : no attenuation 111 : no attenuation	000

**Table 77. Register Name: config46 – Address: 0x2E, Default: 0xFFFF**

Register Name	Addr (Hex)	Bit	Name	Function	Default Value
config46	0x2E	15:0	pap_vth	The threshold value for the PA protection logic. When the power measurement is greater than this activate the PA protection logic.	0xFFFF

**Table 78. Register Name: config47 – Address: 0x2F, Default: 0x0004**

Register Name	Addr (Hex)	Bit	Name	Function	Default Value
config47	0x2F	15	reserved	Reserved	0
		14	titest_dieid_read_ena	When asserted, the die ID can be read out after fuse autoloading is finished on register 100-107. When de-asserted normal function of the registers is read out.	0
		13	reserved	Reserved	0
		12:3	reserved	Reserved	0000000000
		2	reserved	Reserved	1
		1	reserved	Reserved	0
		0	sifdac_ena	When asserted the DAC output is set to the value in register sifdac.	0

**Table 79. Register Name: config48 – Address: 0x30, Default: 0x0000**

Register Name	Addr (Hex)	Bit	Name	Function	Default Value
config48	0x30	15:0	sifdc	This is the value that is sent to the digital blocks when register sifdac_ena is asserted.	0x0000

**Table 80. Register Name: config49 – Address: 0x31, Default: 0x0000**

Register Name	Addr (Hex)	Bit	Name	Function	Default Value
config49	0x31	15:13	lockdet_adj	Adjusts the sensitivity of the DAC PLL lock detector; 4 settings from 000 to 011. The 011 setting has the widest lock detection window, tolerating more jitter while reporting a lock. The 000 setting has a narrow window and will indicate an unlocked state more often.	000
		12	pll_reset	When set, the M divider, N divider and PFD are held reset.	0
		11	pll_ndivsync_ena	When on, the SYSREF input is used to sync the N dividers of the PLL.	0
		10	pll_ena	Enables the PLL output as the DAC clock when set; the clock provided at the DACCLKP/N is used as the PLL reference clock. When cleared, the PLL is bypassed and the clock provided at the DACCLKP/N pins is used as the DAC clock	0 FUSE controlled
		9:8	pll_cp	Must be set to 00 for proper PLL operation	00
		7:3	pll_n	Reference clock divider; divide by is N+1	00000
		2:0	memin_pll_lfvolt	Indicates the loop filter voltage; 111 is max, 000 is min. When the PLL is correctly programmed, this will read 011 or 100 for a centered loop filter voltage.	000 READ ONLY

**Table 81. Register Name: config50 – Address: 0x32, Default: 0x0000**

Register Name	Addr (Hex)	Bit	Name	Function	Default Value
config50	0x32	15:8	PLL_M	VCO feedback divider; divide by is M+1	00000000
		7:4	PLL_P	VCO prescaler divider; 0000 : div by 2 0001 : div by 3 0010 : div by 4 0011 : div by 5 0100 : div by 6 0101 : div by 7 0110 : div by 8 0111 : div by 9 1000 : div by 4 1001 : div by 6 1010 : div by 8 1011 : div by 10 1100 : div by 12	0000
		3:0	reserved	Reserved	0000

**Table 82. Register Name: config51 – Address: 0x33, Default: 0x0100**

Register Name	Addr (Hex)	Bit	Name	Function	Default Value
config51	0x33	15	pll_vcosel	4GHz VCO selected when set, 5GHz VCO selected when cleared.	0
		14:9	pll_vco	VCO frequency range control; 000000 is fmin, 11111 is fmax	000000
		8:7	pll_vcoitune	VCO core bias current adjustment; 00 is 7mA, 01 is 8.4mA, 10 is 9.8mA, 11 is 11.2mA.	10
		6:2	pll_cp_adj	adjusts the charge pump current; 0 to 1.55mA is 50µA steps. Setting to 00000 will hold the LPF pin at 0V.	00000
		1:0	reserved	Reserved	00

**Table 83. Register Name: config52 – Address: 0x34, Default: 0x0000**

Register Name	Addr (Hex)	Bit	Name	Function	Default Value
config52	0x34	15	syncb_lvds_ lopwrb	SYNCB LVDS Output current control LSB; allows output current to be scaled from ~2mA to ~4mA	0
		14	syncb_lvds_ lopwra	SYNCB LVDS Output current control MSB; allows output current to be scaled from ~2mA to ~4mA	0
		13	syncb_lvds_ lpsel	SYNCB LVDS output on chip termination control; 100 Ω when cleared, 200 Ω when set.	0
		12	syncb_lvds_ effuse_sel	Enabled SYNCB LVDS bias bandgap reference voltage to the ATEST multiplexer. ATEST must be set to 111001 to enable this output.	0
		11:10	reserved	Reserved	00
		9	reserved	Reserved	0
		8	syncb_lvds_ sleep	The SYNCB LVDS output is in power down when set, active when cleared.	0
		7	syncb_lvds_ sub_ena	SYNCB LVDS output common mode is 1.2V when cleared, 0.9V when set.	0
		6:0	reserved	Reserved	0000000

**Table 84. Register Name: config53 – Address: 0x35, Default: 0x0000**

Register Name	Addr (Hex)	Bit	Name	Function	Default Value
config53	0x35	15:12	reserved	Reserved	0000
		11:8	reserved	Reserved	0000
		7:2	reserved	Reserved	000000
		1:0	reserved	Reserved	00

**Table 85. Register Name: config54 – Address: 0x36, Default: 0x0000**

Register Name	Addr (Hex)	Bit	Name	Function	Default Value
config54	0x36	15:0	reserved	Reserved	0x0000

**Table 86. Register Name: config55 – Address: 0x37, Default: 0x0000**

Register Name	Addr (Hex)	Bit	Name	Function	Default Value
config55	0x37	15:0	reserved	Reserved	0x0000

**Table 87. Register Name: config56 – Address: 0x38, Default: 0x0000**

Register Name	Addr (Hex)	Bit	Name	Function	Default Value
config56	0x38	15:0	reserved	Reserved	0x0000

**Table 88. Register Name: config57 – Address: 0x39, Default: 0x0000**

Register Name	Addr (Hex)	Bit	Name	Function	Default Value
config57	0x39	15:0	reserved	Reserved	0x0000

**Table 89. Register Name: config58 – Address: 0x3A, Default: 0x0000**

Register Name	Addr (Hex)	Bit	Name	Function	Default Value
config58	0x3A	15:0	reserved	Reserved	0x0000



**Table 90. Register Name: config59 – Address: 0x3B, Default: 0x0000**

Register Name	Addr (Hex)	Bit	Name	Function	Default Value
config59	0x3B	15	serdes_clk_sel	Select either the DAC PLL output or the DACCLK from the pins to be the SerDes PLL reference divider input clock.	0
		14:11	serdes_refclk_div	The divide amount for the serdes PLL reference clock divider. The divider amount is serdes_refclk_div plus one.	0000
		10:2	reserved	Reserved	000000000
		1:0	reserved	Reserved	00

**Table 91. Register Name: config60 – Address: 0x3C, Default: 0x0000**

Register Name	Addr (Hex)	Bit	Name	Function	Default Value
config60	0x3C	15:0	rw_cfgpll	Control the PLL of the SerDes. Bit15 – ENDIVCLK, enables output of a divide-by-5 of PLL clock. Bit14:13 – reserved. Bit12:11 – LB, specify loop bandwidth settings. Bit10 – SLEEPPLL, puts the PLL into sleep state when high. Bit9 – VRANGE, select between high and low VCO. Bit8:1 – MPY, select PLL multiply factor between 4 and 25. Bit0 – reserved.	0x0000

**Table 92. Register Name: config61 – Address: 0x3D, Default: 0x0000**

Register Name	Addr (Hex)	Bit	Name	Function	Default Value
config61	0x3D	15	reserved	Reserved	0
		14:0	rw_cfgrx0	Upper 15 bits of the configuration info for SerDes receivers. Bit14:1 – TESTPATT, Enables and selects verification of one of three 2 PRBS patterns, a user defined pattern or a clock test pattern. Bit11 – reserved Bit10 – reserved Bit9:8 – reserved Bit7 – ENOC, enable samplers offset compensation. Bit6 – EQHLD, hold the equalizer in its current status. Bit5:3 – EQ, enable and configure the equalizer to compensate the loss in the transmission media. Bit2:0 – CDR, configure the clock/data recovery algorithm.	000000000000000

**Table 93. Register Name: config62 – Address: 0x3E, Default: 0x0000**

Register Name	Addr (Hex)	Bit	Name	Function	Default Value
config62	0x3E	15:0	rw_cfgrx0	Lower 16 bits of the configuration info for SerDes receivers. Bit15:1 – LOS, enable loss of signal detection. 3 Bit12:1 – reserved. 1 Bit10:8 – TERM, select input termination options for serial lanes. <b>Note: AC coupling is recommended for JESD204B compliance.</b> Bit7 – reserved Bit6:5 – RATE, operating rate, select full, half, quarter or eighth rate operation. Bit4:2 – BUSWIDTH, select the parallel interface width (16 bit or 20bit). <b>Note: 16bit is not compatible with JESD204B.</b> Bit1 SLEEPRX, powers the receiver down into sleep (fast power up) state when high. Bit0 – reserved.	0x0000

**Table 94. Register Name: config63 – Address: 0x3F, Default: 0x0000**

Register Name	Addr (Hex)	Bit	Name	Function	Default Value
config63	0x3F	15:8	Not Used	Not Used	0x00
		7:0	INVPAIR	Allows the PN pairs of the SerDes lanes to be inverted. bit7 = lane7 bit6 = lane6 bit5 = lane5 bit4 = lane4 bit3 = lane3 bit2 = lane2 bit1 = lane1 bit0 = lane0	0x00

**Table 95. Register Name: config64 – Address: 0x40, Default: 0x0000**

Register Name	Addr (Hex)	Bit	Name	Function	Default Value
config64	0x40	15:0	reserved	Reserved	0x0000

**Table 96. Register Name: config65 – Address: 0x41, Default: 0x0000**

Register Name	Addr (Hex)	Bit	Name	Function	Default Value
config65 READ ONLY	0x41	15:0	errorcnt_link0	This is the error count for link0. What is counted as an error is determined by error_ena_link0. This is a 16bit value that is cleared when a JESD synchronization is performed or err_cnt_clr_link0 is programmed to a '1'.	0x0000

**Table 97. Register Name: config66 – Address: 0x42, Default: 0x0000**

Register Name	Addr (Hex)	Bit	Name	Function	Default Value
config66 READ ONLY	0x42	15:0	errorcnt_link1	This is the error count for link1. What is counted as an error is determined by error_ena_link1. This is a 16bit value that is cleared when a JESD synchronization is performed or err_cnt_clr_link0 is programmed to a '1'.	0x0000

**Table 98. Register Name: config67 – Address: 0x43, Default: 0x0000**

Register Name	Addr (Hex)	Bit	Name	Function	Default Value
config67 READ ONLY	0x43	15:0	errorcnt_link2	This is the error count for link2. What is counted as an error is determined by error_ena_link2. This is a 16bit value that is cleared when a JESD synchronization is performed or err_cnt_clr_link0 is programmed to a '1'.	0x0000

**Table 99. Register Name: config68 – Address: 0x44, Default: 0x0000**

Register Name	Addr (Hex)	Bit	Name	Function	Default Value
config68 READ ONLY	0x44	15:0	errorcnt_link3	This is the error count for link3. What is counted as an error is determined by error_ena_link3. This is a 16bit value that is cleared when a JESD synchronization is performed or err_cnt_clr_link0 is programmed to a '1'.	0x0000

**Table 100. Register Name: config69 – Address: 0x45, Default: 0x0000**

Register Name	Addr (Hex)	Bit	Name	Function	Default Value
config69	0x45	15:0	reserved	Reserved	0x0000

**Table 101. Register Name: config70 – Address: 0x46, Default: 0x0120**

Register Name	Addr (Hex)	Bit	Name	Function	Default Value
config70	0x46	15:11	lid0	The JESD ID for JESD lane 0.	00000
		10:6	lid1	The JESD ID for JESD lane 1.	00001
		5:1	lid2	The JESD ID for JESD lane 2.	00010
		0	reserved	Reserved	0

**Table 102. Register Name: config71 – Address: 0x47, Default: 0x3450**

Register Name	Addr (Hex)	Bit	Name	Function	Default Value
config71	0x47	15:11	lid3	The JESD ID for JESD lane 3.	00011
		10:6	lid4	The JESD ID for JESD lane 4.	00100
		5:1	lid5	The JESD ID for JESD lane 5.	00101
		0	reserved	Reserved	0

**Table 103. Register Name: config72 – Address: 0x48, Default: 0x31C3**

Register Name	Addr (Hex)	Bit	Name	Function	Default Value
config72	0x48	15:11	lid6	The JESD ID for JESD lane 6.	00110
		10:6	lid7	The JESD ID for JESD lane 7.	00111
		5:4	reserved	reserved	00
		3:1	subclassv	Selects the JESD subclass supported. <b>Note: "001" is subclass 1 and this is the only mode supported</b>	001
		0	jesdv	Selects the version of JESD supported (0=A, 1=B) <b>Note: JESD 204B is only supported version.</b>	1

**Table 104. Register Name: config73 – Address: 0x49, Default: 0x0000**

Register Name	Addr (Hex)	Bit	Name	Function	Default Value
config73	0x49	15:0	link_assign	Each JESD lane can be assigned to any of the 4 links. There are two bits for each lane: "00"=link0, "01"=link1, "10"=link2 and "11"=link3 bits(15:14) : JESD lane7 link selection bits(13:12) : JESD lane6 link selection bits(11:10) : JESD lane5 link selection bits(9:8) : JESD lane4 link selection bits(7:6) : JESD lane3 link selection bits(5:4) : JESD lane2 link selection bits(3:2) : JESD lane1 link selection bits(1:0) : JESD lane0 link selection	0x0000

**Table 105. Register Name: config74 – Address: 0x4A, Default: 0x001E**

Register Name	Addr (Hex)	Bit	Name	Function	Default Value
config74	0x4A	15:8	lane_ena	Turn on each SerDes lane as needed. Signal is active high. bit15 : SerDes lane7 enable bit14 : SerDes lane6 enable bit13 : SerDes lane5 enable bit12 : SerDes lane4 enable bit11 : SerDes lane3 enable bit10 : SerDes lane2 enable bit9 : SerDes lane1 enable bit8 : SerDes lane0 enable	0x00
		7:6	jesd_test_seq	Set to select and verify link layer test sequences. The error for these sequences comes out the lane alarms bit0. 1= fail and 0 = pass. 00 : test sequence disabled 01 : verify repeating D.21.5 high frequency pattern for random jitter 10 : verify repeating K.28.5 mixed frequency pattern for deterministic jitter 11 : verify repeating ILA sequence	00
		5	dual	Turn on "DUAL DAC" mode. This disables the clocks to the C and D data paths, reducing the power of the DIG block.	0
		4:1	init_state	Put the JESD block into "INIT_STATE" mode when high. During this mode the JESD can be programmed and its outputs will stay at zero. <b>NOTE: See the JESD description of the correct startup sequence.</b>	1111
		0	jesd_reset_n	Reset the JESD block when low. <b>NOTE: See the JESD description of the correct startup sequence.</b>	0

**Table 106. Register Name: config75 – Address: 0x4B, Default: 0x0000**

Register Name	Addr (Hex)	Bit	Name	Function	Default Value
config75	0x4B	15:13	reserved	Reserved	000
		12:8	rbd_m1	This controls the amount of elastic buffers being used in the JESD. Larger numbers will mean more latency, but smaller numbers may not hold enough data to capture the input skew. This value must always be $\leq k\_m1$	00000
		7:0	f_m1	This is the number of octets in the frame. The DAC37J82/DAC38J82 only supports 1,2,4 or 8 octets per frame so the only valid values are 0,1,3, and 7.	0x00

**Table 107. Register Name: config76 – Address: 0x4C, Default: 0x0000**

Register Name	Addr (Hex)	Bit	Name	Function	Default Value
config76	0x4C	15:13	reserved	Reserved	000
		12:8	k_m1	This is the number of frames in a multi-frame. The range is 0-31.	00000
		7	reserved	Reserved	0
		6	reserved	Reserved	0
		5	reserved	Reserved	0
		4:0	l_m1	This is the number of lanes used by the JESD. Possible values are 0-7.	00000

**Table 108. Register Name: config77 – Address: 0x4D, Default: 0x0300**

Register Name	Addr (Hex)	Bit	Name	Function	Default Value
config77	0x4D	15:8	m_m1	This is the number of converters per link. <b>NOTE: Valid programmed values are 0, 1 and 3.</b>	0x03
		7:5	reserved	Reserved	000
		4:0	s_m1	This is the number of converter samples per frame. <b>NOTE: Valid programming is 0 or 1.</b>	00000

**Table 109. Register Name: config78 – Address: 0x4E, Default: 0x0F0F**

Register Name	Addr (Hex)	Bit	Name	Function	Default Value
config78	0x4E	15:13	reserved	Reserved	000
		12:8	nprime_m1	This is the number of adjusted bits per sample. <b>NOTE: 15 is the only valid value.</b>	01111
		7	reserved	Reserved	0
		6	hd	High Density mode for the JESD. When asserted samples are split across lanes.	0
		5	scr	Turns on the scrambler function in the JESD block.	0
		4:0	n_m1	This is the number of bits per sample. <b>NOTE: 15 is the only valid value.</b>	01111

**Table 110. Register Name: config79 – Address: 0x4F, Default: 0x1CC1**

Register Name	Addr (Hex)	Bit	Name	Function	Default Value
config79	0x4F	15:8	match_data	The character to match. Normally it is a /R/=/K28.0/=0x1C, but the user can program it to any character.	00011100
		7	match_specific	Match a specified character to start JESD buffering when '1'. If programmed to '0' then the first non-K will start the buffering.	1
		6	match_ctrl	When asserted, the match character is a CONTROL character instead of a DATA character.	1
		5	no_lane_sync	Assert if the TX side does not support lane initialization. This way the RX won't flag errors in the configuration portion of the ILA.	0
		4:1	reserved	Reserved	0000
		0	jesd_commaalign_ena	always "1"	1

**Table 111. Register Name: config80 – Address: 0x50, Default: 0x0000**

Register Name	Addr (Hex)	Bit	Name	Function	Default Value
config80	0x50	15:12	adjcnt_link0	Lane configuration data for link0. <b>Not used by DAC37J82/DAC38J82 except for lane configuration checking.</b>	0000
		11	adjdir_link0	Lane configuration data for link0. <b>Not used by DAC37J82/DAC38J82 except for lane configuration checking.</b>	0
		10:7	bid_link0	Lane configuration data for link0. <b>Not used by DAC37J82/DAC38J82 except for lane configuration checking.</b>	0000
		6:2	cf_link0	Lane configuration data for link0. <b>Not used by DAC37J82/DAC38J82 except for lane configuration checking.</b>	00000
		1:0	cs_link0	Lane configuration data for link0. <b>Not used by DAC37J82/DAC38J82 except for lane configuration checking.</b>	00

**Table 112. Register Name: config81 – Address: 0x51, Default: 0x00FF**

Register Name	Addr (Hex)	Bit	Name	Function	Default Value
config81	0x51	15:8	did_link0	Lane configuration data for link0. <b>Not used by DAC37J82/DAC38J82 except for lane configuration checking.</b>	0x00
		7:0	sync_request_ena_link0	These bits select which errors cause a sync request. Sync requests take priority over the error notification, so if sync request isn't desired, set these bits to a '0'. bit7 = multi-frame alignment error bit6 = frame alignment error bit5 = link configuration error bit4 = elastic buffer overflow (bad RBD value) bit3 = elastic buffer end char mismatch (match_ctrl match_data) bit2 = code synchronization error bit1 = 8b/10b not-in-table code error bit0 = 8b/10b disparity error	0xFF

**Table 113. Register Name: config82 – Address: 0x52, Default: 0x00FF**

Register Name	Addr (Hex)	Bit	Name	Function	Default Value
config82	0x52	15:10	reserved	Reserved	000000
		9	disable_err_report_link0	Assertion means that errors will not be reported on the sync_n output.	0
		8	phadj_link0	Lane configuration data for link0. <b>Not used by DAC37J82/DAC38J82 except for lane configuration checking.</b>	0
		7:0	error_ena_link0	These bits select the errors generated are counted in the err_c for the link. The bits also control what signals are sent out the pad_syncb pin for error notification. bit7 = multi-frame alignment error bit6 = frame alignment error bit5 = link configuration error bit4 = elastic buffer overflow (bad RBD value) bit3 = elastic buffer end char mismatch (match_ctrl match_data) bit2 = code synchronization error bit1 = 8b/10b not-in-table code error bit0 = 8b/10b disparity error	0xFF

**Table 114. Register Name: config83 – Address: 0x53, Default: 0x0000**

Register Name	Addr (Hex)	Bit	Name	Function	Default Value
config83	0x53	15:12	adjcnt_link1	Lane configuration data for link1. <b>Not used by DAC37J82/DAC38J82 except for lane configuration checking.</b>	0000
		11	adjdir_link1	Lane configuration data for link1. <b>Not used by DAC37J82/DAC38J82 except for lane configuration checking.</b>	0
		10:7	bid_link1	Lane configuration data for link1. <b>Not used by DAC37J82/DAC38J82 except for lane configuration checking.</b>	0000
		6:2	cf_link1	Lane configuration data for link1. <b>Not used by DAC37J82/DAC38J82 except for lane configuration checking.</b>	00000
		1:0	cs_link1	Lane configuration data for link1. <b>Not used by DAC37J82/DAC38J82 except for lane configuration checking.</b>	00

**Table 115. Register Name: config84 – Address: 0x54, Default: 0x00FF**

Register Name	Addr (Hex)	Bit	Name	Function	Default Value
config84	0x54	15:8	did_link1	Lane configuration data for link1. <b>Not used by DAC37J82/DAC38J82 except for lane configuration checking.</b>	0x00
		7:0	sync_request_ena_link1	These bits select which errors cause a sync request. Sync requests take priority over the error notification, so if sync request isn't desired, set these bits to a '0'. bit7 = multi-frame alignment error bit6 = frame alignment error bit5 = link configuration error bit4 = elastic buffer overflow (bad RBD value) bit3 = elastic buffer end char mismatch (match_ctrl match_data) bit2 = code synchronization error bit1 = 8b/10b not-in-table code error bit0 = 8b/10b disparity error	0xFF

**Table 116. Register Name: config85 – Address: 0x55, Default: 0x00FF**

Register Name	Addr (Hex)	Bit	Name	Function	Default Value
config85	0x55	15:10	reserved	Reserved	000000
		9	disable_err_report_link1	Assertion means that errors will not be reported on the sync_n output.	0
		8	phadj_link1	Lane configuration data for link1. <b>Not used by DAC37J82/DAC38J82 except for lane configuration checking.</b>	0
		7:0	error_ena_link1	These bits select the errors generated are counted in the err_cnt for the link. The bits also control what signals are sent out the pad_synchb pin for error notification. bit7 = multi-frame alignment error bit6 = frame alignment error bit5 = link configuration error bit4 = elastic buffer overflow (bad RBD value) bit3 = elastic buffer end char mismatch (match_ctrl match_data) bit2 = code synchronization error bit1 = 8b/10b not-in-table code error bit0 = 8b/10b disparity error	0xFF

**Table 117. Register Name: config86 – Address: 0x56, Default: 0x0000**

Register Name	Addr (Hex)	Bit	Name	Function	Default Value
config86	0x56	15:12	adjcnt_link2	Lane configuration data for link2. <b>Not used by DAC37J82/DAC38J82 except for lane configuration checking.</b>	0000
		11	adjdir_link2	Lane configuration data for link2. <b>Not used by DAC37J82/DAC38J82 except for lane configuration checking.</b>	0
		10:7	bid_link2	Lane configuration data for link2. <b>Not used by DAC37J82/DAC38J82 except for lane configuration checking.</b>	0000
		6:2	cf_link2	Lane configuration data for link2. <b>Not used by DAC37J82/DAC38J82 except for lane configuration checking.</b>	00000
		1:0	cs_link2	Lane configuration data for link2. <b>Not used by DAC37J82/DAC38J82 except for lane configuration checking.</b>	00

**Table 118. Register Name: config87 – Address: 0x57, Default: 0x00FF**

Register Name	Addr (Hex)	Bit	Name	Function	Default Value
config87	0x57	15:8	did_link2	Lane configuration data for link2. Not used by DAC37J82/DAC38J82 except for lane configuration checking.	0x00
		7:0	sync_request_ena_link2	These bits select which errors cause a sync request. Sync requests take priority over the error notification, so if sync request isn't desired, set these bits to a '0'. bit7 = multi-frame alignment error bit6 = frame alignment error bit5 = link configuration error bit4 = elastic buffer overflow (bad RBD value) bit3 = elastic buffer end char mismatch (match_ctrl match_data) bit2 = code synchronization error bit1 = 8b/10b not-in-table code error bit0 = 8b/10b disparity error	0xFF

**Table 119. Register Name: config88 – Address: 0x58, Default: 0x00FF**

Register Name	Addr (Hex)	Bit	Name	Function	Default Value
config88	0x58	15:10	reserved	Reserved	000000
		9	disable_err_report_link2	Assertion means that errors will not be reported on the sync_n output.	0
		8	phadj_link2	Lane configuration data for link2. <b>Not used by DAC37J82/DAC38J82 except for lane configuration checking.</b>	0
		7:0	error_ena_link2	These bits select the errors generated are counted in the err_cnt for the link. The bits also control what signals are sent out the pad_syncb pin for error notification. bit7 = multi-frame alignment error bit6 = frame alignment error bit5 = link configuration error bit4 = elastic buffer overflow (bad RBD value) bit3 = elastic buffer end char mismatch (match_ctrl match_data) bit2 = code synchronization error bit1 = 8b/10b not-in-table code error bit0 = 8b/10b disparity error	0xFF



**Table 120. Register Name: config89 – Address: 0x59, Default: 0x0000**

Register Name	Addr (Hex)	Bit	Name	Function	Default Value
config89	0x59	15:12	adjcnt_link3	Lane configuration data for link3. <b>Not used by DAC37J82/DAC38J82 except for lane configuration checking.</b>	0000
		11	adjdir_link3	Lane configuration data for link3. <b>Not used by DAC37J82/DAC38J82 except for lane configuration checking.</b>	0
		10:7	bid_link3	Lane configuration data for link3. <b>Not used by DAC37J82/DAC38J82 except for lane configuration checking.</b>	0000
		6:2	cf_link3	Lane configuration data for link3. <b>Not used by DAC37J82/DAC38J82 except for lane configuration checking.</b>	00000
		1:0	cs_link3	Lane configuration data for link3. <b>Not used by DAC37J82/DAC38J82 except for lane configuration checking.</b>	00

**Table 121. Register Name: config90 – Address: 0x5A, Default: 0x00FF**

Register Name	Addr (Hex)	Bit	Name	Function	Default Value
config90	0x5A	15:8	did_link3	Lane configuration data for link3. <b>Not used by DAC37J82/DAC38J82 except for lane configuration checking.</b>	0x00
		7:0	sync_request_ena_link3	These bits select which errors cause a sync request. Sync requests take priority over the error notification, so if sync request isn't desired, set these bits to a '0'. bit7 = multi-frame alignment error bit6 = frame alignment error bit5 = link configuration error bit4 = elastic buffer overflow (bad RBD value) bit3 = elastic buffer end char mismatch (match_ctrl match_data) bit2 = code synchronization error bit1 = 8b/10b not-in-table code error bit0 = 8b/10b disparity error	0xFF

**Table 122. Register Name: config91 – Address: 0x5B, Default: 0x00FF**

Register Name	Addr (Hex)	Bit	Name	Function	Default Value
config91	0x5B	15:10	reserved	Reserved	000000
		9	disable_err_report_link3	Assertion means that errors will not be reported on the sync_n output.	0
		8	phadj_link3	Lane configuration data for link3. <b>Not used by DAC37J82/DAC38J82 except for lane configuration checking.</b>	0
		7:0	error_ena_link3	These bits select the errors generated are counted in the err_cnt for the link. The bits also control what signals are sent out the pad_syncb pin for error notification. bit7 = multi-frame alignment error bit6 = frame alignment error bit5 = link configuration error bit4 = elastic buffer overflow (bad RBD value) bit3 = elastic buffer end char mismatch (match_ctrl match_data) bit2 = code synchronization error bit1 = 8b/10b not-in-table code error bit0 = 8b/10b disparity error	0xFF

**Table 123. Register Name: config92 – Address: 0x5C, Default: 0x1111**

Register Name	Addr (Hex)	Bit	Name	Function	Default Value
config92	0x5C	15	err_cnt_clr_link3	A transition from 0≥1 causes the error_cnt for link3 to be cleared.	0
		14:12	sysref_mode_link3	Determines how SYSREF is used in the JESD synchronizing block. 000 = Don't use SYSREF pulse 001 = Use all SYSREF pulses 010 = Use only the next SYSREF pulse 011 = Skip one SYSREF pulse then use only the next one 100 = Skip one SYSREF pulse then use all pulses. 101 = Skip two SYSREF pulses then use only the next one 110 = Skip two SYSREF pulses then use all pulses.	001
		11	err_cnt_clr_link2	A transition from 0≥1 causes the error_cnt for link2 to be cleared.	0
		10:8	sysref_mode_link2	Determines how SYSREF is used in the JESD synchronizing block. 000 = Don't use SYSREF pulse 001 = Use all SYSREF pulses 010 = Use only the next SYSREF pulse 011 = Skip one SYSREF pulse then use only the next one 100 = Skip one SYSREF pulse then use all pulses. 101 = Skip two SYSREF pulses then use only the next one 110 = Skip two SYSREF pulses then use all pulses.	001
		7	err_cnt_clr_link1	A transition from 0≥1 causes the error_cnt for link1 to be cleared.	0
		6:4	sysref_mode_link1	Determines how SYSREF is used in the JESD synchronizing block. 000 = Don't use SYSREF pulse 001 = Use all SYSREF pulses 010 = Use only the next SYSREF pulse 011 = Skip one SYSREF pulse then use only the next one 100 = Skip one SYSREF pulse then use all pulses. 101 = Skip two SYSREF pulses then use only the next one 110 = Skip two SYSREF pulses then use all pulses.	001
		3	err_cnt_clr_link0	A transition from 0≥1 causes the error_cnt for link0 to be cleared.	0
		2:0	sysref_mode_link0	Determines how SYSREF is used in the JESD synchronizing block. 000 = Don't use SYSREF pulse 001 = Use all SYSREF pulses 010 = Use only the next SYSREF pulse 011 = Skip one SYSREF pulse then use only the next one 100 = Skip one SYSREF pulse then use all pulses. 101 = Skip two SYSREF pulses then use only the next one 110 = Skip two SYSREF pulses then use all pulses.	001

**Table 124. Register Name: config93 – Address: 0x5D, Default: 0x0000**

Register Name	Addr (Hex)	Bit	Name	Function	Default Value
config93	0x5D	15:0	reserved	Reserved	0x0000

**Table 125. Register Name: config94 – Address: 0x5E, Default: 0x0000**

Register Name	Addr (Hex)	Bit	Name	Function	Default Value
config94	0x5E	15:8	res1	Since these bits are reserved, these values are shared across all links for the checksum comparison against ILA values. <b>Not used by DAC37J82/DAC38J82 except for lane configuration checking.</b>	00000000
		7:0	res2	Since these bits are reserved, these values are shared across all links for the checksum comparison against ILA values. <b>Not used by DAC37J82/DAC38J82 except for lane configuration checking.</b>	00000000

**Table 126. Register Name: config95 – Address: 0x5F, Default: 0x0123**

Register Name	Addr (Hex)	Bit	Name	Function	Default Value
config95	0x5F	15	reserved	Reserved	0
		14:12	octetpath_sel(0)	These bits are used by the cross-bar switch to map any SerDes lane to any JESD lane. “000” = pass SerDes lane0 to JESD lane0 “001” = pass SerDes lane1 to JESD lane0 “010” = pass SerDes lane2 to JESD lane0 “011” = pass SerDes lane3 to JESD lane0 “100” = pass SerDes lane4 to JESD lane0 “101” = pass SerDes lane5 to JESD lane0 “110” = pass SerDes lane6 to JESD lane0 “111” = pass SerDes lane7 to JESD lane0	000
		11	reserved	Reserved	0
		10:8	octetpath_sel(1)	These bits are used by the cross-bar switch to map any SerDes lane to any JESD lane. “000” = pass SerDes lane0 to JESD lane1 “001” = pass SerDes lane1 to JESD lane1 “010” = pass SerDes lane2 to JESD lane1 “011” = pass SerDes lane3 to JESD lane1 “100” = pass SerDes lane4 to JESD lane1 “101” = pass SerDes lane5 to JESD lane1 “110” = pass SerDes lane6 to JESD lane1 “111” = pass SerDes lane7 to JESD lane1	001
		7	reserved	Reserved	0
		6:4	octetpath_sel(2)	These bits are used by the cross-bar switch to map any SerDes lane to any JESD lane. “000” = pass SerDes lane0 to JESD lane2 “001” = pass SerDes lane1 to JESD lane2 “010” = pass SerDes lane2 to JESD lane2 “011” = pass SerDes lane3 to JESD lane2 “100” = pass SerDes lane4 to JESD lane2 “101” = pass SerDes lane5 to JESD lane2 “110” = pass SerDes lane6 to JESD lane2 “111” = pass SerDes lane7 to JESD lane2	010
		3	reserved	Reserved	0
		2:0	octetpath_sel(3)	These bits are used by the cross-bar switch to map any SerDes lane to any JESD lane. “000” = pass SerDes lane0 to JESD lane3 “001” = pass SerDes lane1 to JESD lane3 “010” = pass SerDes lane2 to JESD lane3 “011” = pass SerDes lane3 to JESD lane3 “100” = pass SerDes lane4 to JESD lane3 “101” = pass SerDes lane5 to JESD lane3 “110” = pass SerDes lane6 to JESD lane3 “111” = pass SerDes lane7 to JESD lane3	011

**Table 127. Register Name: config96 – Address: 0x60, Default: 0x4567**

Register Name	Addr (Hex)	Bit	Name	Function	Default Value
config96	0x60	15	reserved	Reserved	0
		14:12	octetpath_sel(4)	These bits are used by the cross-bar switch to map any SerDes lane to any JESD lane. "000" = pass SerDes lane0 to JESD lane4 "001" = pass SerDes lane1 to JESD lane4 "010" = pass SerDes lane2 to JESD lane4 "011" = pass SerDes lane3 to JESD lane4 "100" = pass SerDes lane4 to JESD lane4 "101" = pass SerDes lane5 to JESD lane4 "110" = pass SerDes lane6 to JESD lane4 "111" = pass SerDes lane7 to JESD lane4	100
		11	reserved	Reserved	0
		10:8	octetpath_sel(5)	These bits are used by the cross-bar switch to map any SerDes lane to any JESD lane. "000" = pass SerDes lane0 to JESD lane5 "001" = pass SerDes lane1 to JESD lane5 "010" = pass SerDes lane2 to JESD lane5 "011" = pass SerDes lane3 to JESD lane5 "100" = pass SerDes lane4 to JESD lane5 "101" = pass SerDes lane5 to JESD lane5 "110" = pass SerDes lane6 to JESD lane5 "111" = pass SerDes lane7 to JESD lane5	101
		7	reserved	Reserved	0
		6:4	octetpath_sel(6)	These bits are used by the cross-bar switch to map any SerDes lane to any JESD lane. "000" = pass SerDes lane0 to JESD lane6 "001" = pass SerDes lane1 to JESD lane6 "010" = pass SerDes lane2 to JESD lane6 "011" = pass SerDes lane3 to JESD lane6 "100" = pass SerDes lane4 to JESD lane6 "101" = pass SerDes lane5 to JESD lane6 "110" = pass SerDes lane6 to JESD lane6 "111" = pass SerDes lane7 to JESD lane6	110
		3	reserved	Reserved	0
		2:0	octetpath_sel(7)	These bits are used by the cross-bar switch to map any SerDes lane to any JESD lane. "000" = pass SerDes lane0 to JESD lane7 "001" = pass SerDes lane1 to JESD lane7 "010" = pass SerDes lane2 to JESD lane7 "011" = pass SerDes lane3 to JESD lane7 "100" = pass SerDes lane4 to JESD lane7 "101" = pass SerDes lane5 to JESD lane7 "110" = pass SerDes lane6 to JESD lane7 "111" = pass SerDes lane7 to JESD lane7	111

**Table 128. Register Name: config97 – Address: 0x61, Default: 0x000F**

Register Name	Addr (Hex)	Bit	Name	Function	Default Value
config97	0x61	15	syncn_pol	Sets the polarity of the SYNC_N_AB and SYNC_N_CD outputs.	0
		14:2	reserved	Reserved	000
		11:8	syncncd_sel	Select which link sync_n outputs are ANDed together to generate the SYNC_N_CD CMOS output. bit0=link0 bit1=link1 bit2=link2 bit3=link3	0000
		7:4	syncnab_sel	Select which link sync_n outputs are ANDed together to generate the SYNC_N_AB CMOS output. bit0=link0 bit1=link1 bit2=link2 bit3=link3	0000
		3:0	syncn_sel	Select which link sync_n outputs are ANDed together to generate the SYNCB LVDS output. bit0=link0 bit1=link1 bit2=link2 bit3=link3	1111

**Table 129. Register Name: config98 – Address: 0x62, Default: 0x0000**

Register Name	Addr (Hex)	Bit	Name	Function	Default Value
config98	0x62	15	reserved	Reserved	0
		14:12	reserved	Reserved	000
		11:8	reserved	Reserved	0000
		7:0	reserved	Reserved	0x00

**Table 130. Register Name: config99 – Address: 0x63, Default: 0x0000**

Register Name	Addr (Hex)	Bit	Name	Function	Default Value
config99	0x63	15	reserved	Reserved	0
		14:12	reserved	Reserved	000
		11:8	reserved	Reserved	0000
		7:0	reserved	Reserved	0000

Addresses config100 – config107 are dual purpose registers. When config47(14) is set to a ‘1’ then config100 – config107 become the DIEID(127:0). Normal function (config47(14)=’0’) is shown below.

**Table 131. Register Name: config100 – Address: 0x64, Default: 0x0000**

Register Name	Addr (Hex)	Bit	Name	Function	Default Value
config100 WRITE TO CLEAR	0x64	15:8	alarm_l_ error(0)	Lane0 errors: bit15 = multiframe alignment error bit14 = frame alignment error bit13 = link configuration error bit12 = elastic buffer overflow (bad RBD value) bit11 = elastic buffer match error. The first non-/K/ doesn't match "match_ctrl" and "match_data" programmed values. bit10 = code synchronization error bit9 = 8b/10b not-in-table code error bit8 = 8b/10b disparity error	0x00
		7:4	Not Used	Not Used	0000
		3:0	alarm_fifo_ flags(0)	Lane0 FIFO errors: bit3 = write_error : Asserted if write request and FIFO is full bit2 = write_full : FIFO is FULL bit1 = read_error : Asserted if read request with empty FIFO bit0 = read_empty : FIFO is empty	0000

**Table 132. Register Name: config101 – Address: 0x65, Default: 0x0000**

Register Name	Addr (Hex)	Bit	Name	Function	Default Value
config101 WRITE TO CLEAR	0x65	15:8	alarm_l_ error(1)	Lane0 errors: bit15 = multiframe alignment error bit14 = frame alignment error bit13 = link configuration error bit12 = elastic buffer overflow (bad RBD value) bit11 = elastic buffer match error. The first non-/K/ doesn't match "match_ctrl" and "match_data" programmed values. bit10 = code synchronization error bit9 = 8b/10b not-in-table code error bit8 = 8b/10b disparity error	0x00
		7:4	Not Used	Not Used	0000
		3:0	alarm_fifo_ flags(0)	Lane0 FIFO errors: bit3 = write_error : Asserted if write request and FIFO is full bit2 = write_full : FIFO is FULL bit1 = read_error : Asserted if read request with empty FIFO bit0 = read_empty : FIFO is empty	0000

**Table 133. Register Name: config102 – Address: 0x66, Default: 0x0000**

Register Name	Addr (Hex)	Bit	Name	Function	Default Value
config102 WRITE TO CLEAR	0x66	15:8	alarm_lane_error(2)	Lane0 errors: bit15 = multiframe alignment error bit14 = frame alignment error bit13 = link configuration error bit12 = elastic buffer overflow (bad RBD value) bit11 = elastic buffer match error. The first non-/K/ doesn't match "match_ctrl" and "match_data" programmed values. bit10 = code synchronization error bit9 = 8b/10b not-in-table code error bit8 = 8b/10b disparity error	0x00
		7:4	reserved	Reserved	0000
		3:0	alarm_fifo_flags(0)	Lane0 FIFO errors: bit3 = write_error : Asserted if write request and FIFO is full bit2 = write_full : FIFO is FULL bit1 = read_error : Asserted if read request with empty FIFO bit0 = read_empty : FIFO is empty	0000

**Table 134. Register Name: config103 – Address: 0x67, Default: 0x0000**

Register Name	Addr (Hex)	Bit	Name	Function	Default Value
config103 WRITE TO CLEAR	0x67	15:8	alarm_land_error(3)	Lane0 errors: bit15 = multiframe alignment error bit14 = frame alignment error bit13 = link configuration error bit12 = elastic buffer overflow (bad RBD value) bit11 = elastic buffer match error. The first non-/K/ doesn't match "match_ctrl" and "match_data" programmed values. bit10 = code synchronization error bit9 = 8b/10b not-in-table code error bit8 = 8b/10b disparity error	0x00
		7:4	reserved	Reserved	0000
		3:0	alarm_fifo_flags(0)	Lane0 FIFO errors: bit3 = write_error : Asserted if write request and FIFO is full bit2 = write_full : FIFO is FULL bit1 = read_error : Asserted if read request with empty FIFO bit0 = read_empty : FIFO is empty	0000

**Table 135. Register Name: config104 – Address: 0x68, Default: 0x0000**

Register Name	Addr (Hex)	Bit	Name	Function	Default Value
config104 WRITE TO CLEAR	0x68	15:8	alarm_lane_error(4)	Lane0 errors: bit15 = multiframe alignment error bit14 = frame alignment error bit13 = link configuration error bit12 = elastic buffer overflow (bad RBD value) bit11 = elastic buffer match error. The first non-/K/ doesn't match "match_ctrl" and "match_data" programmed values. bit10 = code synchronization error bit9 = 8b/10b not-in-table code error bit8 = 8b/10b disparity error	0x00
		7:4	reserved	Reserved	0000
		3:0	alarm_fifo_flags(0)	Lane0 FIFO errors: bit3 = write_error : Asserted if write request and FIFO is full bit2 = write_full : FIFO is FULL bit1 = read_error : Asserted if read request with empty FIFO bit0 = read_empty : FIFO is empty	0000

**Table 136. Register Name: config105 – Address: 0x69, Default: 0x0000**

Register Name	Addr (Hex)	Bit	Name	Function	Default Value
config105 WRITE TO CLEAR	0x69	15:8	alarm_lane_error(5)	Lane0 errors: bit15 = multiframe alignment error bit14 = frame alignment error bit13 = link configuration error bit12 = elastic buffer overflow (bad RBD value) bit11 = elastic buffer match error. The first non-/K/ doesn't match "match_ctrl" and "match_data" programmed values. bit10 = code synchronization error bit9 = 8b/10b not-in-table code error bit8 = 8b/10b disparity error	0x00
		7:4	reserved	Reserved	0000
		3:0	alarm_fifo_flags(0)	Lane0 FIFO errors: bit3 = write_error : Asserted if write request and FIFO is full bit2 = write_full : FIFO is FULL bit1 = read_error : Asserted if read request with empty FIFO bit0 = read_empty : FIFO is empty	0000



**Table 137. Register Name: config106 – Address: 0x6A, Default: 0x0000**

Register Name	Addr (Hex)	Bit	Name	Function	Default Value
config106 WRITE TO CLEAR	0x6A	15:8	alarm_lane_error(6)	Lane0 errors: bit15 = multiframe alignment error bit14 = frame alignment error bit13 = link configuration error bit12 = elastic buffer overflow (bad RBD value) bit11 = elastic buffer match error. The first non-/K/ doesn't match "match_ctrl" and "match_data" programmed values. bit10 = code synchronization error bit9 = 8b/10b not-in-table code error bit8 = 8b/10b disparity error	0x00
		7:4	reserved	Reserved	0000
		3:0	alarm_fifo_flags(0)	Lane0 FIFO errors: bit3 = write_error : Asserted if write request and FIFO is full bit2 = write_full : FIFO is FULL bit1 = read_error : Asserted if read request with empty FIFO bit0 = read_empty : FIFO is empty	0000

**Table 138. Register Name: config107 – Address: 0x6B, Default: 0x0000**

Register Name	Addr (Hex)	Bit	Name	Function	Default Value
config107 WRITE TO CLEAR	0x6B	15:8	alarm_lane_error(7)	Lane7 errors: bit15 = multiframe alignment error bit14 = frame alignment error bit13 = link configuration error bit12 = elastic buffer overflow (bad RBD value) bit11 = elastic buffer match error. The first non-/K/ doesn't match "match_ctrl" and "match_data" programmed values. bit10 = code synchronization error bit9 = 8b/10b not-in-table code error bit8 = 8b/10b disparity error	0x00
		7:4	reserved	Reserved	0000
		3:0	alarm_fifo_flags(0)	Lane0 FIFO errors: bit3 = write_error : Asserted if write request and FIFO is full bit2 = write_full : FIFO is FULL bit1 = read_error : Asserted if read request with empty FIFO bit0 = read_empty : FIFO is empty	0000

**Table 139. Register Name: config108 – Address: 0x6C, Default: 0x0000**

Register Name	Addr (Hex)	Bit	Name	Function	Default Value
config108 WRITE TO CLEAR	0x6C	15:12	alarm_sysref_err	SYSREF Errors discovered for each lane. bit15 = lane3 bit14 = lane2 bit13 = lane1 bit12 = lane0	0000
		11:8	alarm_pap	Alarms from the PAP blocks bit11 = data path D bit10 = data path C bit9 = data path B bit8 = data path A While any alarm_pap is asserted the attenuation for the appropriate data path is applied.	0000
		7:4	reserved	Reserved	0000
		3	alarm_rw0_pll	Driven high if the PLL in the SerDes block0 goes out of lock. A false alarm is generated at startup when the PLL is locking. User will have to reset this bit after start to monitor accurately.	0
		2	alarm_rw1_pll	Driven high if the PLL in the SerDes block1 goes out of lock. A false alarm is generated at startup when the PLL is locking. User will have to reset this bit after start to monitor accurately.	0
		1	reserved	Reserved	0
		0	alarm_from_pll	When this bit is a '1' the DAC PLL is out of lock.	0

**Table 140. Register Name: config109 – Address: 0x6D, Default: 0x00xx**

Register Name	Addr (Hex)	Bit	Name	Function	Default Value
config109	0x6D	15:8	alarm_from_shorttest	These are the alarms from the different lanes during JESD short test checking. bit15 = lane7 alarm bit14 = lane6 alarm bit13 = lane5 alarm bit12 = lane4 alarm bit11 = lane3 alarm bit10 = lane2 alarm bit9 = lane1 alarm bit8 = lane0 alarm	0x00
		7:0	memin_rw_losdct	These are the loss of signal detect outputs from the SERDES lanes: bit7 = lane7 loss off signal bit6 = lane6 loss off signal bit5 = lane5 loss off signal bit4 = lane4 loss off signal bit3 = lane3 loss off signal bit2 = lane2 loss off signal bit1 = lane1 loss off signal bit0 = lane0 loss off signal	No default

**Table 141. Register Name: config110 – Address: 0x6E, Default: 0x0000**

Register Name	Addr (Hex)	Bit	Name	Function	Default Value
config110	0x6E	15:14	sfrac_coef0_ab	Small delay fractional filter tap0: Valid values [-2 to 1]	00
		13:9	sfrac_coef1_ab	Small delay fractional filter tap1: Valid values [-16 to 15]	00000
		8:1	sfrac_coef2_ab	Small delay fractional filter tap2: Valid values [-128 127]	00000000
		0	reserved	Reserved	0

**Table 142. Register Name: config111 – Address: 0x6F, Default: 0x0000**

Register Name	Addr (Hex)	Bit	Name	Function	Default Value
config111	0x6F	15:10	reserved	Reserved	000000
		9:0	sfrac_coef3_ab	Small delay fractional filter tap3: Valid values [-512 to 511]	0000000000

**Table 143. Register Name: config112 – Address: 0x70, Default: 0x0000**

Register Name	Addr (Hex)	Bit	Name	Function	Default Value
config112	0x70	15:0	sfrac_coef4_ab(15:0)	Small delay fractional filter tap4: Valid values [-262144 to 262143]	0x0000

**Table 144. Register Name: config113 – Address: 0x71, Default: 0x0000**

Register Name	Addr (Hex)	Bit	Name	Function	Default Value
config113	0x71	15:13	sfrac_coef4_ab(18:16)	Upper bits of small delay fraction filter tap4.	000
		12:10	reserved	Reserved	000
		9:0	sfrac_coef5_ab	Small delay fractional filter tap5: Valid values [-512 to 511]	0000000000

**Table 145. Register Name: config114 – Address: 0x72, Default: 0x0000**

Register Name	Addr (Hex)	Bit	Name	Function	Default Value
config114	0x72	15:9	reserved	Reserved	00000000
		8:0	sfrac_coef6_ab	Small delay fractional filter tap6: Valid values [-256 to 255]	0000000000

**Table 146. Register Name: config115 – Address: 0x73, Default: 0x0000**

Register Name	Addr (Hex)	Bit	Name	Function	Default Value
config115	0x73	15:9	sfrac_coef7_ab	Small delay fractional filter tap7: Valid values [-64 to 63]	00000000
		8:4	sfrac_coef8_ab	Small delay fractional filter tap8: Valid values [-16 to 15]	000000
		3:2	sfrac_coef9_ab	Small delay fractional filter tap9: Valid values [-2 to 1]	00
		1:0	Not Used	Not Used	00

**Table 147. Register Name: config116 – Address: 0x74, Default: 0x0000**

Register Name	Addr (Hex)	Bit	Name	Function	Default Value
config116	0x74	15:0	sfrac_invgain_ab(15:0)	Controls the divide amount in the small fractional delay gain computation: Valid values [-524288 to 524284]	0x0000

**Table 148. Register Name: config117 – Address: 0x75, Default: 0x0000**

Register Name	Addr (Hex)	Bit	Name	Function	Default Value
config117	0x75	15:12	sfrac_invgain_ab(19:16)	Upper bits of the small fraction delay FIR gain value.	0000
		11:3	reserved	Reserved	0000000000
		5:3	lfrac_coefssel_a	Selected that coefficients used for the A data path FIR5B or large fractional delay FIR.	000
		2:0	lfrac_coefssel_b	Selected that coefficients used for the B data path FIR5B or large fractional delay FIR.	000

**Table 149. Register Name: config118 – Address: 0x76, Default: 0x0000**

Register Name	Addr (Hex)	Bit	Name	Function	Default Value
config118	0x76	15:14	sfrac_coef0_cd	Small delay fractional filter tap0: Valid values [–2 to 1]	00
		13:9	sfrac_coef1_cd	Small delay fractional filter tap1: Valid values [–16 to 15]	00000
		8:1	sfrac_coef2_cd	Small delay fractional filter tap2: Valid values [–128 127]	00000000
		0	reserved	Reserved	0

**Table 150. Register Name: config119 – Address: 0x77, Default: 0x0000**

Register Name	Addr (Hex)	Bit	Name	Function	Default Value
config119	0x77	15:10	reserved	Reserved	000000
		9:0	sfrac_coef3_cd	Small delay fractional filter tap3: Valid values [–512 to 511]	0000000000

**Table 151. Register Name: config120 – Address: 0x78, Default: 0x0000**

Register Name	Addr (Hex)	Bit	Name	Function	Default Value
config120	0x78	15:0	sfrac_coef4_cd(15:0)	Small delay fractional filter tap4: Valid values [–262144 to 262143]	0x0000

**Table 152. Register Name: config121 – Address: 0x79, Default: 0x0000**

Register Name	Addr (Hex)	Bit	Name	Function	Default Value
config121	0x79	15:13	sfrac_coef4_cd(18:16)	Upper bits of small delay fraction filter tap4.	000
		12:10	reserved	Reserved	000
		9:0	sfrac_coef5_cd	Small delay fractional filter tap5: Valid values [–512 to 511]	0000000000

**Table 153. Register Name: config122 – Address: 0x7A, Default: 0x0000**

Register Name	Addr (Hex)	Bit	Name	Function	Default Value
config122	0x7A	15:9	reserved	Reserved	0000000
		8:0	sfrac_coef6_cd	Small delay fractional filter tap6: Valid values [–256 to 255]	

**Table 154. Register Name: config123 – Address: 0x7B, Default: 0x0000**

Register Name	Addr (Hex)	Bit	Name	Function	Default Value
config123	0x7B	15:9	sfrac_coef7_cd	Small delay fractional filter tap7: Valid values [–64 to 63]	0000000
		8:4	sfrac_coef8_cd	Small delay fractional filter tap8: Valid values [–16 to 15]	00000
		3:2	sfrac_coef9_cd	Small delay fractional filter tap9: Valid values [–2 to 1]	00
		1:0	Not Used	Not Used	00

**Table 155. Register Name: config124 – Address: 0x7C, Default: 0x0000**

Register Name	Addr (Hex)	Bit	Name	Function	Default Value
config124	0x7C	15:0	sfrac_invgain_cd(15:0)	Controls the divide amount in the small fractional delay gain computation: Valid values [–524288 to 524284]	0x0000

**Table 156. Register Name: config125 – Address: 0x7D, Default: 0x0000**

Register Name	Addr (Hex)	Bit	Name	Function	Default Value
config125	0x7D	15:12	sfrac_invgain_cd(19:16)	Upper bits of the small fraction delay FIR gain value.	0000
		11:6	reserved	Reserved	000000000
		5:3	lfrac_coefssel_c	Selected that coefficients used for the C data path FIR5B or large fractional delay FIR.	000
		2:0	lfrac_coefssel_d	Selected that coefficients used for the D data path FIR5B or large fractional delay FIR.	000

**Table 157. Register Name: config126 – Address: 0x7E, Default: 0x0000**

Register Name	Addr (Hex)	Bit	Name	Function	Default Value
config126	0x7E	15:12	reserved	Reserved	0000
		11:8	reserved	Reserved	0000
		7:4	reserved	Reserved	0000
		3:0	reserved	Reserved	0000

**Table 158. Register Name: config127 – Address: 0x7F, Default: 0x0009**

Register Name	Addr (Hex)	Bit	Name	Function	Default Value
config127 READ ONLY/No RESET Value	0x7F	15	memin_efc_autoload_done	Goes high when the autoload from the fusefarm is done.	0
		14:10	memin_efc_error	Resulting error code from last Fusefarm instruction	00000
		9:8	not used	Not Used	00
		7:5	not used	Not Used	000
		4:3	vendorid	This is the vendor ID. It shouldn't change but will have access to change through a hardwire connection outside the DIG block.	01
		2:0	versionid	A hardwired register that contains the version of the chip. This value is accessible outside the DIG block for changing.	001

## 8 Applications and Implementation

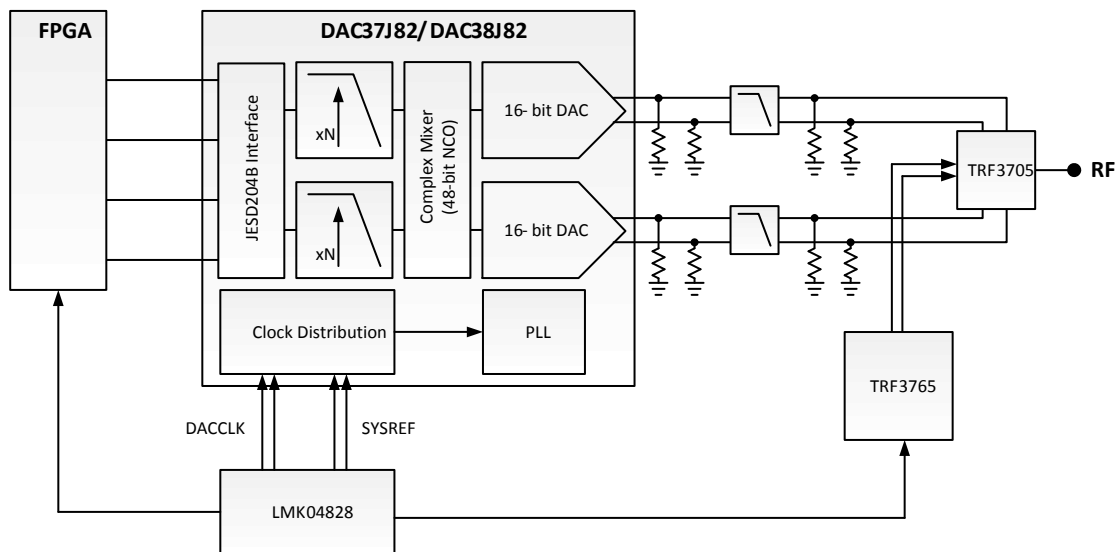
### 8.1 Application Information

The DAC37J82/DAC38J82 family is a 16-bit DAC with max input data rate up to 1.23GSPS per DAC. It provides one transmit paths with up to 1GHz complex information bandwidth. The DAC37J82/DAC38J82 consumes about 0.9W at 1.6GSPS and 1.1W at 2.5GSPS. The digital Quadrature Modulator Correction and Group Delay Correction enable complete IQ compensation for gain, offset, phase, and group delay between channels in direct up-conversion applications. The DAC37J82 and DAC38J82 provide the bandwidth, performance, small footprint and low power consumption needed for multi-mode 2G/3G/4G cellular base stations to migrate to more advanced technologies, such as LTE-Advanced and carrier aggregation on multiple antennas.

### 8.2 Typical Applications

#### 8.2.1 Low-IF Wideband LTE Transmitter

Figure 81 shows an example block diagram for a direct conversion radio. Here it has been assumed that the desired output bandwidth is 80-MHz which could be, for instance, four 20-MHz LTE signals. It is also assumed that digital pre-distortion (DPD) is used to correct 3rd order distortion so the total DAC output bandwidth is 240 MHz. Interpolation is used to output the signal at the highest sampling rate possible to simplify the analog filtering requirements and move high order harmonics out of band. The internal PLL is used to generate the final DAC output clock from a reference clock of 307.2 MHz. The complex mixer will be used to place the baseband input signal at a desired intermediate frequency (IF). The maximum serdes rate that the chosen FPGA supports is 12.5 Gbps and the minimum number of serdes lanes is desired.



**Figure 81. Low-IF Wideband LTE Transmitter Diagram**

## Typical Applications (continued)

### 8.2.1.1 Design Requirements

For this design example, use the parameters listed in the table below as the input parameters.

DESIGN PARAMETER	EXAMPLE VALUE
Signal Bandwidth ( $BW_{\text{signal}}$ )	80 MHz
Total DAC Output Bandwidth ( $BW_{\text{total}}$ )	240 MHz
DAC PLL	On
DAC PLL Reference Frequency	307.2 MHz
Maximum FPGA Serdes Data Rate	12.5 Gbps

### 8.2.1.2 Detailed Design Procedure

#### 8.2.1.2.1 Data Input Rate

Nyquist theory says that the data rate must be at least two times the highest signal frequency. The data will be sent to the DAC as complex baseband data. For 240 MHz of signal bandwidth only 120 MHz of input bandwidth is needed, setting the minimum data input rate as 240 MSPS. Further, the process of interpolation requires low pass filters that limit the useable input bandwidth to about 40 percent of  $F_{\text{data}}$ . Therefore, the minimum data input rate is 300 MSPS. The standard telecom data rate of 307.2 MSPS is chosen.

#### 8.2.1.2.2 Intermediate Frequency

The intermediate frequency is chosen to keep low order harmonics out of band while staying low enough to not degrade the ACPR performance. The band of interest is 240 MHz wide, while the signal bandwidth is 80 MHz wide. The lowest frequency that the second harmonic of the signal will fall at is given on the left side of the inequality shown below based on the chosen IF center frequency. The highest frequency in the band of interest (Total DAC Output Bandwidth) is the right side of the inequality. Solving the inequality for IF and choosing a center frequency higher than that will keep the second harmonic out of the bandwidth of interest.

$$(IF - BW_{\text{signal}} / 2) * 2 \geq IF + BW_{\text{total}} / 2 \quad (3)$$

The lowest IF that satisfies the inequality is shown below.

$$IF \geq BW_{\text{signal}} + BW_{\text{total}} / 2 \quad (4)$$

So for a signal bandwidth of 80 MHz and a total bandwidth of 240 MHz, the lowest IF that satisfies the inequality is 200 MHz. Choose 220 MHz to move HD2 slightly away from the band. The full complex mixer can be enabled with the NCO frequency chosen as 220 MHz to realize this IF frequency.

#### 8.2.1.2.3 Interpolation

It is desired to use the highest DAC output rate as possible to move the DAC images further from the signal of interest to ease the analog filter requirements. The DAC output rate must be greater than two times the highest output frequency, in this case  $2 * (220 \text{ MHz} + BW_{\text{total}} / 2) = 680 \text{ MHz}$ . The table below shows the possible DAC output rates based on the data input rate and available interpolation settings. The DAC image frequency is also listed. Based on the result, 8x interpolation will push the image frequency 1777.6 MHz away from the band of interest, so the DAC output rate is chosen as 2457.6 MSPS.

Although not shown the high output rate also pushes higher order harmonics out of the band of interest that would have aliased back in at 1228.8 MSPS.

INTERPOLATION	DAC OUTPUT RATE	POSSIBLE?	LOWEST IMAGE FREQUENCY	DISTANCE FROM BAND OF INTEREST
1	307.2 MSPS	No	N/A	N/A
2	614.4 MSPS	No	N/A	N/A
4	1228.8 MSPS	Yes	888.8 MHz	548.8 MHz
8	2457.6 MSPS	Yes	2117.6 MHz	1777.6 MHz
16	4915.2 MSPS	No	N/A	N/A

### 8.2.1.2.4 DAC PLL Setup

The reference frequency from an onboard clock chip, like the LMK04828, is 307.2 MHz. It is desired to use the highest PFD update rate to maintain the best phase noise performance, but not too high to avoid spurs, therefore the N Divider is chosen to be 2 for a PFD frequency of 153.6 MHz. In order to have the feedback side of the PFD be equal to the reference side (153.6 MHz) and create a DACCLK rate of 2457.6 MHz, the M Divider must be set to 16. Using Table 29, it is found that a VCO frequency of 4915.2 MHz can be used to generate a DACCLK frequency of 2457.6 MHz, so the Prescaler is set to 2 and the H-band VCO is selected.

### 8.2.1.2.5 Serdes Lanes

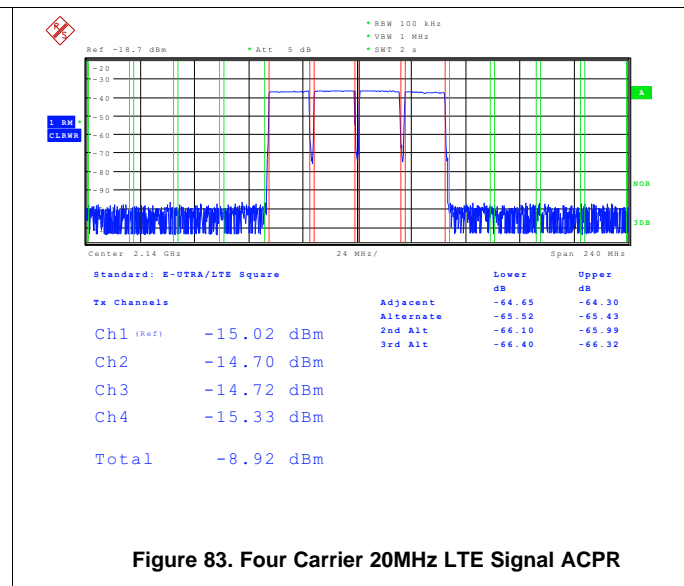
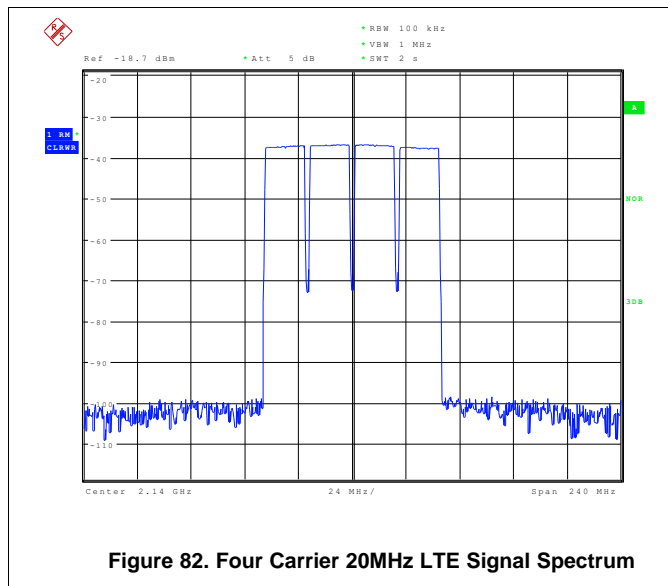
It is desired to use the minimum number of serdes lanes while staying under the maximum serdes line rate possible with the chosen FPGA. In the design requirements, the FPGA maximum serdes data rate was given as 12.5 Gbps. For the chosen input data rate of 307.2 MSPS and with 8b/10b encoding on the serdes lanes, each DAC requires a serialized data rate of 6144 Mbps, as given by the equation below.

$$\text{Serialized Data Rate} = F_{\text{data}} * 16 * (10 / 8) \tag{5}$$

The total serialized data rate with a dual DAC is 6144 Mbps \* 2 = 12.288 Gbps. This total serialized data rate is split among the total number of lanes. The table below shows the line rate versus the total number of lanes. One lanes running at 12.288 Gbps is chosen since the minimum number of lanes is desired. This sets the JESD204B mode (LMF) for the DAC as 124 mode.

NUMBER OF LANES	LINE RATE	POSSIBLE?
1	12.288 Gbps	Yes
2	6.144 Gbps	Yes
4	3.072 Gbps	Yes
8	1.536 Gbps	Yes

### 8.2.1.3 Application Performance Plots





### 8.2.2 Zero-IF Wideband Transmitter

The block diagram shown in Figure 84 also applies for a zero-IF wideband transmitter. However in this case the signal bandwidth is 192 MHz and digital predistortion is used to correct third and fifth order distortion, meaning the total bandwidth of interest is 960 MHz. Interpolation is used to output the signal at the highest sampling rate possible to simplify the analog filtering requirements. The DAC sample clock is provided directly from a clock chip, such as TI's LMK04828. The maximum serdes rate that the chosen FPGA supports is 12.5 Gbps and the minimum number of serdes lanes is desired.

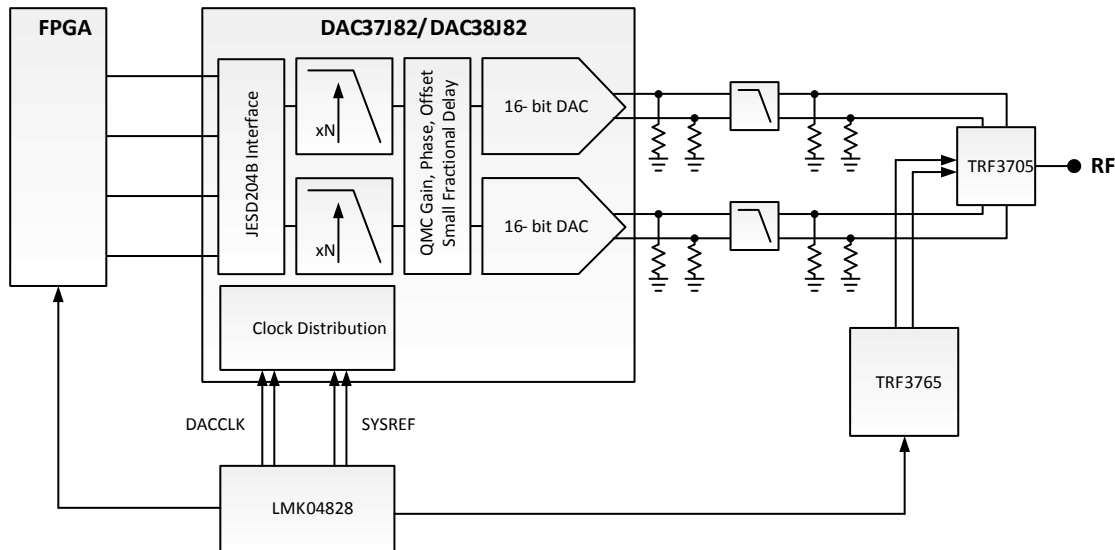


Figure 84. Zero-IF Wideband Transmitter Diagram

#### 8.2.2.1 Design Requirements

For this design example, use the parameters listed in the table below as the input parameters.

DESIGN PARAMETER	EXAMPLE VALUE
Signal Bandwidth ( $BW_{\text{signal}}$ )	192 MHz
Total DAC Output Bandwidth ( $BW_{\text{total}}$ )	960 MHz
DAC PLL	Off
Maximum FPGA Serdes Data Rate	12.5 Gbps

#### 8.2.2.2 Detailed Design Procedure

##### 8.2.2.2.1 Data Input Rate

In this application the total complex bandwidth is 960 MHz meaning that at least 480 MHz of real bandwidth is needed, setting the minimum data input rate at 960 MSPS. However, the process of interpolation requires digital low pass filters that limit the useable input bandwidth to about 40 percent of  $F_{\text{data}}$ . Therefore, the minimum data input rate is 1.2 GSPS.

##### 8.2.2.2.2 Interpolation

It is desired to use the highest DAC output rate as possible to move the DAC images further from the signal of interest to ease the analog filter requirements. The DAC output rate must be greater than two times the highest output frequency, in this case  $2 * 960 \text{ MHz} / 2 = 960 \text{ MHz}$ . The table below shows the possible DAC output rates based on the data input rate and available interpolation settings. The DAC image frequency is also listed. Based on the result, 2x interpolation is chosen which will push the image frequency 1.44 GHz away from the band of interest.

INTERPOLATION	DAC OUTPUT RATE	POSSIBLE?	LOWEST IMAGE FREQUENCY	DISTANCE FROM BAND OF INTEREST
1	1.2 GSPS	Yes	720 MHz	240 MHz
2	2.4 GSPS	Yes	1920 MHz	1440 MHz
4	4.8 GSPS	No	N/A	N/A
8	9.6 GSPS	No	N/A	N/A
16	19.2 GSPS	No	N/A	N/A

### 8.2.2.2.3 Serdes Lanes

It is desired to use the minimum number of serdes lanes while staying under the maximum serdes line rate possible with the chosen FPGA. In the design requirements, the FPGA maximum serdes data rate was given as 12.5 Gbps. For the chosen input data rate of 1.2 GSPS and with 8b/10b encoding on the serdes lanes, each DAC requires a serialized data rate of 24 Gbps, as given by the equation below.

$$\text{Serialized Data Rate} = F_{\text{data}} * 16 * (10 / 8) \quad (6)$$

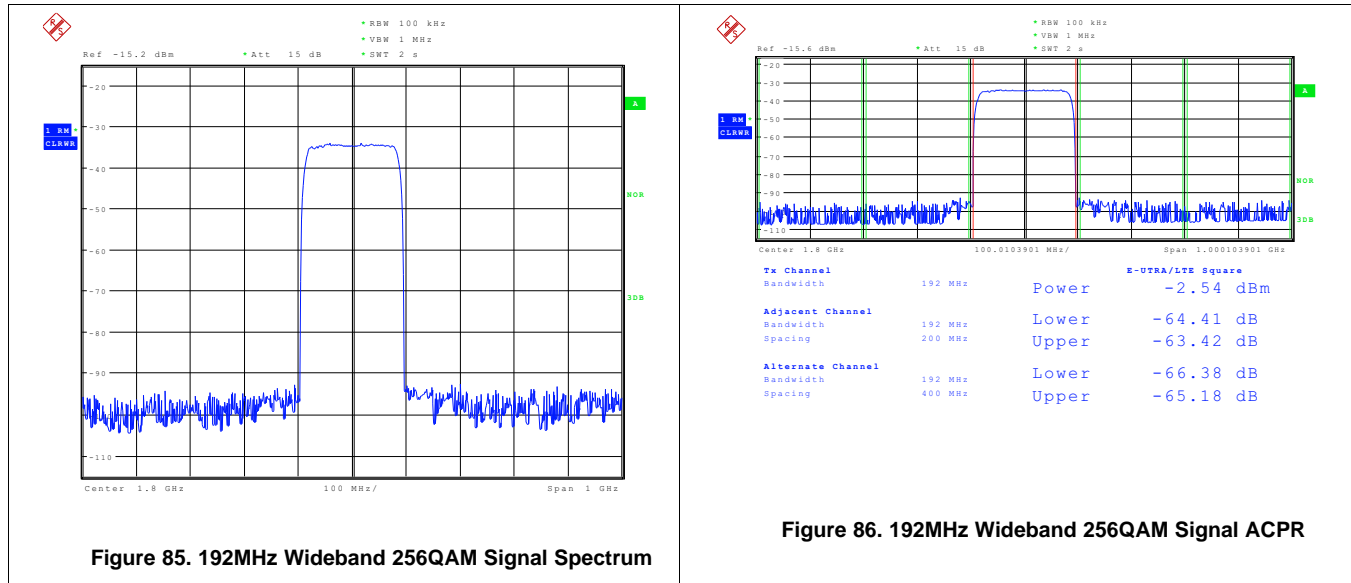
The total serialized data rate with a quad DAC is 24 Gbps \* 2 = 48 Gbps. This total serialized data rate is split among the total number of lanes. The table below shows the line rate versus the total number of lanes. Four lanes must be chosen to support this data rate. This sets the JESD204B mode (LMF) for the DAC as 421 mode.

NUMBER OF LANES	LINE RATE	POSSIBLE?
1	48 Gbps	No
2	24 Gbps	No
4	12 Gbps	Yes
8	6 Gbps	Yes

### 8.2.2.2.4 LO Feedthrough and Sideband Correction

Although the I/Q modulation process will inherently reduce the level of the RF sideband signal, a zero-IF system will likely need additional sideband suppression to maximize performance. Further, any mixing process will result in some feedthrough of the LO source. The DAC37J82 and DAC38J82 contain digital features to cancel both the LO feedthrough and sideband signal. The LO feedthrough is corrected by adding a DC offset to the DAC outputs until the LO feedthrough is suppressed. The sideband suppression can be improved by correcting gain, phase, and group delay differences between the I and Q analog outputs. The phase and gain adjustments are made using the QMC block of the DAC while the group delay adjustments are done using the small fractional delay filter. First the phase should be adjusted to suppress the sideband signal at low DAC output frequencies due to phase error. Then the gain can be adjusted to further improve the suppression. Finally, the small fractional filter can be used to improve the sideband suppression across the rest of the signal bandwidth.

### 8.2.2.3 Application Performance Plots



## 8.3 Initialization Set Up

The following start up sequence is recommended to power up the DAC38J82/DAC37J82 family.

1. Set TXENABLE low.
2. Supply all 0.9-V supplies (VDDDIG09, VDDT09, VDDDAC09, VDDCLK09), all 1.8-V supplies (VDDR18, VDDS18, VQPS18, VDDIO18, VDDAPLL18, VDDAREF18), and all 3.3-V supplies (VDDADAC33). The supplies can be powered up simultaneously or in any order. There are no specific requirements on the ramp rate for the supplies.
3. RESET the JTAG port by either toggling TRSTB low if using the JTAG port or holding TRSTB low if not using JTAG.
4. Start the DACCLK generation.
5. Toggle RESETB low to reset the SIF registers.
6. Program the DAC PLL settings (*config26*, *config49*, *config50*, *config51*). If the PLL is not used, set *pll\_sleep* and *pll\_reset* to “1” and *pll\_ena* to “0”.
7. Program the SERDES settings (*config61*, *config62*) including the *serdes\_clk\_sel* and *serdes\_refclk\_div*.
8. Program the SERDES lane settings (*config63*, *config71*, *config73*, *config74*, *config96*).
9. Program *clkjesd\_div*, *drvser\_sysref\_mode*, and *interp*.
10. Program the JESD settings (*config3*, *config74-77*, *config79*, *config80-85*, *config92*, *config97*).
11. Program the DIG block settings (NCO, PA protection, QMC, fractional delay, etc.) and set the preferred SYNC modes for the digital blocks (*config30-32*).
12. Verify the SERDES PLL lock status by checking the SERDES PLL alarms: *alarm\_rw0\_pll* (alarm for lanes 0 through 3) and *alarm\_rw1\_pll* (alarm for lanes 4 through 7).
13. Set *init\_state* to “0000” and *jesd\_reset\_n* to “1” to start the JESD204B link initialization.
14. Start the SYSREF generation.
15. Enable transmission of data by asserting the TXENABLE pin or setting *sif\_txenable* to “1”.
16. Clear the alarms, then wait approximately 1-2µs and check values.
17. Verify that DAC output is the desired output.

## 9 Power Supply Recommendations

The DAC37J82 and DAC38J82 use three different power supply voltages. Some of the DAC power supplies are noise sensitive. The table below is a summary of the various power supply of the DAC. Care should be taken to keep clean power supplies routing away from noisy digital supplies. It is recommended to use at least two power layers. Avoid placing digital supplies and clean supplies on adjacent board layers and use a ground layer between noisy and clean supplies if possible. All supplies pins should be decoupled as close to the pins as possible using small value capacitors, with larger bulk capacitors placed further away.

POWER SUPPLY	VOLTAGE	NOISE SENSITIVE?	RECOMMENDATION
VDDADAC33	3.3 V	Yes	Provide clean voltage, avoid spurious noise
VDDAPLL18	1.8 V	Yes	Provide clean voltage, avoid spurious noise
VDDAREF18	1.8 V	Yes	Provide clean voltage, avoid spurious noise
VDDCLK09	0.9 V	Yes	Provide clean voltage, avoid spurious noise
VDDDAC09	0.9 V	Yes	Provide clean voltage, avoid spurious noise
VDDDIG09	0.9 V	No	Digital supply, keep separated from noise sensitive 0.9 V supplies.
VDDIO18	1.8 V	No	No concern
VDDR18	1.8 V	Yes	Provide clean voltage
VDDS18	1.8 V	No	No concern
VDDT09	0.9 V	Yes	Provide clean voltage
VQPS18	1.8 V	No	No concern

## 10 Layout

### 10.1 Layout Guidelines

- DAC output termination resistors should be placed as close to the output pins as possible to provide a DC path to ground and set the source impedance.
- For PLL mode, if the external loop filter is not used then leave the pin floating without any board routing. Signals coupling to this node may cause clock mixing spurs in the DAC output.
- Route the high speed serdes lanes as impedance-controlled, tightly-coupled, differential traces.
- Maintain a solid ground plane under the serdes lanes without any ground plane splits.
- AC couple the serdes lines between the logic device and the DAC using 0201 size capacitors that maintain low impedance at the serialized data rate.
- Simulation of the serdes channel is recommended to verify JESD204B standard compliance to ensure compatibility between devices.
- Keep the SYSREF routing away from the DACCLK routing to reduce coupling. Using a pulsed SYSREF or disabling a continuous SYSREF is recommended during normal operation to avoid spurs in the output spectrum.
- Keep routing for RBIAS short, for instance a resistor can be placed on the bottom of the board directly connecting the RBIAS ball to a GND ball.
- Decoupling capacitors should be placed as close to the supply pins as possible, for instance a capacitor can be placed on the bottom of the board directly connecting the supply ball to a GND ball.
- Noisy power supplies should be routed away from clean supplies. Use two power plane layers, preferably with a GND layer in between.

10.2 Layout Examples

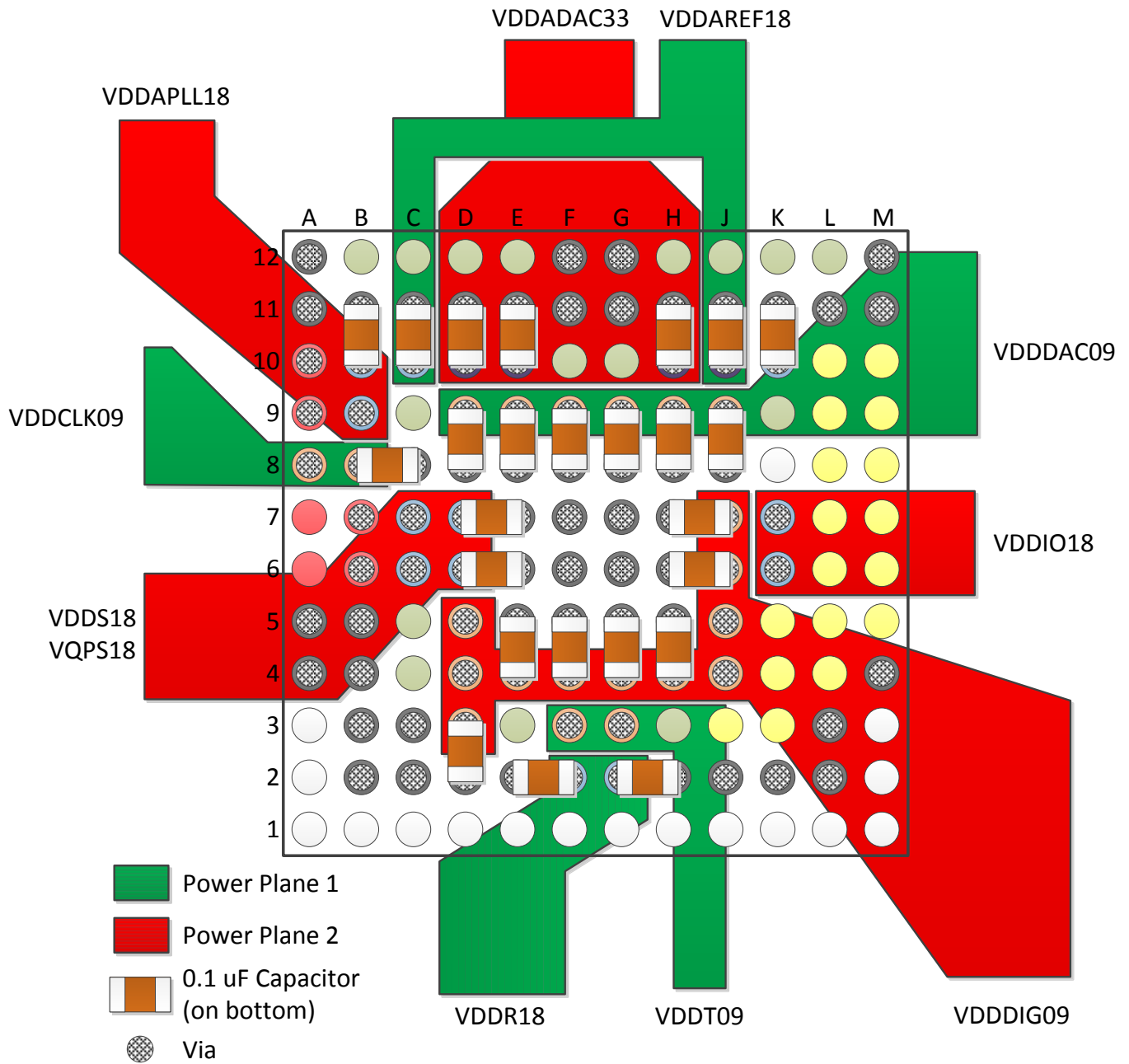


Figure 87. DAC37J82/DAC38J82 Layout for Power Supplies

Layout Examples (continued)

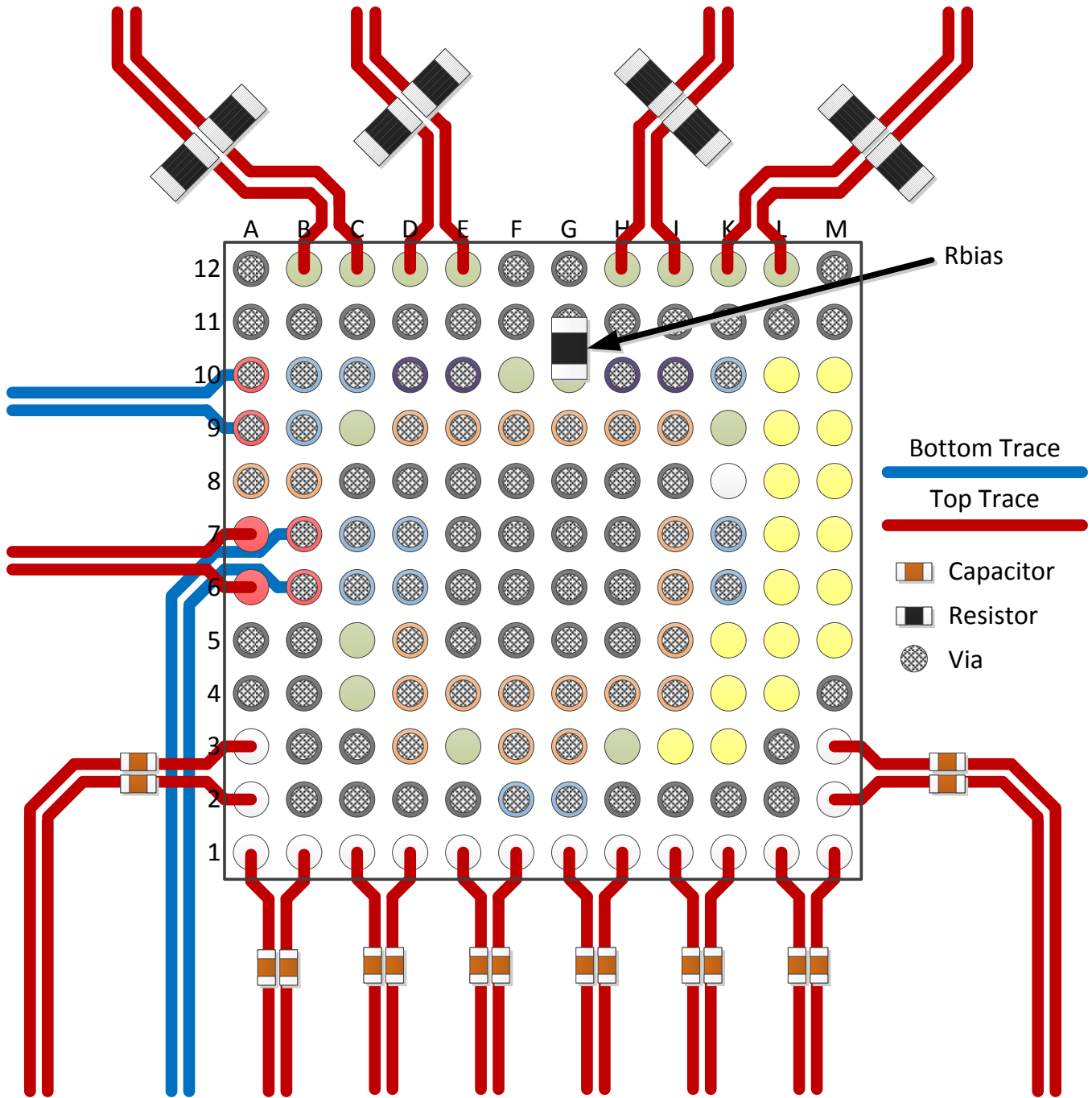


Figure 88. DAC37J82/DAC38J82 Layout for Signals

## 11 器件和文档支持

### 11.1 相关链接

以下表格列出了快速访问链接。范围包括技术文档、支持与社区资源、工具和软件，并且可以快速访问样片或购买链接。

**Table 159. 相关链接**

部件	产品文件夹	样片与购买	技术文档	工具与软件	支持与社区
DAC37J82	<a href="#">请单击此处</a>	<a href="#">请单击此处</a>	<a href="#">请单击此处</a>	<a href="#">请单击此处</a>	<a href="#">请单击此处</a>
DAC38J82	<a href="#">请单击此处</a>	<a href="#">请单击此处</a>	<a href="#">请单击此处</a>	<a href="#">请单击此处</a>	<a href="#">请单击此处</a>

### 11.2 Trademarks

All trademarks are the property of their respective owners.

### 11.3 Electrostatic Discharge Caution



These devices have limited built-in ESD protection. The leads should be shorted together or the device placed in conductive foam during storage or handling to prevent electrostatic damage to the MOS gates.

### 11.4 术语表

[SLYZ022](#) — TI 术语表。

这份术语表列出并解释术语、首字母缩略词和定义。



## 12 机械封装和可订购信息

以下页中包括机械封装和可订购信息。 这些信息是针对指定器件可提供的最新数据。 这些数据会在无通知且不对本文档进行修订的情况下发生改变。 欲获得该数据表的浏览器版本，请查阅左侧的导航栏。

**PACKAGING INFORMATION**

Orderable Device	Status (1)	Package Type	Package Drawing	Pins	Package Qty	Eco Plan (2)	Lead finish/ Ball material (6)	MSL Peak Temp (3)	Op Temp (°C)	Device Marking (4/5)	Samples
DAC37J82IAAV	ACTIVE	FCCSP	AAV	144	168	RoHS & Green	SNAGCU	Level-3-260C-168 HR	-40 to 85	DAC37J82I	<a href="#">Samples</a>
DAC37J82IAAVR	ACTIVE	FCCSP	AAV	144	1000	RoHS & Green	SNAGCU	Level-3-260C-168 HR	-40 to 85	DAC37J82I	<a href="#">Samples</a>
DAC38J82IAAV	ACTIVE	FCCSP	AAV	144	168	RoHS & Green	SNAGCU	Level-3-260C-168 HR	-40 to 85	DAC38J82I	<a href="#">Samples</a>
DAC38J82IAAVR	ACTIVE	FCCSP	AAV	144	1000	RoHS & Green	SNAGCU	Level-3-260C-168 HR	-40 to 85	DAC38J82I	<a href="#">Samples</a>

(1) The marketing status values are defined as follows:

**ACTIVE:** Product device recommended for new designs.

**LIFEBUY:** TI has announced that the device will be discontinued, and a lifetime-buy period is in effect.

**NRND:** Not recommended for new designs. Device is in production to support existing customers, but TI does not recommend using this part in a new design.

**PREVIEW:** Device has been announced but is not in production. Samples may or may not be available.

**OBSOLETE:** TI has discontinued the production of the device.

(2) **RoHS:** TI defines "RoHS" to mean semiconductor products that are compliant with the current EU RoHS requirements for all 10 RoHS substances, including the requirement that RoHS substance do not exceed 0.1% by weight in homogeneous materials. Where designed to be soldered at high temperatures, "RoHS" products are suitable for use in specified lead-free processes. TI may reference these types of products as "Pb-Free".

**RoHS Exempt:** TI defines "RoHS Exempt" to mean products that contain lead but are compliant with EU RoHS pursuant to a specific EU RoHS exemption.

**Green:** TI defines "Green" to mean the content of Chlorine (Cl) and Bromine (Br) based flame retardants meet JS709B low halogen requirements of <=1000ppm threshold. Antimony trioxide based flame retardants must also meet the <=1000ppm threshold requirement.

(3) MSL, Peak Temp. - The Moisture Sensitivity Level rating according to the JEDEC industry standard classifications, and peak solder temperature.

(4) There may be additional marking, which relates to the logo, the lot trace code information, or the environmental category on the device.

(5) Multiple Device Markings will be inside parentheses. Only one Device Marking contained in parentheses and separated by a "-" will appear on a device. If a line is indented then it is a continuation of the previous line and the two combined represent the entire Device Marking for that device.

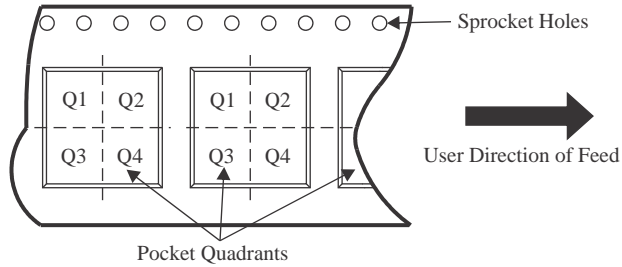
(6) Lead finish/Ball material - Orderable Devices may have multiple material finish options. Finish options are separated by a vertical ruled line. Lead finish/Ball material values may wrap to two lines if the finish value exceeds the maximum column width.

**Important Information and Disclaimer:**The information provided on this page represents TI's knowledge and belief as of the date that it is provided. TI bases its knowledge and belief on information provided by third parties, and makes no representation or warranty as to the accuracy of such information. Efforts are underway to better integrate information from third parties. TI has taken and

continues to take reasonable steps to provide representative and accurate information but may not have conducted destructive testing or chemical analysis on incoming materials and chemicals. TI and TI suppliers consider certain information to be proprietary, and thus CAS numbers and other limited information may not be available for release.

In no event shall TI's liability arising out of such information exceed the total purchase price of the TI part(s) at issue in this document sold by TI to Customer on an annual basis.

**TAPE AND REEL INFORMATION**

**QUADRANT ASSIGNMENTS FOR PIN 1 ORIENTATION IN TAPE**


\*All dimensions are nominal

Device	Package Type	Package Drawing	Pins	SPQ	Reel Diameter (mm)	Reel Width W1 (mm)	A0 (mm)	B0 (mm)	K0 (mm)	P1 (mm)	W (mm)	Pin1 Quadrant
DAC37J82IAAVR	FCCSP	AAV	144	1000	330.0	24.4	10.3	10.3	2.5	16.0	24.0	Q1
DAC38J82IAAVR	FCCSP	AAV	144	1000	330.0	24.4	10.3	10.3	2.5	16.0	24.0	Q1

**TAPE AND REEL BOX DIMENSIONS**


\*All dimensions are nominal

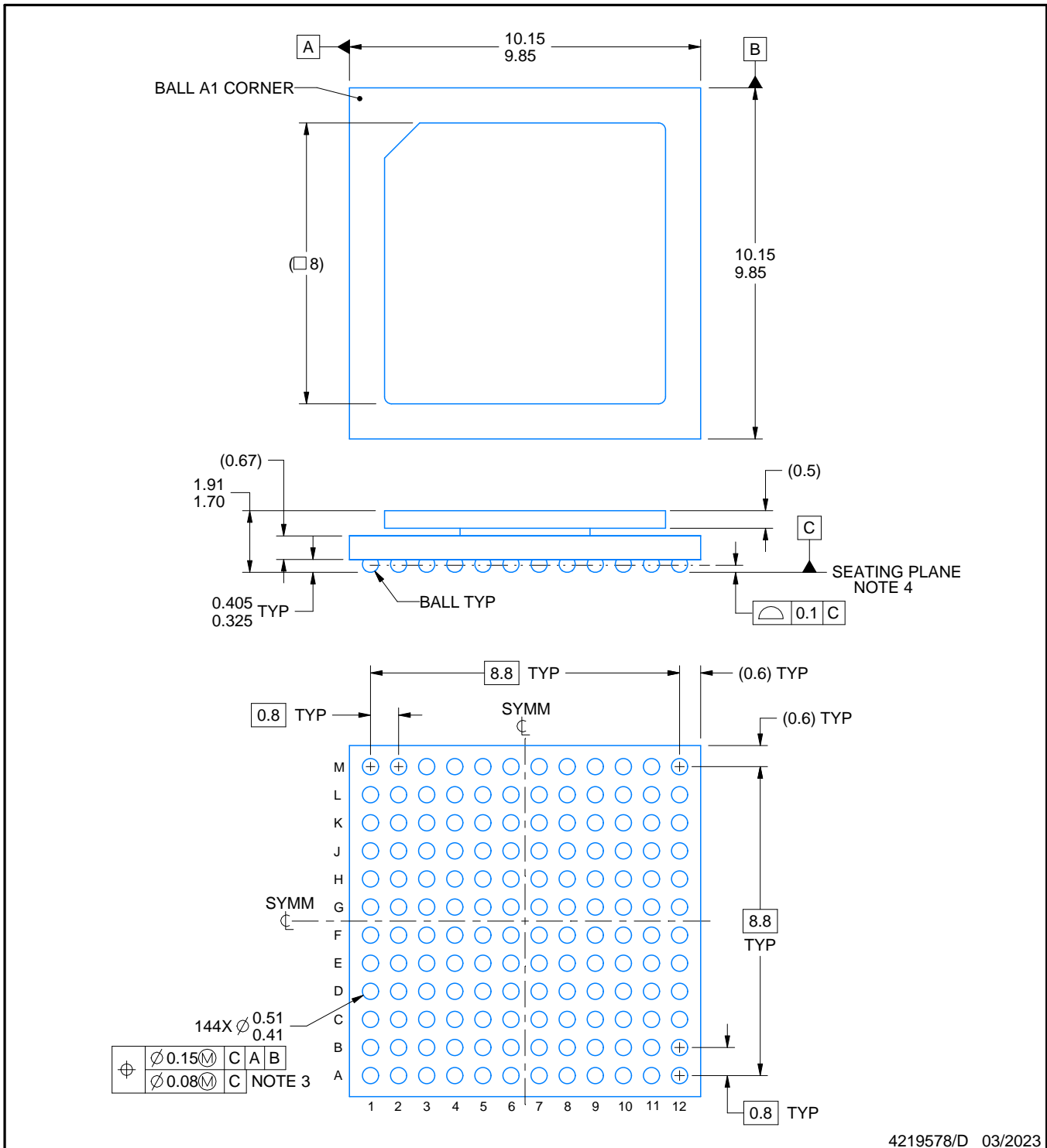
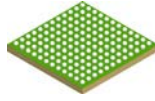
Device	Package Type	Package Drawing	Pins	SPQ	Length (mm)	Width (mm)	Height (mm)
DAC37J82IAAVR	FCCSP	AAV	144	1000	350.0	350.0	43.0
DAC38J82IAAVR	FCCSP	AAV	144	1000	350.0	350.0	43.0

**TRAY**


Chamfer on Tray corner indicates Pin 1 orientation of packed units.

\*All dimensions are nominal

Device	Package Name	Package Type	Pins	SPQ	Unit array matrix	Max temperature (°C)	L (mm)	W (mm)	K0 (µm)	P1 (mm)	CL (mm)	CW (mm)
DAC37J82IAAV	AAV	FCCSP	144	168	8 X 21	150	315	135.9	7620	14.65	11	11.95
DAC38J82IAAV	AAV	FCCSP	144	168	8 X 21	150	315	135.9	7620	14.65	11	11.95



## NOTES:

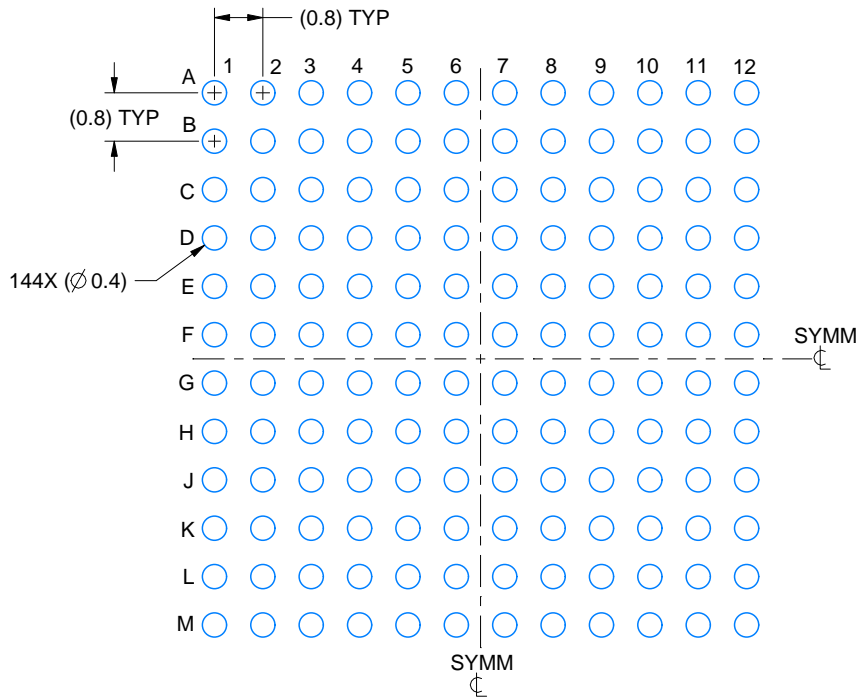
- All linear dimensions are in millimeters. Any dimensions in parenthesis are for reference only. Dimensioning and tolerancing per ASME Y14.5M.
- This drawing is subject to change without notice.
- Dimension is measured at the maximum solder ball diameter, parallel to primary datum C.
- Primary datum C and seating plane are defined by the spherical crowns of the solder balls.
- The lids are electrically floating (e.g. not tied to GND).

# EXAMPLE BOARD LAYOUT

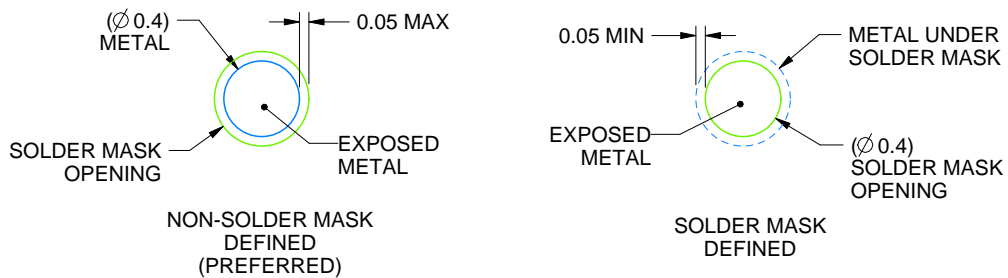
AAV0144A

FCBGA - 1.91 mm max height

BALL GRID ARRAY



LAND PATTERN EXAMPLE  
EXPOSED METAL SHOWN  
SCALE:8X



SOLDER MASK DETAILS  
NOT TO SCALE

4219578/D 03/2023

NOTES: (continued)

- Final dimensions may vary due to manufacturing tolerance considerations and also routing constraints. For more information, see Texas Instruments literature number SPRU811 ([www.ti.com/lit/spru811](http://www.ti.com/lit/spru811)).

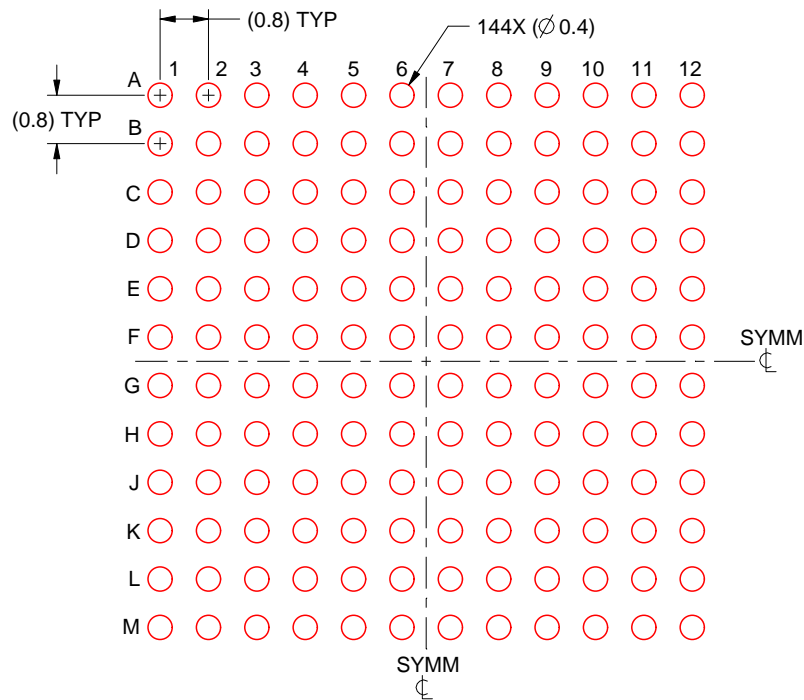


# EXAMPLE STENCIL DESIGN

AAV0144A

FCBGA - 1.91 mm max height

BALL GRID ARRAY



SOLDER PASTE EXAMPLE  
BASED ON 0.15 mm THICK STENCIL  
SCALE:8X

4219578/D 03/2023

NOTES: (continued)

7. Laser cutting apertures with trapezoidal walls and rounded corners may offer better paste release.

## 重要声明和免责声明

TI“按原样”提供技术和可靠性数据（包括数据表）、设计资源（包括参考设计）、应用或其他设计建议、网络工具、安全信息和其他资源，不保证没有瑕疵且不做任何明示或暗示的担保，包括但不限于对适销性、某特定用途方面的适用性或不侵犯任何第三方知识产权的暗示担保。

这些资源可供使用 TI 产品进行设计的熟练开发人员使用。您将自行承担以下全部责任：(1) 针对您的应用选择合适的 TI 产品，(2) 设计、验证并测试您的应用，(3) 确保您的应用满足相应标准以及任何其他功能安全、信息安全、监管或其他要求。

这些资源如有变更，恕不另行通知。TI 授权您仅可将这些资源用于研发本资源所述的 TI 产品的应用。严禁对这些资源进行其他复制或展示。您无权使用任何其他 TI 知识产权或任何第三方知识产权。您应全额赔偿因在这些资源的使用中对 TI 及其代表造成的任何索赔、损害、成本、损失和债务，TI 对此概不负责。

TI 提供的产品受 [TI 的销售条款](#) 或 [ti.com](#) 上其他适用条款/TI 产品随附的其他适用条款的约束。TI 提供这些资源并不会扩展或以其他方式更改 TI 针对 TI 产品发布的适用的担保或担保免责声明。

TI 反对并拒绝您可能提出的任何其他或不同的条款。

邮寄地址：Texas Instruments, Post Office Box 655303, Dallas, Texas 75265

Copyright © 2023，德州仪器 (TI) 公司