

## DRV8842-EP 直流电机驱动器 IC

### 1 特性

- 单路 H 桥电流控制电机驱动器
  - 驱动一个直流电机、一个步进电机线圈或其它传动器
  - 5 位绕组电流控制支持高达 32 个电流级
  - 低 MOSFET 导通电阻
- 24V/25°C 下最大驱动电流为 5A
- 内置 3.3V 基准输出
- 工业标准的 PWM 控制接口
- 8.2V 至 45V 宽工作电源电压范围
- 散热增强型表面贴装封装
- 支持国防、航天和医疗应用
  - 受控基线
  - 同一组装和测试场所
  - 同一制造场所
  - 支持军用 (-55°C 至 125°C) 温度范围
  - 延长的产品生命周期
  - 延长的产品变更通知
  - 产品可追溯性

### 2 应用范围

- 打印机
- 扫描仪
- 办公自动化设备
- 游戏机
- 工厂自动化
- 机器人

### 4 简化电路原理图

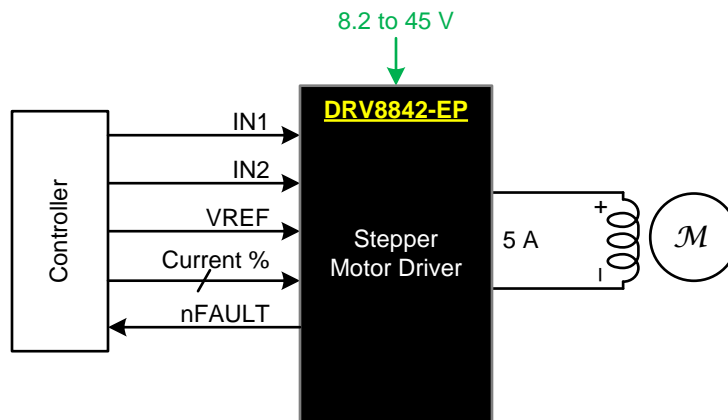

### 3 说明

DRV8842-EP 可为打印机、扫描仪以及其它自动化设备应用提供集成电机驱动器解决方案。此器件具有一个 H 桥驱动器，用于驱动一个直流电机、一个步进电机线圈或其它负载。输出驱动器块包括配置为一个 H 桥的 N 通道功率 MOSFET。DRV8842-EP 可提供最高 5A 的峰值电流或 3.5A 的 RMS 输出电流（在 24 V/25°C 且散热正常的条件下）。

提供可单独控制 H 桥每一半的独立输入。

提供用于过流保护、短路保护、欠压锁定和过热保护的内部关断功能。

DRV8842-EP 采用带有 PowerPAD™ 的 28 引脚 HTSSOP 封装（环保型：符合 RoHS 标准且不含铅/溴）。

#### 器件信息(1)

订货编号	封装	封装尺寸（标称值）
DRV8842MPWPREP	HTSSOP (28)	9.70 mm x 4.40 mm

(1) 要了解所有可用封装，请见数据表末尾的可订购产品附录。

## 目录

<b>1</b>	特性 .....	1	8.3	Feature Description .....	9
<b>2</b>	应用范围 .....	1	8.4	Device Functional Modes .....	12
<b>3</b>	说明 .....	1	<b>9</b>	<b>Application and Implementation .....</b>	<b>13</b>
<b>4</b>	简化电路原理图 .....	1	9.1	Application Information .....	13
<b>5</b>	修订历史记录 .....	2	9.2	Typical Application .....	13
<b>6</b>	<b>Pin Configuration and Functions .....</b>	<b>3</b>	<b>10</b>	<b>Power Supply Recommendations .....</b>	<b>16</b>
<b>7</b>	<b>Specifications .....</b>	<b>4</b>	10.1	Bulk Capacitance .....	16
7.1	Absolute Maximum Ratings .....	4	10.2	Power Supply and Logic Sequencing .....	16
7.2	Handling Ratings .....	4	<b>11</b>	<b>Layout .....</b>	<b>17</b>
7.3	Recommended Operating Conditions .....	4	11.1	Layout Guidelines .....	17
7.4	Thermal Information .....	5	11.2	Layout Example .....	17
7.5	Electrical Characteristics .....	6	<b>12</b>	<b>器件和文档支持 .....</b>	<b>18</b>
7.6	Motor Driver Timing Requirements .....	6	12.1	Trademarks .....	18
7.7	Typical Characteristics .....	7	12.2	Electrostatic Discharge Caution .....	18
<b>8</b>	<b>Detailed Description .....</b>	<b>8</b>	12.3	术语表 .....	18
8.1	Overview .....	8	<b>13</b>	<b>机械封装和可订购信息 .....</b>	<b>18</b>
8.2	Functional Block Diagram .....	8			

## 5 修订历史记录

日期	版本	注释
2014 年 7 月	*	最初发布版本

## 6 Pin Configuration and Functions

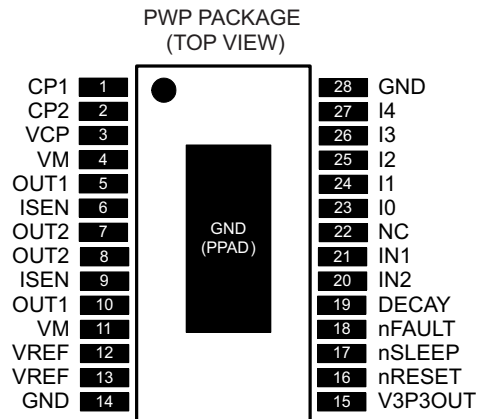

### Pin Functions

PIN		I/O <sup>(1)</sup>	DESCRIPTION	EXTERNAL COMPONENTS OR CONNECTIONS
NAME	NO.			
<b>POWER AND GROUND</b>				
GND	14	—	Device ground	
	28			
VM	4	—	Bridge A power supply	Connect to motor supply (8.2 to 45 V). Both pins must be connected to same supply.
	11			
V3P3OUT	15	O	3.3-V regulator output	Bypass to GND with a 0.47- $\mu$ F, 6.3-V ceramic capacitor. Can be used to supply VREF.
CP1	1	IO	Charge pump flying capacitor	Connect a 0.01- $\mu$ F 50-V capacitor between CP1 and CP2.
CP2	2	IO	Charge pump flying capacitor	
VCP	3	IO	High-side gate drive voltage	Connect a 0.1- $\mu$ F 16-V ceramic capacitor and a 1-M $\Omega$ resistor to VM.
<b>CONTROL</b>				
IN1	21	I	Input 1	Logic input controls state of OUT1. Internal pulldown.
IN2	20	I	Input 2	Logic input controls state of OUT2. Internal pulldown.
I0	23	I	Current set inputs	Sets winding current as a percentage of full-scale. Internal pulldown.
I1	24	I		
I2	25	I		
I3	26	I		
I4	27	I		
DECAY	19	I	Decay mode	Low = slow decay, open = mixed decay, High = fast decay. Internal pulldown and pullup.
nRESET	16	I	Reset input	Active-low reset input initializes the logic and disables the H-bridge outputs. Internal pulldown.
nSLEEP	17	I	Sleep mode input	Logic high to enable device, logic low to enter low-power sleep mode. Internal pulldown.
VREF	12	I	Current set reference input	Reference voltage for winding current set. Both pins must be connected together on the PCB.
	13			
<b>STATUS</b>				
nFAULT	18	OD	Fault	Logic low when in fault condition (over-temperature, overcurrent)
<b>OUTPUT</b>				
ISEN	6	IO	Bridge ground / Isense	Connect to current sense resistor. Both pins must be connected together on the PCB.
	9			

(1) Directions: I = input, O = output, OZ = tri-state output, OD = open-drain output, IO = input/output

**Pin Functions (continued)**

PIN		I/O <sup>(1)</sup>	DESCRIPTION	EXTERNAL COMPONENTS OR CONNECTIONS
NAME	NO.			
OUT1	5	O	Bridge output 1	Connect to motor winding. Both pins must be connected together on the PCB.
	10			
OUT2	7	O	Bridge output 2	Connect to motor winding. Both pins must be connected together on the PCB.
	8			

## 7 Specifications

### 7.1 Absolute Maximum Ratings

 over operating free-air temperature range (unless otherwise noted) <sup>(1)</sup> <sup>(2)</sup>

		MIN	MAX	UNIT
$V_{(VM)}$	Power supply voltage	-0.3	47	V
	Digital pin voltage	-0.5	7	V
$V_{(VREF)}$	Input voltage	-0.3	4	V
	ISEN pins	-0.3	0.8	V
	Peak motor drive output current, $t < 1 \mu s$	Internally limited		A
	Continuous motor drive output current <sup>(3)</sup>			5 A
	Continuous total power dissipation	See <a href="#">Thermal Information</a>		
$T_J$	Operating virtual junction temperature range	-55	150	°C

- (1) Stresses beyond those listed under *Absolute Maximum Ratings* may cause permanent damage to the device. These are stress ratings only, and functional operation of the device at these or any other conditions beyond those indicated under *Recommended Operating Conditions* is not implied. Exposure to absolute-maximum-rated conditions for extended periods may affect device reliability.
- (2) All voltage values are with respect to network ground terminal.
- (3) Power dissipation and thermal limits must be observed.

### 7.2 Handling Ratings

		MIN	MAX	UNIT	
$T_{stg}$	Storage temperature range	-60	150	°C	
$V_{(ESD)}$ <sup>(1)</sup>	Electrostatic discharge	Human body model (HBM), per ANSI/ESDA/JEDEC JS-001, all pins <sup>(2)</sup>	-500	4000	V
		Charged device model (CDM), per JEDEC specification JESD22-C101, all pins <sup>(3)</sup>	-250	1500	

- (1) Electrostatic discharge (ESD) to measure device sensitivity/immunity to damage caused by assembly line electrostatic discharges into the device.
- (2) JEDEC document JEP155 states that 500-V HBM allows safe manufacturing with a standard ESD control process. *Pins listed as 1 kV may actually have higher performance.*
- (3) JEDEC document JEP157 states that 250-V CDM allows safe manufacturing with a standard ESD control process. *Pins listed as 250 V may actually have higher performance.*

### 7.3 Recommended Operating Conditions

over operating free-air temperature range (unless otherwise noted)

		MIN	NOM	MAX	UNIT
$V_M$	Motor power supply voltage range <sup>(1)</sup>	8.2		45	V
$V_{(VREF)}$	VREF input voltage <sup>(2)</sup>	1		3.5	V
$I_{V3P3}$	V3P3OUT load current	0		1	mA
$f_{PWM}$	Externally applied PWM frequency	0		100	kHz
$T_J$	Operating virtual junction temperature range	-55		125	°C

- (1) All  $V_M$  pins must be connected to the same supply voltage.
- (2) Operational at  $V_{(VREF)}$  between 0 and 1 V, but accuracy is degraded.

## 7.4 Thermal Information

THERMAL METRIC <sup>(1)</sup>		DRV8842-EP	UNIT
		PWP	
		28 PINS	
$R_{\theta JA}$	Junction-to-ambient thermal resistance <sup>(2)</sup>	35.6	°C/W
$R_{\theta JC(top)}$	Junction-to-case (top) thermal resistance <sup>(3)</sup>	15.6	
$R_{\theta JB}$	Junction-to-board thermal resistance <sup>(4)</sup>	13.5	
$\psi_{JT}$	Junction-to-top characterization parameter <sup>(5)</sup>	0.4	
$\psi_{JB}$	Junction-to-board characterization parameter <sup>(6)</sup>	13.3	
$R_{\theta JC(bot)}$	Junction-to-case (bottom) thermal resistance <sup>(7)</sup>	1.4	

(1) For more information about traditional and new thermal metrics, see the *IC Package Thermal Metrics* application report, [SPRA953](#).

(2) The junction-to-ambient thermal resistance under natural convection is obtained in a simulation on a JEDEC-standard, high-K board, as specified in JESD51-7, in an environment described in JESD51-2a.

(3) The junction-to-case (top) thermal resistance is obtained by simulating a cold plate test on the package top. No specific JEDEC-standard test exists, but a close description can be found in the ANSI SEMI standard G30-88.

(4) The junction-to-board thermal resistance is obtained by simulating in an environment with a ring cold plate fixture to control the PCB temperature, as described in JESD51-8.

(5) The junction-to-top characterization parameter,  $\psi_{JT}$ , estimates the junction temperature of a device in a real system and is extracted from the simulation data for obtaining  $\theta_{JA}$ , using a procedure described in JESD51-2a (sections 6 and 7).

(6) The junction-to-board characterization parameter,  $\psi_{JB}$ , estimates the junction temperature of a device in a real system and is extracted from the simulation data for obtaining  $\theta_{JA}$ , using a procedure described in JESD51-2a (sections 6 and 7).

(7) The junction-to-case (bottom) thermal resistance is obtained by simulating a cold plate test on the exposed (power) pad. No specific JEDEC standard test exists, but a close description can be found in the ANSI SEMI standard G30-88.

## 7.5 Electrical Characteristics

over recommended operating junction temperature range

PARAMETER		TEST CONDITIONS	MIN	TYP	MAX	UNIT
<b>POWER SUPPLIES</b>						
$I_{VM}$	VM operating supply current	$V_M = 24\text{ V}$ , $f_{PWM} < 50\text{ kHz}$		5	8	mA
$I_{VMQ}$	VM sleep mode supply current	$V_M = 24\text{ V}$		10	20	$\mu\text{A}$
$V_{UVLO}$	VM undervoltage lockout voltage	$V_M$ rising		7.8	8.4	V
<b>V3P3OUT REGULATOR</b>						
$V_{3P3}$	V3P3OUT voltage	$I_{OUT} = 0\text{ to }1\text{ mA}$	3.1	3.3	3.5	V
<b>LOGIC-LEVEL INPUTS</b>						
$V_{IL}$	Input low voltage			0.6	0.7	V
$V_{IH}$	Input high voltage		2.2		5.25	V
$V_{HYS}$	Input hysteresis		0.3	0.45	0.65	V
$I_{IL}$	Input low current	$V_{IN} = 0$	-20		20	$\mu\text{A}$
$I_{IH}$	Input high current	$V_{IN} = 3.3\text{ V}$		33	100	$\mu\text{A}$
$R_{PD}$	Internal pulldown resistance			100		k $\Omega$
<b>nFAULT OUTPUT (OPEN-DRAIN OUTPUT)</b>						
$V_{OL}$	Output low voltage	$I_O = 5\text{ mA}$			0.5	V
$I_{OH}$	Output high leakage current	$V_O = 3.3\text{ V}$			1	$\mu\text{A}$
<b>DECAY INPUT</b>						
$V_{IL}$	Input low threshold voltage	For slow decay (brake) mode	0		0.8	V
$V_{IH}$	Input high threshold voltage	For fast decay (coast) mode	2			V
$I_{IN}$	Input current				$\pm 40$	$\mu\text{A}$
$R_{PU}$	Internal pullup resistance (to 3.3 V)			130		k $\Omega$
$R_{PD}$	Internal pulldown resistance			80		k $\Omega$
<b>H-BRIDGE FETS</b>						
$R_{DS(ON)}$	HS FET on resistance	$V_M = 24\text{ V}$ , $I_O = 1\text{ A}$		0.13	0.17	$\Omega$
$R_{DS(ON)}$	LS FET on resistance	$V_M = 24\text{ V}$ , $I_O = 1\text{ A}$		0.13	0.17	$\Omega$
$I_{OFF}$	Off-state leakage current		-79		96	$\mu\text{A}$
<b>PROTECTION CIRCUITS</b>						
$I_{OCP}$	Overcurrent protection trip level		5			A
$t_{TSD}$	Thermal shutdown temperature	Die temperature	150	160	180	$^{\circ}\text{C}$
<b>CURRENT CONTROL</b>						
$I_{REF}$	VREF input current	$V_{(VREF)} = 3.3\text{ V}$	-3		3	$\mu\text{A}$
$V_{TRIP}$	ISENSE trip voltage	$V_{(VREF)} = 3.3\text{ V}$ , 100% current setting	635	660	685	mV
$\Delta I_{TRIP}$	Current trip accuracy (relative to programmed value)	$V_{(VREF)} = 3.3\text{ V}$ , 5% current setting	-25%		25%	
		$V_{(VREF)} = 3.3\text{ V}$ , 10% to 34% current setting	-15%		15%	
		$V_{(VREF)} = 3.3\text{ V}$ , 38% to 67% current setting	-10%		10%	
		$V_{(VREF)} = 3.3\text{ V}$ , 71% to 100% current setting	-5%		5%	
$A_{ISENSE}$	Current sense amplifier gain	Reference only		5		V/V

## 7.6 Motor Driver Timing Requirements

		MIN	TYP	MAX	UNIT
$f_{PWM}$	Internal current control PWM frequency		50		kHz
$t_{BLANK}$	Current sense blanking time		3.75		$\mu\text{s}$
$t_R$	Rise time	30		220	ns
$t_F$	Fall time	30		220	ns

### 7.7 Typical Characteristics

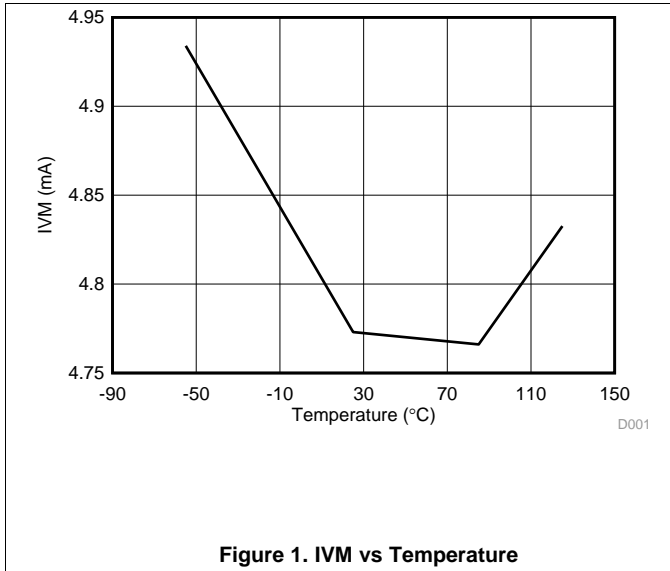

Figure 1. IVM vs Temperature

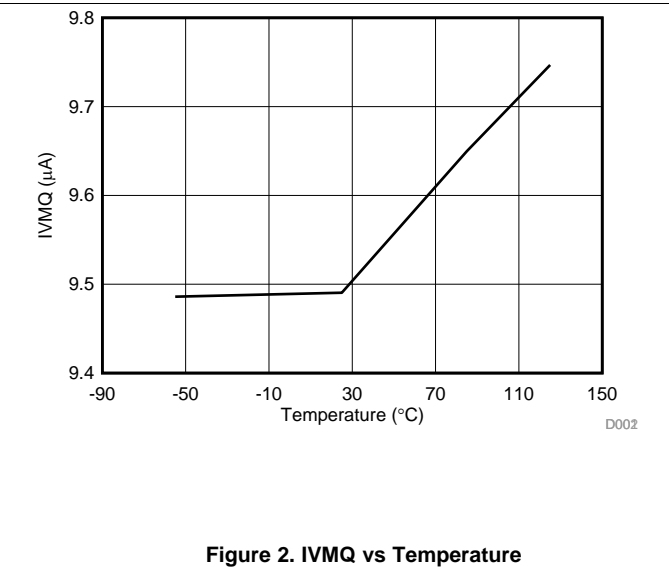

Figure 2. IVMQ vs Temperature

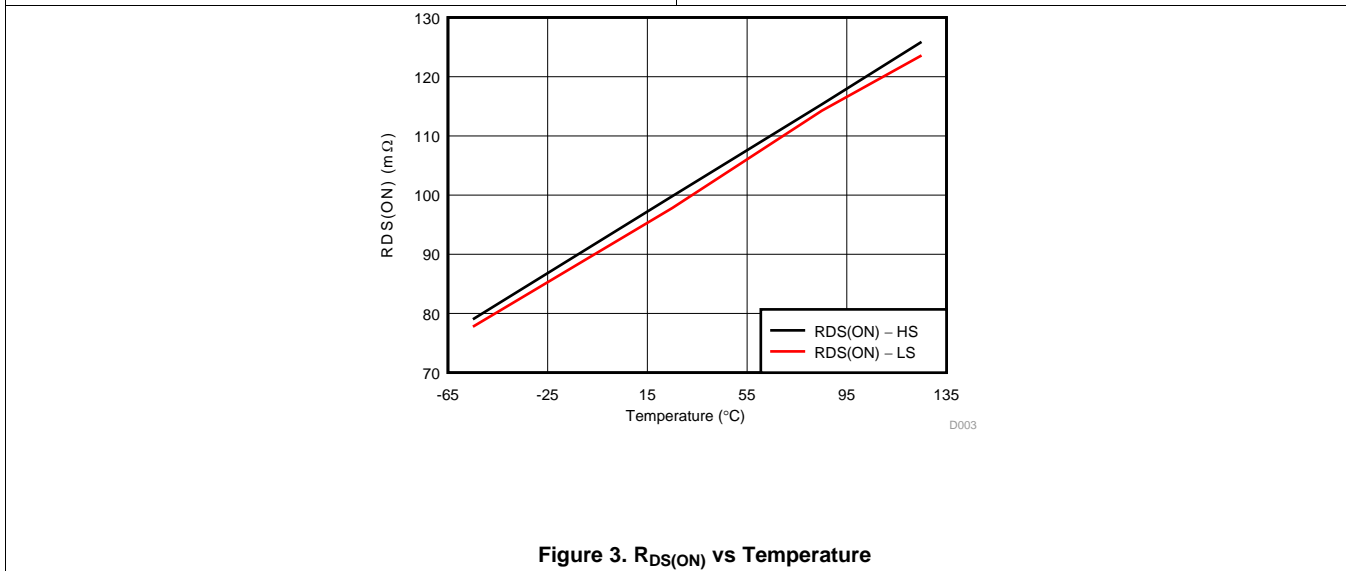

Figure 3. R<sub>DS(ON)</sub> vs Temperature

## 8 Detailed Description

### 8.1 Overview

The DRV8842-EP provides an integrated motor driver solution for printers, scanners, and other automated equipment applications. The device has one H-bridge driver, and is intended to drive one DC motor, one coil of a stepper motor, or other loads. The output driver block consists of N-channel power MOSFETs configured as an H-bridge. The DRV8842-EP can supply up to 5-A peak or 3.5-A RMS output current (with proper heatsinking at 24 V and 25°C).

### 8.2 Functional Block Diagram

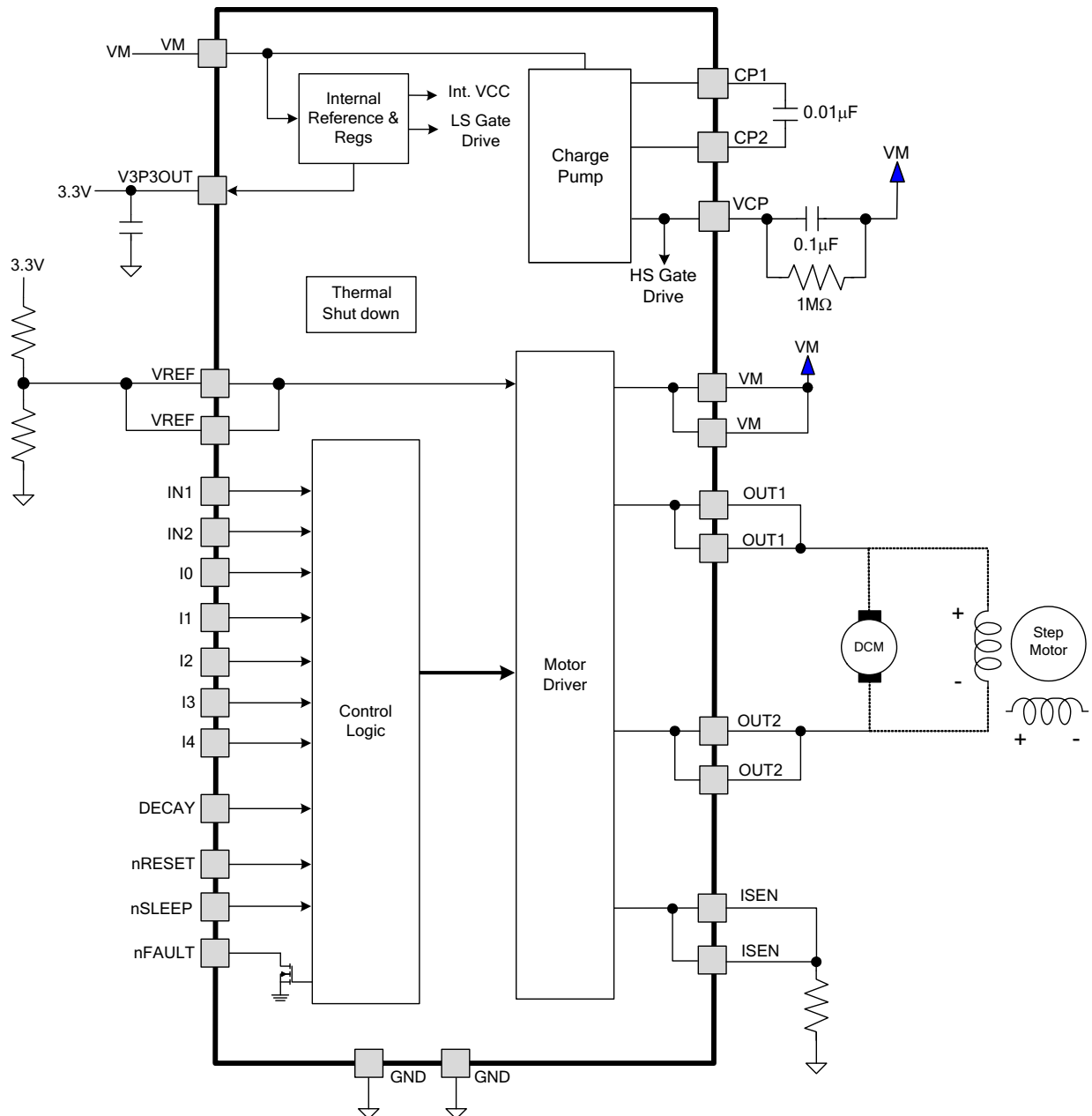



### 8.3 Feature Description

#### 8.3.1 PWM Motor Drivers

The DRV8842-EP contains one H-bridge motor driver with current-control PWM circuitry. Figure 4 shows a block diagram of the motor control circuitry.

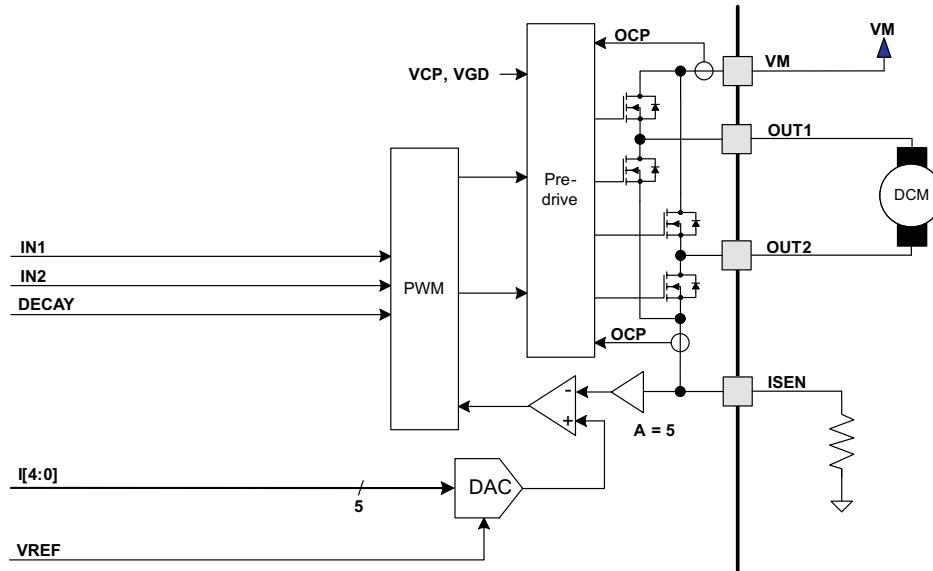

Figure 4. Motor Control Circuitry

Note that there are multiple VM, ISEN, OUT, and VREF pins. All like-named pins must be connected together on the PCB.

#### 8.3.2 Bridge Control

The IN1 and IN2 input pins directly control the state of the OUT1 and OUT2 outputs. Either input can also be used for PWM control of the load. Table 1 shows the logic.

Table 1. H-Bridge Logic

IN1	IN2	OUT1	OUT2
0	0	L	L
0	1	L	H
1	0	H	L
1	1	H	H

The control inputs have internal pulldown resistors of approximately 100 kΩ.

#### 8.3.3 Current Regulation

The maximum current through the load is regulated by a fixed-frequency PWM current regulation, or current chopping. When the H-bridge is enabled, current rises through the winding at a rate dependent on the DC voltage and inductance of the winding. After the current hits the current chopping threshold, the bridge disables the current until the beginning of the next PWM cycle.

For DC motors, current regulation is used to limit the start-up and stall current of the motor. Speed control is typically performed by providing an external PWM signal to the IN1 or IN2 input pins.

If the current regulation feature is not needed, it can be disabled by connecting the ISEN pins directly to ground and the VREF pins to V3P3.

The PWM chopping current is set by a comparator which compares the voltage across a current sense resistor connected to the ISEN pins, multiplied by a factor of 5, with a reference voltage. The reference voltage is input from the VREF pins, and is scaled by a 5-bit DAC that allows current settings of 0% to 100% in an approximately sinusoidal sequence.

The full-scale (100%) chopping current is calculated in [Equation 1](#).

$$I_{\text{CHOP}} = \frac{V_{(\text{VREF})}}{5 \times R_{\text{ISENSE}}} \quad (1)$$

Example:

If using a 0.25-Ω sense resistor and the VREF pins are 2.5 V, the full-scale (100%) chopping current is 2.5 V / (5 × 0.25 Ω) = 2 A.

Five input pins (I0 through I4) are used to scale the current in the bridge as a percentage of the full-scale current set by the VREF input pin and sense resistance. The I0 through I4 pins have internal pulldown resistors of approximately 100 kΩ. The function of the pins is shown in [Table 2](#).

**Table 2. Pin Functions**

I[4..0]	RELATIVE CURRENT (% FULL-SCALE CHOPPING CURRENT)
0x00h	0%
0x01h	5%
0x02h	10%
0x03h	15%
0x04h	20%
0x05h	24%
0x06h	29%
0x07h	34%
0x08h	38%
0x09h	43%
0x0Ah	47%
0x0Bh	51%
0x0Ch	56%
0x0Dh	60%
0x0Eh	63%
0x0Fh	67%
0x10h	71%
0x11h	74%
0x12h	77%
0x13h	80%
0x14h	83%
0x15h	86%
0x16h	88%
0x17h	90%
0x18h	92%
0x19h	94%
0x1Ah	96%
0x1Bh	97%
0x1Ch	98%
0x1Dh	99%
0x1Eh	100%
0x1Fh	100%

### 8.3.4 Blanking Time

After the current is enabled in an H-bridge, the voltage on the ISEN pin is ignored for a fixed period of time before enabling the current sense circuitry. This blanking time is fixed at 3.75  $\mu$ s. Note that the blanking time also sets the minimum on-time of the PWM.

### 8.3.5 nRESET and nSLEEP Operation

The nRESET pin, when driven active low, resets the internal logic. It also disables the H-bridge driver. All inputs are ignored while nRESET is active.

Driving nSLEEP low puts the device into a low-power sleep state. In this state, the H-bridges are disabled, the gate drive charge pump is stopped, the V3P3OUT regulator is disabled, and all internal clocks are stopped. In this state, all inputs are ignored until nSLEEP returns inactive high. When returning from sleep mode, some time (approximately 1 ms) needs to pass before the motor driver becomes fully operational. Note that nRESET and nSLEEP have internal pulldown resistors of approximately 100 k $\Omega$ . These signals need to be driven to logic high for device operation.

### 8.3.6 Protection Circuits

The DRV8842-EP is fully protected against undervoltage, overcurrent, and overtemperature events.

#### 8.3.6.1 Overcurrent Protection (OCP)

An analog current limit circuit on each FET limits the current through the FET by removing the gate drive. If this analog current limit persists for longer than the OCP time, all FETs in the H-bridge are disabled and the nFAULT pin is driven low. The device remains disabled until either nRESET pin is applied, or VM is removed and reapplied.

Overcurrent conditions on both high-side and low-side devices (that is, a short to ground, supply, or across the motor winding) all result in an overcurrent shutdown. Note that overcurrent protection does not use the current sense circuitry used for PWM current control, and is independent of the I<sub>SENSE</sub> resistor value or VREF voltage.

#### 8.3.6.2 Thermal Shutdown (TSD)

If the die temperature exceeds safe limits, all FETs in the H-bridge are disabled and the nFAULT pin is driven low. After the die temperature has fallen to a safe level, operation automatically resumes.

#### 8.3.6.3 Undervoltage Lockout (UVLO)

If at any time the voltage on the VM pins falls below the UVLO threshold voltage, all circuitry in the device is disabled and internal logic is reset. Operation resumes when V<sub>M</sub> rises above the UVLO threshold.

### 8.3.7 Thermal Protection

The DRV8842-EP has TSD as described in [Thermal Shutdown \(TSD\)](#). If the die temperature exceeds approximately 150°C, the device is disabled until the temperature drops to a safe level.

Any tendency of the device to enter TSD is an indication of either excessive power dissipation, insufficient heatsinking, or too high an ambient temperature.

### 8.3.8 Heatsinking

The PowerPAD™ package uses an exposed pad to remove heat from the device. For proper operation, this pad must be thermally connected to copper on the PCB to dissipate heat. On a multi-layer PCB with a ground plane, this can be accomplished by adding a number of vias to connect the thermal pad to the ground plane. On PCBs without internal planes, copper area can be added on either side of the PCB to dissipate heat. If the copper area is on the opposite side of the PCB from the device, thermal vias are used to transfer the heat between top and bottom layers.

For details about how to design the PCB, refer to TI application report [SLMA002, PowerPAD™ Thermally Enhanced Package](#) and TI application brief [SLMA004, PowerPAD™ Made Easy](#), available at [www.ti.com](http://www.ti.com).

In general, the more copper area that can be provided, the more power can be dissipated.

## 8.4 Device Functional Modes

### 8.4.1 Decay Mode

During PWM current chopping, the H-bridge is enabled to drive current through the motor winding until it reaches the PWM current chopping threshold (see Figure 5, case 1). The current flow direction shown indicates the state when the IN1 pin is high and the IN2 pin is low.

After the chopping current threshold is reached, the H-bridge can operate in two different states, fast decay or slow decay.

In fast decay mode, after the PWM chopping current level is reached, the H-bridge reverses state to allow winding current to flow in a reverse direction. As the winding current approaches 0, the bridge is disabled to prevent any reverse current flow. Figure 5 case 2 shows fast decay mode.

In slow decay mode, winding current is recirculated by enabling both of the low-side FETs in the bridge (see Figure 5, case 3).

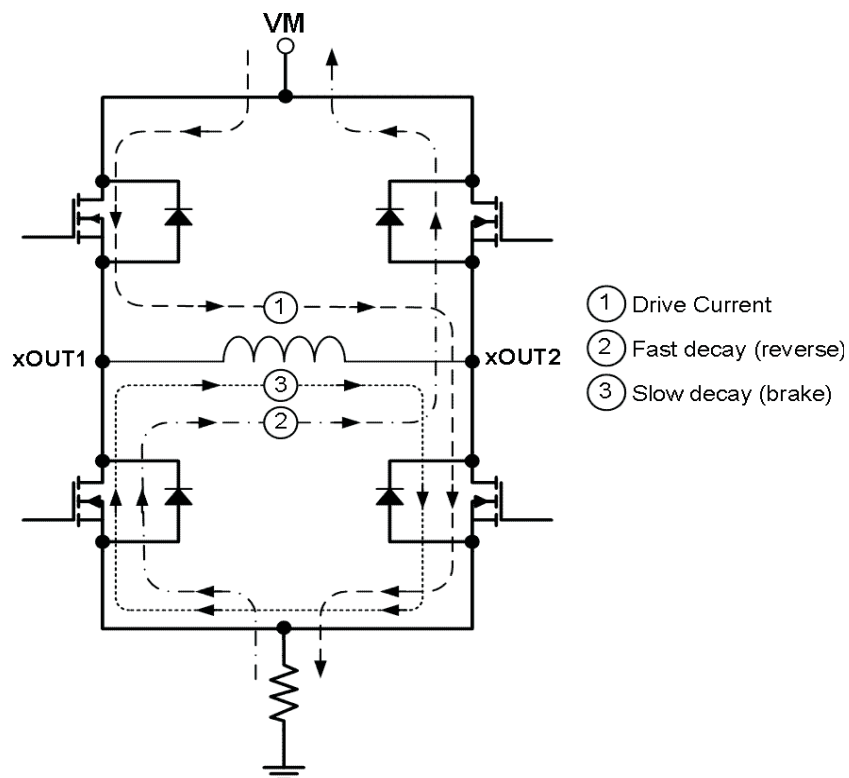

**Figure 5. Decay Mode**

The DRV8842-EP supports fast decay, slow decay, and a mixed decay mode. Slow, fast, or mixed decay mode is selected by the state of the DECAY pin. Logic low selects slow decay. Open selects mixed decay operation. And, logic high sets fast decay mode. The DECAY pin has both an internal pullup resistor of approximately 130 k $\Omega$  and an internal pulldown resistor of approximately 80 k $\Omega$ . This sets the mixed decay mode if the pin is left open or undriven.

Mixed decay mode begins as fast decay, but at a fixed period of time (75% of the PWM cycle) switches to slow decay mode for the remainder of the fixed PWM period.

## 9 Application and Implementation

### 9.1 Application Information

The DRV8842-EP is used in DC motor control. This integrated driver drives up to a 5-A peak with precise winding current control. The motor is controlled through a PWM interface and device faults are reported through the nFAULT pin. The following design is a common application of the DRV8842-EP.

### 9.2 Typical Application

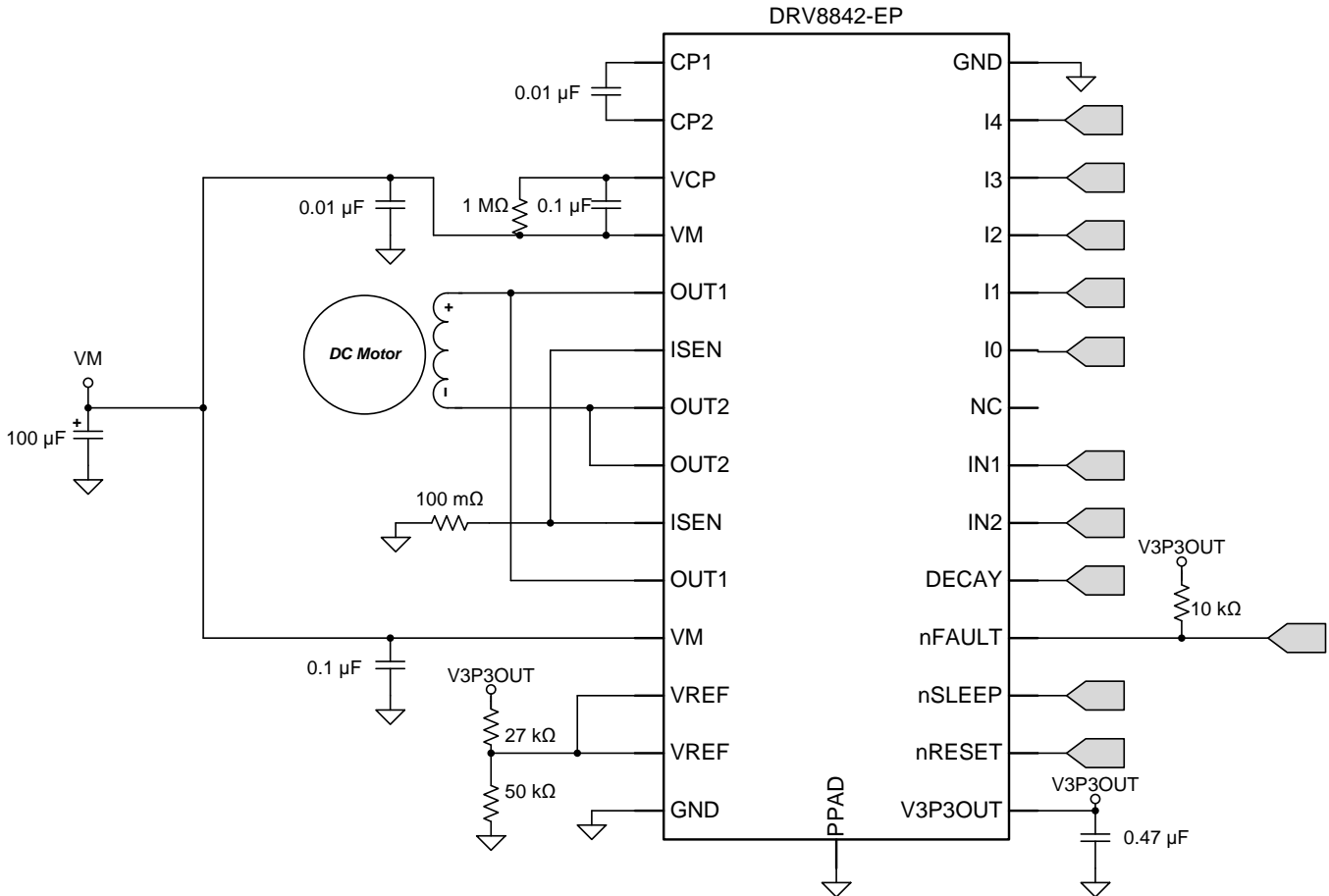

#### 9.2.1 Design Requirements

Design Parameters	Reference	Example Value
Supply voltage	VM	24 V
Motor winding resistance	$R_L$	13.23 $\Omega$
Motor winding inductance	$I_L$	4.03 mH
Motor type	BDC	Brushed DC motor
Sense resistor	$R_{SENSE}$	100 m $\Omega$
Full-scale current	$I_{FS}$	3.5 A

## 9.2.2 Detailed Design Procedure

### 9.2.2.1 Power Dissipation

Average power dissipation in the DRV8842-EP when running a DC motor can be roughly estimated by [Equation 2](#).

$$P = 2 \times R_{DS(ON)} \times (I_{OUT})^2$$

where

- P is the power dissipation of one H-bridge
- $R_{DS(ON)}$  is the resistance of each FET
- $I_{OUT}$  is the RMS output current being applied to each winding (2)

$I_{OUT}$  is equal to the average current drawn by the DC motor. Note that at start-up and fault conditions, this current is much higher than normal running current; also consider the peak currents and their duration. The factor of 2 is due to two FETs conducting winding current (one high side and one low side) at any instant.

The maximum amount of power that can be dissipated in the device depends on ambient temperature and heatsinking.

Note that  $R_{DS(ON)}$  increases with temperature, so as the device heats, the power dissipation increases. Take this into consideration when sizing the heatsink.

### 9.2.2.2 Current Regulation Considerations

For the DRV8842-EP, the set full-scale current ( $I_{FS}$ ) is the maximum current that can be driven. This quantity depends on the  $V_{REF}$  analog voltage and the sense resistor value ( $R_{SENSE}$ ). The gain of DRV8842-EP is set for 5 V/V. This value can be adjusted from 0% to 100% through the use of the relative current bits I[4:0].

$$I_{FS} \text{ (A)} = \frac{V_{(VREF)} \text{ (V)}}{A_V \times R_{SENSE} \text{ (\Omega)}} = \frac{V_{(VREF)} \text{ (V)}}{5 \times R_{SENSE} \text{ (\Omega)}} \quad (3)$$

To achieve  $I_{FS} = 3.5 \text{ A}$  with  $R_{SENSE}$  of  $0.1 \text{ }\Omega$ ,  $V_{(VREF)}$  should be  $1.75 \text{ V}$ , and I[4:0] should be 0x1F.

### 9.2.2.3 Slow, Fast, and Mixed Decay Modes

The DRV8842-EP supports three different decay modes: slow decay, fast decay, and mixed decay. The current through the motor winding is regulated using a fixed-frequency PWM scheme. This means that after any drive phase, when a motor winding current has hit the current chopping threshold ( $I_{TRIP}$ ), the DRV8842-EP places the winding in one of the three decay modes until the PWM cycle has expired. After, a new drive phase starts.

The blanking time,  $T_{BLANK}$ , defines the minimum drive time for the current chopping.  $I_{TRIP}$  is ignored during  $T_{BLANK}$ , so the winding current may overshoot the trip level.

### 9.2.3 Application Curves

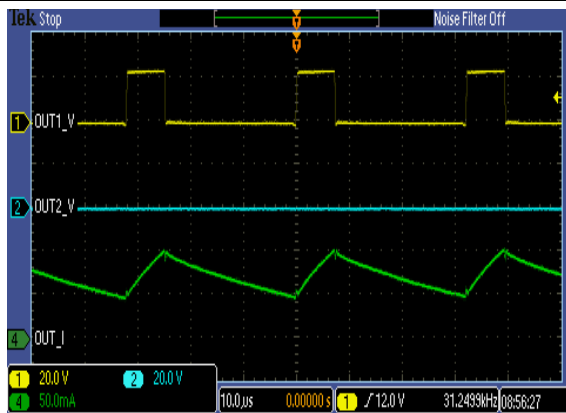

Figure 6. 25% Duty Cycle, Forward Direction

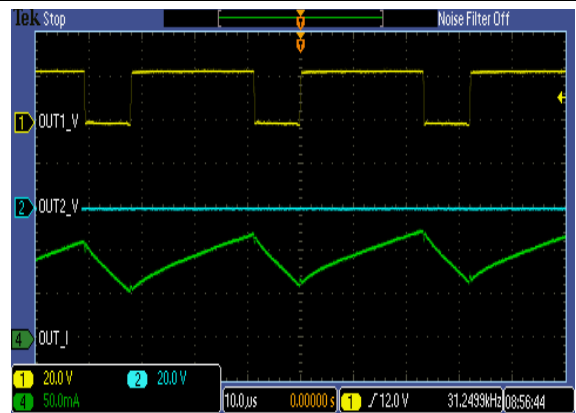

Figure 7. 75% Duty Cycle, Forward Direction

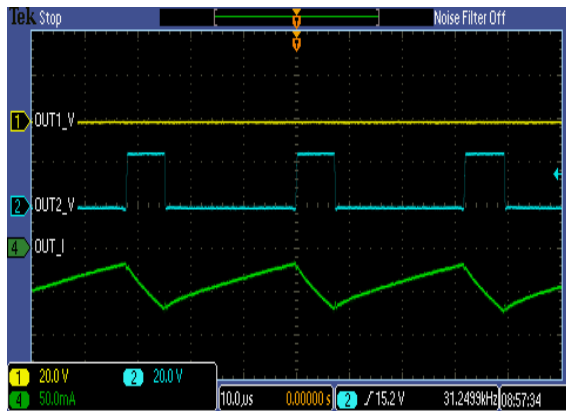

Figure 8. 25% Duty Cycle, Reverse Direction

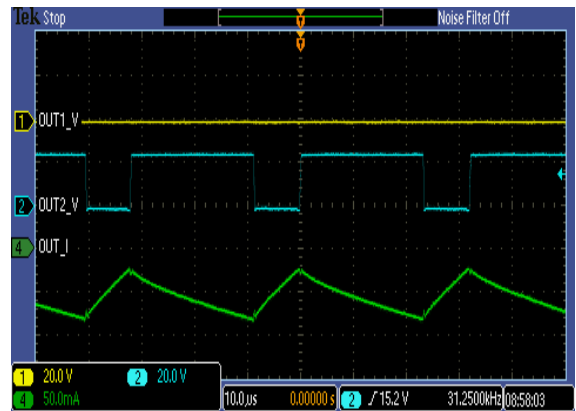

Figure 9. 75% Duty Cycle, Reverse Direction

## 10 Power Supply Recommendations

The DRV8842-EP is designed to operate from an input voltage supply (VM) range between 8.2 and 45 V. Two 0.1- $\mu\text{F}$  ceramic capacitors rated for VM must be placed as close as possible to the VM pins respectively (one on each pin). In addition to the local decoupling caps, additional bulk capacitance is required and must be sized according to the application requirements.

### 10.1 Bulk Capacitance

Bulk capacitance sizing is an important factor in motor drive system design. It depends on a variety of factors including:

- Type of power supply
- Acceptable supply voltage ripple
- Parasitic inductance in the power supply wiring
- Type of motor (brushed DC, brushless DC, stepper)
- Motor startup current
- Motor braking method

The inductance between the power supply and motor drive system limits the rate current can change from the power supply. If the local bulk capacitance is too small, the system responds to excessive current demands or dumps from the motor with a change in voltage. The designer should size the bulk capacitance to meet acceptable voltage ripple levels.

The data sheet generally provides a recommended value, but system-level testing is required to determine the appropriate sized bulk capacitor.

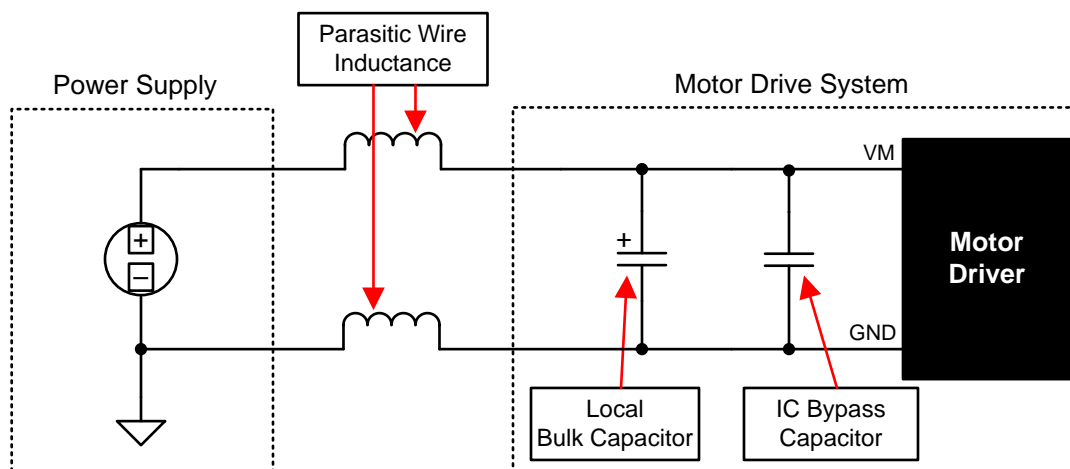

**Figure 10. Setup of Motor Drive System With External Power Supply**

### 10.2 Power Supply and Logic Sequencing

There is no specific sequence for powering-up the DRV8842-EP. It is okay for digital input signals to be present before VM is applied. After VM is applied to the DRV8842-EP, the device begins operation based on the status of the control pins.



## 11 Layout

### 11.1 Layout Guidelines

The VM pins should be bypassed to GND using low-ESR ceramic bypass capacitors with a recommended value of 0.1- $\mu$ F rated for VM. This capacitor should be placed as close to the VM pins as possible with a thick trace or ground plane connection to the device GND pin.

The VM pins must be bypassed to ground using an appropriate bulk capacitor. This component may be an electrolytic and should be located close to the DRV8842-EP.

A low-ESR ceramic capacitor must be placed in between the CPL and CPH pins. TI recommends a value of 0.01- $\mu$ F rated for VM. Place this component as close to the pins as possible.

A low-ESR ceramic capacitor must be placed in between the VM and VCP pins. TI recommends a value of 0.1- $\mu$ F rated for 16 V. Place this component as close to the pins as possible. Also, place a 1-M $\Omega$  resistor between VCP and VM.

Bypass V3P3 to ground with a ceramic capacitor rated 6.3 V. Place this bypass capacitor as close to the pin as possible.

### 11.2 Layout Example

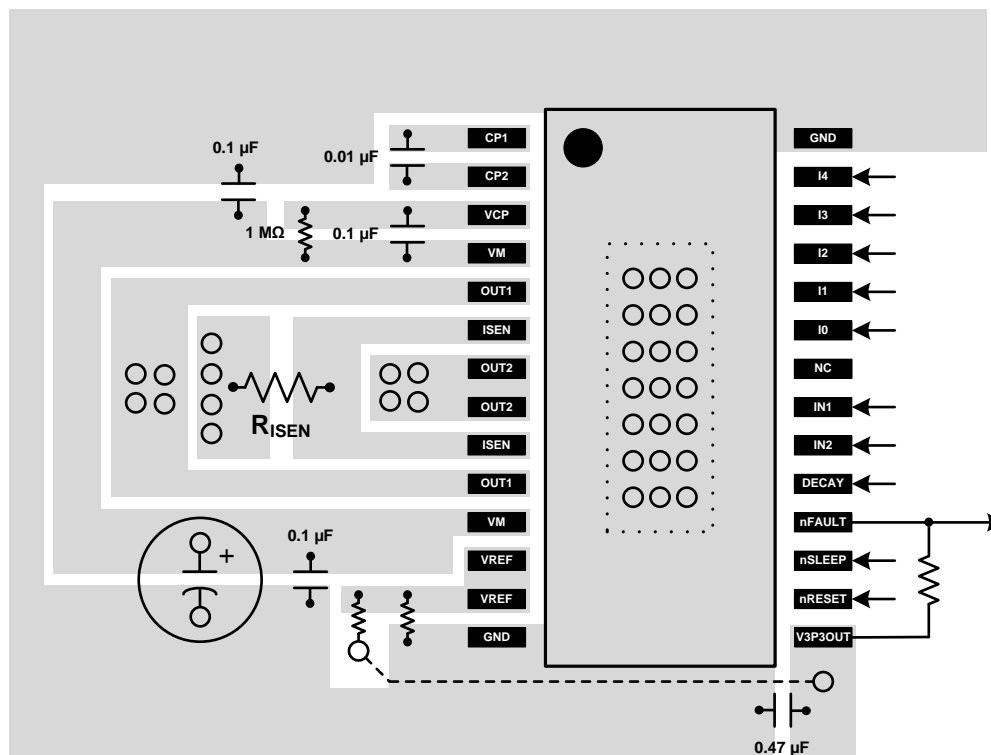

## 12 器件和文档支持

### 12.1 Trademarks

PowerPAD is a trademark of Texas Instruments.

### 12.2 Electrostatic Discharge Caution



These devices have limited built-in ESD protection. The leads should be shorted together or the device placed in conductive foam during storage or handling to prevent electrostatic damage to the MOS gates.

### 12.3 术语表

[SLYZ022](#) — *TI* 术语表。

这份术语表列出并解释术语、首字母缩略词和定义。

## 13 机械封装和可订购信息

以下页中包括机械封装和可订购信息。 这些信息是针对指定器件可提供的最新数据。 这些数据会在无通知且不对本文档进行修订的情况下发生改变。 欲获得该数据表的浏览器版本，请查阅左侧的导航栏。

## 重要声明

德州仪器(TI)及其下属子公司有权根据 JESD46 最新标准,对所提供的产品和服务进行更正、修改、增强、改进或其它更改,并有权根据 JESD48 最新标准中止提供任何产品和服务。客户在下订单前应获取最新的相关信息,并验证这些信息是否完整且是最新的。所有产品的销售都遵循在订单确认时所提供的TI 销售条款与条件。

TI 保证其所销售的组件的性能符合产品销售时 TI 半导体产品销售条件与条款的适用规范。仅在 TI 保证的范围内,且 TI 认为有必要时才会使用测试或其它质量控制技术。除非适用法律做出了硬性规定,否则没有必要对每种组件的所有参数进行测试。

TI 对应用帮助或客户产品设计不承担任何义务。客户应对其使用 TI 组件的产品和应用自行负责。为尽量减小与客户产品和应用相关的风险,客户应提供充分的设计与操作安全措施。

TI 不对任何 TI 专利权、版权、屏蔽作品权或其它与使用了 TI 组件或服务的组合设备、机器或流程相关的 TI 知识产权中授予的直接或隐含权限作出任何保证或解释。TI 所发布的与第三方产品或服务有关的信息,不能构成从 TI 获得使用这些产品或服务的许可、授权、或认可。使用此类信息可能需要获得第三方的专利权或其它知识产权方面的许可,或是 TI 的专利权或其它知识产权方面的许可。

对于 TI 的产品手册或数据表中 TI 信息的重要部分,仅在没有对内容进行任何篡改且带有相关授权、条件、限制和声明的情况下才允许进行复制。TI 对此类篡改过的文件不承担任何责任或义务。复制第三方的信息可能需要服从额外的限制条件。

在转售 TI 组件或服务时,如果对该组件或服务参数的陈述与 TI 标明的参数相比存在差异或虚假成分,则会失去相关 TI 组件或服务的所有明示或暗示授权,且这是不正当的、欺诈性商业行为。TI 对任何此类虚假陈述均不承担任何责任或义务。

客户认可并同意,尽管任何应用相关信息或支持仍可能由 TI 提供,但他们将独立负责满足与其产品及其在应用中使用的 TI 产品相关的所有法律、法规和安全相关要求。客户声明并同意,他们具备制定与实施安全措施所需的全部专业技术和知识,可预见故障的危险后果、监测故障及其后果、降低有可能造成人身伤害的故障的发生机率并采取适当的补救措施。客户将全额赔偿因在此类安全关键应用中使用任何 TI 组件而对 TI 及其代理造成的任何损失。

在某些场合中,为了推进安全相关应用有可能对 TI 组件进行特别的促销。TI 的目标是利用此类组件帮助客户设计和创立其特有的可满足适用的功能安全性标准和要求的终端产品解决方案。尽管如此,此类组件仍然服从这些条款。

TI 组件未获得用于 FDA Class III (或类似的生命攸关医疗设备)的授权许可,除非各方授权官员已经达成了专门管控此类使用的特别协议。

只有那些 TI 特别注明属于军用等级或“增强型塑料”的 TI 组件才是设计或专门用于军事/航空应用或环境的。购买者认可并同意,对并非指定向军事或航空航天用途的 TI 组件进行军事或航空航天方面的应用,其风险由客户单独承担,并且由客户独立负责满足与此类使用相关的所有法律和法规要求。

TI 已明确指定符合 ISO/TS16949 要求的产品,这些产品主要用于汽车。在任何情况下,因使用非指定产品而无法达到 ISO/TS16949 要求, TI 不承担任何责任。

	产品		应用
数字音频	<a href="http://www.ti.com.cn/audio">www.ti.com.cn/audio</a>	通信与电信	<a href="http://www.ti.com.cn/telecom">www.ti.com.cn/telecom</a>
放大器和线性器件	<a href="http://www.ti.com.cn/amplifiers">www.ti.com.cn/amplifiers</a>	计算机及周边	<a href="http://www.ti.com.cn/computer">www.ti.com.cn/computer</a>
数据转换器	<a href="http://www.ti.com.cn/dataconverters">www.ti.com.cn/dataconverters</a>	消费电子	<a href="http://www.ti.com.cn/consumer-apps">www.ti.com.cn/consumer-apps</a>
DLP® 产品	<a href="http://www.dlp.com">www.dlp.com</a>	能源	<a href="http://www.ti.com.cn/energy">www.ti.com.cn/energy</a>
DSP - 数字信号处理器	<a href="http://www.ti.com.cn/dsp">www.ti.com.cn/dsp</a>	工业应用	<a href="http://www.ti.com.cn/industrial">www.ti.com.cn/industrial</a>
时钟和计时器	<a href="http://www.ti.com.cn/clockandtimers">www.ti.com.cn/clockandtimers</a>	医疗电子	<a href="http://www.ti.com.cn/medical">www.ti.com.cn/medical</a>
接口	<a href="http://www.ti.com.cn/interface">www.ti.com.cn/interface</a>	安防应用	<a href="http://www.ti.com.cn/security">www.ti.com.cn/security</a>
逻辑	<a href="http://www.ti.com.cn/logic">www.ti.com.cn/logic</a>	汽车电子	<a href="http://www.ti.com.cn/automotive">www.ti.com.cn/automotive</a>
电源管理	<a href="http://www.ti.com.cn/power">www.ti.com.cn/power</a>	视频和影像	<a href="http://www.ti.com.cn/video">www.ti.com.cn/video</a>
微控制器 (MCU)	<a href="http://www.ti.com.cn/microcontrollers">www.ti.com.cn/microcontrollers</a>		
RFID 系统	<a href="http://www.ti.com.cn/rfidsys">www.ti.com.cn/rfidsys</a>		
OMAP应用处理器	<a href="http://www.ti.com/omap">www.ti.com/omap</a>		
无线连通性	<a href="http://www.ti.com.cn/wirelessconnectivity">www.ti.com.cn/wirelessconnectivity</a>	德州仪器在线技术支持社区	<a href="http://www.deyisupport.com">www.deyisupport.com</a>

邮寄地址: 上海市浦东新区世纪大道1568号, 中建大厦32楼邮政编码: 200122  
Copyright © 2014, 德州仪器半导体技术(上海)有限公司

**PACKAGING INFORMATION**

Orderable Device	Status (1)	Package Type	Package Drawing	Pins	Package Qty	Eco Plan (2)	Lead finish/ Ball material (6)	MSL Peak Temp (3)	Op Temp (°C)	Device Marking (4/5)	Samples
DRV8842MPWPREP	ACTIVE	HTSSOP	PWP	28	2000	RoHS & Green	NIPDAU	Level-3-260C-168 HR	-55 to 125	DRV8842EP	<a href="#">Samples</a>
V62/14615-01XE	ACTIVE	HTSSOP	PWP	28	2000	RoHS & Green	NIPDAU	Level-3-260C-168 HR	-55 to 125	DRV8842EP	<a href="#">Samples</a>

(1) The marketing status values are defined as follows:

**ACTIVE:** Product device recommended for new designs.

**LIFEBUY:** TI has announced that the device will be discontinued, and a lifetime-buy period is in effect.

**NRND:** Not recommended for new designs. Device is in production to support existing customers, but TI does not recommend using this part in a new design.

**PREVIEW:** Device has been announced but is not in production. Samples may or may not be available.

**OBSOLETE:** TI has discontinued the production of the device.

(2) **RoHS:** TI defines "RoHS" to mean semiconductor products that are compliant with the current EU RoHS requirements for all 10 RoHS substances, including the requirement that RoHS substance do not exceed 0.1% by weight in homogeneous materials. Where designed to be soldered at high temperatures, "RoHS" products are suitable for use in specified lead-free processes. TI may reference these types of products as "Pb-Free".

**RoHS Exempt:** TI defines "RoHS Exempt" to mean products that contain lead but are compliant with EU RoHS pursuant to a specific EU RoHS exemption.

**Green:** TI defines "Green" to mean the content of Chlorine (Cl) and Bromine (Br) based flame retardants meet JS709B low halogen requirements of <=1000ppm threshold. Antimony trioxide based flame retardants must also meet the <=1000ppm threshold requirement.

(3) MSL, Peak Temp. - The Moisture Sensitivity Level rating according to the JEDEC industry standard classifications, and peak solder temperature.

(4) There may be additional marking, which relates to the logo, the lot trace code information, or the environmental category on the device.

(5) Multiple Device Markings will be inside parentheses. Only one Device Marking contained in parentheses and separated by a "~" will appear on a device. If a line is indented then it is a continuation of the previous line and the two combined represent the entire Device Marking for that device.

(6) Lead finish/Ball material - Orderable Devices may have multiple material finish options. Finish options are separated by a vertical ruled line. Lead finish/Ball material values may wrap to two lines if the finish value exceeds the maximum column width.

**Important Information and Disclaimer:**The information provided on this page represents TI's knowledge and belief as of the date that it is provided. TI bases its knowledge and belief on information provided by third parties, and makes no representation or warranty as to the accuracy of such information. Efforts are underway to better integrate information from third parties. TI has taken and continues to take reasonable steps to provide representative and accurate information but may not have conducted destructive testing or chemical analysis on incoming materials and chemicals. TI and TI suppliers consider certain information to be proprietary, and thus CAS numbers and other limited information may not be available for release.

In no event shall TI's liability arising out of such information exceed the total purchase price of the TI part(s) at issue in this document sold by TI to Customer on an annual basis.



## GENERIC PACKAGE VIEW

**PWP 28**

**PowerPAD™ TSSOP - 1.2 mm max height**

4.4 x 9.7, 0.65 mm pitch

SMALL OUTLINE PACKAGE

This image is a representation of the package family, actual package may vary.  
Refer to the product data sheet for package details.

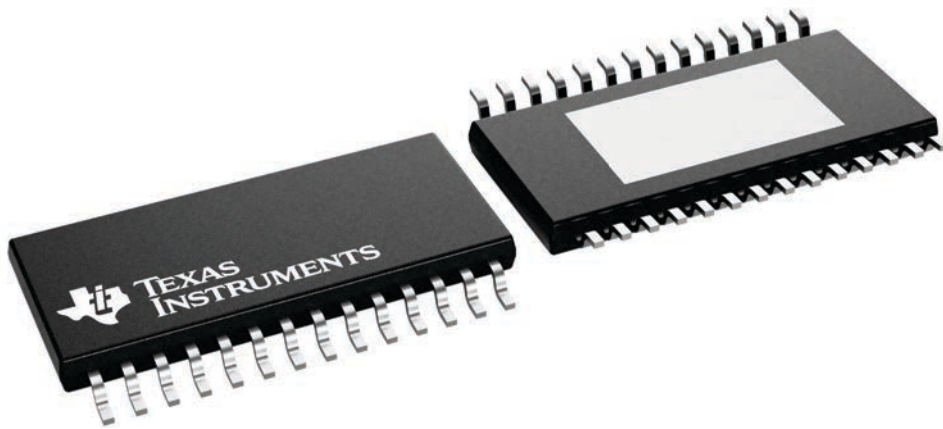

4224765/B

# PWP0028C

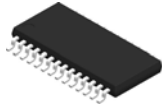

# PACKAGE OUTLINE

## PowerPAD™ TSSOP - 1.2 mm max height

SMALL OUTLINE PACKAGE

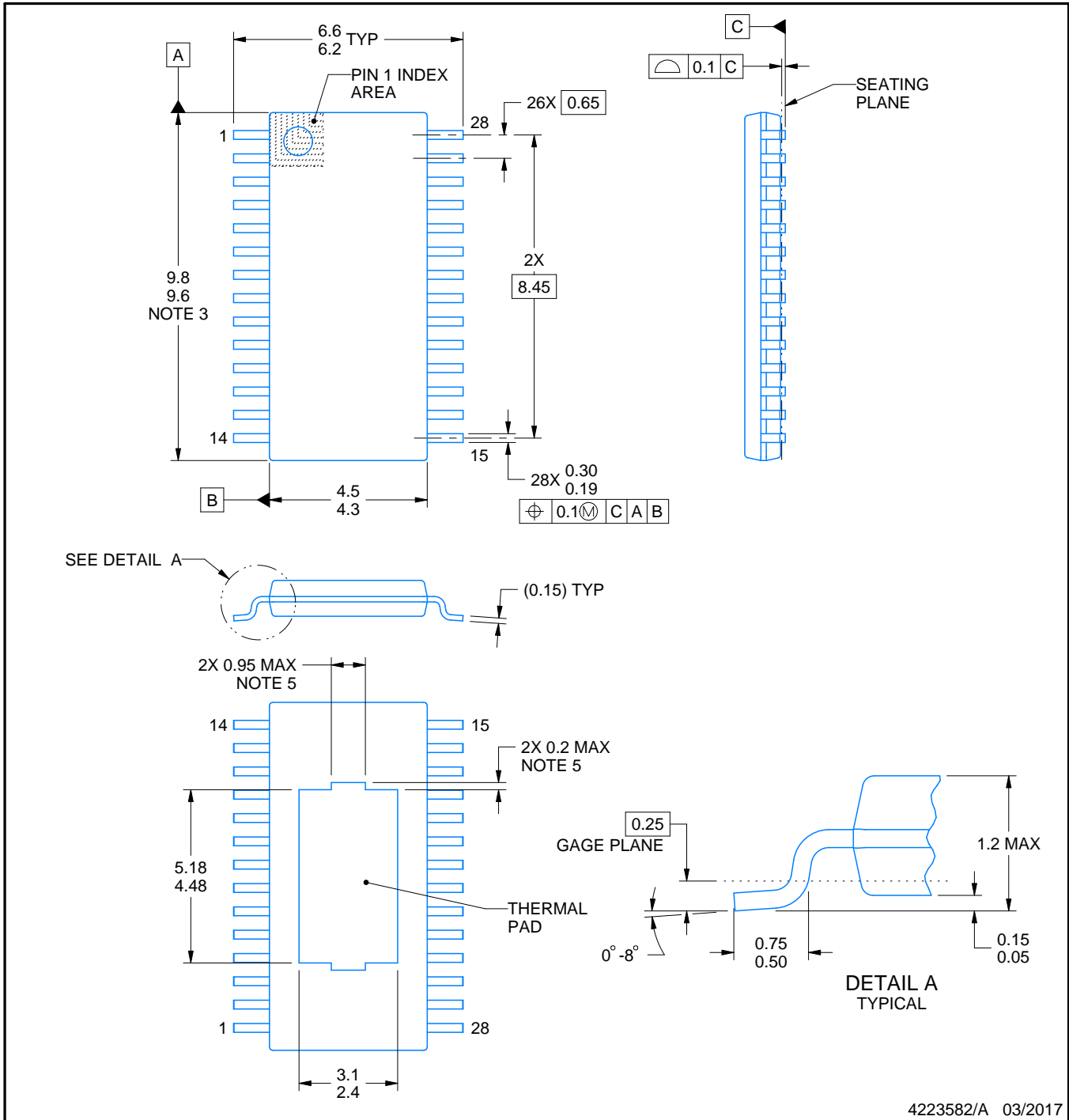

4223582/A 03/2017

### NOTES:

PowerPAD is a trademark of Texas Instruments.

1. All linear dimensions are in millimeters. Any dimensions in parenthesis are for reference only. Dimensioning and tolerancing per ASME Y14.5M.
2. This drawing is subject to change without notice.
3. This dimension does not include mold flash, protrusions, or gate burrs. Mold flash, protrusions, or gate burrs shall not exceed 0.15 mm per side.
4. Reference JEDEC registration MO-153.
5. Features may differ or may not be present.

# EXAMPLE BOARD LAYOUT

PWP0028C

PowerPAD™ TSSOP - 1.2 mm max height

SMALL OUTLINE PACKAGE

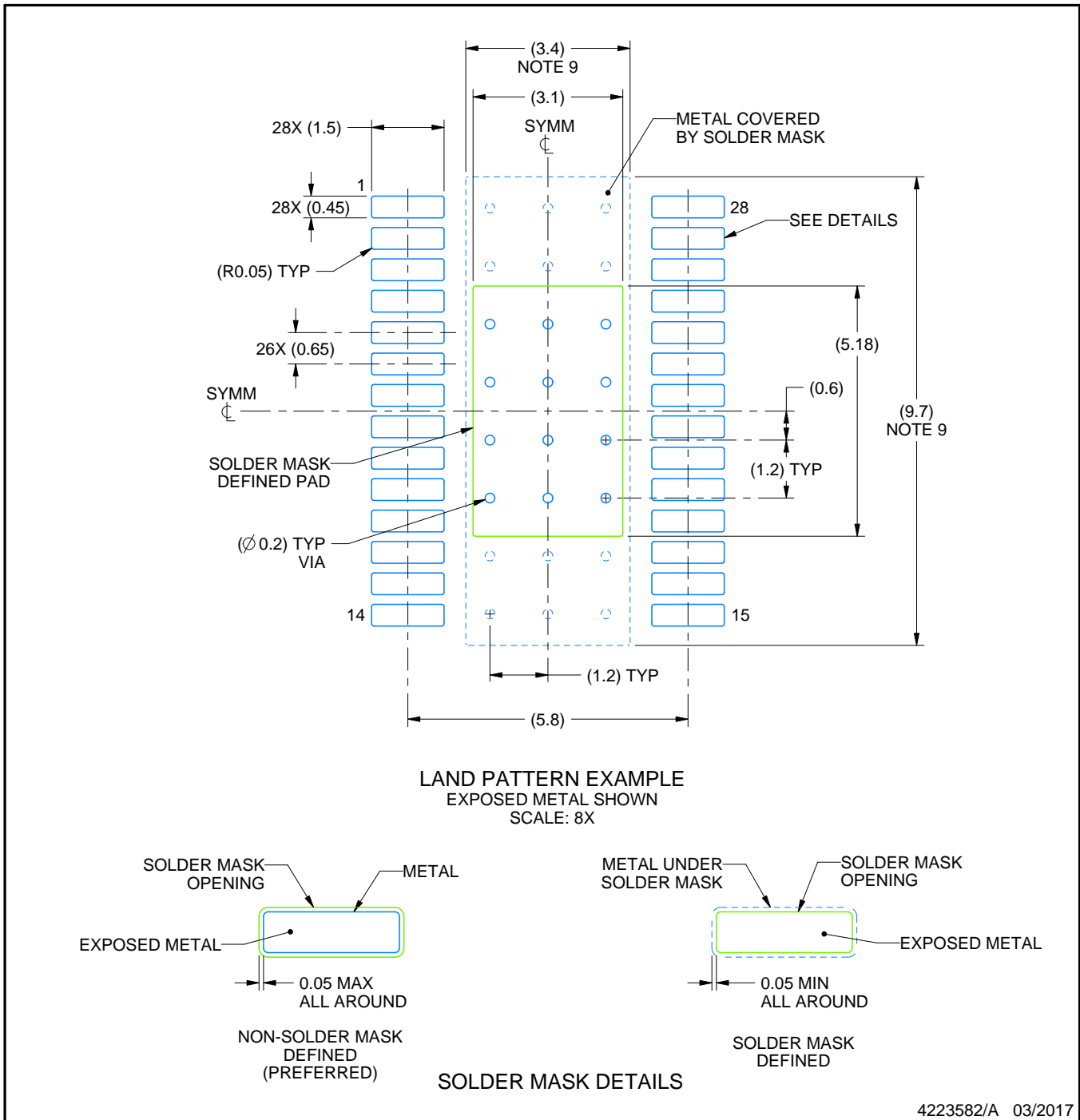

NOTES: (continued)

6. Publication IPC-7351 may have alternate designs.
7. Solder mask tolerances between and around signal pads can vary based on board fabrication site.
8. This package is designed to be soldered to a thermal pad on the board. For more information, see Texas Instruments literature numbers SLMA002 ([www.ti.com/lit/slma002](http://www.ti.com/lit/slma002)) and SLMA004 ([www.ti.com/lit/slma004](http://www.ti.com/lit/slma004)).
9. Size of metal pad may vary due to creepage requirement.
10. Vias are optional depending on application, refer to device data sheet. It is recommended that vias under paste be filled, plugged or tented.



# EXAMPLE STENCIL DESIGN

PWP0028C

PowerPAD™ TSSOP - 1.2 mm max height

SMALL OUTLINE PACKAGE

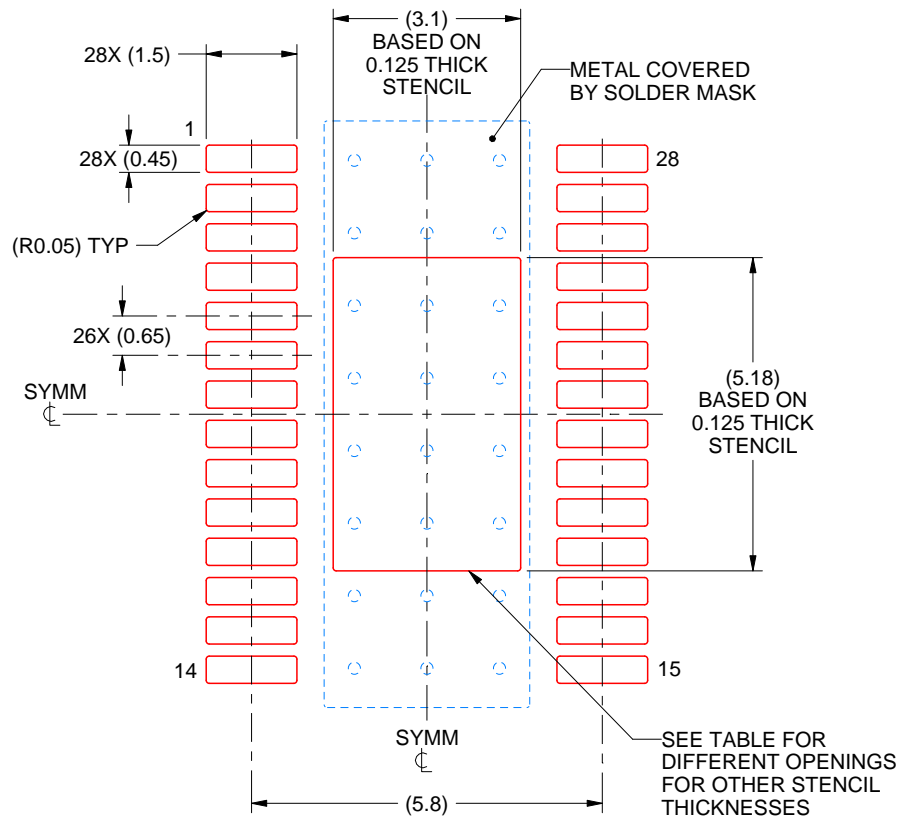

**SOLDER PASTE EXAMPLE**  
 BASED ON 0.125 mm THICK STENCIL  
 SCALE: 8X

STENCIL THICKNESS	SOLDER STENCIL OPENING
0.1	3.47 X 5.79
0.125	3.10 X 5.18 (SHOWN)
0.15	2.83 X 4.73
0.175	2.62 X 4.38

4223582/A 03/2017

NOTES: (continued)

11. Laser cutting apertures with trapezoidal walls and rounded corners may offer better paste release. IPC-7525 may have alternate design recommendations.
12. Board assembly site may have different recommendations for stencil design.

## 重要声明和免责声明

TI 均以“原样”提供技术性及其可靠性数据（包括数据表）、设计资源（包括参考设计）、应用或其他设计建议、网络工具、安全信息和其他资源，不保证其中不含任何瑕疵，且不做任何明示或暗示的担保，包括但不限于对适销性、适合某特定用途或不侵犯任何第三方知识产权的暗示担保。

所述资源可供专业开发人员应用TI 产品进行设计使用。您将对以下行为独自承担全部责任：(1) 针对您的应用选择合适的TI 产品；(2) 设计、验证并测试您的应用；(3) 确保您的应用满足相应标准以及任何其他安全、安保或其他要求。所述资源如有变更，恕不另行通知。TI 对您使用所述资源的授权仅限于开发资源所涉及TI 产品的相关应用。除此之外不得复制或展示所述资源，也不提供其它TI 或任何第三方的知识产权授权许可。如因使用所述资源而产生任何索赔、赔偿、成本、损失及债务等，TI 对此概不负责，并且您须赔偿由此对TI 及其代表造成的损害。

TI 所提供产品均受TI 的销售条款 (<http://www.ti.com.cn/zh-cn/legal/termsofsale.html>) 以及 [ti.com.cn](http://www.ti.com.cn) 上或随附TI 产品提供的其他可适用条款的约束。TI 提供所述资源并不扩展或以其他方式更改TI 针对TI 产品所发布的可适用的担保范围或担保免责声明。

邮寄地址：上海市浦东新区世纪大道 1568 号中建大厦 32 楼，邮政编码：200122

Copyright © 2020 德州仪器半导体技术（上海）有限公司