

## LM5575-Q1 75V、1.5A 降压开关稳压器

### 1 特性

- 符合面向汽车应用的 AEC-Q100 标准：
  - 器件温度等级 1:  $-40^{\circ}\text{C}$  至  $+125^{\circ}\text{C}$  的工作温度范围
  - 器件温度等级 0:  $-40^{\circ}\text{C}$  至  $+150^{\circ}\text{C}$  的工作温度范围
  - 器件 HBM ESD 分类等级 2
- 集成 75V、 $330\text{m}\Omega$  N 沟道 MOSFET
- 6V 至 75V 超宽输入电压范围
- 低至 1.225V 的可调节输出电压
- 1.65% 反馈基准电压精度
- 可使用单个电阻器在 50kHz 与 500kHz 之间调节工作频率
- 主/从频率同步
- 可调节软启动
- 仿真电流模式控制架构
- 宽带宽误差放大器
- 内置保护
- 使用 LM5575-Q1 并借助 WEBENCH<sup>®</sup> 电源设计器创建定制设计

### 2 应用

- 汽车
- 工业

### 3 说明

LM5575-Q1 降压开关稳压器简单易用，可支持设计工程师使用最少数量的组件来设计和优化强大的电源。LM5575-Q1 具有 6V 至 75V 的工作输入电压范围，并通过一个集成式  $330\text{m}\Omega$  N 沟道 MOSFET 提供 1.5A 的连续输出电流。该稳压器采用仿真电流模式架构，可提供固有的线路稳定性、出色的负载瞬态响应以及简化的环路补偿特性，且无电流模式稳压器中常见的低占空比限制。该器件的工作频率可在 50kHz 至 500kHz 范围内进行调节，从而实现解决方案尺寸和效率的最优化。LM5575-Q1 的逐周期电流限制、短路保护、热关断及远程关断等特性可确保其运行稳健可靠。该器件采用功耗增强型 16 引脚 HTSSOP 封装，并且配有用于散热的裸露芯片连接焊盘。LM5575-Q1 由一整套的 WEBENCH<sup>®</sup> 在线设计工具提供支持。如需了解符合 AEC-Q100 的等级 1 和等级 0 的可订购部件号，请参阅本数据表末尾的可订购产品附录。

#### 器件信息<sup>(1)</sup>

器件型号	封装	封装尺寸 (标称值)
LM5575-Q1	HTSSOP (16)	5.00mm x 4.40mm

(1) 如需了解所有可用封装，请参阅数据表末尾的可订购产品附录。

简化原理图

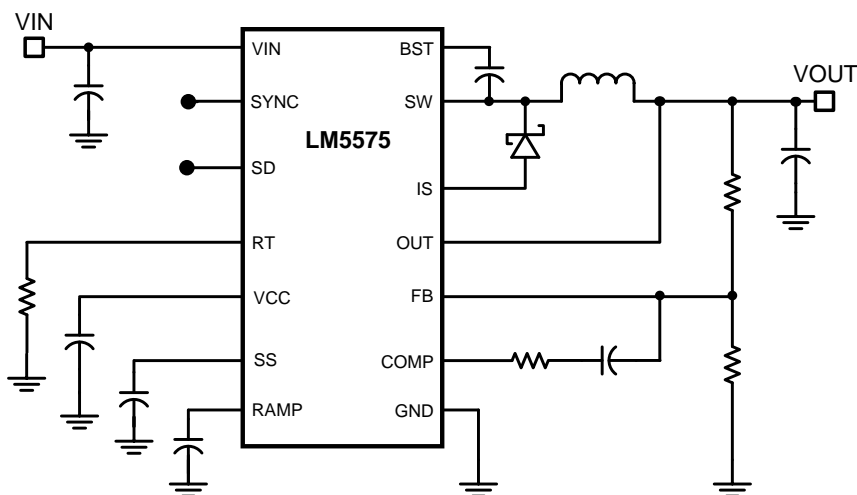

## 目录

<b>1</b>	<b>特性</b> .....	<b>1</b>	<b>8</b>	<b>Application and Implementation</b> .....	<b>16</b>
<b>2</b>	<b>应用</b> .....	<b>1</b>	8.1	Application Information.....	16
<b>3</b>	<b>说明</b> .....	<b>1</b>	8.2	Typical Application .....	17
<b>4</b>	<b>修订历史记录</b> .....	<b>2</b>	<b>9</b>	<b>Power Supply Recommendations</b> .....	<b>23</b>
<b>5</b>	<b>Pin Configuration and Functions</b> .....	<b>3</b>	<b>10</b>	<b>Layout</b> .....	<b>23</b>
<b>6</b>	<b>Specifications</b> .....	<b>4</b>	10.1	Layout Guidelines .....	23
6.1	Absolute Maximum Ratings .....	4	10.2	Layout Examples.....	24
6.2	ESD Ratings .....	4	10.3	Thermal Considerations .....	25
6.3	Recommended Operating Conditions.....	4	<b>11</b>	<b>器件和文档支持</b> .....	<b>25</b>
6.4	Thermal Information .....	5	11.1	器件支持 .....	25
6.5	Electrical Characteristics.....	5	11.2	接收文档更新通知 .....	25
6.6	Typical Characteristics .....	7	11.3	社区资源.....	25
<b>7</b>	<b>Detailed Description</b> .....	<b>9</b>	11.4	商标.....	25
7.1	Overview .....	9	11.5	静电放电警告.....	26
7.2	Functional Block Diagram .....	9	11.6	Glossary .....	26
7.3	Feature Description.....	9	<b>12</b>	<b>机械、封装和可订购信息</b> .....	<b>26</b>
7.4	Device Functional Modes.....	10			

## 4 修订历史记录

注：之前版本的页码可能与当前版本有所不同。

<b>Changes from Revision E (February 2019) to Revision F</b>	<b>Page</b>
• 在“特性”中添加了“等级 0”信息 .....	1
• 在“说明”末尾添加了等级 1 和等级 0 的句子 .....	1

<b>Changes from Revision D (March 2018) to Revision E</b>	<b>Page</b>
• 从数据表中删除了 LM2xxx 器件引用 .....	1
• Changed "760" mΩ to "800 mΩ" in buck switch Rds(on) over full operating junction temperature row .....	6
• Changed forced off-time maximum value from: 590 ns to: 626 ns in full operating junction temperature range.....	6

<b>Changes from Revision C (December 2014) to Revision D</b>	<b>Page</b>
• 已添加 添加了 WEBENCH 链接；对 SEO 改进进行了细微的编辑性更新.....	1
• Changed R <sub>θJA</sub> from "50°C/W" to "38.4°C/W" .....	5
• Changed R <sub>θJC(top)</sub> from "14°C/W" to "21.8°C/W"; add additional thermal values .....	5
• Corrected unit for RL to "kΩ" .....	8

<b>Changes from Revision B (April 2013) to Revision C</b>	<b>Page</b>
• 已添加 添加了引脚配置和功能 部分、处理额定值表、特性说明 部分、器件功能模式、应用和实施 部分、电源推荐部分、布局 部分、器件和文档支持 部分以及机械、封装和可订购信息 部分 .....	1

<b>Changes from Revision A (April 2013) to Revision B</b>	<b>Page</b>
• Changed layout of National Semiconductor data sheet to TI format.....	25

## 5 Pin Configuration and Functions

**PWP Package**  
**16-Pin HTSSOP With Exposed Thermal Pad**  
**Top View**

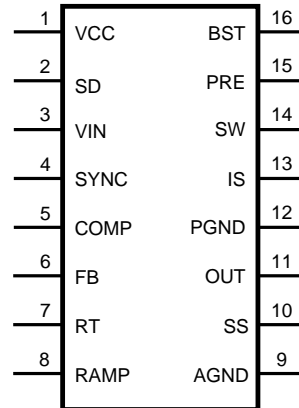

### Pin Functions

PIN		I/O	DESCRIPTION	APPLICATION INFORMATION
NO.	NAME			
1	VCC	O	Output of the bias regulator	VCC tracks VIN up to 9 V. Beyond 9 V, VCC is regulated to 7 V. A 0.1- $\mu$ F to 1- $\mu$ F ceramic decoupling capacitor is required. An external voltage (7.5 V – 14 V) can be applied to this pin to reduce internal power dissipation.
2	SD	I	Shutdown or UVLO input	If the SD pin voltage is lower than 0.7 V, the regulator is in a low power state. If the SD pin voltage is between 0.7 V and 1.225 V the regulator is in standby mode. If the SD pin voltage is higher than 1.225 V, the regulator is operational. An external voltage divider can be used to set a line undervoltage shutdown threshold. If the SD pin is left open circuit, a 5- $\mu$ A pullup current source configures the regulator fully operational.
3	VIN	I	Input supply voltage	Nominal operating range: 6 V to 75 V.
4	SYNC	I	Oscillator synchronization input or output	The internal oscillator can be synchronized to an external clock with an external pulldown device. Multiple LM5575-Q1 devices can be synchronized together by connection of their SYNC pins.
5	COMP	O	Output of the internal error amplifier	The loop compensation network must be connected between this pin and the FB pin.
6	FB	I	Feedback signal from the regulated output	This pin is connected to the inverting input of the internal error amplifier. The regulation threshold is 1.225 V.
7	RT	I	Internal oscillator frequency set input	The internal oscillator is set with a single resistor connected between this pin and the AGND pin.
8	RAMP	O	Ramp control signal	An external capacitor connected between this pin and the AGND pin sets the ramp slope used for current mode control. Recommended capacitor range 50 pF to 2000 pF.
9	AGND	GND	Analog ground	Internal reference for the regulator control functions
10	SS	O	Soft start	An external capacitor and an internal 10- $\mu$ A current source set the time constant for the rise of the error amp reference. The SS pin is held low during standby, VCC UVLO, and thermal shutdown.
11	OUT	O	Output voltage connection	Connect directly to the regulated output voltage.
12	PGND	GND	Power ground	Low-side reference for the PRE switch and the IS sense resistor.
13	IS	I	Current sense	Current measurement connection for the re-circulating diode. An internal sense resistor and a sample and hold circuit sense the diode current near the conclusion of the off-time. This current measurement provides the DC level of the emulated current ramp.
14	SW	O	Switching node	The source terminal of the internal buck switch. Connect the SW pin to the external Schottky diode and to the buck inductor.

**Pin Functions (continued)**

PIN		I/O	DESCRIPTION	APPLICATION INFORMATION
NO.	NAME			
15	PRE	O	Pre-charge assist for the bootstrap capacitor	This open-drain output can be connected to SW pin to help charging the bootstrap capacitor during very light load conditions or in applications where the output may be pre-charged before the LM5575-Q1 is enabled. An internal pre-charge MOSFET is turned on for 250 ns each cycle just prior to the on-time interval of the buck switch.
16	BST	I	Boost input for bootstrap capacitor	An external capacitor is required between the BST and the SW pins. TI recommends a 0.022- $\mu$ F ceramic capacitor. The capacitor is charged from VCC through an internal diode during the off-time of the buck switch.
NA	EP	--	Exposed Pad	Exposed metal pad on the underside of the device. TI recommends to connect this pad to the PWB ground plane to help with heat dissipation.

## 6 Specifications

### 6.1 Absolute Maximum Ratings

over operating free-air temperature range (unless otherwise noted)<sup>(1)(2)</sup>.

	MIN	MAX	UNIT
$V_{IN}$ to GND		76	V
BST to GND		90	V
PRE to GND		76	V
SW to GND (steady-state)		-1.5	V
BST to $V_{CC}$		76	V
SD, $V_{CC}$ to GND		14	V
BST to SW		14	V
OUT to GND		Limited to $V_{IN}$	
SYNC, SS, FB, RAMP to GND		7	V
Storage temperature, $T_{stg}$	-65	150	$^{\circ}$ C

- (1) **Absolute Maximum Ratings** are limits beyond which damage to the device may occur. **Recommended Operating Conditions** are conditions under which operation of the device is intended to be functional. For ensured specifications and test conditions, see the **Electrical Characteristics**.
- (2) If Military/Aerospace specified devices are required, contact the Texas Instruments Sales Office/ Distributors for availability and specifications.

### 6.2 ESD Ratings

	VALUE	UNIT
$V_{(ESD)}$ Electrostatic discharge Human-body model (HBM), per AEC Q100-002 <sup>(1)</sup>	$\pm$ 2000	V

- (1) AEC Q100-002 indicates that HBM stressing shall be in accordance with the ANSI/ESDA/JEDEC JS-001 specification.

### 6.3 Recommended Operating Conditions

over operating free-air temperature range (unless otherwise noted)<sup>(1)</sup>

	MIN	MAX	UNIT
$V_{IN}$	6	75	V
Operation junction temperature	-40	150	$^{\circ}$ C

- (1) **Absolute Maximum Ratings** are limits beyond which damage to the device may occur. **Recommended Operating Conditions** are conditions under which operation of the device is intended to be functional. For ensured specifications and test conditions, see the **Electrical Characteristics**.

## 6.4 Thermal Information

THERMAL METRIC <sup>(1)</sup>		LM5575-Q1	UNIT
		PWP (HTSSOP)	
		16 PINS	
R <sub>θJA</sub>	Junction-to-ambient thermal resistance	38.4	°C/W
R <sub>θJC(top)</sub>	Junction-to-case (top) thermal resistance	21.8	°C/W
R <sub>θJB</sub>	Junction-to-board thermal resistance	15.6	°C/W
ψ <sub>JT</sub>	Junction-to-top characterization parameter	0.5	°C/W
ψ <sub>JB</sub>	Junction-to-board characterization parameter	16.4	°C/W
R <sub>θJC(bot)</sub>	Junction-to-case (bottom) thermal resistance	1.5	°C/W

(1) For more information about traditional and new thermal metrics, see the [Semiconductor and IC Package Thermal Metrics](#) application report.

## 6.5 Electrical Characteristics

Specifications are for T<sub>J</sub> = 25°C. V<sub>IN</sub> = 48 V, R<sub>T</sub> = 32.4 kΩ unless otherwise stated. <sup>(1)</sup>

PARAMETER		TEST CONDITIONS	MIN	TYP	MAX	UNIT
<b>START-UP REGULATOR</b>						
V <sub>CCReg</sub>	V <sub>CC</sub> regulator output			7.15		V
		Over full operating junction temperature range	6.85		7.5	
	V <sub>CC</sub> LDO mode turnoff			9		V
	V <sub>CC</sub> current limit	V <sub>CC</sub> = 0 V		25		mA
<b>VCC SUPPLY</b>						
	V <sub>CC</sub> UVLO threshold	(V <sub>CC</sub> increasing)		5.35		V
		Over full operating junction temperature range	5.01		5.69	
	V <sub>CC</sub> undervoltage hysteresis			0.35		V
	Bias current (lin)	FB = 1.3 V		3.7		mA
		Over full operating junction temperature range			4.5	
	Shutdown current (lin)	SD = 0 V		57		μA
		Over full operating junction temperature range			85	
<b>SHUTDOWN THRESHOLDS</b>						
	Shutdown threshold	(SD Increasing)		0.7		V
		Over full operating junction temperature range	0.43		0.9	
	Shutdown hysteresis			0.1		V
	Standby threshold	(Standby Increasing)		1.225		V
		Over full operating junction temperature range	1.15		1.30	
	Standby hysteresis			0.1		V
	SD pullup current source			5		μA

(1) Minimum and maximum limits are 100% production tested at 25°C. Limits over the operating temperature range are ensured through correlation using Statistical Quality Control (SQC) methods. Limits are used to calculate Average Outgoing Quality Level (AOQL).

**Electrical Characteristics (continued)**

 Specifications are for  $T_J = 25^\circ\text{C}$ .  $V_{IN} = 48\text{ V}$ ,  $R_T = 32.4\text{ k}\Omega$  unless otherwise stated. <sup>(1)</sup>

PARAMETER		TEST CONDITIONS	MIN	TYP	MAX	UNIT
<b>SWITCH CHARACTERISTICS</b>						
	Buck switch Rds(on)			330		mΩ
		Over full operating junction temperature range			800	
	BOOST UVLO			4		V
	BOOST UVLO hysteresis			0.56		V
	Pre-charge switch Rds(on)			70		Ω
	Pre-charge switch on-time			250		ns
<b>CURRENT LIMIT</b>						
	Cycle by cycle current limit	RAMP = 0 V		2.1		A
		Over full operating junction temperature range	1.8		2.7	
	Cycle by cycle current limit delay	RAMP = 2.5 V		85		ns
<b>SOFT START</b>						
	SS current source			10		μA
		Over full operating junction temperature range	7		14	
<b>OSCILLATOR</b>						
	Frequency1			200		kHz
		Over full operating junction temperature range	180		220	
	Frequency2	$R_T = 11\text{ k}\Omega$		485		kHz
		Over full operating junction temperature range	425		545	
	SYNC source impedance			11		kΩ
	SYNC sink impedance			110		Ω
	SYNC threshold (falling)			1.3		V
	SYNC frequency	$R_T = 11\text{ k}\Omega$				kHz
		Over full operating junction temperature range	550			
	SYNC pulse width minimum	Over full operating junction temperature range	15			ns
<b>RAMP GENERATOR</b>						
	Ramp current 1	$V_{IN} = 60\text{ V}$ , $V_{OUT} = 10\text{ V}$		550		μA
		Over full operating junction temperature range	467		633	
	Ramp current 2	$V_{IN} = 10\text{ V}$ , $V_{OUT} = 10\text{ V}$		50		μA
		Over full operating junction temperature range	36		64	
<b>PWM COMPARATOR</b>						
	Forced off-time			500		ns
		Over full operating junction temperature range	390		626	
	Minimum on-time			80		ns
	COMP to PWM comparator offset			0.7		V

## Electrical Characteristics (continued)

Specifications are for  $T_J = 25^\circ\text{C}$ .  $V_{IN} = 48\text{ V}$ ,  $R_T = 32.4\text{ k}\Omega$  unless otherwise stated. <sup>(1)</sup>

PARAMETER		TEST CONDITIONS	MIN	TYP	MAX	UNIT
<b>ERROR AMPLIFIER</b>						
	Feedback voltage	$V_{FB} = \text{COMP}$		1.225		V
		Over full operating junction temperature range	1.205		1.245	
	FB bias current			17		nA
	DC gain			70		dB
	COMP sink / source current	Over full operating junction temperature range	2.5			mA
	Unity gain bandwidth			3		MHz
<b>DIODE SENSE RESISTANCE</b>						
$D_{\text{SENSE}}$				83		m $\Omega$
<b>THERMAL SHUTDOWN</b>						
$T_{\text{SD}}$	Thermal shutdown threshold			180		$^\circ\text{C}$
	Thermal shutdown hysteresis			25		$^\circ\text{C}$

## 6.6 Typical Characteristics

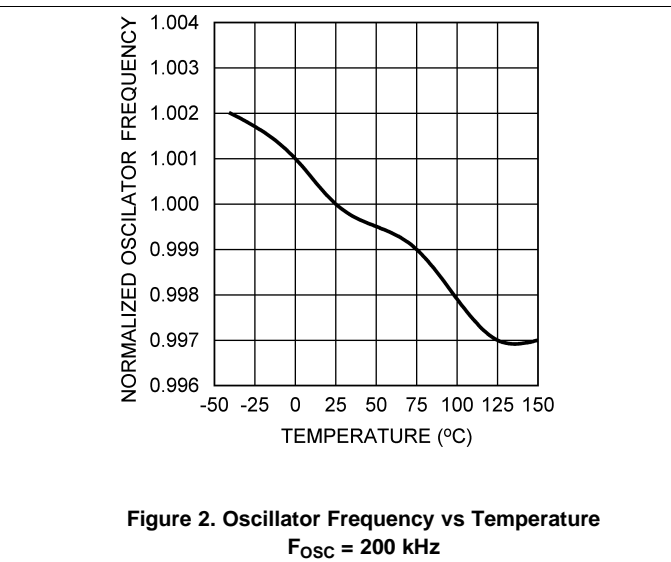
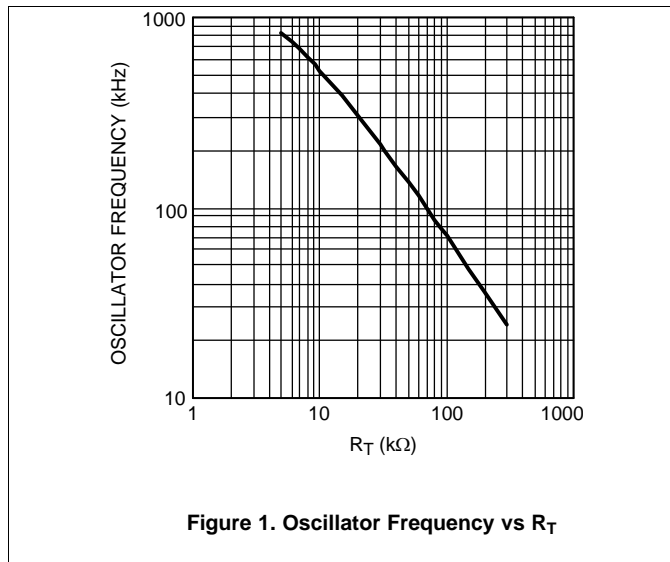

Typical Characteristics (continued)

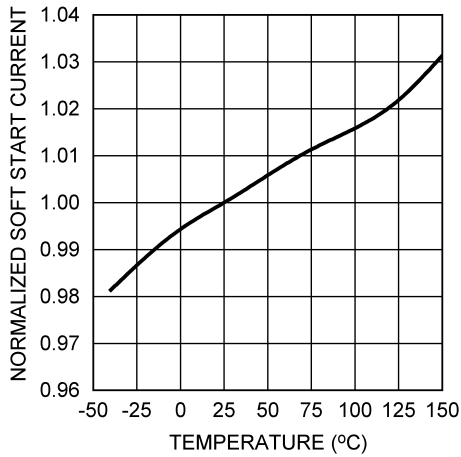

Figure 3. Soft-Start Current vs Temperature

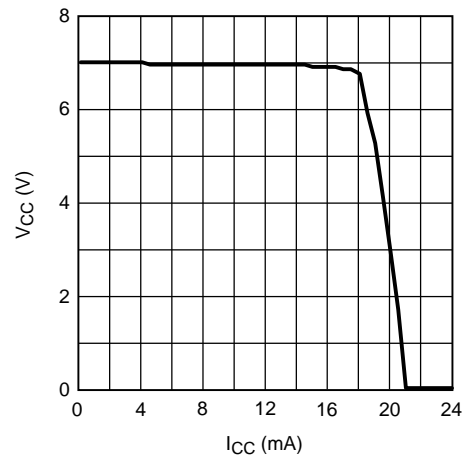

Figure 4. VCC vs ICC VIN = 12 V

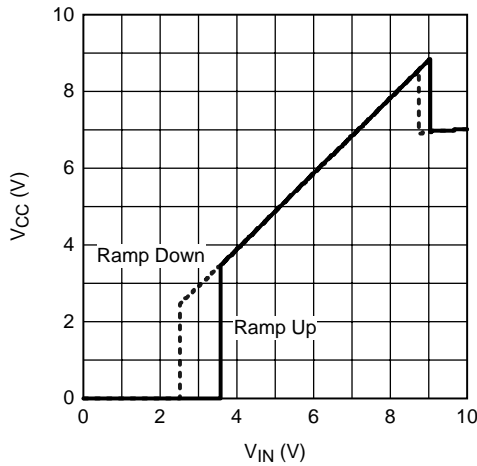

Figure 5. VCC vs VIN RL = 7 kΩ

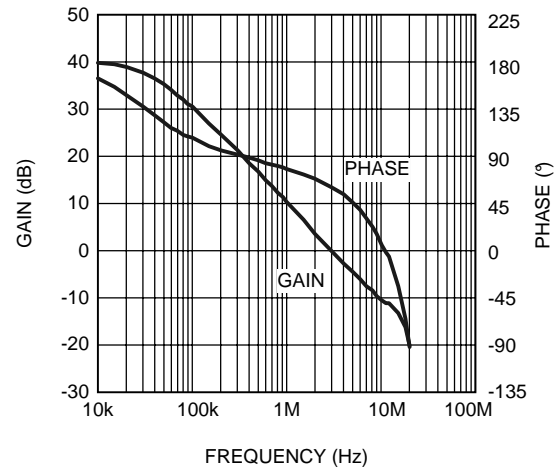

Figure 6. Error Amplifier Gain / Phase AVCL = 101

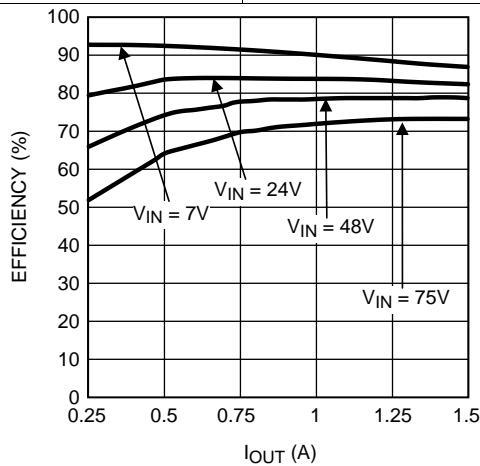

Figure 7. Demoboard Efficiency vs IOUT and VIN



## 7 Detailed Description

### 7.1 Overview

The LM5575-Q1 switching regulator features the functions necessary to implement an efficient high-voltage buck regulator using a minimum of external components. This easy-to-use regulator integrates a 75-V N-Channel buck switch with an output current capability of 1.5 amps. The regulator control method is based on current mode control using an emulated current ramp. Peak current mode control provides inherent line voltage feed-forward, cycle-by-cycle current limiting, and ease-of-loop compensation. The use of an emulated control ramp reduces noise sensitivity of the pulse-width modulation circuit, which allows reliable processing of very small duty cycles necessary in high-input voltage applications. The operating frequency is user programmable from 50 kHz to 500 kHz. An oscillator synchronization pin allows multiple LM5575-Q1 regulators to self-synchronize or be synchronized to an external clock. The output voltage can be set as low as 1.225 V. Fault protection features include, current limiting, thermal shutdown, and remote shutdown capability. The device is available in the 16-pin HTSSOP package that features an exposed pad to help thermal dissipation.

### 7.2 Functional Block Diagram

The LM5575-Q1 device can be applied in numerous applications to efficiently step down a high, unregulated input voltage. The device is designed for telecom, industrial, and automotive power bus voltage ranges.

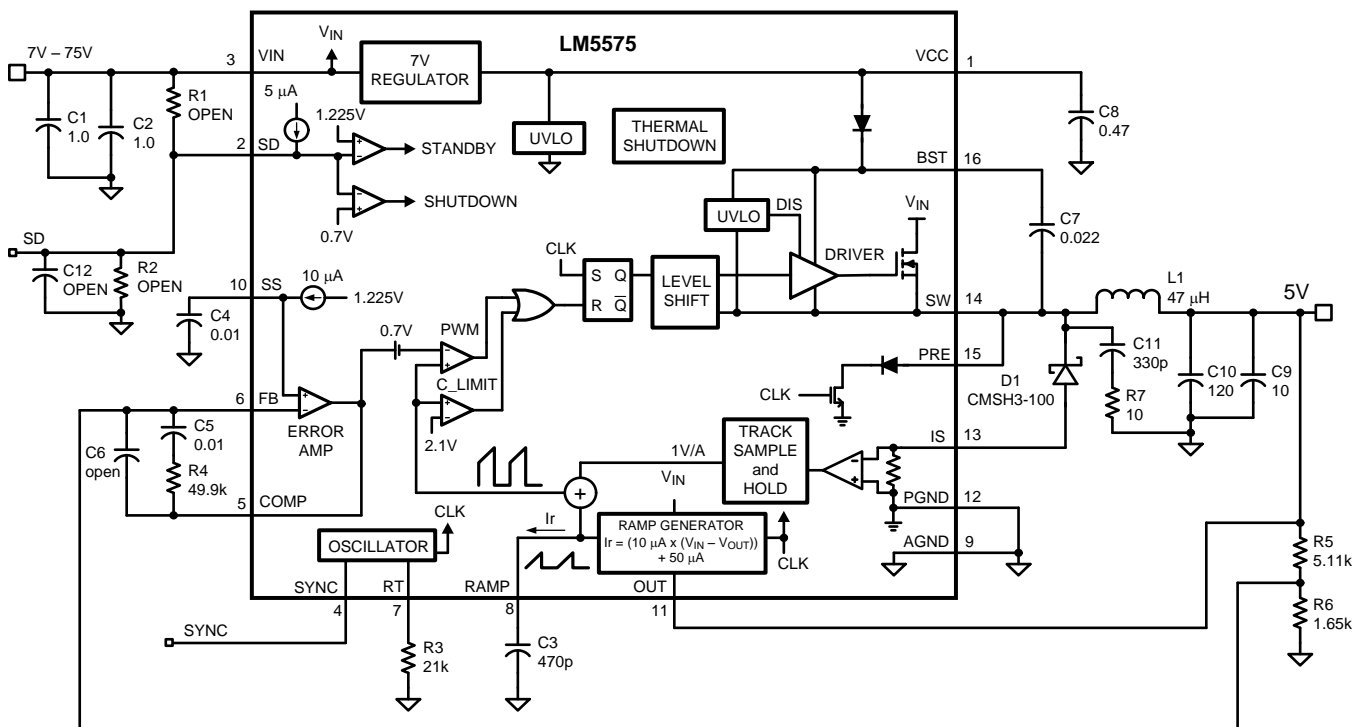

### 7.3 Feature Description

#### 7.3.1 Shutdown and Standby

The LM5575-Q1 contains a dual-level shutdown (SD) circuit. When the SD pin voltage is below 0.7 V, the regulator is in a low-current shutdown mode. When the SD pin voltage is greater than 0.7 V but less than 1.225 V, the regulator is in standby mode. In standby mode, the  $V_{CC}$  regulator is active but the output switch is disabled. When the SD pin voltage exceeds 1.225 V, the output switch is enabled and normal operation begins. An internal 5- $\mu$ A pullup current configures the regulator to be fully operational if the SD pin is left open.

## Feature Description (continued)

An external set-point voltage divider from VIN to GND can be used to set the operational input range of the regulator. The divider must be designed such that the voltage at the SD pin is greater than 1.225 V when VIN is in the desired operating range. The internal 5- $\mu$ A pullup current source must be included in calculations of the external set-point divider. Hysteresis of 0.1 V is included for both the shutdown and standby thresholds. The SD pin is internally clamped with a 1-k $\Omega$  resistor and an 8-V Zener clamp. The voltage at the SD pin should never exceed 14 V. If the voltage at the SD pin exceeds 8 V, the bias current increase at a rate of 1 mA/V.

The SD pin can also be used to implement various remote enable and disable functions. Pulling the SD pin below the 0.7-V threshold totally disables the controller. If the SD pin voltage is higher than 1.225 V, the regulator is operational.

### 7.3.2 Current Limit

The LM5575-Q1 contains a unique current monitoring scheme for control and overcurrent protection. When set correctly, the emulated current sense signal provides a signal which is proportional to the buck switch current with a scale factor of 1 V/A. The emulated ramp signal is applied to the current limit comparator. If the emulated ramp signal exceeds 2.1 V (2.1 A), the present current cycle is terminated (cycle-by-cycle current limiting). In applications with small output inductance and high-input voltage, the switch current may overshoot due to the propagation delay of the current limit comparator. If an overshoot should occur, the diode current sampling circuit will detect the excess inductor current during the off-time of the buck switch. If the sample and hold DC level exceeds the 2.1-V current limit threshold, the buck switch will be disabled and skip pulses until the diode current sampling circuit detects the inductor current has decayed below the current limit threshold. This approach prevents current runaway conditions due to propagation delays or inductor saturation because the inductor current is forced to decay following the current overshoot.

### 7.3.3 Soft Start

The soft-start feature allows the regulator to gradually reach the initial steady-state operating point, thus reducing start-up stresses and surges. The internal soft-start current source, set to 10  $\mu$ A, gradually increases the voltage of an external soft-start capacitor connected to the SS pin. The soft-start capacitor voltage is connected to the reference input of the error amplifier. Various sequencing and tracking schemes can be implemented using external circuits that limit or clamp the voltage level of the SS pin.

In the event a fault is detected (overtemperature, Vcc UVLO, SD) the soft-start capacitor will be discharged. When the fault condition is no longer present, a new soft-start sequence will commence.

### 7.3.4 Thermal Protection

Internal Thermal Shutdown circuitry is provided to protect the integrated circuit in the event the maximum junction temperature is exceeded. When activated (typically at 180°C), the controller is forced into a low-power reset state, which disables the output driver and the bias regulator. This feature is provided to prevent catastrophic failures from accidental device overheating.

## 7.4 Device Functional Modes

### 7.4.1 High-Voltage Start-Up Regulator

The LM5575-Q1 contains a dual-mode internal high-voltage start-up regulator that provides the V<sub>CC</sub> bias supply for the PWM controller and bootstrap MOSFET gate driver. The input pin (VIN) can be connected directly to the input voltage, as high as 75 V. For input voltages lower than 9 V, a low dropout switch connects V<sub>CC</sub> directly to VIN. In this supply range, V<sub>CC</sub> is approximately equal to V<sub>IN</sub>. For V<sub>IN</sub> voltage greater than 9 V, the low-dropout switch is disabled and the V<sub>CC</sub> regulator is enabled to maintain V<sub>CC</sub> at approximately 7 V. The wide operating range of 6 V to 75 V is achieved through the use of this dual-mode regulator.

The output of the V<sub>CC</sub> regulator is current-limited to 25 mA. Upon power up, the regulator sources current into the capacitor connected to the V<sub>CC</sub> pin. When the voltage at the V<sub>CC</sub> pin exceeds the V<sub>CC</sub> UVLO threshold of 5.35 V and the SD pin is greater than 1.225 V, the output switch is enabled and a soft-start sequence begins. The output switch remains enabled until V<sub>CC</sub> falls below 5 V or the SD pin falls below 1.125 V.

### Device Functional Modes (continued)

An auxiliary supply voltage can be applied to the VCC pin to reduce the IC power dissipation. If the auxiliary voltage is greater than 7.3 V, the internal regulator essentially shuts off, reducing the IC power dissipation. The VCC regulator series pass transistor includes a diode between VCC and VIN that should not be forward biased in normal operation. Therefore the auxiliary VCC voltage should never exceed the VIN voltage.

In high-voltage applications, take care to ensure the VIN pin does not exceed the absolute maximum voltage rating of 76 V. During line or load transients, voltage ringing on the VIN line that exceeds the absolute maximum ratings can damage the IC. Both careful printed-circuit board layout and the use of quality bypass capacitors located close to the VIN and GND pins are essential.

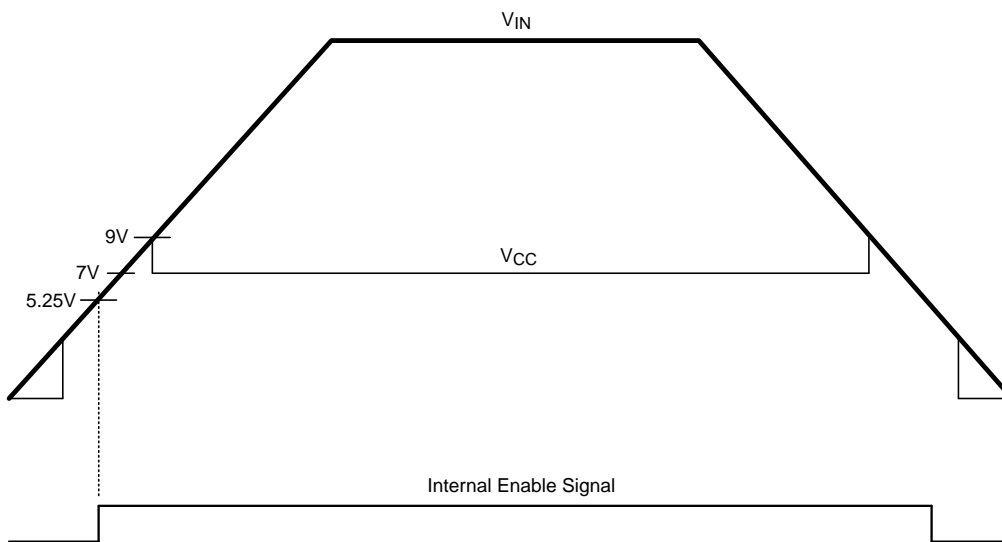

**Figure 8. VIN and VCC Sequencing**

#### 7.4.2 Oscillator and Sync Capability

The LM5575-Q1 oscillator frequency is set by a single external resistor connected between the RT pin and the AGND pin. Place the RT resistor very close to the device and connected directly to the pins of the IC (RT and AGND). To set a desired oscillator frequency (F), the necessary value for the RT resistor can be calculated by [Equation 1](#):

$$R_T = \frac{\frac{1}{F} - 580 \times 10^{-9}}{135 \times 10^{-12}} \tag{1}$$

The SYNC pin can be used to synchronize the internal oscillator to an external clock. The external clock must be of higher frequency than the free-running frequency set by the RT resistor. A clock circuit with an open-drain output is the recommended interface from the external clock to the SYNC pin. The clock pulse duration must be greater than 15 ns.

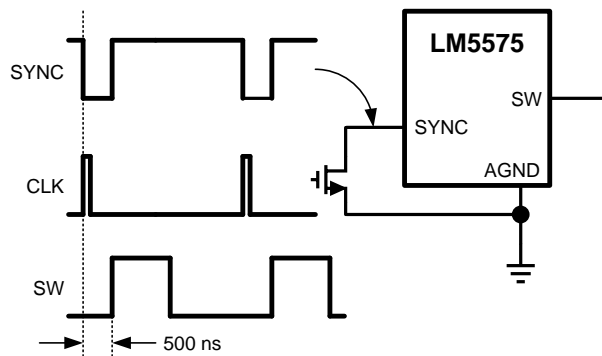
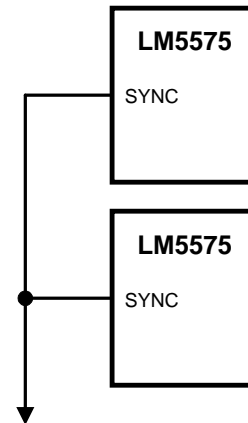
**Device Functional Modes (continued)**

**Figure 9. Sync From External Clock**

 UP TO 5 TOTAL  
DEVICES

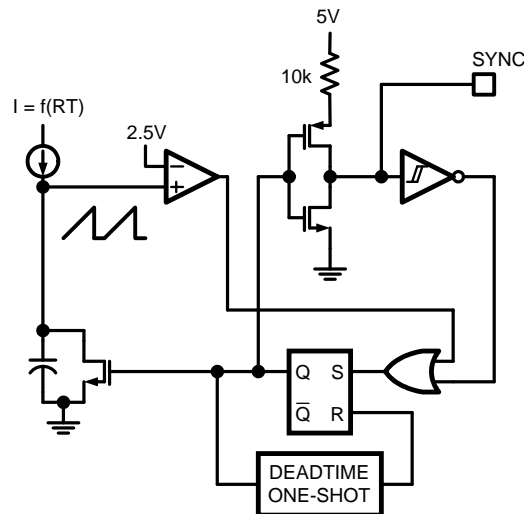
**Figure 10. Sync From Multiple Devices**

Multiple LM5575-Q1 devices can be synchronized together simply by connecting the SYNC pins together. In this configuration, all of the devices will be synchronized to the highest frequency device. The diagram in [Figure 11](#) shows the SYNC input and output features of the LM5575-Q1. The internal oscillator circuit drives the SYNC pin with a strong pulldown and weak pullup inverter. When the SYNC pin is pulled low either by the internal oscillator or an external clock, the ramp cycle of the oscillator is terminated and a new oscillator cycle begins. Thus, if the SYNC pins of several LM5575-Q1 ICs are connected together, the IC with the highest internal clock frequency pulls the connected SYNC pins low first and terminate the oscillator ramp cycles of the other ICs. The LM5575-Q1 with the highest programmed clock frequency will serve as the master and control the switching frequency of the all the devices with lower oscillator frequency.

**Figure 11. Simplified Oscillator Block Diagram and Sync I/O Circuit**
**7.4.3 Error Amplifier and PWM Comparator**

The internal high-gain error amplifier generates an error signal proportional to the difference between the regulated output voltage and an internal precision reference (1.225 V). The output of the error amplifier is connected to the COMP pin, which allows the user to provide loop compensation components, generally a type II network, as shown in [Functional Block Diagram](#). This network creates a pole at DC, a zero and a noise-reducing, high-frequency pole. The PWM comparator compares the emulated current sense signal from the RAMP generator to the error amplifier output voltage at the COMP pin.

## Device Functional Modes (continued)

### 7.4.4 Ramp Generator

The ramp signal used in the pulse-width modulator for current-mode control is typically derived directly from the buck switch current. This switch current corresponds to the positive slope portion of the output inductor current. Using this signal for the PWM ramp simplifies the control-loop-transfer function to a single pole response and provides inherent input voltage feed-forward compensation. The disadvantage of using the buck switch current signal for PWM control is the large leading edge spike due to circuit parasitics that must be filtered or blanked. Also, the current measurement may introduce significant propagation delays. The filtering, blanking time, and propagation delay limit the minimum achievable pulse width. In applications where the input voltage may be relatively large in comparison to the output voltage, controlling small pulse widths and duty cycles is necessary for regulation. The LM5575-Q1 uses a unique ramp generator, which does not actually measure the buck switch current but rather reconstructs the signal. Reconstructing or emulating the inductor current provides a ramp signal to the PWM comparator that is free of leading edge spikes and measurement or filtering delays. The current reconstruction is comprised of two elements; a sample and hold DC level and an emulated current ramp.

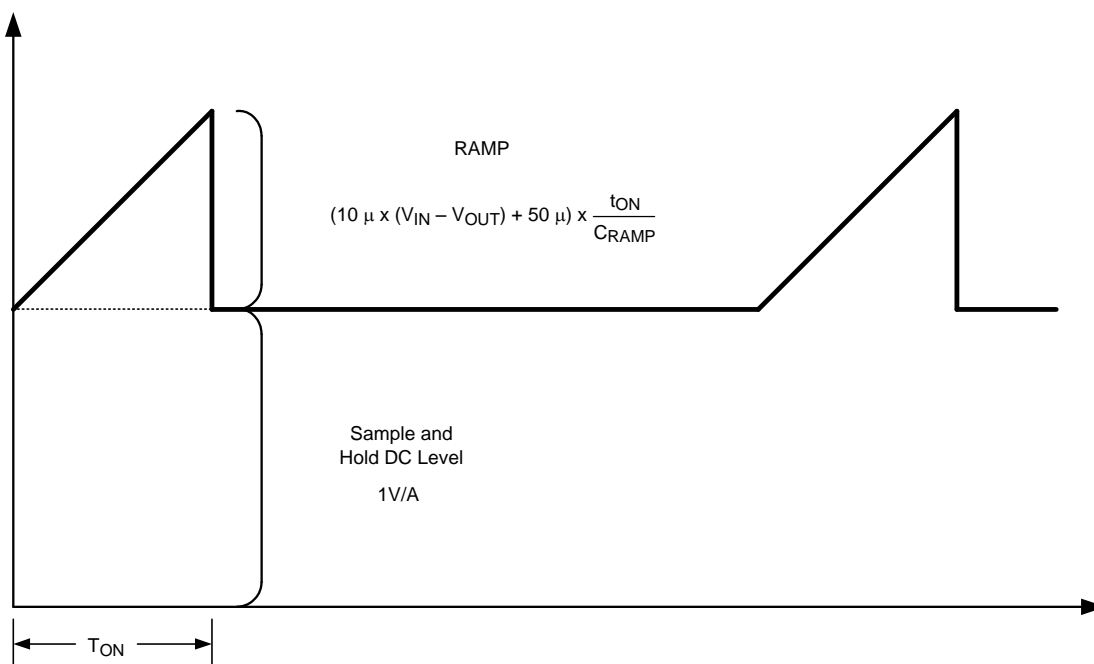

Figure 12. Composition of Current Sense Signal

The sample and hold DC level shown in Figure 12 is derived from a measurement of the re-circulating Schottky diode anode current. The re-circulating diode anode should be connected to the IS pin. The diode current flows through an internal current sense resistor between the IS and PGND pins. The voltage level across the sense resistor is sampled and held just prior to the onset of the next conduction interval of the buck switch. The diode current sensing and sample and hold provide the DC level of the reconstructed current signal. The positive slope inductor current ramp is emulated by an external capacitor connected from the RAMP pin to AGND and an internal voltage controlled current source. The ramp current source that emulates the inductor current is a function of the  $V_{IN}$  and  $V_{OUT}$  voltages per Equation 2:

$$I_{RAMP} = (10 \mu A \times (V_{IN} - V_{OUT})) + 50 \mu A \quad (2)$$

Proper selection of the RAMP capacitor depends upon the selected value of the output inductor. The value of  $C_{RAMP}$  can be selected from Equation 3:

$$C_{RAMP} = L \times 10^{-5}$$

where

- L is the value of the output inductor in Henrys (3)

## Device Functional Modes (continued)

With this value, the scale factor of the emulated current ramp is approximately equal to the scale factor of the DC level sample and hold (1 V/A). Locate the  $C_{RAMP}$  capacitor very close to the device and connect directly to the pins of the IC (RAMP and AGND).

For duty cycles greater than 50%, peak-current-mode control circuits are subject to sub-harmonic oscillation. Sub-harmonic oscillation is normally characterized by observing alternating wide and narrow pulses at the switch node. Add a fixed slope voltage ramp (slope compensation) to the current sense signal to prevent this oscillation. The 50  $\mu\text{A}$  of offset current provided from the emulated current source adds some fixed slope to the ramp signal. In some high-output voltage, high duty cycle applications, additional slope may be required. In these applications, a pullup resistor may be added between the  $V_{CC}$  and RAMP pins to increase the ramp slope compensation.

For  $V_{OUT} > 7.5\text{ V}$ :

Calculate optimal slope current,  $I_{OS} = V_{OUT} \times 10\ \mu\text{A/V}$ .

For example, at  $V_{OUT} = 10\text{ V}$ ,  $I_{OS} = 100\ \mu\text{A}$ .

Install a resistor from the RAMP pin to  $V_{CC}$ :

$$R_{RAMP} = V_{CC} / (I_{OS} - 50\ \mu\text{A}) \quad (4)$$

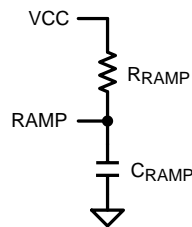

**Figure 13.  $R_{RAMP}$  to  $V_{CC}$  for  $V_{OUT} > 7.5\text{ V}$**

### 7.4.5 BOOST Pin

The LM5575-Q1 integrates an N-Channel buck switch and associated floating high-voltage level shift and gate driver. This gate-driver circuit works in conjunction with an internal diode and an external bootstrap capacitor. TI recommends a 0.022- $\mu\text{F}$  ceramic capacitor, connected with short traces between the BST pin and SW pin. During the off-time of the buck switch, the SW pin voltage is approximately  $-0.5\text{ V}$ , and the bootstrap capacitor is charged from  $V_{CC}$  through the internal bootstrap diode. When operating with a high PWM duty cycle, the buck switch is forced off each cycle for 500 ns to ensure that the bootstrap capacitor is recharged.

Under very light-load conditions or when the output voltage is pre-charged, the SW voltage does not remain low during the off-time of the buck switch. If the inductor current falls to zero and the SW pin rises, the bootstrap capacitor does not receive sufficient voltage to operate the buck switch gate driver. For these applications, the PRE pin can be connected to the SW pin to pre-charge the bootstrap capacitor. The internal pre-charge MOSFET and diode connected between the PRE pin and PGND turns on each cycle for 250 ns just prior to the onset of a new switching cycle. If the SW pin is at a normal negative voltage level (continuous conduction mode (CCM)), then no current flows through the pre-charge MOSFET/diode.

## Device Functional Modes (continued)

### 7.4.6 Maximum Duty Cycle and Input Dropout Voltage

There is a forced off-time of 500 ns implemented each cycle to ensure sufficient time for the diode current to be sampled. This forced off-time limits the maximum duty cycle of the buck switch. The maximum duty cycle varies with the operating frequency.

$$D_{\text{MAX}} = 1 - F_s \times 500 \text{ ns}$$

where

- $F_s$  is the oscillator frequency. (5)

Limiting the maximum duty cycle will raise the input dropout voltage. The input dropout voltage is the lowest input voltage required to maintain regulation of the output voltage. [Equation 6](#) calculates an approximation of the input dropout voltage.

$$V_{\text{in}_{\text{MIN}}} = \frac{V_{\text{out}} + V_D}{1 - F_s \times 500 \text{ ns}}$$

where

- $V_D$  is the voltage drop across the re-circulatory diode. (6)

Operating at high switching frequency raises the minimum input voltage necessary to maintain regulation.

## 8 Application and Implementation

### NOTE

Information in the following applications sections is not part of the TI component specification, and TI does not warrant its accuracy or completeness. TI's customers are responsible for determining suitability of components for their purposes. Customers should validate and test their design implementation to confirm system functionality.

### 8.1 Application Information

#### 8.1.1 Bias Power Dissipation Reduction

Buck regulators operating with high input voltage can dissipate an appreciable amount of power for the bias of the IC. The  $V_{CC}$  regulator must step down the input voltage  $V_{IN}$  to a nominal  $V_{CC}$  level of 7 V. The large voltage drop across the  $V_{CC}$  regulator translates into a large power dissipation within the  $V_{CC}$  regulator. There are several techniques that can significantly reduce this bias regulator power dissipation. Figure 14 and Figure 15 depict two methods to bias the IC from the output voltage. In each case, the internal  $V_{CC}$  regulator is used to initially bias the VCC pin. After the output voltage is established, the VCC pin potential is raised higher than the nominal 7-V regulation level, which effectively disables the internal  $V_{CC}$  regulator. The voltage applied to the VCC pin should never exceed 14 V. The  $V_{CC}$  voltage should never be larger than the  $V_{IN}$  voltage.

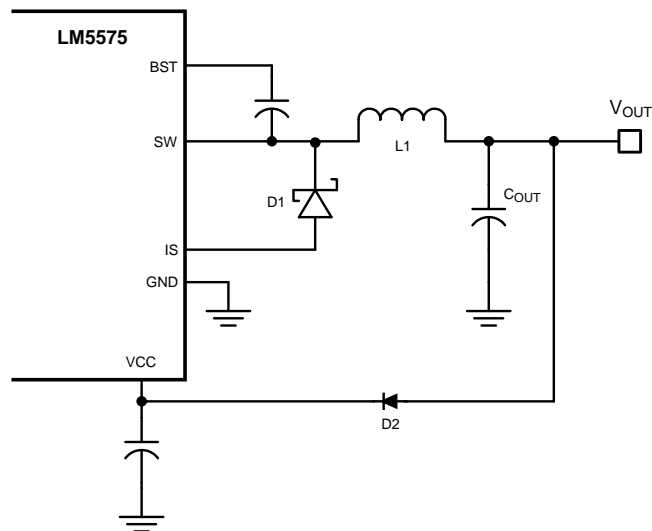

Figure 14.  $V_{CC}$  Bias From  $V_{OUT}$  for  $8\text{ V} < V_{OUT} < 14\text{ V}$

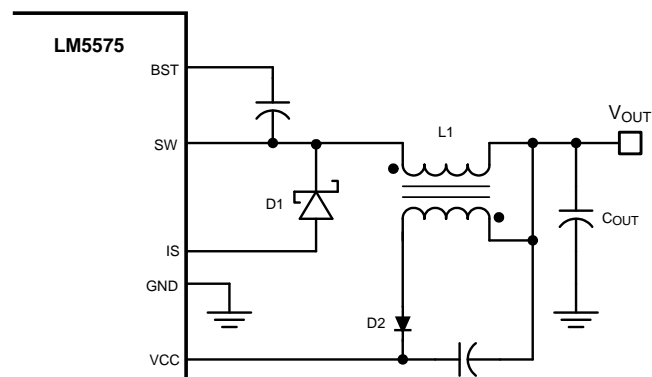

Figure 15.  $V_{CC}$  Bias With Additional Winding on the Output Inductor



## 8.2 Typical Application

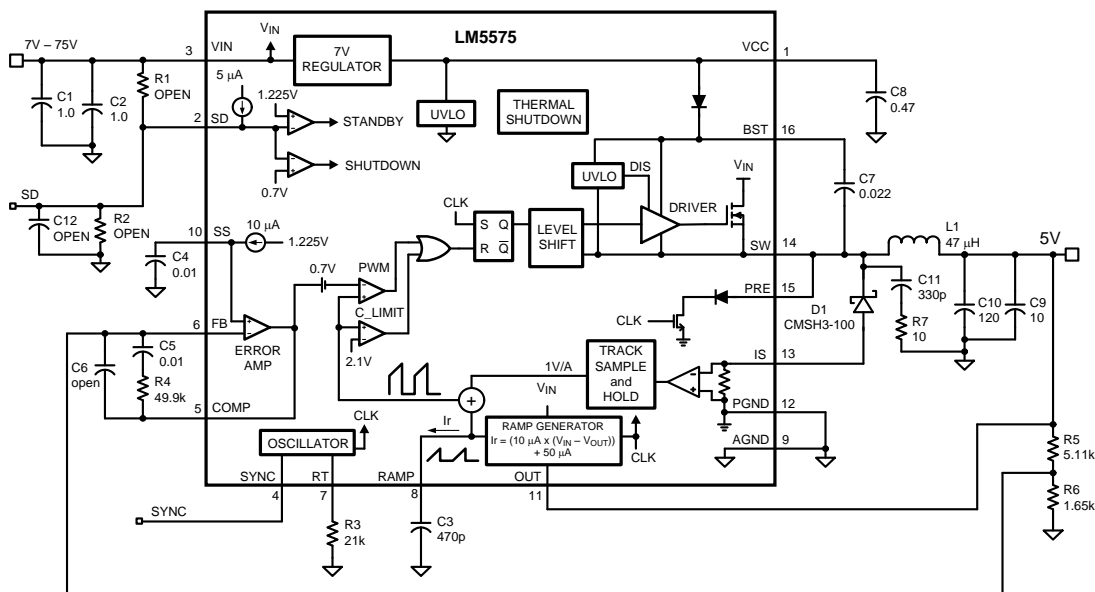

Figure 16. Typical Application Circuit

### 8.2.1 Design Requirements

The circuit shown in [Functional Block Diagram](#) is configured for the following specifications:

- $V_{OUT} = 5\text{ V}$
- $V_{IN} = 7\text{ V to }75\text{ V}$
- $F_s = 300\text{ kHz}$
- Minimum load current (for CCM) = 200 mA
- Maximum load current = 1.5 A

### 8.2.2 Detailed Design Procedure

#### 8.2.2.1 Custom Design With WEBENCH® Tools

[Click here](#) to create a custom design using the LM5575-Q1 device with the WEBENCH® Power Designer.

1. Start by entering the input voltage ( $V_{IN}$ ), output voltage ( $V_{OUT}$ ), and output current ( $I_{OUT}$ ) requirements.
2. Optimize the design for key parameters such as efficiency, footprint, and cost using the optimizer dial.
3. Compare the generated design with other possible solutions from Texas Instruments.

The WEBENCH Power Designer provides a customized schematic along with a list of materials with real-time pricing and component availability.

In most cases, these steps are available:

- Run electrical simulations to see important waveforms and circuit performance
- Run thermal simulations to understand board thermal performance
- Export customized schematic and layout into popular CAD formats
- Print PDF reports for the design, and share the design with colleagues

Get more information about WEBENCH tools at [www.ti.com/WBENCH](http://www.ti.com/WBENCH).

## Typical Application (continued)

### 8.2.2.2 External Components

The procedure for calculating the external components is illustrated with the following design example.

#### 8.2.2.3 R<sub>T</sub> (R<sub>T</sub>)

R<sub>T</sub> sets the oscillator switching frequency. Generally, higher-frequency applications are smaller but have higher losses. Operation at 300 kHz was selected for this example as a reasonable compromise for both small size and high efficiency. The value of R<sub>T</sub> for 300-kHz switching frequency can be calculated as Equation 7.

$$R_T = \frac{[(1 / 300 \times 10^3) - 580 \times 10^{-9}]}{135 \times 10^{-12}} \quad (7)$$

The nearest standard value of 21 kΩ was chosen for R<sub>T</sub>.

#### 8.2.2.4 L1

The inductor value is determined based on the operating frequency, load current, ripple current, and the minimum and maximum input voltage (V<sub>IN(min)</sub>, V<sub>IN(max)</sub>).

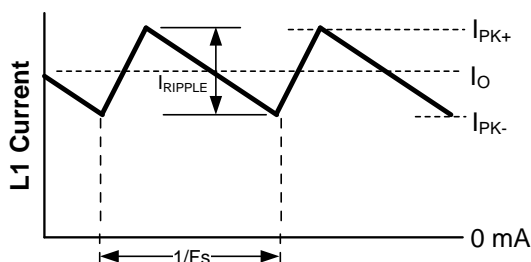

**Figure 17. Inductor Current Waveform**

To keep the circuit in CCM, the maximum ripple current I<sub>RIPPLE</sub> must be less than twice the minimum load current, or 0.4 A<sub>p-p</sub>. Using this value of ripple current, the value of inductor (L1) is calculated using Equation 8 and Equation 9:

$$L1 = \frac{V_{OUT} \times (V_{IN(max)} - V_{OUT})}{I_{RIPPLE} \times F_S \times V_{IN(max)}} \quad (8)$$

$$L1 = \frac{5V \times (75V - 5V)}{0.4A \times 300 \text{ kHz} \times 75V} = 39 \mu\text{H} \quad (9)$$

This procedure provides a guide to select the value of L1. The nearest standard value (47 μH) is used. L1 must be rated for the peak current (I<sub>PK+</sub>) to prevent saturation. During normal loading conditions, the peak current occurs at maximum load current plus maximum ripple. During an overload condition, the peak current is limited to 2.1 A nominal (2.5 A maximum). The selected inductor has a conservative 3.25-Amp saturation current rating. The saturation rating is defined by inductor manufacturers as the current necessary for the inductance to reduce by 30%, at 20°C.

#### 8.2.2.5 C3 (C<sub>RAMP</sub>)

With the inductor value selected, Equation 10 calculates the value of C3 (C<sub>RAMP</sub>) necessary for the emulation ramp circuit:

$$C_{RAMP} = L \times 10^{-5}$$

where

- L is in Henrys. (10)

With L1 selected for 47 μH, the recommended value for C3 is 470 pF.

## Typical Application (continued)

### 8.2.2.6 C9, C10

The output capacitors, C9 and C10, smooth the inductor ripple current and provide a source of charge for transient loading conditions. For this design a 10- $\mu\text{F}$  ceramic capacitor and a 120- $\mu\text{F}$  AL organic capacitor were selected. The ceramic capacitor provides ultra-low ESR to reduce the output ripple voltage and noise spikes, while the AL capacitor provides a large bulk capacitance in a small volume for transient loading conditions. Equation 11 calculates an approximation for the output ripple voltage.

$$\Delta V_{\text{OUT}} = \Delta I_L \times \left( \text{ESR} + \frac{1}{8 \times F_S \times C_{\text{OUT}}} \right) \quad (11)$$

### 8.2.2.7 D1

A Schottky type re-circulating diode is required for all LM5575-Q1 applications. Ultra-fast diodes are not recommended and may result in damage to the IC due to reverse recovery current transients. The near ideal reverse recovery characteristics and low forward-voltage drop are particularly important diode characteristics for high-input voltage and low-output voltage applications common to the LM5575-Q1. The reverse recovery characteristic determines how long the current surge lasts each cycle when the buck switch is turned on. The reverse recovery characteristics of Schottky diodes minimize the peak instantaneous power in the buck switch occurring during turnon each cycle. The resulting switching losses of the buck switch are significantly reduced when using a Schottky diode. Select the reverse breakdown rating for the maximum  $V_{\text{IN}}$ , plus some safety margin.

The forward voltage drop has a significant impact on the conversion efficiency, especially for applications with a low output voltage. *Rated* current for diodes vary widely from various manufacturers. The worst case is to assume a short-circuit load condition. In this case the diode carries the output current almost continuously. For the LM5575-Q1 this current can be as high as 2.1 A. Assuming a worst-case, 1-V drop across the diode, the maximum diode power dissipation can be as high as 2.1 W. For the reference design a 100-V Schottky in a SMC package was selected.

### 8.2.2.8 C1, C2

The regulator supply voltage has a large source impedance at the switching frequency. Good-quality input capacitors are necessary to limit the ripple voltage at the VIN pin while supplying most of the switch current during the on-time. When the buck switch turns on, the current into the VIN pin steps to the lower peak of the inductor current waveform, ramps up to the peak value, then drops to zero at turnoff. The average current into VIN during the on-time is the load current. Select the input capacitance for RMS current rating and minimum ripple voltage. A good approximation for the required ripple current rating necessary is  $I_{\text{RMS}} > I_{\text{OUT}} / 2$ .

Select quality ceramic capacitors with a low ESR for the input filter. To allow for capacitor tolerances and voltage effects, two 1- $\mu\text{F}$ , 100-V ceramic capacitors are used. If step input voltage transients are expected near the maximum rating of the LM5575-Q1, a careful evaluation of ringing and possible spikes at the device VIN pin must be completed. An additional damping network or input voltage clamp may be required in these cases.

### 8.2.2.9 C8

The capacitor at the VCC pin provides noise filtering and stability for the  $V_{\text{CC}}$  regulator. The recommended value of C8 is no smaller than 0.1  $\mu\text{F}$  and should be a good-quality, low-ESR, ceramic capacitor. A value of 0.47  $\mu\text{F}$  was selected for this design.

### 8.2.2.10 C7

The bootstrap capacitor between the BST and the SW pins supplies the gate current to charge the buck switch gate at turnon. The recommended value of C7 is 0.022  $\mu\text{F}$  and should be a good-quality, low-ESR, ceramic capacitor.

## Typical Application (continued)

### 8.2.2.11 C4

The capacitor at the SS pin determines the soft-start time; that is, the time for the reference voltage and the output voltage, to reach the final regulated value. Equation 12 determines the time.

$$t_{ss} = \frac{C4 \times 1.225V}{10 \mu A} \quad (12)$$

For this application, a C4 value of 0.01  $\mu$ F was chosen which corresponds to a soft-start time of 1 ms.

### 8.2.2.12 R5, R6

R5 and R6 set the output voltage level. The ratio of these resistors is calculated from Equation 13:

$$R5/R6 = (V_{OUT} / 1.225V) - 1 \quad (13)$$

For a 5-V output, the R5/R6 ratio calculates to 3.082. Choose the resistors from standard value resistors. A good starting point is selection in the range of 1 k $\Omega$  to 10 k $\Omega$ . Values of 5.11 k $\Omega$  for R5, and 1.65 k $\Omega$  for R6, were selected.

### 8.2.2.13 R1, R2, C12

A voltage divider can be connected to the SD pin to set a minimum operating voltage  $V_{IN(min)}$  for the regulator. If this feature is required, the easiest approach to select the divider resistor values is to select a value for R1 (between 10 k $\Omega$  and 100 k $\Omega$  recommended) then calculate R2 from Equation 14:

$$R2 = 1.225 \times \left( \frac{R1}{V_{IN(min)} + (5 \times 10^{-6} \times R1) - 1.225} \right) \quad (14)$$

Capacitor C12 provides filtering for the divider. The voltage at the SD pin should never exceed 8 V. When using an external set-point divider, it may be necessary to clamp the SD pin at high input-voltage conditions. The reference design uses the full range of the LM5575-Q1 (6 V to 75 V); therefore, these components can be omitted. With the SD pin open circuit the LM5575-Q1 responds once the  $V_{CC}$  UVLO threshold is satisfied.

### 8.2.2.14 R7, C11

A snubber network across the power diode reduces ringing and spikes at the switching node. Excessive ringing and spikes can cause erratic operation and couple spikes and noise to the output. Voltage spikes beyond the rating of the LM5575-Q1 or the re-circulating diode can damage these devices. TI recommends to select the values for the snubber through empirical methods. First, make sure the lead lengths for the snubber connections are very short. For the current levels typical for the LM5575-Q1, a resistor value between 5 and 20  $\Omega$  is adequate. Increasing the value of the snubber capacitor results in more damping but higher losses. Select a minimum value of C11 that provides adequate damping of the SW pin waveform at high load.

### 8.2.2.15 R4, C5, C6

These components configure the error amplifier gain characteristics to accomplish a stable overall loop gain. One advantage of current mode control is the ability to close the loop with only two feedback components, R4 and C5. The overall loop gain is the product of the modulator gain and the error amplifier gain. The DC modulator gain of the LM5575-Q1 is calculated by Equation 15:

$$\text{DC Gain}_{(MOD)} = G_{m(MOD)} \times R_{LOAD} = 1 \times R_{LOAD} \quad (15)$$

The dominant low frequency pole of the modulator is determined by the load resistance ( $R_{LOAD}$ ) and output capacitance ( $C_{OUT}$ ). The corner frequency of this pole is calculated by Equation 16:

$$f_{p(MOD)} = 1 / (2\pi R_{LOAD} C_{OUT}) \quad (16)$$

For  $R_{LOAD} = 5 \Omega$  and  $C_{OUT} = 130 \mu$ F then  $f_{p(MOD)} = 245$  Hz

DC Gain<sub>(MOD)</sub> = 1  $\times$  5 = 14 dB

For the design example of [Functional Block Diagram](#), the measured modulator gain vs. frequency characteristic is shown in [Figure 18](#).

Typical Application (continued)

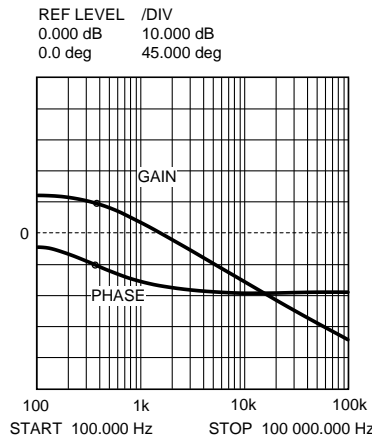

$$R_{LOAD} = 5 \Omega$$

$$C_{OUT} = 130 \mu F$$

Figure 18. Gain and Phase of Modulator

Components R4 and C5 configure the error amplifier as a type II configuration which has a pole at DC and a zero at  $f_z = 1 / (2\pi R4 C5)$ . The error amplifier zero cancels the modulator pole and leaves a single pole response at the crossover frequency of the loop gain. A single pole response at the crossover frequency yields a very stable loop with 90 degrees of phase margin.

For the design example, a target loop bandwidth (crossover frequency) of 15 kHz was selected. Select the compensation network zero ( $f_z$ ) at least an order of magnitude less than the target crossover frequency. This constrains the product of R4 and C5 for a desired compensation network zero  $1 / (2\pi R4 C5)$  to be less than 2 kHz. If the user increases R4 while they proportionally decrease C5, the error amp gain increases. Conversely, if the user decreases R4 while proportionally they increase C5, the error amp gain decreases. For the design example, C5 was selected for 0.01  $\mu F$  and R4 was selected for 49.9 k $\Omega$ . These values configure the compensation network zero at 320 Hz. The error amp gain at frequencies greater than  $f_z$  is:  $R4 / R5$ , which is approximately 10 (20 dB).

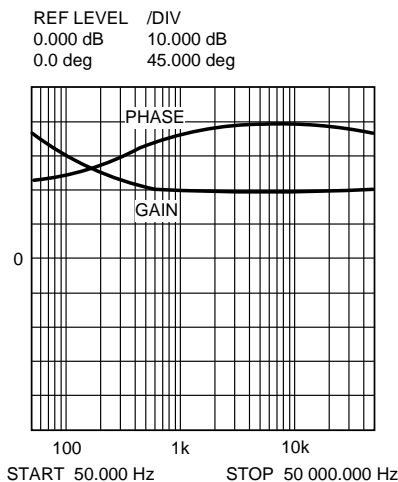

Figure 19. Error Amplifier Gain and Phase

The overall loop can be predicted as the sum (in dB) of the modulator gain and the error amp gain.

Typical Application (continued)

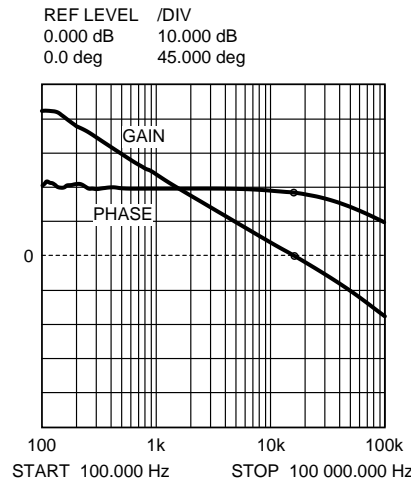
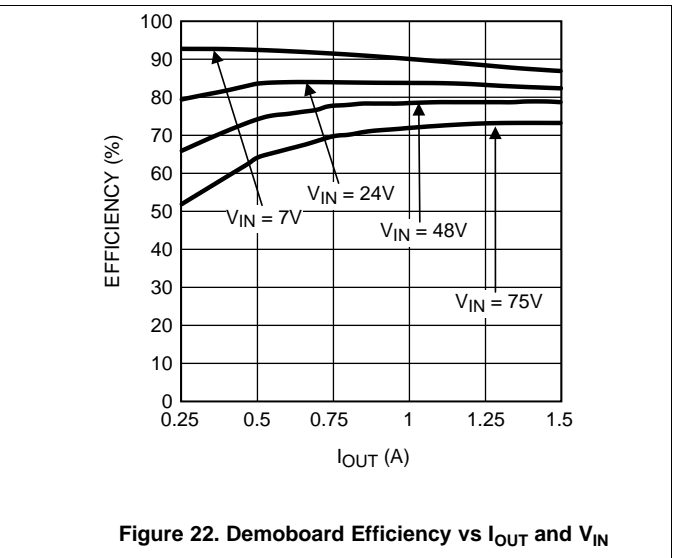
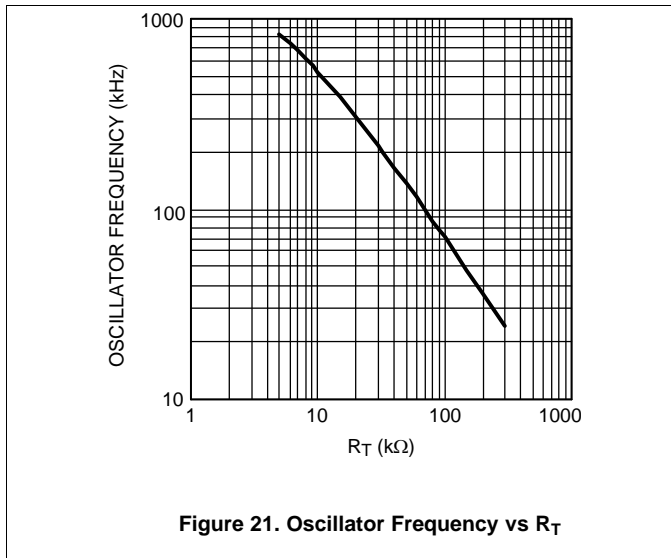

Figure 20. Overall Loop Gain and Phase

If a network analyzer is available, the modulator gain can be measured, and the error amplifier gain can be configured for the desired loop transfer function. If a network analyzer is not available, the error amplifier compensation components can be designed with the guidelines given. Step-load transient tests can be performed to verify acceptable performance. The step-load goal is minimum overshoot with a damped response. C6 can be added to the compensation network to decrease noise susceptibility of the error amplifier. The value of C6 must be sufficiently small because the addition of this capacitor adds a pole in the error amplifier transfer function. This pole must be well beyond the loop crossover frequency. A good approximation of the location of the pole added by C6 is:  $f_{p2} = f_z \times C5 / C6$ .

8.2.3 Application Curves



## 9 Power Supply Recommendations

The LM5575-Q1 is designed to operate from an input voltage supply range between 6 V and 75 V. This input supply must be able to withstand the maximum input current and maintain a voltage higher than 6 V. The resistance of the input supply rail must be low enough that an input current transient does not cause a high enough drop at the LM5575-Q1 supply voltage. That drop in supply voltage can cause a false UVLO fault trigger and system reset. If the input supply is placed more than a few inches from the LM5575-Q1, additional bulk capacitance may be required in addition to the ceramic bypass capacitors. The amount of bulk capacitance is not critical, but a 47- $\mu$ F or 100- $\mu$ F electrolytic capacitor is a typical choice.

## 10 Layout

### 10.1 Layout Guidelines

The circuit in [Functional Block Diagram](#) serves as both a block diagram of the LM5575-Q1 and a typical application board schematic for the LM5575-Q1. In a buck regulator, there are two loops where currents are switched very fast. The first loop starts from the input capacitors, to the regulator VIN pin, to the regulator SW pin, and then to the inductor then out to the load. The second loop starts from the output capacitor ground, to the regulator PGND pins, to the regulator IS pins, to the diode anode, to the inductor and then out to the load. The user can minimize the loop area of these two loops to reduce the stray inductance and to minimize noise and possible erratic operation. A ground plane in the printed-circuit board (PCB) is recommended as a means to connect the input filter capacitors to the output filter capacitors and the PGND pins of the regulator. Connect all of the low-power ground connections ( $C_{SS}$ ,  $R_T$ ,  $C_{RAMP}$ ) directly to the regulator AGND pin. Connect the AGND and PGND pins together through the top-side copper area that covers the entire underside of the device. Place several vias in this underside copper area to the ground plane.

The two highest power-dissipating components are the re-circulating diode and the LM5575-Q1 regulator IC. The easiest method to determine the power dissipated within the LM5575-Q1 is to measure the total conversion losses ( $P_{in} - P_{out}$ ) then subtract the power losses in the Schottky diode, output inductor, and snubber resistor.

[Equation 17](#) calculates an approximation for the Schottky diode loss.

$$P = (1 - D) \times I_{OUT} \times V_{fwd} \quad (17)$$

[Equation 18](#) calculates an approximation for the output inductor power.

$$P = I_{OUT}^2 \times R \times 1.1$$

where

- R is the DC resistance of the inductor and the 1.1 factor is an approximation for the AC losses (18)

If a snubber is used, [Equation 19](#) calculates an approximation for the damping resistor power dissipation.

$$P = V_{IN}^2 \times F_{sw} \times C_{snub}$$

where

- $F_{sw}$  is the switching frequency and  $C_{snub}$  is the snubber capacitor (19)

The regulator has an exposed thermal pad to help power dissipation. Add several vias under the device to the ground plane to greatly reduce the regulator junction temperature. Select a diode with an exposed pad to help the power dissipation of the diode.

The most significant variables that affect the power dissipated by the LM5575-Q1 are the output current, input voltage, and operating frequency. The power dissipated while the device operates near the maximum output current and maximum input voltage can be appreciable. The operating frequency of the LM5575-Q1 evaluation board has been designed for 300 kHz. When the device operates at 1.5-A output current with a 70-V input, the power dissipation of the LM5575-Q1 regulator is approximately 1.25 W.

10.2 Layout Examples

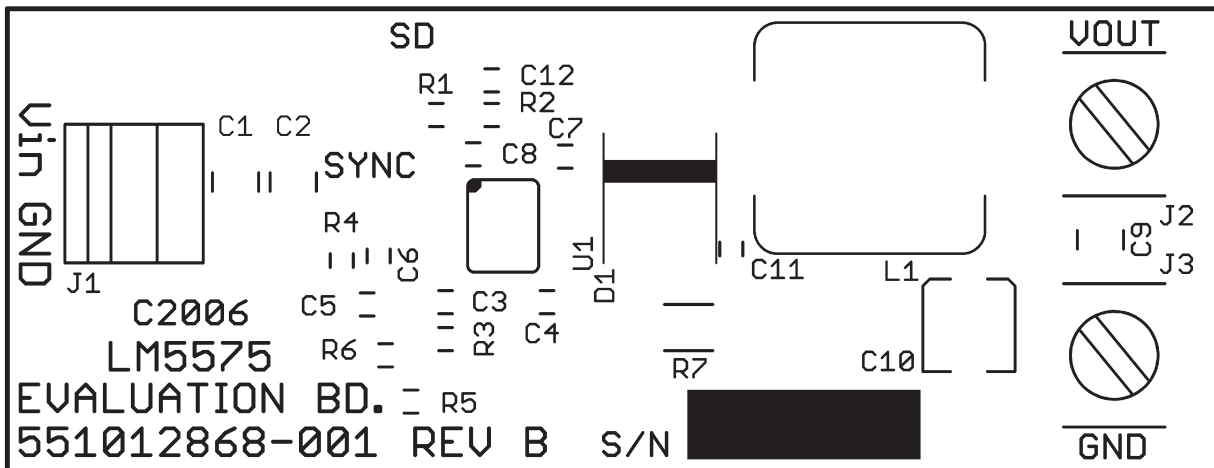

Figure 23. Silkscreen

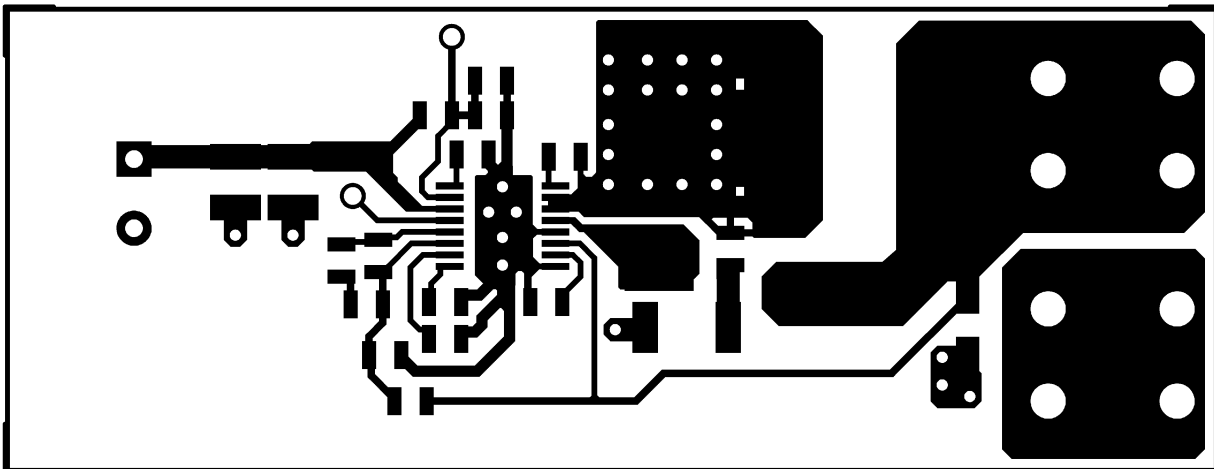

Figure 24. Component Side

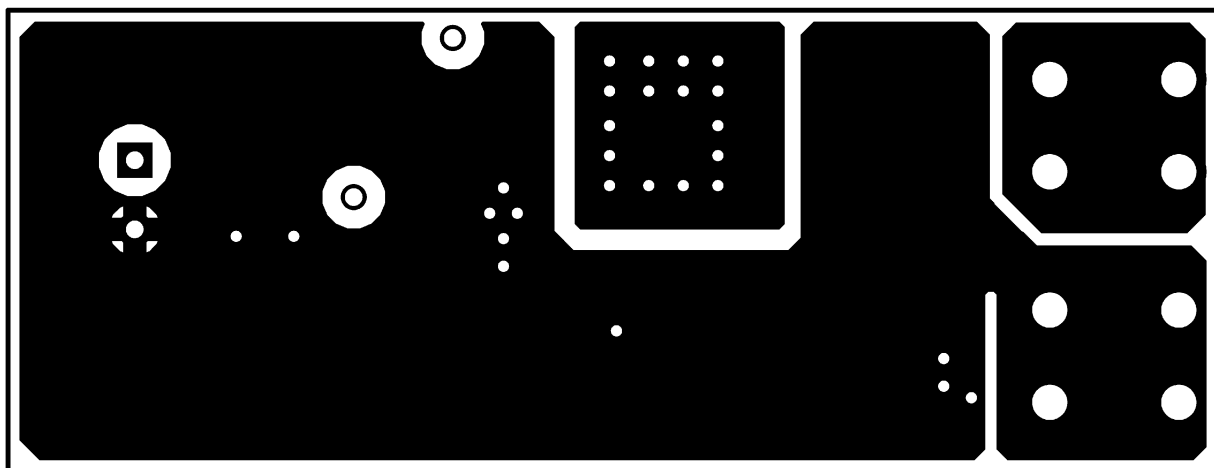

Figure 25. Solder Side



## 10.3 Thermal Considerations

The junction-to-ambient thermal resistance of the LM5575-Q1 varies with the application. The most significant variables are the area of copper in the PCB, the number of vias under the IC exposed pad, and the amount of forced air cooling provided. As shown in the evaluation board artwork, the area under the LM5575-Q1 (component side) is covered with copper and there are 5 connection vias to the solder-side ground plane. Additional vias under the IC have diminishing value as more vias are added. The integrity of the solder connection from the IC exposed pad to the PCB is critical. Excessive voids will greatly diminish the thermal dissipation capacity. The junction-to-ambient thermal resistance of the LM5575-Q1 mounted in the evaluation board varies from 50°C/W with no airflow to 28°C/W with 900 LFM (linear feet per minute). With a 25°C ambient temperature and no airflow, the predicted junction temperature for the LM5575-Q1 is  $25 + (50 \times 1.25) = 88^\circ\text{C}$ . If the evaluation board operates at 1.5-A output current, 70-V input voltage, and a high ambient temperature for a prolonged period of time, the thermal shutdown protection within the IC may activate. The IC turns off to allow the junction to cool, followed by restart with the soft-start capacitor reset to zero.

## 11 器件和文档支持

### 11.1 器件支持

#### 11.1.1 使用 WEBENCH® 工具创建定制设计

请单击[此处](#)，使用 LM5575-Q1 器件并借助 WEBENCH® 电源设计器创建定制设计。

1. 首先输入输入电压 ( $V_{\text{IN}}$ )、输出电压 ( $V_{\text{OUT}}$ ) 和输出电流 ( $I_{\text{OUT}}$ ) 要求。
2. 使用优化器拨盘优化该设计的关键参数，如效率、尺寸和成本。
3. 将生成的设计与德州仪器 (TI) 的其他可行的解决方案进行比较。

WEBENCH 电源设计器可提供定制原理图以及罗列实时价格和组件供货情况的物料清单。

在多数情况下，可执行以下操作：

- 运行电气仿真，观察重要波形以及电路性能
- 运行热性能仿真，了解电路板热性能
- 将定制原理图和布局方案以常用 CAD 格式导出
- 打印设计方案的 PDF 报告并与同事共享

有关 WEBENCH 工具的详细信息，请访问 [www.ti.com.cn/WEBENCH](http://www.ti.com.cn/WEBENCH)。

#### 11.2 接收文档更新通知

要接收文档更新通知，请导航至 [TI.com.cn](http://TI.com.cn) 上的器件产品文件夹。单击右上角的 *通知我* 进行注册，即可每周接收产品信息更改摘要。有关更改的详细信息，请查看任何已修订文档中包含的修订历史记录。

#### 11.3 社区资源

The following links connect to TI community resources. Linked contents are provided "AS IS" by the respective contributors. They do not constitute TI specifications and do not necessarily reflect TI's views; see TI's [Terms of Use](#).

**TI E2E™ Online Community** *TI's Engineer-to-Engineer (E2E) Community*. Created to foster collaboration among engineers. At [e2e.ti.com](http://e2e.ti.com), you can ask questions, share knowledge, explore ideas and help solve problems with fellow engineers.

**Design Support** *TI's Design Support* Quickly find helpful E2E forums along with design support tools and contact information for technical support.

#### 11.4 商标

E2E is a trademark of Texas Instruments.

WEBENCH is a registered trademark of Texas Instruments.

All other trademarks are the property of their respective owners.

## 11.5 静电放电警告



这些装置包含有限的内置 ESD 保护。存储或装卸时，应将导线一起截短或将装置放置于导电泡棉中，以防止 MOS 门极遭受静电损伤。

## 11.6 Glossary

[SLYZ022](#) — *TI Glossary*.

This glossary lists and explains terms, acronyms, and definitions.

## 12 机械、封装和可订购信息

以下页面包含机械、封装和可订购信息。这些信息是指定器件的最新可用数据。数据如有变更，恕不另行通知，且不会对此文档进行修订。如需获取此数据表的浏览器版本，请查阅左侧的导航栏。

**PACKAGING INFORMATION**

Orderable Device	Status (1)	Package Type	Package Drawing	Pins	Package Qty	Eco Plan (2)	Lead finish/ Ball material (6)	MSL Peak Temp (3)	Op Temp (°C)	Device Marking (4/5)	Samples
LM5575Q0MH/NOPB	ACTIVE	HTSSOP	PWP	16	92	RoHS & Green	SN	Level-1-260C-UNLIM	-40 to 150	LM5575 Q0MH	<a href="#">Samples</a>
LM5575Q0MHX/NOPB	ACTIVE	HTSSOP	PWP	16	2500	RoHS & Green	SN	Level-1-260C-UNLIM	-40 to 150	LM5575 Q0MH	<a href="#">Samples</a>
LM5575QMH/NOPB	ACTIVE	HTSSOP	PWP	16	92	RoHS & Green	SN	Level-1-260C-UNLIM	-40 to 125	LM5575 QMH	<a href="#">Samples</a>
LM5575QMHX/NOPB	ACTIVE	HTSSOP	PWP	16	2500	RoHS & Green	SN	Level-1-260C-UNLIM	-40 to 125	LM5575 QMH	<a href="#">Samples</a>

(1) The marketing status values are defined as follows:

**ACTIVE:** Product device recommended for new designs.

**LIFEBUY:** TI has announced that the device will be discontinued, and a lifetime-buy period is in effect.

**NRND:** Not recommended for new designs. Device is in production to support existing customers, but TI does not recommend using this part in a new design.

**PREVIEW:** Device has been announced but is not in production. Samples may or may not be available.

**OBSOLETE:** TI has discontinued the production of the device.

(2) **RoHS:** TI defines "RoHS" to mean semiconductor products that are compliant with the current EU RoHS requirements for all 10 RoHS substances, including the requirement that RoHS substance do not exceed 0.1% by weight in homogeneous materials. Where designed to be soldered at high temperatures, "RoHS" products are suitable for use in specified lead-free processes. TI may reference these types of products as "Pb-Free".

**RoHS Exempt:** TI defines "RoHS Exempt" to mean products that contain lead but are compliant with EU RoHS pursuant to a specific EU RoHS exemption.

**Green:** TI defines "Green" to mean the content of Chlorine (Cl) and Bromine (Br) based flame retardants meet JS709B low halogen requirements of <=1000ppm threshold. Antimony trioxide based flame retardants must also meet the <=1000ppm threshold requirement.

(3) MSL, Peak Temp. - The Moisture Sensitivity Level rating according to the JEDEC industry standard classifications, and peak solder temperature.

(4) There may be additional marking, which relates to the logo, the lot trace code information, or the environmental category on the device.

(5) Multiple Device Markings will be inside parentheses. Only one Device Marking contained in parentheses and separated by a "~" will appear on a device. If a line is indented then it is a continuation of the previous line and the two combined represent the entire Device Marking for that device.

(6) Lead finish/Ball material - Orderable Devices may have multiple material finish options. Finish options are separated by a vertical ruled line. Lead finish/Ball material values may wrap to two lines if the finish value exceeds the maximum column width.

**Important Information and Disclaimer:** The information provided on this page represents TI's knowledge and belief as of the date that it is provided. TI bases its knowledge and belief on information provided by third parties, and makes no representation or warranty as to the accuracy of such information. Efforts are underway to better integrate information from third parties. TI has taken and

continues to take reasonable steps to provide representative and accurate information but may not have conducted destructive testing or chemical analysis on incoming materials and chemicals. TI and TI suppliers consider certain information to be proprietary, and thus CAS numbers and other limited information may not be available for release.

In no event shall TI's liability arising out of such information exceed the total purchase price of the TI part(s) at issue in this document sold by TI to Customer on an annual basis.

**OTHER QUALIFIED VERSIONS OF LM5575-Q1 :**

- Catalog : [LM5575](#)

NOTE: Qualified Version Definitions:

- Catalog - TI's standard catalog product

**TAPE AND REEL INFORMATION**

**QUADRANT ASSIGNMENTS FOR PIN 1 ORIENTATION IN TAPE**

\*All dimensions are nominal

Device	Package Type	Package Drawing	Pins	SPQ	Reel Diameter (mm)	Reel Width W1 (mm)	A0 (mm)	B0 (mm)	K0 (mm)	P1 (mm)	W (mm)	Pin1 Quadrant
LM5575Q0MHX/NOPB	HTSSOP	PWP	16	2500	330.0	12.4	6.9	5.6	1.6	8.0	12.0	Q1
LM5575QMHX/NOPB	HTSSOP	PWP	16	2500	330.0	12.4	6.9	5.6	1.6	8.0	12.0	Q1

## TAPE AND REEL BOX DIMENSIONS



\*All dimensions are nominal

Device	Package Type	Package Drawing	Pins	SPQ	Length (mm)	Width (mm)	Height (mm)
LM5575Q0MHX/NOPB	HTSSOP	PWP	16	2500	367.0	367.0	35.0
LM5575QMHX/NOPB	HTSSOP	PWP	16	2500	367.0	367.0	35.0

**TUBE**

\*All dimensions are nominal

Device	Package Name	Package Type	Pins	SPQ	L (mm)	W (mm)	T (μm)	B (mm)
LM5575Q0MH/NOPB	PWP	HTSSOP	16	92	495	8	2514.6	4.06
LM5575QMH/NOPB	PWP	HTSSOP	16	92	495	8	2514.6	4.06
LM5575QMH/NOPB	PWP	HTSSOP	16	92	495	8	2514.6	4.06



4214868/A 02/2017

NOTES:

PowerPAD is a trademark of Texas Instruments.

1. All linear dimensions are in millimeters. Any dimensions in parenthesis are for reference only. Dimensioning and tolerancing per ASME Y14.5M.
2. This drawing is subject to change without notice.
3. This dimension does not include mold flash, protrusions, or gate burrs. Mold flash, protrusions, or gate burrs shall not exceed 0.15 mm per side.
4. Reference JEDEC registration MO-153.
5. Features may not be present.



# EXAMPLE BOARD LAYOUT

PWP0016A

PowerPAD™ HTSSOP - 1.2 mm max height

PLASTIC SMALL OUTLINE

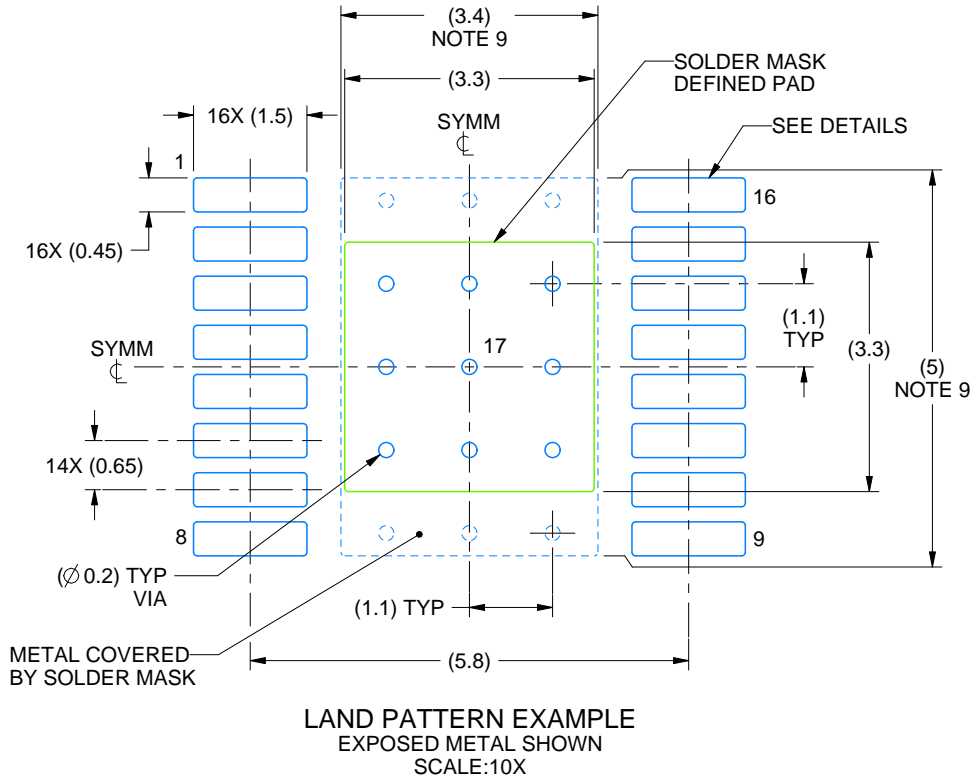

4214868/A 02/2017

NOTES: (continued)

6. Publication IPC-7351 may have alternate designs.
7. Solder mask tolerances between and around signal pads can vary based on board fabrication site.
8. This package is designed to be soldered to a thermal pad on the board. For more information, see Texas Instruments literature numbers SLMA002 ([www.ti.com/lit/slma002](http://www.ti.com/lit/slma002)) and SLMA004 ([www.ti.com/lit/slma004](http://www.ti.com/lit/slma004)).
9. Size of metal pad may vary due to creepage requirement.

# EXAMPLE STENCIL DESIGN

PWP0016A

PowerPAD™ HTSSOP - 1.2 mm max height

PLASTIC SMALL OUTLINE

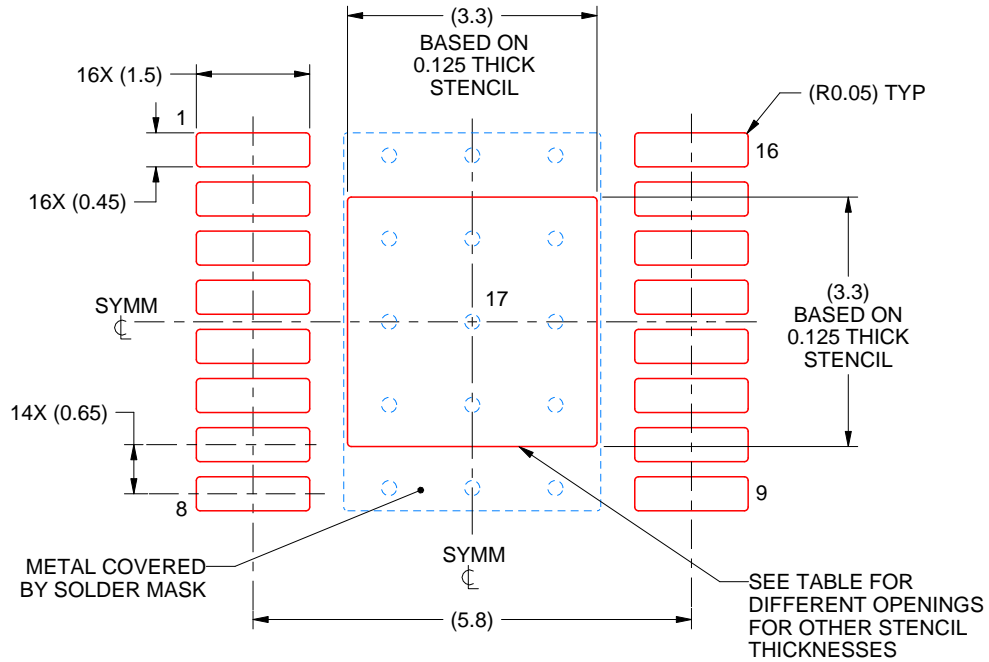

SOLDER PASTE EXAMPLE  
 EXPOSED PAD  
 100% PRINTED SOLDER COVERAGE BY AREA  
 SCALE:10X

STENCIL THICKNESS	SOLDER STENCIL OPENING
0.1	3.69 X 3.69
0.125	3.3 X 3.3 (SHOWN)
0.15	3.01 X 3.01
0.175	2.79 X 2.79

4214868/A 02/2017

NOTES: (continued)

10. Laser cutting apertures with trapezoidal walls and rounded corners may offer better paste release. IPC-7525 may have alternate design recommendations.
11. Board assembly site may have different recommendations for stencil design.

## 重要通知和免责声明

TI“按原样”提供技术和可靠性数据（包括数据表）、设计资源（包括参考设计）、应用或其他设计建议、网络工具、安全信息和其他资源，不保证没有瑕疵且不做任何明示或暗示的担保，包括但不限于对适销性、某特定用途方面的适用性或不侵犯任何第三方知识产权的暗示担保。

这些资源可供使用 TI 产品进行设计的熟练开发人员使用。您将自行承担以下全部责任：(1) 针对您的应用选择合适的 TI 产品，(2) 设计、验证并测试您的应用，(3) 确保您的应用满足相应标准以及任何其他功能安全、信息安全、监管或其他要求。

这些资源如有变更，恕不另行通知。TI 授权您仅可将这些资源用于研发本资源所述的 TI 产品的相关应用。严禁以其他方式对这些资源进行复制或展示。您无权使用任何其他 TI 知识产权或任何第三方知识产权。您应全额赔偿因在这些资源的使用中对 TI 及其代表造成的任何索赔、损害、成本、损失和债务，TI 对此概不负责。

TI 提供的产品受 [TI 的销售条款](#) 或 [ti.com](#) 上其他适用条款/TI 产品随附的其他适用条款的约束。TI 提供这些资源并不会扩展或以其他方式更改 TI 针对 TI 产品发布的适用的担保或担保免责声明。

TI 反对并拒绝您可能提出的任何其他或不同的条款。

邮寄地址：Texas Instruments, Post Office Box 655303, Dallas, Texas 75265  
版权所有 © 2025，德州仪器 (TI) 公司