

## LM614x 17MHz Rail-to-Rail Input-Output Operational Amplifiers

### 1 Features

At  $V_S = 5V$ . Typ Unless Noted.

- Rail-to-rail Input CMVR  $-0.25V$  to  $5.25V$
- Rail-to-Rail Output
- Wide Gain-Bandwidth: 17MHz at 50kHz (typ)
- Slew Rate:  $30V/\mu s$
- Low Supply Current  $650\mu A$ /Amplifier
- Wide Supply Range  $2.7V$  to  $24V$
- CMRR 107dB
- Gain 108dB with  $R_L = 10k$
- PSRR 87dB

### 2 Applications

- Battery Operated Instrumentation
- Depth Sounders/Fish Finders
- Barcode Scanners
- Wireless Communications
- Rail-to-Rail in-out Instrumentation Amps

### 3 Description

Using patent pending new circuit topologies, the LM6142/LM6144 provides new levels of performance in applications where low voltage supplies or power limitations previously made compromise necessary. Operating on supplies of  $2.7V$  to over  $24V$ , the LM6142/LM6144 is an excellent choice for battery operated systems, portable instrumentation and others.

The greater than rail-to-rail input voltage range eliminates concern over exceeding the common-mode voltage range. The rail-to-rail output swing provides the maximum possible dynamic range at the output. This is particularly important when operating on low supply voltages.

High gain-bandwidth with  $650\mu A$ /Amplifier supply current opens new battery powered applications where previous higher power consumption reduced battery life to unacceptable levels. The ability to drive large capacitive loads without oscillating functionally removes this common problem.

#### Device Information

| PART NUMBER | CHANNEL COUNT | PACKAGE <sup>(1)</sup> | BODY SIZE         |
|-------------|---------------|------------------------|-------------------|
| LM6142      | Dual          | D (SOIC, 8)            | 4.90mm × 3.91mm   |
|             |               | P (PDIP, 8)            | 9.81mm × 6.35mm   |
| LM6144      | Quad          | D (SOIC, 14)           | 8.65mm × 3.91mm   |
|             |               | NFF (PDIP, 14)         | 19.177mm × 6.35mm |



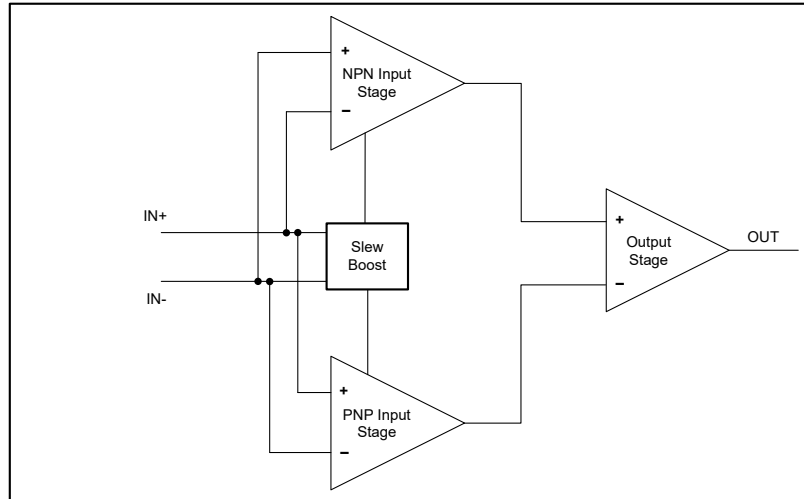

**Functional Block Diagram**

## Table of Contents

|  |    |  |    |
|--|----|--|----|
| <b>1 Features</b> .....                            | 1  | 5.9 Typical Characteristics.....                             | 11 |
| <b>2 Applications</b> .....                        | 1  | 5.10 Old Versus New Die Comparison.....                      | 16 |
| <b>3 Description</b> .....                         | 1  | <b>6 Application and Implementation</b> .....                | 17 |
| <b>4 Connection Diagrams</b> .....                 | 4  | 6.1 Application Information.....                             | 17 |
| <b>5 Specifications</b> .....                      | 5  | 6.2 Typical Applications.....                                | 17 |
| 5.1 Absolute Maximum Ratings.....                  | 5  | <b>7 Device and Documentation Support</b> .....              | 19 |
| 5.2 ESD Ratings.....                               | 5  | 7.1 Receiving Notification of Documentation Updates....      | 19 |
| 5.3 Recommended Operating Conditions.....          | 5  | 7.2 Support Resources.....                                   | 19 |
| 5.4 Thermal Information LM6142.....                | 6  | 7.3 Electrostatic Discharge Caution.....                     | 19 |
| 5.5 Thermal Information LM6144.....                | 6  | 7.4 Glossary.....  | 19 |
| 5.6 Electrical Characteristics: $V_S = 5V$ .....   | 7  | <b>8 Revision History</b> .....                              | 20 |
| 5.7 Electrical Characteristics: $V_S = 2.7V$ ..... | 9  | <b>9 Mechanical, Packaging, and Orderable Information</b> .. | 22 |
| 5.8 Electrical Characteristics: $V_S = 24V$ .....  | 10 |  |    |

## 4 Connection Diagrams

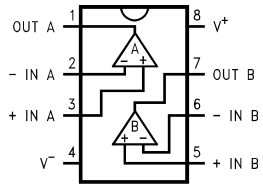

**Figure 4-1. 8-Pin CDIP  
Top View**

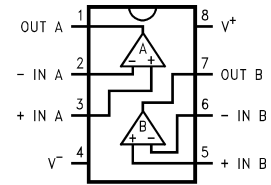

**Figure 4-2. 8-Pin PDIP/SOIC  
Top View**

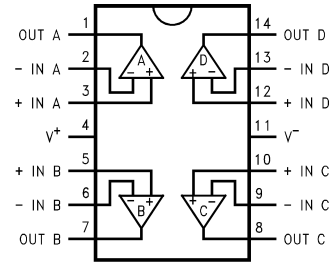

**Figure 4-3. 14-Pin PDIP/SOIC  
Top View**

## 5 Specifications

### 5.1 Absolute Maximum Ratings

over operating ambient temperature range (unless otherwise noted)<sup>(1)</sup>

|                                      |                                     | MIN          | MAX          | UNIT |
|--------------------------------------|-------------------------------------|--------------|--------------|------|
| Supply voltage, $V_S = (V+) - (V-)$  |                                     | 0            | 33           | V    |
| Signal input pins                    | Common-mode voltage <sup>(3)</sup>  | $(V-) - 0.5$ | $(V+) + 0.5$ | V    |
|                                      | Differential voltage <sup>(4)</sup> |              | ±15          | V    |
|                                      | Current <sup>(3)</sup>              |              | ±10          | mA   |
| Output short-circuit <sup>(2)</sup>  |                                     | Continuous   |              |      |
| Operating ambient temperature, $T_A$ |                                     | -55          | 150          | °C   |
| Junction temperature, $T_J$          |                                     |              | 150          | °C   |
| Storage temperature, $T_{stg}$       |                                     | -65          | 150          | °C   |

- Operating the device beyond the ratings listed under *Absolute Maximum Ratings* will cause permanent damage to the device. These are stress ratings only, based on process and design limitations, and this device has not been designed to function outside the conditions indicated under *Recommended Operating Conditions*. Exposure to any condition outside *Recommended Operating Conditions* for extended periods, including absolute-maximum-rated conditions, may affect device reliability and performance.
- Short-circuit to ground, one amplifier per package. Extended short-circuit current, especially with higher supply voltage, can cause excessive heating and eventual destruction.
- Input pins are diode-clamped to the power-supply rails. Input signals that may swing more than 0.5 V beyond the supply rails must be current limited to 10 mA or less.
- Input pins are connected by back-to-back diodes for input protection. If the differential input voltage may exceed 0.5 V, limit the input current to 10mA or less.

### 5.2 ESD Ratings

|             |                         |   | VALUE | UNIT |
|-------------|-------------------------|---|-------|------|
| $V_{(ESD)}$ | Electrostatic discharge | Human-body model (HBM), per ANSI/ESDA/JEDEC JS-001 <sup>(1)</sup>     | ±4000 | V    |
|             |                         | Charged-device model (CDM), per ANSI/ESDA/JEDEC JS-002 <sup>(2)</sup> | ±1500 |      |

- JEDEC document JEP155 states that 500-V HBM allows safe manufacturing with a standard ESD control process.
- JEDEC document JEP157 states that 250-V CDM allows safe manufacturing with a standard ESD control process.

### 5.3 Recommended Operating Conditions

over operating ambient temperature range (unless otherwise noted)

|       |                               | MIN | MAX | UNIT |
|-------|-------------------------------|-----|-----|------|
| $V_S$ | Supply voltage, $(V+) - (V-)$ | 2.7 | 32  | V    |
| $T_A$ | Specified temperature         | -40 | 85  | °C   |

## 5.4 Thermal Information LM6142

| THERMAL METRIC <sup>(1)</sup> |  | LM6142                     |                            | UNIT |
|-------------------------------|--|----------------------------|----------------------------|------|
|                               |  | D<br>(SOIC) <sup>(1)</sup> | P<br>(PDIP) <sup>(1)</sup> |      |
|                               |  | 8 PINS                     | 8 PINS                     |      |
| $R_{\theta JA}$               | Junction-to-ambient thermal resistance       | 127.10                     | 84.45                      | °C/W |
| $R_{\theta JC(top)}$          | Junction-to-case (top) thermal resistance    | 63.27                      | 58.07                      | °C/W |
| $R_{\theta JB}$               | Junction-to-board thermal resistance         | 71.20                      | 50.90                      | °C/W |
| $\Psi_{JT}$                   | Junction-to-top characterization parameter   | 13.91                      | 30.43                      | °C/W |
| $\Psi_{JB}$                   | Junction-to-board characterization parameter | 70.54                      | 50.44                      | °C/W |

(1) For more information about traditional and new thermal metrics, see the *Semiconductor and IC Package Thermal Metrics* application report, [SPRA953](#).

## 5.5 Thermal Information LM6144

| THERMAL METRIC <sup>(1)</sup> |  | LM6144                     |                              | Unit |
|-------------------------------|--|----------------------------|------------------------------|------|
|                               |  | D<br>(SOIC) <sup>(1)</sup> | NFF<br>(PDIP) <sup>(1)</sup> |      |
|                               |  | 14 PINS                    | 14 PINS                      |      |
| $R_{\theta JA}$               | Junction-to-ambient thermal resistance       | 82.48                      | 81                           | °C/W |
| $R_{\theta JC(top)}$          | Junction-to-case (top) thermal resistance    | 38.77                      | N/A                          | °C/W |
| $R_{\theta JB}$               | Junction-to-board thermal resistance         | 37.86                      | N/A                          | °C/W |
| $\Psi_{JT}$                   | Junction-to-top characterization parameter   | 8.66                       | N/A                          | °C/W |
| $\Psi_{JB}$                   | Junction-to-board characterization parameter | 37.51                      | N/A                          | °C/W |

(1) For more information about traditional and new thermal metrics, see the *Semiconductor and IC Package Thermal Metrics* application report, [SPRA953](#).

## 5.6 Electrical Characteristics: $V_S = 5V$

For  $V^+ = 5.0V$ ,  $V^- = 0V$ ,  $R_L > 1M\Omega$  connected to  $V_S / 2$ ,  $V_{CM} = V^+ / 2$ , and  $V_O = V^+ / 2$ , at  $T_A = 25^\circ C$ , unless otherwise noted.

| PARAMETER  |  | TEST CONDITIONS                                    |                                     | MIN                                 | TYP  | MAX  | UNIT             |     |
|--|--|--|-------------------------------------|-------------------------------------|------|------|------------------|-----|
| <b>OFFSET VOLTAGE</b>                            |  |  |                                     |                                     |      |      |                  |     |
| $V_{OS}$   | Input offset voltage                     | LM6142AI, LM6144AI                                 |                                     |                                     | 0.3  | 1    | mV               |     |
|  |  |  | $T_A = -40^\circ C$ to $85^\circ C$ |                                     |      |      |                  | 2.2 |
|  |  | LM6142BI, LM6144BI                                 |                                     |                                     | 0.3  | 2.5  |                  |     |
|  |  |  | $T_A = -40^\circ C$ to $85^\circ C$ |                                     |      |      |                  | 3.3 |
| $dV_{OS}/dT$                                     | Input offset voltage drift               | $T_A = -40^\circ C$ to $85^\circ C$                |                                     |                                     | 3    |      | $\mu V/^\circ C$ |     |
| PSRR   | Input offset voltage versus power supply | 2.5V $\leq  V_S  \leq 12V$ ,<br>LM6132AI, LM6134AI |                                     | 78                                  | 82   |      | dB               |     |
|  |  |  | $T_A = -40^\circ C$ to $85^\circ C$ |                                     | 75   |      |                  |     |
|  |  | 2.5V $\leq  V_S  \leq 12V$ ,<br>LM6132BI, LM6134BI |                                     | 78                                  | 82   |      |                  |     |
|  |  |  | $T_A = -40^\circ C$ to $85^\circ C$ |                                     | 75   |      |                  |     |
|  | Amp-to-amp isolation                     |  |                                     |                                     | 130  |      | dB               |     |
| <b>INPUT BIAS CURRENT</b>                        |  |  |                                     |                                     |      |      |                  |     |
| $I_B$  | Input bias current                       | LM6142AI, LM6144AI                                 |                                     |                                     | 170  | 250  | nA               |     |
|  |  | LM6142BI, LM6144BI                                 |                                     |                                     | 170  | 300  |                  |     |
|  |  | 0V $\leq V_{CM} \leq 5V$ ,<br>LM6142AI, LM6144AI   |                                     | 180                                 | 280  |      |                  |     |
|  |  |  | $T_A = -40^\circ C$ to $85^\circ C$ |                                     |      | 526  |                  |     |
| 0V $\leq V_{CM} \leq 5V$ ,<br>LM6142BI, LM6144BI |  | 180  |                                     |                                     |      |      |                  |     |
|  | $T_A = -40^\circ C$ to $85^\circ C$      |  |                                     | 526                                 |      |      |                  |     |
| $I_{OS}$   | Input offset current                     | LM6142AI, LM6144AI                                 |                                     |                                     | 3    | 30   | nA               |     |
|  |  |  |                                     | $T_A = -40^\circ C$ to $85^\circ C$ |      |      |                  | 80  |
|  |  | LM6142BI, LM6144BI                                 |                                     |                                     | 3    | 30   |                  |     |
|  |  |  |                                     | $T_A = -40^\circ C$ to $85^\circ C$ |      |      |                  | 80  |
| <b>INPUT VOLTAGE</b>                             |  |  |                                     |                                     |      |      |                  |     |
| $V_{CM}$   | Common-mode input voltage range          |  |                                     | -0.25                               |      | 5.25 | V                |     |
|  |  | $T_A = -40^\circ C$ to $85^\circ C$                |                                     |                                     | 0    | 5    | V                |     |
| CMRR   | Common-mode rejection ratio              | 0V $\leq V_{CM} \leq 4V$ ,<br>LM6142AI, LM6144AI   |                                     | 84                                  | 107  |      | dB               |     |
|  |  |  | $T_A = -40^\circ C$ to $85^\circ C$ |                                     | 78   |      |                  |     |
|  |  | 0V $\leq V_{CM} \leq 4V$ ,<br>LM6142BI, LM6144BI   |                                     | 84                                  | 107  |      |                  |     |
|  |  |  | $T_A = -40^\circ C$ to $85^\circ C$ |                                     | 78   |      |                  |     |
|  |  | 0V $\leq V_{CM} \leq 5V$ ,<br>LM6142AI, LM6144AI   |                                     | 66                                  | 82   |      |                  |     |
|  |  |  | $T_A = -40^\circ C$ to $85^\circ C$ |                                     | 64   | 79   |                  |     |
| 0V $\leq V_{CM} \leq 5V$ ,<br>LM6142BI, LM6144BI |  | 66   | 82                                  |                                     |      |      |                  |     |
|  | $T_A = -40^\circ C$ to $85^\circ C$      |  | 64                                  | 79                                  |      |      |                  |     |
| <b>INPUT IMPEDANCE</b>                           |  |  |                                     |                                     |      |      |                  |     |
| $R_{IN}$   | Common-mode input resistance             |  |                                     |                                     | 126  |      | M $\Omega$       |     |
| <b>OPEN-LOOP GAIN</b>                            |  |  |                                     |                                     |      |      |                  |     |
| $A_{OL}$   | Open-loop voltage gain                   | $R_L = 10k\Omega$ ,<br>LM6142AI, LM6144AI          |                                     | 100                                 | 270  |      | V/mV             |     |
|  |  |  | $T_A = -40^\circ C$ to $85^\circ C$ |                                     | 33   | 70   |                  |     |
|  |  | $R_L = 10k\Omega$ ,<br>LM6142BI, LM6144BI          |                                     | 80                                  | 270  |      |                  |     |
|  |  |  | $T_A = -40^\circ C$ to $85^\circ C$ |                                     | 25   | 70   |                  |     |
| <b>NOISE</b>                                     |  |  |                                     |                                     |      |      |                  |     |
| $e_N$  | Input voltage noise density              | $f = 1kHz$   |                                     |                                     | 16   |      | nV/ $\sqrt{Hz}$  |     |
| $i_N$  | Input current noise density              | $f = 1kHz$   |                                     |                                     | 0.22 |      | pA/ $\sqrt{Hz}$  |     |
| <b>FREQUENCY RESPONSE</b>                        |  |  |                                     |                                     |      |      |                  |     |
| GBW  | Gain-bandwidth product                   | $f = 50kHz$  |                                     |                                     | 10   | 17   | MHz              |     |
|  |  |  |                                     | $T_A = -40^\circ C$ to $85^\circ C$ |      | 6    |                  |     |

**LM6142, LM6144**

SNOS726E – JUNE 2000 – REVISED JUNE 2026

 For  $V^+ = 5.0V$ ,  $V^- = 0V$ ,  $R_L > 1M\Omega$  connected to  $V_S / 2$ ,  $V_{CM} = V^+ / 2$ , and  $V_O = V^+ / 2$ , at  $T_A = 25^\circ C$ , unless otherwise noted.

| PARAMETER                                |                                     | TEST CONDITIONS                                  |  | MIN   | TYP | MAX      | UNIT       |
|--|-------------------------------------|--|--|-------|-----|----------|------------|
| SR                                       | Slew rate                           | $V_S = 12V$ , $V_{STEP} = 8V$ , $R_S > 1k\Omega$ | LM6142AI, LM6144AI   | 15    | 25  |          | V/ $\mu s$ |
|  |                                     |  | LM6142AI, LM6144AI,<br>$T_A = -40^\circ C$ to $85^\circ C$ | 13    |     |          |            |
|  |                                     |  | LM6142AI, LM6144AI   | 13    | 25  |          |            |
|  |                                     |  | LM6142AI, LM6144AI,<br>$T_A = -40^\circ C$ to $85^\circ C$ | 11    |     |          |            |
| PM                                       | Phase margin                        |  |  | 38    |     | $^\circ$ |            |
| THD+N                                    | Total harmonic distortion + noise   | $f = 10kHz$ , $R_L = 10k\Omega$                  |  | 0.003 |     |          | %          |
| <b>OUTPUT</b>                            |                                     |  |  |       |     |          |            |
| $V_O$                                    | Voltage output swing                | $R_L = 100k\Omega$ ,<br>From positive rail       |  |       | 30  | 40       | mV         |
|  |                                     |  | $T_A = -40^\circ C$ to $85^\circ C$                        |       |     | 70       |            |
|  |                                     | $R_L = 100k\Omega$ ,<br>From negative rail       |  |       | 45  | 50       |            |
|  |                                     |  | $T_A = -40^\circ C$ to $85^\circ C$                        |       |     | 60       |            |
|  |                                     | $R_L = 10k\Omega$ ,<br>From positive rail        |  |       | 40  |          |            |
|  |                                     |  | $R_L = 10k\Omega$ ,<br>From negative rail                  |       | 50  |          |            |
| $R_L = 2k\Omega$ ,<br>From positive rail |                                     |  | 100  | 140   |     |          |            |
|  | $T_A = -40^\circ C$ to $85^\circ C$ |  |  | 200   |     |          |            |
| $R_L = 2k\Omega$ ,<br>From negative rail |                                     |  | 60   | 100   |     |          |            |
|  | $T_A = -40^\circ C$ to $85^\circ C$ |  |  | 133   |     |          |            |
| $I_{SC}$                                 | Short-circuit current               | Sourcing, LM6142A                                |  | 10    | 13  |          | mA         |
|  |                                     |  | $T_A = -40^\circ C$ to $85^\circ C$                        | 4.9   |     | 35       |            |
|  |                                     | Sourcing, LM6142B                                |  | 8     | 13  |          |            |
|  |                                     |  | $T_A = -40^\circ C$ to $85^\circ C$                        | 4     |     | 35       |            |
|  |                                     | Sinking, LM6142A                                 |  | 10    | 24  |          |            |
|  |                                     |  | $T_A = -40^\circ C$ to $85^\circ C$                        | 5.3   |     | 35       |            |
|  |                                     | Sinking, LM6142B                                 |  | 10    | 24  |          |            |
|  |                                     |  | $T_A = -40^\circ C$ to $85^\circ C$                        | 5.3   |     | 35       |            |
| Sourcing, LM6144A                        |                                     | 6  | 8  |       |     |          |            |
|  | $T_A = -40^\circ C$ to $85^\circ C$ | 3  |  | 35    |     |          |            |
| Sourcing, LM6144B                        |                                     | 6  | 8  |       |     |          |            |
|  | $T_A = -40^\circ C$ to $85^\circ C$ | 3  |  | 25    |     |          |            |
| Sinking, LM6144A                         |                                     | 8  | 22   |       |     |          |            |
|  | $T_A = -40^\circ C$ to $85^\circ C$ | 4  |  | 25    |     |          |            |
| Sinking, LM6144B                         |                                     | 8  | 22   |       |     |          |            |
|  | $T_A = -40^\circ C$ to $85^\circ C$ | 4  |  | 35    |     |          |            |
| <b>POWER SUPPLY</b>                      |                                     |  |  |       |     |          |            |
| $I_Q$                                    | Quiescent current per amplifier     | LM6142AI, LM6144AI                               |  |       | 650 | 800      | $\mu A$    |
|  |                                     |  | $T_A = -40^\circ C$ to $85^\circ C$                        |       |     | 880      |            |
|  |                                     | LM6142BI, LM6144BI                               |  |       | 650 | 800      | $\mu A$    |
|  |                                     |  | $T_A = -40^\circ C$ to $85^\circ C$                        |       |     | 880      | $\mu A$    |

## 5.7 Electrical Characteristics: $V_S = 2.7V$

For  $V^+ = 2.7V$ ,  $V^- = 0V$ ,  $R_L > 1M\Omega$  connected to  $V_S / 2$ ,  $V_{CM} = V^+ / 2$ , and  $V_O = V^+ / 2$ , at  $T_A = 25^\circ C$ , unless otherwise noted.

| PARAMETER                 |  | TEST CONDITIONS                            |                                     | MIN | TYP | MAX | UNIT      |
|---------------------------|--|--|-------------------------------------|-----|-----|-----|-----------|
| <b>OFFSET VOLTAGE</b>     |  |  |                                     |     |     |     |           |
| $V_{OS}$                  | Input offset voltage                     | LM6142AI, LM6144AI                         |                                     |     | 0.4 | 1.8 | mV        |
|                           |  |  | $T_A = -40^\circ C$ to $85^\circ C$ |     |     | 4.3 |           |
|                           |  | LM6142BI, LM6144BI                         |                                     |     | 0.4 | 2.5 |           |
|                           |  |  | $T_A = -40^\circ C$ to $85^\circ C$ |     |     | 5   |           |
| PSRR                      | Input offset voltage versus power supply | $3V \leq V^+ \leq 5V$                      |                                     |     | 79  |     | dB        |
| <b>INPUT BIAS CURRENT</b> |  |  |                                     |     |     |     |           |
| $I_B$                     | Input bias current                       | LM6142AI, LM6144AI                         |                                     |     | 150 | 250 | nA        |
|                           |  |  | $T_A = -40^\circ C$ to $85^\circ C$ |     |     | 526 |           |
|                           |  | LM6142BI, LM6144BI                         |                                     |     | 150 | 300 |           |
|                           |  |  | $T_A = -40^\circ C$ to $85^\circ C$ |     |     | 526 |           |
| $I_{OS}$                  | Input offset current                     | LM6142AI, LM6144AI                         |                                     |     | 4   | 30  | nA        |
|                           |  |  | $T_A = -40^\circ C$ to $85^\circ C$ |     |     | 80  |           |
|                           |  | LM6142BI, LM6144BI                         |                                     |     | 4   | 30  |           |
|                           |  |  | $T_A = -40^\circ C$ to $85^\circ C$ |     |     | 80  |           |
| <b>INPUT VOLTAGE</b>      |  |  |                                     |     |     |     |           |
| $V_{CM}$                  | Common-mode input voltage range          |  |                                     | 0   |     | 2.7 | V         |
| CMRR                      | Common-mode rejection ratio              | $0V \leq V_{CM} \leq 1.8V$                 |                                     |     | 90  |     | dB        |
|                           |  | $0V \leq V_{CM} \leq 2.7V$                 |                                     |     | 76  |     |           |
| <b>INPUT IMPEDANCE</b>    |  |  |                                     |     |     |     |           |
| $R_{IN}$                  | Common-mode input resistance             |  |                                     |     | 128 |     | $M\Omega$ |
| <b>OPEN-LOOP GAIN</b>     |  |  |                                     |     |     |     |           |
| $A_{OL}$                  | Open-loop voltage gain                   | $R_L = 10k\Omega$                          |                                     |     | 55  |     | V/mV      |
| <b>NOISE</b>              |  |  |                                     |     |     |     |           |
| <b>FREQUENCY RESPONSE</b> |  |  |                                     |     |     |     |           |
| GBW                       | Gain-bandwidth product                   | $f = 50kHz$                                |                                     |     | 9   |     | MHz       |
| PM                        | Phase margin                             |  |                                     |     | 36  |     | $^\circ$  |
| GM                        | Gain margin                              |  |                                     |     | 6   |     | dB        |
| <b>OUTPUT</b>             |  |  |                                     |     |     |     |           |
| $V_O$                     | Voltage output swing                     | $R_L = 100k\Omega$ ,<br>From positive rail |                                     |     | 30  | 75  | mV        |
|                           |  |  | $T_A = -40^\circ C$ to $85^\circ C$ |     |     | 450 |           |
|                           |  | $R_L = 100k\Omega$ ,<br>From negative rail |                                     |     | 19  | 80  |           |
|                           |  |  | $T_A = -40^\circ C$ to $85^\circ C$ |     |     | 112 |           |
| <b>POWER SUPPLY</b>       |  |  |                                     |     |     |     |           |
| $I_Q$                     | Quiescent current per amplifier          | LM6142AI, LM6144AI                         |                                     |     | 510 | 800 | $\mu A$   |
|                           |  |  | $T_A = -40^\circ C$ to $85^\circ C$ |     |     | 880 |           |
|                           |  | LM6142BI, LM6144BI                         |                                     |     | 510 | 800 | $\mu A$   |
|                           |  |  | $T_A = -40^\circ C$ to $85^\circ C$ |     |     | 880 | $\mu A$   |

## 5.8 Electrical Characteristics: $V_S = 24V$

For  $V^+ = 24V$ ,  $V^- = 0V$ ,  $R_L > 1M\Omega$  connected to  $V_S / 2$ ,  $V_{CM} = V^+ / 2$ , and  $V_O = V^+ / 2$ , at  $T_A = 25^\circ C$ , unless otherwise noted.

| PARAMETER                 |  | TEST CONDITIONS                           |                                     | MIN  | TYP     | MAX        | UNIT |
|---------------------------|--|---|-------------------------------------|------|---------|------------|------|
| <b>OFFSET VOLTAGE</b>     |  |   |                                     |      |         |            |      |
| $V_{OS}$                  | Input offset voltage                     | LM6142AI, LM6144AI                        |                                     | 1.3  | 2       | mV         |      |
|                           |  |   | $T_A = -40^\circ C$ to $85^\circ C$ | 4.8  |         |            |      |
|                           |  | LM6142BI, LM6144BI                        |                                     | 1.3  | 3.8     |            |      |
|                           |  |   | $T_A = -40^\circ C$ to $85^\circ C$ | 4.8  |         |            |      |
| PSRR                      | Input offset voltage versus power supply | $0V \leq V_S \leq 24V$                    |                                     | 87   |         | dB         |      |
| <b>INPUT BIAS CURRENT</b> |  |   |                                     |      |         |            |      |
| $I_B$                     | Input bias current                       |   |                                     | 174  |         | nA         |      |
| $I_{OS}$                  | Input offset current                     |   |                                     | 5    |         | nA         |      |
| <b>INPUT VOLTAGE</b>      |  |   |                                     |      |         |            |      |
| $V_{CM}$                  | Common-mode input voltage range          |   |                                     | 0    | 24      | V          |      |
| CMRR                      | Common-mode rejection ratio              | $0V \leq V_{CM} \leq 23V$                 |                                     | 114  |         | dB         |      |
|                           |  | $0V \leq V_{CM} \leq 24V$                 |                                     | 100  |         |            |      |
| <b>INPUT IMPEDANCE</b>    |  |   |                                     |      |         |            |      |
| $R_{IN}$                  | Common-mode input resistance             |   |                                     | 288  |         | M $\Omega$ |      |
| <b>OPEN-LOOP GAIN</b>     |  |   |                                     |      |         |            |      |
| $A_{OL}$                  | Open-loop voltage gain                   | $R_L = 10k\Omega$                         |                                     | 500  |         | V/mV       |      |
| <b>NOISE</b>              |  |   |                                     |      |         |            |      |
| <b>FREQUENCY RESPONSE</b> |  |   |                                     |      |         |            |      |
| GBW                       | Gain-bandwidth product                   | $f = 50kHz$                               |                                     | 18   |         | MHz        |      |
| <b>OUTPUT</b>             |  |   |                                     |      |         |            |      |
| $V_O$                     | Voltage output swing                     | $R_L = 10k\Omega$ ,<br>From positive rail |                                     | 150  | 190     | mV         |      |
|                           |  |   | $T_A = -40^\circ C$ to $85^\circ C$ | 380  |         |            |      |
|                           |  | $R_L = 10k\Omega$ ,<br>From negative rail |                                     | 70   | 150     |            |      |
|                           |  |   | $T_A = -40^\circ C$ to $85^\circ C$ | 185  |         |            |      |
| <b>POWER SUPPLY</b>       |  |   |                                     |      |         |            |      |
| $I_Q$                     | Quiescent current per amplifier          | LM6142AI, LM6144AI                        |                                     | 750  | 1100    | $\mu A$    |      |
|                           |  |   | $T_A = -40^\circ C$ to $85^\circ C$ | 1150 |         |            |      |
|                           |  | LM6142BI, LM6144BI                        |                                     | 750  | 1100    | $\mu A$    |      |
|                           |  |   | $T_A = -40^\circ C$ to $85^\circ C$ | 1150 | $\mu A$ |            |      |

### 5.9 Typical Characteristics

at  $T_A = 25^\circ\text{C}$  and  $R_L = 10\text{ k}\Omega$  (unless otherwise noted)

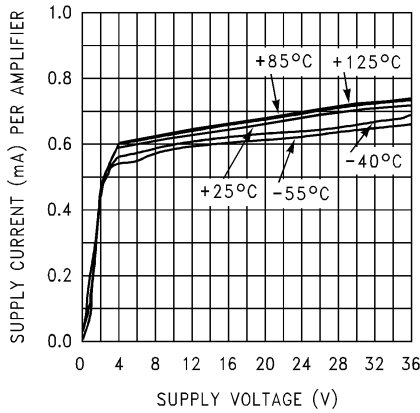

**Figure 5-1. Supply Current vs Supply Voltage**

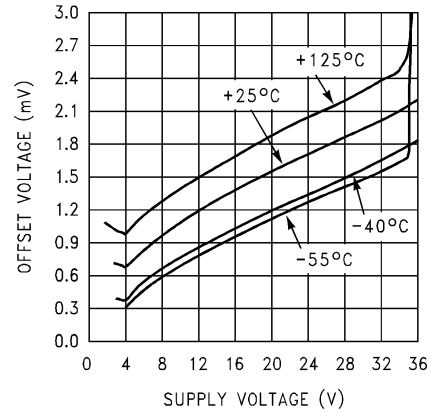

**Figure 5-2. Offset Voltage vs Supply Voltage**

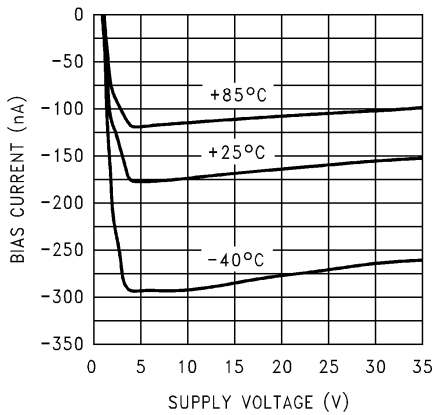

**Figure 5-3. Bias Current vs Supply Voltage**

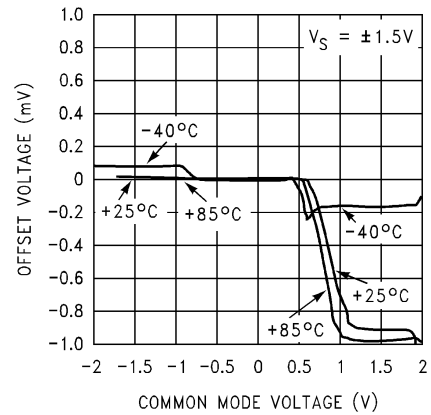

**Figure 5-4. Offset Voltage vs  $V_{CM}$**

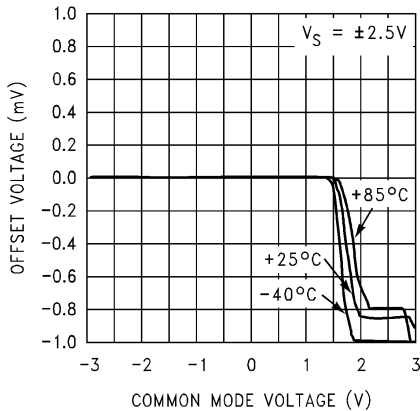

**Figure 5-5. Offset Voltage vs  $V_{CM}$**

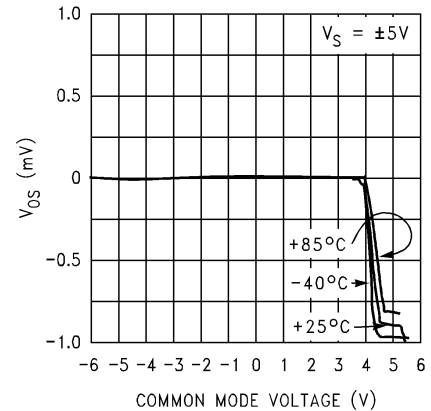

**Figure 5-6. Offset Voltage vs  $V_{CM}$**

### 5.9 Typical Characteristics (continued)

at  $T_A = 25^\circ\text{C}$  and  $R_L = 10\text{ k}\Omega$  (unless otherwise noted)

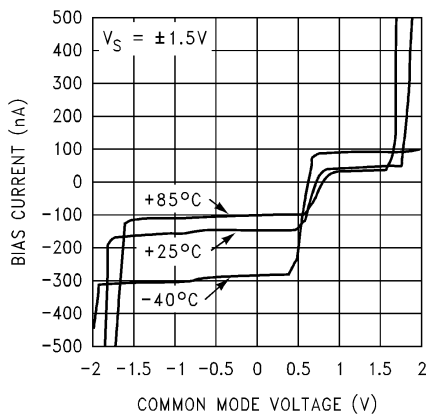

Figure 5-7. Bias Current vs  $V_{CM}$

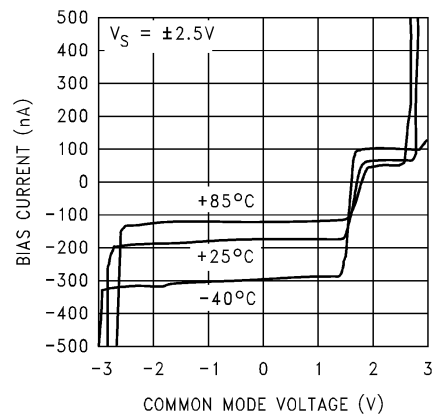

Figure 5-8. Bias Current vs  $V_{CM}$

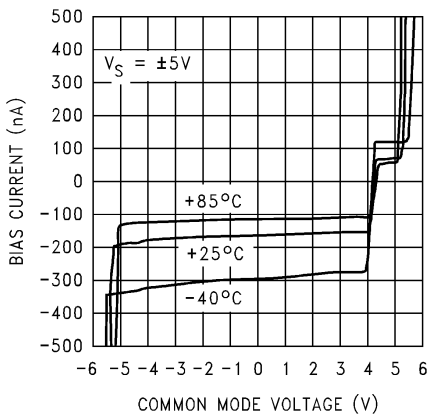

Figure 5-9. Bias Current vs  $V_{CM}$

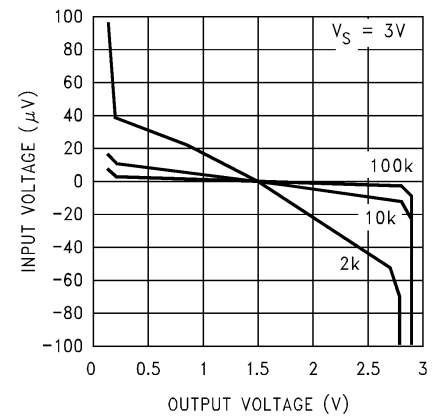

Figure 5-10. Open-Loop Transfer Function

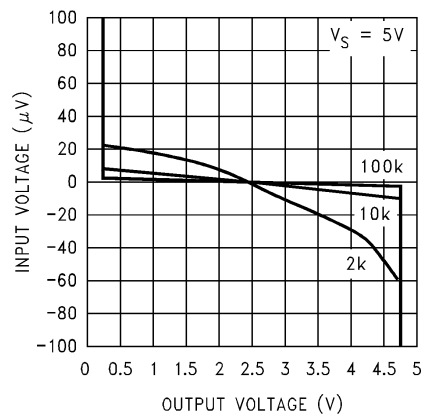

Figure 5-11. Open-Loop Transfer Function

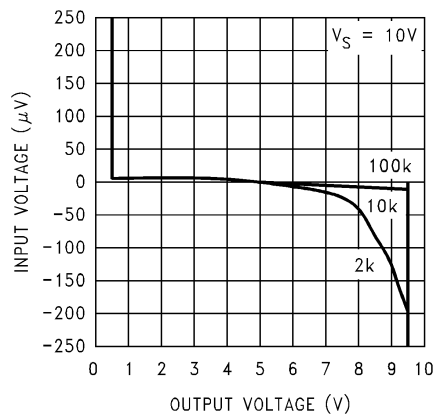
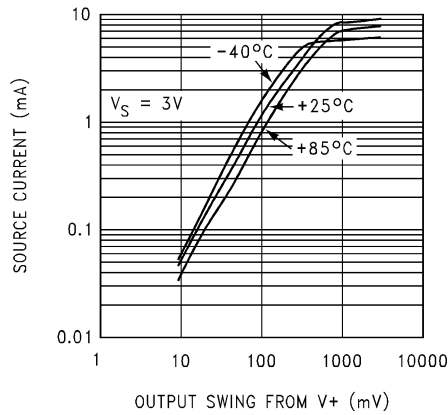

Figure 5-12. Open-Loop Transfer Function

### 5.9 Typical Characteristics (continued)

at  $T_A = 25^\circ\text{C}$  and  $R_L = 10\text{ k}\Omega$  (unless otherwise noted)



**Figure 5-13. Output Voltage vs Source Current**

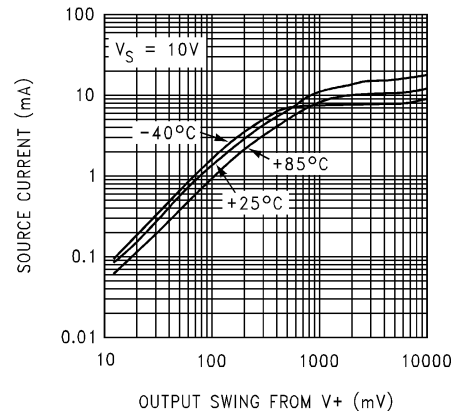

**Figure 5-14. Output Voltage vs Source Current**

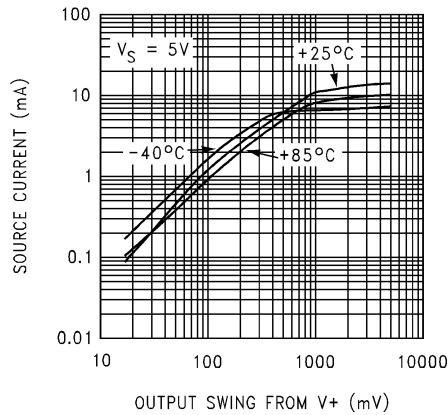

**Figure 5-15. Output Voltage vs Source Current**

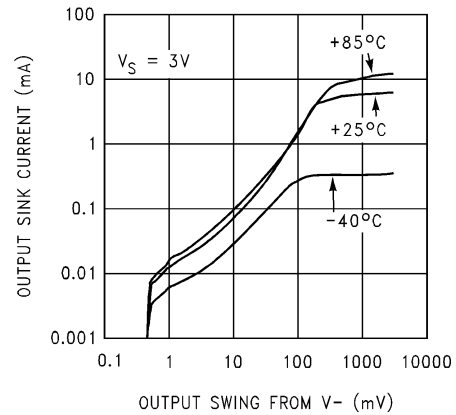

**Figure 5-16. Output Voltage vs Sink Current**

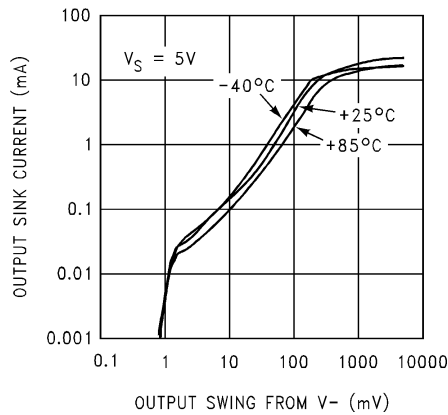

**Figure 5-17. Output Voltage vs Sink Current**

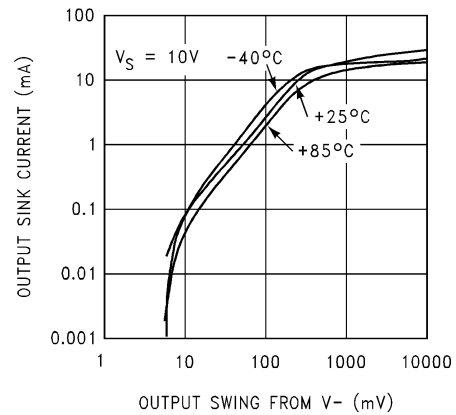

**Figure 5-18. Output Voltage vs Sink Current**

### 5.9 Typical Characteristics (continued)

at  $T_A = 25^\circ\text{C}$  and  $R_L = 10\text{ k}\Omega$  (unless otherwise noted)

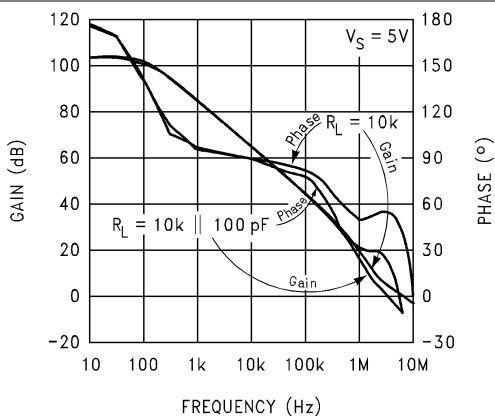

**Figure 5-19. Gain and Phase vs Load**

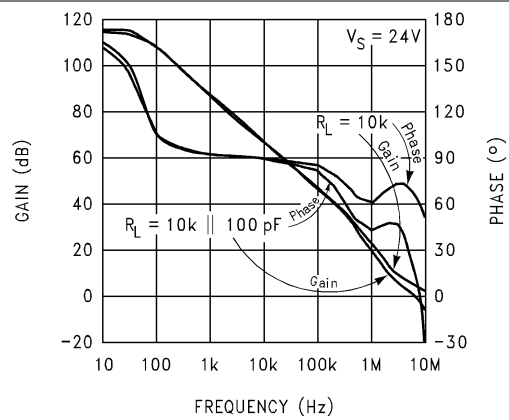

**Figure 5-20. Gain and Phase vs Load**

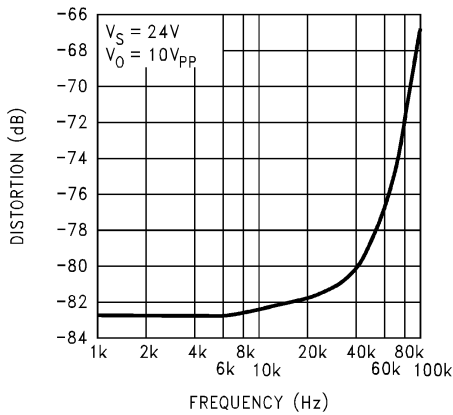

**Figure 5-21. Distortion + Noise vs Frequency**

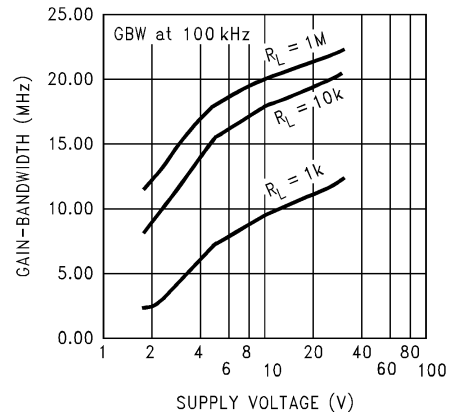

**Figure 5-22. GBW vs Supply**

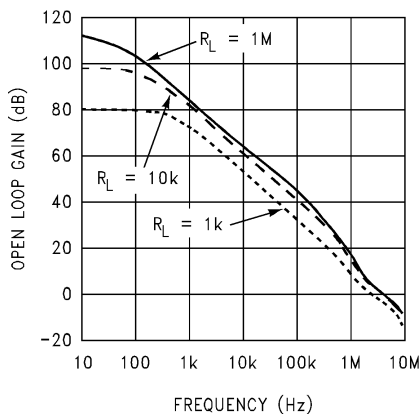

**Figure 5-23. Open Loop Gain vs Load, 3V Supply, Old Die**

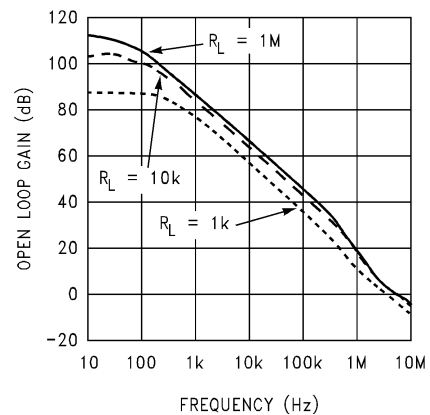

**Figure 5-24. Open Loop Gain vs Load, 5V Supply, Old Die**

### 5.9 Typical Characteristics (continued)

at  $T_A = 25^\circ\text{C}$  and  $R_L = 10\text{ k}\Omega$  (unless otherwise noted)

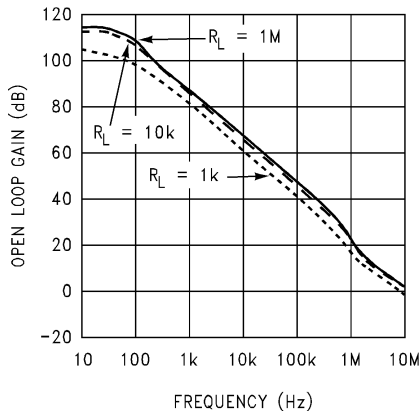

**Figure 5-25. Open Loop Gain vs Load, 24V Supply, Old Die**

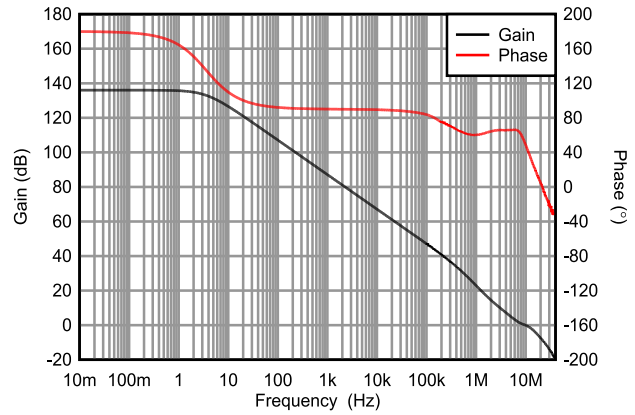

**Figure 5-26. Open Loop Gain vs Load, 5V Supply, New Die**

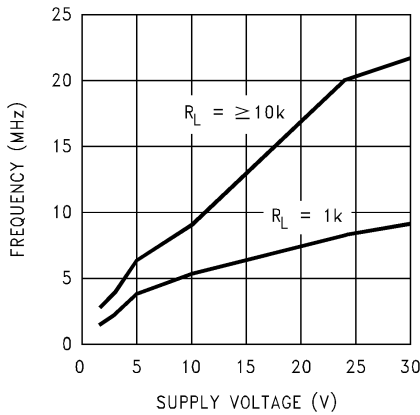

**Figure 5-27. Unity Gain Frequency vs  $V_S$**

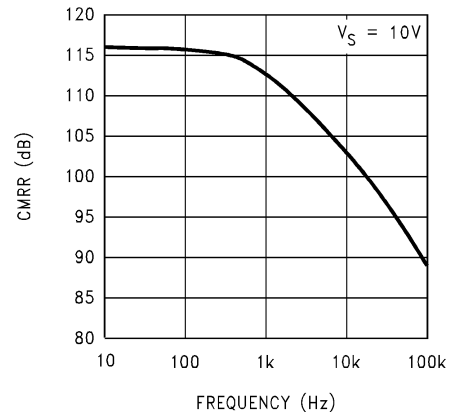

**Figure 5-28. CMRR vs Frequency, Old Die**

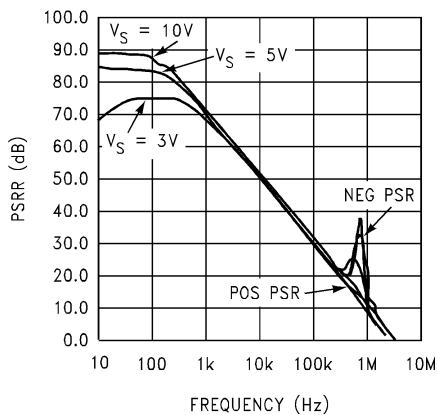

**Figure 5-29. PSRR vs Frequency, Old Die**

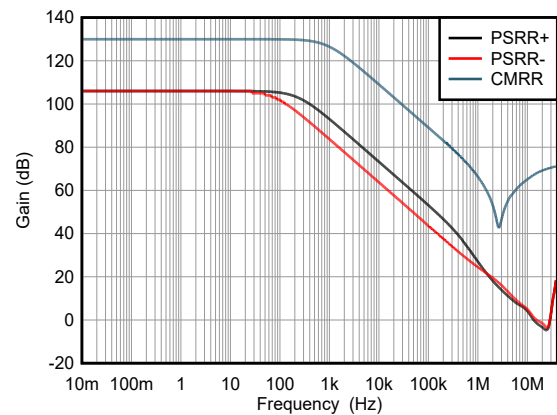

**Figure 5-30. CMRR and PSRR vs Frequency, New Die**

### 5.9 Typical Characteristics (continued)

at  $T_A = 25^\circ\text{C}$  and  $R_L = 10\text{ k}\Omega$  (unless otherwise noted)

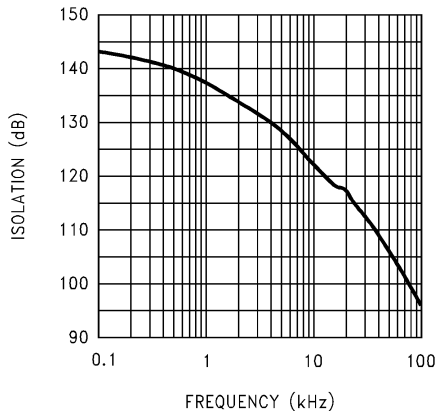

Figure 5-31. Crosstalk vs Frequency

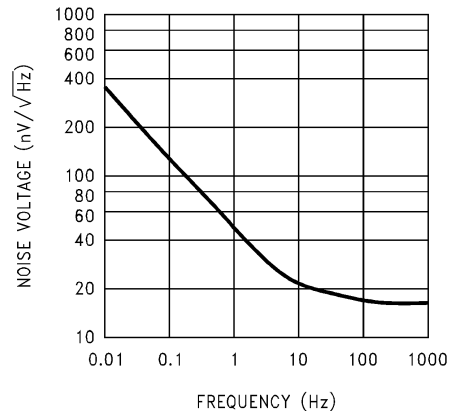

Figure 5-32. Noise Voltage vs Frequency

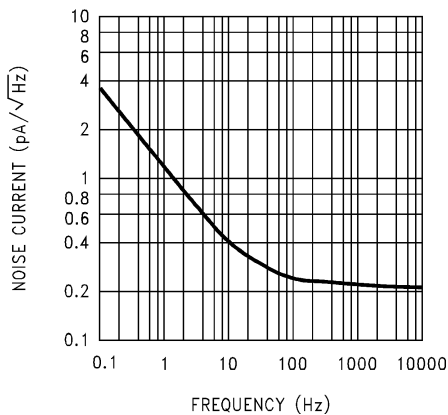

Figure 5-33. Noise Current vs Frequency

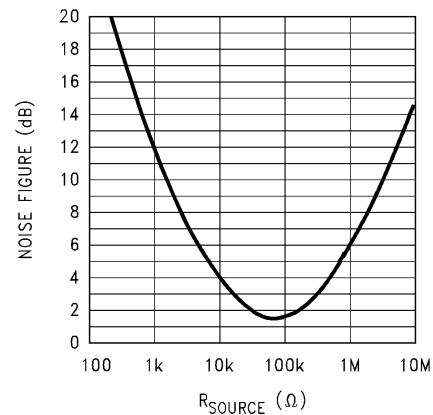

Figure 5-34. NF vs  $R_{SOURCE}$

### 5.10 Old Versus New Die Comparison

As of the publication of revision F of this data sheet, Texas Instruments has moved manufacturing of the die for LM6142 and LM6144 to a modern fabrication site. The two different die are referred to in this document as “old” (previous fabrication site) and “new” die. The die origin can be separated from the “Chip Source Origin” (CSO) parameter in the shipping information. The old die CSO is “GF6”, for the new die CSO is “RFB”. The old die information is maintained in this data sheet for comparison purposes, but all new manufacturing has moved to the new die.

Table 5-1. Old Versus New Die Comparison

| Description  | Old Die                         | New Die                        |
|--|---------------------------------|--------------------------------|
| Absolute maximum supply voltage                                    | 35V                             | 33V                            |
| Minimum supply voltage   | 1.8V                            | 2.7V                           |
| Typical/Minimum output voltage range for 100kΩ load ( $V_S = 5V$ ) | 0.005V - 4.995V / 0.01V - 4.98V | 0.045V - 4.97V / 0.05V - 4.96V |
| Typical output voltage range for 10kΩ load ( $V_S = 5V$ )          | 0.02V - 4.97V                   | 0.05V - 4.96V                  |
| Output voltage slew architecture                                   | Standard slew architecture      | Slew-boosted architecture      |

## 6 Application and Implementation

---

### Note

Information in the following applications sections is not part of the TI component specification, and TI does not warrant its accuracy or completeness. TI's customers are responsible for determining suitability of components for their purposes, as well as validating and testing their design implementation to confirm system functionality.

---

### 6.1 Application Information

The LM6142 brings a new level of ease of use to op amp system design.

With greater than rail-to-rail input voltage range concern over exceeding the common-mode voltage range is eliminated.

Rail-to-rail output swing provides the maximum possible dynamic range at the output. This is particularly important when operating on low supply voltages.

The high gain-bandwidth with low supply current opens new battery-powered applications, where high power consumption, previously reduced battery life to unacceptable levels.

To take advantage of these features, keep some ideas in mind.

### 6.2 Typical Applications

#### 6.2.1 FISH FINDER/ DEPTH SOUNDER.

The LM6142/LM6144 is an excellent choice for battery operated fish finders. The low supply current, high gain-bandwidth and full rail to rail output swing of the LM6142 provides an ideal combination for use in this and similar applications.

#### 6.2.2 ANALOG TO DIGITAL CONVERTER BUFFER

The high capacitive load driving ability, rail-to-rail input and output range with the excellent CMR of 82 dB, make the LM6142/LM6144 a good choice for buffering the inputs of A to D converters.

#### 6.2.3 3 OP AMP INSTRUMENTATION AMP WITH RAIL-TO-RAIL INPUT AND OUTPUT

Using the LM6144, a 3 op amp instrumentation amplifier with rail-to-rail inputs and rail to rail output can be made. These features make these instrumentation amplifiers an excellent choice for single supply systems.

Some manufacturers use a precision voltage divider array of 5 resistors to divide the common-mode voltage to get an input range of rail-to-rail or greater. The problem with this method is that the method also divides the signal, so to even get unity gain, the amplifier must be run at high closed loop gains. This raises the noise and drift by the internal gain factor and lowers the input impedance. Any mismatch in these precision resistors reduces the CMR as well. Using the LM6144, all of these problems are eliminated.

In this example, amplifiers A and B act as buffers to the differential stage ([Figure 6-1](#)). These buffers maintain that the input impedance is over 100M $\Omega$  and the buffers eliminate the requirement for precision matched resistors in the input stage. The buffers also maintain that the difference amp is driven from a voltage source. This is necessary to maintain the CMR set by the matching of R1–R2 with R3–R4.

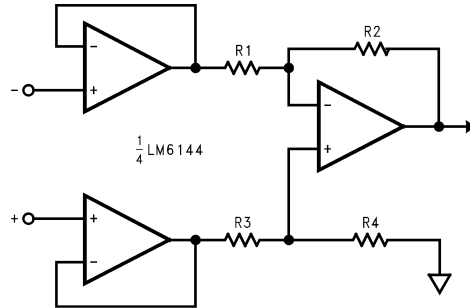

**Figure 6-1.**

The gain is set by the ratio of  $R2/R1$  and  $R3$  equals  $R1$  and  $R4$  equal  $R2$ . Making  $R4$  slightly smaller than  $R2$  and adding a trim pot equal to twice the difference between  $R2$  and  $R4$  allows the CMR to be adjusted for optimum.

With both rail to rail input and output ranges, the inputs and outputs are only limited by the supply voltages. Remember that even with rail-to-rail output, the output cannot swing past the supplies so the combined common mode voltage plus the signal must not be greater than the supplies or limiting occurs.

## 7 Device and Documentation Support

TI offers an extensive line of development tools. Tools and software to evaluate the performance of the device, generate code, and develop solutions are listed below.

### 7.1 Receiving Notification of Documentation Updates

To receive notification of documentation updates, navigate to the device product folder on [ti.com](http://ti.com). Click on *Notifications* to register and receive a weekly digest of any product information that has changed. For change details, review the revision history included in any revised document.

### 7.2 Support Resources

TI E2E™ [support forums](#) are an engineer's go-to source for fast, verified answers and design help — straight from the experts. Search existing answers or ask your own question to get the quick design help you need.

Linked content is provided "AS IS" by the respective contributors. They do not constitute TI specifications and do not necessarily reflect TI's views; see TI's [Terms of Use](#).

### Trademarks

TI E2E™ is a trademark of Texas Instruments.  
All trademarks are the property of their respective owners.

### 7.3 Electrostatic Discharge Caution



This integrated circuit can be damaged by ESD. Texas Instruments recommends that all integrated circuits be handled with appropriate precautions. Failure to observe proper handling and installation procedures can cause damage.

ESD damage can range from subtle performance degradation to complete device failure. Precision integrated circuits may be more susceptible to damage because very small parametric changes could cause the device not to meet its published specifications.

### 7.4 Glossary

[TI Glossary](#) This glossary lists and explains terms, acronyms, and definitions.

## 8 Revision History

NOTE: Page numbers for previous revisions may differ from page numbers in the current version.

| <b>Changes from Revision D (March 2013) to Revision E (May 2026)</b>  | <b>Page</b> |
|---|-------------|
| • Deleted "Swing 0.005V to 4.995V" in <i>Features</i> .....   | 1           |
| • Deleted "Small Signal, 5V/μs" in <i>Features</i> .....  | 1           |
| • Deleted "Large Signal, 30V/μs" in <i>Features</i> .....   | 1           |
| • Changed Slew Rate to Slew Rate: 30V/μs in <i>Features</i> .....   | 1           |
| • Changed supply range from 1.8V to 2.7V in <i>Features</i> .....   | 1           |
| • Changed from "Operating on supplies of 1.8V" to "Operating on supplies of 2.7V" .....                           | 1           |
| • Updated table note 1 of <i>Absolute Maximum Ratings</i> .....   | 5           |
| • Changed absolute maximum rating for supply voltage from 35V to 33V.....   | 5           |
| • Deleted absolute maximum rating for current at power supply pin.....  | 5           |
| • Updated table note 3 of <i>Absolute Maximum Ratings</i> .....   | 5           |
| • Changed absolute maximum rating for input (common-mode) voltage from (V±) ± 0.3V to (V±) ± 0.5V.....            | 5           |
| • Updated table note 4 of <i>Absolute Maximum Ratings</i> .....   | 5           |
| • Changed absolute maximum rating for differential input voltage from 15V to ±15V.....                            | 5           |
| • Updated table note 2 of <i>Absolute Maximum Ratings</i> .....   | 5           |
| • Changed absolute maximum rating for output current from ±25mA to Continuous.....                                | 5           |
| • Added absolute maximum rating for operating ambient temperature.....  | 5           |
| • Deleted absolute maximum rating for lead temperature.....   | 5           |
| • <i>Added ESD Ratings</i> table.....   | 5           |
| • Changed HBM ESD rating from 2500V to ±4000V.....  | 5           |
| • Changed minimum operating voltage from 1.8V to 2.7V.....  | 5           |
| • Deleted table note 1 on Operating Ratings.....  | 5           |
| • <i>Added Thermal Information</i> table for LM6142.....  | 6           |
| • Changed junction-to-ambient thermal resistance for LM6142D from 193°C/w to 127.1°C/W.....                       | 6           |
| • Changed junction-to-ambient thermal resistance for LM6142P from 115°C/w to 84.45°C/W.....                       | 6           |
| • Added junction-to-case thermal resistance for LM6142.....   | 6           |
| • Added junction-to-board thermal resistance for LM6142.....  | 6           |
| • Added junction-to-top characterization parameter for LM6142.....  | 6           |
| • Added junction-to-board characterization parameter for LM6142.....  | 6           |
| • <i>Added Thermal Information</i> table for LM6144.....  | 6           |
| • Changed junction-to-ambient thermal resistance for LM6144D from 126°C/W to 82.48°C/W.....                       | 6           |
| • Added junction-to-case (top) thermal resistance for LM6144.....   | 6           |
| • Added junction-to-board thermal resistance for LM6144.....  | 6           |
| • Added junction-to-top characterization parameter for LM6144.....  | 6           |
| • Added junction-to-board characterization parameter for LM6144.....  | 6           |
| • Updated all <i>Electrical Characteristics</i> tables to latest format.....                                      | 7           |
| • Updated Output Swing format to refer to rails.....  | 7           |
| • Changed typical voltage output swing for 100kΩ load from 4.995V to 30mV from positive rail.....                 | 7           |
| • Changed maximum voltage output swing for 100kΩ load from 4.98V to 40mV from positive rail.....                  | 7           |
| • Changed typical voltage output swing for 100kΩ load from 0.005V to 45mV from negative rail.....                 | 7           |
| • Changed maximum voltage output swing for 100kΩ load from 0.01V to 50mV from negative rail.....                  | 7           |
| • Changed maximum voltage output swing for 100kΩ load over temp range from 0.013V to 60mV from negative rail..... | 7           |
| • Changed typical voltage output swing for 10kΩ load from 4.97V to 40mV from positive rail.....                   | 7           |
| • Changed typical voltage output swing for 10kΩ load from 0.02V to 50mV from negative rail.....                   | 7           |
| • Deleted table notes for <i>Electrical Characteristics</i> tables.....   | 7           |
| • Updated Output Swing format to refer to rails.....  | 9           |
| • Changed maximum voltage output swing for 100kΩ load from 2.66V to 75mV from positive rail.....                  | 9           |
| • Updated Output Swing format to refer to rails.....  | 10          |

---

|  |    |
|--|----|
| • Added Open Loop Gain vs Load, for New Die.....                     | 11 |
| • Added CMRR and PSRR vs Frequency, for New Die.....                 | 11 |
| • Added a new sub-section <i>Old Versus New Die Comparison</i> ..... | 16 |
| • Deleted sub-section <i>Enhanced Slew Rate</i> .....                | 17 |

---

## 9 Mechanical, Packaging, and Orderable Information

The following pages include mechanical, packaging, and orderable information. This information is the most current data available for the designated devices. This data is subject to change without notice and revision of this document. For browser-based versions of this data sheet, refer to the left-hand navigation.

**PACKAGING INFORMATION**

| Orderable part number           | Status<br>(1) | Material type<br>(2) | Package   Pins | Package qty   Carrier | RoHS<br>(3) | Lead finish/<br>Ball material<br>(4) | MSL rating/<br>Peak reflow<br>(5) | Op temp (°C) | Part marking<br>(6) |
|---------------------------------|---------------|----------------------|----------------|-----------------------|-------------|--------------------------------------|-----------------------------------|--------------|---------------------|
| <a href="#">LM6142AIM/NOPB</a>  | Obsolete      | Production           | SOIC (D)   8   | -                     | -           | Call TI                              | Call TI                           | -40 to 85    | LM614<br>2AIM       |
| <a href="#">LM6142AIMX/NOPB</a> | Active        | Production           | SOIC (D)   8   | 2500   LARGE T&R      | Yes         | SN                                   | Level-1-260C-UNLIM                | -40 to 85    | LM614<br>2AIM       |
| LM6142AIMX/NOPB.A               | Active        | Production           | SOIC (D)   8   | 2500   LARGE T&R      | Yes         | SN                                   | Level-1-260C-UNLIM                | -40 to 85    | LM614<br>2AIM       |
| LM6142AIMX/NOPB.B               | Active        | Production           | SOIC (D)   8   | 2500   LARGE T&R      | Yes         | SN                                   | Level-1-260C-UNLIM                | -40 to 85    | LM614<br>2AIM       |
| <a href="#">LM6142BIM/NOPB</a>  | Obsolete      | Production           | SOIC (D)   8   | -                     | -           | Call TI                              | Call TI                           | -40 to 85    | LM614<br>2BIM       |
| <a href="#">LM6142BIMX/NOPB</a> | Active        | Production           | SOIC (D)   8   | 2500   LARGE T&R      | Yes         | SN                                   | Level-1-260C-UNLIM                | -40 to 85    | LM614<br>2BIM       |
| LM6142BIMX/NOPB.A               | Active        | Production           | SOIC (D)   8   | 2500   LARGE T&R      | Yes         | SN                                   | Level-1-260C-UNLIM                | -40 to 85    | LM614<br>2BIM       |
| LM6142BIMX/NOPB.B               | Active        | Production           | SOIC (D)   8   | 2500   LARGE T&R      | Yes         | SN                                   | Level-1-260C-UNLIM                | -40 to 85    | LM614<br>2BIM       |
| <a href="#">LM6142BIN/NOPB</a>  | Active        | Production           | PDIP (P)   8   | 40   TUBE             | Yes         | NIPDAU                               | Level-1-NA-UNLIM                  | -40 to 85    | LM6142<br>BIN       |
| LM6142BIN/NOPB.A                | Active        | Production           | PDIP (P)   8   | 40   TUBE             | Yes         | NIPDAU                               | Level-1-NA-UNLIM                  | -40 to 85    | LM6142<br>BIN       |
| LM6142BIN/NOPB.B                | Active        | Production           | PDIP (P)   8   | 40   TUBE             | Yes         | NIPDAU                               | Level-1-NA-UNLIM                  | -40 to 85    | LM6142<br>BIN       |
| <a href="#">LM6144AIM/NOPB</a>  | Obsolete      | Production           | SOIC (D)   14  | -                     | -           | Call TI                              | Call TI                           | -40 to 85    | LM6144<br>AIM       |
| <a href="#">LM6144AIMX/NOPB</a> | Active        | Production           | SOIC (D)   14  | 2500   LARGE T&R      | Yes         | SN                                   | Level-1-260C-UNLIM                | -40 to 85    | LM6144<br>AIM       |
| LM6144AIMX/NOPB.A               | Active        | Production           | SOIC (D)   14  | 2500   LARGE T&R      | Yes         | SN                                   | Level-1-260C-UNLIM                | -40 to 85    | LM6144<br>AIM       |
| <a href="#">LM6144BIM/NOPB</a>  | Obsolete      | Production           | SOIC (D)   14  | -                     | -           | Call TI                              | Call TI                           | -40 to 85    | LM6144<br>BIM       |
| <a href="#">LM6144BIMX/NOPB</a> | Active        | Production           | SOIC (D)   14  | 2500   LARGE T&R      | Yes         | SN                                   | Level-1-260C-UNLIM                | -40 to 85    | LM6144<br>BIM       |

| Orderable part number          | Status<br>(1) | Material type<br>(2) | Package   Pins | Package qty   Carrier | RoHS<br>(3) | Lead finish/<br>Ball material<br>(4) | MSL rating/<br>Peak reflow<br>(5) | Op temp (°C) | Part marking<br>(6) |
|--------------------------------|---------------|----------------------|----------------|-----------------------|-------------|--------------------------------------|-----------------------------------|--------------|---------------------|
| LM6144BIMX/NOPB.A              | Active        | Production           | SOIC (D)   14  | 2500   LARGE T&R      | Yes         | SN                                   | Level-1-260C-UNLIM                | -40 to 85    | LM6144<br>BIM       |
| <a href="#">LM6144BIN/NOPB</a> | Active        | Production           | PDIP (N)   14  | 25   TUBE             | Yes         | NIPDAU                               | Level-1-NA-UNLIM                  | -40 to 85    | LM6144BIN           |
| LM6144BIN/NOPB.A               | Active        | Production           | PDIP (N)   14  | 25   TUBE             | Yes         | NIPDAU                               | Level-1-NA-UNLIM                  | -40 to 85    | LM6144BIN           |

<sup>(1)</sup> **Status:** For more details on status, see our [product life cycle](#).

<sup>(2)</sup> **Material type:** When designated, preproduction parts are prototypes/experimental devices, and are not yet approved or released for full production. Testing and final process, including without limitation quality assurance, reliability performance testing, and/or process qualification, may not yet be complete, and this item is subject to further changes or possible discontinuation. If available for ordering, purchases will be subject to an additional waiver at checkout, and are intended for early internal evaluation purposes only. These items are sold without warranties of any kind.

<sup>(3)</sup> **RoHS values:** Yes, No, RoHS Exempt. See the [TI RoHS Statement](#) for additional information and value definition.

<sup>(4)</sup> **Lead finish/Ball material:** Parts may have multiple material finish options. Finish options are separated by a vertical ruled line. Lead finish/Ball material values may wrap to two lines if the finish value exceeds the maximum column width.

<sup>(5)</sup> **MSL rating/Peak reflow:** The moisture sensitivity level ratings and peak solder (reflow) temperatures. In the event that a part has multiple moisture sensitivity ratings, only the lowest level per JEDEC standards is shown. Refer to the shipping label for the actual reflow temperature that will be used to mount the part to the printed circuit board.

<sup>(6)</sup> **Part marking:** There may be an additional marking, which relates to the logo, the lot trace code information, or the environmental category of the part.

Multiple part markings will be inside parentheses. Only one part marking contained in parentheses and separated by a "~" will appear on a part. If a line is indented then it is a continuation of the previous line and the two combined represent the entire part marking for that device.

**Important Information and Disclaimer:** The information provided on this page represents TI's knowledge and belief as of the date that it is provided. TI bases its knowledge and belief on information provided by third parties, and makes no representation or warranty as to the accuracy of such information. Efforts are underway to better integrate information from third parties. TI has taken and continues to take reasonable steps to provide representative and accurate information but may not have conducted destructive testing or chemical analysis on incoming materials and chemicals. TI and TI suppliers consider certain information to be proprietary, and thus CAS numbers and other limited information may not be available for release.

In no event shall TI's liability arising out of such information exceed the total purchase price of the TI part(s) at issue in this document sold by TI to Customer on an annual basis.

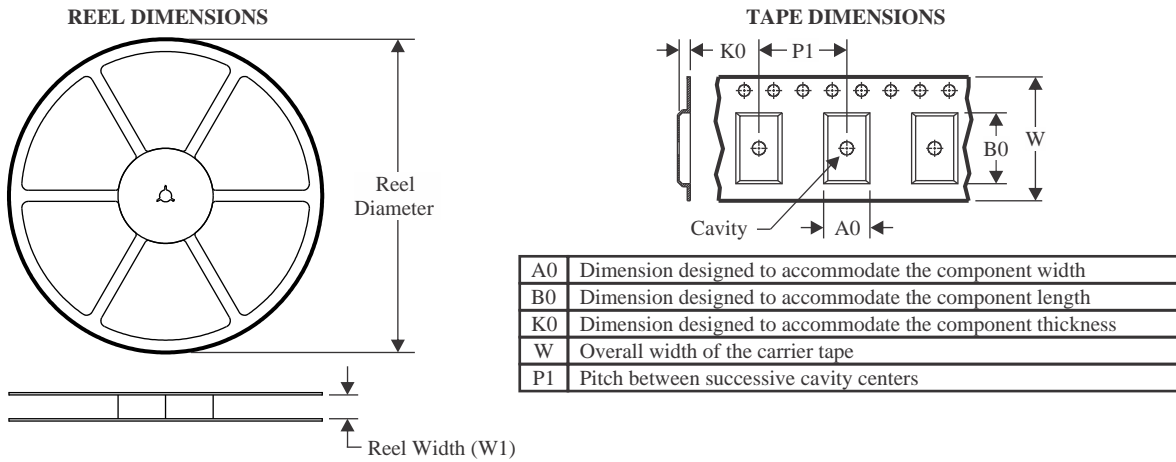
**TAPE AND REEL INFORMATION**

**QUADRANT ASSIGNMENTS FOR PIN 1 ORIENTATION IN TAPE**

\*All dimensions are nominal

| Device          | Package Type | Package Drawing | Pins | SPQ  | Reel Diameter (mm) | Reel Width W1 (mm) | A0 (mm) | B0 (mm) | K0 (mm) | P1 (mm) | W (mm) | Pin1 Quadrant |
|-----------------|--------------|-----------------|------|------|--------------------|--------------------|---------|---------|---------|---------|--------|---------------|
| LM6142AIMX/NOPB | SOIC         | D               | 8    | 2500 | 330.0              | 12.4               | 6.5     | 5.4     | 2.0     | 8.0     | 12.0   | Q1            |
| LM6142BIMX/NOPB | SOIC         | D               | 8    | 2500 | 330.0              | 12.4               | 6.5     | 5.4     | 2.0     | 8.0     | 12.0   | Q1            |
| LM6144AIMX/NOPB | SOIC         | D               | 14   | 2500 | 330.0              | 16.4               | 6.5     | 9.35    | 2.3     | 8.0     | 16.0   | Q1            |
| LM6144BIMX/NOPB | SOIC         | D               | 14   | 2500 | 330.0              | 16.4               | 6.5     | 9.35    | 2.3     | 8.0     | 16.0   | Q1            |

## TAPE AND REEL BOX DIMENSIONS



\*All dimensions are nominal

| Device          | Package Type | Package Drawing | Pins | SPQ  | Length (mm) | Width (mm) | Height (mm) |
|-----------------|--------------|-----------------|------|------|-------------|------------|-------------|
| LM6142AIMX/NOPB | SOIC         | D               | 8    | 2500 | 367.0       | 367.0      | 35.0        |
| LM6142BIMX/NOPB | SOIC         | D               | 8    | 2500 | 367.0       | 367.0      | 35.0        |
| LM6144AIMX/NOPB | SOIC         | D               | 14   | 2500 | 367.0       | 367.0      | 35.0        |
| LM6144BIMX/NOPB | SOIC         | D               | 14   | 2500 | 367.0       | 367.0      | 35.0        |

**TUBE**

\*All dimensions are nominal

| Device           | Package Name | Package Type | Pins | SPQ | L (mm) | W (mm) | T (μm) | B (mm) |
|------------------|--------------|--------------|------|-----|--------|--------|--------|--------|
| LM6142BIN/NOPB   | P            | PDIP         | 8    | 40  | 502    | 14     | 11938  | 4.32   |
| LM6142BIN/NOPB.A | P            | PDIP         | 8    | 40  | 502    | 14     | 11938  | 4.32   |
| LM6142BIN/NOPB.B | P            | PDIP         | 8    | 40  | 502    | 14     | 11938  | 4.32   |
| LM6144BIN/NOPB   | N            | PDIP         | 14   | 25  | 502    | 14     | 11938  | 4.32   |
| LM6144BIN/NOPB.A | N            | PDIP         | 14   | 25  | 502    | 14     | 11938  | 4.32   |



# D0014A

# PACKAGE OUTLINE

## SOIC - 1.75 mm max height

SMALL OUTLINE INTEGRATED CIRCUIT



4220718/A 09/2016

### NOTES:

1. All linear dimensions are in millimeters. Dimensions in parenthesis are for reference only. Dimensioning and tolerancing per ASME Y14.5M.
2. This drawing is subject to change without notice.
3. This dimension does not include mold flash, protrusions, or gate burrs. Mold flash, protrusions, or gate burrs shall not exceed 0.15 mm, per side.
4. This dimension does not include interlead flash. Interlead flash shall not exceed 0.43 mm, per side.
5. Reference JEDEC registration MS-012, variation AB.

# EXAMPLE BOARD LAYOUT

D0014A

SOIC - 1.75 mm max height

SMALL OUTLINE INTEGRATED CIRCUIT



LAND PATTERN EXAMPLE  
SCALE:8X



SOLDER MASK DETAILS

4220718/A 09/2016

NOTES: (continued)

- 6. Publication IPC-7351 may have alternate designs.
- 7. Solder mask tolerances between and around signal pads can vary based on board fabrication site.

# EXAMPLE STENCIL DESIGN

D0014A

SOIC - 1.75 mm max height

SMALL OUTLINE INTEGRATED CIRCUIT



SOLDER PASTE EXAMPLE  
BASED ON 0.125 mm THICK STENCIL  
SCALE:8X

4220718/A 09/2016

NOTES: (continued)

8. Laser cutting apertures with trapezoidal walls and rounded corners may offer better paste release. IPC-7525 may have alternate design recommendations.
9. Board assembly site may have different recommendations for stencil design.



D0008A

# PACKAGE OUTLINE

SOIC - 1.75 mm max height

SMALL OUTLINE INTEGRATED CIRCUIT



4214825/C 02/2019

### NOTES:

- Linear dimensions are in inches [millimeters]. Dimensions in parenthesis are for reference only. Controlling dimensions are in inches. Dimensioning and tolerancing per ASME Y14.5M.
- This drawing is subject to change without notice.
- This dimension does not include mold flash, protrusions, or gate burrs. Mold flash, protrusions, or gate burrs shall not exceed  $.006$  [0.15] per side.
- This dimension does not include interlead flash.
- Reference JEDEC registration MS-012, variation AA.

# EXAMPLE BOARD LAYOUT

D0008A

SOIC - 1.75 mm max height

SMALL OUTLINE INTEGRATED CIRCUIT



LAND PATTERN EXAMPLE  
 EXPOSED METAL SHOWN  
 SCALE:8X



SOLDER MASK DETAILS

4214825/C 02/2019

NOTES: (continued)

- 6. Publication IPC-7351 may have alternate designs.
- 7. Solder mask tolerances between and around signal pads can vary based on board fabrication site.

# EXAMPLE STENCIL DESIGN

D0008A

SOIC - 1.75 mm max height

SMALL OUTLINE INTEGRATED CIRCUIT



SOLDER PASTE EXAMPLE  
BASED ON .005 INCH [0.125 MM] THICK STENCIL  
SCALE:8X

4214825/C 02/2019

NOTES: (continued)

8. Laser cutting apertures with trapezoidal walls and rounded corners may offer better paste release. IPC-7525 may have alternate design recommendations.
9. Board assembly site may have different recommendations for stencil design.

P (R-PDIP-T8)

PLASTIC DUAL-IN-LINE PACKAGE



- NOTES:
- A. All linear dimensions are in inches (millimeters).
  - B. This drawing is subject to change without notice.
  - C. Falls within JEDEC MS-001 variation BA.

N (R-PDIP-T\*\*)

PLASTIC DUAL-IN-LINE PACKAGE

16 PINS SHOWN



4040049/E 12/2002

- NOTES:
- A. All linear dimensions are in inches (millimeters).
  - B. This drawing is subject to change without notice.
  - $\triangle C$  Falls within JEDEC MS-001, except 18 and 20 pin minimum body length (Dim A).
  - $\triangle D$  The 20 pin end lead shoulder width is a vendor option, either half or full width.

## IMPORTANT NOTICE AND DISCLAIMER

TI PROVIDES TECHNICAL AND RELIABILITY DATA (INCLUDING DATASHEETS), DESIGN RESOURCES (INCLUDING REFERENCE DESIGNS), APPLICATION OR OTHER DESIGN ADVICE, WEB TOOLS, SAFETY INFORMATION, AND OTHER RESOURCES "AS IS" AND WITH ALL FAULTS, AND DISCLAIMS ALL WARRANTIES, EXPRESS AND IMPLIED, INCLUDING WITHOUT LIMITATION ANY IMPLIED WARRANTIES OF MERCHANTABILITY, FITNESS FOR A PARTICULAR PURPOSE OR NON-INFRINGEMENT OF THIRD PARTY INTELLECTUAL PROPERTY RIGHTS.

These resources are intended for skilled developers designing with TI products. You are solely responsible for (1) selecting the appropriate TI products for your application, (2) designing, validating and testing your application, and (3) ensuring your application meets applicable standards, and any other safety, security, regulatory or other requirements.

These resources are subject to change without notice. TI grants you permission to use these resources only for development of an application that uses the TI products described in the resource. Other reproduction and display of these resources is prohibited. No license is granted to any other TI intellectual property right or to any third party intellectual property right. TI disclaims responsibility for, and you fully indemnify TI and its representatives against any claims, damages, costs, losses, and liabilities arising out of your use of these resources.

TI's products are provided subject to [TI's Terms of Sale](#), [TI's General Quality Guidelines](#), or other applicable terms available either on [ti.com](http://ti.com) or provided in conjunction with such TI products. TI's provision of these resources does not expand or otherwise alter TI's applicable warranties or warranty disclaimers for TI products. Unless TI explicitly designates a product as custom or customer-specified, TI products are standard, catalog, general purpose devices.

TI objects to and rejects any additional or different terms you may propose.

Copyright © 2026, Texas Instruments Incorporated

Last updated 10/2025