

LMK1C110x 1.8V、2.5V 和 3.3V LVCMOS 时钟缓冲器系列

1 特性

- 高性能 1:6 和 1:8 LVCMOS 时钟缓冲器
- 输出偏斜极低, < 55ps
- 附加抖动极低, 标称值 < 25fs
 - $V_{DD} = 3.3V$ 时, 典型值为 12fs
 - $V_{DD} = 2.5V$ 时, 典型值为 15fs
 - $V_{DD} = 1.8V$ 时, 典型值为 28fs
- 传播延迟极低, < 3ns
- 同步输出使能
- 电源电压: 3.3V、2.5V 或 1.8V
 - 在电源电压范围内输入端耐受 3.3V 电压
 - 失效防护输入
- 9000V HBM 的工业高 ESD 等级
- $f_{max} = 250MHz$ (3.3V)
- $f_{max} = 200MHz$ (2.5V 和 1.8V)
- 工作温度范围: $-40^{\circ}C$ 至 $125^{\circ}C$
- 采用 14 引脚和 16 引脚 TSSOP 封装

2 应用

- 工厂自动化与控制
- 电信设备
- 数据中心和企业计算
- 电网基础设施
- 电机驱动器
- 医疗成像

3 说明

LMK1C110x 是德州仪器 (TI) 的一款模块化、高性能、低偏斜、通用时钟缓冲器系列器件。整个系列采用模块化方法设计。提供五个不同的扇出选项: 1:2、1:3、1:4、1:6 和 1:8。

该系列所有器件均互相引脚兼容, 并与 CDCLVC110x 系列向后兼容, 从而易于处理。

该系列所有器件均具有相同的高性能特性, 如低附加抖动、低偏斜和宽工作温度范围。

LMK1C110x 具有同步输出使能控制端 (1G), 可在 1G 处于低电平时将输出切换为低电平状态。这些器件具有失效防护输入, 可防止在没有输入信号的情况下输出发生振荡并允许在提供 V_{DD} 之前提供输入信号。

LMK1C110x 系列可在 1.8V、2.5V 和 3.3V 电压下工作, 额定工作温度范围为 $-40^{\circ}C$ 至 $125^{\circ}C$ 。

器件信息

器件型号	封装	封装尺寸 (标称值)
LMK1C1106	TSSOP (14)	5.00mm x 4.40mm
LMK1C1108	TSSOP (16)	5.00mm x 4.40mm

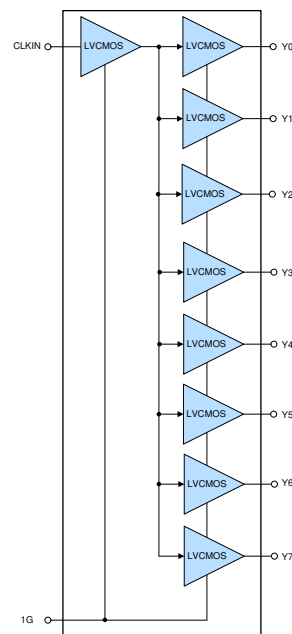

功能方框图



Table of Contents

1 特性	1	8.4 Device Functional Modes.....	11
2 应用	1	9 Application and Implementation	12
3 说明	1	9.1 Application Information.....	12
4 Revision History	2	9.2 Typical Application.....	12
5 Pin Configuration and Functions	3	10 Power Supply Recommendations	14
6 Specifications	4	11 Layout	15
6.1 Absolute Maximum Ratings.....	4	11.1 Layout Guidelines.....	15
6.2 ESD Ratings.....	4	11.2 Layout Example.....	15
6.3 Recommended Operating Conditions.....	4	12 Device and Documentation Support	16
6.4 Thermal Information.....	4	12.1 Documentation Support.....	16
6.5 Electrical Characteristics.....	5	12.2 接收文档更新通知.....	16
6.6 Timing Requirements.....	6	12.3 支持资源.....	16
6.7 Typical Characteristics.....	7	12.4 Trademarks.....	16
7 Parameter Measurement Information	8	12.5 Electrostatic Discharge Caution.....	16
8 Detailed Description	10	12.6 术语表.....	16
8.1 Overview.....	10	13 Mechanical, Packaging, and Orderable Information	16
8.2 Functional Block Diagram.....	10		
8.3 Feature Description.....	11		

4 Revision History

注：以前版本的页码可能与当前版本的页码不同

Changes from Revision * (December 2020) to Revision A (January 2022)	Page
• 向 <i>说明</i> 部分中添加失效防护输入详细信息.....	1
• 更改了第一页的重要图形.....	1
• Changed part-to-part skew maximum from 950 ps to 280 ps.....	5
• Added the <i>Fail-Safe Inputs</i> section.....	11

5 Pin Configuration and Functions



图 5-1. LMK1C1106 and LMK1C1108 PW Package 14-Pin TSSOP and 16-Pin TSSOP Top View

表 5-1. Pin Functions

PIN			TYPE	DESCRIPTION
NAME	LMK1C 1106	LMK1C 1108		
LVC MOS CLOCK INPUT				
CLKIN	1	1	Input	Single-ended clock input with internal 300-k Ω (typical) pulldown resistor to GND. Typically connected to a single-ended clock input.
CLOCK OUTPUT ENABLE				
1G	2	2	Input	Global Output Enable with internal 300-k Ω (typical) pulldown resistor to GND. Typically connected to VDD with external pullup resistor. HIGH: outputs enabled LOW: outputs disabled
LVC MOS CLOCK OUTPUT				
Y0	3	3	Output	LVC MOS output. Typically connected to a receiver. Unused outputs can be left floating.
Y1	14	16		
Y2	11	13		
Y3	13	15		
Y4	6	6		
Y5	9	11		
Y6	-	8		
Y7	-	9		
SUPPLY VOLTAGE				
VDD	5	5	Power	Power supply terminal. Typically connected to a 3.3-V, 2.5-V, or 1.8-V supply. The VDD pin is typically connected to an external 0.1- μ F capacitor near the pin.
	8	10		
	12	14		
GROUND				
GND	4	4	GND	Device ground.
	7	7		
	10	12		

6 Specifications

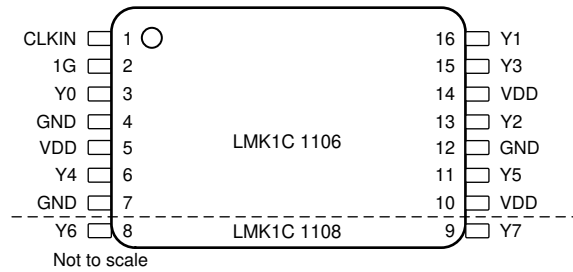
6.1 Absolute Maximum Ratings

over operating free-air temperature range (unless otherwise noted)⁽¹⁾

		MIN	MAX	UNIT
V _{DD}	Supply voltage	- 0.5	3.6	V
V _{CLKIN}	Input voltage (CLKIN)			
V _{IN}	Input voltage (1G)			
V _{Yn}	Output pins (Yn)	- 0.5	V _{DD} + 0.3	
I _{IN}	Input current	- 20	20	mA
I _O	Continuous output current	- 50	50	mA
T _{stg}	Storage temperature	- 65	150	°C

- (1) Operation outside the *Absolute Maximum Ratings* may cause permanent device damage. *Absolute Maximum Ratings* do not imply functional operation of the device at these or any other conditions beyond those listed under *Recommended Operating Conditions*. If used outside the *Recommended Operating Conditions* but within the *Absolute Maximum Ratings*, the device may not be fully functional, and this may affect device reliability, functionality, performance, and shorten the device lifetime.

6.2 ESD Ratings

			VALUE	UNIT
V _(ESD)	Electrostatic discharge	Human body model (HBM), per ANSI/ESDA/ JEDEC JS-001, all pins ⁽¹⁾	±9000	V
		Charged device model (CDM), per JEDEC specification JESD22-C101, all pins ⁽²⁾	±1500	

- (1) JEDEC document JEP155 states that 500-V HBM allows safe manufacturing with a standard ESD control process.

- (2) JEDEC document JEP157 states that 250-V CDM allows safe manufacturing with a standard ESD control process.

6.3 Recommended Operating Conditions

over operating free-air temperature range (unless otherwise noted)

			MIN	NOM	MAX	UNIT
V _{DD}	Core supply voltage	3.3-V supply	3.135	3.3	3.465	V
		2.5-V supply	2.375	2.5	2.625	
		1.8-V supply	1.71	1.8	1.89	
T _A	Operating free-air temperature		- 40		125	°C
T _J	Operating junction temperature		- 40		150	°C

6.4 Thermal Information

THERMAL METRIC ⁽¹⁾		LMK1C1106	LMK1C1108	UNIT
		PW (TSSOP)	PW(TSSOP)	
		14 PINS	16 PINS	
R _{qJA}	Junction-to-ambient thermal resistance	114.4	123.4	°C/W
R _{qJC(top)}	Junction-to-case (top) thermal resistance	45.2	53.1	°C/W
R _{qJB}	Junction-to-board thermal resistance	60.6	66.4	°C/W
Y _{JT}	Junction-to-top characterization parameter	5.9	8.9	°C/W
Y _{JB}	Junction-to-board characterization parameter	60	65.8	°C/W

- (1) For more information about traditional and new thermal metrics, see the [Semiconductor and IC Package Thermal Metrics](#) application report.

6.5 Electrical Characteristics

V_{DD} = 3.3 V ± 5%, -40°C ≤ TA ≤ 125°C. Typical values are at V_{DD} = 3.3 V, 25°C (unless otherwise noted)

PARAMETER		TEST CONDITIONS	MIN	TYP	MAX	UNIT
CURRENT CONSUMPTION						
I _{DD}	Core supply current, static	All-outputs disabled, f _{IN} = 0 V		25	45	μA
I _{DD}	Core supply current	All-outputs disabled, f _{IN} = 100 MHz, V _{DD} = 1.8 V		2	6	mA
I _{DD}	Core supply current	All-outputs disabled, f _{IN} = 100 MHz, V _{DD} = 2.5 V		6.5	10	mA
I _{DD}	Core supply current	All-outputs disabled, f _{IN} = 100 MHz, V _{DD} = 3.3 V		15	21	mA
I _{DD}	Output current	Per output, f _{IN} = 100 MHz, C _L = 5pF, V _{DD} = 1.8 V		3.2	3.5	
		Per output, f _{IN} = 100 MHz, C _L = 5pF, V _{DD} = 2.5 V		4.6	5.5	
		Per output, f _{IN} = 100 MHz, C _L = 5pF, V _{DD} = 3.3 V		6	7	
CLOCK INPUT						
f _{IN_SE}	Input frequency	V _{DD} = 3.3 V	DC		250	MHz
		V _{DD} = 2.5 V and 1.8 V	DC		200	
V _{IH}	Input high voltage		0.7 x V _{DD}			V
V _{IL}	Input low voltage				0.3 x V _{DD}	
dV _{IN} /dt	Input slew rate	20% - 80% of input swing	0.1			V/ns
I _{IN_LEAK}	Input leakage current		-50		50	μA
C _{IN_SE}	Input capacitance	at 25°C		7		pF
CLOCK OUTPUT FOR ALL V_{DD} LEVELS						
f _{OUT}	Output frequency	V _{DD} = 3.3 V			250	MHz
		V _{DD} = 2.5 V and 1.8 V			200	
ODC	Output duty cycle	With 50% duty cycle input	45		55	%
t _{1G_ON}	Output enable time	See (1)			5	cycles
t _{1G_OFF}	Output disable time	See (2)			5	cycles
CLOCK OUTPUT FOR V_{DD} = 3.3 V ± 5%						
V _{OH}	Output high voltage	I _{OH} = 1 mA	2.8			V
V _{OL}	Output low voltage	I _{OL} = 1 mA			0.2	
t _{RISE-FALL}	Output rise and fall time	20/80%, C _L = 5 pF, f _{IN} = 156.25 MHz		0.3	0.7	ns
t _{OUTPUT-SKEW}	Output-output skew	See (3)		35	55	ps
t _{PART-SKEW}	Part-to-part skew				280	
t _{PROP-DELAY}	Propagation delay	See (4)		1.3	2.2	ns
t _{JITTER-ADD}	Additive Jitter	f _{IN} = 156.25 MHz, Input slew rate = 1.6 V/ns, Integration range = 12 kHz - 20 MHz		12	20	fs, RMS
R _{OUT}	Output impedance			50		Ω
CLOCK OUTPUT FOR V_{DD} = 2.5 V ± 5%						
V _{OH}	Output high voltage	I _{OH} = 1 mA	0.8 x V _{DD}			V
V _{OL}	Output low voltage	I _{OL} = 1 mA			0.2 x V _{DD}	
t _{RISE-FALL}	Output rise and fall time	20/80%, C _L = 5 pF, f _{IN} = 156.25 MHz		0.33	0.8	ns
t _{OUTPUT-SKEW}	Output-output skew	See (3)			55	ps
t _{PART-SKEW}	Part-to-part skew				450	
t _{PROP-DELAY}	Propagation delay	See (4)		1.5	2.5	ns

LMK1C1106, LMK1C1108

ZHCSSL7A - DECEMBER 2020 - REVISED JANUARY 2022

VDD = 3.3 V ± 5 %, - 40°C ≤ TA ≤ 125°C. Typical values are at VDD = 3.3 V, 25°C (unless otherwise noted)

PARAMETER		TEST CONDITIONS	MIN	TYP	MAX	UNIT
t _{JITTER-ADD}	Additive Jitter	f _{IN} = 156.25 MHz, Input slew rate = 1.2 V/ns, Integration range = 12 kHz - 20 MHz		15	27	fs, RMS
R _{OUT}	Output impedance			55		Ω
CLOCK OUTPUT FOR V_{DD} = 1.8 V ± 5%						
V _{OH}	Output high voltage	I _{OH} = 1 mA	0.8 x V _{DD}			V
V _{OL}	Output low voltage	I _{OL} = 1 mA	0.2 x V _{DD}			
t _{RISE-FALL}	Output rise and fall time	20/80%, C _L = 5 pF, f _{IN} = 156.25 MHz		0.38	1	ns
t _{OUTPUT-SKEW}	Output-output skew	See (3)			55	ps
t _{PART-SKEW}	Part-to-part skew				930	ps
t _{PROP-DELAY}	Propagation delay	See (4)		1.5	3	ns
t _{JITTER-ADD}	Additive Jitter	f _{IN} = 156.25 MHz, Input slew rate = 1.2 V/ns, Integration range = 12 kHz - 20 MHz		28	60	fs, RMS
R _{OUT}	Output impedance			64		Ω
GENERAL PURPOSE INPUT (1G)						
V _{IH}	High-level input voltage		0.75 x V _{DD}			V
V _{IL}	Low-level input voltage		0.25 x V _{DD}			
I _{IH}	Input high-level current	V _{IH} = V _{DD_REF}	- 50		50	μA
I _{IL}	Input low-level current	V _{IL} = GND	- 50		50	

- (1) Measured from 1G rising edge crossing V_{IH} to first rising edge of Y_n.
- (2) Measured from 1G falling edge crossing V_{IL} to last falling edge of Y_n.
- (3) Measured from rising edge of any Y_n output to any other Y_m output.
- (4) Measured from rising edge of CLKIN to any Y_n output.

6.6 Timing Requirements

VDD = 3.3 V ± 5 %, - 40°C ≤ TA ≤ 125°C

		MIN	NOM	MAX	UNIT
POWER SUPPLY					
V/t _{RAMP}	V _{DD} ramp rate	0.1		50	V/ms

6.7 Typical Characteristics

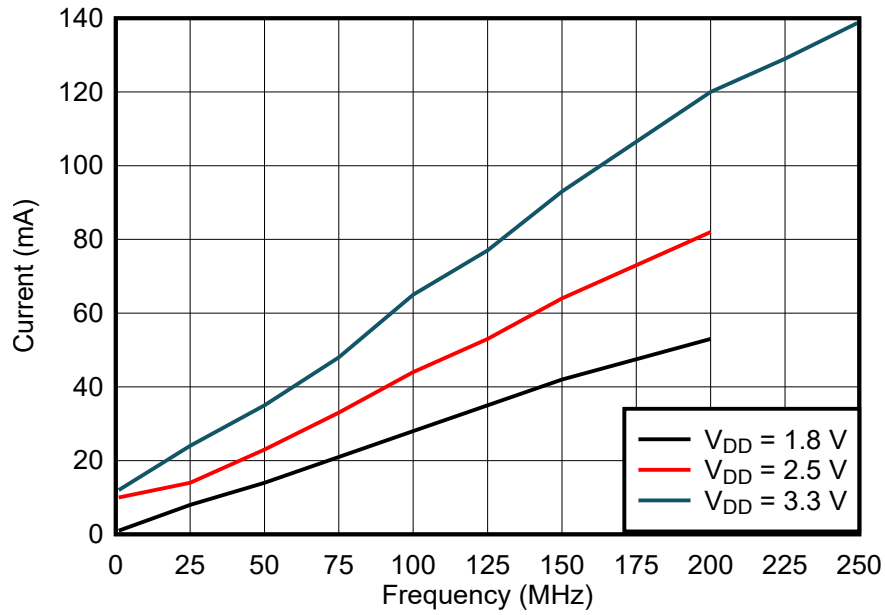

Device Power Consumption vs. Clock Frequency (Load 5 pF)

7 Parameter Measurement Information



图 7-1. Test Load Circuit



图 7-2. Application Load With 50- Ω Termination

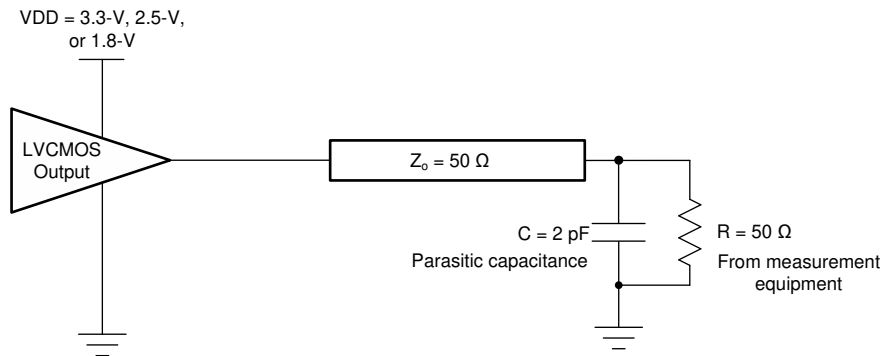

图 7-3. Application Load With Termination

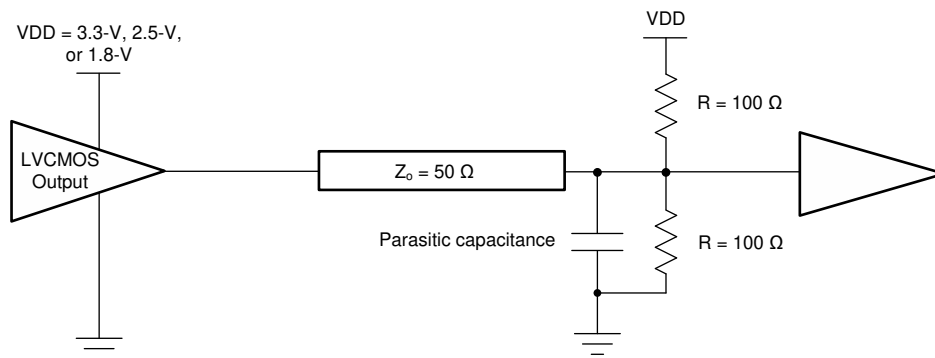

图 7-4. t_{1G_ON} Output Enable Time

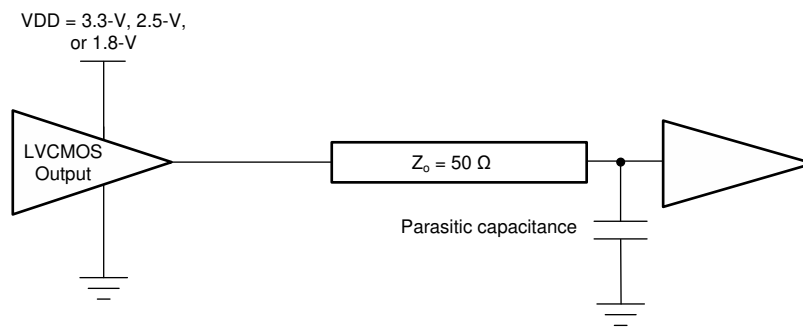

图 7-5. t_{1G_OFF} Output Disable Time

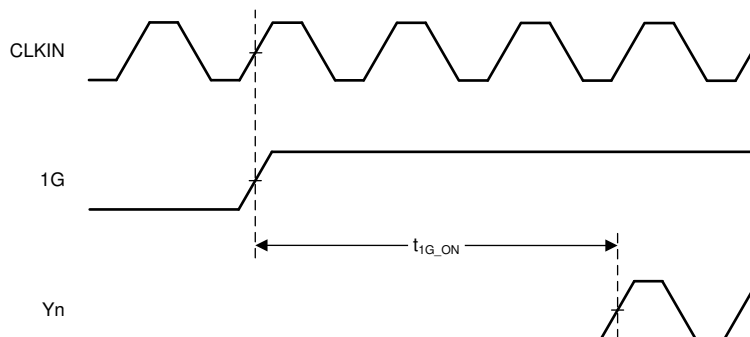

图 7-6. Propagation Delay $t_{PROP-DELAY}$ and Output Skew $t_{OUTPUT-SKEW}$

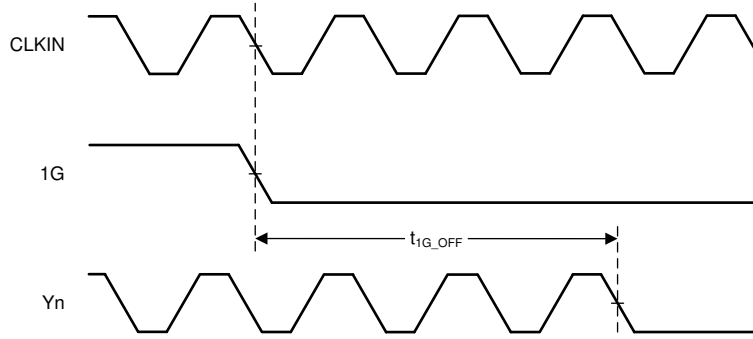

图 7-7. Rise and Fall Time $t_{RISE-FALL}$

8 Detailed Description

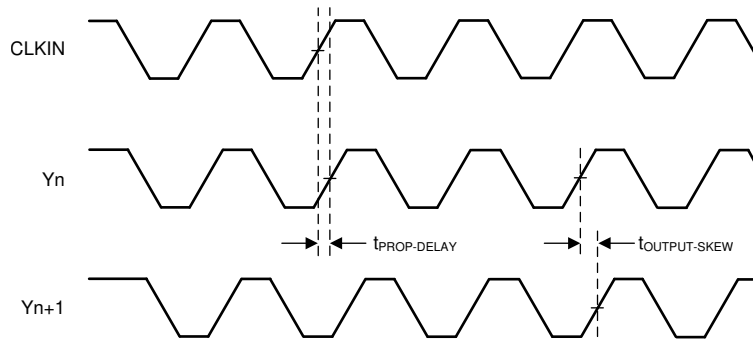
8.1 Overview

The LMK1C110x family of devices is part of a low-jitter and low-skew LVCMOS fan-out buffer solution. For best signal integrity, it is important to match the characteristic impedance of the LMK1C110x's output driver with that of the transmission line.

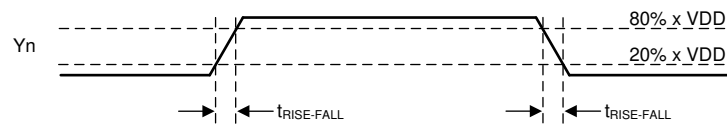
8.2 Functional Block Diagram

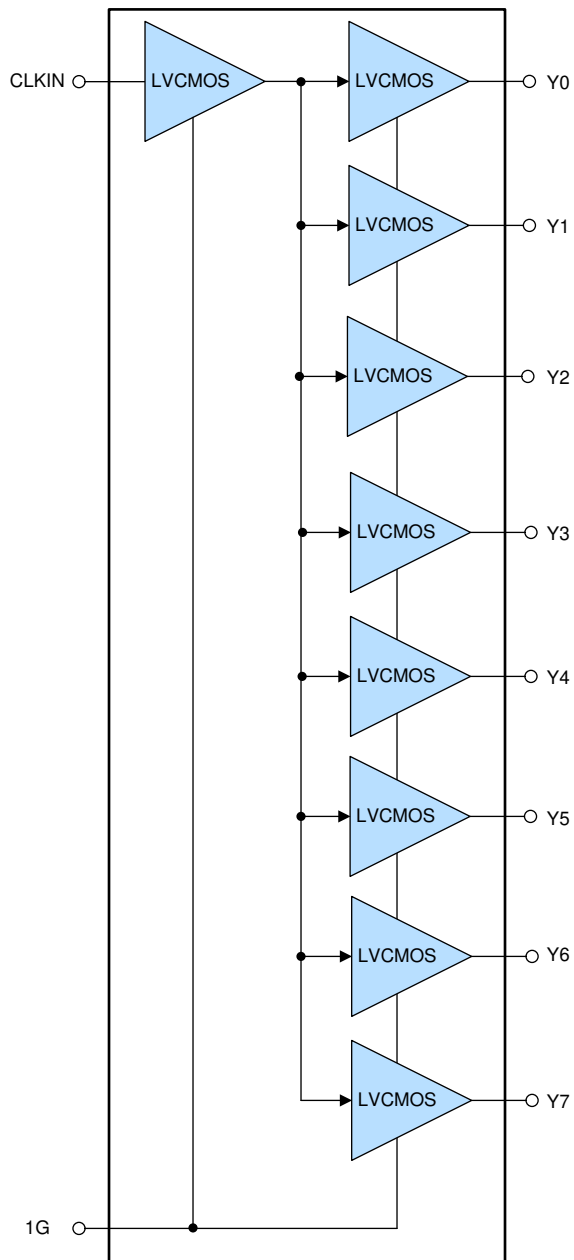

8.3 Feature Description

The outputs of the LMK1C110x can be disabled by driving the synchronous output enable pin (1G) low. Unused output can be left floating to reduce overall system component cost. Supply and ground pins must be connected to V_{DD} and GND, respectively.

8.3.1 Fail-Safe Inputs

The LMK1C110x family of devices is designed to support fail-safe input operation. This feature allows the user to drive the device inputs before VDD is applied without damaging the device. Refer to [Absolute Maximum Ratings](#) for more information on the maximum input supported by the device. The device also incorporates an input hysteresis that prevents random oscillation in absence of an input signal, allowing the input pins to be left open.

8.4 Device Functional Modes

The LMK1C110x operates from 1.8-V, 2.5-V, or 3.3-V supplies. [表 8-1](#) shows the output logics of the LMK1C110x.

表 8-1. Output Logic Table

INPUTS		OUTPUTS
CLKIN	1G	Yn
X	L	L
L	H	L
H	H	H

9 Application and Implementation

备注

以下应用部分中的信息不属于 TI 器件规格的范围，TI 不担保其准确性和完整性。TI 的客户应负责确定器件是否适用于其应用。客户应验证并测试其设计，以确保系统功能。

9.1 Application Information

The LMK1C110x family is a low additive jitter LVCMOS buffer solution that can operate up to 250-MHz at $V_{DD} = 3.3\text{ V}$ and 200 MHz at $V_{DD} = 2.5\text{ V}$ to 1.8 V. Low output skew as well as the ability for synchronous output enable is featured to simultaneously enable or disable buffered clock outputs as necessary in the application.

9.2 Typical Application



图 9-1. System Configuration Example

9.2.1 Design Requirements

The LMK1C110x shown in 图 9-1 is configured to fan out a 100-MHz signal from a local LVCMOS oscillator. The CPU is configured to control the output state through 1G.

The configuration example is driving three LVCMOS receivers in a backplane application with the following properties:

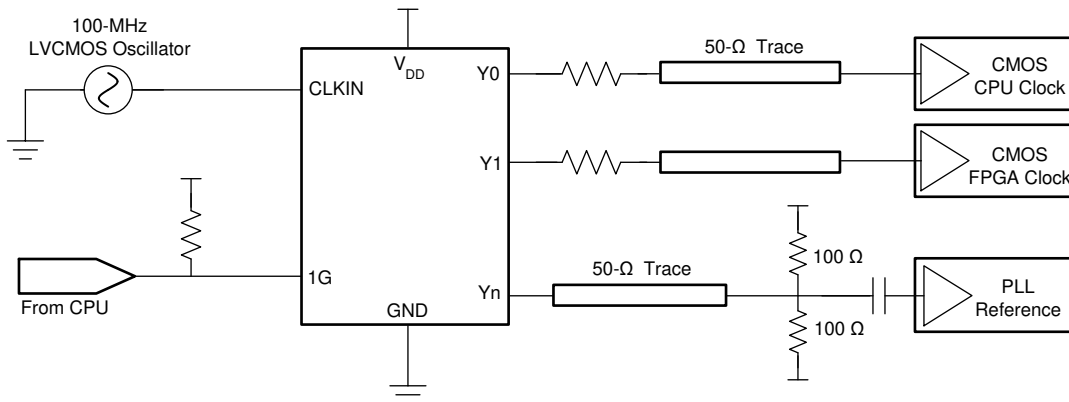
- The CPU clock can accept a full swing DC-coupled LVCMOS signal. A series resistor is placed near the LMK1C110x to closely match the characteristic impedance of the trace to minimize reflections.
- The FPGA clock is similarly DC-coupled with an appropriate series resistor placed near the LMK1C110x.
- The PLL in this example can accept a lower amplitude signal, so a Thevenin's equivalent termination is used. The PLL receiver features internal biasing, so AC coupling can be used when common-mode voltage is mismatched.

9.2.2 Detailed Design Procedure

Unused outputs can be left floating. See [Power Supply Recommendations](#) for recommended filtering techniques.

9.2.3 Application Curves

The low additive jitter of the LMK1C110x is shown in 图 9-2.

图 9-3 shows the low-noise 156.25-MHz reference source with 24.8-fs RMS jitter driving the LMK1C110x, resulting in 27.3-fs RMS jitter when integrated from 12 kHz to 20 MHz at 3.3-V supply. The resultant additive jitter measured is a low 11.4-fs RMS for this configuration.

图 9-4 shows the low-noise 156.25-MHz reference source with 24.8-fs RMS jitter driving the LMK1C110x, resulting in 29-fs RMS jitter when integrated from 12 kHz to 20 MHz at 2.5-V supply. The resultant additive jitter measured is a low 15-fs RMS for this configuration.

图 9-5 shows the low-noise 156.25-MHz reference source with 24.8-fs RMS jitter driving the LMK1C110x, resulting in 34-fs RMS jitter when integrated from 12 kHz to 20 MHz at 1.8-V supply. The resultant additive jitter measured is a low 23.25-fs RMS for this configuration.



图 9-2. LMK1C110x Reference Phase Noise 24.8-fs (12 kHz to 20 MHz)



图 9-3. LMK1C110x 3.3-V Output Phase Noise 27.3-fs (12 kHz to 20 MHz)

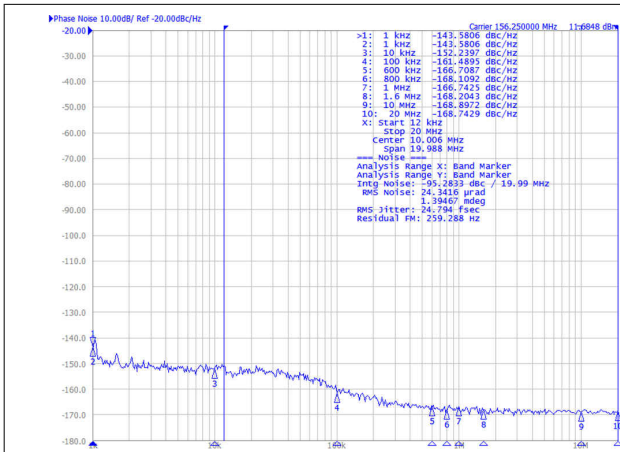

图 9-4. LMK1C110x 2.5-V Output Phase Noise 29-fs (12 kHz to 20 MHz)

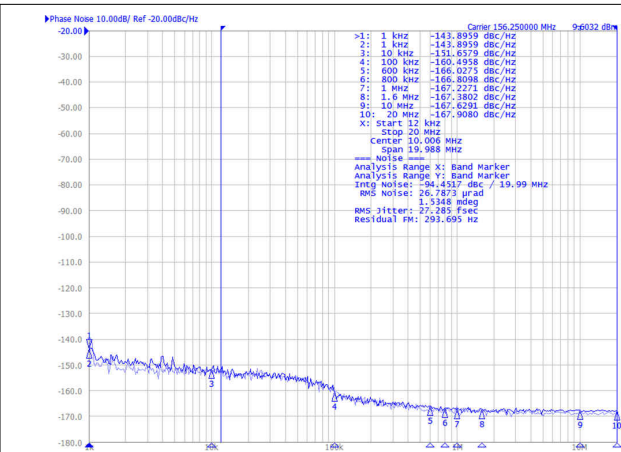

图 9-5. LMK1C110x 1.8-V Output Phase Noise 34-fs (12 kHz to 20 MHz)

10 Power Supply Recommendations

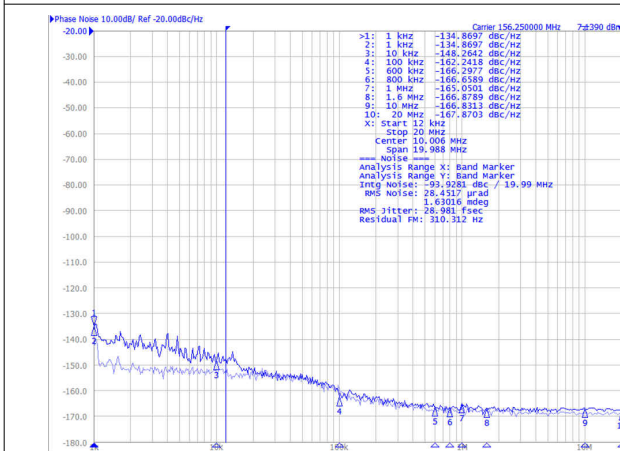
High-performance clock buffers can be sensitive to noise on the power supply, which may dramatically increase the additive jitter of the buffer. Thus, it is essential to manage any excessive noise from the system power supply, especially for applications where the jitter and phase noise performance is critical.

Filter capacitors are used to eliminate the low-frequency noise from the power supply, where the bypass capacitors provide the very low impedance path for high-frequency noise and guard the power supply system against induced fluctuations. These bypass capacitors also provide instantaneous current surges as required by the device and should have low equivalent series resistance (ESR). To properly bypass the supply, the decoupling capacitors must be placed very close to the power-supply terminals, be connected directly to the ground plane, and laid out with short loops to minimize inductance. TI recommends adding as many high-frequency (for example, 0.1 μF) bypass capacitors, as there are supply terminals in the package. TI recommends, but does not require, inserting a ferrite bead between the board power supply and the chip power supply that isolates the high-frequency switching noises generated by the clock buffer; these beads prevent the switching noise from leaking into the board supply. It is imperative to choose an appropriate ferrite bead with very low DC resistance to provide adequate isolation between the board supply and the chip supply, as well as to maintain a voltage at the supply terminals that is greater than the minimum voltage required for proper operation.

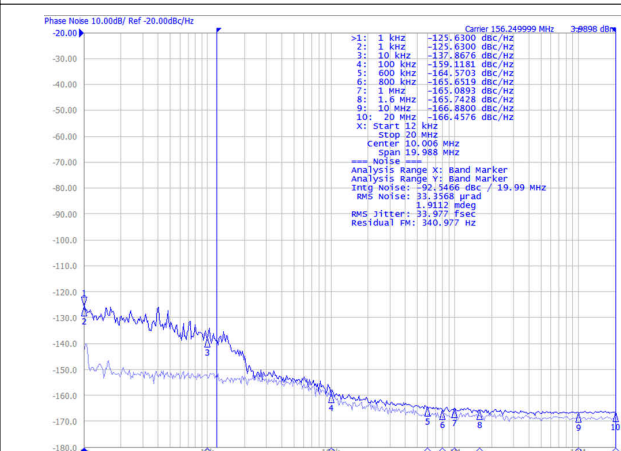
Figure 10-1 shows this recommended power supply decoupling method.

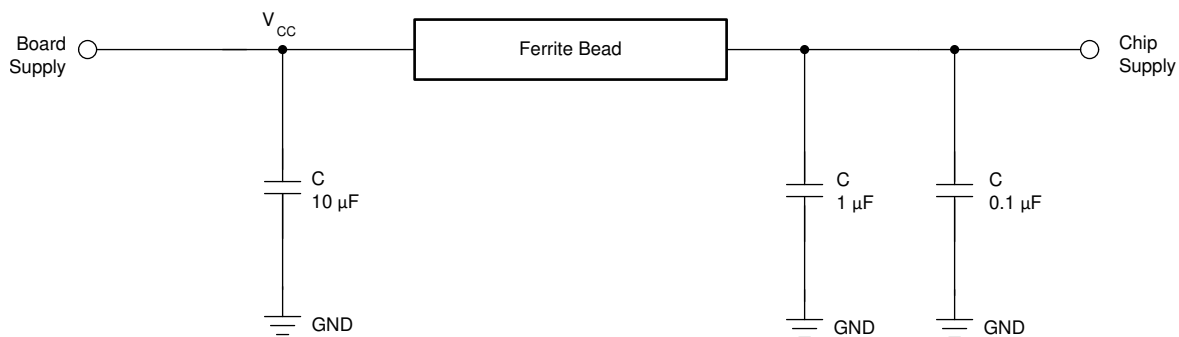

Figure 10-1. Power Supply Decoupling

11 Layout

11.1 Layout Guidelines

图 11-1 shows a conceptual layout detailing recommended placement of power supply bypass capacitors. For component side mounting, use 0402 body size capacitors to facilitate signal routing. Keep the connections between the bypass capacitors and the power supply on the device as short as possible. Ground the other side of the capacitor using a low-impedance connection to the ground plane.

11.2 Layout Example



图 11-1. PCB Conceptual Layout

12 Device and Documentation Support

12.1 Documentation Support

12.1.1 Related Documentation

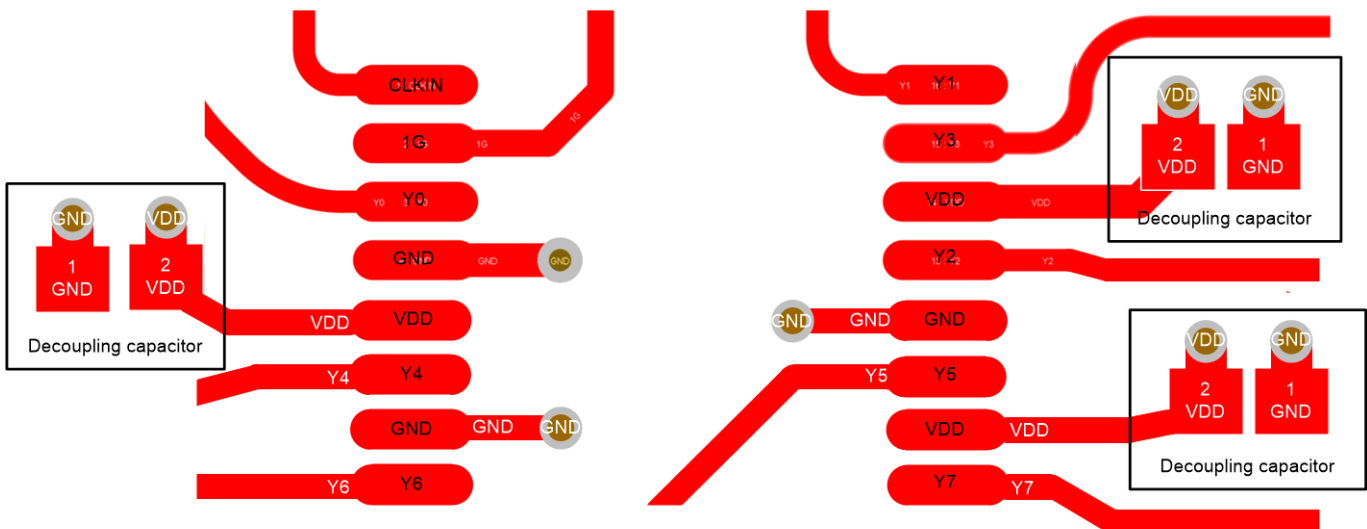
For related documentation, see the following:

[LMK1C1108EVM User Guide](#)

12.2 接收文档更新通知

要接收文档更新通知，请导航至 [ti.com](#) 上的器件产品文件夹。点击 [订阅更新](#) 进行注册，即可每周接收产品信息更改摘要。有关更改的详细信息，请查看任何已修订文档中包含的修订历史记录。

12.3 支持资源

[TI E2E™ 支持论坛](#) 是工程师的重要参考资料，可直接从专家获得快速、经过验证的解答和设计帮助。搜索现有解答或提出自己的问题可获得所需的快速设计帮助。

链接的内容由各个贡献者“按原样”提供。这些内容并不构成 TI 技术规范，并且不一定反映 TI 的观点；请参阅 TI 的《[使用条款](#)》。

12.4 Trademarks

TI E2E™ is a trademark of Texas Instruments.

所有商标均为其各自所有者的财产。

12.5 Electrostatic Discharge Caution



This integrated circuit can be damaged by ESD. Texas Instruments recommends that all integrated circuits be handled with appropriate precautions. Failure to observe proper handling and installation procedures can cause damage.

ESD damage can range from subtle performance degradation to complete device failure. Precision integrated circuits may be more susceptible to damage because very small parametric changes could cause the device not to meet its published specifications.

12.6 术语表

[TI 术语表](#) 本术语表列出并解释了术语、首字母缩略词和定义。

13 Mechanical, Packaging, and Orderable Information

The following pages include mechanical, packaging, and orderable information. This information is the most current data available for the designated devices. This data is subject to change without notice and revision of this document. For browser-based versions of this data sheet, refer to the left-hand navigation.

PACKAGING INFORMATION

Orderable part number	Status (1)	Material type (2)	Package Pins	Package qty Carrier	RoHS (3)	Lead finish/ Ball material (4)	MSL rating/ Peak reflow (5)	Op temp (°C)	Part marking (6)
LMK1C1106PWR	Active	Production	TSSOP (PW) 14	3000 LARGE T&R	Yes	NIPDAU SN	Level-1-260C-UNLIM	-40 to 125	LMK1C6
LMK1C1106PWR.A	Active	Production	TSSOP (PW) 14	3000 LARGE T&R	Yes	NIPDAU	Level-1-260C-UNLIM	-40 to 125	LMK1C6
LMK1C1108PWR	Active	Production	TSSOP (PW) 16	3000 LARGE T&R	Yes	NIPDAU SN	Level-1-260C-UNLIM	-40 to 125	LMK1C8
LMK1C1108PWR.A	Active	Production	TSSOP (PW) 16	3000 LARGE T&R	Yes	NIPDAU	Level-1-260C-UNLIM	-40 to 125	LMK1C8
LMK1C1108PWRG4	Active	Production	TSSOP (PW) 16	3000 LARGE T&R	Yes	NIPDAU	Level-1-260C-UNLIM	-40 to 125	LMK1C8
LMK1C1108PWRG4.A	Active	Production	TSSOP (PW) 16	3000 LARGE T&R	Yes	NIPDAU	Level-1-260C-UNLIM	-40 to 125	LMK1C8

⁽¹⁾ **Status:** For more details on status, see our [product life cycle](#).

⁽²⁾ **Material type:** When designated, preproduction parts are prototypes/experimental devices, and are not yet approved or released for full production. Testing and final process, including without limitation quality assurance, reliability performance testing, and/or process qualification, may not yet be complete, and this item is subject to further changes or possible discontinuation. If available for ordering, purchases will be subject to an additional waiver at checkout, and are intended for early internal evaluation purposes only. These items are sold without warranties of any kind.

⁽³⁾ **RoHS values:** Yes, No, RoHS Exempt. See the [TI RoHS Statement](#) for additional information and value definition.

⁽⁴⁾ **Lead finish/Ball material:** Parts may have multiple material finish options. Finish options are separated by a vertical ruled line. Lead finish/Ball material values may wrap to two lines if the finish value exceeds the maximum column width.

⁽⁵⁾ **MSL rating/Peak reflow:** The moisture sensitivity level ratings and peak solder (reflow) temperatures. In the event that a part has multiple moisture sensitivity ratings, only the lowest level per JEDEC standards is shown. Refer to the shipping label for the actual reflow temperature that will be used to mount the part to the printed circuit board.

⁽⁶⁾ **Part marking:** There may be an additional marking, which relates to the logo, the lot trace code information, or the environmental category of the part.

Multiple part markings will be inside parentheses. Only one part marking contained in parentheses and separated by a "~" will appear on a part. If a line is indented then it is a continuation of the previous line and the two combined represent the entire part marking for that device.

Important Information and Disclaimer: The information provided on this page represents TI's knowledge and belief as of the date that it is provided. TI bases its knowledge and belief on information provided by third parties, and makes no representation or warranty as to the accuracy of such information. Efforts are underway to better integrate information from third parties. TI has taken and continues to take reasonable steps to provide representative and accurate information but may not have conducted destructive testing or chemical analysis on incoming materials and chemicals. TI and TI suppliers consider certain information to be proprietary, and thus CAS numbers and other limited information may not be available for release.

In no event shall TI's liability arising out of such information exceed the total purchase price of the TI part(s) at issue in this document sold by TI to Customer on an annual basis.

TAPE AND REEL INFORMATION

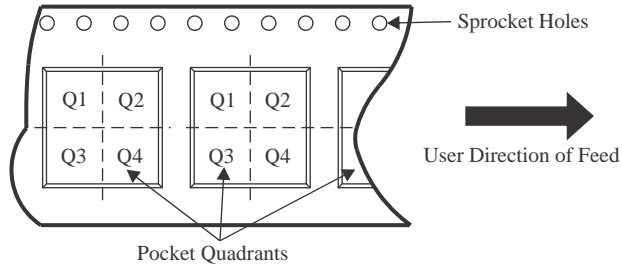
QUADRANT ASSIGNMENTS FOR PIN 1 ORIENTATION IN TAPE

*All dimensions are nominal

Device	Package Type	Package Drawing	Pins	SPQ	Reel Diameter (mm)	Reel Width W1 (mm)	A0 (mm)	B0 (mm)	K0 (mm)	P1 (mm)	W (mm)	Pin1 Quadrant
LMK1C1106PWR	TSSOP	PW	14	3000	330.0	12.4	6.9	5.6	1.6	8.0	12.0	Q1
LMK1C1108PWR	TSSOP	PW	16	3000	330.0	12.4	6.9	5.6	1.6	8.0	12.0	Q1
LMK1C1108PWR	TSSOP	PW	16	3000	330.0	12.4	6.9	5.6	1.6	8.0	12.0	Q1
LMK1C1108PWRG4	TSSOP	PW	16	3000	330.0	12.4	6.9	5.6	1.6	8.0	12.0	Q1

TAPE AND REEL BOX DIMENSIONS



*All dimensions are nominal

Device	Package Type	Package Drawing	Pins	SPQ	Length (mm)	Width (mm)	Height (mm)
LMK1C1106PWR	TSSOP	PW	14	3000	356.0	356.0	35.0
LMK1C1108PWR	TSSOP	PW	16	3000	356.0	356.0	35.0
LMK1C1108PWR	TSSOP	PW	16	3000	353.0	353.0	32.0
LMK1C1108PWRG4	TSSOP	PW	16	3000	353.0	353.0	32.0



4220204/B 12/2023

NOTES:

1. All linear dimensions are in millimeters. Any dimensions in parenthesis are for reference only. Dimensioning and tolerancing per ASME Y14.5M.
2. This drawing is subject to change without notice.
3. This dimension does not include mold flash, protrusions, or gate burrs. Mold flash, protrusions, or gate burrs shall not exceed 0.15 mm per side.
4. This dimension does not include interlead flash. Interlead flash shall not exceed 0.25 mm per side.
5. Reference JEDEC registration MO-153.

EXAMPLE BOARD LAYOUT

PW0016A

TSSOP - 1.2 mm max height

SMALL OUTLINE PACKAGE



LAND PATTERN EXAMPLE
EXPOSED METAL SHOWN
SCALE: 10X



SOLDER MASK DETAILS

4220204/B 12/2023

NOTES: (continued)

- 6. Publication IPC-7351 may have alternate designs.
- 7. Solder mask tolerances between and around signal pads can vary based on board fabrication site.

EXAMPLE STENCIL DESIGN

PW0016A

TSSOP - 1.2 mm max height

SMALL OUTLINE PACKAGE



SOLDER PASTE EXAMPLE
BASED ON 0.125 mm THICK STENCIL
SCALE: 10X

4220204/B 12/2023

NOTES: (continued)

8. Laser cutting apertures with trapezoidal walls and rounded corners may offer better paste release. IPC-7525 may have alternate design recommendations.
9. Board assembly site may have different recommendations for stencil design.

PW0014A

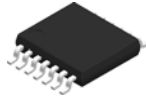

PACKAGE OUTLINE

TSSOP - 1.2 mm max height

SMALL OUTLINE PACKAGE



4220202/B 12/2023

NOTES:

- All linear dimensions are in millimeters. Any dimensions in parenthesis are for reference only. Dimensioning and tolerancing per ASME Y14.5M.
- This drawing is subject to change without notice.
- This dimension does not include mold flash, protrusions, or gate burrs. Mold flash, protrusions, or gate burrs shall not exceed 0.15 mm per side.
- This dimension does not include interlead flash. Interlead flash shall not exceed 0.25 mm per side.
- Reference JEDEC registration MO-153.

EXAMPLE BOARD LAYOUT

PW0014A

TSSOP - 1.2 mm max height

SMALL OUTLINE PACKAGE



LAND PATTERN EXAMPLE
EXPOSED METAL SHOWN
SCALE: 10X



4220202/B 12/2023

NOTES: (continued)

- 6. Publication IPC-7351 may have alternate designs.
- 7. Solder mask tolerances between and around signal pads can vary based on board fabrication site.

EXAMPLE STENCIL DESIGN

PW0014A

TSSOP - 1.2 mm max height

SMALL OUTLINE PACKAGE



SOLDER PASTE EXAMPLE
BASED ON 0.125 mm THICK STENCIL
SCALE: 10X

4220202/B 12/2023

NOTES: (continued)

8. Laser cutting apertures with trapezoidal walls and rounded corners may offer better paste release. IPC-7525 may have alternate design recommendations.
9. Board assembly site may have different recommendations for stencil design.

重要通知和免责声明

TI“按原样”提供技术和可靠性数据（包括数据表）、设计资源（包括参考设计）、应用或其他设计建议、网络工具、安全信息和其他资源，不保证没有瑕疵且不做任何明示或暗示的担保，包括但不限于对适销性、与某特定用途的适用性或不侵犯任何第三方知识产权的暗示担保。

这些资源可供使用 TI 产品进行设计的熟练开发人员使用。您将自行承担以下全部责任：(1) 针对您的应用选择合适的 TI 产品，(2) 设计、验证并测试您的应用，(3) 确保您的应用满足相应标准以及任何其他安全、安保法规或其他要求。

这些资源如有变更，恕不另行通知。TI 授权您仅可将这些资源用于研发本资源所述的 TI 产品的相关应用。严禁以其他方式对这些资源进行复制或展示。您无权使用任何其他 TI 知识产权或任何第三方知识产权。对于因您对这些资源的使用而对 TI 及其代表造成的任何索赔、损害、成本、损失和债务，您将全额赔偿，TI 对此概不负责。

TI 提供的产品受 [TI 销售条款](#)、[TI 通用质量指南](#) 或 [ti.com](#) 上其他适用条款或 TI 产品随附的其他适用条款的约束。TI 提供这些资源并不会扩展或以其他方式更改 TI 针对 TI 产品发布的适用的担保或担保免责声明。除非德州仪器 (TI) 明确将某产品指定为定制产品或客户特定产品，否则其产品均为按确定价格收入目录的标准通用器件。

TI 反对并拒绝您可能提出的任何其他或不同的条款。

版权所有 © 2026，德州仪器 (TI) 公司

最后更新日期：2025 年 10 月