

采用 DSBGA 封装的 LMR24210 42V 输入电压、1A 降压稳压器

1 特性

- 输入电压范围为 4.5V 至 42V
- 输出电压范围为 0.8V 至 24V
- 输出电流高达 1A
- 集成 $R_{DS(ON)}$ 同步 MOSFET，具有高效率
- 高达 1MHz 的开关频率
- 低关断 I_Q ，典型值为 25 μ A
- 可编程软启动
- 无需环路补偿
- 具有 ERM 架构的 COT
- 微型整体解决方案降低了系统成本
- 集成同步 MOSFET 可在低输出电压下提供高效率
- 与低 ESR 电容器一起工作时保持稳定
- 28 凸点 DSBGA 封装
- 使用 LMR24010 并借助 WEBENCH® 电源设计器创建定制设计方案

2 应用

- 从 5V、12V 和 24V 电源轨到负载点的转换
- 空间受限型 应用
- 工业分布式电源 应用
- 功率计

3 说明

LMR24210 同步整流降压转换器 具有 实现低成本高效率的降压稳压器所需的全部功能。该器件能够为负载提供 1A 的电流及低至 0.8V 的输出电压。双 N 沟道同步 MOSFET 开关允许使用少量组件，从而降低复杂性，并最大限度减小电路板尺寸。

不同于大多数其他 COT 稳压器，LMR24210 不依赖于输出电容器 ESR 来获得稳定性，并且其专为与陶瓷及其他 ESR 极低的输出电容器完美配合工作而设计。它无需环路补偿，从而实现快速负载瞬态响应，并简化电路实现。由于输入电压和导通时间之间呈反比关系，因此在线路发生变化时，器件的工作频率几乎保持恒定。通过外部编程，工作频率可高达 1MHz。保护功能包括 V_{CC} 欠压锁定、输出过压保护、热关断和栅极驱动欠压锁定。LMR24210 采用小型 DSBGA 薄型芯片级封装。

器件信息(1)

器件型号	封装	封装尺寸 (最大值)
LMR24010	DSBGA (28)	3.676mm × 2.48mm

(1) 如需了解所有可用封装，请参阅产品说明书末尾的可订购产品附录。

典型应用

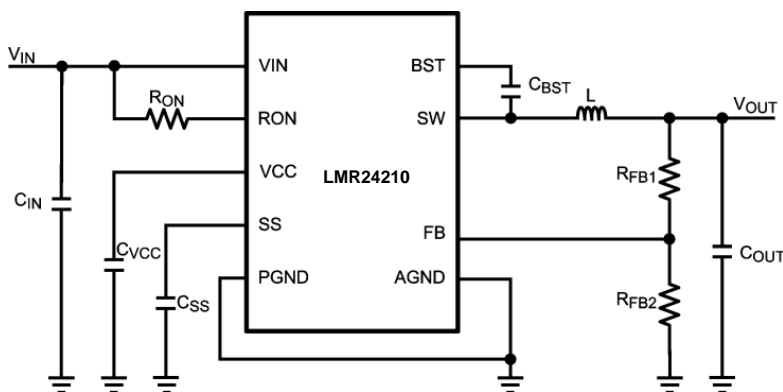

目录

1	特性	1	7.3	Feature Description.....	10
2	应用	1	8	Application and Implementation	14
3	说明	1	8.1	Application Information.....	14
4	修订历史记录	2	8.2	Typical Application	14
5	Pin Configuration and Functions	3	9	Layout	18
6	Specifications	4	9.1	Layout Considerations	18
6.1	Absolute Maximum Ratings	4	9.2	Layout Examples.....	18
6.2	ESD Ratings.....	4	9.3	Package Considerations	19
6.3	Recommended Operating Ratings	4	10	器件和文档支持	20
6.4	Electrical Characteristics.....	5	10.1	器件支持	20
6.5	Typical Characteristics	6	10.2	接收文档更新通知	20
7	Detailed Description	9	10.3	社区资源	20
7.1	Overview	9	10.4	商标	20
7.2	Functional Block Diagram	9	10.5	静电放电警告	20
			10.6	Glossary	20

4 修订历史记录

注：之前版本的页码可能与当前版本有所不同。

Changes from Revision G (April 2013) to Revision H Page

- 仅有编辑更改；添加了 WEBENCH 链接

1

Changes from Revision E (April 2013) to Revision F Page

- 已更改 将美国国家半导体数据表的布局更改为 TI 格式

1

5 Pin Configuration and Functions

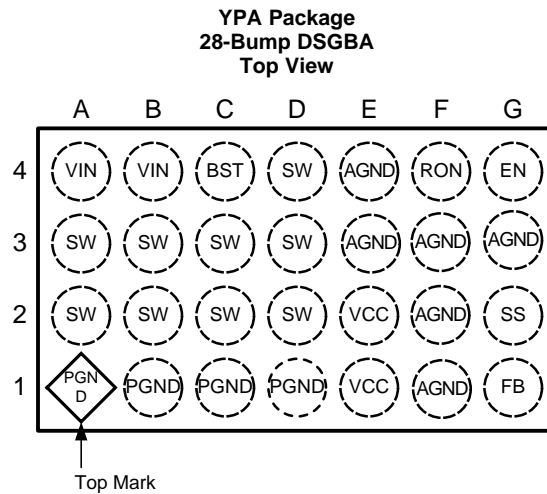

Pin Descriptions

PIN		DESCRIPTION	
NO.	NAME		
A2, A3, B2, B3, C2, C3, D2, D3, D4	SW	Switching node	Internally connected to the source of the main MOSFET and the drain of the Synchronous MOSFET. Connect to the inductor.
A4, B4	VIN	Input supply voltage	Supply pin to the device. Nominal input range is 4.5 V to 42 V.
C4	BST	Connection for bootstrap capacitor	Connect a 33-nF capacitor from the SW pin to this pin. An internal diode charges the capacitor during the main MOSFET off-time.
E3, E4, F1, F2, F3, G3	AGND	Analog ground	Ground for all internal circuitry other than the PGND pin.
G2	SS	Soft start	An 8- μ A internal current source charges an external capacitor to provide the soft-start function.
G1	FB	Feedback	Internally connected to the regulation and over-voltage comparators. The regulation setting is 0.8V at this pin. Connect to feedback resistors.
G4	EN	Enable	Connect a voltage higher than 1.26V to enable the regulator. Leaving this input open circuit enables the device at internal UVLO level.
F4	RON	On-time control	An external resistor from the VIN pin to this pin sets the main MOSFET on-time.
E1, E2	VCC	Start-up regulator output	Nominally regulated to 6 V. Connect a capacitor of not less than 680 nF between the VCC and AGND pins for stable operation.
A1, B1, C1, D1	PGND	Power ground	Synchronous MOSFET source connection. Tie to a ground plane.

6 Specifications

6.1 Absolute Maximum Ratings

 See notes⁽¹⁾⁽²⁾

VIN, RON to AGND	-0.3V to 43.5V
SW to AGND	-0.3V to 43.5V
SW to AGND (Transient)	-2V (< 100ns)
VIN to SW	-0.3V to 43.5V
BST to SW	-0.3V to 7V
All Other Inputs to AGND	-0.3V to 7V
Storage Temperature Range	-65°C to +150°C
Junction Temperature (T _J)	150°C

- (1) Absolute Maximum Ratings are limits beyond which damage to the device may occur. Operating Ratings are conditions under which operation of the device is intended to be functional. For ensured specifications and test conditions, see [Electrical Characteristics](#).
- (2) If Military/Aerospace specified devices are required, contact the Texas Instruments Sales Office/ Distributors for availability and specifications.

6.2 ESD Ratings

			VALUE	UNIT
V _(ESD)	Electrostatic discharge	Human-body model (HBM), per ANSI/ESDA/JEDEC JS-001 ⁽¹⁾	±2000	V

- (1) JEDEC document JEP155 states that 500-V HBM allows safe manufacturing with a standard ESD control process.

6.3 Recommended Operating Ratings

 See note⁽¹⁾

Supply Voltage Range (VIN)	4.5V to 42V
Junction Temperature Range (T _J)	-40°C to +125°C
Thermal Resistance (θ _{JA}) 28-ball DSBGA ⁽²⁾	50°C/W
For soldering specifications see SNOA549	

- (1) Absolute Maximum Ratings are limits beyond which damage to the device may occur. Operating Ratings are conditions under which operation of the device is intended to be functional. For ensured specifications and test conditions, see [Electrical Characteristics](#).
- (2) θ_{JA} calculations were performed in general accordance with JEDEC standards JESD51-1 to JESD51-11.

6.4 Electrical Characteristics

Specifications with standard type are for $T_J = 25^\circ\text{C}$ only; limits in **boldface type** apply over the full operating junction temperature (T_J) range. Minimum and Maximum limits are ensured through test, design, or statistical correlation. Typical values represent the most likely parametric norm at $T_J = 25^\circ\text{C}$, and are provided for reference purposes only. Unless otherwise stated the following conditions apply: $V_{IN} = 18\text{V}$, $V_{OUT} = 3.3\text{V}$.⁽¹⁾

PARAMETER		TEST CONDITIONS	MIN	TYP	MAX	UNIT
START-UP REGULATOR, V_{CC}						
V_{CC}	V_{CC} output voltage	$C_{CC} = 680\text{nF}$, no load	5.0	6.0	7.2	V
$V_{IN} - V_{CC}$	$V_{IN} - V_{CC}$ dropout voltage	$I_{CC} = 20\text{mA}$		350		mV
I_{VCC}	V_{CC} current limit ⁽²⁾	$V_{CC} = 0\text{V}$	40	65		mA
$V_{CC-UVLO}$	V_{CC} under-voltage lockout threshold (UVLO)	V_{IN} increasing	3.55	3.75	3.95	V
$V_{CC-UVLO-HYS}$	V_{CC} UVLO hysteresis	V_{IN} decreasing – DSBGA package		150		mV
$t_{VCC-UVLO-D}$	V_{CC} UVLO filter delay			3		μs
I_{IN}	I_{IN} operating current	No switching, $V_{FB} = 1\text{V}$		0.7	1	mA
I_{IN-SD}	I_{IN} operating current, Device shutdown	$V_{EN} = 0\text{V}$		25	40	μA
SWITCHING CHARACTERISTICS						
$R_{DS-UP-ON}$	Main MOSFET $R_{DS(on)}$			0.18	0.375	Ω
$R_{DS-DN-ON}$	Syn. MOSFET $R_{DS(on)}$			0.11	0.225	Ω
V_{G-UVLO}	Gate drive voltage UVLO	$V_{BST} - V_{SW}$ increasing		3.3	4	V
SOFT START						
I_{SS}	SS pin source current	$V_{SS} = 0.5\text{V}$		11		μA
CURRENT LIMIT						
I_{CL}	Syn. MOSFET current limit threshold	LMR24210	1.2	1.8	2.6	A
ON/OFF TIMER						
t_{on}	ON timer pulse width	$V_{IN} = 10\text{V}$, $R_{ON} = 100\text{k}\Omega$		1.38		μs
		$V_{IN} = 30\text{V}$, $R_{ON} = 100\text{k}\Omega$		0.47		
t_{on-MIN}	ON timer minimum pulse width			150		ns
t_{off}	OFF timer pulse width			260		ns
ENABLE INPUT						
V_{EN}	EN Pin input threshold	V_{EN} rising	1.13	1.18	1.23	V
V_{EN-HYS}	Enable threshold hysteresis	V_{EN} falling		90		mV
REGULATION AND OVERVOLTAGE COMPARATOR						
V_{FB}	In-regulation feedback voltage	$V_{SS} \geq 0.8\text{V}$ $T_J = -40^\circ\text{C}$ to $+125^\circ\text{C}$	0.784	0.8	0.816	V
V_{FB-OV}	Feedback overvoltage threshold		0.888	0.920	0.945	V
I_{FB}	FB pin current			5		nA
THERMAL SHUTDOWN						
T_{SD}	Thermal shutdown temperature	T_J rising		165		$^\circ\text{C}$
T_{SD-HYS}	Thermal shutdown temperature hysteresis	T_J falling		20		$^\circ\text{C}$

- (1) Min and Max limits are 100% production tested at 25°C . Limits over the operating temperature range are ensured through correlation using Statistical Quality Control (SQC) methods. Limits are used to calculate Average Outgoing Quality Level (AOQL).
- (2) V_{CC} provides self bias for the internal gate drive and control circuits. Device thermal limitations limit external loading.

6.5 Typical Characteristics

Unless otherwise specified all curves are taken at $V_{IN} = 18\text{ V}$ with the configuration in the typical application circuit for $V_{OUT} = 3.3\text{ V}$ (Figure 26) $T_A = 25^\circ\text{C}$.

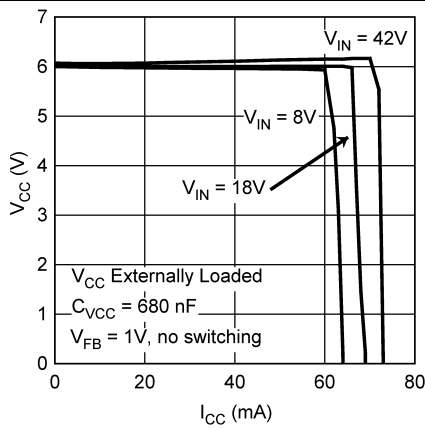

Figure 1. V_{CC} vs I_{CC}

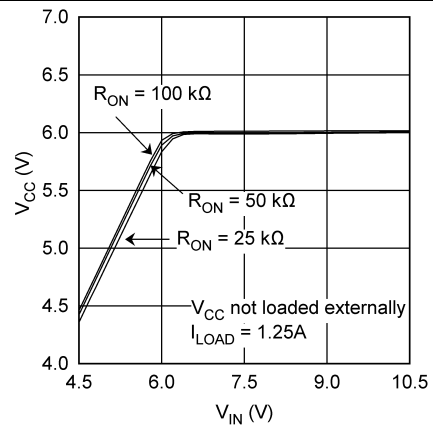

Figure 2. V_{CC} vs V_{IN}

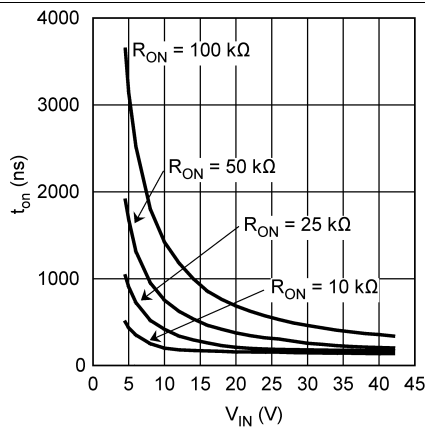

Figure 3. T_{on} vs V_{IN}

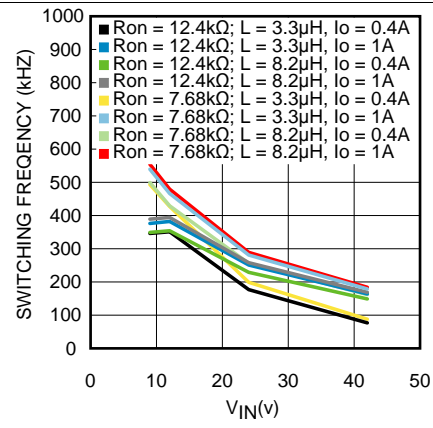

Figure 4. Switching Frequency, F_{SW} vs V_{IN} , $V_{OUT}=0.8\text{V}$,

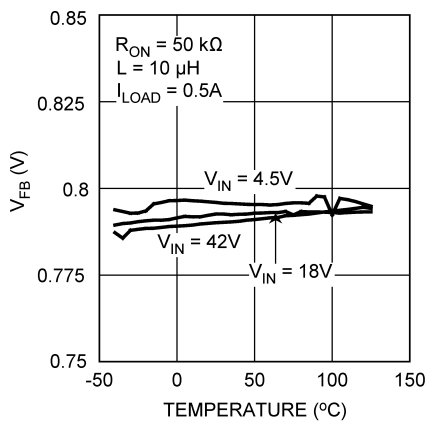

Figure 5. V_{FB} vs Temperature

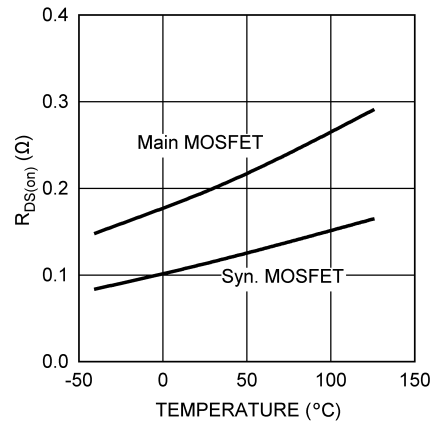

Figure 6. $R_{DS(on)}$ vs Temperature

Typical Characteristics (continued)

Unless otherwise specified all curves are taken at $V_{IN} = 18\text{ V}$ with the configuration in the typical application circuit for $V_{OUT} = 3.3\text{ V}$ (Figure 26) $T_A = 25^\circ\text{C}$.

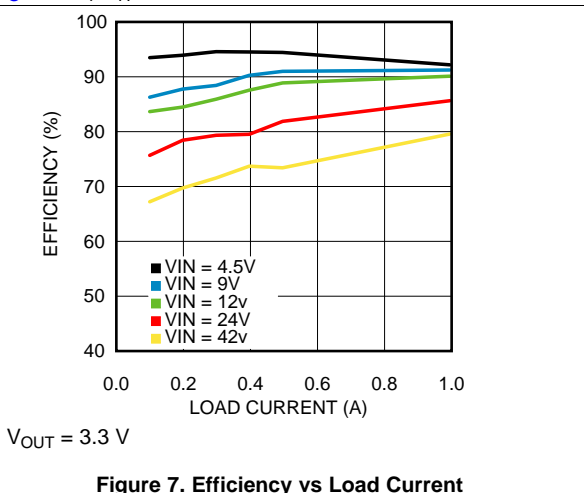

Figure 7. Efficiency vs Load Current

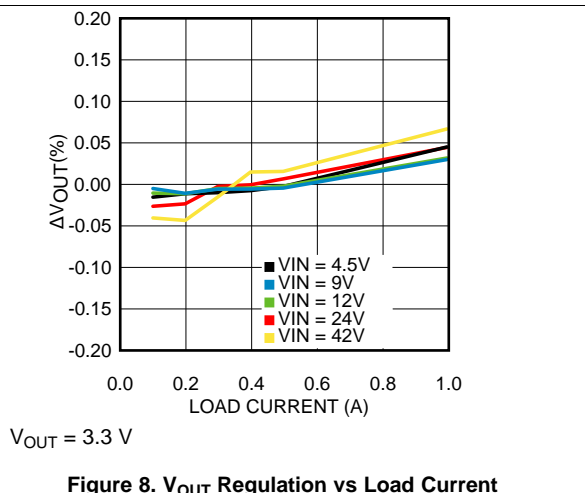

Figure 8. V_{OUT} Regulation vs Load Current

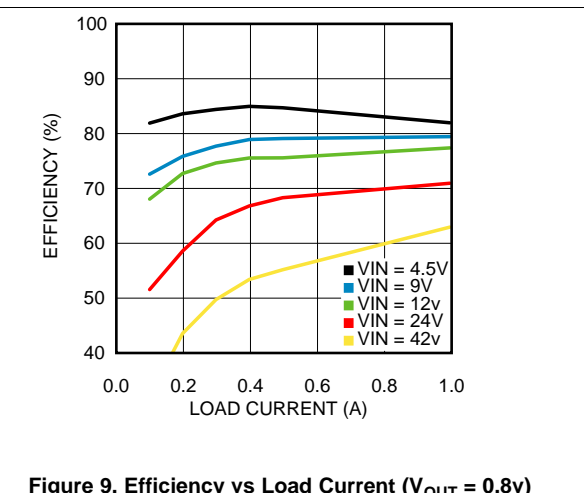

Figure 9. Efficiency vs Load Current ($V_{OUT} = 0.8\text{ v}$)

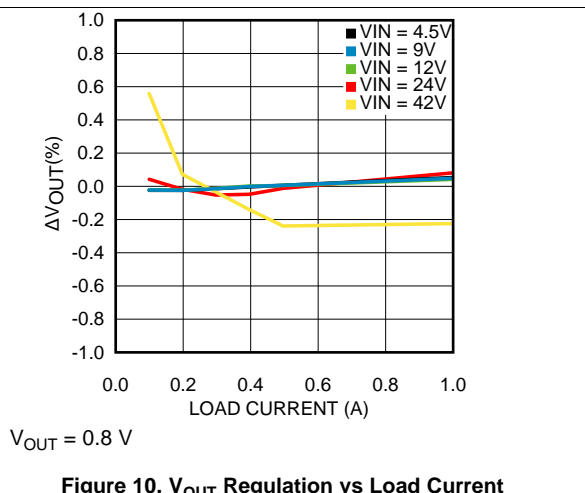

Figure 10. V_{OUT} Regulation vs Load Current

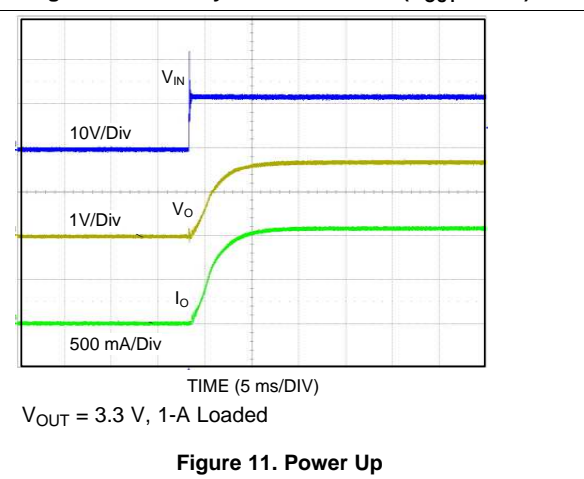

Figure 11. Power Up

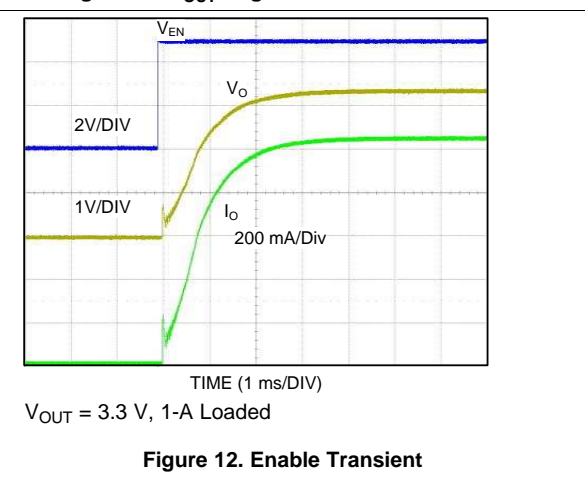
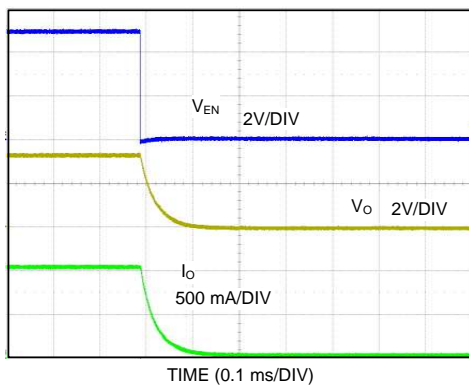

Figure 12. Enable Transient

Typical Characteristics (continued)

Unless otherwise specified all curves are taken at $V_{IN} = 18\text{ V}$ with the configuration in the typical application circuit for $V_{OUT} = 3.3\text{ V}$ (Figure 26) $T_A = 25^\circ\text{C}$.



$V_{OUT} = 3.3\text{ V}, 1\text{ A Loaded}$

Figure 13. Shutdown Transient

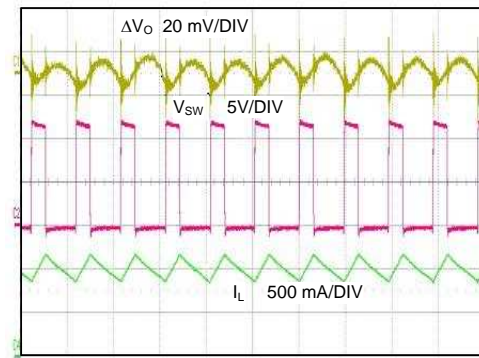

$V_{OUT} = 3.3\text{ V}, 1\text{ A Loaded}$

Figure 14. Continuous Mode Operation

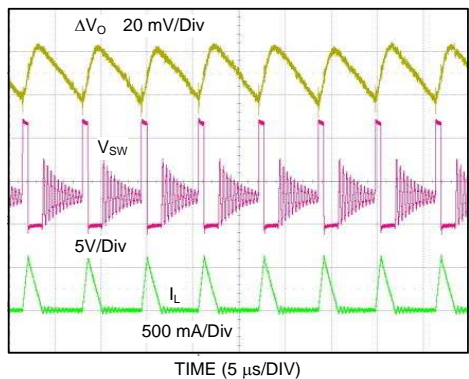

$V_{OUT} = 3.3\text{ V}, 0.5\text{ A Loaded}$

Figure 15. Discontinuous Mode Operation

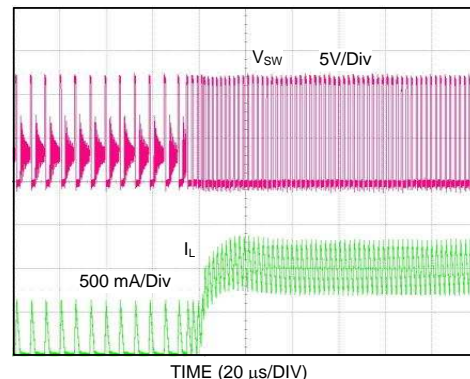

$V_{OUT} = 3.3\text{ V}, 0.5\text{ A to }1\text{ A Load}$

Figure 16. DCM to CCM Transition

7 Detailed Description

7.1 Overview

The LMR24210 step-down switching regulator features all required functions to implement a cost effective, efficient buck power converter capable of supplying 1 A to a load. It contains dual N-channel main and synchronous MOSFETs. The constant on-time (COT) regulation scheme requires no loop compensation, results in fast load transient response and simple circuit implementation. The regulator can function properly even with an all ceramic output capacitor network, and does not rely on the output capacitor's ESR for stability. The operating frequency remains constant with line variations due to the inverse relationship between the input voltage and the on-time. The valley current limit detection circuit, with the limit set internally at 1.8 A, inhibits the main MOSFET until the inductor current level subsides.

The LMR24210 can be applied in numerous applications and can operate efficiently for inputs as high as 42 V. Protection features include output overvoltage protection, thermal shutdown, V_{CC} undervoltage lockout and gate-drive undervoltage lockout. The LMR24210 is available in a small DSBGA chip-scale package.

7.2 Functional Block Diagram

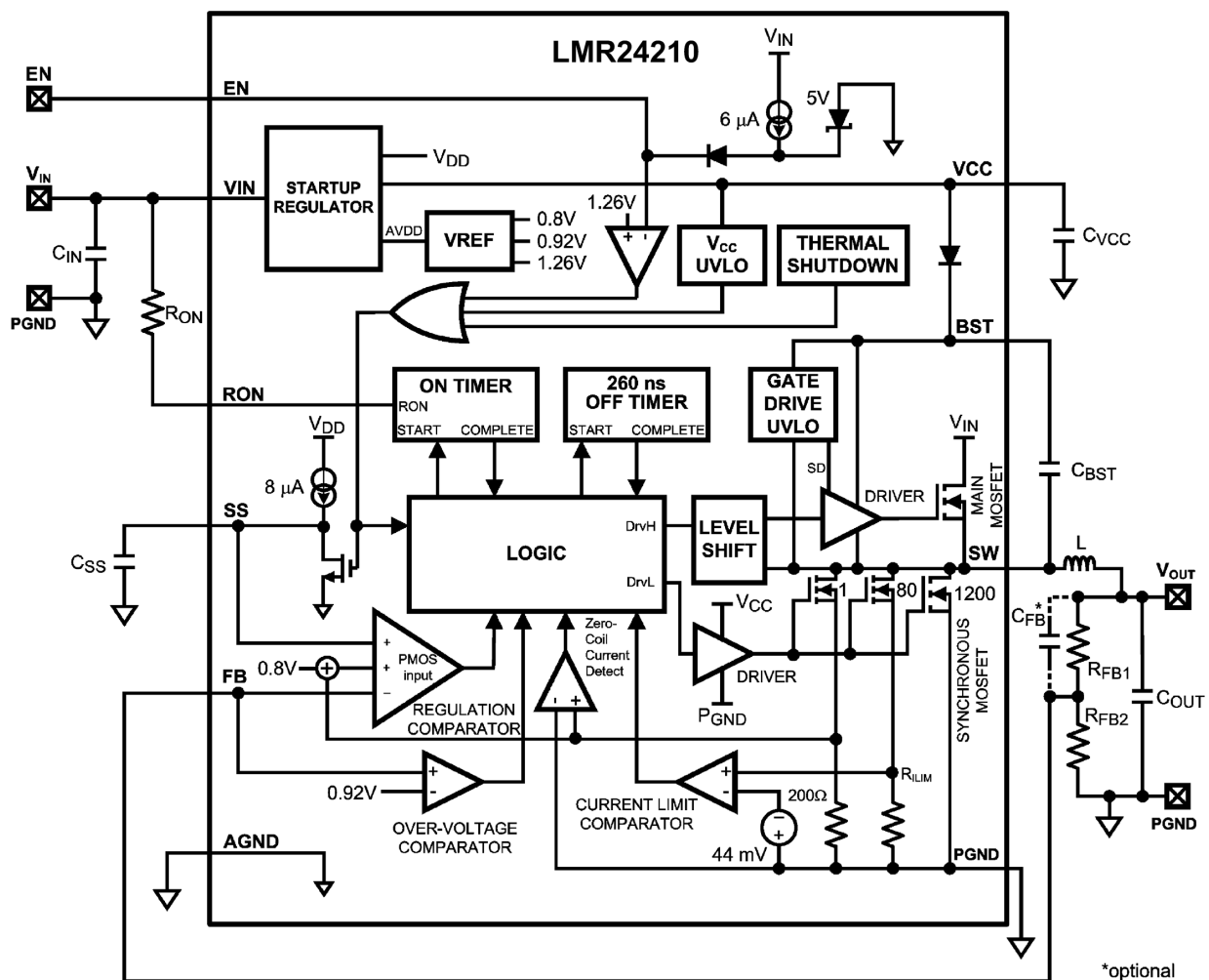

7.3 Feature Description

7.3.1 COT Control Circuit Overview

COT control is based on a comparator and a one-shot on-timer, with the output voltage feedback (feeding to the FB pin) compared with an internal reference of 0.8 V. If the voltage of the FB pin is below the reference, the main MOSFET is turned on for a fixed on-time determined by a programming resistor R_{ON} and the input voltage V_{IN} , upon which the on-time varies inversely. Following the on-time, the main MOSFET remains off for a minimum of 260 ns. Then, if the voltage of the FB pin is below the reference, the main MOSFET is turned on again for another on-time period. The switching will continue to achieve regulation.

The regulator will operate in the discontinuous conduction mode (DCM) at a light load, and the continuous conduction mode (CCM) with a heavy load. In the DCM, the current through the inductor starts at zero and ramps up to a peak during the on-time, and then ramps back to zero before the end of the off-time. It remains zero and the load current is supplied entirely by the output capacitor. The next on-time period starts when the voltage at the FB pin falls below the internal reference. The operating frequency in the DCM is lower and varies larger with the load current as compared with the CCM. Conversion efficiency is maintained since conduction loss and switching loss are reduced with the reduction in the load and the switching frequency respectively. The operating frequency in the DCM can be calculated approximately as follows:

$$f_{SW} = \frac{V_{OUT} (V_{IN} - 1) \times L \times 1.18 \times 10^{20} \times I_{OUT}}{(V_{IN} - V_{OUT}) \times R_{ON}^2} \quad (1)$$

In the CCM, the current flows through the inductor in the entire switching cycle, and never reaches zero during the off-time. The operating frequency remains relatively constant with load and line variations. The CCM operating frequency can be calculated approximately as follows:

$$f_{SW} = \frac{V_{OUT}}{1.3 \times 10^{-10} \times R_{ON}} \quad (2)$$

Consider and [Equation 5](#) when choosing the switching frequency.

The output voltage is set by two external resistors R_{FB1} and R_{FB2} . The regulated output voltage is

$$V_{OUT} = 0.8 \text{ V} \times (R_{FB1} + R_{FB2}) / R_{FB2} \quad (3)$$

7.3.2 Start-up Regulator (V_{CC})

A start-up regulator is integrated within the LMR24210. The input pin V_{IN} can be connected directly to a line voltage up to 42 V. The V_{CC} output regulates at 6 V, and is current limited to 65 mA. Upon power up, the regulator sources current into an external capacitor C_{VCC} , which is connected to the V_{CC} pin. For stability, C_{VCC} must be at least 680 nF. When the voltage on the V_{CC} pin is higher than the undervoltage lockout (UVLO) threshold of 3.75 V, the main MOSFET is enabled and the SS pin is released to allow the soft-start capacitor C_{SS} to charge.

The minimum input voltage is determined by the dropout voltage of the regulator and the V_{CC} UVLO falling threshold (≈ 3.7 V). If V_{IN} is less than ≈ 4 V, the regulator shuts off and V_{CC} goes to zero.

7.3.3 Regulation Comparator

The feedback voltage at the FB pin is compared to a 0.8-V internal reference. In normal operation (the output voltage is regulated), an on-time period is initiated when the voltage at the FB pin falls below 0.8 V. The main MOSFET stays on for the on-time, causing the output voltage and consequently the voltage of the FB pin to rise above 0.8 V. After the on-time period, the main MOSFET stays off until the voltage of the FB pin falls below 0.8V again. Bias current at the FB pin is nominally 5 nA.

7.3.4 Zero Coil Current Detect

The current of the synchronous MOSFET is monitored by a zero coil current detection circuit which inhibits the synchronous MOSFET when its current reaches zero until the next on-time. This circuit enables the DCM operation, which improves the efficiency at a light load.

Feature Description (continued)

7.3.5 Overvoltage Comparator

The voltage at the FB pin is compared to a 0.92-V internal reference. If it rises above 0.92 V, the on-time is immediately terminated. This condition is known as overvoltage protection (OVP). It can occur if the input voltage or the output load changes suddenly. Once the OVP is activated, the main MOSFET remains off until the voltage at the FB pin falls below 0.92 V. The synchronous MOSFET stays on to discharge the inductor until the inductor current reduces to zero, and then switches off.

7.3.6 On-Time Timer, Shutdown

The on-time of the LMR24210 main MOSFET is determined by the resistor R_{ON} and the input voltage V_{IN} . It is calculated as follows:

$$t_{on} = \frac{1.3 \times 10^{-10} \times R_{ON}}{V_{IN}} \quad (4)$$

The inverse relationship of t_{on} and V_{IN} gives a nearly constant frequency as V_{IN} is varied. R_{ON} should be selected such that the on-time at maximum V_{IN} is greater than 150 ns. The on-timer has a limiter to ensure a minimum of 150 ns for t_{on} . This limits the maximum operating frequency, which is governed by the following equation:

$$f_{SW(MAX)} = \frac{V_{OUT}}{V_{IN(MAX)} \times 150 \text{ ns}} \quad (5)$$

The LMR24210 can be remotely shutdown by pulling the voltage of the EN pin below 1 V. In this shutdown mode, the SS pin is internally grounded, the on-timer is disabled, and bias currents are reduced. Releasing the EN pin allows normal operation to resume because the EN pin is internally pulled up.

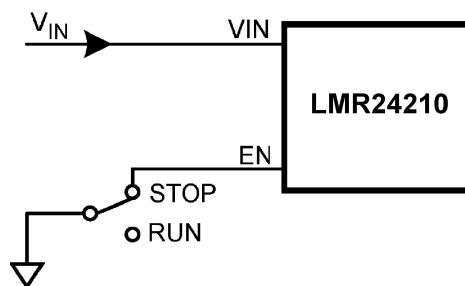

Figure 17. Shutdown Implementation

7.3.7 Current Limit

Current limit detection is carried out during the off-time by monitoring the re-circulating current through the synchronous MOSFET. Referring to the *Functional Block Diagram*, when the main MOSFET is turned off, the inductor current flows through the load, the PGND pin and the internal synchronous MOSFET. If this current exceeds 1.8 A, the current limit comparator toggles, and as a result disabling the start of the next on-time period. The next switching cycle starts when the re-circulating current falls back below 1.8 A (and the voltage at the FB pin is below 0.8 V). The inductor current is monitored during the on-time of the synchronous MOSFET. As long as the inductor current exceeds 1.8 A, the main MOSFET remains inhibited to achieve current limit. The operating frequency is lower during current limit due to a longer off-time.

Figure 18 illustrates an inductor current waveform. On average, the output current I_{OUT} is the same as the inductor current I_L , which is the average of the rippled inductor current. In case of current limit (the current limit portion of Figure 18), the next on-time will not initiate until the current drops below 1.8A (assume the voltage at the FB pin is lower than 0.8 V). During each on-time the current ramps up an amount equal to:

$$I_{LR} = \frac{(V_{IN} - V_{OUT}) \times t_{on}}{L} \quad (6)$$

During current limit, the LMR24210 operates in a constant current mode with an average output current $I_{OUT(CL)}$ equal to $1.8 \text{ A} + I_{LR} / 2$.

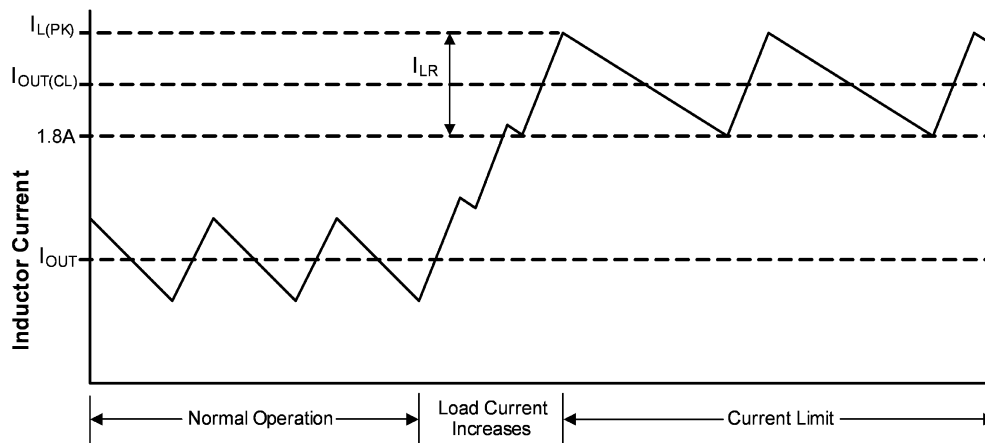
Feature Description (continued)

Figure 18. Inductor Current - Current Limit Operation
7.3.8 N-Channel Mosfet and Driver

The LMR24210 integrates an N-channel main MOSFET and an associated floating high voltage main MOSFET gate driver. The gate drive circuit works in conjunction with an external bootstrap capacitor C_{BST} and an internal high voltage diode. C_{BST} connecting between the BST and SW pins powers the main MOSFET gate driver during the main MOSFET on-time. During each off-time, the voltage of the SW pin falls to approximately -1 V, and C_{BST} charges from V_{CC} through the internal diode. The minimum off-time of 260 ns provides enough time for charging C_{BST} in each cycle.

7.3.9 Soft Start

The soft-start feature allows the converter to gradually reach a steady state operating point, thereby reducing startup stresses and current surges. Upon turnon, after V_{CC} reaches the undervoltage threshold, an $8\text{-}\mu\text{A}$ internal current source charges up an external capacitor C_{SS} connecting to the SS pin. The ramping voltage at the SS pin (and the non-inverting input of the regulation comparator as well) ramps up the output voltage V_{OUT} in a controlled manner.

The soft start time duration to reach steady state operation is given by the formula:

$$t_{SS} = V_{REF} \times C_{SS} / 8 \mu\text{A} = 0.8 \text{ V} \times C_{SS} / 8 \mu\text{A} \quad (7)$$

This equation can be rearranged as follows:

$$C_{SS} = t_{SS} \times 8 \mu\text{A} / 0.8 \text{ V} \quad (8)$$

Use of a 4.7-nF capacitor results in a 0.5-ms soft-start duration. This is a recommended value. Note that high values of C_{SS} capacitance causes more output voltage drop when a load transient goes across the DCM-CCM boundary. If a fast load transient response is desired for steps between DCM and CCM mode the softstart capacitor value must be less than 18 nF (which corresponds to a soft-start time of 1.8 ms).

An internal switch grounds the SS pin if any of the following three cases happens: (i) V_{CC} is below the UVLO threshold; (ii) a thermal shutdown occurs; or (iii) the EN pin is grounded. Alternatively, the output voltage can be shut off by connecting the SS pin to ground using an external switch. Releasing the switch allows the SS pin to ramp up and the output voltage to return to normal. The shutdown configuration is shown in [Figure 19](#).

Feature Description (continued)

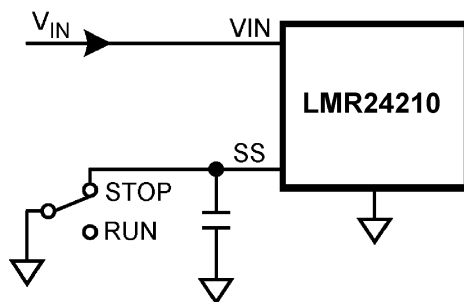

Figure 19. Alternate Shutdown Implementation

7.3.10 Thermal Protection

The junction temperature of the LMR24210 should not exceed the maximum limit. Thermal protection is implemented by an internal Thermal Shutdown circuit, which activates (typically) at 165°C to make the controller enter a low power reset state by disabling the main MOSFET, disabling the on-timer, and grounding the SS pin. Thermal protection helps prevent catastrophic failures from accidental device overheating. When the junction temperature falls back below 145°C (typical hysteresis = 20°C), the SS pin is released, and normal operation resumes.

7.3.11 Thermal Derating

Temperature rise increases with frequency, load current, input voltage and smaller board dimensions. On a typical board, the LMR24210 is capable of supplying 1 A below an ambient temperature of 90°C under worst case operation with input voltage of 42 V. Figure 20 shows a thermal derating curve for the output current without thermal shutdown against ambient temperature up to 125°C. Obtaining 1-A output current is possible at higher temperature by increasing the PCB ground plane area, adding airflow or reducing the input voltage or operating frequency.

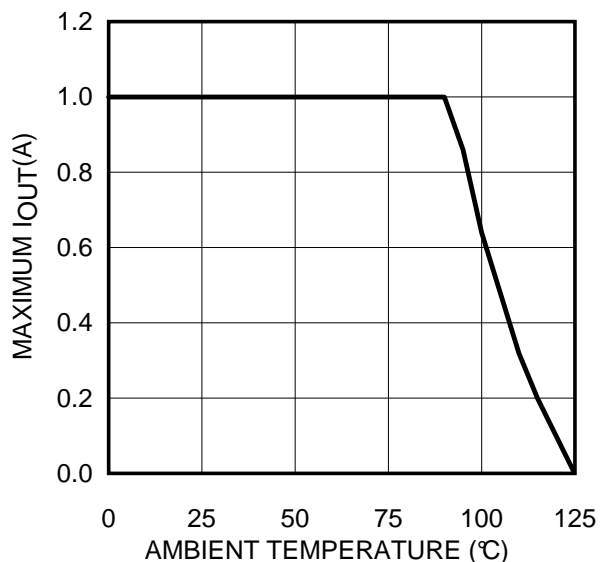

$\theta_{JA}=40^{\circ}\text{C}/\text{W}$, $V_{OUT} = 3.3 \text{ V}$, $f_{SW} = 500 \text{ kHz}$.
(tested on the evaluation board)

Figure 20. Thermal Derating Curve

8 Application and Implementation

NOTE

Information in the following applications sections is not part of the TI component specification, and TI does not warrant its accuracy or completeness. TI's customers are responsible for determining suitability of components for their purposes. Customers should validate and test their design implementation to confirm system functionality.

8.1 Application Information

The LMR24210 voltage regulator features all required functions to implement a highly efficient and cost-effective buck regulator. It is capable of supplying 1 A to loads with an output voltage as low as 0.8 V. Dual N-channel synchronous MOSFET switches allow a low component count, thus reducing complexity and minimizing board size.

8.2 Typical Application

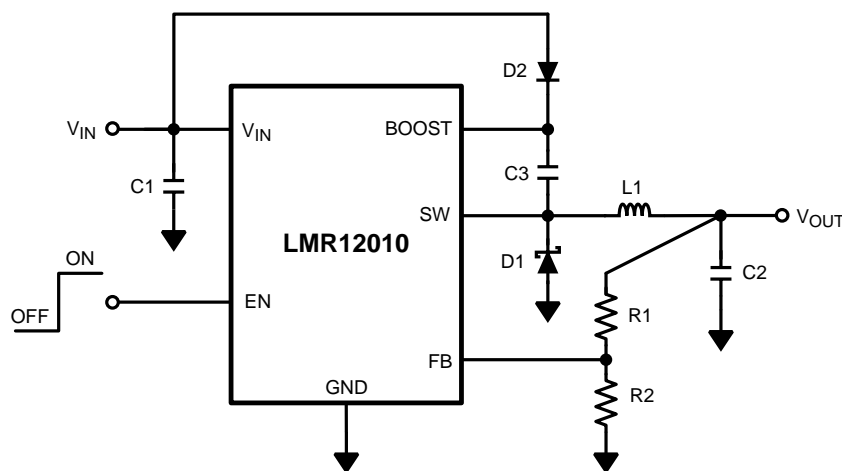

Figure 21. Typical Application Schematic

8.2.1 Detailed Design Procedure

8.2.1.1 Custom Design With WEBENCH® Tools

[Click here](#) to create a custom design using the LMR24010 device with the WEBENCH® Power Designer.

1. Start by entering the input voltage (V_{IN}), output voltage (V_{OUT}), and output current (I_{OUT}) requirements.
2. Optimize the design for key parameters such as efficiency, footprint, and cost using the optimizer dial.
3. Compare the generated design with other possible solutions from Texas Instruments.

The WEBENCH Power Designer provides a customized schematic along with a list of materials with real-time pricing and component availability.

In most cases, these actions are available:

- Run electrical simulations to see important waveforms and circuit performance
- Run thermal simulations to understand board thermal performance
- Export customized schematic and layout into popular CAD formats
- Print PDF reports for the design, and share the design with colleagues

Get more information about WEBENCH tools at www.ti.com/WEBENCH.

Typical Application (continued)

8.2.1.2 External Components

The following guidelines can be used to select external components.

R_{FB1} and R_{FB2}: Choose these resistors from standard values in the range of 1 kΩ to 10 kΩ, satisfying the following ratio:

$$R_{FB1} / R_{FB2} = (V_{OUT} / 0.8 V) - 1 \quad (9)$$

For $V_{OUT} = 0.8 V$, the FB pin can be connected to the output directly with a pre-load resistor drawing more than 20 μA. This is needed because the converter operation needs a minimum inductor current ripple to maintain good regulation when no load is connected.

R_{ON}: Equation 2 can be used to select R_{ON} if a desired operating frequency is selected. But the minimum value of R_{ON} is determined by the minimum on-time. It can be calculated as follows:

$$R_{ON} \geq \frac{V_{IN(MAX)} \times 150 \text{ ns}}{1.3 \times 10^{-10}} \quad (10)$$

If R_{ON} calculated from Equation 2 is smaller than the minimum value determined in Equation 10, select a lower frequency to re-calculate R_{ON} by Equation 2. Alternatively, V_{IN(MAX)} can also be limited in order to keep the frequency unchanged. The relationship of V_{IN(MAX)} and R_{ON} is shown in Figure 22.

On the other hand, the minimum off-time of 260 ns can limit the maximum duty ratio.

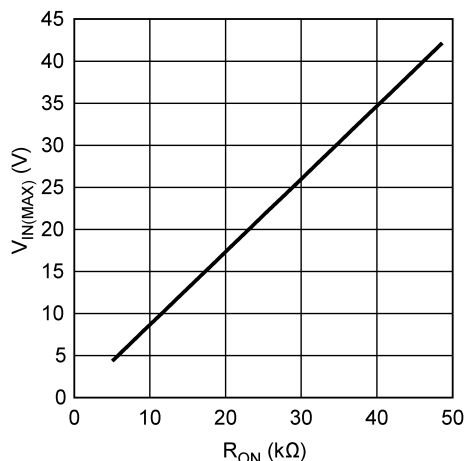

Figure 22. Maximum V_{IN} For Selected R_{ON}

L: The main parameter affected by the inductor is the amplitude of inductor current ripple (I_{LR}). Once I_{LR} is selected, L can be determined by:

$$L = \frac{V_{OUT} \times (V_{IN} - V_{OUT})}{I_{LR} \times f_{SW} \times V_{IN}}$$

where

- V_{IN} is the maximum input voltage and
- f_{SW} is determined from Equation 2. (11)

If the output current I_{OUT} is determined, by assuming that I_{OUT} = I_L, the higher and lower peak of I_{LR} can be determined. Beware that the higher peak of I_{LR} should not be larger than the saturation current of the inductor and current limits of the main and synchronous MOSFETs. Also, the lower peak of I_{LR} must be positive if CCM operation is required.

Typical Application (continued)

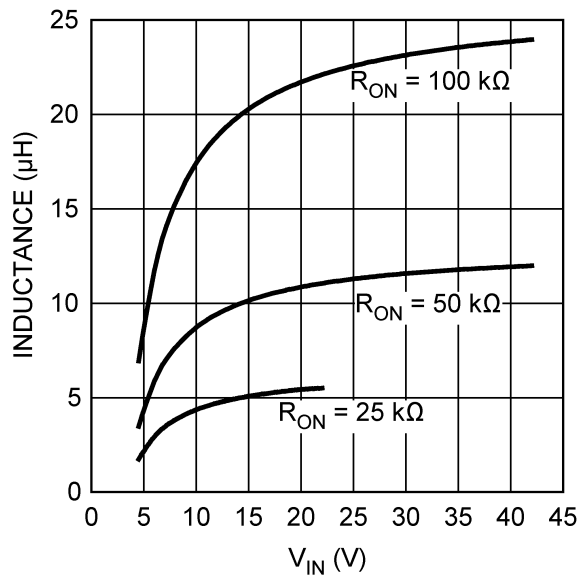

Figure 23. Inductor Selection for V_{OUT} = 3.3 V

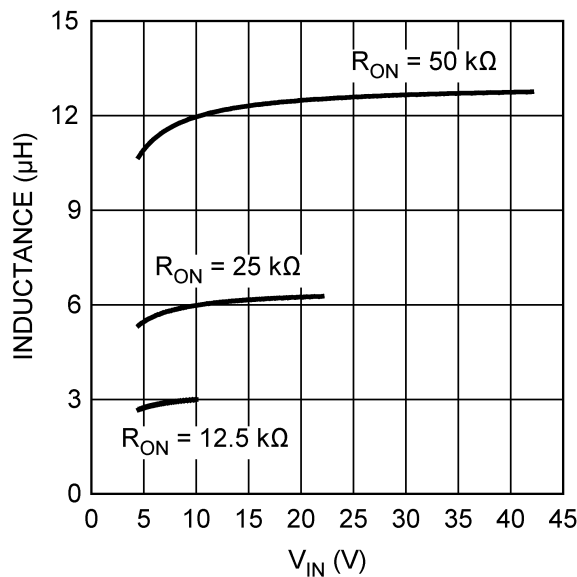

Figure 24. Inductor Selection for V_{OUT} = 0.8 V

Figure 23 and Figure 24 show curves on inductor selection for various V_{OUT} and R_{ON}. For small R_{ON}, according to Equation 10, V_{IN} is limited. Some curves are therefore limited as shown in the figures.

C_{VCC}: The capacitor on the V_{CC} output provides not only noise filtering and stability, but also prevents false triggering of the V_{CC} UVLO at the main MOSFET on/off transitions. C_{VCC} should be no smaller than 680 nF for stability, and should be a good quality, low ESR, ceramic capacitor.

C_{OUT} and C_{OUT3}: C_{OUT} should generally be no smaller than 10 µF. Experimentation is usually necessary to determine the minimum value for C_{OUT}, as the nature of the load may require a larger value. A load which creates significant transients requires a larger C_{OUT} than a fixed load.

C_{OUT3} is a small value ceramic capacitor located close to the LMR24210 to further suppress high frequency noise at V_{OUT}. TI recommends a 100-nF capacitor.

Typical Application (continued)

C_{IN} and C_{IN3}: The function of C_{IN} is to supply most of the main MOSFET current during the on-time, and limit the voltage ripple at the VIN pin, assuming that the voltage source connecting to the VIN pin has finite output impedance. If the voltage source’s dynamic impedance is high (effectively a current source), C_{IN} supplies the average input current, but not the ripple current.

At the maximum load current, when the main MOSFET turns on, the current to the VIN pin suddenly increases from zero to the lower peak of the inductor’s ripple current and ramps up to the higher peak value. It then drops to zero at turn-off. The average current during the on-time is the load current. For a worst case calculation, C_{IN} must be capable of supplying this average load current during the maximum on-time. C_{IN} is calculated from:

$$C_{IN} = \frac{I_{OUT} \times t_{on}}{\Delta V_{IN}}$$

where

- I_{OUT} is the load current
 - t_{on} is the maximum on-time
 - ΔV_{IN} is the allowable ripple voltage at V_{IN}
- (12)

The purpose of the C_{IN3} is to help avoid transients and ringing due to long lead inductance at the VIN pin. A low ESR 0.1-μF ceramic chip capacitor located close to the LMR24210 is recommended.

C_{BST}: A 33-nF high-quality ceramic capacitor with low ESR is recommended for C_{BST} since it supplies a surge current to charge the main MOSFET gate driver at turnon. Low ESR also helps ensure a complete recharge during each off-time.

C_{SS}: The capacitor at the SS pin determines the soft-start time; that is, the time for the reference voltage at the regulation comparator and the output voltage to reach their final value. The time is determined from [Equation 13](#):

$$t_{SS} = \frac{C_{SS} \times 0.8V}{8 \mu A}$$

(13)

C_{FB}: If the output voltage is higher than 1.6 V, C_{FB} is needed in the DCM to reduce the output ripple. The recommended value for C_{FB} is 10 nF.

8.2.2 Application Curve

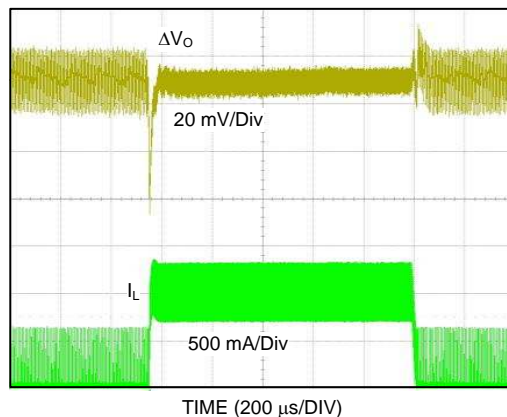

V_{OUT} = 3.3 V, 0.2 A to 1 A Load

Figure 25. Load Transient

9 Layout

9.1 Layout Considerations

The LMR24210 regulation, overvoltage, and current limit comparators are very fast and may respond to short duration noise pulses. Layout is therefore critical for optimum performance. It must be as neat and compact as possible, and all external components must be as close to their associated pins of the LMR24210 as possible. Refer to the [Functional Block Diagram](#), the loop formed by C_{IN} , the main and synchronous MOSFET internal to the LMR24210, and the PGND pin must be as small as possible. The connection from the PGND pin to C_{IN} must be as short and direct as possible. Add vias to connect the ground of C_{IN} to a ground plane, located as close as possible to the capacitor. The bootstrap capacitor C_{BST} should be connected as close to the SW and BST pins as possible, and the connecting traces should be thick. The feedback resistors and capacitor R_{FB1} , R_{FB2} , and C_{FB} must be close to the FB pin. A long trace running from V_{OUT} to R_{FB1} is generally acceptable since this is a low impedance node. Ground R_{FB2} directly to the AGND pin. Connect the output capacitor C_{OUT} to the load and tied directly to the ground plane. Connect the inductor L close to the SW pin with as short a trace as possible to reduce the potential for EMI (electromagnetic interference) generation. If it is expected that the internal dissipation of the LMR24210 produces excessive junction temperature during normal operation, making good use of the PC board's ground plane can help considerably to dissipate heat. Additionally the use of thick traces, where possible, can help conduct heat away from the LMR24210. Judicious positioning of the PC board within the end product, along with the use of any available air flow (forced or natural convection) can help reduce the junction temperature.

9.2 Layout Examples

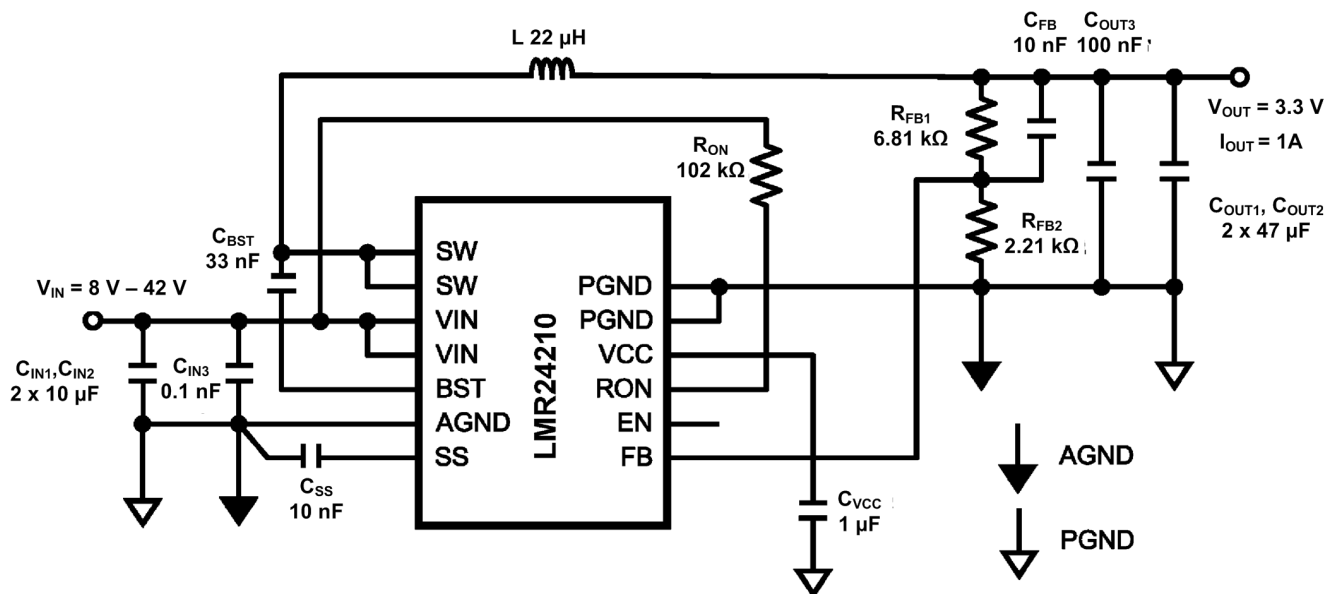

Figure 26. Typical Application Schematic for $V_{OUT} = 3.3 V$

Layout Examples (continued)

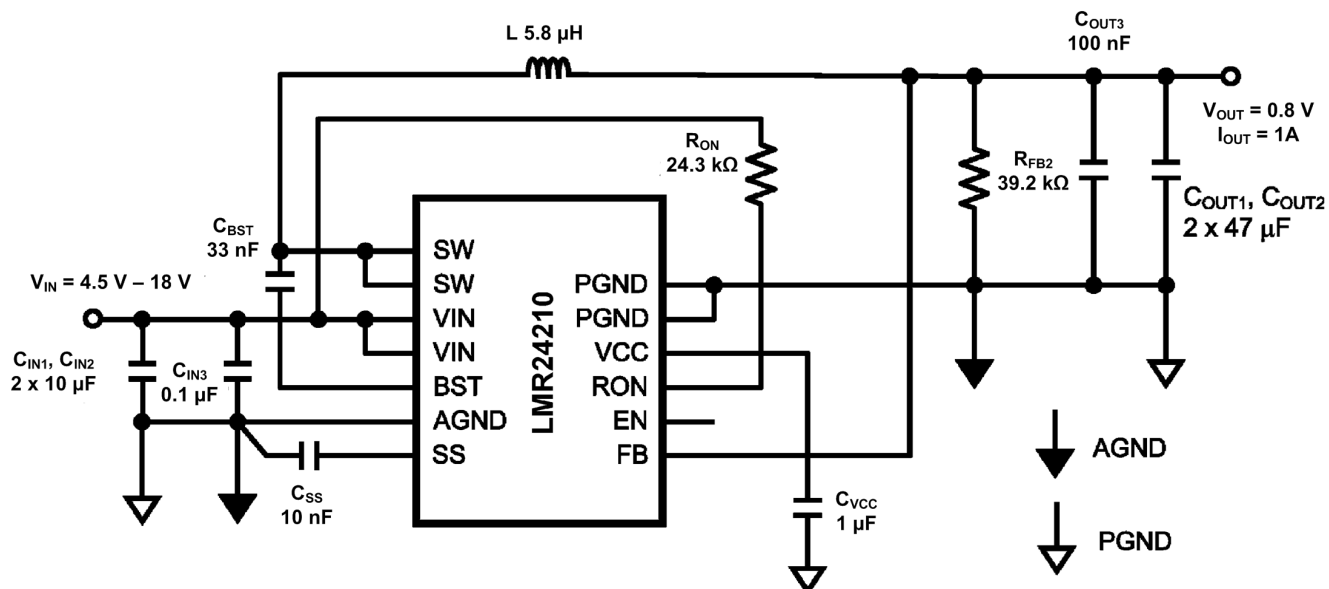

Figure 27. Typical Application Schematic for $V_{OUT} = 0.8\text{ V}$

9.3 Package Considerations

The die has exposed edges and can be sensitive to ambient light. For applications with direct high intensity ambient red, infrared, LED or natural light TI recommends shielding the device from the light source to avoid abnormal behavior.

10 器件和文档支持

10.1 器件支持

10.1.1 开发支持

10.1.1.1 使用 **WEBENCH®** 工具创建定制设计

单击[此处](#)，使用 LMR24010 器件并借助 WEBENCH® 电源设计器创建定制设计方案。

1. 首先输入输入电压 (V_{IN})、输出电压 (V_{OUT}) 和输出电流 (I_{OUT}) 要求。
2. 使用优化器拨盘优化该设计的关键参数，如效率、尺寸和成本。
3. 将生成的设计与德州仪器 (TI) 的其他可行的解决方案进行比较。

WEBENCH 电源设计器可提供定制原理图以及罗列实时价格和组件供货情况的物料清单。

在多数情况下，可执行以下操作：

- 运行电气仿真，观察重要波形以及电路性能
- 运行热性能仿真，了解电路板热性能
- 将定制原理图和布局方案以常用 CAD 格式导出
- 打印设计方案的 PDF 报告并与同事共享

有关 WEBENCH 工具的详细信息，请访问 www.ti.com.cn/WEBENCH。

10.2 接收文档更新通知

要接收文档更新通知，请导航至 TI.com.cn 上的器件产品文件夹。单击右上角的 *通知我* 进行注册，即可每周接收产品信息更改摘要。有关更改的详细信息，请查看任何已修订文档中包含的修订历史记录。

10.3 社区资源

The following links connect to TI community resources. Linked contents are provided "AS IS" by the respective contributors. They do not constitute TI specifications and do not necessarily reflect TI's views; see TI's [Terms of Use](#).

TI E2E™ Online Community *TI's Engineer-to-Engineer (E2E) Community*. Created to foster collaboration among engineers. At e2e.ti.com, you can ask questions, share knowledge, explore ideas and help solve problems with fellow engineers.

Design Support *TI's Design Support* Quickly find helpful E2E forums along with design support tools and contact information for technical support.

10.4 商标

E2E is a trademark of Texas Instruments.

WEBENCH is a registered trademark of Texas Instruments.

All other trademarks are the property of their respective owners.

10.5 静电放电警告



ESD 可能会损坏该集成电路。德州仪器 (TI) 建议通过适当的预防措施处理所有集成电路。如果不遵守正确的处理措施和安装程序，可能会损坏集成电路。

ESD 的损坏小至导致微小的性能降级，大至整个器件故障。精密的集成电路可能更容易受到损坏，这是因为非常细微的参数更改都可能会导致器件与其发布的规格不相符。

10.6 Glossary

SLYZ022 — *TI Glossary*.

This glossary lists and explains terms, acronyms, and definitions.

PACKAGING INFORMATION

Orderable Device	Status (1)	Package Type	Package Drawing	Pins	Package Qty	Eco Plan (2)	Lead finish/ Ball material (6)	MSL Peak Temp (3)	Op Temp (°C)	Device Marking (4/5)	Samples
LMR24210TL/NOPB	ACTIVE	DSBGA	YPA	28	250	RoHS & Green	SNAGCU	Level-1-260C-UNLIM	-40 to 125	SJ5B	Samples
LMR24210TLX/NOPB	ACTIVE	DSBGA	YPA	28	1000	RoHS & Green	SNAGCU	Level-1-260C-UNLIM	-40 to 125	SJ5B	Samples

(1) The marketing status values are defined as follows:

ACTIVE: Product device recommended for new designs.

LIFEBUY: TI has announced that the device will be discontinued, and a lifetime-buy period is in effect.

NRND: Not recommended for new designs. Device is in production to support existing customers, but TI does not recommend using this part in a new design.

PREVIEW: Device has been announced but is not in production. Samples may or may not be available.

OBSOLETE: TI has discontinued the production of the device.

(2) **RoHS:** TI defines "RoHS" to mean semiconductor products that are compliant with the current EU RoHS requirements for all 10 RoHS substances, including the requirement that RoHS substance do not exceed 0.1% by weight in homogeneous materials. Where designed to be soldered at high temperatures, "RoHS" products are suitable for use in specified lead-free processes. TI may reference these types of products as "Pb-Free".

RoHS Exempt: TI defines "RoHS Exempt" to mean products that contain lead but are compliant with EU RoHS pursuant to a specific EU RoHS exemption.

Green: TI defines "Green" to mean the content of Chlorine (Cl) and Bromine (Br) based flame retardants meet JS709B low halogen requirements of <=1000ppm threshold. Antimony trioxide based flame retardants must also meet the <=1000ppm threshold requirement.

(3) MSL, Peak Temp. - The Moisture Sensitivity Level rating according to the JEDEC industry standard classifications, and peak solder temperature.

(4) There may be additional marking, which relates to the logo, the lot trace code information, or the environmental category on the device.

(5) Multiple Device Markings will be inside parentheses. Only one Device Marking contained in parentheses and separated by a "~" will appear on a device. If a line is indented then it is a continuation of the previous line and the two combined represent the entire Device Marking for that device.

(6) Lead finish/Ball material - Orderable Devices may have multiple material finish options. Finish options are separated by a vertical ruled line. Lead finish/Ball material values may wrap to two lines if the finish value exceeds the maximum column width.

Important Information and Disclaimer:The information provided on this page represents TI's knowledge and belief as of the date that it is provided. TI bases its knowledge and belief on information provided by third parties, and makes no representation or warranty as to the accuracy of such information. Efforts are underway to better integrate information from third parties. TI has taken and continues to take reasonable steps to provide representative and accurate information but may not have conducted destructive testing or chemical analysis on incoming materials and chemicals. TI and TI suppliers consider certain information to be proprietary, and thus CAS numbers and other limited information may not be available for release.

In no event shall TI's liability arising out of such information exceed the total purchase price of the TI part(s) at issue in this document sold by TI to Customer on an annual basis.

TAPE AND REEL INFORMATION

QUADRANT ASSIGNMENTS FOR PIN 1 ORIENTATION IN TAPE

*All dimensions are nominal

Device	Package Type	Package Drawing	Pins	SPQ	Reel Diameter (mm)	Reel Width W1 (mm)	A0 (mm)	B0 (mm)	K0 (mm)	P1 (mm)	W (mm)	Pin1 Quadrant
LMR24210TL/NOPB	DSBGA	YPA	28	250	178.0	12.4	2.64	3.84	0.76	8.0	12.0	Q1
LMR24210TLX/NOPB	DSBGA	YPA	28	1000	178.0	12.4	2.64	3.84	0.76	8.0	12.0	Q1

TAPE AND REEL BOX DIMENSIONS

*All dimensions are nominal

Device	Package Type	Package Drawing	Pins	SPQ	Length (mm)	Width (mm)	Height (mm)
LMR24210TL/NOPB	DSBGA	YPA	28	250	208.0	191.0	35.0
LMR24210TLX/NOPB	DSBGA	YPA	28	1000	208.0	191.0	35.0

YPA0028

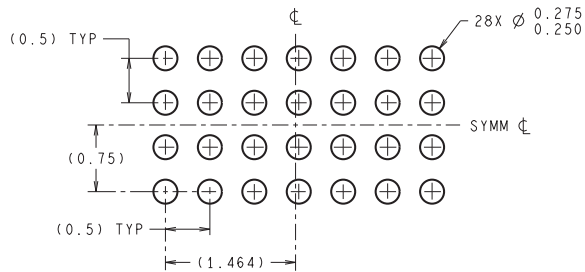

LAND PATTERN RECOMMENDATION

DIMENSIONS ARE IN MILLIMETERS
DIMENSIONS IN () FOR REFERENCE ONLY

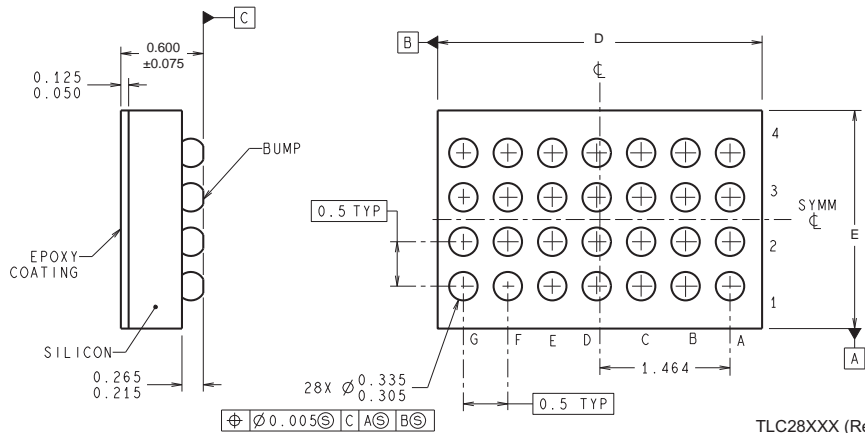
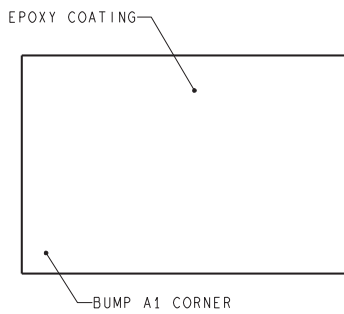

TLC28XXX (Rev A)

D: Max = 3.676 mm, Min = 3.615 mm
E: Max = 2.48 mm, Min = 2.419 mm

4215064/A 12/12

NOTES: A. All linear dimensions are in millimeters. Dimensioning and tolerancing per ASME Y14.5M-1994.
B. This drawing is subject to change without notice.

重要通知和免责声明

TI“按原样”提供技术和可靠性数据（包括数据表）、设计资源（包括参考设计）、应用或其他设计建议、网络工具、安全信息和其他资源，不保证没有瑕疵且不做任何明示或暗示的担保，包括但不限于对适销性、某特定用途方面的适用性或不侵犯任何第三方知识产权的暗示担保。

这些资源可供使用 TI 产品进行设计的熟练开发人员使用。您将自行承担以下全部责任：(1) 针对您的应用选择合适的 TI 产品，(2) 设计、验证并测试您的应用，(3) 确保您的应用满足相应标准以及任何其他功能安全、信息安全、监管或其他要求。

这些资源如有变更，恕不另行通知。TI 授权您仅可将这些资源用于研发本资源所述的 TI 产品的相关应用。严禁以其他方式对这些资源进行复制或展示。您无权使用任何其他 TI 知识产权或任何第三方知识产权。您应全额赔偿因在这些资源的使用中对 TI 及其代表造成的任何索赔、损害、成本、损失和债务，TI 对此概不负责。

TI 提供的产品受 [TI 的销售条款](#) 或 [ti.com](#) 上其他适用条款/TI 产品随附的其他适用条款的约束。TI 提供这些资源并不会扩展或以其他方式更改 TI 针对 TI 产品发布的适用的担保或担保免责声明。

TI 反对并拒绝您可能提出的任何其他或不同的条款。

邮寄地址：Texas Instruments, Post Office Box 655303, Dallas, Texas 75265
版权所有 © 2025，德州仪器 (TI) 公司