

## 具有脉冲计数接口的 LMT01 0.5°C 精度双引脚数字输出温度传感器

### 1 特性

- 在  $-50^{\circ}\text{C}$  至  $150^{\circ}\text{C}$  宽温度范围内保持高精度
  - $-20^{\circ}\text{C}$  至  $90^{\circ}\text{C}$ :  $\pm 0.5^{\circ}\text{C}$  (最大值)
  - $90^{\circ}\text{C}$  至  $150^{\circ}\text{C}$ :  $\pm 0.625^{\circ}\text{C}$  (最大值)
  - $-50^{\circ}\text{C}$  至  $-20^{\circ}\text{C}$ :  $\pm 0.7^{\circ}\text{C}$  (最大值)
- 通过双引脚封装简化精密数字温度测量
- 脉冲计数电流环路可由处理器轻松读取。输出脉冲数采用与温度成正比的, 分辨率为  $0.0625^{\circ}\text{C}$
- 通信频率:  $88\text{kHz}$
- 转换电流:  $34\mu\text{A}$
- 每次转换的连续加数据传输时间:  $100\text{ms}$
- 由具有集成 EMI 抗扰度的  $2\text{V}$  至  $5.5\text{V}$  (VP-VN) 悬空电源供电运行
- 多种双引脚封装产品: TO-92/LPG ( $3.1\text{mm} \times 4\text{mm} \times 1.5\text{mm}$ ) – 尺寸为传统 TO-92 和具有可湿性侧面的 WSON 的一半

### 2 应用

- 数字输出接线探针
- 白色家电
- 暖通空调 (HVAC)
- 电源
- 电池管理

### 3 说明

LMT01 器件是一款高精度双引脚温度传感器, 具备一个易于使用的脉冲计数电流环路接口, 因此适用于汽车、工业和消费品市场中的板载和非板载应用。LMT01 具有数字脉冲计数输出, 可在宽温度范围内实现高精度, 因此适合与所有 MCU 配对使用, 不仅能够降低软件开销, 而且不会影响集成 ADC 的质量或可用性。TI 的 LMT01 器件在  $-20^{\circ}\text{C}$  至  $90^{\circ}\text{C}$  的温度范围内支持  $\pm 0.5^{\circ}\text{C}$  的最大精度, 同时具有极高的分辨率 ( $0.0625^{\circ}\text{C}$ ), 无需借助系统校准或软硬件补偿。

LMT01 的脉冲计数接口设计用于直接连接 GPIO 或比较器输入, 从而简化硬件实施。同样, LMT01 具备集成的 EMI 抑制功能和简单的双引脚架构, 因而适用于噪声环境中的板载和非板载温度传感。LMT01 器件可轻松转换成双线温度探针, 电线长度可达两米。请参阅符合汽车要求的 LMT01-Q1 版本。

器件信息(1)

器件型号	封装	封装尺寸 (标称值)
LMT01LPG	TO-92 (2)	$4.00\text{mm} \times 3.15\text{mm}$
LMT01DQX	WSON (2)	$1.70\text{mm} \times 2.50\text{mm}$

(1) 如需了解所有可用封装, 请参阅数据表末尾的可订购产品附录。

LMT01 精度

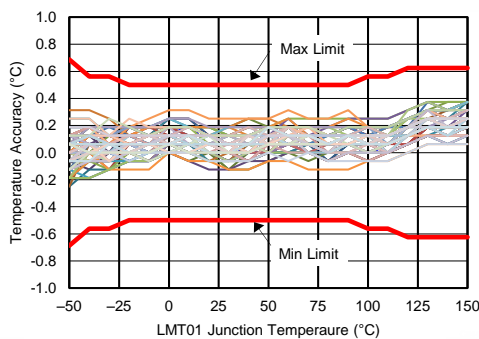

在曲线中心绘制的典型单元

双引脚集成电路 (IC) 温度传感器

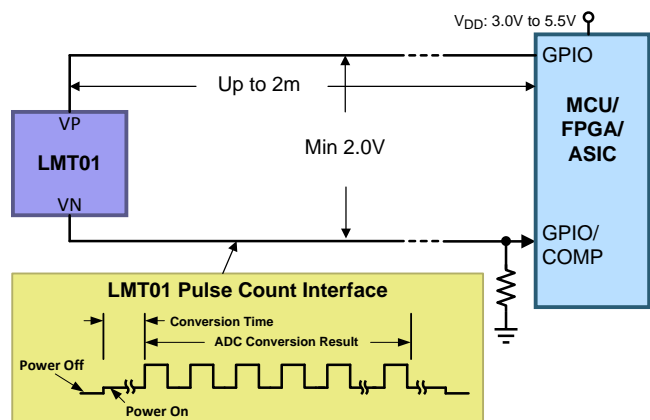

## 目录

<ul style="list-style-type: none"> <li>1 特性 ..... 1</li> <li>2 应用 ..... 1</li> <li>3 说明 ..... 1</li> <li>4 修订历史记录 ..... 2</li> <li>5 <b>Pin Configuration and Functions</b> ..... 3</li> <li>6 <b>Specifications</b> ..... 4           <ul style="list-style-type: none"> <li>6.1 Absolute Maximum Ratings ..... 4</li> <li>6.2 ESD Ratings ..... 4</li> <li>6.3 Recommended Operating Conditions ..... 4</li> <li>6.4 Thermal Information ..... 4</li> <li>6.5 Electrical Characteristics ..... 5</li> <li>6.6 Electrical Characteristics - TO-92/LPG Pulse Count to Temperature LUT ..... 6</li> <li>6.7 Electrical Characteristics - WSON/DQX Pulse Count to Temperature LUT ..... 7</li> <li>6.8 Switching Characteristics ..... 7</li> <li>6.9 Timing Diagram ..... 8</li> <li>6.10 Typical Characteristics ..... 9</li> </ul> </li> <li>7 <b>Detailed Description</b> ..... 13</li> </ul>	<ul style="list-style-type: none"> <li>7.1 Overview ..... 13</li> <li>7.2 Functional Block Diagram ..... 13</li> <li>7.3 Feature Description ..... 13</li> <li>7.4 Device Functional Modes ..... 16</li> <li>8 <b>Application and Implementation</b> ..... 17           <ul style="list-style-type: none"> <li>8.1 Application Information ..... 17</li> <li>8.2 Typical Application ..... 18</li> <li>8.3 System Examples ..... 20</li> </ul> </li> <li>9 <b>Power Supply Recommendations</b> ..... 22</li> <li>10 <b>Layout</b> ..... 23           <ul style="list-style-type: none"> <li>10.1 Layout Guidelines ..... 23</li> <li>10.2 Layout Example ..... 23</li> </ul> </li> <li>11 <b>器件和文档支持</b> ..... 24           <ul style="list-style-type: none"> <li>11.1 接收文档更新通知 ..... 24</li> <li>11.2 社区资源 ..... 24</li> <li>11.3 商标 ..... 24</li> <li>11.4 静电放电警告 ..... 24</li> <li>11.5 术语表 ..... 24</li> </ul> </li> <li>12 <b>机械、封装和可订购信息</b> ..... 24</li> </ul>
---	---

## 4 修订历史记录

Changes from Revision C (June 2017) to Revision D	Page
• Added device stamp to the TO-92 pinout top view .....	3
• Changed the TO-92S pin numbers in the <i>Pin Functions</i> .....	3

Changes from Revision B (April 2017) to Revision C	Page
• Removed <i>Electrical Characteristics: WSON/DQX</i> table; Combined the LPG and DQX <i>Electrical Characteristics</i> tables together.....	5
• Changed $I_{OL}$ maximum value from: 39 $\mu$ A to: 40 $\mu$ A .....	5
• Changed leakage value from: 1 $\mu$ A to 3.5 $\mu$ A .....	5
• Moved the thermal response time parameters to the <i>Electrical Characteristics</i> table .....	5
• Added Missing Cross References .....	13

Changes from Revision A (June 2015) to Revision B	Page
• 已添加 全新 WSON/DQX 封装（整个数据表中） .....	1
• Changed updated package information. ....	3
• Added Electrical Characteristics - WSON/DQX Pulse Count to Temperature LUT .....	7
• Added -40 for Sample Calculations Table .....	14
• Added missing cross reference .....	15

Changes from Original (June 2015) to Revision A	Page
• 已添加 完整数据表。 .....	1
• 已添加 澄清说明。 .....	1

## 5 Pin Configuration and Functions

**DQX Package  
2-Pin WSON  
Bottom View**



**LPG Package  
2-Pin TO-92  
Top View**



### Pin Functions

NAME	PIN		TYPE	DESCRIPTION
	TO-92S	WSON		
VP	2	1	Input	Positive voltage pin; may be connected to system power supply or bias resistor.
VN	1	2	Output	Negative voltage pin; may be connected to system ground or a bias resistor.

## 6 Specifications

### 6.1 Absolute Maximum Ratings

 See <sup>(1)(2)</sup>.

	MIN	MAX	UNIT
Voltage drop (VP – VN)	–0.3	6	V
Storage temperature, T <sub>stg</sub>	–65	175	°C

- (1) Stresses beyond those listed under *Absolute Maximum Ratings* may cause permanent damage to the device. These are stress ratings only, which do not imply functional operation of the device at these or any other conditions beyond those indicated under *Recommended Operating Conditions*. Exposure to absolute-maximum-rated conditions for extended periods may affect device reliability.
- (2) Soldering process must comply with Reflow Temperature Profile specifications. Refer to [www.ti.com/packaging](http://www.ti.com/packaging).

### 6.2 ESD Ratings

		VALUE	UNIT
V <sub>(ESD)</sub> Electrostatic discharge	Human-body model (HBM), per ANSI/ESDA/JEDEC JS-001 <sup>(1)</sup>	±2000	V
	Charged-device model (CDM), per JEDEC specification JESD22-C101 <sup>(2)</sup>	±750	

- (1) JEDEC document JEP155 states that 500-V HBM allows safe manufacturing with a standard ESD control process.
- (2) JEDEC document JEP157 states that 250-V CDM allows safe manufacturing with a standard ESD control process.

### 6.3 Recommended Operating Conditions

	MIN	MAX	UNIT
Free-air temperature	–50	150	°C
Voltage drop (VP – VN)	2	5.5	V

### 6.4 Thermal Information

THERMAL METRIC <sup>(1)</sup>	LMT01		UNIT
	DQX (WSON)	LPG (TO-92)	
	2 PINS	2 PINS	
R <sub>θJA</sub> Junction-to-ambient thermal resistance	213	177	°C/W
R <sub>θJC(top)</sub> Junction-to-case (top) thermal resistance	71	94	°C/W
R <sub>θJB</sub> Junction-to-board thermal resistance	81	152	°C/W
ψ <sub>JT</sub> Junction-to-top characterization parameter	2.4	33	°C/W
ψ <sub>JB</sub> Junction-to-board characterization parameter	79	152	°C/W

- (1) For more information about traditional and new thermal metrics, see the *Semiconductor and IC Package Thermal Metrics* application report.

## 6.5 Electrical Characteristics

Over operating free-air temperature range and operating VP-VN range (unless otherwise noted).

PARAMETER		TEST CONDITIONS	MIN	TYP	MAX	UNIT
<b>ACCURACY</b>						
Temperature accuracy <sup>(1)(2)</sup>	VP – VN of 2.15 V to 5.5 V	150°C	–0.625		0.625	°C
		125°C	–0.625		0.625	°C
		120°C	–0.625		0.625	°C
		110°C	–0.5625		0.5625	°C
		100°C	–0.5625		0.5625	°C
		90°C	–0.5		0.5	°C
		25°C	–0.5	±0.125	0.5	°C
		–20°C	–0.5		0.5	°C
		–30°C	–0.5625		0.5625	°C
		–40°C	–0.625		0.625	°C
Temperature accuracy <sup>(1)(2)</sup>	VP – VN of 2.15 V to 5.5 V	–50°C	–0.6875	±0.4	0.6875	°C
<b>PULSE COUNT TRANSFER FUNCTION</b>						
Number of pulses at 0°C			800	808	816	
Output pulse range			15		3228	
		Theoretical max (exceeds device rating)	1		4095	
Resolution of one pulse			0.0625			°C
<b>OUTPUT CURRENT</b>						
I <sub>OL</sub>	Output current variation	Low level	28	34	40	μA
I <sub>OH</sub>		High level	112.5	125	143	μA
High-to-Low level output current ratio			3.1	3.7	4.5	
<b>POWER SUPPLY</b>						
Accuracy sensitivity to change in VP – VN		2.15 V ≤ VP – VN ≤ 5.0 V <sup>(3)</sup>		40	133	m°C/V
Leakage Current VP – VN		VDD ≤ 0.4 V		0.002	3.5	μA
<b>THERMAL RESPONSE</b>						
Stirred oil thermal response time to 63% of final value (package only)		DQX (WSON)	0.4		s	
		LPG (TO-92)	0.8			
Still air thermal response time to 63% of final value (package only)		DQX (WSON)	9.4		s	
		LPG (TO-92)	28			

- (1) Calculated using Pulse Count to Temperature LUT and 0.0625°C resolution per pulse, see section [Electrical Characteristics - TO-92/LPG Pulse Count to Temperature LUT](#) and [Electrical Characteristics - WSON/DQX Pulse Count to Temperature LUT](#).
- (2) Error can be linearly interpolated between temperatures given in table as shown in the Accuracy vs Temperature curves in section [Typical Characteristics](#).
- (3) Limit is using end point calculation.

## 6.6 Electrical Characteristics - TO-92/LPG Pulse Count to Temperature LUT

Over operating free-air temperature range and VP-VN operating range (unless otherwise noted). LUT is short for Look-up Table.

PARAMETER	TEST CONDITIONS	MIN	TYP	MAX	UNIT
Digital output code	–50°C	15	26	37	pulses
	–40°C	172	181	190	
	–30°C	329	338	347	
	–20°C	486	494	502	
	–10°C	643	651	659	
	0°C	800	808	816	
	10°C	958	966	974	
	20°C	1117	1125	1133	
	30°C	1276	1284	1292	
	40°C	1435	1443	1451	
	50°C	1594	1602	1610	
	60°C	1754	1762	1770	
	70°C	1915	1923	1931	
	80°C	2076	2084	2092	
	90°C	2237	2245	2253	
	100°C	2398	2407	2416	
	110°C	2560	2569	2578	
	120°C	2721	2731	2741	
	130°C	2883	2893	2903	
140°C	3047	3057	3067		
150°C	3208	3218	3228		

## 6.7 Electrical Characteristics - WSON/DQX Pulse Count to Temperature LUT

Over operating free-air temperature range and  $2.15\text{ V} \leq \text{VP} - \text{VN} \leq 5.0\text{ V}$  power supply operating range (unless otherwise noted). LUT is short for Look-up Table.

PARAMETER	TEST CONDITIONS	MIN	TYP	MAX	UNIT
Digital output code	-50°C	15	26	37	pulses
	-40°C	172	181	190	
	-30°C	328	337	346	
	-20°C	486	494	502	
	-10°C	643	651	659	
	0°C	800	808	816	
	10°C	958	966	974	
	20°C	1117	1125	1133	
	30°C	1276	1284	1292	
	40°C	1435	1443	1451	
	50°C	1594	1603	1611	
	60°C	1754	1762	1771	
	70°C	1915	1923	1931	
	80°C	2076	2084	2092	
	90°C	2237	2245	2254	
	100°C	2398	2407	2416	
	110°C	2560	2569	2578	
	120°C	2721	2731	2741	
	125°C	2802	2814	2826	
130°C	2883	2894	2904		
140°C	3047	3058	3068		
150°C	3210	3221	3231		

## 6.8 Switching Characteristics

Over operating free-air temperature range and operating  $\text{VP} - \text{VN}$  range (unless otherwise noted).

PARAMETER	TEST CONDITIONS	MIN	TYP	MAX	UNIT
$t_R, t_F$	Output current rise and fall time $C_L = 10\text{ pF}, R_L = 8\text{ k}$		1.45		$\mu\text{s}$
$f_P$	Output current pulse frequency	82	88	94	kHz
	Output current duty cycle	40%	50%	60%	
$t_{\text{CONV}}$	Temperature conversion time <sup>(1)</sup> 2.15 V to 5.5 V	46	50	54	ms
$t_{\text{DATA}}$	Data transmission time	44	47	50	ms

(1) Conversion time includes power up time or device turn on time that is typically 3 ms after POR threshold of 1.2 V is exceeded.

## 6.9 Timing Diagram

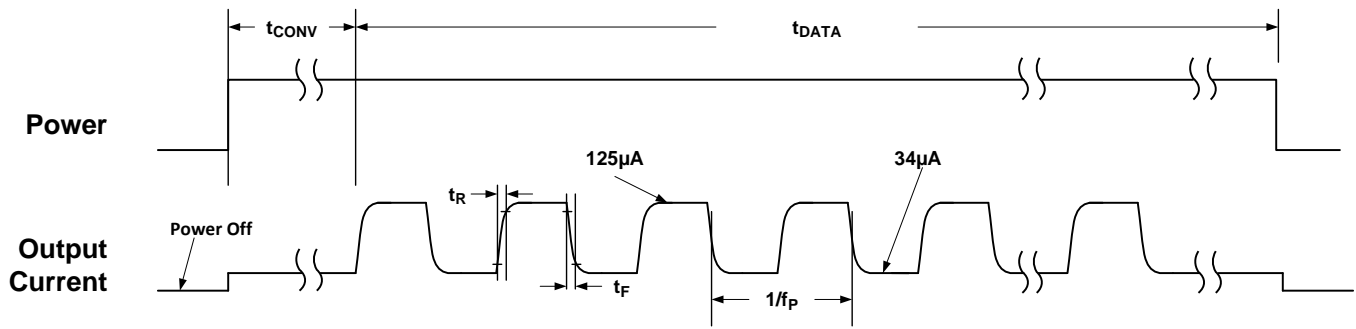

**Figure 1. Timing Specification Waveform**



## 6.10 Typical Characteristics

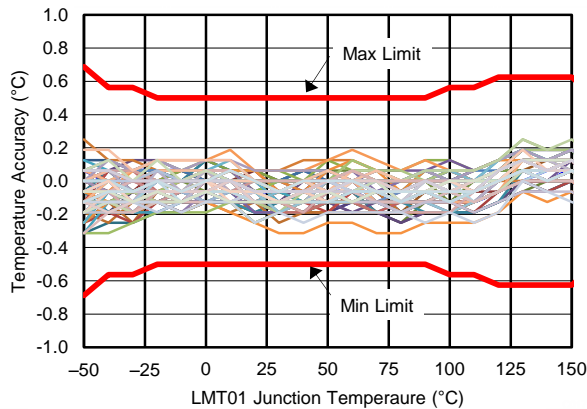

Using *Electrical Characteristics - TO-92/LPG Pulse Count to Temperature LUT*

VP – VN = 2.15 V

**Figure 2. Accuracy vs LMT01 Junction Temperature**

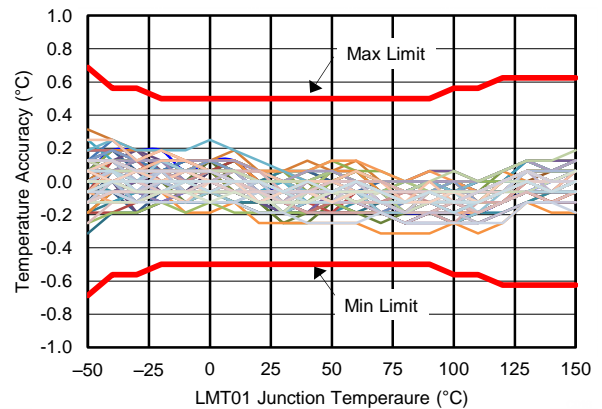

Using *Electrical Characteristics - TO-92/LPG Pulse Count to Temperature LUT*

VP – VN = 2.4 V

**Figure 3. Accuracy vs LMT01 Junction Temperature**

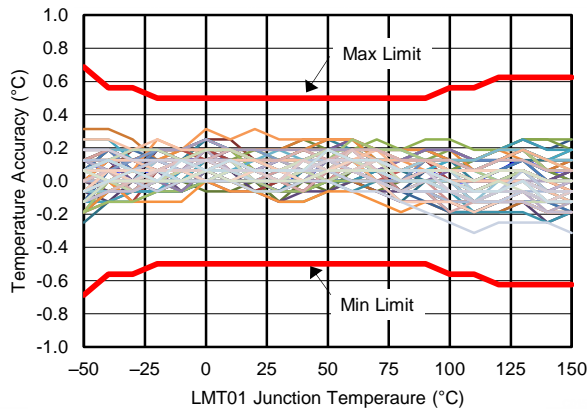

Using *Electrical Characteristics - TO-92/LPG Pulse Count to Temperature LUT*

VP – VN = 2.7 V

**Figure 4. Accuracy vs LMT01 Junction Temperature**

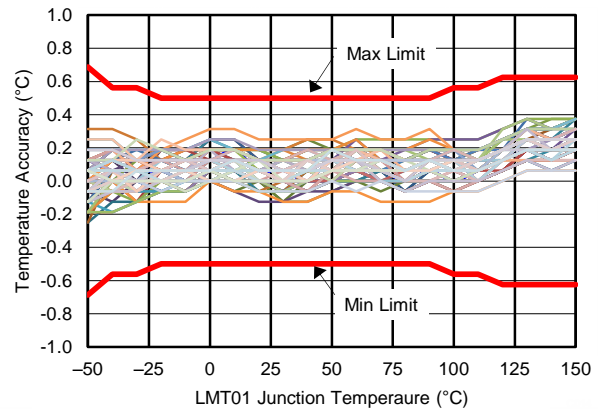

Using *Electrical Characteristics - TO-92/LPG Pulse Count to Temperature LUT*

VP – VN = 3 V

**Figure 5. Accuracy vs LMT01 Junction Temperature**

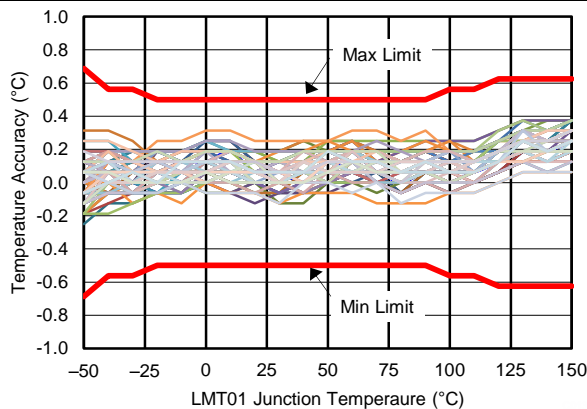

Using *Electrical Characteristics - TO-92/LPG Pulse Count to Temperature LUT*

VP – VN = 4 V

**Figure 6. Accuracy vs LMT01 Junction Temperature**

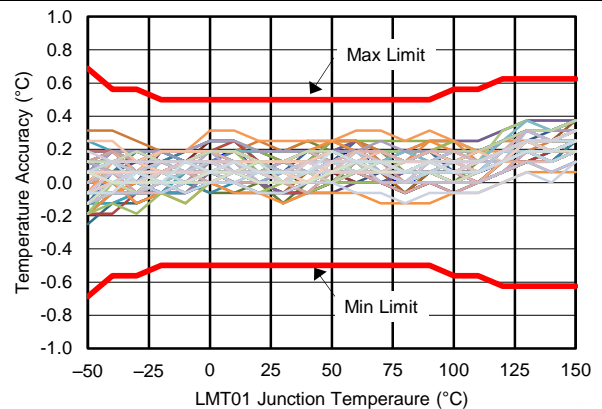

Using *Electrical Characteristics - TO-92/LPG Pulse Count to Temperature LUT*

VP – VN = 5 V

**Figure 7. Accuracy vs LMT01 Junction Temperature**

Typical Characteristics (continued)

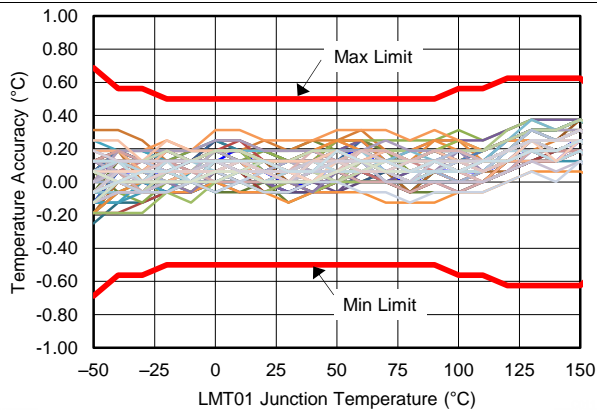

Using *Electrical Characteristics - TO-92/LPG Pulse Count to Temperature LUT*  
 VP – VN = 5.5 V

Figure 8. Accuracy vs LMT01 Junction Temperature

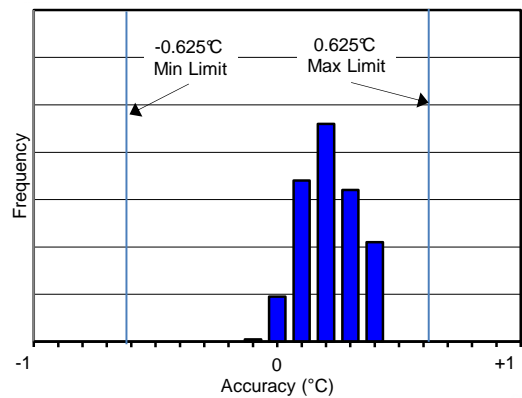

Using *Electrical Characteristics - TO-92/LPG Pulse Count to Temperature LUT*  
 VP – VN = 2.15 V to 5.5 V

Figure 9. Accuracy Histogram at 150°C

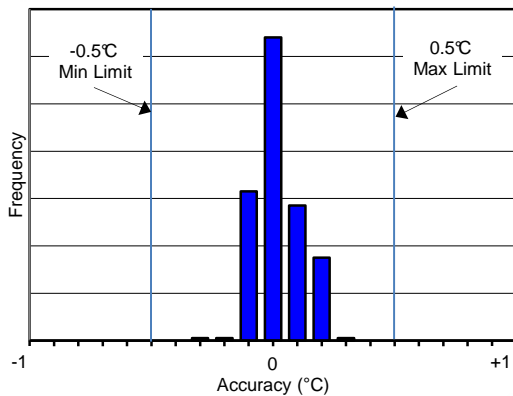

Using *Electrical Characteristics - TO-92/LPG Pulse Count to Temperature LUT*  
 VP – VN = 2.15 V to 5.5 V

Figure 10. Accuracy Histogram at 30°C

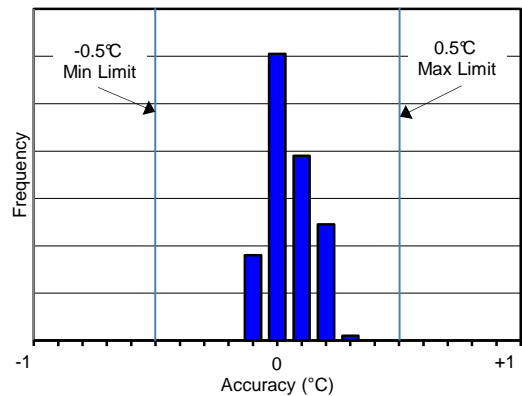

Using *Electrical Characteristics - TO-92/LPG Pulse Count to Temperature LUT*  
 VP – VN = 2.15 V to 5.5 V

Figure 11. Accuracy Histogram at -20°C

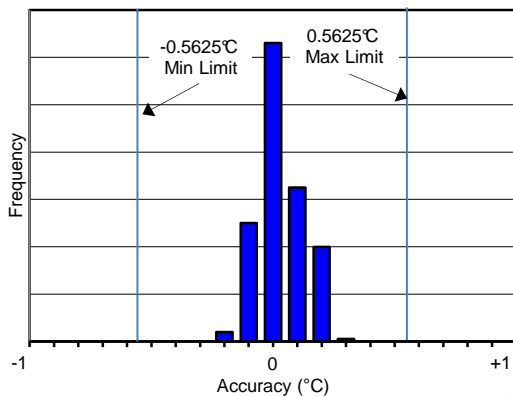

Using *LUT Electrical Characteristics - TO-92/LPG Pulse Count to Temperature LUT*  
 VP – VN = 2.15 V to 5.5 V

Figure 12. Accuracy Histogram at -30°C

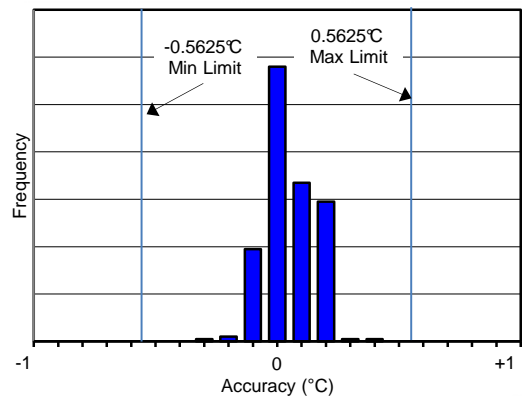

Using *Electrical Characteristics - TO-92/LPG Pulse Count to Temperature LUT*  
 VP – VN = 2.15 V to 5.5 V

Figure 13. Accuracy Histogram at -40°C

Typical Characteristics (continued)

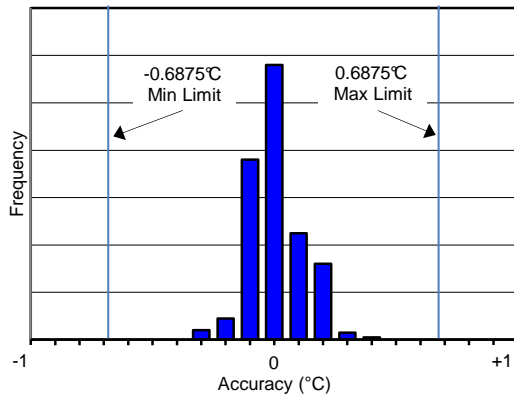

Using LUT [Electrical Characteristics - TO-92/LPG Pulse Count to Temperature LUT](#)  
 VP – VN = 2.15 V to 5.5 V

Figure 14. Accuracy Histogram at -50°C

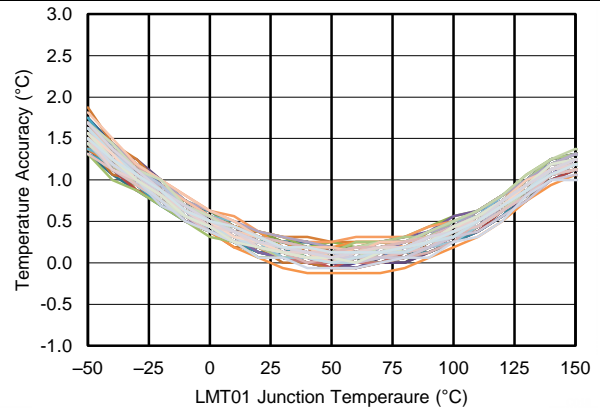

Using Temp = (PC/4096 × 256°C) – 50°C  
 VP – VN = 2.15 V

Figure 15. Accuracy Using Linear Transfer Function

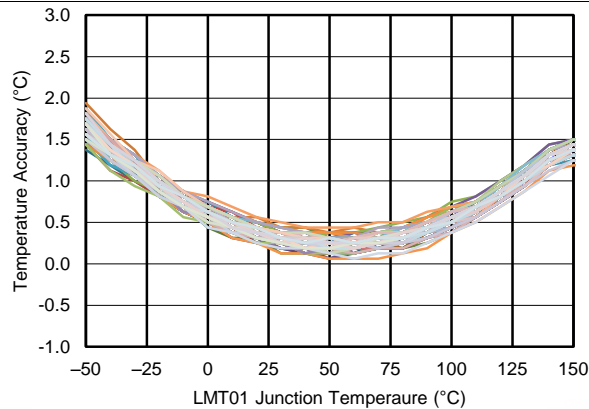

Using Temp = (PC/4096 × 256°C) – 50°C  
 VP – VN = 5.5V

Figure 16. Accuracy Using Linear Transfer Function

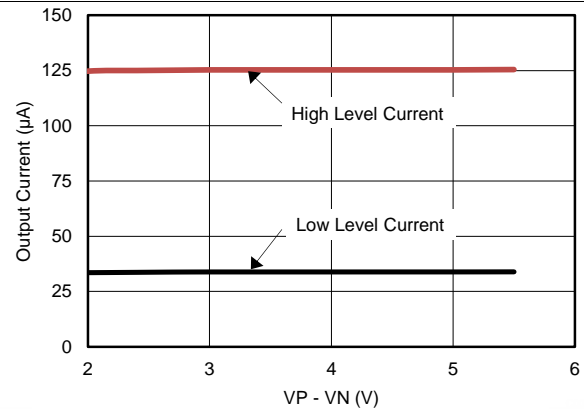

TA = 30°C

Figure 17. Output Current vs VP-VN Voltage

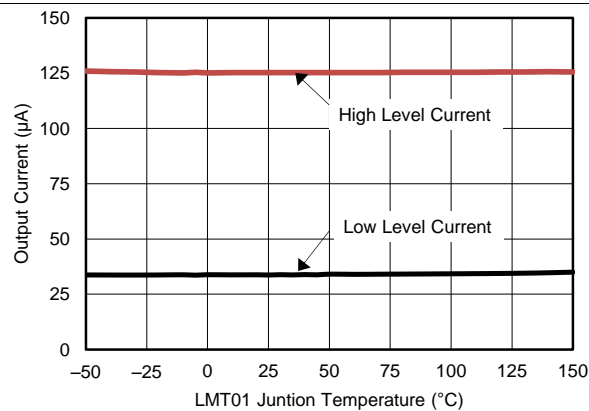

VP – VN = 3.3 V

Figure 18. Output Current vs Temperature

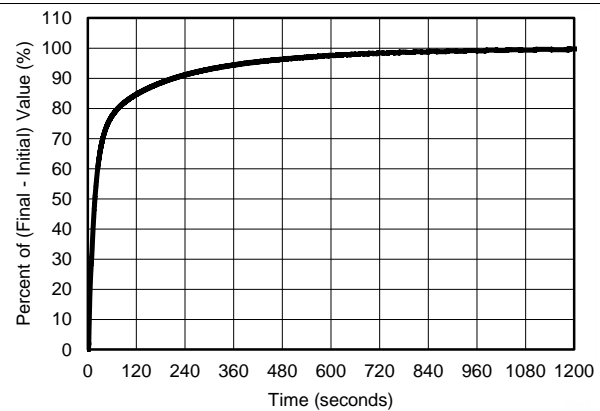

VP – VN = 3.3 V  
 T<sub>INITIAL</sub> = 23°C, T<sub>FINAL</sub> = 70°C

Figure 19. Thermal Response in Still Air (TO92S/LPG Package)

**Typical Characteristics (continued)**

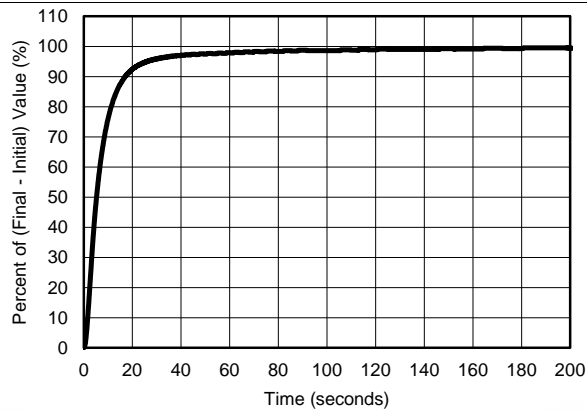

VP – VN = 3.3 V                      Air Flow = 2.34 meters/sec  
 T<sub>INITIAL</sub> = 23°C,                      T<sub>FINAL</sub> = 70°C

**Figure 20. Thermal Response in Moving Air (TO92S/LPG Package)**

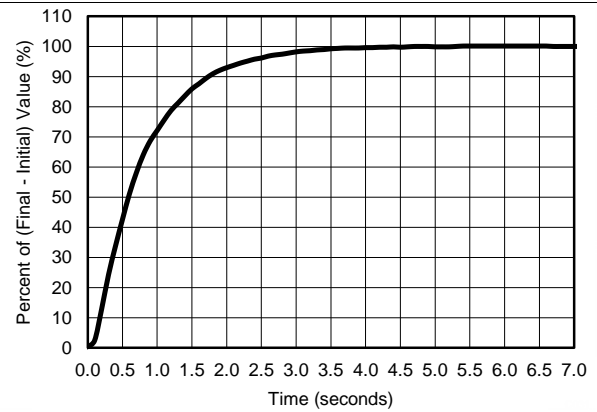

VP – VN = 3.3 V                      T<sub>INITIAL</sub> = 23°C,                      T<sub>FINAL</sub> = 70°C

**Figure 21. Thermal Response in Stirred Oil (TO92S/LPG Package)**

## 7 Detailed Description

### 7.1 Overview

The LMT01 temperature output is transmitted over a single wire using a train of current pulses that typically change from 34  $\mu\text{A}$  to 125  $\mu\text{A}$ . A simple resistor can then be used to convert the current pulses to a voltage. With a 10-k $\Omega$  resistor, the output voltage levels range from 340 mV to 1.25 V, typically. A simple microcontroller comparator or external transistor can be used convert this signal to valid logic levels the microcontroller can process properly through a GPIO pin. The temperature can be determined by gating a simple counter on for a specific time interval to count the total number of output pulses. After power is first applied to the device the current level will remain below 34  $\mu\text{A}$  for at most 54 ms while the LMT01 is determining the temperature. When the temperature is determined, the pulse train begins. The individual pulse frequency is typically 88 kHz. The LMT01 will continuously convert and transmit data when the power is applied approximately every 104 ms (maximum).

The LMT01 uses thermal diode analog circuitry to detect the temperature. The temperature signal is then amplified and applied to the input of a  $\Sigma\Delta$  ADC that is driven by an internal reference voltage. The  $\Sigma\Delta$  ADC output is then processed through the interface circuitry into a digital pulse train. The digital pulse train is then converted to a current pulse train by the output signal conditioning circuitry that includes high and low current regulators. The voltage applied across the pins of the LMT01 is regulated by an internal voltage regulator to provide a consistent Chip  $V_{\text{DD}}$  that is used by the ADC and its associated circuitry.

### 7.2 Functional Block Diagram

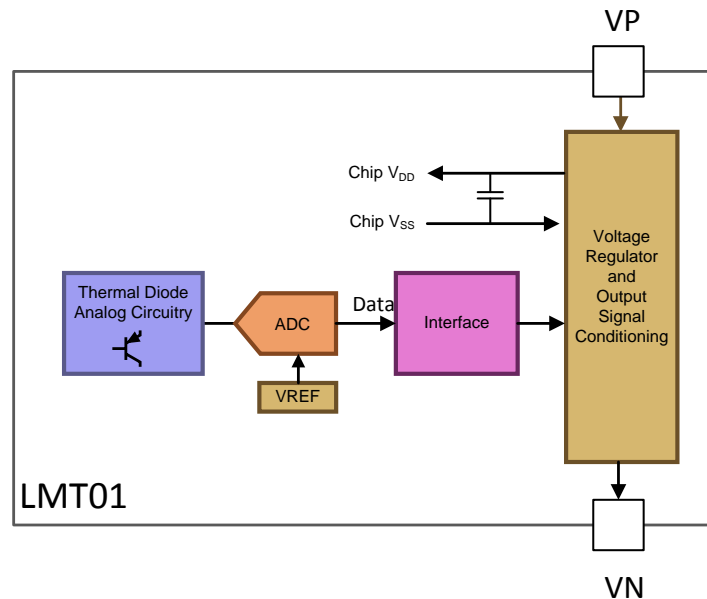

### 7.3 Feature Description

#### 7.3.1 Output Interface

The LMT01 provides a digital output in the form of a pulse count that is transmitted by a train of current pulses. After the LMT01 is powered up, it transmits a very low current of 34  $\mu\text{A}$  for less than 54 ms while the part executes a temperature to digital conversion, as shown in [Figure 22](#). When the temperature-to-digital conversion is complete, the LMT01 starts to transmit a pulse train that toggles from the low current of 34  $\mu\text{A}$  to a high current level of 125  $\mu\text{A}$ . The pulse train total time interval is at maximum 50 ms. The LMT01 transmits a series of pulses equivalent to the pulse count at a given temperature as described in [Electrical Characteristics - TO-92/LPG Pulse Count to Temperature LUT](#). After the pulse count has been transmitted the LMT01 current level will remain low for the remainder of the 50 ms. The total time for the temperature to digital conversion and the pulse train time interval is 104 ms (maximum). If power is continuously applied, the pulse train output will repeat start every 104 ms (maximum).

**Feature Description (continued)**

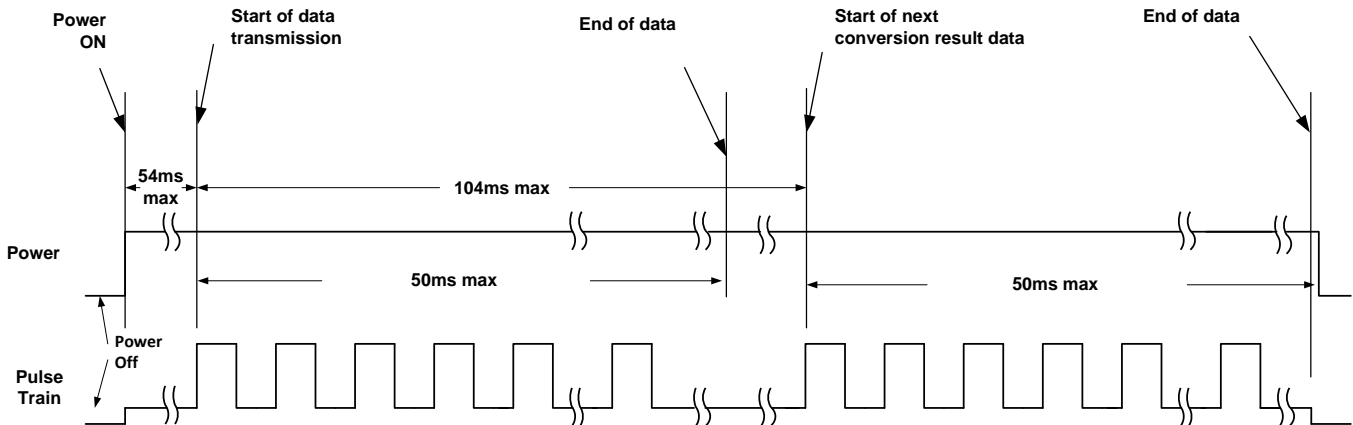

**Figure 22. Temperature to Digital Pulse Train Timing Cycle**

The LMT01 can be powered down at any time to conserve system power. Take care to ensure that a minimum power-down wait time of 50 ms is used before the device is turned on again.

**7.3.2 Output Transfer Function**

The LMT01 outputs at minimum 1 pulse and a theoretical maximum 4095 pulses. Each pulse has a weight of 0.0625°C. One pulse corresponds to a temperature less than -50°C while a pulse count of 4096 corresponds to a temperature greater than 200°C. Note that the LMT01 is only ensured to operate up to 150°C. Exceeding this temperature by more than 5°C may damage the device. The accuracy of the device degrades as well when 150°C is exceeded.

Two different methods of converting the pulse count to a temperature value are discussed in this section. The first method is the least accurate and uses a first order equation, and the second method is the most accurate and uses linear interpolation of the values found in the look-up table (LUT) as described in [Electrical Characteristics - TO-92/LPG Pulse Count to Temperature LUT](#).

The output transfer function appears to be linear and can be approximated by [Equation 1](#):

$$\text{Temp} = \left( \frac{\text{PC}}{4096} \times 256^\circ\text{C} \right) - 50^\circ\text{C}$$

where

- PC is the Pulse Count
- Temp is the temperature reading

(1)

[Table 1](#) shows some sample calculations using [Equation 1](#).

**Table 1. Sample Calculations Using Equation 1**

TEMPERATURE (°C)	NUMBER OF PULSES
-49.9375	1
-49.875	2
-40	160
-20	480
0	800
30	1280
50	1600
100	2400
150	3200

The curve shown in [Figure 23](#) shows the output transfer function using [Equation 1](#) (blue line) and the look-up table (LUT) found in [Electrical Characteristics - TO-92/LPG Pulse Count to Temperature LUT](#) (red line). The LMT01 output transfer function as described by the LUT appears to be linear, but upon close inspection, it can be seen as truly not linear. To actually see the difference, the accuracy obtained by the two methods must be compared.

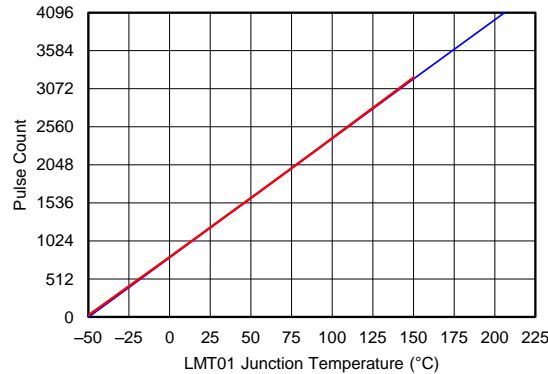

**Figure 23. LMT01 Output Transfer Function**

For more exact temperature readings the output pulse count can be converted to temperature using linear interpolation of the values found in [Electrical Characteristics - TO-92/LPG Pulse Count to Temperature LUT](#).

The curves in [Figure 24](#) and [Figure 25](#), show the accuracy of typical units when using the [Equation 1](#) and linear interpolation using [Electrical Characteristics - TO-92/LPG Pulse Count to Temperature LUT](#), respectively. When compared, the improved performance when using the LUT linear interpolation method can clearly be seen. For a limited temperature range of 25°C to 80°C, the error shown in [Figure 24](#) is flat, so the linear equation will provide good results. For a wide temperature range, TI recommends that linear interpolation and the LUT be used.

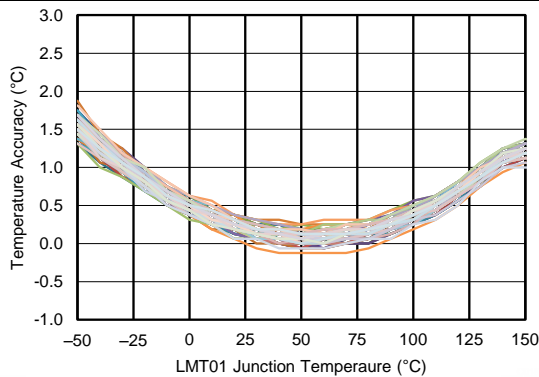

**Figure 24. LMT01 Typical Accuracy When Using First Order Equation [Equation 1](#) – 92 Typical Units Plotted at (VP – VN) = 2.15 V**

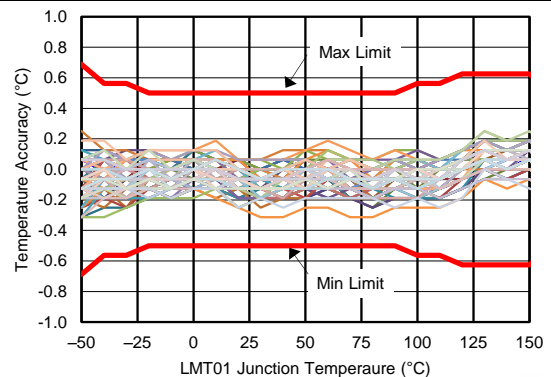

**Figure 25. LMT01 Accuracy Using Linear Interpolation of LUT Found In [Electrical Characteristics - TO-92/LPG Pulse Count to Temperature LUT](#) – 92 typical units plotted at (VP – VN) = 2.15 V**

### 7.3.3 Current Output Conversion to Voltage

The minimum voltage drop across the LMT01 must be maintained at 2.15 V during the conversion cycle. After the conversion cycle, the minimum voltage drop can decrease to 2.0 V. Thus the LMT01 can be used for low voltage applications. See [Application Information](#) for more information on low voltage operation and other information on picking the actual resistor value for different applications conditions. The resistor value is dependent on the power supply level and the variation and the threshold level requirements of the circuitry the resistor is driving (that is, MCU, GPIO, or Comparator).

## LMT01

ZHCSE14D – JUNE 2015 – REVISED JUNE 2018

www.ti.com.cn

Stray capacitance can be introduced when connecting the LMT01 through a long wire. This stray capacitance influences the signal rise and fall times. The wire inductance has negligible effect on the AC signal integrity. A simple RC time constant model as shown in [Figure 26](#) can be used to determine the rise and fall times.

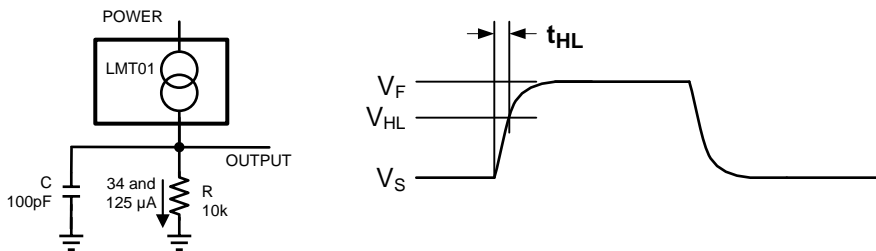

**Figure 26. Simple RC Model for Rise and Fall Times**

$$t_{HL} = R \times C \times \ln \left( \frac{V_F - V_S}{V_F - V_{HL}} \right)$$

where

- RC as shown in [Figure 26](#)
  - $V_{HL}$  is the target high level
  - the final voltage  $V_F = 125 \mu\text{A} \times R$
  - the start voltage  $V_S = 34 \mu\text{A} \times R$
- (2)

For the 10% to 90% level rise time ( $t_r$ ), [Equation 2](#) simplifies to:

$$t_r = R \times C \times 2.197$$

(3)

Take care to ensure that the LMT01 voltage drop does not exceed 300 mV under reverse bias conditions, as given in the [Absolute Maximum Ratings](#).

### 7.4 Device Functional Modes

The only functional mode the LMT01 has is that it provides a pulse count output that is directly proportional to temperature.



## 8 Application and Implementation

### NOTE

Information in the following applications sections is not part of the TI component specification, and TI does not warrant its accuracy or completeness. TI's customers are responsible for determining suitability of components for their purposes. Customers should validate and test their design implementation to confirm system functionality.

### 8.1 Application Information

#### 8.1.1 Mounting, Temperature Conductivity, and Self-Heating

The LMT01 can be applied easily in the same way as other integrated-circuit temperature sensors. It can be glued or cemented to a surface to ensure good temperature conductivity. The temperatures of the lands and traces to the leads of the LMT01 also affect the temperature reading, so they must be as thin as possible.

Alternatively, the LMT01 can be mounted inside a sealed-end metal tube, and then can be dipped into a bath or screwed into a threaded hole in a tank. As with any IC, the LMT01 and accompanying wiring and circuits must be kept insulated and dry to avoid excessive leakage and corrosion. Printed-circuit coatings are often used to ensure that moisture cannot corrode the leads or circuit traces.

The junction temperature of the LMT01 is the actual temperature being measured by the device. The thermal resistance junction-to-ambient ( $R_{\theta JA}$ ) is the parameter (from [Thermal Information](#)) used to calculate the rise of a device junction temperature (self-heating) due to its average power dissipation. The average power dissipation of the LMT01 is dependent on the temperature it is transmitting as it effects the output pulse count and the voltage across the device. [Equation 4](#) is used to calculate the self-heating in the die temperature of the LMT01 ( $T_{SH}$ ).

$$T_{SH} = \left[ I_{OL} \times \frac{t_{CONV}}{(t_{CONV} + t_{DATA})} \times V_{CONV} \right] + \left[ \left( \frac{PC}{4096} \times \frac{(I_{OL} + I_{OH})}{2} \right) + \left( \frac{(4096 - PC)}{4096} \times I_{OL} \right) \right] \times \frac{t_{DATA}}{(t_{CONV} + t_{DATA})} \times V_{DATA} \times R_{\theta JA}$$

where

- $T_{SH}$  is the ambient temperature
- $I_{OL}$  and  $I_{OH}$  are the output low and high current level, respectively
- $V_{CONV}$  is the voltage across the LMT01 during conversion
- $V_{DATA}$  is the voltage across the LMT01 during data transmission
- $t_{CONV}$  is the conversion time
- $t_{DATA}$  is the data transmission time
- PC is the output pulse count
- $R_{\theta JA}$  is the junction to ambient package thermal resistance (4)

Plotted in the curve [Figure 27](#) are the typical average supply current (black line using left y axis) and the resulting self-heating (red and violet lines using right y axis) during continuous conversions. A temperature range of  $-50^{\circ}\text{C}$  to  $+150^{\circ}\text{C}$ , a  $V_{CONV}$  of 5 V (red line) and 2.15 V (violet line) were used for the self-heating calculation. As can be seen in the curve, the average power supply current and thus the average self-heating changes linearly over temperature because the number of pulses increases with temperature. A negligible self-heating of about  $45\text{m}^{\circ}\text{C}$  is observed at  $150^{\circ}\text{C}$  with continuous conversions. If temperature readings are not required as frequently as every 100 ms, self-heating can be minimized by shutting down power to the part periodically thus lowering the average power dissipation.

## Application Information (continued)

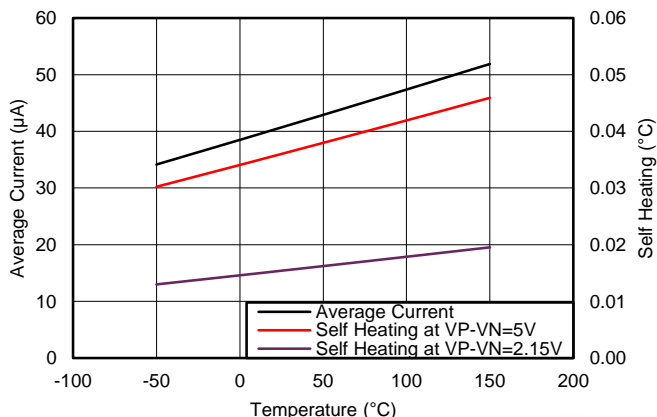

Figure 27. Average Current Draw and Self-Heating Over Temperature

## 8.2 Typical Application

### 8.2.1 3.3-V System VDD MSP430 Interface - Using Comparator Input

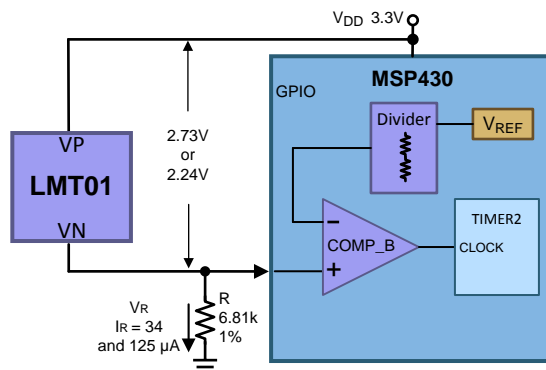

Figure 28. MSP430 Comparator Input Implementation

#### 8.2.1.1 Design Requirements

The design requirements listed in are used in the detailed design procedure.

Table 2. Design Parameters

DESIGN PARAMETER	EXAMPLE VALUE
VDD	3.3 V
VDD minimum	3.0 V
LMT01 VP – VN minimum during conversion	2.15 V
LMT01 VP – VN minimum during data transmission	2.0 V
Noise margin	50 mV minimum
Comparator input current over temperature range of interest	< 1 µA
Resistor tolerance	1%

### 8.2.1.2 Detailed Design Procedure

First, select the R and determine the maximum logic low voltage and the minimum logic high voltage while ensuring that when the LMT01 is converting, the minimum ( $V_P - V_N$ ) requirement of 2.15 V is met.

- Select R using minimum  $V_P - V_N$  during data transmission (2 V) and maximum output current of the LMT01 (143.75  $\mu\text{A}$ )
  - $R = (3.0 \text{ V} - 2 \text{ V}) / 143.75 \mu\text{A} = 6.993 \text{ k}$  the closest 1% resistor is 6.980 k
  - 6.993 k is the maximum resistance so if using 1% tolerance resistor the actual resistor value needs to be 1% less than 6.993 k and 6.98 k is 0.2% less than 6.993 k thus 6.81 k must be used.
- Check to see if the 2.15-V minimum voltage during conversion requirement for the LMT01 is met with the maximum  $I_{OL}$  of 39  $\mu\text{A}$  and maximum R of 6.81 k + 1%:
  - $V_{LMT01} = 3 \text{ V} - (6.81 \text{ k} \times 1.01) \times 39 \mu\text{A} = 2.73 \text{ V}$
- Find the maximum low level voltage range using the maximum R of 6.81 k and maximum  $I_{OL}$  of 39  $\mu\text{A}$ :
  - $V_{RLmax} = (6.81 \text{ k} \times 1.01) \times 39 \mu\text{A} = 268 \text{ mV}$
- Find the minimum high level voltage using the minimum R of 6.81 k and minimum  $I_{OH}$  of 112.5  $\mu\text{A}$ :
  - $V_{RHmin} = (6.81 \text{ k} \times 0.99) \times 112.5 \mu\text{A} = 758 \text{ mV}$

Now select the MSP430 comparator threshold voltage that enables the LMT01 to communicate to the MSP430 properly.

- The MSP430 voltage is selected by selecting the internal  $V_{REF}$  and then choosing the appropriate 1 of n/32 settings for n of 1 to 31.
  - $V_{MID} = (V_{RLmax} - V_{RHmin}) / 2 + V_{RHmin} = (758 \text{ mV} - 268 \text{ mV}) / 2 + 268 \text{ mV} = 513 \text{ mV}$
  - $n = (V_{MID} / V_{REF}) \times 32 = (0.513 / 2.5) \times 32 = 7$
- To prevent oscillation of the comparator, output hysteresis must be implemented. The MSP430 allows this by enabling different n for the rising edge and falling edge of the comparator output. For a falling comparator output transition, N must be set to 6.
- Determine the noise margin caused by variation in comparator threshold level. Even though the comparator threshold level theoretically is set to  $V_{MID}$ , the actual level varies from device to device due to  $V_{REF}$  tolerance, resistor divider tolerance, and comparator offset. For proper operation, the COMP\_B worst case input threshold levels must be within the minimum high and maximum low voltage levels presented across R,  $V_{RHmin}$  and  $V_{RLmax}$ , respectively

$$V_{CHmax} = V_{REF} \times (1 + V_{REF\_TOL}) \times \frac{(N + N\_TOL)}{32} + COMP\_OFFSET$$

where

- $V_{REF}$  is the MSP430 COMP\_B reference voltage for this example at 2.5 V
  - $V_{REF\_TOL}$  is the tolerance of the  $V_{REF}$  of 1% or 0.01,
  - N is the divisor for the MSP430 or 7
  - $N\_TOL$  is the tolerance of the divisor or 0.5
  - $COMP\_OFFSET$  is the comparator offset specification or 10 mV
- (5)

$$V_{CLmin} = V_{REF} \times (1 - V_{REF\_TOL}) \times \frac{(N - N\_TOL)}{32} - COMP\_OFFSET$$

where

- $V_{REF}$  is the MSP430 COMP\_B reference voltage for this example at 2.5 V,
  - $V_{REF\_TOL}$  is the tolerance of the  $V_{REF}$  of 1% or 0.01,
  - N is the divisor for the MSP430 for the hysteresis setting or 6,
  - $N\_TOL$  is the tolerance of the divisor or 0.5,
  - $COMP\_OFFSET$  is the comparator offset specification or 10 mV
- (6)

The noise margin is the minimum of the two differences:

$$(V_{RHmin} - V_{CHmax}) \text{ or } (V_{CHmin} - V_{RLmax})$$
(7)

which works out to be 145 mV.

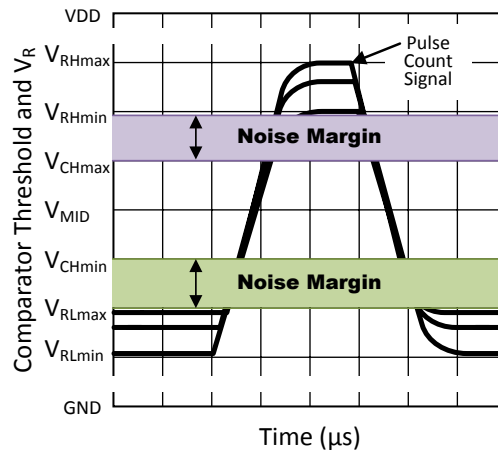
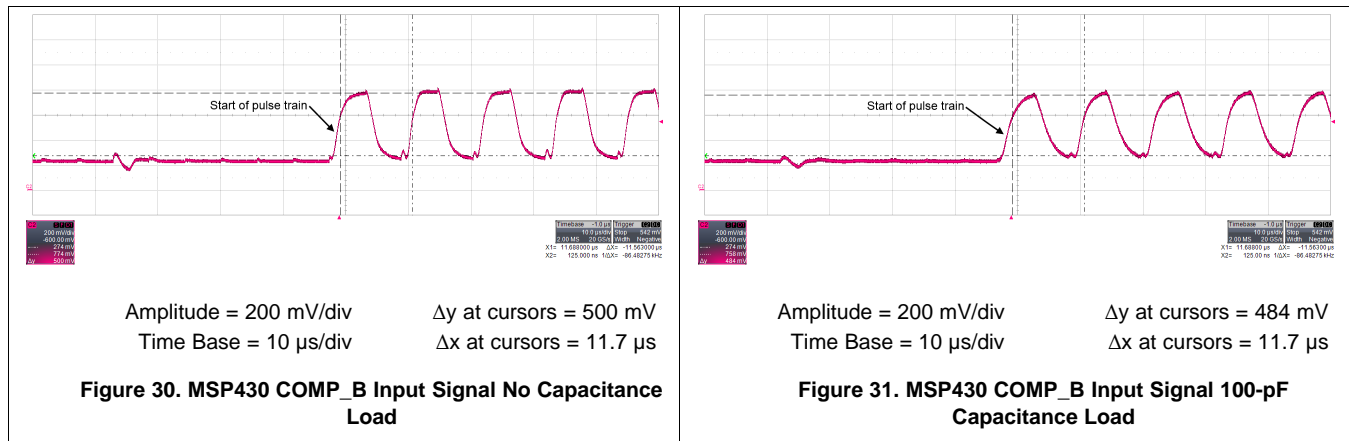

Figure 29. Pulse Count Signal Amplitude Variation

### 8.2.1.2.1 Setting the MSP430 Threshold and Hysteresis

The comparator hysteresis determines the noise level that the signal can support without causing the comparator to trip falsely and resulting in an inaccurate pulse count. The comparator hysteresis is set by the precision of the MSP430 and what thresholds it is capable of. For this case, as the input signal transitions high, the comparator threshold is dropped by 77 mV. If the noise on the signal is kept below this level as it transitions, the comparator will not trip falsely. In addition, the MSP430 has a digital filter on the COMP\_B output that be used to further filter output transitions that occur too quickly.

### 8.2.1.3 Application Curves



## 8.3 System Examples

The LMT01 device can be configured in a number of ways. Transistor level shifting can be used so that the output pulse of the device can be read with a GPIO (see Figure 32). An isolation block can be inserted to achieve electrical isolation (see Figure 33). Multiple LMT01 devices can be controlled with GPIOs enabling temperature monitor for multiple zones. Lastly, the LMT01 device can be configured to have a common ground with a high side signal (see Figure 35).

System Examples (continued)

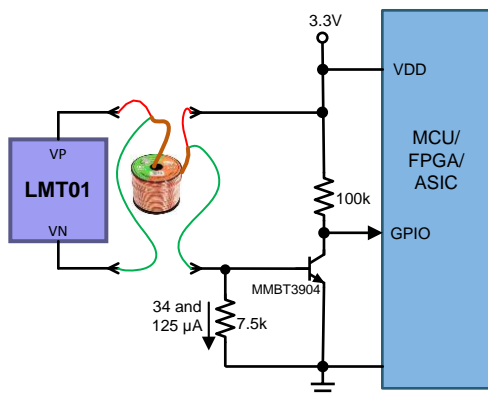

Figure 32. Transistor Level Shifting

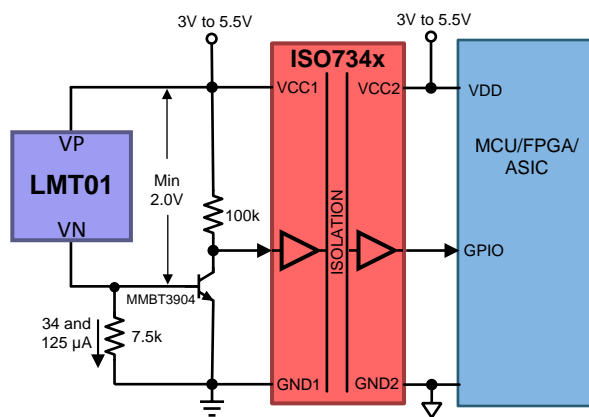
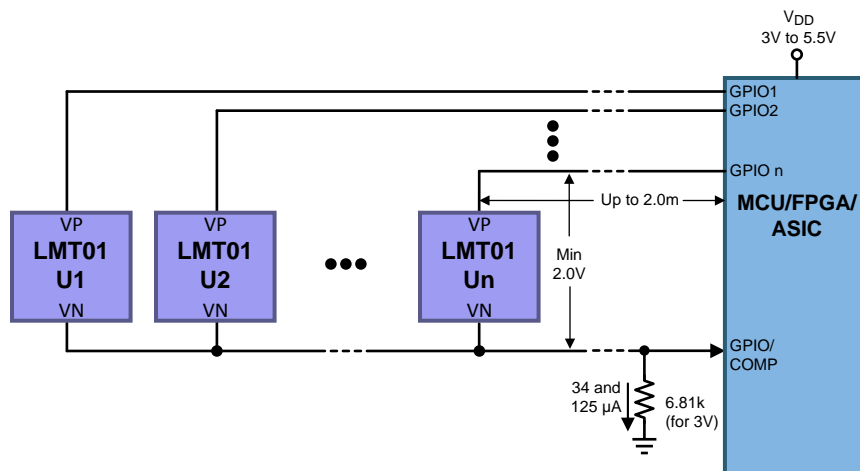

Figure 33. Isolation



Note: to turn off an LMT01 set the GPIO pin connected to VP to high impedance state as setting it low would cause the off LMT01 to be reverse biased. Comparator input of MCU must be used.

Figure 34. Connecting Multiple Devices to One MCU Input Pin

System Examples (continued)

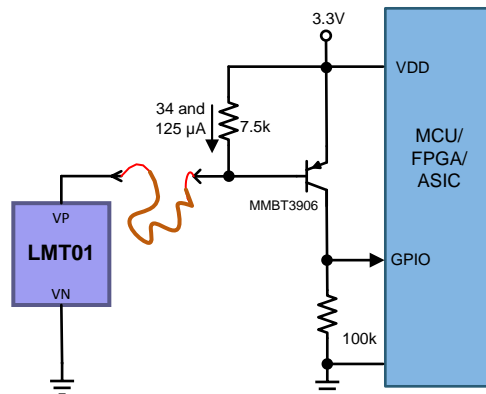

Note: the VN of the LMT01 must be connected to the MCU GND.

Figure 35. Common Ground With High-Side Signal

9 Power Supply Recommendations

Because the LMT01 is only a 2-pin device the power pins are common with the signal pins, thus the LMT01 has a floating supply that can vary greatly. The LMT01 has an internal regulator that provides a stable voltage to internal circuitry.

Take care to prevent reverse biasing of the LMT01 as exceeding the absolute maximum ratings may cause damage to the device.

Power supply ramp rate can effect the accuracy of the first result transmitted by the LMT01. As shown in Figure 36 with a 1-ms rise time, the LMT01 output code is at 1286, which converts to 30.125°C. The scope photo shown in Figure 37 reflects what happens when the rise time is too slow. In Figure 37, the power supply (yellow trace) is still ramping up to final value while the LMT01 (red trace) has already started a conversion. This causes the output pulse count to decrease from the previously shown 1286, to 1282 (or 29.875°C). Thus, for slow ramp rates, TI recommends that the first conversion be discarded. For even slower ramp rates, more than one conversion may have to be discarded as TI recommends that either the power supply be within final value before a conversion is used or that ramp rates be faster than 2.5 ms.

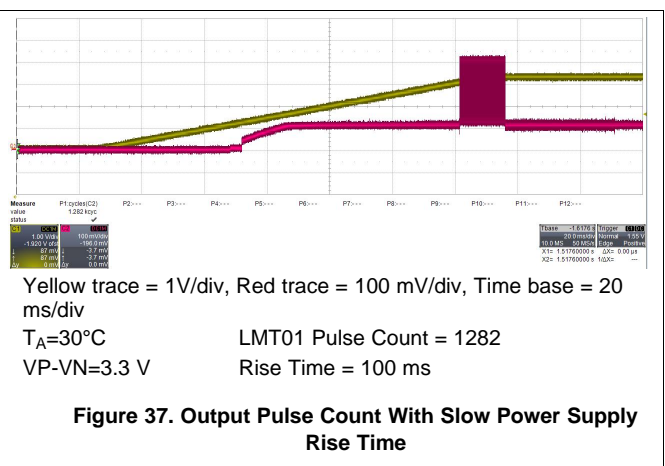
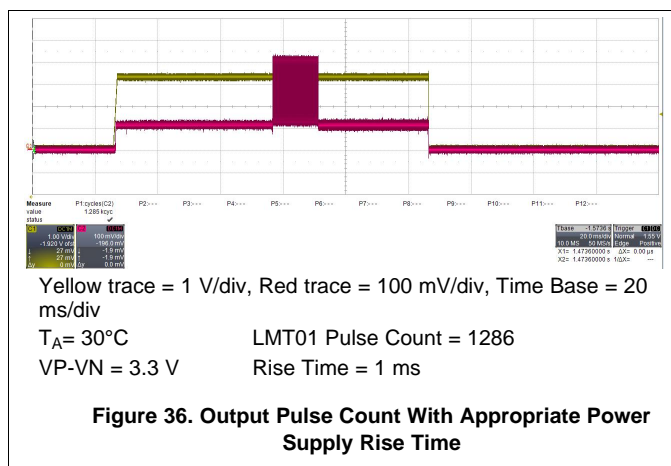

## 10 Layout

### 10.1 Layout Guidelines

The LMT01 can be mounted to a PCB as shown in [Figure 38](#) and [Figure 39](#). Take care to make the traces leading to the pads as small as possible to minimize their effect on the temperature the LMT01 is measuring.

### 10.2 Layout Example

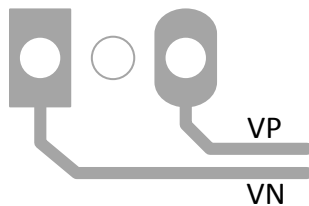

Figure 38. Layout Example (TO92S/LPG Package)

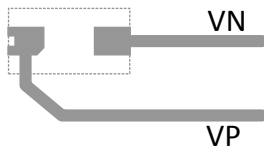

Figure 39. Layout Example for the DQX (WSON) Package

## 11 器件和文档支持

### 11.1 接收文档更新通知

要接收文档更新通知，请导航至 [TI.com.cn](http://TI.com.cn) 上的器件产品文件夹。单击右上角的 [通知我](#) 进行注册，即可每周接收产品信息更改摘要。有关更改的详细信息，请查看任何已修订文档中包含的修订历史记录。

### 11.2 社区资源

下列链接提供到 TI 社区资源的连接。链接的内容由各个分销商“按照原样”提供。这些内容并不构成 TI 技术规范，并且不一定反映 TI 的观点；请参阅 TI 的 [《使用条款》](#)。

**TI E2E™ 在线社区** [TI 的工程师对工程师 \(E2E\) 社区](#)。此社区的创建目的在于促进工程师之间的协作。在 [e2e.ti.com](http://e2e.ti.com) 中，您可以咨询问题、分享知识、拓展思路并与同行工程师一道帮助解决问题。

**设计支持** [TI 参考设计支持](#) 可帮助您快速查找有帮助的 E2E 论坛、设计支持工具以及技术支持的联系信息。

### 11.3 商标

E2E is a trademark of Texas Instruments.  
All other trademarks are the property of their respective owners.

### 11.4 静电放电警告



ESD 可能会损坏该集成电路。德州仪器 (TI) 建议通过适当的预防措施处理所有集成电路。如果不遵守正确的处理措施和安装程序，可能会损坏集成电路。

ESD 的损坏小至导致微小的性能降级，大至整个器件故障。精密的集成电路可能更容易受到损坏，这是因为非常细微的参数更改都可能会导致器件与其发布的规格不相符。

### 11.5 术语表

[SLYZ022](#) — *TI 术语表*。

这份术语表列出并解释术语、缩写和定义。

## 12 机械、封装和可订购信息

以下页面包含机械、封装和可订购信息。这些信息是指定器件的最新可用数据。数据如有变更，恕不另行通知，且不会对此文档进行修订。如需获取此数据表的浏览器版本，请参阅左侧的导航栏。



**PACKAGING INFORMATION**

Orderable Device	Status (1)	Package Type	Package Drawing	Pins	Package Qty	Eco Plan (2)	Lead finish/ Ball material (6)	MSL Peak Temp (3)	Op Temp (°C)	Device Marking (4/5)	Samples
LMT01DQXR	ACTIVE	WSON	DQX	2	3000	RoHS & Green	SN	Level-1-260C-UNLIM	-50 to 150	13N	<a href="#">Samples</a>
LMT01DQXT	OBSOLETE	WSON	DQX	2		TBD	Call TI	Call TI	-50 to 150	13N	
LMT01LPG	ACTIVE	TO-92	LPG	2	1000	RoHS & Green	SN	N / A for Pkg Type	-50 to 150	LMT01	<a href="#">Samples</a>
LMT01LPGM	ACTIVE	TO-92	LPG	2	3000	RoHS & Green	SN	N / A for Pkg Type	-50 to 150	LMT01	<a href="#">Samples</a>

(1) The marketing status values are defined as follows:

**ACTIVE:** Product device recommended for new designs.

**LIFEBUY:** TI has announced that the device will be discontinued, and a lifetime-buy period is in effect.

**NRND:** Not recommended for new designs. Device is in production to support existing customers, but TI does not recommend using this part in a new design.

**PREVIEW:** Device has been announced but is not in production. Samples may or may not be available.

**OBSOLETE:** TI has discontinued the production of the device.

(2) **RoHS:** TI defines "RoHS" to mean semiconductor products that are compliant with the current EU RoHS requirements for all 10 RoHS substances, including the requirement that RoHS substance do not exceed 0.1% by weight in homogeneous materials. Where designed to be soldered at high temperatures, "RoHS" products are suitable for use in specified lead-free processes. TI may reference these types of products as "Pb-Free".

**RoHS Exempt:** TI defines "RoHS Exempt" to mean products that contain lead but are compliant with EU RoHS pursuant to a specific EU RoHS exemption.

**Green:** TI defines "Green" to mean the content of Chlorine (Cl) and Bromine (Br) based flame retardants meet JS709B low halogen requirements of <=1000ppm threshold. Antimony trioxide based flame retardants must also meet the <=1000ppm threshold requirement.

(3) MSL, Peak Temp. - The Moisture Sensitivity Level rating according to the JEDEC industry standard classifications, and peak solder temperature.

(4) There may be additional marking, which relates to the logo, the lot trace code information, or the environmental category on the device.

(5) Multiple Device Markings will be inside parentheses. Only one Device Marking contained in parentheses and separated by a "~" will appear on a device. If a line is indented then it is a continuation of the previous line and the two combined represent the entire Device Marking for that device.

(6) Lead finish/Ball material - Orderable Devices may have multiple material finish options. Finish options are separated by a vertical ruled line. Lead finish/Ball material values may wrap to two lines if the finish value exceeds the maximum column width.

**Important Information and Disclaimer:**The information provided on this page represents TI's knowledge and belief as of the date that it is provided. TI bases its knowledge and belief on information provided by third parties, and makes no representation or warranty as to the accuracy of such information. Efforts are underway to better integrate information from third parties. TI has taken and continues to take reasonable steps to provide representative and accurate information but may not have conducted destructive testing or chemical analysis on incoming materials and chemicals. TI and TI suppliers consider certain information to be proprietary, and thus CAS numbers and other limited information may not be available for release.

In no event shall TI's liability arising out of such information exceed the total purchase price of the TI part(s) at issue in this document sold by TI to Customer on an annual basis.

**OTHER QUALIFIED VERSIONS OF LMT01 :**

- Automotive : [LMT01-Q1](#)

**NOTE: Qualified Version Definitions:**

- Automotive - Q100 devices qualified for high-reliability automotive applications targeting zero defects

**TAPE AND REEL INFORMATION**

**QUADRANT ASSIGNMENTS FOR PIN 1 ORIENTATION IN TAPE**

\*All dimensions are nominal

Device	Package Type	Package Drawing	Pins	SPQ	Reel Diameter (mm)	Reel Width W1 (mm)	A0 (mm)	B0 (mm)	K0 (mm)	P1 (mm)	W (mm)	Pin1 Quadrant
LMT01DQXR	WSO	DQX	2	3000	180.0	8.4	2.0	2.8	1.0	4.0	8.0	Q1

**TAPE AND REEL BOX DIMENSIONS**

\*All dimensions are nominal

Device	Package Type	Package Drawing	Pins	SPQ	Length (mm)	Width (mm)	Height (mm)
LMT01DQXR	WSON	DQX	2	3000	200.0	183.0	25.0

# LPG0002A



# PACKAGE OUTLINE

## TO-92 - 5.05 mm max height

TRANSISTOR OUTLINE

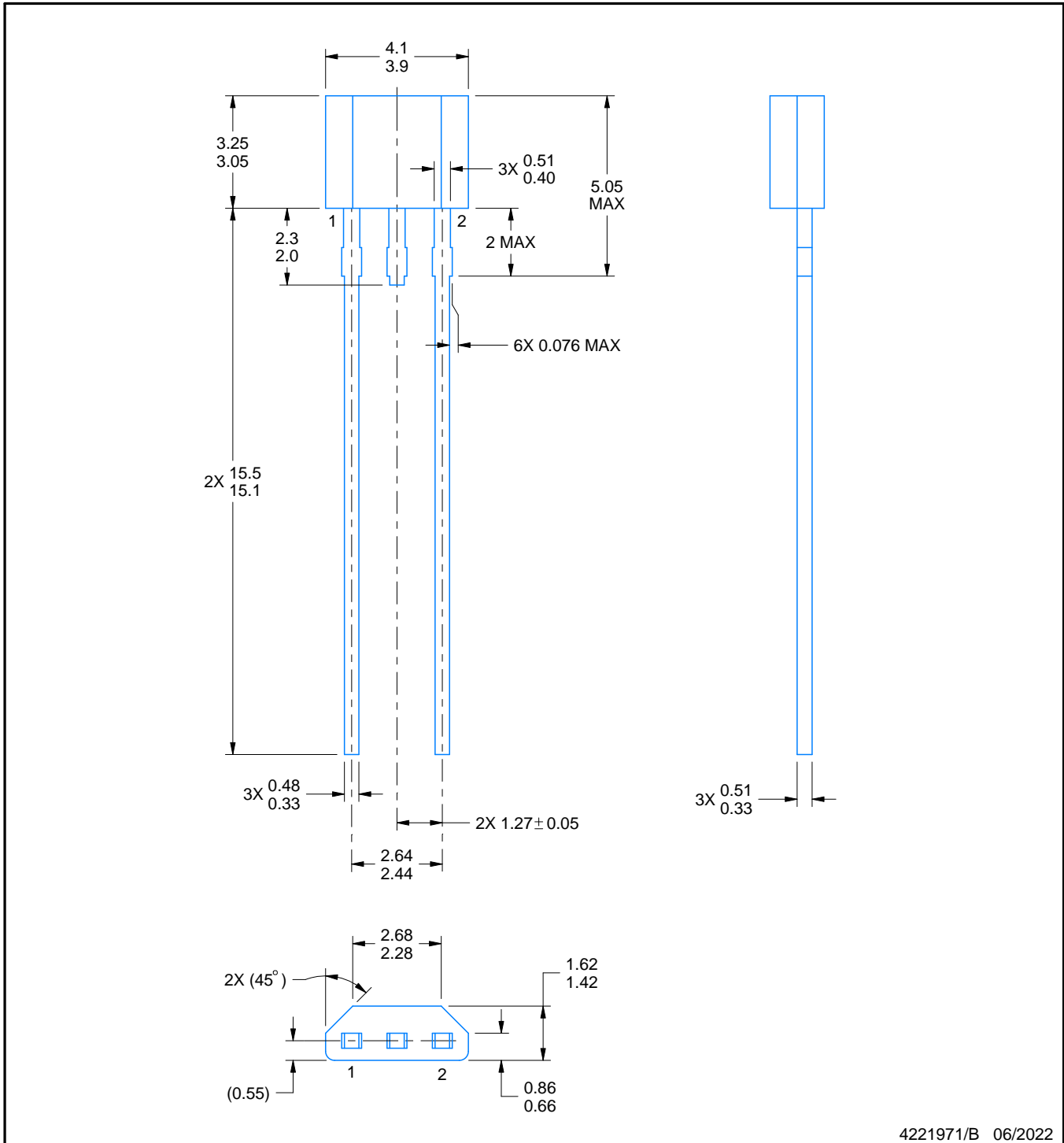

4221971/B 06/2022

### NOTES:

1. All linear dimensions are in millimeters. Any dimensions in parenthesis are for reference only. Dimensioning and tolerancing per ASME Y14.5M.
2. This drawing is subject to change without notice.

# EXAMPLE BOARD LAYOUT

LPG0002A

TO-92 - 5.05 mm max height

TRANSISTOR OUTLINE

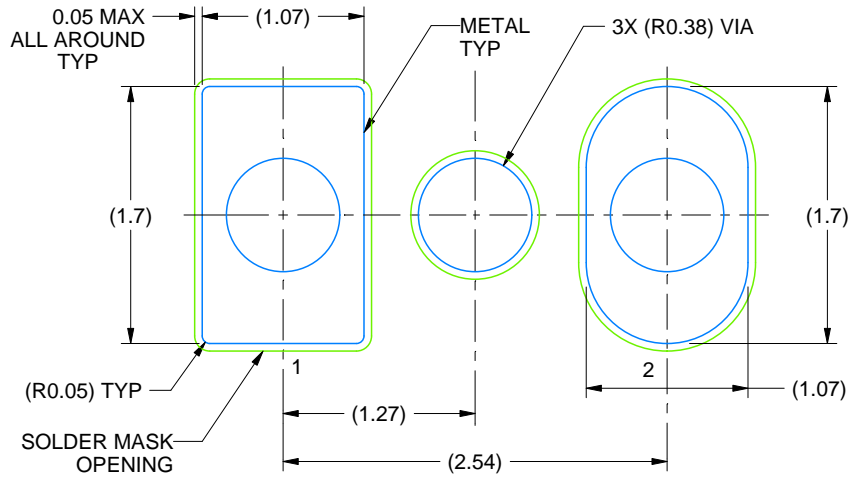

LAND PATTERN EXAMPLE  
NON-SOLDER MASK DEFINED  
SCALE:20X

4221971/B 06/2022

# TAPE SPECIFICATIONS

LPG0002A

TO-92 - 5.05 mm max height

TRANSISTOR OUTLINE

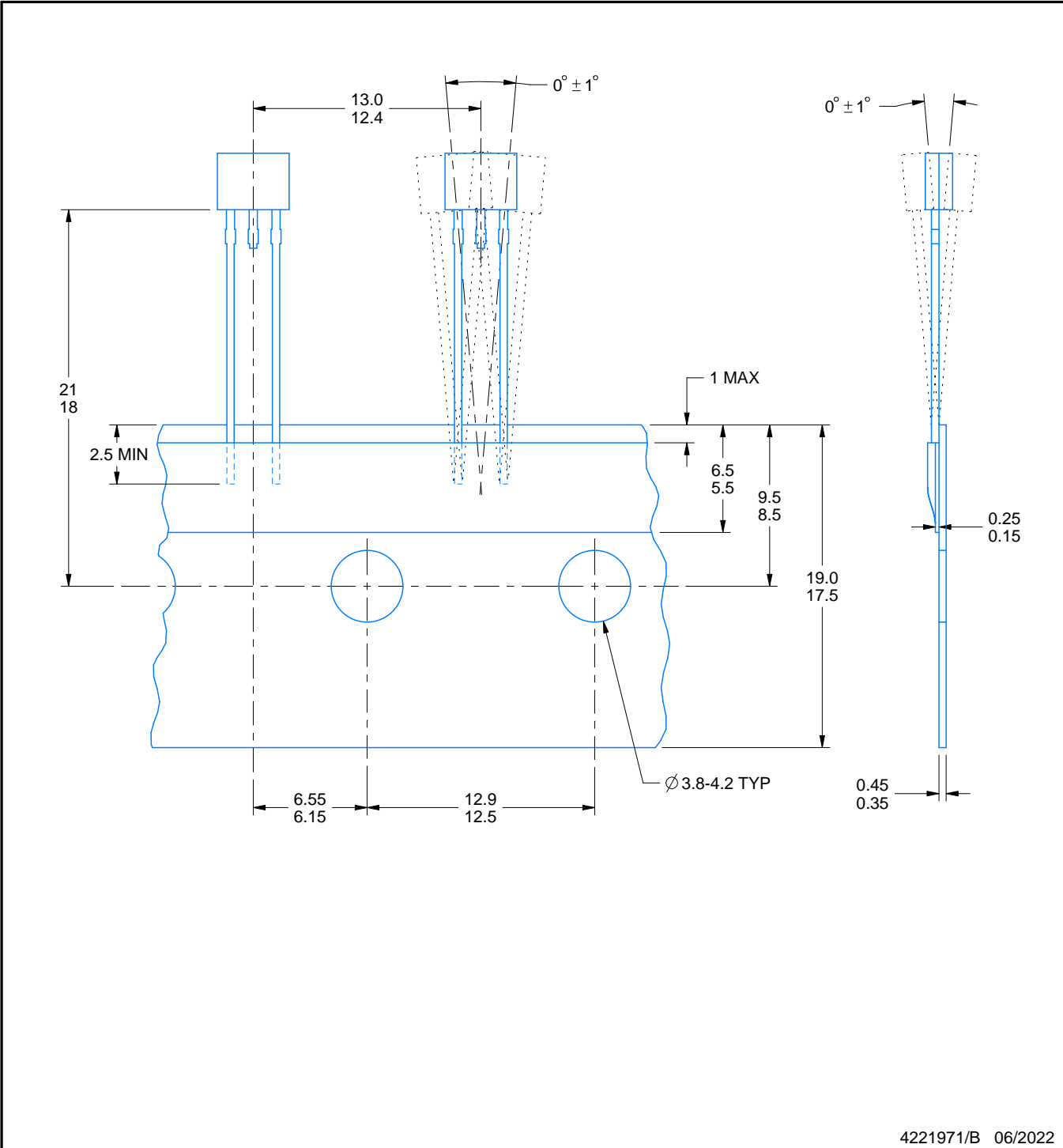

## GENERIC PACKAGE VIEW

**DQX 2**

**WSO - 0.8 mm max height**

1.7 x 2.5, 0 mm pitch

PLASTIC SMALL OUTLINE - NO LEAD

This image is a representation of the package family, actual package may vary.  
Refer to the product data sheet for package details.



4225319/A



DQX0002A



PACKAGE OUTLINE

WSO - 0.8 mm max height

PLASTIC SMALL OUTLINE - NO LEAD

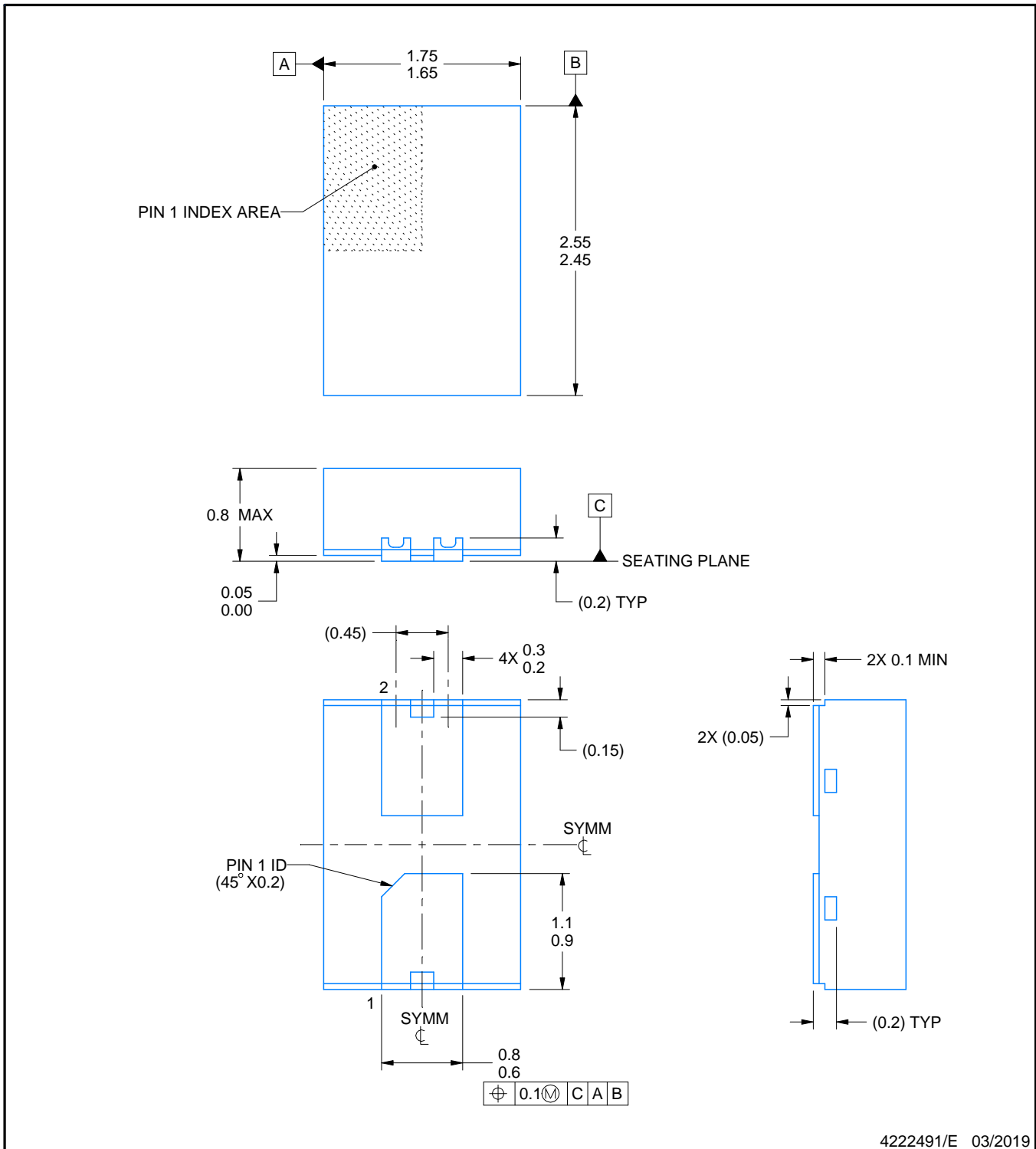

4222491/E 03/2019

NOTES:

1. All linear dimensions are in millimeters. Any dimensions in parenthesis are for reference only. Dimensioning and tolerancing per ASME Y14.5M
2. This drawing is subject to change without notice.

# EXAMPLE BOARD LAYOUT

DQX0002A

WSON - 0.8 mm max height

PLASTIC SMALL OUTLINE - NO LEAD

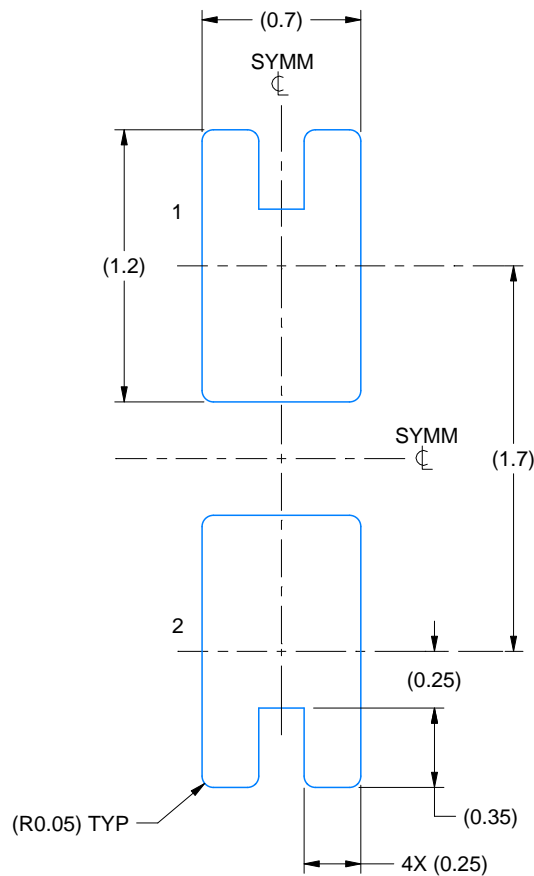

LAND PATTERN EXAMPLE  
EXPOSED METAL SHOWN  
SCALE:30X

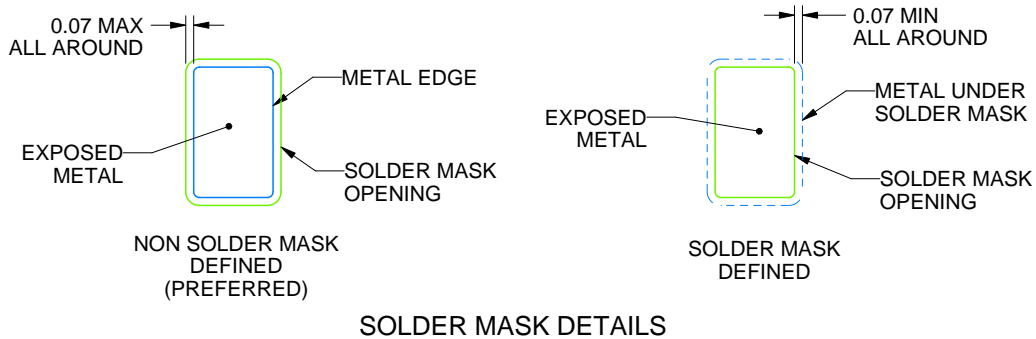

4222491/E 03/2019

NOTES: (continued)

3. For more information, see Texas Instruments literature number SLUA271 ([www.ti.com/lit/sluea271](http://www.ti.com/lit/sluea271)).
4. Vias are optional depending on application, refer to device data sheet. If any vias are implemented, refer to their locations shown on this view. It is recommended that vias under paste be filled, plugged or tented.

# EXAMPLE STENCIL DESIGN

DQX0002A

WSON - 0.8 mm max height

PLASTIC SMALL OUTLINE - NO LEAD

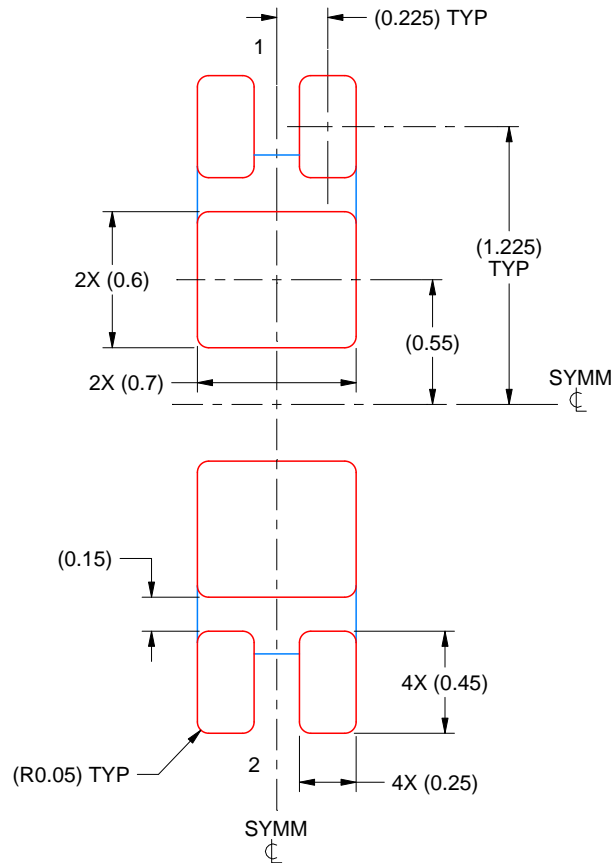

SOLDER PASTE EXAMPLE  
BASED ON 0.1 mm THICK STENCIL

81% PRINTED SOLDER COVERAGE BY AREA UNDER PACKAGE  
SCALE:30X

4222491/E 03/2019

NOTES: (continued)

5. Laser cutting apertures with trapezoidal walls and rounded corners may offer better paste release. IPC-7525 may have alternate design recommendations.

## 重要声明和免责声明

TI“按原样”提供技术和可靠性数据（包括数据表）、设计资源（包括参考设计）、应用或其他设计建议、网络工具、安全信息和其他资源，不保证没有瑕疵且不做任何明示或暗示的担保，包括但不限于对适销性、某特定用途方面的适用性或不侵犯任何第三方知识产权的暗示担保。

这些资源可供使用 TI 产品进行设计的熟练开发人员使用。您将自行承担以下全部责任：(1) 针对您的应用选择合适的 TI 产品，(2) 设计、验证并测试您的应用，(3) 确保您的应用满足相应标准以及任何其他功能安全、信息安全、监管或其他要求。

这些资源如有变更，恕不另行通知。TI 授权您仅可将这些资源用于研发本资源所述的 TI 产品的应用。严禁对这些资源进行其他复制或展示。您无权使用任何其他 TI 知识产权或任何第三方知识产权。您应全额赔偿因在这些资源的使用中对 TI 及其代表造成的任何索赔、损害、成本、损失和债务，TI 对此概不负责。

TI 提供的产品受 [TI 的销售条款](#) 或 [ti.com](#) 上其他适用条款/TI 产品随附的其他适用条款的约束。TI 提供这些资源并不会扩展或以其他方式更改 TI 针对 TI 产品发布的适用的担保或担保免责声明。

TI 反对并拒绝您可能提出的任何其他或不同的条款。

邮寄地址：Texas Instruments, Post Office Box 655303, Dallas, Texas 75265  
Copyright © 2024，德州仪器 (TI) 公司