

PCM1794A 24 位、192kHz 采样、高级分段、音频立体声数模转换器

1 特性

- 24 位分辨率
- 模拟性能：
 - 动态范围：
 - 132dB (9V RMS, 单声道)
 - 129dB (4.5V RMS, 立体声)
 - 127dB (2V RMS, 立体声)
 - 总谐波失真 + 噪声 (THD+N): 0.0004%
- 差分电流输出: 7.8mA p-p
- 8x 过采样数字滤波器：
 - 阻带衰减: -130dB
 - 通带纹波: ± 0.00001 dB
- 采样频率: 10kHz 至 200kHz
- 系统时钟: 128、192、256、384、512 或 768 f_s , 带自动检测功能
- 接受 16 位和 24 位音频数据
- 脉冲编码调制 (PCM) 数据格式: 标准、I²S 和左对齐
- 可供外部数字滤波器或数字信号处理器 (DSP) 选用的接口
- 数字去加重功能
- 数字滤波器衰减: 急剧或缓慢
- 软静音
- 零标记
- 双电源支持: 5V 模拟、3.3V 数字
- 5V 耐压数字输入
- 小型 28 引脚紧缩小外形 (SSOP) 封装

2 应用

- A/V 接收器
- DVD 播放器
- 乐器
- 车载音频系统
- 其他需要 24 位音频的应用

3 说明

PCM1794A 器件是一款单片 CMOS 集成电路, 由立体声数模转换器 (DAC) 和采用小型 28 引脚 SSOP 封装的支持电路组成。数据转换器采用德州仪器 (TI) 的高级分段 DAC 架构, 拥有出色的动态性能和增强的时钟抖动耐受性。PCM1794A 器件提供均衡电流输出, 允许用户从外部优化模拟性能。最高支持 200kHz 的采样速率。

器件信息⁽¹⁾

器件型号	封装	封装尺寸 (标称值)
PCM1794A	SSOP (28)	10.20mm x 5.30mm

(1) 要了解所有可用封装, 请见数据表末尾的可订购产品附录。

简化的应用示意图

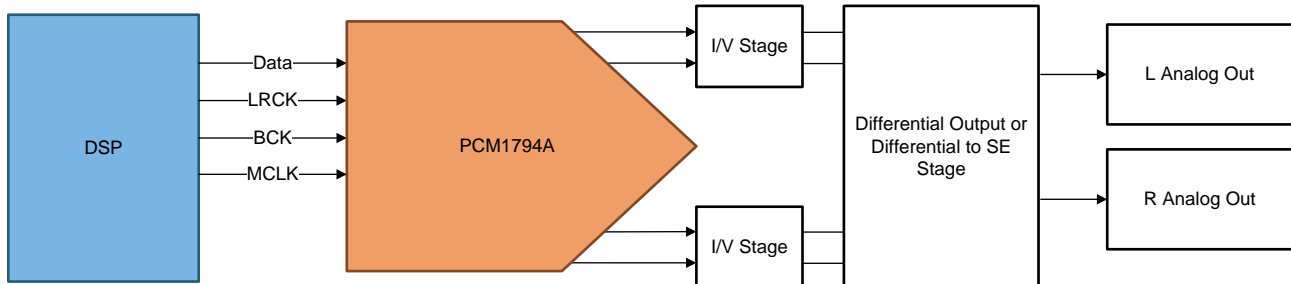

目录

<ul style="list-style-type: none"> 1 特性 1 2 应用 1 3 说明 1 4 修订历史记录 2 5 Pin Configuration and Functions 3 6 Specifications 4 <ul style="list-style-type: none"> 6.1 Absolute Maximum Ratings 4 6.2 ESD Ratings 4 6.3 Recommended Operating Conditions 5 6.4 Thermal Information 5 6.5 Electrical Characteristics 5 6.6 Timing Requirements 7 6.7 Typical Characteristics 9 7 Detailed Description 12 <ul style="list-style-type: none"> 7.1 Overview 12 7.2 Functional Block Diagram 12 	<ul style="list-style-type: none"> 7.3 Feature Description 13 7.4 Device Functional Modes 18 8 Application and Implementation 19 <ul style="list-style-type: none"> 8.1 Application Information 19 8.2 Typical Application 25 9 Power Supply Recommendations 26 10 Layout 26 <ul style="list-style-type: none"> 10.1 Layout Guidelines 26 10.2 Layout Example 27 11 器件和文档支持 28 <ul style="list-style-type: none"> 11.1 文档支持 28 11.2 社区资源 28 11.3 商标 28 11.4 静电放电警告 28 11.5 Glossary 28 12 机械、封装和可订购信息 28
---	--

4 修订历史记录

注：之前版本的页码可能与当前版本有所不同。

Changes from Revision A (November 2006) to Revision B

Page

- | | |
|---|---|
| <ul style="list-style-type: none"> • 已添加 <i>ESD</i> 额定值表，特性描述部分，器件功能模式，应用和实施部分，电源相关建议部分，布局部分，器件和文档支持部分以及机械、封装和可订购信息部分。 | 1 |
|---|---|

5 Pin Configuration and Functions

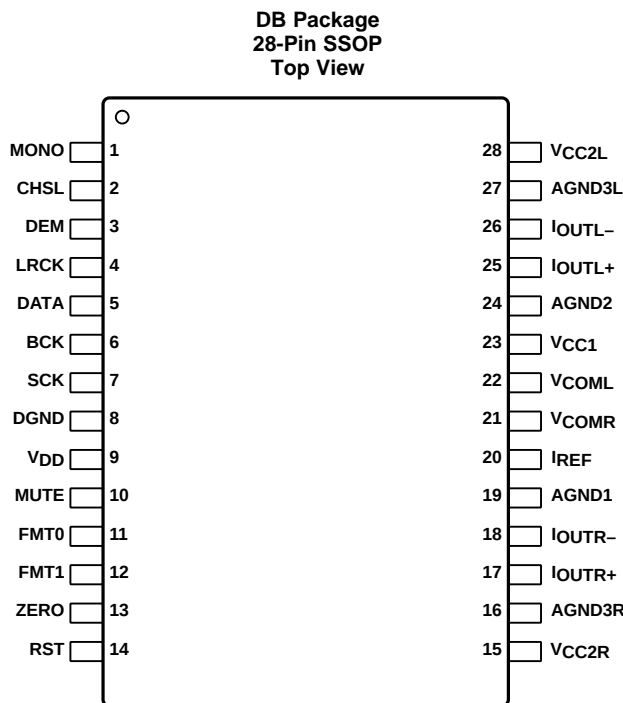

Pin Functions

PIN		I/O	DESCRIPTION
NO.	NAME		
1	MONO	I	Monaural mode enable ⁽¹⁾
2	CHSL	I	L-channel, R-channel select ⁽¹⁾
3	DEM	I	De-emphasis enable ⁽¹⁾
4	LRCK	I	Left and right clock (f_S) input ⁽¹⁾
5	DATA	I	Serial audio data input ⁽¹⁾
6	BCK	I	Bit clock input ⁽¹⁾
7	SCK	I	System clock input ⁽¹⁾
8	DGND	—	Digital ground
9	V _{DD}	—	Digital power supply, 3.3 V
10	MUTE	I	Mute control ⁽¹⁾
11	FMT0	I	Audio data format select ⁽¹⁾
12	FMT1	I	Audio data format select ⁽¹⁾
13	ZERO	O	Zero flag
14	$\overline{\text{RST}}$	I	Reset ⁽¹⁾
15	V _{CC2R}	—	Analog power supply (R-channel DAC), 5 V
16	AGND3R	—	Analog ground (R-channel DAC)
17	I _{OUTR+}	O	R-channel analog current output +
18	I _{OUTR-}	O	R-channel analog current output –
19	AGND1	—	Analog ground (internal bias)
20	I _{REF}	—	Output current reference bias pin
21	V _{COMR}	—	R-channel internal bias decoupling pin
22	V _{COML}	—	L-channel internal bias decoupling pin

(1) Schmitt-trigger input, 5-V tolerant.

Pin Functions (continued)

PIN		I/O	DESCRIPTION
NO.	NAME		
23	V _{CC1}	—	Analog power supply, 5 V
24	AGND2	—	Analog ground (internal bias)
25	I _{OUTL+}	O	L-channel analog current output +
26	I _{OUTL-}	O	L-channel analog current output –
27	AGND3L	—	Analog ground (L-channel DAC)
28	V _{CC2L}	—	Analog power supply (L-channel DAC), 5 V

6 Specifications

6.1 Absolute Maximum Ratings

over operating free-air temperature range (unless otherwise noted) ⁽¹⁾

		MIN	MAX	UNIT
Supply Voltage	V _{CC1} , V _{CC2L} , V _{CC2R}	–0.3	6.5	V
	V _{DD}	–0.3	4	
Supply voltage differences: V _{CC1} , V _{CC2L} , V _{CC2R}			±0.1	V
Ground voltage differences: AGND1, AGND2, AGND3L, AGND3R, DGND			±0.1	V
Digital input voltage	LRCK, DATA, BCK, SCK, FMT1, FMT0, MONO, CHSL, DEM, MUTE, RST	–0.3	6.5	V
	ZERO	–0.3	(V _{DD} + 0.3 V) < 4	
Analog input voltage		–0.3	(V _{CC} + 0.3 V) < 6.5	V
Input current (any pins except supplies)			±10	mA
Ambient temperature under bias		–40	125	°C
Junction temperature			150	°C
Lead temperature (soldering, 5 s)			260	°C
Package temperature (IR reflow, peak)			250	°C
Storage temperature, T _{stg}		–55	150	°C

(1) Stresses beyond those listed under *Absolute Maximum Ratings* may cause permanent damage to the device. These are stress ratings only, which do not imply functional operation of the device at these or any other conditions beyond those indicated under *Recommended Operating Conditions*. Exposure to absolute-maximum-rated conditions for extended periods may affect device reliability.

6.2 ESD Ratings

		VALUE	UNIT
V _(ESD) Electrostatic discharge	Human-body model (HBM), per ANSI/ESDA/JEDEC JS-001 ⁽¹⁾	±2500	V
	Charged-device model (CDM), per JEDEC specification JESD22-C101 ⁽²⁾	±1500	

(1) JEDEC document JEP155 states that 500-V HBM allows safe manufacturing with a standard ESD control process.

(2) JEDEC document JEP157 states that 250-V CDM allows safe manufacturing with a standard ESD control process.

6.3 Recommended Operating Conditions

over operating free-air temperature range (unless otherwise noted)

		MIN	NOM	MAX	UNIT
Supply voltage	V _{DD}	3	3.3	3.6	VDC
	V _{CC1} V _{CC2L} V _{CC2R}	4.75	5	5.25	VDC
	T _J Operation temperature	–25		85	°C

6.4 Thermal Information

THERMAL METRIC ⁽¹⁾		PCM1794A	UNIT
		DB (SSOP)	
		28 PINS	
R _{θJA}	Junction-to-ambient thermal resistance	66.4	°C/W
R _{θJC(top)}	Junction-to-case (top) thermal resistance	25.4	°C/W
R _{θJB}	Junction-to-board thermal resistance	27.5	°C/W
Ψ _{JT}	Junction-to-top characterization parameter	2.3	°C/W
Ψ _{JB}	Junction-to-board characterization parameter	27.1	°C/W
R _{θJC(bot)}	Junction-to-case (bottom) thermal resistance	—	°C/W

(1) For more information about traditional and new thermal metrics, see the *Semiconductor and IC Package Thermal Metrics* application report, [SPRA953](#).

6.5 Electrical Characteristics

all specifications at T_A = 25°C, V_{CC1} = V_{CC2L} = V_{CC2R} = 5 V, V_{DD} = 3.3 V, f_S = 44.1 kHz, system clock = 256 f_S, and 24-bit data, unless otherwise noted

PARAMETER	TEST CONDITIONS	MIN	TYP	MAX	UNIT
DATA FORMAT					
f _S Sampling frequency		10		200	kHz
System clock frequency		128, 192, 256, 384, 512, 768			f _S
DIGITAL INPUT/OUTPUT					
Logic family		TTL compatible			
V _{IH} Input logic level high		2			VDC
V _{IL} Input logic level low				0.8	VDC
I _{IH} Input logic current high	V _{IN} = V _{DD}			10	μA
I _{IL} Input logic current low	V _{IN} = 0 V			–10	μA
V _{OH} Output logic level high	I _{OH} = –2 mA	2.4			VDC
V _{OL} Output logic level low	I _{OL} = 2 mA			0.4	VDC
DYNAMIC PERFORMANCE (2-V RMS OUTPUT)⁽¹⁾⁽²⁾					
THD+N at V _{OUT} = 0 dB	f _S = 44.1 kHz		0.0004%	0.0008%	
	f _S = 96 kHz		0.0008%		
	f _S = 192 kHz		0.0015%		
Dynamic range	EIAJ, A-weighted, f _S = 44.1 kHz	123	127		dB
	EIAJ, A-weighted, f _S = 96 kHz		127		
	EIAJ, A-weighted, f _S = 192 kHz		127		

(1) Filter condition:

(a) THD+N: 20-Hz HPF, 20-kHz apogee LPF

(b) Dynamic range: 20-Hz HPF, 20-kHz AES17 LPF, A-weighted

(c) Signal-to-noise ratio: 20-Hz HPF, 20-kHz AES17 LPF, A-weighted

(d) Channel separation: 20-Hz HPF, 20-kHz AES17 LPF

(e) Analog performance specifications are measured using the System Two Cascade audio measurement system by Audio Precision™ in the averaging mode.

(2) Dynamic performance and dc accuracy are specified at the output of the postamplifier as shown in [Figure 25](#).

Electrical Characteristics (continued)

all specifications at $T_A = 25^\circ\text{C}$, $V_{CC1} = V_{CC2L} = V_{CC2R} = 5\text{ V}$, $V_{DD} = 3.3\text{ V}$, $f_S = 44.1\text{ kHz}$, system clock = $256 f_S$, and 24-bit data, unless otherwise noted

PARAMETER	TEST CONDITIONS	MIN	TYP	MAX	UNIT
Signal-to-noise ratio	EIAJ, A-weighted, $f_S = 44.1\text{ kHz}$	123	127		dB
	EIAJ, A-weighted, $f_S = 96\text{ kHz}$		127		
	EIAJ, A-weighted, $f_S = 192\text{ kHz}$		127		
Channel separation	$f_S = 44.1\text{ kHz}$	120	123		dB
	$f_S = 96\text{ kHz}$		122		
	$f_S = 192\text{ kHz}$		120		
Level linearity error	$V_{OUT} = -120\text{ dB}$		± 1		dB
DYNAMIC PERFORMANCE (4.5-V RMS Output)⁽¹⁾⁽³⁾					
THD+N at $V_{OUT} = 0\text{ dB}$	$f_S = 44.1\text{ kHz}$		0.0004%		
	$f_S = 96\text{ kHz}$		0.0008%		
	$f_S = 192\text{ kHz}$		0.0015%		
Dynamic range	EIAJ, A-weighted, $f_S = 44.1\text{ kHz}$		129		dB
	EIAJ, A-weighted, $f_S = 96\text{ kHz}$		129		
	EIAJ, A-weighted, $f_S = 192\text{ kHz}$		129		
Signal-to-noise ratio	EIAJ, A-weighted, $f_S = 44.1\text{ kHz}$		129		dB
	EIAJ, A-weighted, $f_S = 96\text{ kHz}$		129		
	EIAJ, A-weighted, $f_S = 192\text{ kHz}$		129		
Channel separation	$f_S = 44.1\text{ kHz}$		124		dB
	$f_S = 96\text{ kHz}$		123		
	$f_S = 192\text{ kHz}$		121		
DYNAMIC PERFORMANCE (MONO MODE)⁽¹⁾⁽³⁾					
THD+N at $V_{OUT} = 0\text{ dB}$	$f_S = 44.1\text{ kHz}$		0.0004%		
	$f_S = 96\text{ kHz}$		0.0008%		
	$f_S = 192\text{ kHz}$		0.0015%		
Dynamic range	EIAJ, A-weighted, $f_S = 44.1\text{ kHz}$		132		dB
	EIAJ, A-weighted, $f_S = 96\text{ kHz}$		132		
	EIAJ, A-weighted, $f_S = 192\text{ kHz}$		132		
Signal-to-noise ratio	EIAJ, A-weighted, $f_S = 44.1\text{ kHz}$		132		dB
	EIAJ, A-weighted, $f_S = 96\text{ kHz}$		132		
	EIAJ, A-weighted, $f_S = 192\text{ kHz}$		132		
ANALOG OUTPUT					
Gain error		-6	± 2	6	% of FSR
Gain mismatch, channel-to-channel		-3	± 0.5	3	% of FSR
Bipolar zero error	At BPZ	-2	± 0.5	2	% of FSR
Output current	Full scale (0 dB)		7.8		mA p-p
Center current	At BPZ		-6.2		mA
DIGITAL FILTER PERFORMANCE					
De-emphasis error				± 0.004	dB
FILTER CHARACTERISTICS-1: SHARP ROLLOFF					
Pass band	$\pm 0.00001\text{ dB}$			$0.454 f_S$	
	-3 dB			$0.49 f_S$	
Stop band		$0.546 f_S$			
Pass-band ripple				± 0.00001	dB
Stop-band attenuation	Stop band = $0.546 f_S$	-130			dB
Delay time			$55/f_S$		s
FILTER CHARACTERISTICS-2: SLOW ROLLOFF					
Pass band	$\pm 0.04\text{ dB}$			$0.254 f_S$	
	-3 dB			$0.46 f_S$	

(3) Dynamic performance and dc accuracy are specified at the output of the postamplifier as shown in Figure 26.

Electrical Characteristics (continued)

all specifications at $T_A = 25^\circ\text{C}$, $V_{CC1} = V_{CC2L} = V_{CC2R} = 5\text{ V}$, $V_{DD} = 3.3\text{ V}$, $f_S = 44.1\text{ kHz}$, system clock = $256 f_S$, and 24-bit data, unless otherwise noted

PARAMETER		TEST CONDITIONS	MIN	TYP	MAX	UNIT
Stop band			0.732 f_S			
Pass-band ripple					± 0.001	dB
Stop-band attenuation		Stop band = 0.732 f_S	-100			dB
Delay time				18 / f_S		s
POWER SUPPLY REQUIREMENTS						
I_{DD}	Digital supply current ⁽⁴⁾	$f_S = 44.1\text{ kHz}$		12	15	mA
		$f_S = 96\text{ kHz}$		23		
		$f_S = 192\text{ kHz}$		45		
I_{CC}	Analog supply current ⁽⁴⁾	$f_S = 44.1\text{ kHz}$		33	40	mA
		$f_S = 96\text{ kHz}$		35		
		$f_S = 192\text{ kHz}$		37		
Power dissipation ⁽⁴⁾		$f_S = 44.1\text{ kHz}$		205	250	mW
		$f_S = 96\text{ kHz}$		250		
		$f_S = 192\text{ kHz}$		335		

(4) Input is BPZ data.

6.6 Timing Requirements

		MIN	MAX	UNIT
SYSTEM CLOCK INPUT TIMING (see Figure 1)				
$t_{(SCY)}$	System-clock pulse-cycle time	13		ns
$t_{(SCKH)}$	System-clock pulse duration, HIGH	$0.4 \times t_{(SCY)}$		ns
$t_{(SCKL)}$	System-clock pulse duration, LOW	$0.4 \times t_{(SCY)}$		ns
EXTERNAL RESET TIMING (see Figure 2)				
$t_{(RST)}$	Reset pulse duration, LOW	20		ns
AUDIO INTERFACE TIMING (see Figure 3)				
$t_{(BCY)}$	BCK pulse-cycle time	70		ns
$t_{(BCL)}$	BCK pulse duration, LOW	30		ns
$t_{(BCH)}$	BCK pulse duration, HIGH	30		ns
$t_{(BL)}$	BCK rising edge to LRCK edge	10		ns
$t_{(LB)}$	LRCK edge to BCK rising edge	10		ns
$t_{(DS)}$	DATA setup time	10		ns
$t_{(DH)}$	DATA hold time	10		ns
	LRCK clock duty	50% \pm 2-bit clocks		

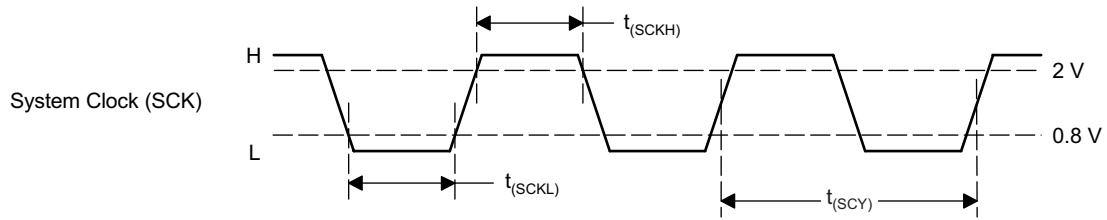

Figure 1. System Clock Input Timing

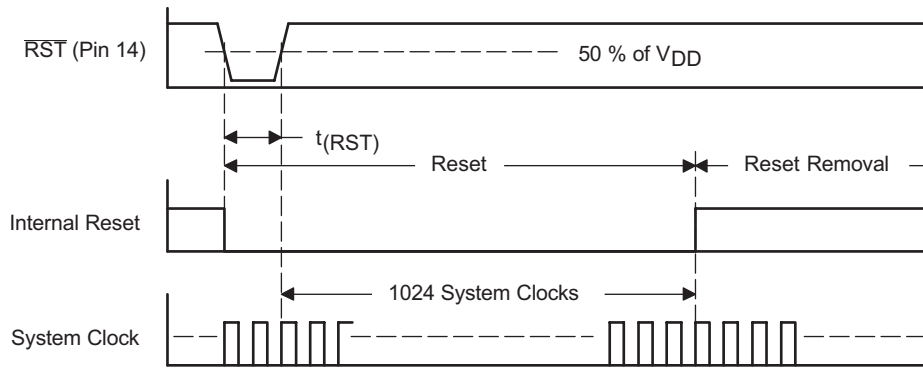

Figure 2. External Reset Timing

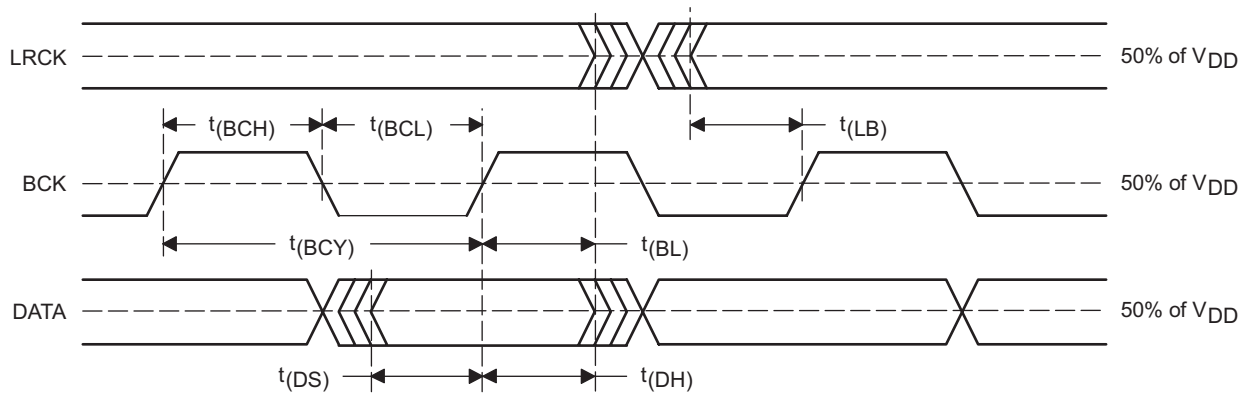

Figure 3. Timing of Audio Interface

6.7 Typical Characteristics

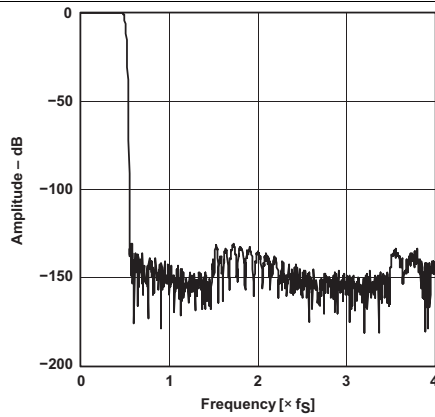

Figure 4. Amplitude vs Frequency Frequency Response, Sharp Rolloff

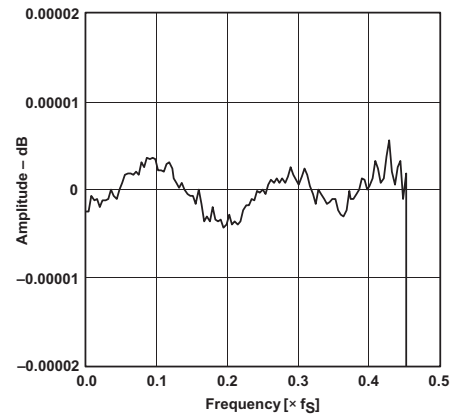

Figure 5. Amplitude vs Frequency Pass-Band Ripple, Sharp Rolloff

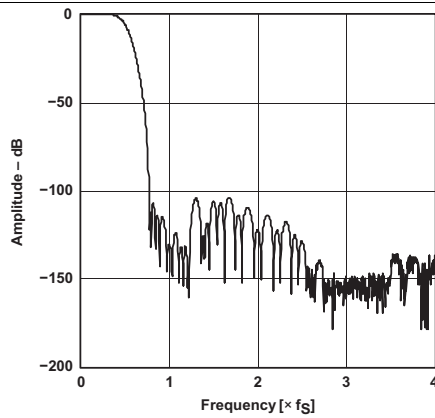

Figure 6. Amplitude vs Frequency Frequency Response, Slow Rolloff

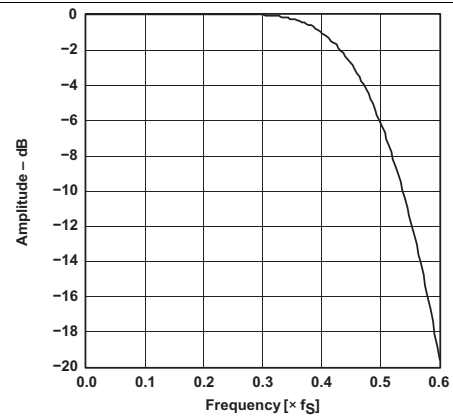

Figure 7. Amplitude vs Frequency Transition Characteristics, Slow Rolloff

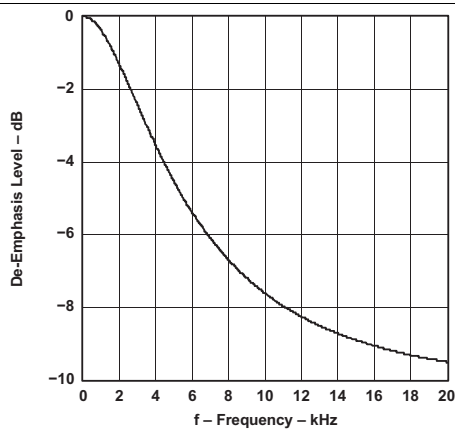

Figure 8. De-Emphasis Level vs Frequency

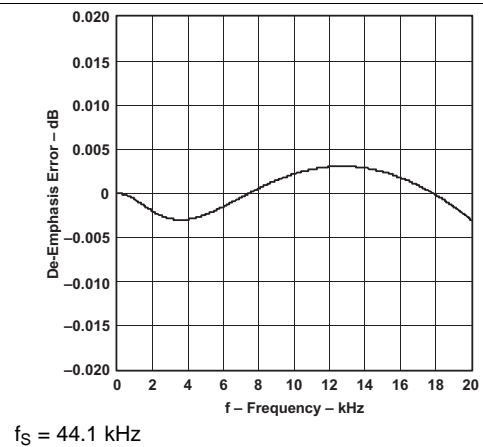

Figure 9. De-Emphasis Error vs Frequency

Typical Characteristics (continued)

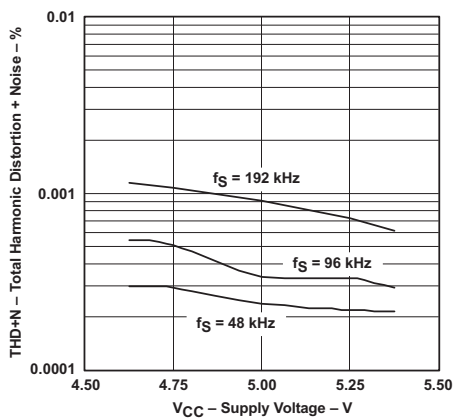

Figure 10. Total Harmonic Distortion + Noise vs Supply Voltage

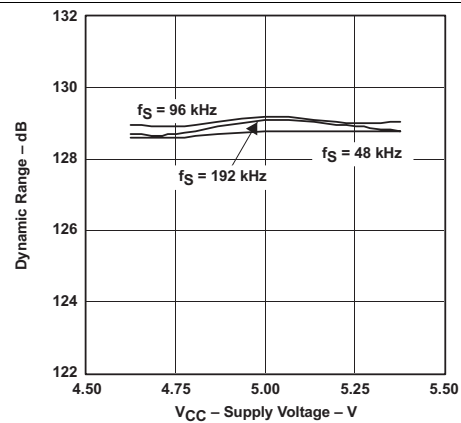
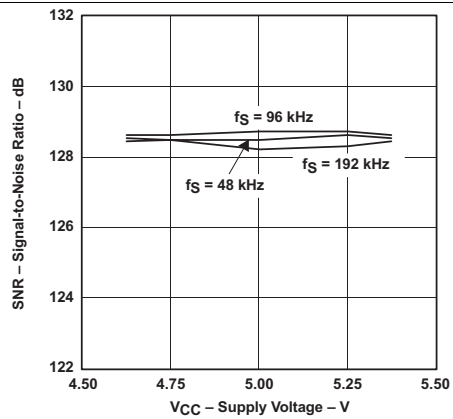

Figure 11. Dynamic Range vs Supply Voltage



$T_A = 25^\circ\text{C}$ $V_{OUT} = 4.5\text{ V}_{RMS}$
 $V_{DD} = 3.3\text{ V}$ Measurement circuit is [Figure 26](#)

Figure 12. Signal-to-Noise Ratio vs Supply Voltage

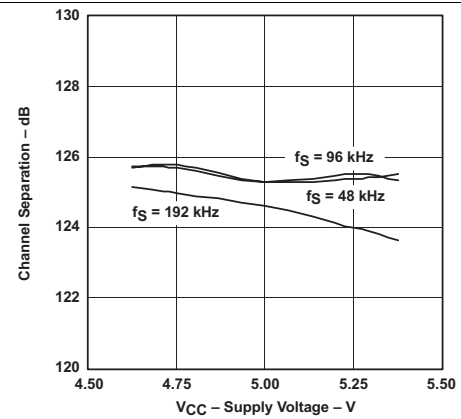

Figure 13. Channel Separation vs Supply Voltage

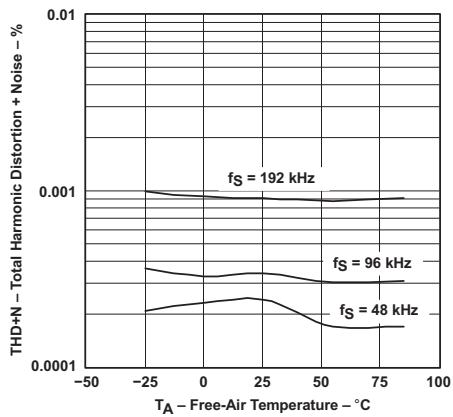

Figure 14. Total Harmonic Distortion + Noise vs Free-Air Temperature

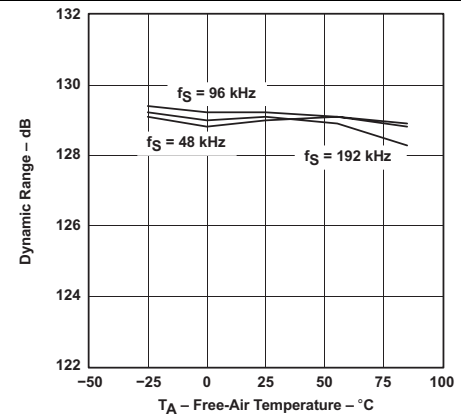
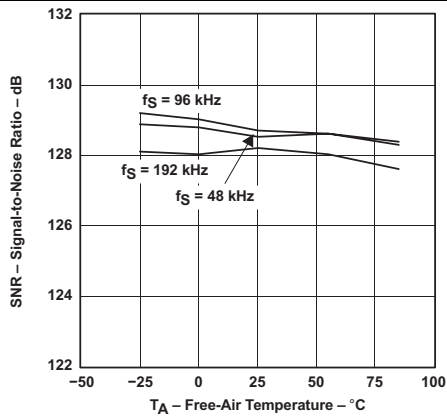

Figure 15. Dynamic Range vs Free-Air Temperature

Typical Characteristics (continued)



$V_{CC} = 5\text{ V}$ $V_{OUT} = 4.5\text{ V}_{RMS}$
 $V_{DD} = 3.3\text{ V}$ Measurement circuit is Figure 26.

Figure 16. Signal-to-Noise Ratio vs Free-Air Temperature

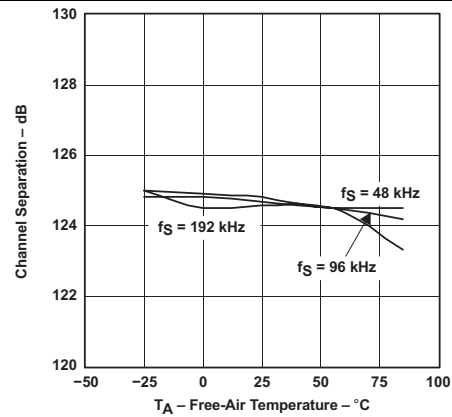
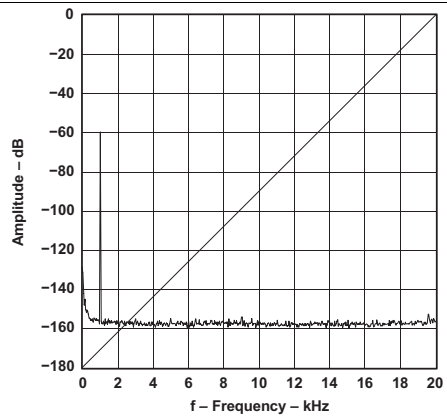
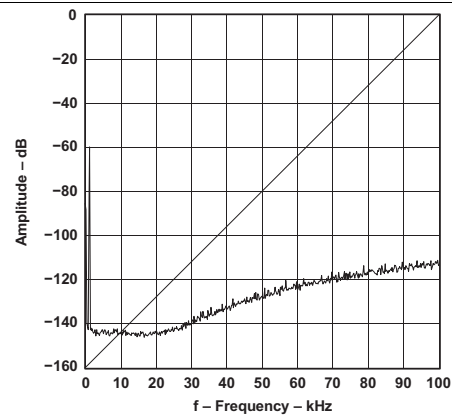

Figure 17. Channel Separation vs Free-Air Temperature



$V_{CC} = 5\text{ V}$ Measurement circuit is Figure 26
 $T_A = 25^\circ\text{C}$ $V_{DD} = 3.3\text{ V}$ $f_S = 48\text{ kHz}$, 32768 point 8 average

Figure 18. Amplitude vs Frequency
 -60-dB Output Spectrum, BW = 20 kHz



$V_{CC} = 5\text{ V}$ Measurement circuit is Figure 26
 $T_A = 25^\circ\text{C}$ $V_{DD} = 3.3\text{ V}$ $f_S = 48\text{ kHz}$, 32768 point 8 average

Figure 19. Amplitude vs Frequency
 -60-dB Output Spectrum, BW = 100 kHz

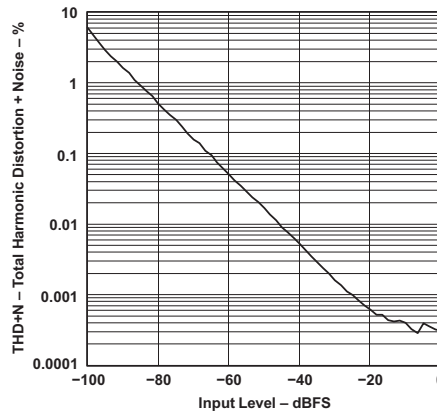

$V_{CC} = 5\text{ V}$ Measurement circuit is Figure 26
 $V_{DD} = 3.3\text{ V}$ $f_S = 48\text{ kHz}$, $T_A = 25^\circ\text{C}$

Figure 20. Total Harmonic Distortion + Noise vs Input Level

7 Detailed Description

7.1 Overview

The PCM1794A device is a 24-bit, 192-kHz, differential-current, output digital-to-analog converter (DAC) that comes in a 28-pin SSOP package. The PCM1794AA device is hardware controlled and uses the advanced-segment DAC architecture from TI to perform with a Stereo Dynamic Range of 129 dB (132 dB Mono) and with a THD of 0.0004% at 44.1 kHz. The PCM1794AA device uses the SCK input as the system clock and automatically detects the sampling rate of the Digital Audio input when valid BCK and LRCK clocks are supplied. To bypass the internal filter, use an external digital filter.

Table 1. Device Features

FEATURE	DESCRIPTION
Resolution	24 bits
Audio data interface format	Standard, I ² S, left justified
Audio data bit length	16-bit, 24-bit selectable
Audio data format	MSB first, two's complement

7.2 Functional Block Diagram

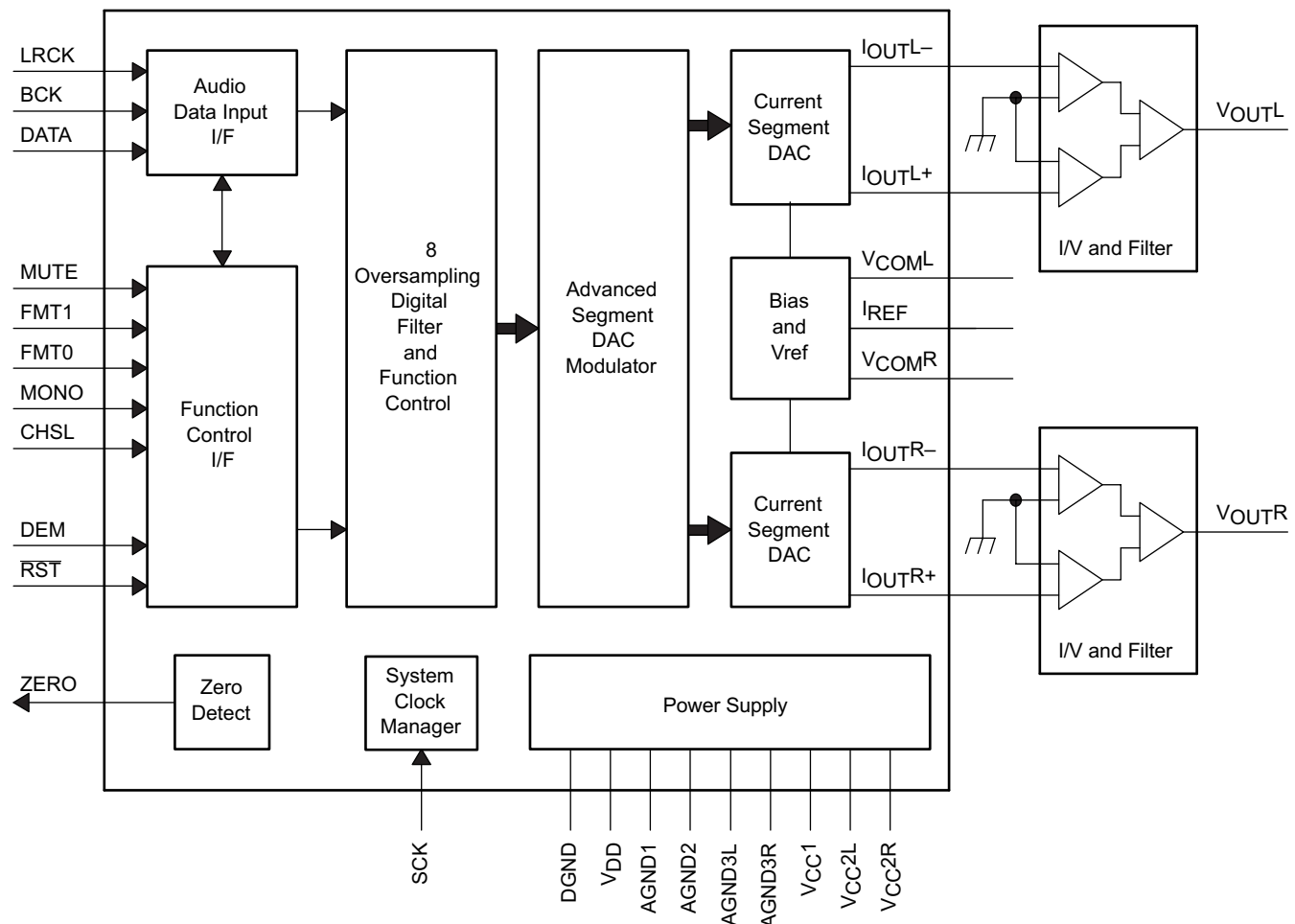

7.3 Feature Description

7.3.1 System Clock Input

The PCM1794A device requires a system clock for operating the digital interpolation filters and advanced segment DAC modulators. The system clock is applied at the SCK input (pin 7). The PCM1794A device has a system clock detection circuit that automatically senses the frequency at which the system clock is operating. Table 2 shows examples of system clock frequencies for common audio-sampling rates.

The *Timing Requirements* table lists and Figure 1 shows the timing requirements for the system clock input. For optimal performance, use a clock source with low-phase jitter and noise. One of the Texas Instruments PLL1700 family of multiclock generators is an excellent selection for providing the PCM1794A system clock.

Table 2. System Clock Rates for Common Audio Sampling Frequencies

SAMPLING FREQUENCY	SYSTEM CLOCK FREQUENCY (f _{SCK}) (MHz)					
	128 f _s	192 f _s	256 f _s	384 f _s	512 f _s	768 f _s
32 kHz	4.096	6.144	8.192	12.288	16.384	24.576
44.1 kHz	5.6488	8.4672	11.2896	16.9344	22.5792	33.8688
48 kHz	6.144	9.216	12.288	18.432	24.576	36.864
96 kHz	12.288	18.432	24.576	36.864	49.152	73.728
192 kHz	24.576	36.864	49.152	73.728	See ⁽¹⁾	See ⁽¹⁾

(1) This system clock rate is not supported for the given sampling frequency.

7.3.2 Power-On and External Reset Functions

The PCM1794A device includes a power-on reset function. Figure 21 shows the operation of this function. With V_{DD} > 2 V, the power-on reset function is enabled. The initialization sequence requires 1024 system clocks from the time V_{DD} > 2 V.

The PCM1794A device also includes an external reset capability using the $\overline{\text{RST}}$ input (pin 14), which allows an external controller or master reset circuit to force the PCM1794A device to initialize to its default reset state.

The *Timing Requirements* table lists and Figure 2 shows the external reset operation and timing. The $\overline{\text{RST}}$ pin is set to logic 0 for a minimum of 20 ns. The $\overline{\text{RST}}$ pin is then set to a logic 1 state to start the initialization sequence, which requires 1024 system clock periods. The external reset is useful in applications with a delay between the PCM1794A power-up and system clock activation.

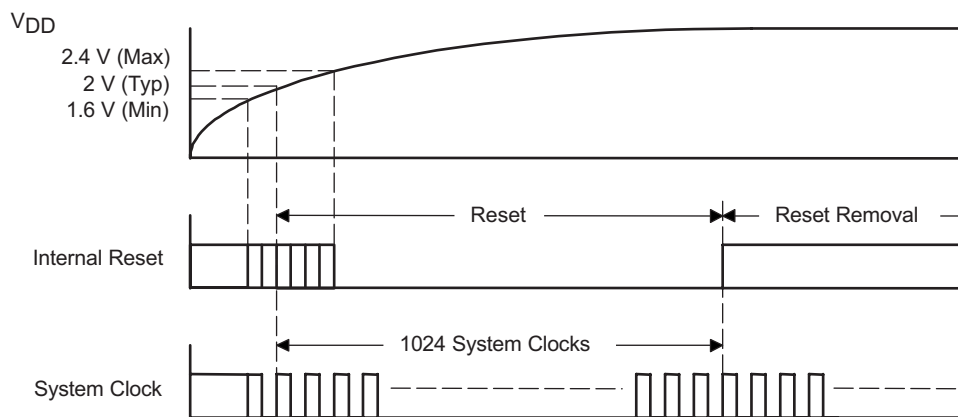

Figure 21. Power-On Reset Timing

7.3.3 Audio Data Interface

7.3.3.1 Audio Serial Interface

The audio interface port is a 3-wire serial port that includes LRCK (pin 4), BCK (pin 6), and DATA (pin 5). BCK is the serial audio bit clock, and used to clock the serial data present on DATA into the serial shift register of the audio interface. Serial data is clocked into the PCM1794A device on the rising edge of BCK. LRCK is the serial audio left/right word clock.

The PCM1794A device requires the synchronization of LRCK and the system clock, but does not require a specific phase relation between LRCK and the system clock.

If the relationship between LRCK and the system clock changes more than ± 6 BCK, internal operation is initialized within $1/f_S$, and the analog outputs are forced to the bipolar zero level until resynchronization between LRCK and the system clock is completed.

7.3.3.2 PCM Audio Data Formats and Timing

The PCM1794A device supports industry-standard audio data formats, including standard right-justified, I²S, and left-justified. The data formats are shown in [Figure 22](#). Data formats are selected using the format bits, FMT1 (pin 12), and FMT0 (pin 11) as shown in [Table 3](#). All formats require binary twos-complement, MSB-first audio data. The [Timing Requirements](#) table lists and [Figure 3](#) shows a detailed timing diagram for the serial audio interface.

(1) Standard Data Format (Right Justified); L-Channel = HIGH, R-Channel = LOW

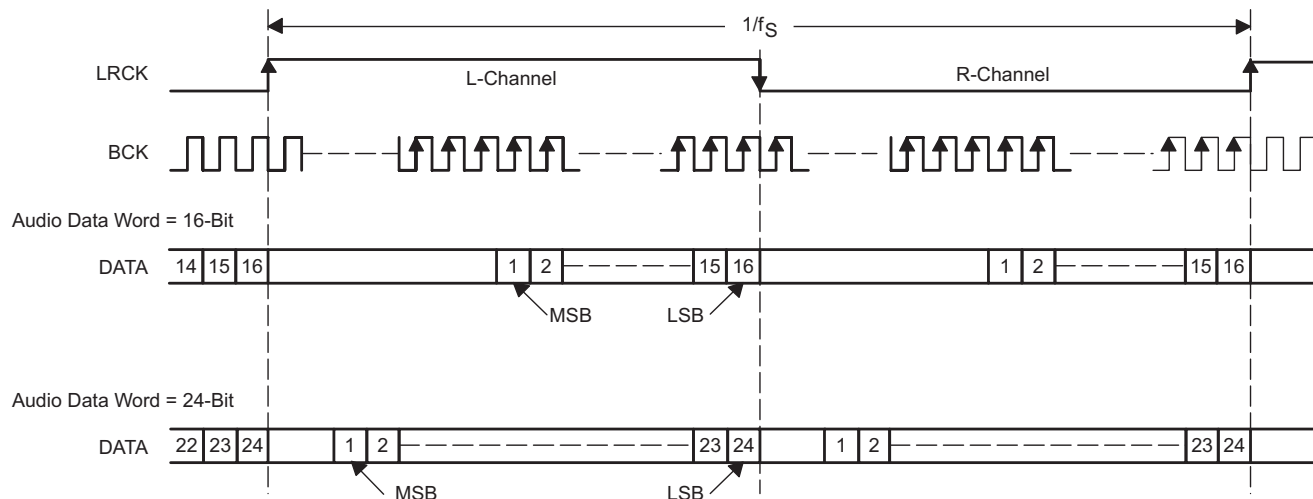

(2) Left Justified Data Format; L-Channel = HIGH, R-Channel = LOW

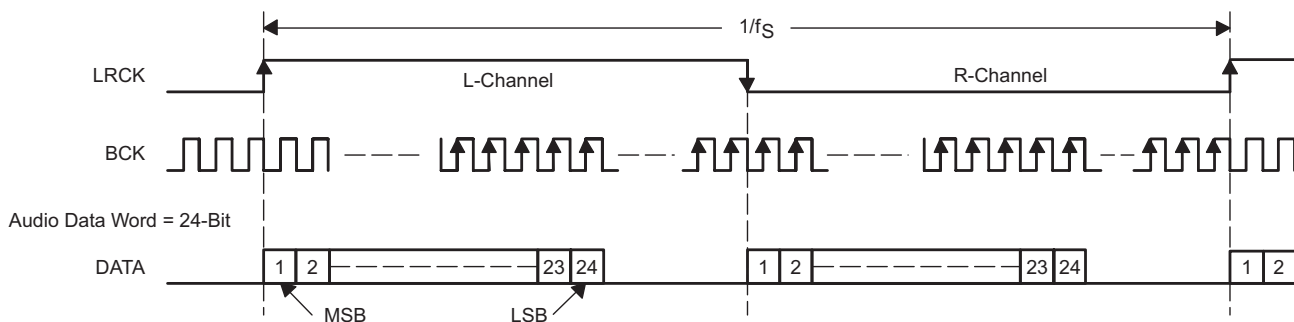

(3) I²S Data Format; L-Channel = LOW, R-Channel = HIGH

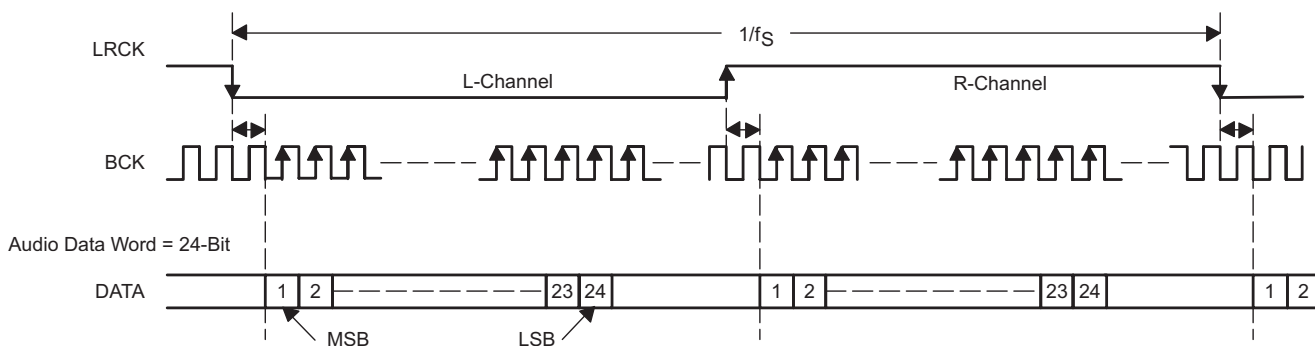

Figure 22. Audio Data Input Formats

7.3.4 Audio Data Format

Audio format is selected using FMT0 (pin 11) and FMT1 (pin 12). The PCM1794A device also supports monaural mode and DF bypass mode using MONO (pin 1) and CHSL (pin 2). The PCM1794A device can select the DF rolloff characteristics.

Table 3. Audio Data Format Select

MONO	CHSL	FMT1	FMT0	FORMAT	STEREO/MONO	DF ROLLOFF
0	0	0	0	I ² S	Stereo	Sharp
0	0	0	1	Left-justified format	Stereo	Sharp
0	0	1	0	Standard, 16-bit	Stereo	Sharp
0	0	1	1	Standard, 24-bit	Stereo	Sharp
0	1	0	0	I ² S	Stereo	Slow
0	1	0	1	Left-justified format	Stereo	Slow
0	1	1	0	Standard, 16-bit	Stereo	Slow
0	1	1	1	Digital filter bypass	Mono	—
1	0	0	0	I ² S	Mono, L-channel	Sharp
1	0	0	1	Left-justified format	Mono, L-channel	Sharp
1	0	1	0	Standard, 16-bit	Mono, L-channel	Sharp
1	0	1	1	Standard, 24-bit	Mono, L-channel	Sharp
1	1	0	0	I ² S	Mono, R-channel	Sharp
1	1	0	1	Left-justified format	Mono, R-channel	Sharp
1	1	1	0	Standard, 16-bit	Mono, R-channel	Sharp
1	1	1	1	Standard, 24-bit	Mono, R-channel	Sharp

7.3.5 Soft Mute

The PCM1794A device supports mute operation. When MUTE (pin 10) is set to HIGH, both analog outputs transition to the bipolar zero level in -0.5-dB steps with a transition speed of $1/f_s$ per step. The mute operation system provides pop-free muting of the DAC output.

7.3.6 De-Emphasis

The PCM1794A device has a de-emphasis filter for the sampling frequency of 44.1 kHz. The de-emphasis filter is controlled using DEM (pin 3).

7.3.7 Zero Detect

When the PCM1794A device detects that the audio input data in the L-channel and the R-channel is continuously zero for 1024 LRCKs in the PCM mode, or that the audio input data is continuously zero for 1024 WDCKs in the external filter mode, the PCM1794A device sets ZERO (pin 13) to HIGH.

7.3.8 Advanced Segment DAC

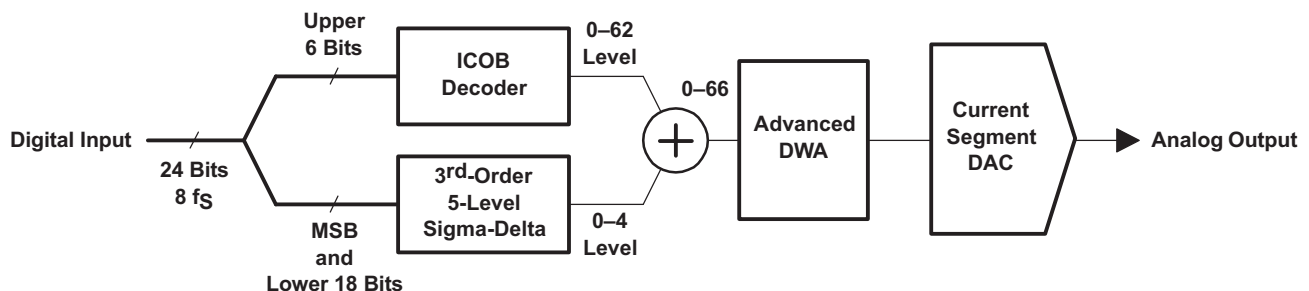

Figure 23. Advanced Segment DAC

The PCM1794A device uses TI’s advanced segment DAC architecture to achieve excellent dynamic performance and improved tolerance to clock jitter. The PCM1794A device provides balanced current outputs.

Digital input data using the digital filter is separated into 6 upper bits and 18 lower bits. The 6 upper bits are converted to inverted complementary offset binary (ICOB) code. The lower 18 bits, associated with the MSB, are processed by a five-level, third-order delta-sigma modulator operated at $64 f_s$ by default. The 1 level of the modulator is equivalent to the 1 LSB of the ICOB code converter. The data groups processed in the ICOB converter and third-order delta-sigma modulator are summed together to create an up-to-66-level digital code, and then processed by data-weighted averaging (DWA) to reduce the noise produced by element mismatch. The data of up to 66 levels from the DWA is converted to an analog output in the differential-current segment section.

This architecture has overcome the various drawbacks of conventional multibit processing, and also achieves excellent dynamic performance.

7.3.9 Analog Output

Table 4 and Figure 24 show the relationship between the digital input code and analog output.

Table 4. Digital Input Code and Analog Output

	800000 (–FS)	000000 (BPZ)	7FFFFFFF (+FS)
I_{OUTN} [mA]	–2.3	–6.2	–10.1
I_{OUTP} [mA]	–10.1	–6.2	–2.3
V_{OUTN} [V] ⁽¹⁾	–1.725	–4.65	–7.575
V_{OUTP} [V] ⁽¹⁾	–7.575	–4.65	–1.725
V_{OUT} [V] ⁽¹⁾	–2.821	0	2.821

(1) V_{OUTN} is the output of U1, V_{OUTP} is the output of U2, and V_{OUT} is the output of U3 in the measurement circuit of Figure 25.

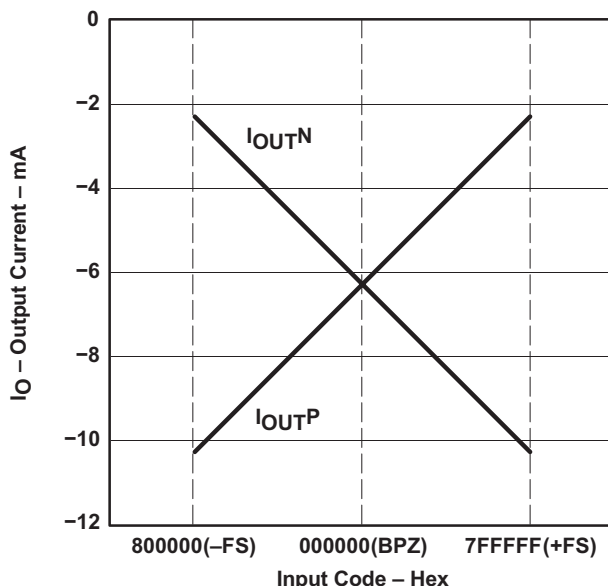

Figure 24. Relationship Between Digital Input and Analog Output

7.4 Device Functional Modes

7.4.1 Device Control

The PCM1794A device is a hardware controlled by external pins. These pins can be tied high or low directly to GND or to V_{DD} . These pins can also be controlled by the GPIO of a host controller.

7.4.2 Audio Input Modes

The PCM1794A device accepts PCM audio in I2S, Right justified (standard), or Left justified formats. The PCM1794 device has an internal digital filter that has the option of a slow or sharp roll off. Use an external digital filter to bypass the internal digital filter. External filter mode is explained more in the [Interfacing With an External Digital Filter](#) section.

7.4.3 Audio Output Modes

With the use of the MONO pin, the PCM1794A can output either differential stereo audio, or differential mono audio. [Figure 25](#) shows an example of stereo output. [Figure 27](#) shows an example of mono mode.

8 Application and Implementation

NOTE

Information in the following applications sections is not part of the TI component specification, and TI does not warrant its accuracy or completeness. TI's customers are responsible for determining suitability of components for their purposes. Customers should validate and test their design implementation to confirm system functionality.

8.1 Application Information

The design of the application circuit lets the user realize the high signal-to-noise (S/N) ratio of the PCM1794A device, as noise and distortion generated in an application circuit are not negligible.

In the circuit of [Figure 25](#), the output level is $2\text{-}V_{\text{RMS}}$, and 127-dB S/N is achieved. The circuit of [Figure 26](#) should result in the highest performance. In this case the output level is set to $4.5\text{-}V_{\text{RMS}}$, and 129-dB S/N is achieved (stereo mode). In monaural mode, if the output of the L-channel and R-channel is used as a balanced output, 132-dB S/N is achieved (see [Figure 27](#)).

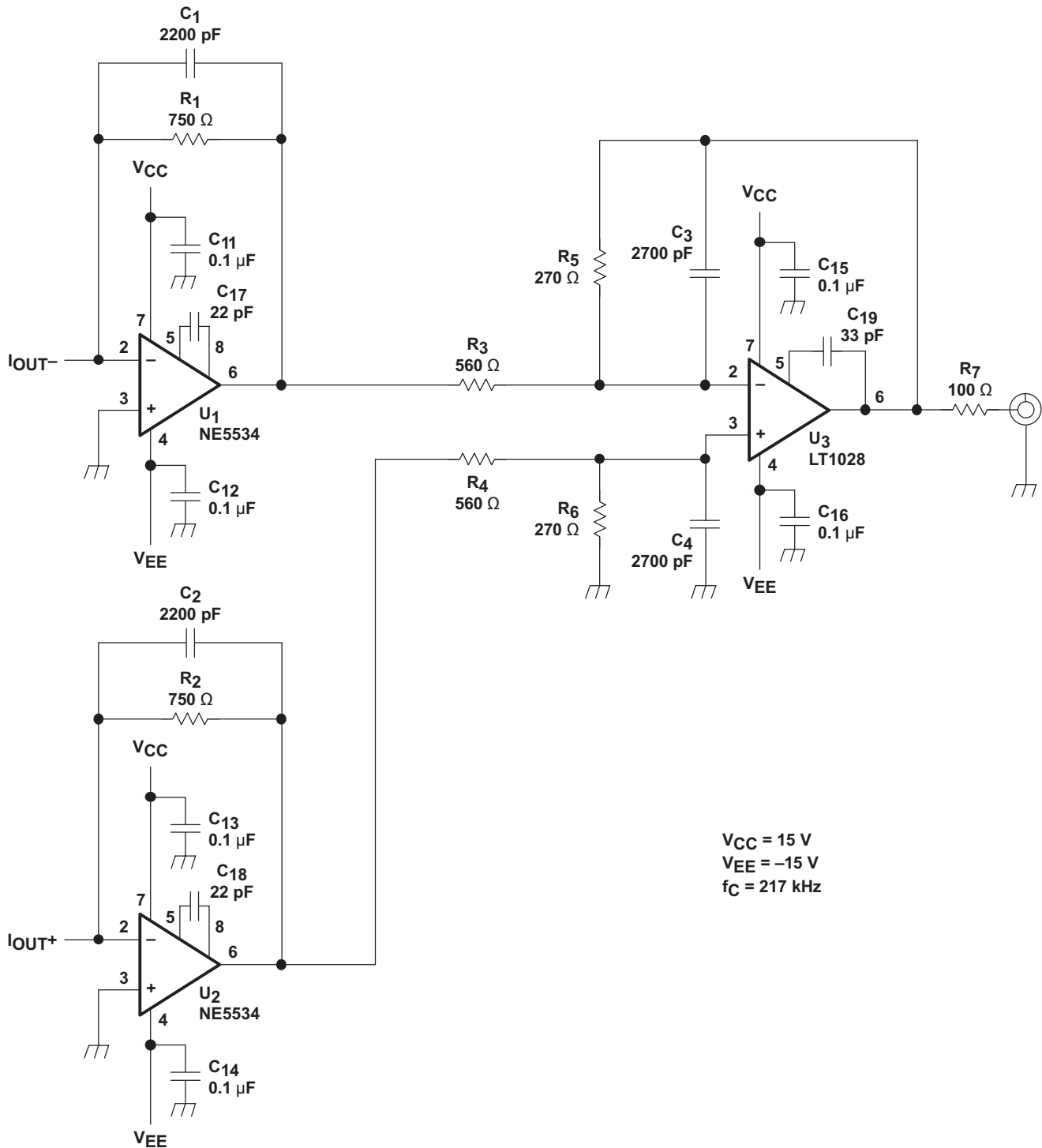
Application Information (continued)

Figure 25. Measurement Circuit, V_{OUT} = 2·V_{RMS}

Application Information (continued)

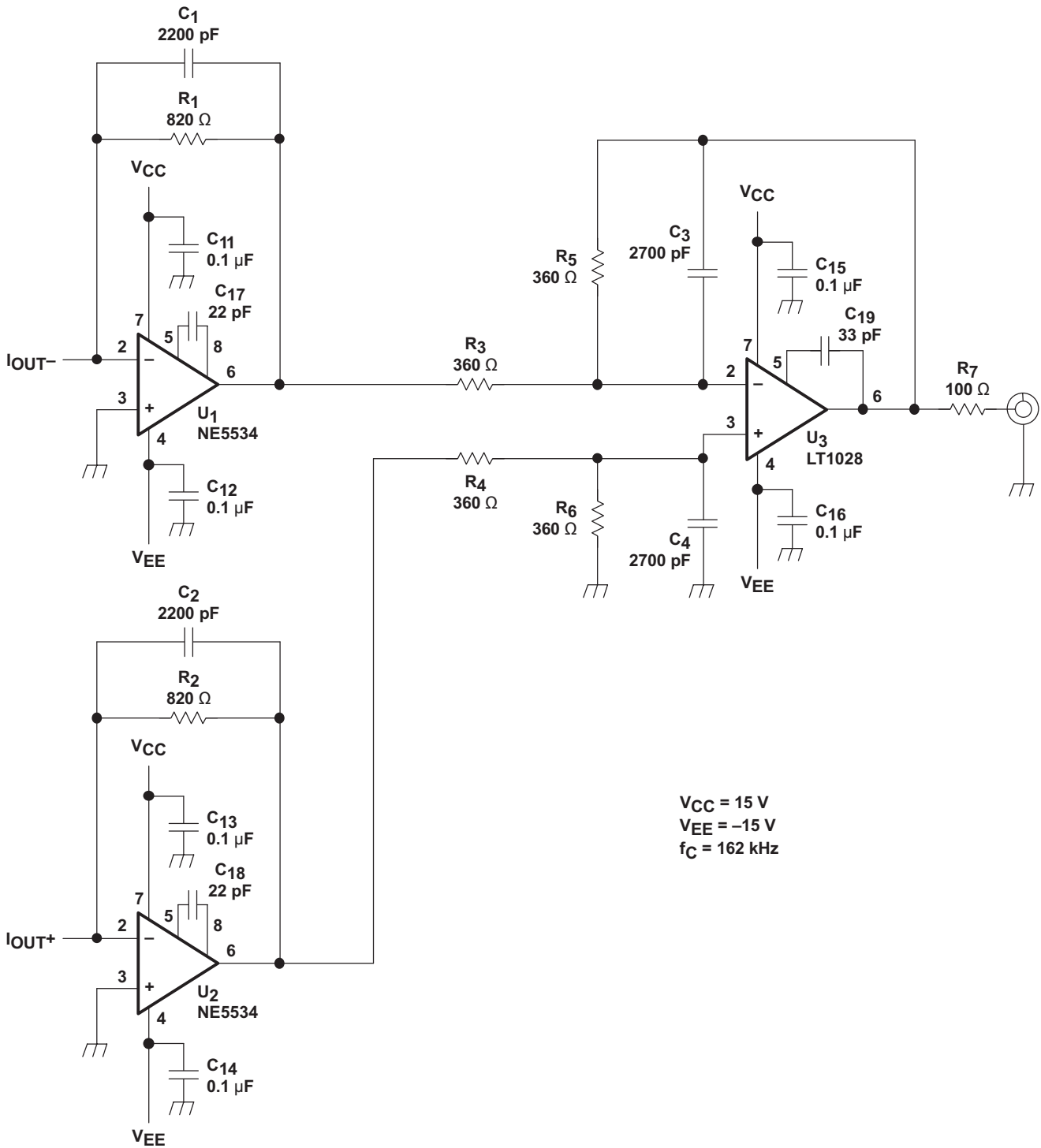
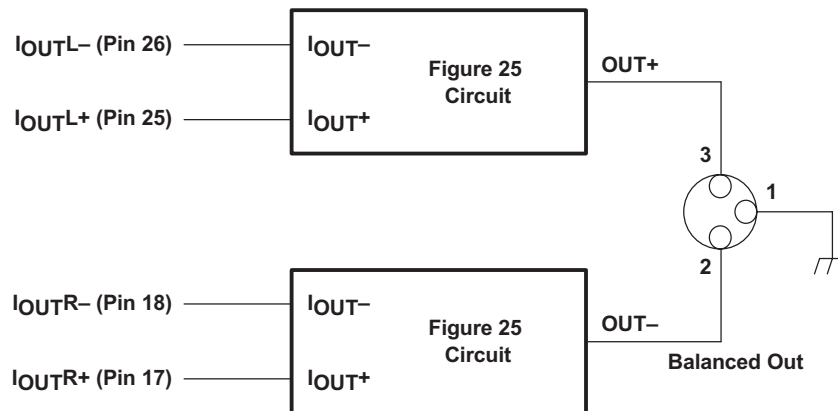

Figure 26. Measurement Circuit, $V_{OUT} = 4.5\text{-}V_{RMS}$

Application Information (continued)

Figure 27. Measurement Circuit for Monaural Mode
8.1.1 I/V Section

The current of the PCM1794A device on each of the output pins (I_{OUTL+} , I_{OUTL-} , I_{OUTR+} , I_{OUTR-}) is 7.8 mA p-p at 0 dB (full scale). Use [Equation 1](#) to calculate the voltage output level of the I/V converter (V_i).

$$V_i = 7.8 \text{ mA p-p} \times R_f$$

where

- R_f is the feedback resistance of I/V converter (1)

An NE5534 operational amplifier is recommended for the I/V circuit to obtain the specified performance. Dynamic performance such as the gain bandwidth, settling time, and slew rate of the operational amplifier affects the audio dynamic performance of the I/V section.

8.1.2 Differential Section

The PCM1794A voltage outputs are followed by differential amplifier stages, which sum the differential signals for each channel, creating a single-ended I/V op-amp output. In addition, the differential amplifiers provide a low-pass filter function.

The operational amplifier recommended for the differential circuit is the Linear Technology LT1028, because the input noise is low.

8.1.3 Interfacing With an External Digital Filter

For some applications, using a programmable digital signal processor as an external digital filter to perform the interpolation function may be necessary. The following pin settings enable the external digital filter application mode:

- MONO (pin 1) = LOW
- CHSL (pin 2) = HIGH
- FMT0 (pin 11) = HIGH
- FMT1 (pin 12) = HIGH

The pins that provide the serial interface for the external digital filter are shown in the connection diagram of [Figure 28](#). The word clock (WDCK) must be operated at 8x or 4x the desired sampling frequency, f_s .

Application Information (continued)

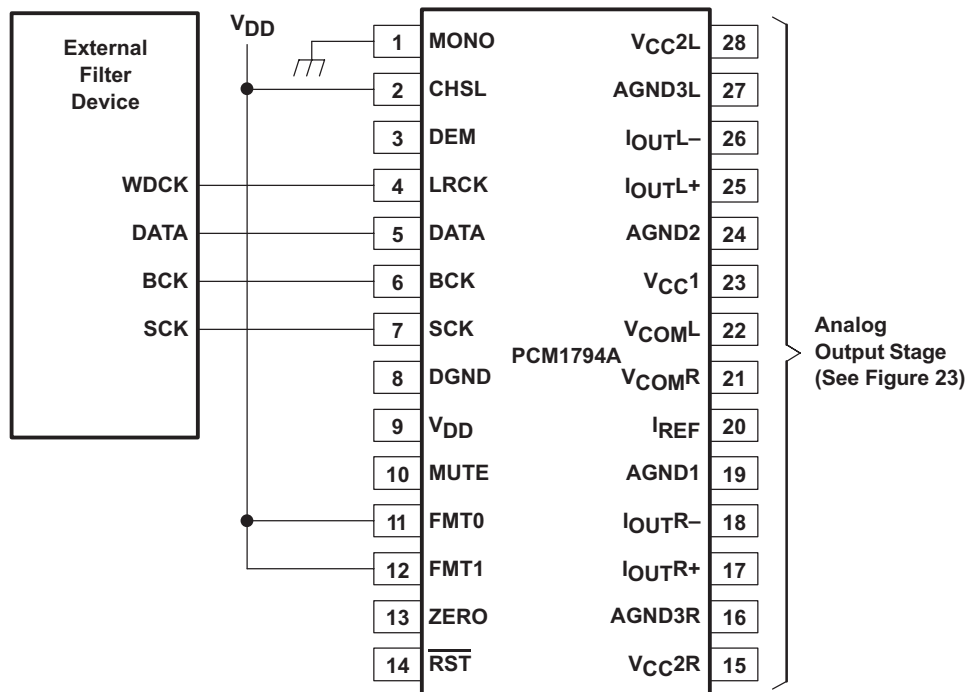

Figure 28. Connection Diagram for External Digital Filter (Internal DF Bypass Mode) Application

8.1.3.1 System Clock (SCK) and Interface Timing

In an application using an external digital filter, the PCM1794A device requires the synchronization of WDCK and the system clock. The system clock is phase-free with respect to WDCK. Interface timing among WDCK, BCK, and DATA is shown in Figure 29.

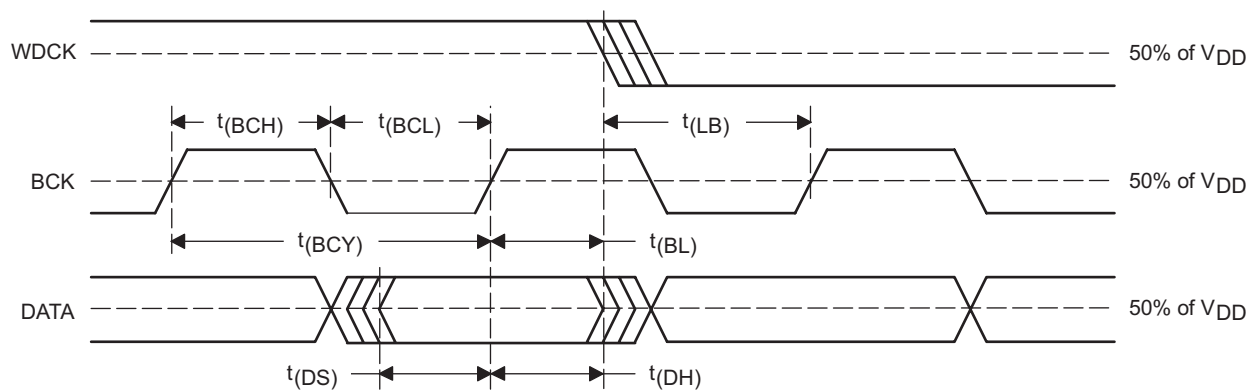

Figure 29. Audio Interface Timing for External Digital Filter (Internal DF Bypass Mode) Application

Table 5 shows the timing requirements for an application using an external digital filter in internal DF bypass mode.

Application Information (continued)
Table 5. External Digital Filter Application Timing Requirements

		MIN	MAX	UNIT
$t_{(BCY)}$	BCK pulse-cycle time	20		ns
$t_{(BCL)}$	BCK pulse duration, LOW	7		ns
$t_{(BCH)}$	BCK pulse duration, HIGH	7		ns
$t_{(BL)}$	BCK rising edge to WDCK falling edge	5		ns
$t_{(LB)}$	WDCK falling edge to BCK rising edge	5		ns
$t_{(DS)}$	DATA setup time	5		ns
$t_{(DH)}$	DATA hold time	5		ns

8.1.3.2 Audio Format

The PCM1794A device in the external digital filter interface mode supports right-justified audio formats, including 24-bit audio data, as shown in [Figure 30](#).

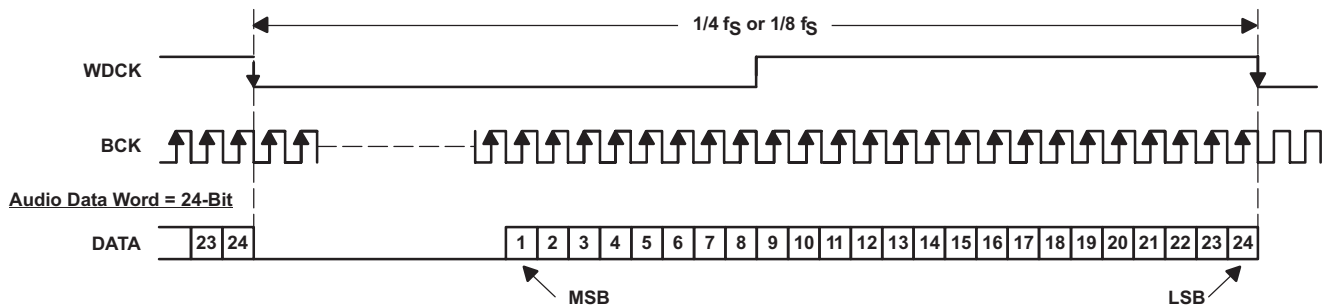
Figure 30. Audio Data Input Format for External Digital Filter (Internal DF Bypass Mode) Application

8.2 Typical Application

This application is using the GPIO of a host controller to manipulate the hardware control pins. A PCM audio source is supplying digital audio and the output is single-ended stereo audio.

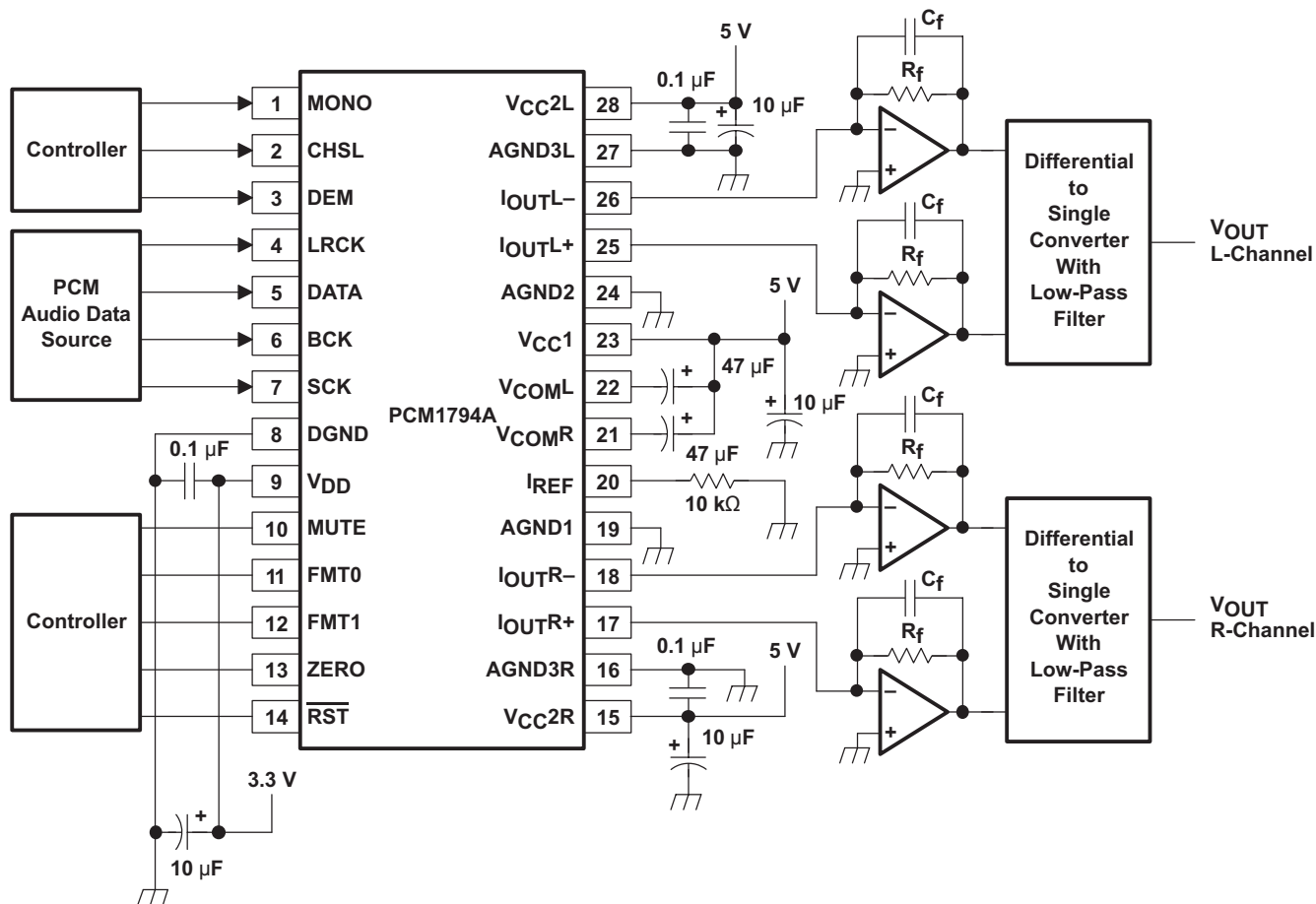

Figure 31. Typical Application Circuit

8.2.1 Design Requirements

For the typical application example, use the parameters listed in Table 6.

Table 6. Design Parameters

DESIGN PARAMETER	EXAMPLE
Audio Input	Digital PCM
Audio Output	Single-Ended Stereo Analog
Control	Host GPIO
Filter	Internal Filter

8.2.2 Detailed Design Procedure

8.2.2.1 Audio Input or Output

In this application, a PCM audio source is supplied to the device. A current output is produced and then converted to a voltage output in the I/V stage. The next stage in the output is a differential to single-ended amplifier stage with a low pass filter to reduce out of band noise. The f_c of the example circuits (Figure 26 and Figure 27) are shown in the example figures. Use Equation 2 to calculate the value of f_c .

$$f_c = 1 / (2 \times \pi \times R_f \times C_f) \quad (2)$$

Typical Application (continued)

8.2.3 Application Curves

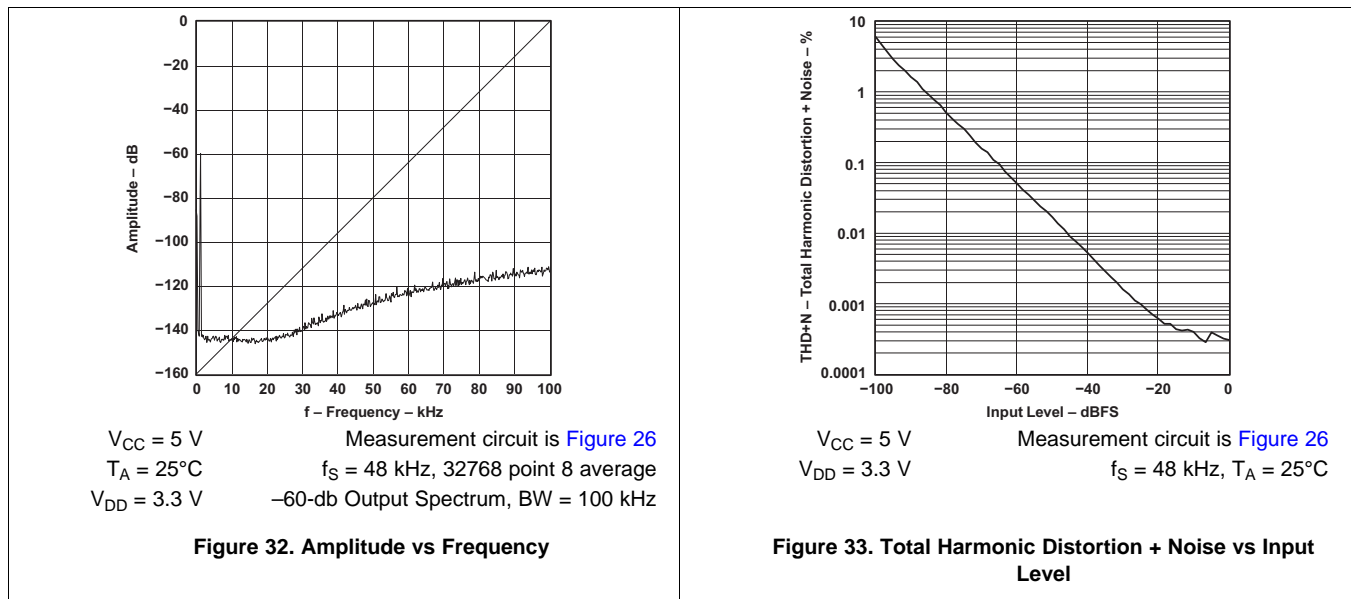

9 Power Supply Recommendations

The PCM1794A device requires 5-V (nominal) supplies. A 5-V supply is required for the analog circuitry powered by the VCC1, VCC2L, and VCC2R pins. A second 5-V supply is for the digital circuitry powered by the V_{DD} pin. These pins can be powered by the same 5-V rail but separating the supplies can assist with getting the target SNR and THD in some cases. Place the decoupling capacitors for the power supplies close to the device terminals.

10 Layout

10.1 Layout Guidelines

TI recommends using the same ground between AGND and DGND to avoid any potential voltage difference between them. Ensure the return currents for digital signals avoid the AGND pin or the input signals to the I/V stage. Avoid running high frequency clock and control signals near AGND, or any of the I_{OUT} pins where possible. The pin layout of the PCM1794A partitions into two parts: an analog section and a digital section. If the system is partitioned in such a way that digital signals are routed away from the analog sections, then no digital return currents (for example, clocks) should be generated in the analog circuitry.

Place the decoupling capacitors as close to the V_{CC1}, V_{CC2L}, V_{CC2R}, V_{COML}, V_{COMR}, and V_{DD} pins as possible. See [Figure 34](#) for additional guidelines.

10.2 Layout Example

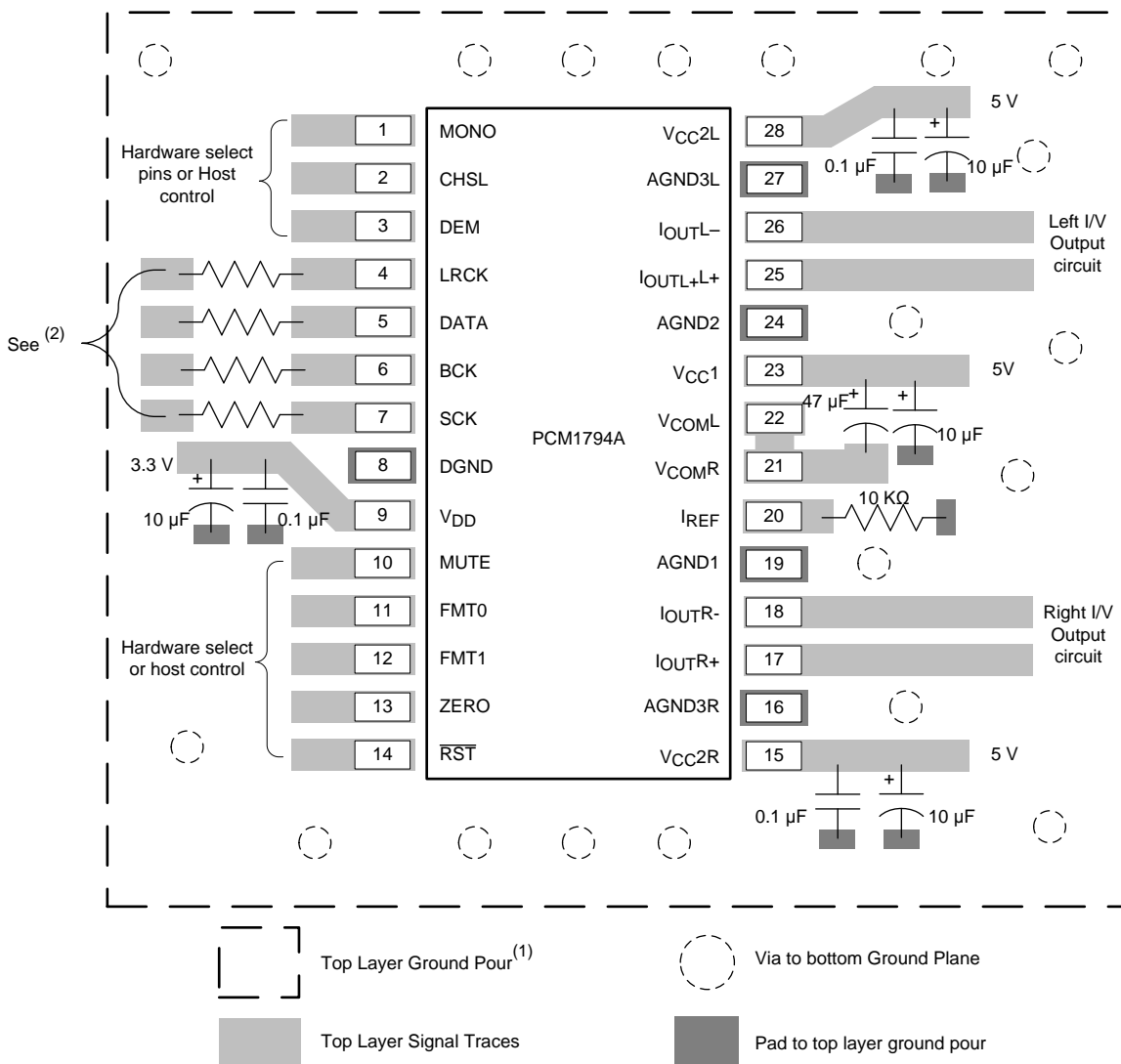

- (1) TI recommends to place a top layer ground pour for shielding around device and connect it to the lower main PCB ground plane with multiple vias.
- (2) These resistors help prevent overshoot and reduce coupling. Begin with a value of 10 Ω for the MCLK resistor and 27 Ω for the other resistors.

Figure 34. PCM1794A Layout Example

11 器件和文档支持

11.1 文档支持

11.1.1 相关文档

相关文档如下：

- 《适用于抗混叠和抗成像滤波器的低噪声、低失真设计》，[SBAA001](#)
- 《PCM1717/18/19/20/23/27 的 HD+N 与频率特性及频谱》，[SBAA020](#)
- 《DEM-PCM1792、DEM-DSD1792、DEM-PCM1794 和 DEM-DSD1794 EVM 板》，[SLEU037](#)
- 《NE5534x、SA5534x 低噪声运算放大器》，[SLOS070](#)
- PLL1700 《多时钟发生器》，[SBOS096](#)

11.2 社区资源

The following links connect to TI community resources. Linked contents are provided "AS IS" by the respective contributors. They do not constitute TI specifications and do not necessarily reflect TI's views; see TI's [Terms of Use](#).

TI E2E™ Online Community *TI's Engineer-to-Engineer (E2E) Community*. Created to foster collaboration among engineers. At e2e.ti.com, you can ask questions, share knowledge, explore ideas and help solve problems with fellow engineers.

Design Support *TI's Design Support* Quickly find helpful E2E forums along with design support tools and contact information for technical support.

11.3 商标

E2E is a trademark of Texas Instruments.

Audio Precision is a trademark of Audio Precision.

All other trademarks are the property of their respective owners.

11.4 静电放电警告



这些装置包含有限的内置 ESD 保护。存储或装卸时，应将导线一起截短或将装置放置于导电泡棉中，以防止 MOS 门极遭受静电损伤。

11.5 Glossary

[SLYZ022](#) — *TI Glossary*.

This glossary lists and explains terms, acronyms, and definitions.

12 机械、封装和可订购信息

以下页中包括机械、封装和可订购信息。这些信息是针对指定器件可提供的最新数据。这些数据会在无通知且不对本文档进行修订的情况下发生改变。欲获得该数据表的浏览器版本，请查阅左侧的导航栏。

PACKAGING INFORMATION

Orderable part number	Status (1)	Material type (2)	Package Pins	Package qty Carrier	RoHS (3)	Lead finish/ Ball material (4)	MSL rating/ Peak reflow (5)	Op temp (°C)	Part marking (6)
PCM1794ADB	Active	Production	SSOP (DB) 28	47 TUBE	Yes	NIPDAU	Level-1-260C-UNLIM	-25 to 85	PCM1794 A
PCM1794ADB.B	Active	Production	SSOP (DB) 28	47 TUBE	Yes	NIPDAU	Level-1-260C-UNLIM	-25 to 85	PCM1794 A
PCM1794ADBR	Active	Production	SSOP (DB) 28	2000 LARGE T&R	Yes	NIPDAU	Level-1-260C-UNLIM	-25 to 85	PCM1794 A
PCM1794ADBR.B	Active	Production	SSOP (DB) 28	2000 LARGE T&R	Yes	NIPDAU	Level-1-260C-UNLIM	-25 to 85	PCM1794 A

(1) **Status:** For more details on status, see our [product life cycle](#).

(2) **Material type:** When designated, preproduction parts are prototypes/experimental devices, and are not yet approved or released for full production. Testing and final process, including without limitation quality assurance, reliability performance testing, and/or process qualification, may not yet be complete, and this item is subject to further changes or possible discontinuation. If available for ordering, purchases will be subject to an additional waiver at checkout, and are intended for early internal evaluation purposes only. These items are sold without warranties of any kind.

(3) **RoHS values:** Yes, No, RoHS Exempt. See the [TI RoHS Statement](#) for additional information and value definition.

(4) **Lead finish/Ball material:** Parts may have multiple material finish options. Finish options are separated by a vertical ruled line. Lead finish/Ball material values may wrap to two lines if the finish value exceeds the maximum column width.

(5) **MSL rating/Peak reflow:** The moisture sensitivity level ratings and peak solder (reflow) temperatures. In the event that a part has multiple moisture sensitivity ratings, only the lowest level per JEDEC standards is shown. Refer to the shipping label for the actual reflow temperature that will be used to mount the part to the printed circuit board.

(6) **Part marking:** There may be an additional marking, which relates to the logo, the lot trace code information, or the environmental category of the part.

Multiple part markings will be inside parentheses. Only one part marking contained in parentheses and separated by a "-" will appear on a part. If a line is indented then it is a continuation of the previous line and the two combined represent the entire part marking for that device.

Important Information and Disclaimer: The information provided on this page represents TI's knowledge and belief as of the date that it is provided. TI bases its knowledge and belief on information provided by third parties, and makes no representation or warranty as to the accuracy of such information. Efforts are underway to better integrate information from third parties. TI has taken and continues to take reasonable steps to provide representative and accurate information but may not have conducted destructive testing or chemical analysis on incoming materials and chemicals. TI and TI suppliers consider certain information to be proprietary, and thus CAS numbers and other limited information may not be available for release.

In no event shall TI's liability arising out of such information exceed the total purchase price of the TI part(s) at issue in this document sold by TI to Customer on an annual basis.

OTHER QUALIFIED VERSIONS OF PCM1794A :

- Automotive : [PCM1794A-Q1](#)

NOTE: Qualified Version Definitions:

- Automotive - Q100 devices qualified for high-reliability automotive applications targeting zero defects

TUBE

*All dimensions are nominal

Device	Package Name	Package Type	Pins	SPQ	L (mm)	W (mm)	T (μm)	B (mm)
PCM1794ADB	DB	SSOP	28	47	500	10.6	500	9.6
PCM1794ADB.B	DB	SSOP	28	47	500	10.6	500	9.6
PCM1794ADBR	DB	SSOP	28	2000	500	10.6	500	9.6
PCM1794ADBR.B	DB	SSOP	28	2000	500	10.6	500	9.6

DB0028A



PACKAGE OUTLINE

SSOP - 2 mm max height

SMALL OUTLINE PACKAGE

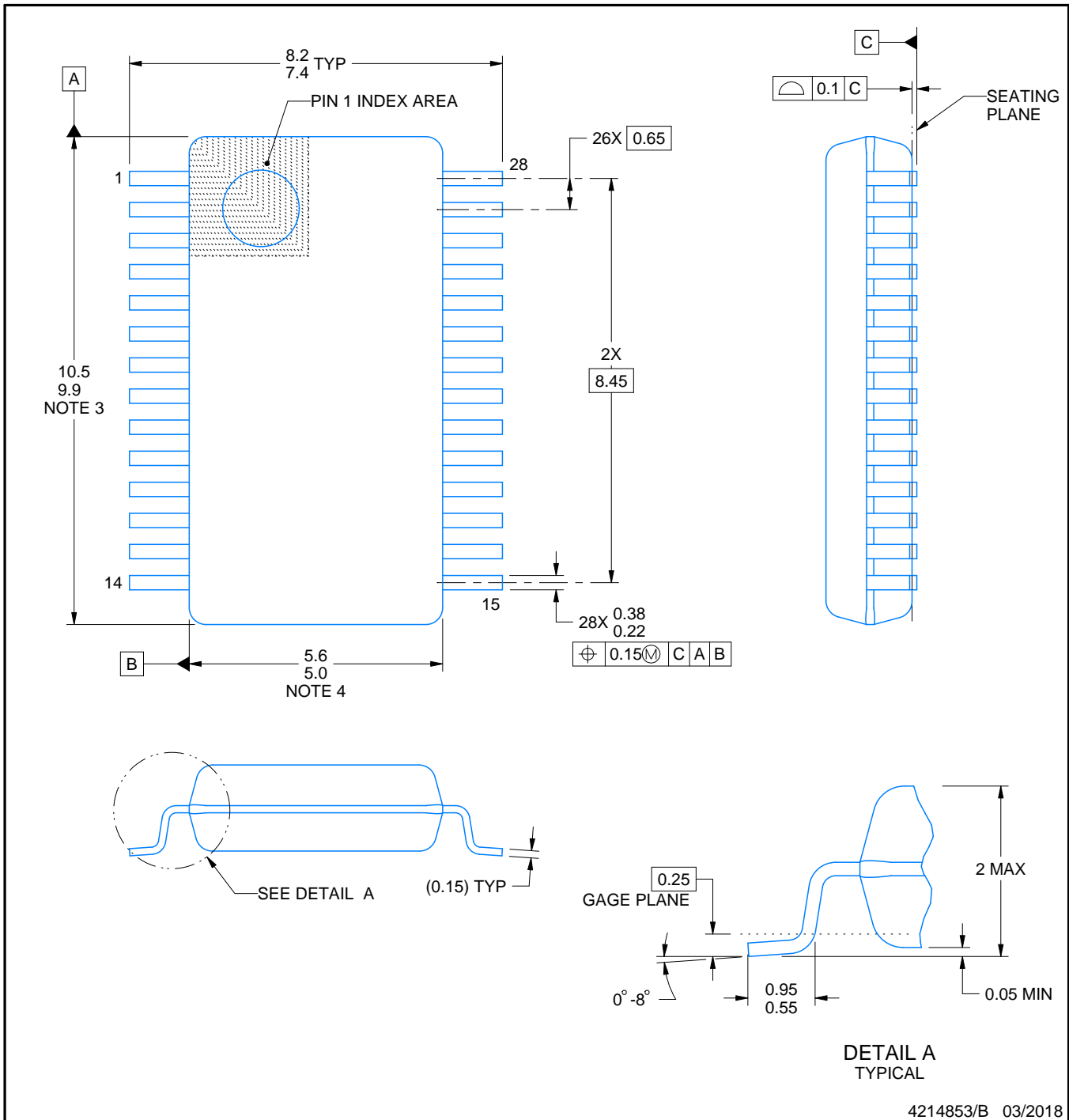

4214853/B 03/2018

NOTES:

1. All linear dimensions are in millimeters. Any dimensions in parenthesis are for reference only. Dimensioning and tolerancing per ASME Y14.5M.
2. This drawing is subject to change without notice.
3. This dimension does not include mold flash, protrusions, or gate burrs. Mold flash, protrusions, or gate burrs shall not exceed 0.15 mm per side.
4. This dimension does not include interlead flash. Interlead flash shall not exceed 0.25 mm per side.
5. Reference JEDEC registration MO-150.

EXAMPLE BOARD LAYOUT

DB0028A

SSOP - 2 mm max height

SMALL OUTLINE PACKAGE

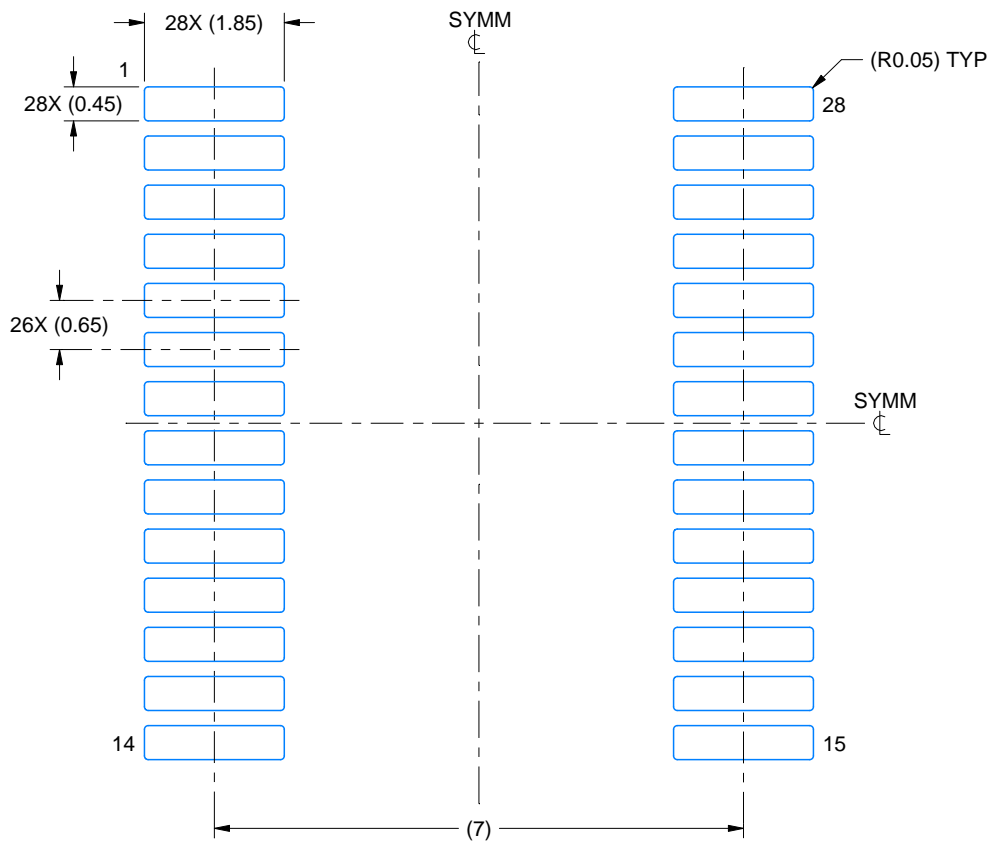

LAND PATTERN EXAMPLE
EXPOSED METAL SHOWN
SCALE: 10X

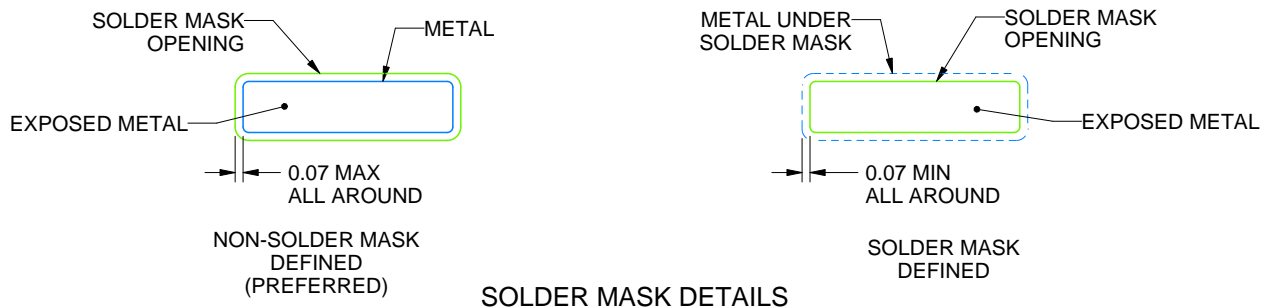

4214853/B 03/2018

NOTES: (continued)

- 6. Publication IPC-7351 may have alternate designs.
- 7. Solder mask tolerances between and around signal pads can vary based on board fabrication site.

EXAMPLE STENCIL DESIGN

DB0028A

SSOP - 2 mm max height

SMALL OUTLINE PACKAGE

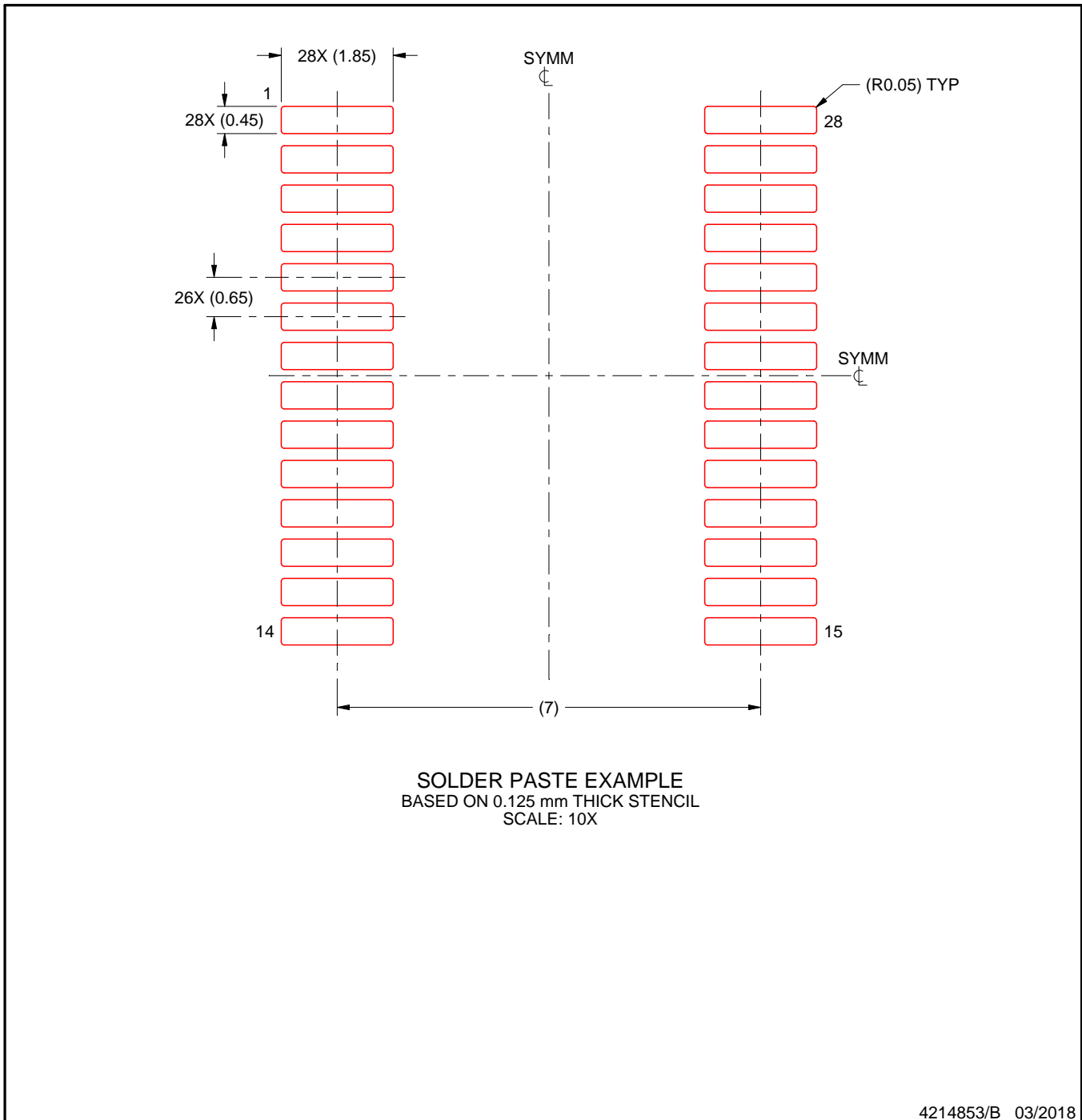

NOTES: (continued)

8. Laser cutting apertures with trapezoidal walls and rounded corners may offer better paste release. IPC-7525 may have alternate design recommendations.
9. Board assembly site may have different recommendations for stencil design.

重要通知和免责声明

TI“按原样”提供技术和可靠性数据（包括数据表）、设计资源（包括参考设计）、应用或其他设计建议、网络工具、安全信息和其他资源，不保证没有瑕疵且不做任何明示或暗示的担保，包括但不限于对适销性、与某特定用途的适用性或不侵犯任何第三方知识产权的暗示担保。

这些资源可供使用 TI 产品进行设计的熟练开发人员使用。您将自行承担以下全部责任：(1) 针对您的应用选择合适的 TI 产品，(2) 设计、验证并测试您的应用，(3) 确保您的应用满足相应标准以及任何其他安全、安保法规或其他要求。

这些资源如有变更，恕不另行通知。TI 授权您仅可将这些资源用于研发本资源所述的 TI 产品的相关应用。严禁以其他方式对这些资源进行复制或展示。您无权使用任何其他 TI 知识产权或任何第三方知识产权。对于因您对这些资源的使用而对 TI 及其代表造成的任何索赔、损害、成本、损失和债务，您将全额赔偿，TI 对此概不负责。

TI 提供的产品受 [TI 销售条款](#)、[TI 通用质量指南](#) 或 [ti.com](#) 上其他适用条款或 TI 产品随附的其他适用条款的约束。TI 提供这些资源并不会扩展或以其他方式更改 TI 针对 TI 产品发布的适用的担保或担保免责声明。除非德州仪器 (TI) 明确将某产品指定为定制产品或客户特定产品，否则其产品均为按确定价格收入目录的标准通用器件。

TI 反对并拒绝您可能提出的任何其他或不同的条款。

版权所有 © 2026，德州仪器 (TI) 公司

最后更新日期：2025 年 10 月