

SNx4AHC138 3 线路至 8 线路解码器/多路信号分离器

1 特性

- 工作范围为 2V 至 5.5V V_{CC}
- 专门为高速存储器解码器和数据传输系统设计
- 包含三个使能输入以简化级联和/或数据接收
- 闩锁性能超过 250mA，符合 JESD 17 规范
- ESD 保护性能超过 JESD 22 规范要求：
 - 2000V 人体放电模型 (A114-A)
 - 1000V 充电器件模型 (C101)

2 说明

SNx4AHC138 解码器/多路信号分离器设计用于需要极短传播延迟时间的高性能存储器解码和数据路由应用。在高性能存储器系统中，可使用此类解码器来尽可能地消除系统解码的影响。与使用高速使能电路的高速存储器一同使用时，这些解码器的延迟时间和存储器的使能时间通常小于存储器的典型存取时间。这意味着解码器引起的有效系统延迟可以忽略不计。

器件信息

器件型号	封装 ⁽¹⁾	封装尺寸 ⁽²⁾	本体尺寸 ⁽³⁾
SN74AHC138	RGY (VQFN , 16)	4mm x 3.5mm	4mm x 3.5mm
	N (PDIP , 16)	19.3mm x 9.4mm	19.32mm x 6.35mm
	D (SOIC , 16)	9.9mm x 6mm	9.90mm x 3.90mm
	NS (SOP , 16)	10.2mm x 7.8mm	10.20mm x 5.30mm
	DB (SSOP , 16)	6.2mm x 7.8mm	6.20mm x 5.30mm
	PW (TSSOP , 16)	5mm x 6.4mm	5.00mm x 4.40mm
	DGV (TVSOP , 16)	3.6mm x 6.4mm	3.6mm x 4.4mm

- (1) 如需了解更多信息，请参阅机械、封装和可订购信息。
- (2) 封装尺寸（长 × 宽）为标称值，并包括引脚（如适用）。
- (3) 本体尺寸（长 × 宽）为标称值，不包括引脚。

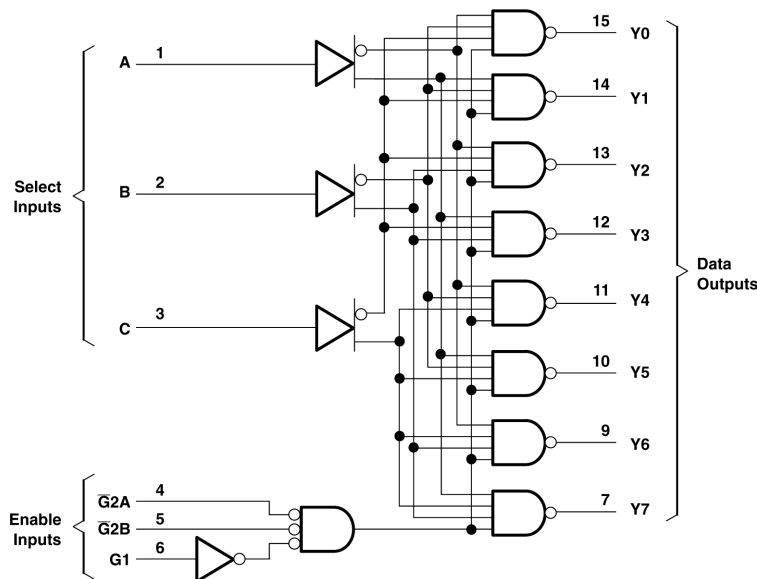

逻辑图 (正逻辑)



内容

1 特性	1	6.3 功能表.....	9
2 说明	1	7 应用和实施	10
3 引脚配置和功能	3	7.1 应用信息.....	10
4 规格	5	7.2 电源相关建议.....	11
4.1 绝对最大额定值.....	5	7.3 布局.....	12
4.2 建议运行条件.....	5	8 器件和文档支持	13
4.3 热性能信息.....	6	8.1 文档支持 (模拟).....	13
4.4 电气特性.....	6	8.2 接收文档更新通知.....	13
4.5 开关特性: $V_{CC} = 3.3V \pm 0.3V$	6	8.3 支持资源.....	13
4.6 开关特性: $V_{CC} = 5V \pm 0.5V$	7	8.4 商标.....	13
4.7 工作特性.....	7	8.5 静电放电警告.....	13
5 参数测量信息	8	8.6 术语表.....	13
6 详细说明	9	9 修订历史记录	13
6.1 概述.....	9	10 机械、封装和可订购信息	14
6.2 功能方框图.....	9		

3 引脚配置和功能

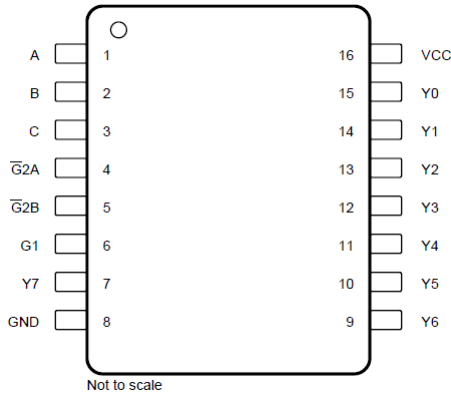

**图 3-1. D、DB、DGV、N、NS 或 PW 封装，16 引脚
 SOIC、SSOP、TVSOP、PDIP、SOP 或 TSSOP
 (顶视图)**

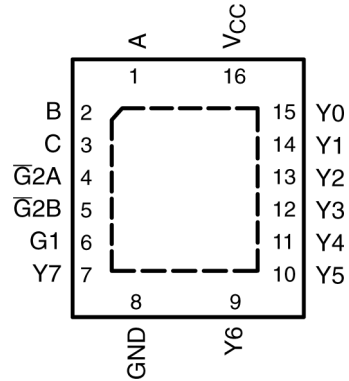

**图 3-2. RGY 封装，
 16 引脚 VQFN
 (顶视图)**

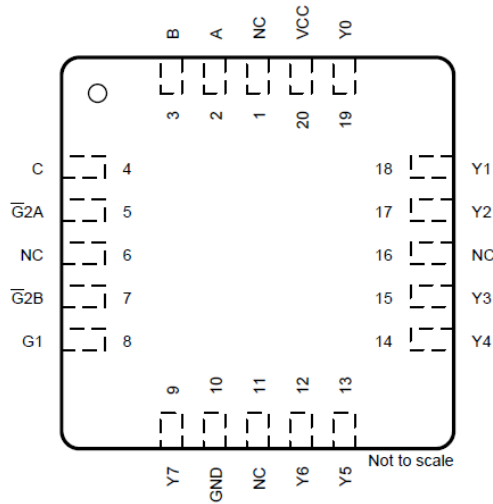

NC : 无内部连接

**图 3-3. FK 封装，
 20 引脚 LCCC
 (顶视图)**

表 3-1. 引脚功能

引脚		类型 ⁽¹⁾	说明
名称	编号		
A ₀	1	I	地址选择 0
A ₁	2	I	地址选择 1
A ₂	3	I	地址选择 2
\bar{G}_0	4	I	输出选通 0, 低电平有效
\bar{G}_1	5	I	输出选通 1, 低电平有效
G ₂	6	I	输出选通 2
Y ₇	7	O	输出 7
GND	8	G	接地
Y ₆	9	O	输出 6
Y ₅	10	O	输出 5
Y ₄	11	O	输出 4
Y ₃	12	O	输出 3
Y ₂	13	O	输出 2
Y ₁	14	O	输出 1
Y ₀	15	O	输出 0
V _{CC}	16	P	正电源
散热焊盘 ⁽²⁾			散热焊盘可连接到 GND 或悬空。请勿连接到任何其他信号或电源。

(1) 信号类型: I = 输入, O = 输出, I/O = 输入或输出, P = 电源, G = 接地。

(2) 仅限 WBQB 封装。

4 规格

4.1 绝对最大额定值

在自然通风条件下的工作温度范围内测得（除非另有说明）⁽¹⁾

		最小值	最大值	单位
V _{CC}	电源电压范围	-0.5	7	V
V _I ⁽²⁾	输入电压范围	-0.5	7	V
V _O ⁽²⁾	输出电压范围	-0.5	V _{CC} + 0.5	V
I _{IK}	输入钳位电流 (V _I < 0)		-20	mA
I _{OK}	输出钳位电流 (V _O < 0 或 V _O > V _{CC})		±20	mA
I _O	持续输出电流 (V _O = 0 至 V _{CC})		±25	mA
通过 V _{CC} 或 GND 的持续电流			±75	mA
T _{stg}	贮存温度范围	-65	150	°C

- (1) 应力超出“绝对最大额定值”下列出的值可能会对器件造成永久损坏。这些仅为在应力额定值下的工作情况，对于额定值下的器件的功能性操作或者在超出“推荐的操作条件”下的任何其它情况，在此并未说明。长时间处于绝对最大额定条件下可能会影响器件的可靠性。
- (2) 如果遵守输入和输出电流额定值，输入和输出电压可超过额定值。

4.2 建议运行条件

在自然通风条件下的工作温度范围内测得（除非另有说明）⁽¹⁾

		SN54AHC138		SN74AHC138		单位
		最小值	最大值	最小值	最大值	
V _{CC}	电源电压	2	5.5	2	5.5	V
V _{IH}	高电平输入电压	V _{CC} = 2 V	1.5	1.5		V
		V _{CC} = 3 V	2.1	2.1		
		V _{CC} = 5.5 V	3.85	3.85		
V _{IL}	低电平输入电压	V _{CC} = 2 V		0.5	0.5	V
		V _{CC} = 3 V		0.9	0.9	
		V _{CC} = 5.5 V		1.65	1.65	
V _I	输入电压		0 5.5		0 5.5	V
V _O	输出电压	0	V _{CC}	0	V _{CC}	V
I _{OH}	高电平输出电流	V _{CC} = 2 V		-50	-50	mA
		V _{CC} = 3.3 V ± 0.3 V		-4	-4	mA
		V _{CC} = 5 V ± 0.5 V		-8	-8	mA
I _{OL}	低电平输出电流	V _{CC} = 2 V		50	50	mA
		V _{CC} = 3.3 V ± 0.3 V		4	4	mA
		V _{CC} = 5 V ± 0.5 V		8	8	mA
Δt/Δv	输入转换上升或下降速率	V _{CC} = 3.3 V ± 0.3 V		100	100	ns/V
		V _{CC} = 5 V ± 0.5 V		20	20	
T _A	自然通风条件下的工作温度范围	-55	125	-40	85	°C

- (1) 器件所有的未使用输入必须保持在 V_{CC} 或 GND 以确保器件正常运行。请参阅 TI 应用报告 *CMOS 输入缓慢变化或悬空的影响*，文献编号 SCBA004。

4.3 热性能信息

热性能指标 ⁽¹⁾		SN74AHC138							单位
		D (SOIC)	DB (SSOP)	DGV (TVSOP)	N (PDIP)	NS (SOP)	PW (TSSOP)	RGY (VQFN)	
		16							
$R_{\theta JA}$	结至环境热阻	93.8	82	120	67	64	135.9	39	°C/W

(1) 有关新旧热指标的更多信息，请参阅 [半导体和 IC 封装热指标](#) 应用报告。

4.4 电气特性

在自然通风条件下的建议运行温度范围内测得（除非另有说明）

参数	测试条件	V_{CC}	$T_A = 25^\circ\text{C}$			SN54AHC138		SN74AHC138		单位
			最小值	典型值	最大值	最小值	最大值	最小值	最大值	
V_{OH}	$I_{OH} = -50 \mu\text{A}$	2 V	1.9	2		1.9		1.9	V	
		3 V	2.9	3		2.9		2.9		
		4.5 V	4.4	4.5		4.4		4.4		
	$I_{OH} = -4 \text{ mA}$	3 V	2.58			2.48		2.48		
	$I_{OH} = -8 \text{ mA}$	4.5 V	3.94			3.8		3.8		
V_{OL}	$I_{OL} = 50 \mu\text{A}$	2 V		0.1			0.1		0.1	V
		3 V		0.1			0.1		0.1	
		4.5 V		0.1			0.1		0.1	
	$I_{OL} = 4 \text{ mA}$	3 V		0.36			0.5		0.44	
	$I_{OL} = 8 \text{ mA}$	4.5 V		0.36			0.5		0.44	
I_I	$V_I = 5.5 \text{ V}$ 或 GND	0 V 至 5.5 V		± 0.1		$\pm 1^{(1)}$		± 1	μA	
I_{CC}	$V_I = V_{CC}$ 或 GND, $I_O = 0$	5.5 V		4		40		40	μA	
C_i	$V_I = V_{CC}$ 或 GND	5 V		2 10				10	pF	

(1) 对于符合 MIL-PRF-38535 标准的产品，此参数未经量产测试（在 $V_{CC} = 0\text{V}$ 时）。

4.5 开关特性： $V_{CC} = 3.3\text{V} \pm 0.3\text{V}$

在推荐的自然通风条件下的工作温度范围内测得， $V_{CC} = 3.3\text{V} \pm 0.3\text{V}$ （除非另有说明）（请参阅 [负载电路和电压波形](#)）

参数	从（输入）	到（输出）	负载电容	$T_A = 25^\circ\text{C}$			SN54AHC138		SN74AHC138		单位
				最小值	典型值	最大值	最小值	最大值	最小值	最大值	
t_{PLH}	A、B、C	任一 Y	$C_L = 15\text{pF}$		8.2 ⁽¹⁾	11.4 ⁽¹⁾	1 ⁽¹⁾	13 ⁽¹⁾	1	13	ns
t_{PHL}					8.2 ⁽¹⁾	11.4 ⁽¹⁾	1 ⁽¹⁾	13 ⁽¹⁾	1	13	
t_{PLH}	G1	任一 Y	$C_L = 15\text{pF}$		8.1 ⁽¹⁾	12.8 ⁽¹⁾	1 ⁽¹⁾	15 ⁽¹⁾	1	15	ns
t_{PHL}					8.1 ⁽¹⁾	12.8 ⁽¹⁾	1 ⁽¹⁾	15 ⁽¹⁾	1	15	
t_{PLH}	$\overline{G}2A$, $\overline{G}2B$	任一 Y	$C_L = 15\text{pF}$		8.2 ⁽¹⁾	11.4 ⁽¹⁾	1 ⁽¹⁾	13.5 ⁽¹⁾	1	13.5	ns
t_{PHL}					8.2 ⁽¹⁾	11.4 ⁽¹⁾	1 ⁽¹⁾	13.5 ⁽¹⁾	1	13.5	
t_{PLH}	A、B、C	任一 Y	$C_L = 50\text{pF}$		10	15.8	1	18	1	18	ns
t_{PHL}					10	15.8	1	18	1	18	
t_{PLH}	G1	任一 Y	$C_L = 50\text{pF}$		10.6	16.3	1	18.5	1	18.5	ns
t_{PHL}					10.6	16.3	1	18.5	1	18.5	
t_{PLH}	$\overline{G}2A$, $\overline{G}2B$	任一 Y	$C_L = 50\text{pF}$		10.7	14.9	1	17	1	17	ns
t_{PHL}					10.7	14.9	1	17	1	17	

(1) 对于符合 MIL-PRF-38535 标准的产品，此参数未经量产测试。

4.6 开关特性：V_{CC} = 5V ± 0.5V

在推荐的自然通风条件下的工作温度范围内测得，V_{CC} = 5V ± 0.5V (除非另有说明) (请参阅[负载电路和电压波形](#))

参数	从 (输入)	到 (输出)	负载电容	T _A = 25°C			SN54AHC138		SN74AHC138		单位
				最小值	典型值	最大值	最小值	最大值	最小值	最大值	
t _{PLH}	A、B、C	任一 Y	C _L = 15pF	5.7 ⁽¹⁾	8.1 ⁽¹⁾	1 ⁽¹⁾	9.5 ⁽¹⁾	1	9.5	ns	
t _{PHL}				5.7 ⁽¹⁾	8.1 ⁽¹⁾	1 ⁽¹⁾	9.5 ⁽¹⁾	1	9.5		
t _{PLH}	G1	任一 Y	C _L = 15pF	5.6 ⁽¹⁾	8.1 ⁽¹⁾	1 ⁽¹⁾	9.5 ⁽¹⁾	1	9.5	ns	
t _{PHL}				5.6 ⁽¹⁾	8.1 ⁽¹⁾	1 ⁽¹⁾	9.5 ⁽¹⁾	1	9.5		
t _{PLH}	G2A, G2B	任一 Y	C _L = 15pF	5.8 ⁽¹⁾	8.1 ⁽¹⁾	1 ⁽¹⁾	9.5 ⁽¹⁾	1	9.5	ns	
t _{PHL}				5.8 ⁽¹⁾	8.1 ⁽¹⁾	1 ⁽¹⁾	9.5 ⁽¹⁾	1	9.5		
t _{PLH}	A、B、C	任一 Y	C _L = 50pF	7.2	10.1	1	11.5	1	11.5	ns	
t _{PHL}				7.2	10.1	1	11.5	1	11.5		
t _{PLH}	G1	任一 Y	C _L = 50pF	7.1	10.1	1	11.5	1	11.5	ns	
t _{PHL}				7.1	10.1	1	11.5	1	11.5		
t _{PLH}	G2A, G2B	任一 Y	C _L = 50pF	7.3	10.1	1	11.5	1	11.5	ns	
t _{PHL}				7.3	10.1	1	11.5	1	11.5		

(1) 对于符合 MIL-PRF-38535 标准的产品，此参数未经量产测试。

4.7 工作特性

V_{CC} = 5V, T_A = 25°C

参数		测试条件		典型值	单位
C _{pd}	功率耗散电容	无负载,	f = 1 MHz	13	pF

5 参数测量信息

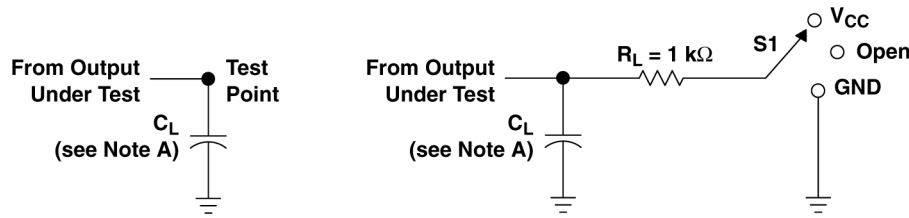

LOAD CIRCUIT FOR TOTEM-POLE OUTPUTS

LOAD CIRCUIT FOR 3-STATE AND OPEN-DRAIN OUTPUTS

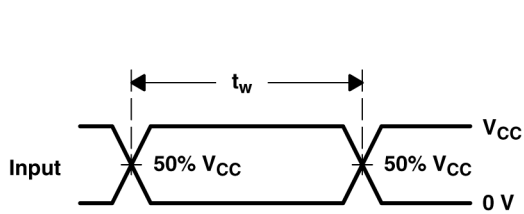

VOLTAGE WAVEFORMS PULSE DURATION

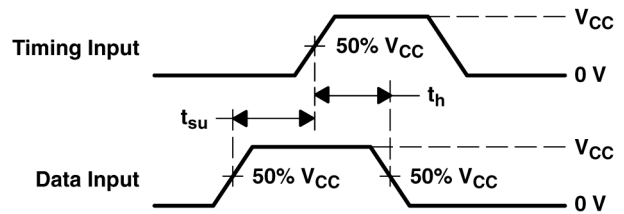

VOLTAGE WAVEFORMS SETUP AND HOLD TIMES

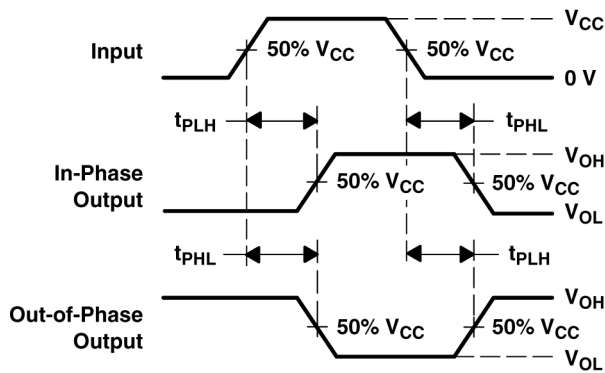

VOLTAGE WAVEFORMS PROPAGATION DELAY TIMES INVERTING AND NONINVERTING OUTPUTS

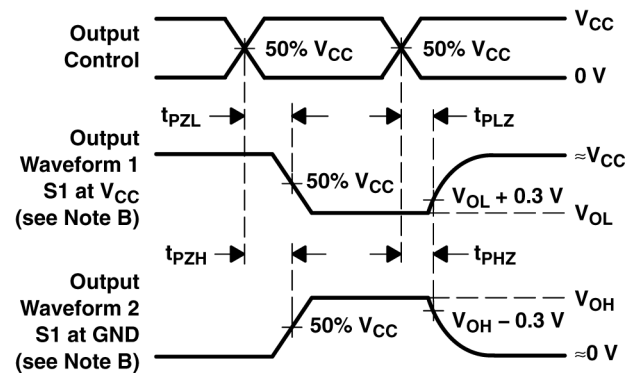

VOLTAGE WAVEFORMS ENABLE AND DISABLE TIMES LOW- AND HIGH-LEVEL ENABLING

- A. C_L 包括探头和夹具电容。
- B. 波形 1 用于具有内部条件的输出，使得输出为低电平，除非被输出控制禁用。波形 2 用于具有内部条件的输出，使得输出为高电平，除非被输出控制禁用。
- C. 所有输入脉冲均由具有以下特性的发生器提供： $PRR \leq 1\text{MHz}$ ， $Z_O = 50\ \Omega$ ， $t_r \leq 3\ \text{ns}$ ， $t_f \leq 3\ \text{ns}$ 。
- D. 一次测量一个输出，每次测量一个输入转换。
- E. 并非所有参数和波形都适用于所有器件。

图 5-1. 负载电路和电压波形

测试	S1
t_{PLH}/t_{PHL}	开路
t_{PZL}/t_{PZH}	V_{CC}
t_{PHZ}/t_{PZH}	GND
漏极开路	V_{CC}

6 详细说明

6.1 概述

二进制选择输入和三个使能输入条件可从八条输出线路中选择其中一条。两个低电平有效使能输入和一个高电平有效使能输入可在扩展时减少对外部门电路或反相器的需要。无需外部反相器即可实现 24 线解码器，并且 32 线解码器只需要一个反相器。使能输入可用作多路信号分离应用的数据输入。

6.2 功能方框图

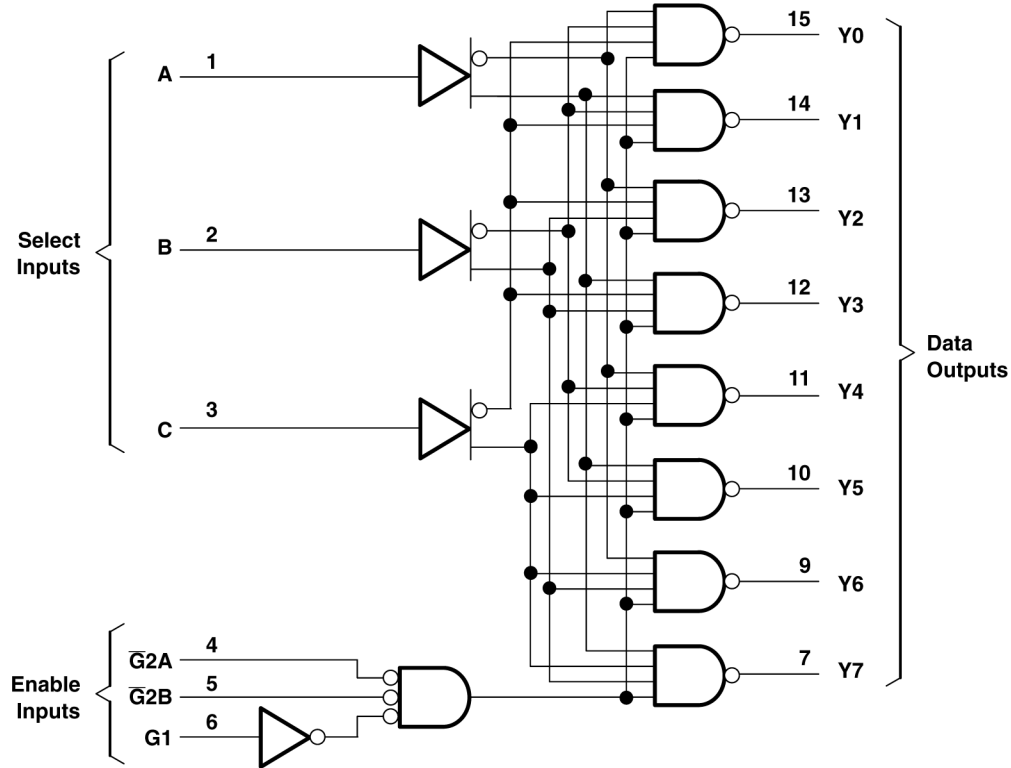

所示引脚编号用于 D、DB、DGV、J、N、NS、PW、RGY 和 W 封装。

6.3 功能表

使能输入			选择输入			输出							
G1	$\overline{G2A}$	$\overline{G2B}$	C	B	A	Y0	Y1	Y2	Y3	Y4	Y5	Y6	Y7
X	H	X	X	X	X	H	H	H	H	H	H	H	H
X	X	H	X	X	X	H	H	H	H	H	H	H	H
L	X	X	X	X	X	H	H	H	H	H	H	H	H
H	L	L	L	L	L	L	H	H	H	H	H	H	H
H	L	L	L	L	H	H	L	H	H	H	H	H	H
H	L	L	L	H	L	H	H	L	H	H	H	H	H
H	L	L	L	H	H	H	H	H	L	H	H	H	H
H	L	L	H	L	L	H	H	H	H	L	H	H	H
H	L	L	H	L	H	H	H	H	H	H	L	H	H
H	L	L	H	H	L	H	H	H	H	H	H	L	H
H	L	L	H	H	H	H	H	H	H	H	H	H	L

7 应用和实施

备注

以下应用部分中的信息不属于 TI 器件规格的范围，TI 不担保其准确性和完整性。TI 的客户应负责确定器件是否适用于其应用。客户应验证并测试其设计，以确保系统功能。

7.1 应用信息



图 7-1. 24 位解码方案



图 7-2. 32 位解码方案

7.2 电源相关建议

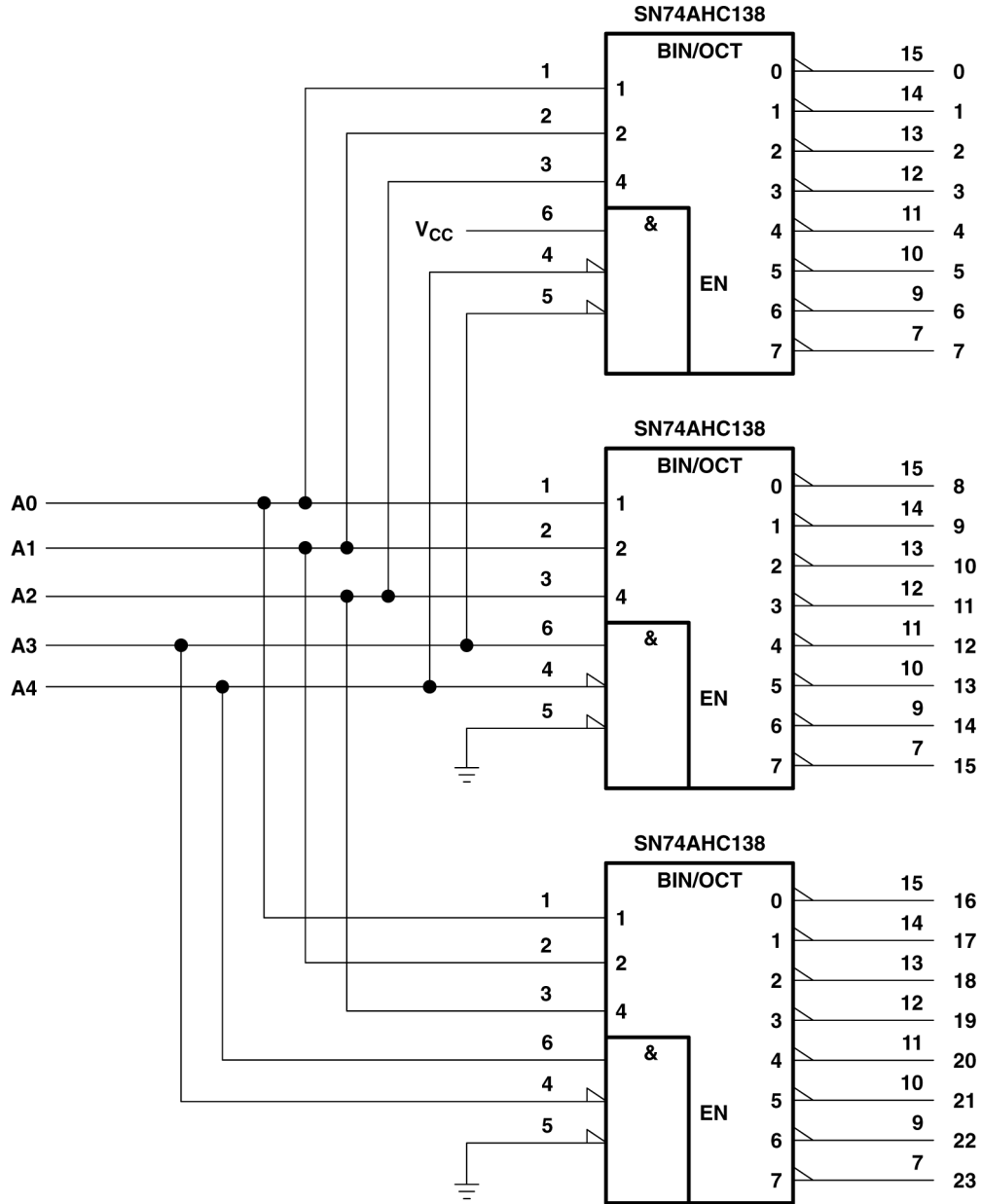
7.3 布局

7.3.1 布局指南

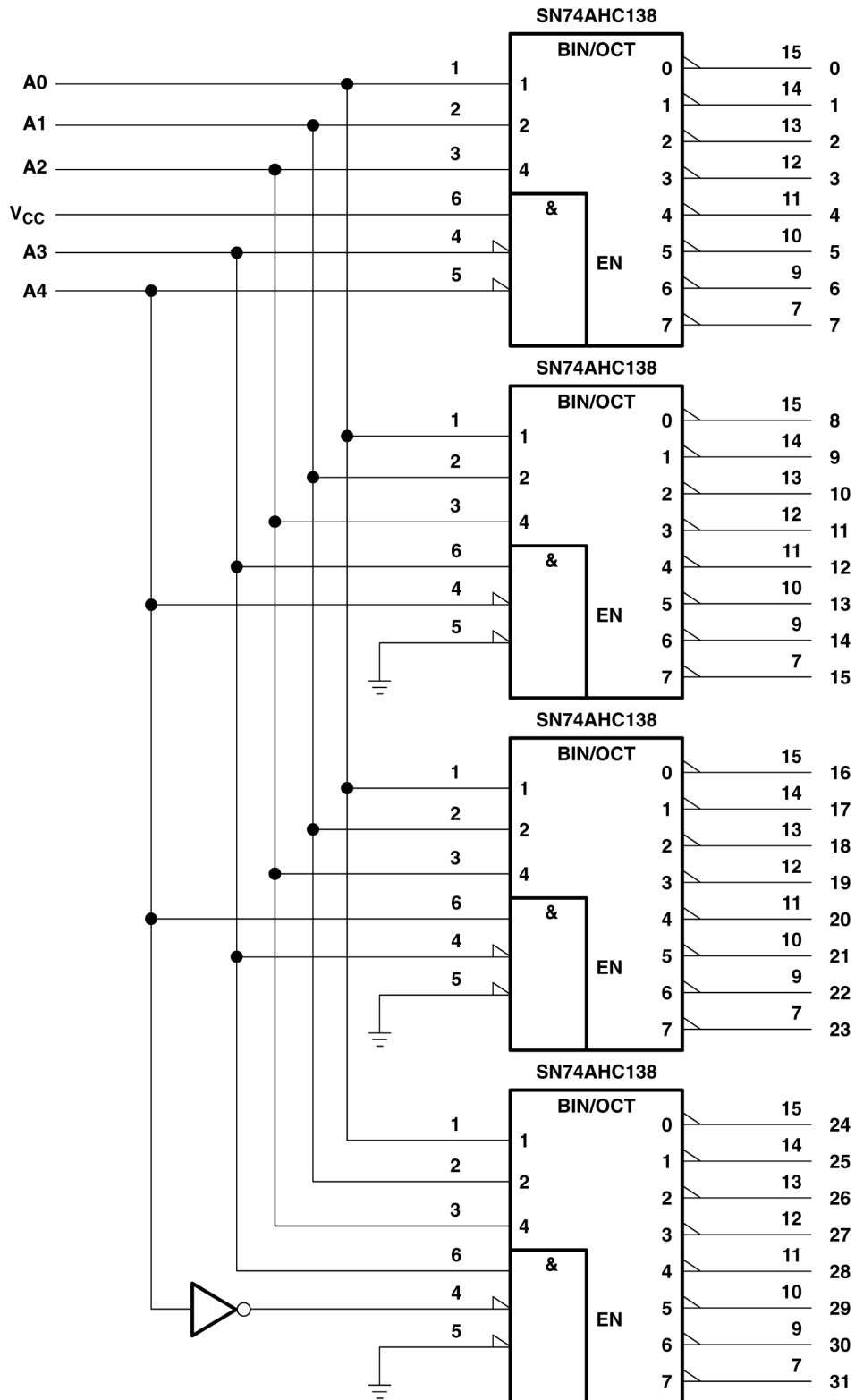
使用多输入和多通道逻辑器件时，输入不得悬空。在许多情况下，数字逻辑器件的功能或部分功能未被使用；例如，当仅使用三输入与门的两个输入或仅使用 4 个缓冲门中的 3 个时。此类未使用的输入引脚不得悬空，因为外部连接处的未定义电压会导致未定义的操作状态。数字逻辑器件的所有未使用输入必须连接到由输入电压规范定义的逻辑高电平电压或逻辑低电平电压，以防止其悬空。必须应用于任何特定未使用输入的逻辑电平取决于器件的功能。通常，输入连接到 GND 或 V_{CC} ，以对逻辑功能更有意义或更方便者为准。

7.3.2 布局示例



图 7-3. SN74AHC138 的示例布局

8 器件和文档支持

TI 提供广泛的开发工具。下面列出了用于评估器件性能、生成代码和开发解决方案的工具和软件。

8.1 文档支持 (模拟)

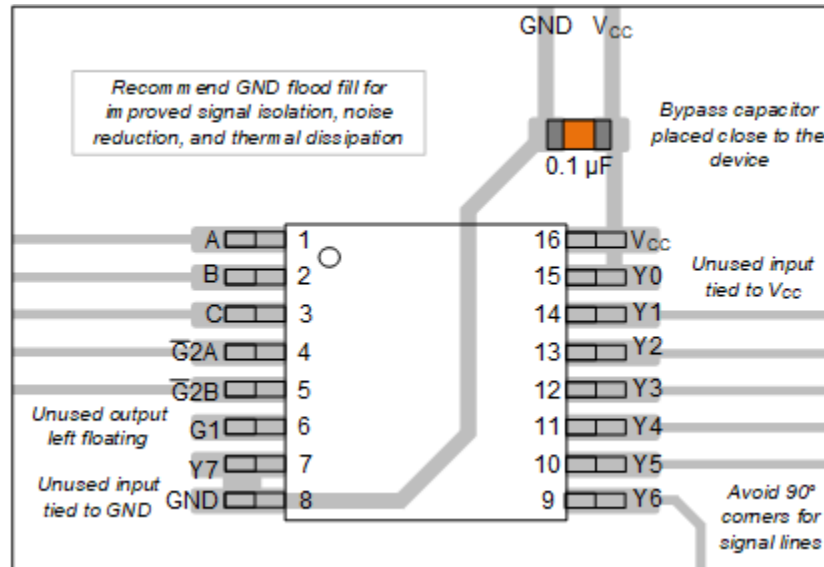
8.1.1 相关链接

下表列出了快速访问链接。类别包括技术文档、支持和社区资源、工具和软件，以及申请样片或购买产品的快速链接。

表 8-1. 相关链接

器件	产品文件夹	样片 & 购买	技术文档	工具 & 软件	支持 & 社区
SN54AHC138	点击此处	点击此处	点击此处	点击此处	点击此处
SN74AHC138	点击此处	点击此处	点击此处	点击此处	点击此处

8.2 接收文档更新通知

要接收文档更新通知，请导航至 ti.com 上的器件产品文件夹。点击 [通知](#) 进行注册，即可每周接收产品信息更改摘要。有关更改的详细信息，请查看任何已修订文档中包含的修订历史记录。

8.3 支持资源

[TI E2E™ 中文支持论坛](#) 是工程师的重要参考资料，可直接从专家处获得快速、经过验证的解答和设计帮助。搜索现有解答或提出自己的问题，获得所需的快速设计帮助。

链接的内容由各个贡献者“按原样”提供。这些内容并不构成 TI 技术规范，并且不一定反映 TI 的观点；请参阅 TI 的 [使用条款](#)。

8.4 商标

TI E2E™ is a trademark of Texas Instruments.

所有商标均为其各自所有者的财产。

8.5 静电放电警告



静电放电 (ESD) 会损坏这个集成电路。德州仪器 (TI) 建议通过适当的预防措施处理所有集成电路。如果不遵守正确的处理和安装程序，可能会损坏集成电路。

ESD 的损坏小至导致微小的性能降级，大至整个器件故障。精密的集成电路可能更容易受到损坏，这是因为非常细微的参数更改都可能会导致器件与其发布的规格不相符。

8.6 术语表

[TI 术语表](#) 本术语表列出并解释了术语、首字母缩略词和定义。

9 修订历史记录

注：以前版本的页码可能与当前版本的页码不同

Changes from Revision M (April 2024) to Revision N (July 2024) Page

- 将 D 封装的热性能指标 $R_{\theta JA}$ 的值从 73 更新为 93.8，所有值均以 °C/W 为单位.....6

Changes from Revision L (July 2003) to Revision M (April 2024) Page

- 添加了 [封装信息表](#)、[引脚功能表](#)、[ESD 等级表](#)、[热性能信息表](#)、[器件功能模式](#)、“应用和实施”部分、[器件和文档支持](#) 部分以及 [机械、封装和可订购信息](#) 部分.....1
- 删除了对机器放电模型的引用.....1

- 将 PW 封装的热性能指标 $R_{\theta JA}$ 的值从 108 更新为 135.9，所有值均以 $^{\circ}\text{C}/\text{W}$ 为单位..... 6
-

10 机械、封装和可订购信息

下述页面包含机械、封装和订购信息。这些信息是指定器件可用的最新数据。数据如有变更，恕不另行通知，且不会对此文档进行修订。有关此数据表的浏览器版本，请查阅左侧的导航栏。

PACKAGING INFORMATION

Orderable part number	Status (1)	Material type (2)	Package Pins	Package qty Carrier	RoHS (3)	Lead finish/ Ball material (4)	MSL rating/ Peak reflow (5)	Op temp (°C)	Part marking (6)
5962-9851601Q2A	Active	Production	LCCC (FK) 20	55 TUBE	No	SNPB	N/A for Pkg Type	-55 to 125	5962- 9851601Q2A SNJ54AHC 138FK
5962-9851601QEA	Active	Production	CDIP (J) 16	25 TUBE	No	SNPB	N/A for Pkg Type	-55 to 125	5962-9851601QE A SNJ54AHC138J
5962-9851601QFA	Active	Production	CFP (W) 16	25 TUBE	No	SNPB	N/A for Pkg Type	-55 to 125	5962-9851601QF A SNJ54AHC138W
SN74AHC138D	Obsolete	Production	SOIC (D) 16	-	-	Call TI	Call TI	-40 to 85	AHC138
SN74AHC138DBR	NRND	Production	SSOP (DB) 16	2000 LARGE T&R	Yes	NIPDAU	Level-1-260C-UNLIM	-40 to 85	HA138
SN74AHC138DBR.A	NRND	Production	SSOP (DB) 16	2000 LARGE T&R	Yes	NIPDAU	Level-1-260C-UNLIM	-40 to 85	HA138
SN74AHC138DGVR	NRND	Production	TVSOP (DGV) 16	2000 LARGE T&R	Yes	NIPDAU	Level-1-260C-UNLIM	-40 to 85	HA138
SN74AHC138DGVR.A	NRND	Production	TVSOP (DGV) 16	2000 LARGE T&R	Yes	NIPDAU	Level-1-260C-UNLIM	-40 to 85	HA138
SN74AHC138DR	Active	Production	SOIC (D) 16	2500 LARGE T&R	Yes	NIPDAU	Level-1-260C-UNLIM	-40 to 85	AHC138
SN74AHC138DR.A	Active	Production	SOIC (D) 16	2500 LARGE T&R	Yes	NIPDAU	Level-1-260C-UNLIM	-40 to 85	AHC138
SN74AHC138N	Active	Production	PDIP (N) 16	25 TUBE	Yes	NIPDAU	N/A for Pkg Type	-40 to 85	SN74AHC138N
SN74AHC138N.A	Active	Production	PDIP (N) 16	25 TUBE	Yes	NIPDAU	N/A for Pkg Type	-40 to 85	SN74AHC138N
SN74AHC138NSR	Active	Production	SOP (NS) 16	2000 LARGE T&R	Yes	NIPDAU	Level-1-260C-UNLIM	-40 to 85	AHC138
SN74AHC138NSR.A	Active	Production	SOP (NS) 16	2000 LARGE T&R	Yes	NIPDAU	Level-1-260C-UNLIM	-40 to 85	AHC138
SN74AHC138PW	Obsolete	Production	TSSOP (PW) 16	-	-	Call TI	Call TI	-40 to 85	HA138
SN74AHC138PWR	Active	Production	TSSOP (PW) 16	2000 LARGE T&R	Yes	NIPDAU SN	Level-1-260C-UNLIM	-40 to 85	HA138
SN74AHC138PWR.A	Active	Production	TSSOP (PW) 16	2000 LARGE T&R	Yes	NIPDAU	Level-1-260C-UNLIM	-40 to 85	HA138
SN74AHC138RGYR	NRND	Production	VQFN (RGY) 16	3000 LARGE T&R	Yes	NIPDAU	Level-2-260C-1 YEAR	-40 to 85	HA138
SN74AHC138RGYR.A	NRND	Production	VQFN (RGY) 16	3000 LARGE T&R	Yes	NIPDAU	Level-2-260C-1 YEAR	-40 to 85	HA138
SNJ54AHC138FK	Active	Production	LCCC (FK) 20	55 TUBE	No	SNPB	N/A for Pkg Type	-55 to 125	5962- 9851601Q2A SNJ54AHC 138FK

Orderable part number	Status (1)	Material type (2)	Package Pins	Package qty Carrier	RoHS (3)	Lead finish/ Ball material (4)	MSL rating/ Peak reflow (5)	Op temp (°C)	Part marking (6)
SNJ54AHC138FK.A	Active	Production	LCCC (FK) 20	55 TUBE	No	SNPB	N/A for Pkg Type	-55 to 125	5962- 9851601Q2A SNJ54AHC 138FK
SNJ54AHC138J	Active	Production	CDIP (J) 16	25 TUBE	No	SNPB	N/A for Pkg Type	-55 to 125	5962-9851601QE A SNJ54AHC138J
SNJ54AHC138J.A	Active	Production	CDIP (J) 16	25 TUBE	No	SNPB	N/A for Pkg Type	-55 to 125	5962-9851601QE A SNJ54AHC138J
SNJ54AHC138W	Active	Production	CFP (W) 16	25 TUBE	No	SNPB	N/A for Pkg Type	-55 to 125	5962-9851601QF A SNJ54AHC138W
SNJ54AHC138W.A	Active	Production	CFP (W) 16	25 TUBE	No	SNPB	N/A for Pkg Type	-55 to 125	5962-9851601QF A SNJ54AHC138W

(1) **Status:** For more details on status, see our [product life cycle](#).

(2) **Material type:** When designated, preproduction parts are prototypes/experimental devices, and are not yet approved or released for full production. Testing and final process, including without limitation quality assurance, reliability performance testing, and/or process qualification, may not yet be complete, and this item is subject to further changes or possible discontinuation. If available for ordering, purchases will be subject to an additional waiver at checkout, and are intended for early internal evaluation purposes only. These items are sold without warranties of any kind.

(3) **RoHS values:** Yes, No, RoHS Exempt. See the [TI RoHS Statement](#) for additional information and value definition.

(4) **Lead finish/Ball material:** Parts may have multiple material finish options. Finish options are separated by a vertical ruled line. Lead finish/Ball material values may wrap to two lines if the finish value exceeds the maximum column width.

(5) **MSL rating/Peak reflow:** The moisture sensitivity level ratings and peak solder (reflow) temperatures. In the event that a part has multiple moisture sensitivity ratings, only the lowest level per JEDEC standards is shown. Refer to the shipping label for the actual reflow temperature that will be used to mount the part to the printed circuit board.

(6) **Part marking:** There may be an additional marking, which relates to the logo, the lot trace code information, or the environmental category of the part.

Multiple part markings will be inside parentheses. Only one part marking contained in parentheses and separated by a "-" will appear on a part. If a line is indented then it is a continuation of the previous line and the two combined represent the entire part marking for that device.

Important Information and Disclaimer: The information provided on this page represents TI's knowledge and belief as of the date that it is provided. TI bases its knowledge and belief on information provided by third parties, and makes no representation or warranty as to the accuracy of such information. Efforts are underway to better integrate information from third parties. TI has taken and continues to take reasonable steps to provide representative and accurate information but may not have conducted destructive testing or chemical analysis on incoming materials and chemicals. TI and TI suppliers consider certain information to be proprietary, and thus CAS numbers and other limited information may not be available for release.

In no event shall TI's liability arising out of such information exceed the total purchase price of the TI part(s) at issue in this document sold by TI to Customer on an annual basis.

OTHER QUALIFIED VERSIONS OF SN54AHC138, SN74AHC138 :

- Catalog : [SN74AHC138](#)
- Automotive : [SN74AHC138-Q1](#), [SN74AHC138-Q1](#)
- Military : [SN54AHC138](#)

NOTE: Qualified Version Definitions:

- Catalog - TI's standard catalog product
- Automotive - Q100 devices qualified for high-reliability automotive applications targeting zero defects
- Military - QML certified for Military and Defense Applications

TAPE AND REEL INFORMATION

QUADRANT ASSIGNMENTS FOR PIN 1 ORIENTATION IN TAPE

*All dimensions are nominal

Device	Package Type	Package Drawing	Pins	SPQ	Reel Diameter (mm)	Reel Width W1 (mm)	A0 (mm)	B0 (mm)	K0 (mm)	P1 (mm)	W (mm)	Pin1 Quadrant
SN74AHC138DBR	SSOP	DB	16	2000	330.0	16.4	8.35	6.6	2.4	12.0	16.0	Q1
SN74AHC138DGVR	TVSOP	DGV	16	2000	330.0	12.4	6.8	4.0	1.6	8.0	12.0	Q1
SN74AHC138DR	SOIC	D	16	2500	330.0	16.4	6.5	10.3	2.1	8.0	16.0	Q1
SN74AHC138DR	SOIC	D	16	2500	330.0	12.4	3.75	3.75	1.15	8.0	12.0	Q1
SN74AHC138NSR	SOP	NS	16	2000	330.0	16.4	8.1	10.4	2.5	12.0	16.0	Q1
SN74AHC138PWR	TSSOP	PW	16	2000	330.0	12.4	6.9	5.6	1.6	8.0	12.0	Q1
SN74AHC138RGYR	VQFN	RGY	16	3000	330.0	12.4	3.8	4.3	1.5	8.0	12.0	Q1

TAPE AND REEL BOX DIMENSIONS

*All dimensions are nominal

Device	Package Type	Package Drawing	Pins	SPQ	Length (mm)	Width (mm)	Height (mm)
SN74AHC138DBR	SSOP	DB	16	2000	353.0	353.0	32.0
SN74AHC138DGVR	TVSOP	DGV	16	2000	353.0	353.0	32.0
SN74AHC138DR	SOIC	D	16	2500	353.0	353.0	32.0
SN74AHC138DR	SOIC	D	16	2500	340.5	336.1	32.0
SN74AHC138NSR	SOP	NS	16	2000	353.0	353.0	32.0
SN74AHC138PWR	TSSOP	PW	16	2000	353.0	353.0	32.0
SN74AHC138RGYR	VQFN	RGY	16	3000	353.0	353.0	32.0

TUBE

*All dimensions are nominal

Device	Package Name	Package Type	Pins	SPQ	L (mm)	W (mm)	T (μm)	B (mm)
5962-9851601Q2A	FK	LCCC	20	55	506.98	12.06	2030	NA
5962-9851601QFA	W	CFP	16	25	506.98	26.16	6220	NA
SN74AHC138N	N	PDIP	16	25	506	13.97	11230	4.32
SN74AHC138N	N	PDIP	16	25	506	13.97	11230	4.32
SN74AHC138N.A	N	PDIP	16	25	506	13.97	11230	4.32
SN74AHC138N.A	N	PDIP	16	25	506	13.97	11230	4.32
SNJ54AHC138FK	FK	LCCC	20	55	506.98	12.06	2030	NA
SNJ54AHC138FK.A	FK	LCCC	20	55	506.98	12.06	2030	NA
SNJ54AHC138W	W	CFP	16	25	506.98	26.16	6220	NA
SNJ54AHC138W.A	W	CFP	16	25	506.98	26.16	6220	NA

DGV (R-PDSO-G**)

PLASTIC SMALL-OUTLINE

24 PINS SHOWN



- NOTES: A. All linear dimensions are in millimeters.
 B. This drawing is subject to change without notice.
 C. Body dimensions do not include mold flash or protrusion, not to exceed 0,15 per side.
 D. Falls within JEDEC: 24/48 Pins – MO-153
 14/16/20/56 Pins – MO-194

W (R-GDFP-F16)

CERAMIC DUAL FLATPACK

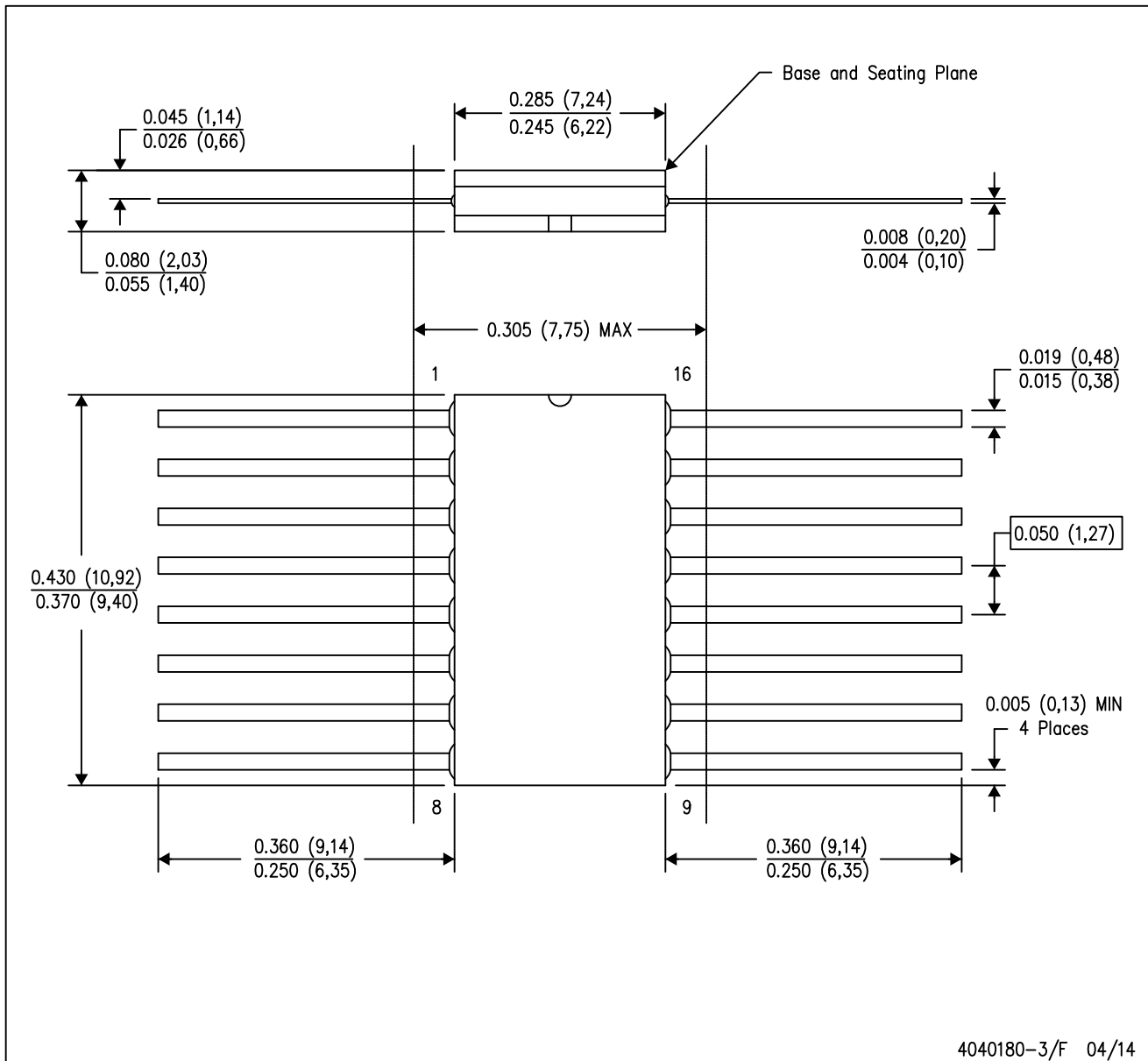

- NOTES:
- A. All linear dimensions are in inches (millimeters).
 - B. This drawing is subject to change without notice.
 - C. This package can be hermetically sealed with a ceramic lid using glass frit.
 - D. Index point is provided on cap for terminal identification only.
 - E. Falls within MIL STD 1835 GDFP2-F16

GENERIC PACKAGE VIEW

FK 20

LCCC - 2.03 mm max height

8.89 x 8.89, 1.27 mm pitch

LEADLESS CERAMIC CHIP CARRIER

This image is a representation of the package family, actual package may vary.
Refer to the product data sheet for package details.



4229370VA\

J (R-GDIP-T**)

14 LEADS SHOWN

CERAMIC DUAL IN-LINE PACKAGE



DIM \ PINS **	14	16	18	20
A	0.300 (7,62) BSC	0.300 (7,62) BSC	0.300 (7,62) BSC	0.300 (7,62) BSC
B MAX	0.785 (19,94)	.840 (21,34)	0.960 (24,38)	1.060 (26,92)
B MIN	—	—	—	—
C MAX	0.300 (7,62)	0.300 (7,62)	0.310 (7,87)	0.300 (7,62)
C MIN	0.245 (6,22)	0.245 (6,22)	0.220 (5,59)	0.245 (6,22)



4040083/F 03/03

- NOTES:
- All linear dimensions are in inches (millimeters).
 - This drawing is subject to change without notice.
 - This package is hermetically sealed with a ceramic lid using glass frit.
 - Index point is provided on cap for terminal identification only on press ceramic glass frit seal only.
 - Falls within MIL STD 1835 GDIP1-T14, GDIP1-T16, GDIP1-T18 and GDIP1-T20.



4220204/B 12/2023

NOTES:

1. All linear dimensions are in millimeters. Any dimensions in parenthesis are for reference only. Dimensioning and tolerancing per ASME Y14.5M.
2. This drawing is subject to change without notice.
3. This dimension does not include mold flash, protrusions, or gate burrs. Mold flash, protrusions, or gate burrs shall not exceed 0.15 mm per side.
4. This dimension does not include interlead flash. Interlead flash shall not exceed 0.25 mm per side.
5. Reference JEDEC registration MO-153.

EXAMPLE BOARD LAYOUT

PW0016A

TSSOP - 1.2 mm max height

SMALL OUTLINE PACKAGE



LAND PATTERN EXAMPLE
EXPOSED METAL SHOWN
SCALE: 10X



SOLDER MASK DETAILS

4220204/B 12/2023

NOTES: (continued)

- 6. Publication IPC-7351 may have alternate designs.
- 7. Solder mask tolerances between and around signal pads can vary based on board fabrication site.

EXAMPLE STENCIL DESIGN

PW0016A

TSSOP - 1.2 mm max height

SMALL OUTLINE PACKAGE



SOLDER PASTE EXAMPLE
BASED ON 0.125 mm THICK STENCIL
SCALE: 10X

4220204/B 12/2023

NOTES: (continued)

8. Laser cutting apertures with trapezoidal walls and rounded corners may offer better paste release. IPC-7525 may have alternate design recommendations.
9. Board assembly site may have different recommendations for stencil design.

N (R-PDIP-T**)

PLASTIC DUAL-IN-LINE PACKAGE

16 PINS SHOWN



- NOTES:
- A. All linear dimensions are in inches (millimeters).
 - B. This drawing is subject to change without notice.
 - Falls within JEDEC MS-001, except 18 and 20 pin minimum body length (Dim A).
 - The 20 pin end lead shoulder width is a vendor option, either half or full width.

RGY (R-PVQFN-N16)

PLASTIC QUAD FLATPACK NO-LEAD

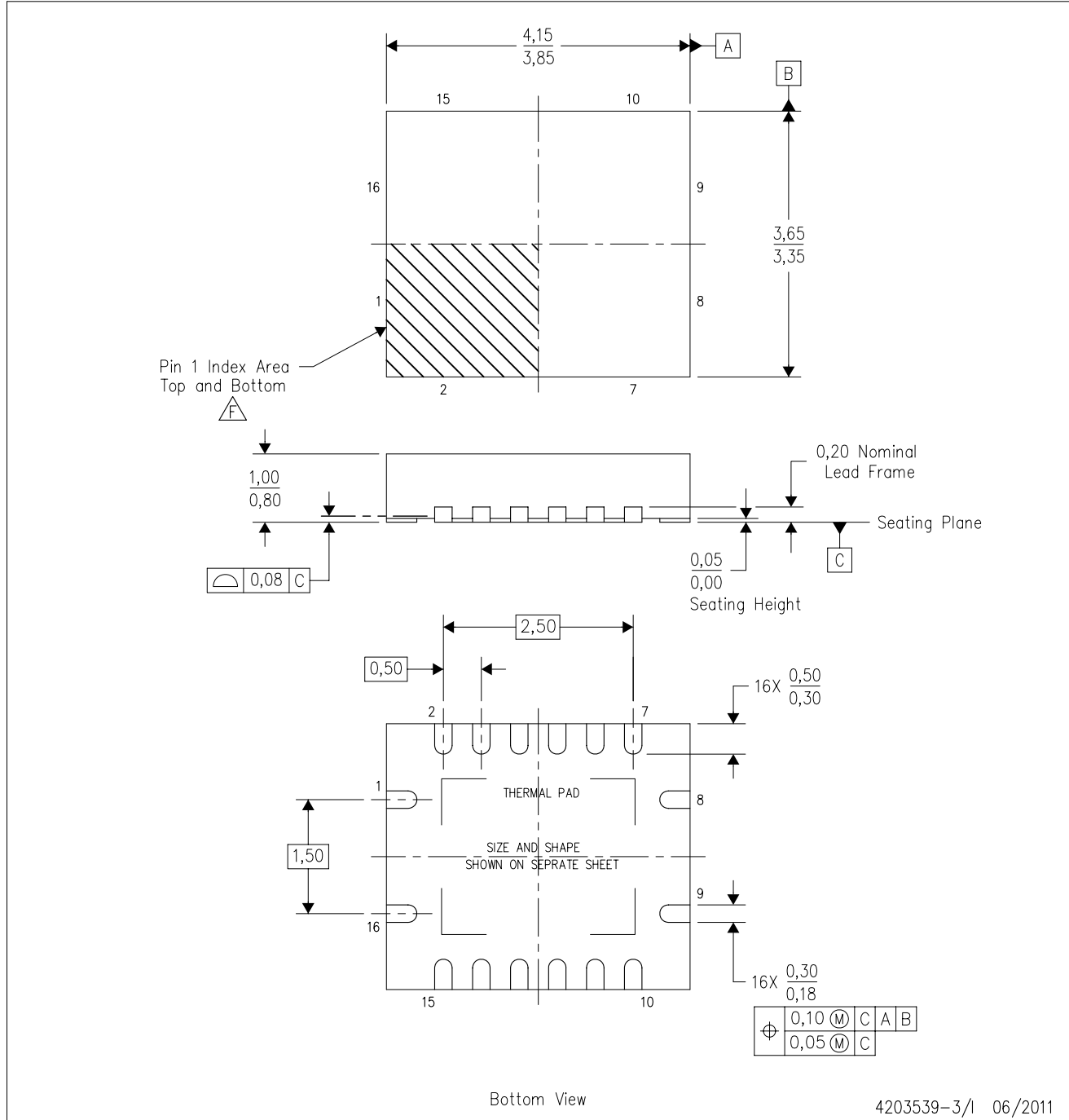

- NOTES:
- A. All linear dimensions are in millimeters. Dimensioning and tolerancing per ASME Y14.5M-1994.
 - B. This drawing is subject to change without notice.
 - C. QFN (Quad Flatpack No-Lead) package configuration.
 - D. The package thermal pad must be soldered to the board for thermal and mechanical performance.
 - E. See the additional figure in the Product Data Sheet for details regarding the exposed thermal pad features and dimensions.
 - F. Pin 1 identifiers are located on both top and bottom of the package and within the zone indicated. The Pin 1 identifiers are either a molded, marked, or metal feature.
 - G. Package complies to JEDEC MO-241 variation BA.

RGY (R-PVQFN-N16)

PLASTIC QUAD FLATPACK NO-LEAD

THERMAL INFORMATION

This package incorporates an exposed thermal pad that is designed to be attached directly to an external heatsink. The thermal pad must be soldered directly to the printed circuit board (PCB). After soldering, the PCB can be used as a heatsink. In addition, through the use of thermal vias, the thermal pad can be attached directly to the appropriate copper plane shown in the electrical schematic for the device, or alternatively, can be attached to a special heatsink structure designed into the PCB. This design optimizes the heat transfer from the integrated circuit (IC).

For information on the Quad Flatpack No-Lead (QFN) package and its advantages, refer to Application Report, QFN/SON PCB Attachment, Texas Instruments Literature No. SLUA271. This document is available at www.ti.com.

The exposed thermal pad dimensions for this package are shown in the following illustration.



Bottom View

Exposed Thermal Pad Dimensions

4206353-3/P 03/14

NOTE: All linear dimensions are in millimeters

RGY (R-PVQFN-N16)

PLASTIC QUAD FLATPACK NO-LEAD



4208122-3/P 03/14

- NOTES:
- A. All linear dimensions are in millimeters.
 - B. This drawing is subject to change without notice.
 - C. Publication IPC-7351 is recommended for alternate designs.
 - D. This package is designed to be soldered to a thermal pad on the board. Refer to Application Note, Quad Flat-Pack QFN/SON PCB Attachment, Texas Instruments Literature No. SLUA271, and also the Product Data Sheets for specific thermal information, via requirements, and recommended board layout. These documents are available at www.ti.com <<http://www.ti.com>>.
 - E. Laser cutting apertures with trapezoidal walls and also rounding corners will offer better paste release. Customers should contact their board assembly site for stencil design recommendations. Refer to IPC 7525 for stencil design considerations.
 - F. Customers should contact their board fabrication site for minimum solder mask web tolerances between signal pads.



PACKAGE OUTLINE

NS0016A

SOP - 2.00 mm max height

SOP

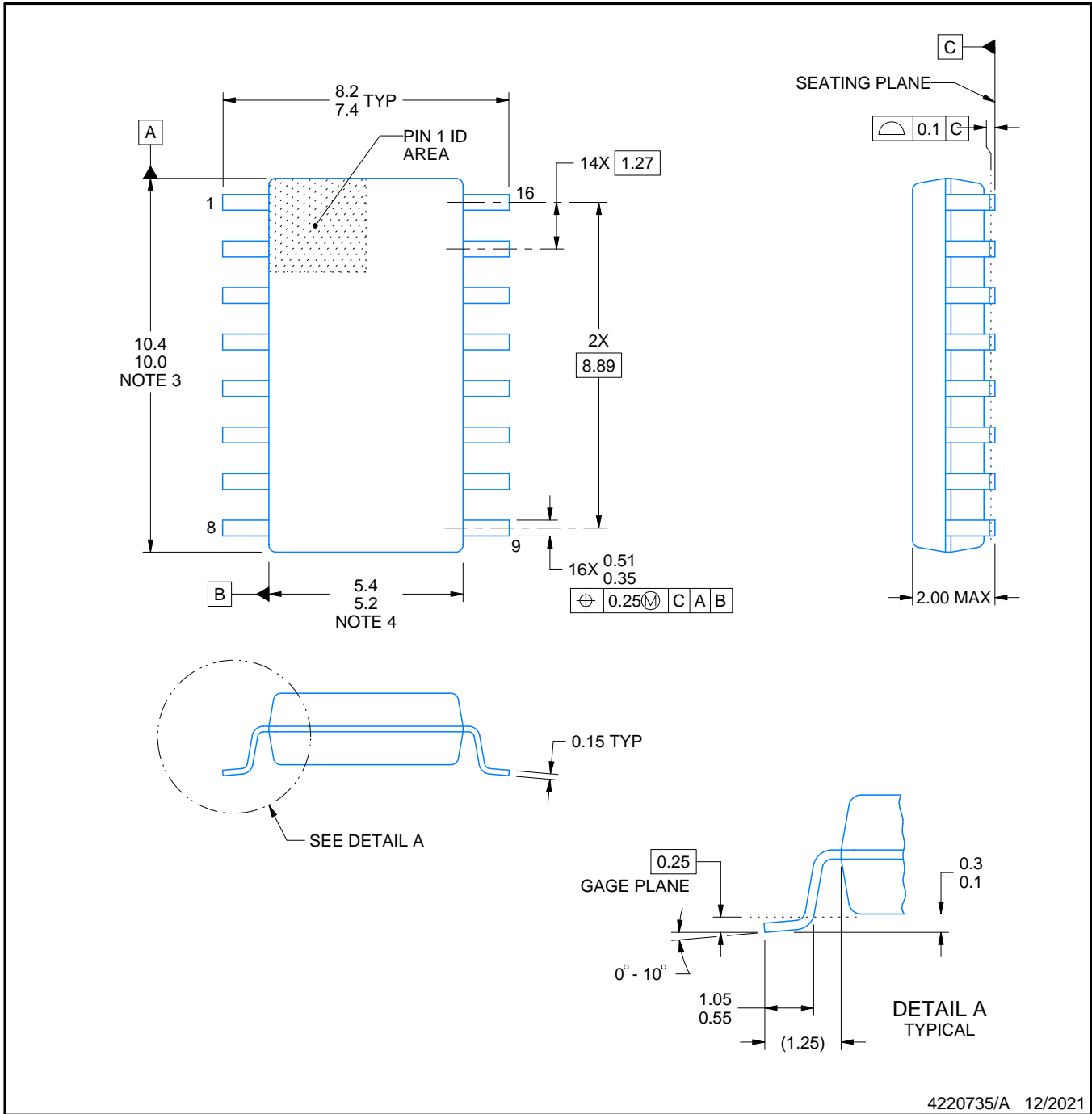

4220735/A 12/2021

NOTES:

1. All linear dimensions are in millimeters. Dimensions in parenthesis are for reference only. Dimensioning and tolerancing per ASME Y14.5M.
2. This drawing is subject to change without notice.
3. This dimension does not include mold flash, protrusions, or gate burrs. Mold flash, protrusions, or gate burrs shall not exceed 0.15 mm, per side.
4. This dimension does not include interlead flash. Interlead flash shall not exceed 0.25 mm, per side.

EXAMPLE BOARD LAYOUT

NS0016A

SOP - 2.00 mm max height

SOP



SOLDER MASK DETAILS

4220735/A 12/2021

NOTES: (continued)

5. Publication IPC-7351 may have alternate designs.

6. Solder mask tolerances between and around signal pads can vary based on board fabrication site.

EXAMPLE STENCIL DESIGN

NS0016A

SOP - 2.00 mm max height

SOP

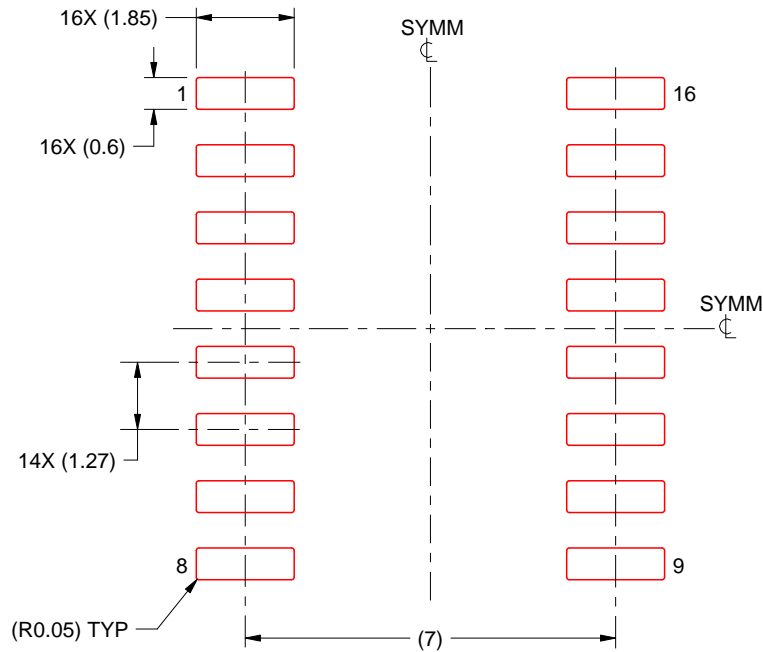

SOLDER PASTE EXAMPLE
BASED ON 0.125 mm THICK STENCIL
SCALE:7X

4220735/A 12/2021

NOTES: (continued)

7. Laser cutting apertures with trapezoidal walls and rounded corners may offer better paste release. IPC-7525 may have alternate design recommendations.
8. Board assembly site may have different recommendations for stencil design.

D (R-PDSO-G16)

PLASTIC SMALL OUTLINE



- NOTES:
- A. All linear dimensions are in inches (millimeters).
 - B. This drawing is subject to change without notice.
 - C. Body length does not include mold flash, protrusions, or gate burrs. Mold flash, protrusions, or gate burrs shall not exceed 0.006 (0,15) each side.
 - D. Body width does not include interlead flash. Interlead flash shall not exceed 0.017 (0,43) each side.
 - E. Reference JEDEC MS-012 variation AC.

DB0016A



PACKAGE OUTLINE

SSOP - 2 mm max height

SMALL OUTLINE PACKAGE

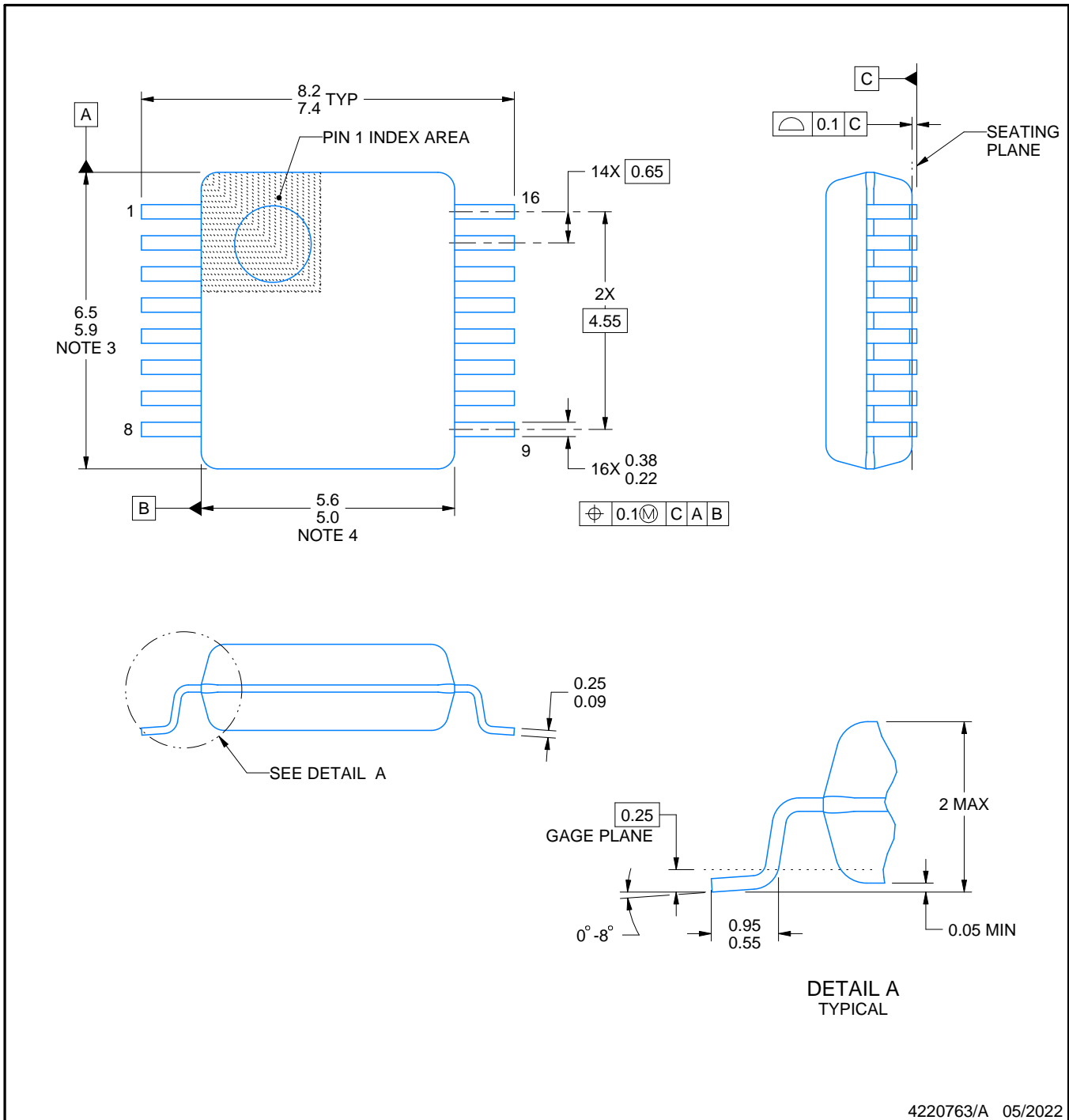

4220763/A 05/2022

NOTES:

- All linear dimensions are in millimeters. Any dimensions in parenthesis are for reference only. Dimensioning and tolerancing per ASME Y14.5M.
- This drawing is subject to change without notice.
- This dimension does not include mold flash, protrusions, or gate burrs. Mold flash, protrusions, or gate burrs shall not exceed 0.15 mm per side.
- Reference JEDEC registration MO-150.

EXAMPLE BOARD LAYOUT

DB0016A

SSOP - 2 mm max height

SMALL OUTLINE PACKAGE

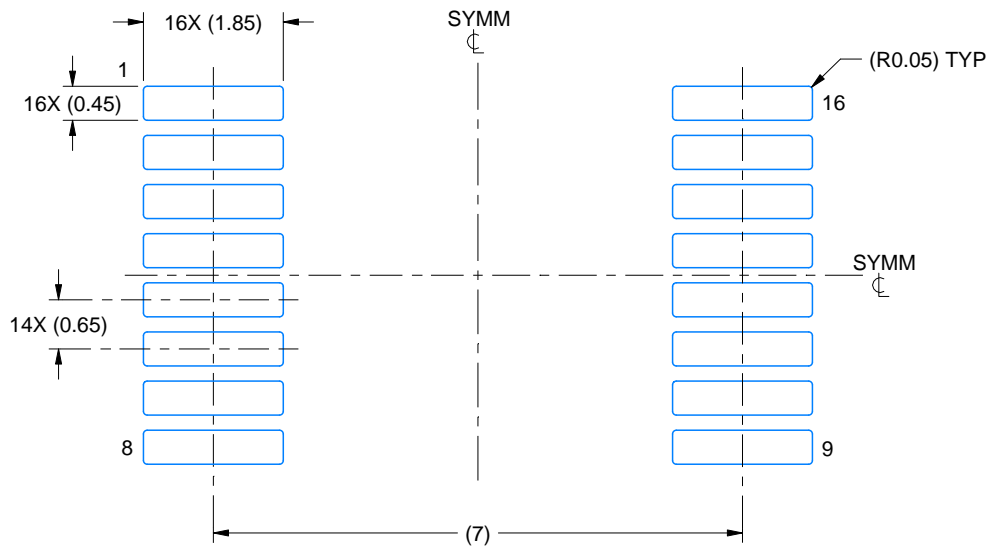

LAND PATTERN EXAMPLE
EXPOSED METAL SHOWN
SCALE: 10X

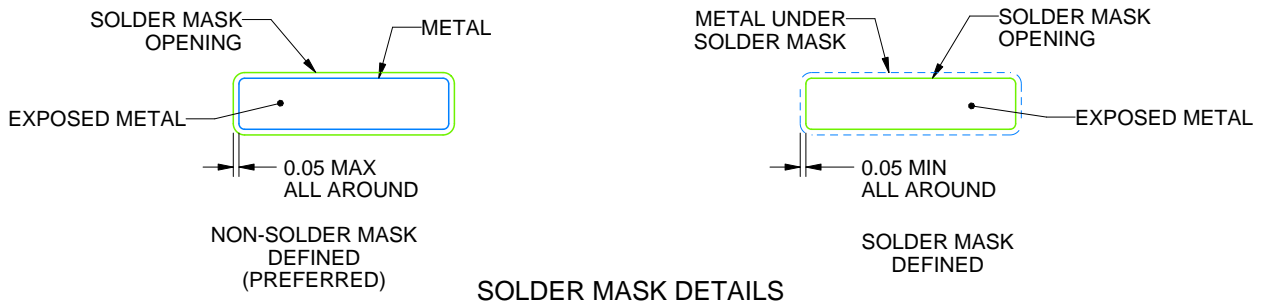

4220763/A 05/2022

NOTES: (continued)

5. Publication IPC-7351 may have alternate designs.
6. Solder mask tolerances between and around signal pads can vary based on board fabrication site.

EXAMPLE STENCIL DESIGN

DB0016A

SSOP - 2 mm max height

SMALL OUTLINE PACKAGE

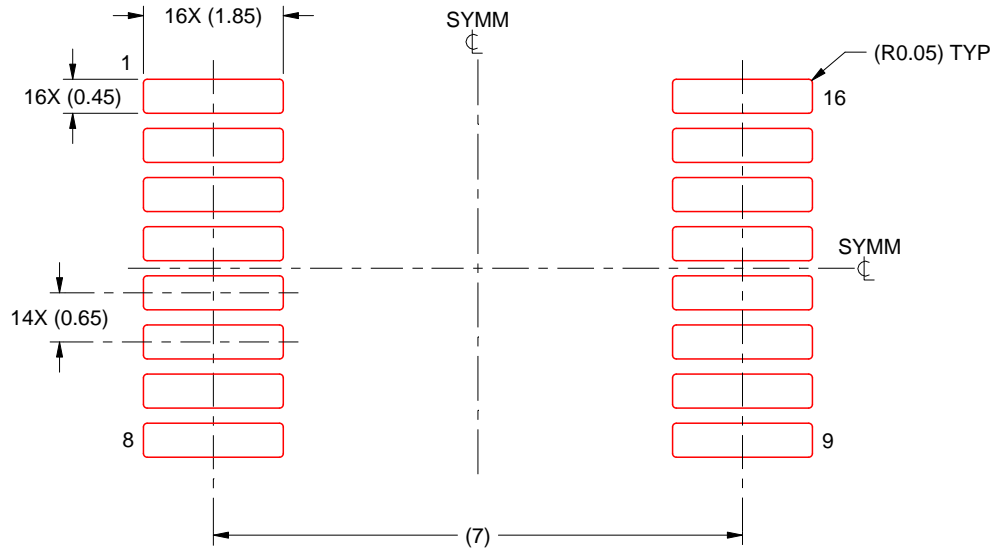

SOLDER PASTE EXAMPLE
BASED ON 0.125 mm THICK STENCIL
SCALE: 10X

4220763/A 05/2022

NOTES: (continued)

7. Laser cutting apertures with trapezoidal walls and rounded corners may offer better paste release. IPC-7525 may have alternate design recommendations.
8. Board assembly site may have different recommendations for stencil design.

重要通知和免责声明

TI“按原样”提供技术和可靠性数据（包括数据表）、设计资源（包括参考设计）、应用或其他设计建议、网络工具、安全信息和其他资源，不保证没有瑕疵且不做任何明示或暗示的担保，包括但不限于对适销性、与某特定用途的适用性或不侵犯任何第三方知识产权的暗示担保。

这些资源可供使用 TI 产品进行设计的熟练开发人员使用。您将自行承担以下全部责任：(1) 针对您的应用选择合适的 TI 产品，(2) 设计、验证并测试您的应用，(3) 确保您的应用满足相应标准以及任何其他安全、安保法规或其他要求。

这些资源如有变更，恕不另行通知。TI 授权您仅可将这些资源用于研发本资源所述的 TI 产品的相关应用。严禁以其他方式对这些资源进行复制或展示。您无权使用任何其他 TI 知识产权或任何第三方知识产权。对于因您对这些资源的使用而对 TI 及其代表造成的任何索赔、损害、成本、损失和债务，您将全额赔偿，TI 对此概不负责。

TI 提供的产品受 [TI 销售条款](#)、[TI 通用质量指南](#) 或 [ti.com](#) 上其他适用条款或 TI 产品随附的其他适用条款的约束。TI 提供这些资源并不会扩展或以其他方式更改 TI 针对 TI 产品发布的适用的担保或担保免责声明。除非德州仪器 (TI) 明确将某产品指定为定制产品或客户特定产品，否则其产品均为按确定价格收入目录的标准通用器件。

TI 反对并拒绝您可能提出的任何其他或不同的条款。

版权所有 © 2026，德州仪器 (TI) 公司

最后更新日期：2025 年 10 月