

# 具有 IEC ESD 保护功能的 SN65MLVD206B 多点 LVDS 线路驱动器和接收器（收发器）

## 1 特性

- 与 M-LVDS 标准 TIA/EIA-899 兼容，可进行多点数据交换
  - 低电压差分 30Ω 至 55Ω 线路驱动器和接收器，信号传输速率<sup>(1)</sup> 高达 200Mbps，时钟频率高达 100MHz
    - 2 类接收器的偏移阈值可检测开路和空闲总线状态
  - 总线 I/O 保护
    - ±8kV HBM
    - ±8kV IEC 61000-4-2 接触放电
  - 驱动器输出电压转换时间可控，可改善信号质量
  - -1V 至 3.4V 共模电压范围，可实现在 2V 接地噪声下进行数据传输
  - 总线引脚在禁用或  $V_{CC} \leq 1.5V$  时具有高阻抗
  - 提供 100Mbps 器件 (SN65MLVD204B)
  - SN65MLVD206 的改进备选器件
- <sup>(1)</sup> 线路的信号传输速率是指每秒钟的电压转换次数，单位为 bps（每秒比特数）

## 2 应用

- TIA/EIA-485 的低功耗、高速和短距备选器件
- 背板或电缆式多点数据和时钟传输
- [蜂窝基站](#)
- [局端交换机](#)
- [网络交换机和路由器](#)

## 3 说明

SN65MLVD206B 器件是一款多点低电压差分信号 (M-LVDS) 线路驱动器和接收器，经优化，能够以最高 200Mbps 的信号传输速率运行。该器件具有稳健耐用的 3.3V 驱动器和接收器，并且采用标准 SOIC 封装，适用于严苛的工业应用。总线引脚可耐受 ESD 事件，具有针对人体模型和 IEC 接触放电规范的高级保护。

该器件包含一个差分驱动器和一个差分接收器（收发器），由 3.3V 电源供电。该收发器经过优化，能够以最高 200Mbps 的信号传输速率运行。

SN65MLVD206B 较同类器件具有增强特性。这些增强特性包括驱动器输出端转换率可控，有助于尽量减少无端桩线的反射，从而提高信号完整性。沿用了相同尺寸，可轻松替换，有助于提升系统性能。这些器件的额定工作温度范围为 -40°C 至 85°C。

SN65MLVD206B M-LVDS 接收器是 TI 广泛的 [M-LVDS 产品系列](#) 器件。

### 器件信息<sup>(1)</sup>

器件型号	封装	封装尺寸（标称值）
SN65MLVD206B	SOIC (8)	4.90mm × 3.91mm

<sup>(1)</sup> 如需了解所有可用封装，请参阅数据表末尾的可订购产品附录。

### 简化原理图、SN65MLVD206B

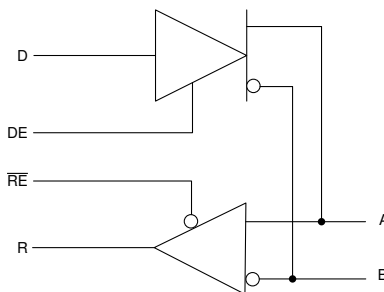

## 目录

<p>1 特性 ..... 1</p> <p>2 应用 ..... 1</p> <p>3 说明 ..... 1</p> <p>4 修订历史记录 ..... 2</p> <p>5 <b>Pin Configuration and Functions</b> ..... 3</p> <p>6 <b>Specifications</b> ..... 4</p> <p>    6.1 Absolute Maximum Ratings ..... 4</p> <p>    6.2 ESD Ratings ..... 4</p> <p>    6.3 Recommended Operating Conditions ..... 4</p> <p>    6.4 Thermal Information ..... 4</p> <p>    6.5 Electrical Characteristics ..... 5</p> <p>    6.6 Electrical Characteristics – Driver ..... 5</p> <p>    6.7 Electrical Characteristics – Receiver ..... 6</p> <p>    6.8 Electrical Characteristics – BUS Input and Output ... 6</p> <p>    6.9 Switching Characteristics – Driver ..... 7</p> <p>    6.10 Switching Characteristics – Receiver ..... 7</p> <p>    6.11 Typical Characteristics ..... 8</p> <p>7 <b>Parameter Measurement Information</b> ..... 8</p> <p>8 <b>Detailed Description</b> ..... 16</p>	<p>8.1 Overview ..... 16</p> <p>8.2 Functional Block Diagrams ..... 16</p> <p>8.3 Feature Description ..... 16</p> <p>8.4 Device Functional Modes ..... 17</p> <p>9 <b>Application and Implementation</b> ..... 19</p> <p>    9.1 Application Information ..... 19</p> <p>    9.2 Typical Application ..... 19</p> <p>10 <b>Power Supply Recommendations</b> ..... 24</p> <p>11 <b>Layout</b> ..... 24</p> <p>    11.1 Layout Guidelines ..... 24</p> <p>    11.2 Layout Example ..... 28</p> <p>12 <b>器件和文档支持</b> ..... 30</p> <p>    12.1 文档支持 ..... 30</p> <p>    12.2 接收文档更新通知 ..... 30</p> <p>    12.3 支持资源 ..... 30</p> <p>    12.4 商标 ..... 30</p> <p>    12.5 静电放电警告 ..... 30</p> <p>    12.6 Glossary ..... 30</p> <p>13 <b>机械、封装和可订购信息</b> ..... 30</p>
--	---

## 4 修订历史记录

Changes from Original (December 2016) to Revision A	Page
• 删除了文本、表格和图中关于器件 SN65MLVD201B、SN65MLVD203B 和 SN65MLVD207B 的所有引用	1
• 删除了“简化原理图”中的引脚编号。	1
• Deleted the D 14-Pin Package from the <i>Pin Configuration and Functions</i>	3
• Removed from Thermal Information 14-pin D, 201B, 203B, and 207B.	4
• Removed $I_{OZ}$ , $I_{O(OFF)}$ , $C_Y$ , $C_Z$ , $C_{YZ}$ , and $C_{Y/Z}$ in Driver Electrical Characteristics	5
• Removed Type-1 $V_{IT+}$ , $V_{IT-}$ , and $V_{HYS}$	6
• Removed $C_A$ , $C_B$ , $C_{AB}$ , and $C_{A/B}$ from Receiver Electrical Characteristics	6
• In the Bus Input and Output electrical characteristics, changed $C_A$ and $C_B$ from 5pF to 12pF.	6
• In the Bus Input and Output electrical characteristics, changed $C_{AB}$ from 4pF to 7pF.	6
• Changed the TYP value for $t_{r}$ , and $t_{f}$ , From: 2 ns To: 1.5 ns in the //Switching Characteristics – Driver// table	7
• Removed all "Y" and "Z" labels from the <i>Parameter Measurement Information</i> images	8
• Removed Type-1 Receiver Input Threshold Test Voltages table.	8
• Deleted "0.2 V Type 1" from Period Jitter in <a href="#">图 13</a>	15
• Removed Type-1 receivers exhibit 25 mV ... from Detailed Description Overview.	16
• Removed pin numbers from Functional Block Diagram	16
• Removed Table on Type-1 receiver	17
• Changed A/Y or B/Z to A or B in the Driver Output image	18
• Changed text From: "signal of 540 V" To: "signal of 540 mV" in the <i>Driver Output Voltage</i>	20

## 5 Pin Configuration and Functions

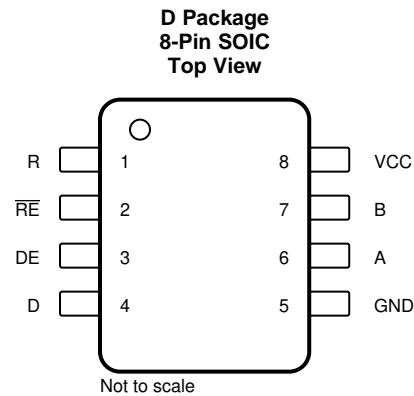

### Pin Functions

PIN		TYPE	DESCRIPTION
NAME	NO.		
A	6	I/O	Differential I/O
B	7	I/O	Differential I/O
D	4	Input	Driver input
DE	3	Input	Driver enable pin; High = Enable, Low = Disable
GND	5	Power	Supply ground
NC	—	NC	No internal connection
R	1	Output	Receiver output
$\overline{RE}$	2	Input	Receiver enable pin; High = Disable, Low = Enable
V <sub>CC</sub>	8	Power	Power supply, 3.3 V

## 6 Specifications

### 6.1 Absolute Maximum Ratings

over operating free-air temperature range (unless otherwise noted)<sup>(1)</sup>

		MIN	MAX	UNIT
Supply voltage range, $V_{CC}$ <sup>(2)</sup>		-0.5	4	V
Input voltage range	D, DE, $\overline{RE}$	-0.5	4	V
	A, B	-1.8	4	V
Output voltage range	R	-0.3	4	V
	A, B	-1.8	4	V
Continuous power dissipation		See the <a href="#">Thermal Information</a> table		
Storage temperature, $T_{stg}$		-65	150	°C

- (1) Stresses beyond those listed under *Absolute Maximum Ratings* may cause permanent damage to the device. These are stress ratings only, which do not imply functional operation of the device at these or any other conditions beyond those indicated under *Recommended Operating Conditions*. Exposure to absolute-maximum-rated conditions for extended periods may affect device reliability.
- (2) All voltage values, except differential I/O bus voltages, are with respect to network ground terminal.

### 6.2 ESD Ratings

				VALUE	UNIT
$V_{(ESD)}$	Electrostatic discharge	Contact discharge, per IEC 61000-4-2	A, and B	±8000	V
		Human body model (HBM), per ANSI/ESDA/JEDEC JS-001, all pins	A, and B	±8000	V
			All pins except A and B	±4000	V
		Charged device model (CDM), per JEDEC specification JESD22-C101, all pins	All pins	±1500	V

### 6.3 Recommended Operating Conditions

over operating free-air temperature range (unless otherwise noted)

		MIN	NOM	MAX	UNIT
$V_{CC}$	Supply voltage	3	3.3	3.6	V
$V_{IH}$	High-level input voltage	2		$V_{CC}$	V
$V_{IL}$	Low-level input voltage	0		0.8	V
	Voltage at any bus terminal $V_A$ or $V_B$	-1.4		3.8	V
$ V_{ID} $	Magnitude of differential input voltage			$V_{CC}$	V
$R_L$	Differential load resistance	30	50		Ω
$1/t_{UI}$	Signaling rate			200	Mbps
$T_A$	Operating free-air temperature in D package	-40		85	°C

### 6.4 Thermal Information

THERMAL METRIC <sup>(1)</sup>		SN65MLVD206B		UNIT
		D (SOIC)		
		8 PINS		
$R_{\theta JA}$	Junction-to-ambient thermal resistance	112.2		°C/W
$R_{\theta JC(top)}$	Junction-to-case (top) thermal resistance	56.7		
$R_{\theta JB}$	Junction-to-board thermal resistance	52.8		
$\Psi_{JT}$	Junction-to-top characterization parameter	10.3		
$\Psi_{JB}$	Junction-to-board characterization parameter	52.3		

- (1) For more information about traditional and new thermal metrics, see the [Semiconductor and IC Package Thermal Metrics](#) application report.

## 6.5 Electrical Characteristics

over recommended operating conditions (unless otherwise noted)<sup>(1)</sup>

PARAMETER		TEST CONDITIONS	MIN	TYP	MAX	UNIT	
I <sub>CC</sub>	Supply current	Driver only	RE and DE at V <sub>CC</sub> , R <sub>L</sub> = 50 Ω, All others open		13	22	mA
		Both disabled	RE at V <sub>CC</sub> , DE at 0 V, R <sub>L</sub> = No Load, All others open		1	4	
		Both enabled	RE at 0 V, DE at V <sub>CC</sub> , R <sub>L</sub> = 50 Ω, All others open		16	24	
		Receiver only	RE at 0 V, DE at 0 V, All others open		4	13	
P <sub>D</sub>	Device power dissipation	R <sub>L</sub> = 50 Ω, Input to D is a 50-MHz 50% duty cycle square wave, DE = high, RE = low, T <sub>A</sub> = 85°C			100	mW	

(1) All typical values are at 25°C and with a 3.3-V supply voltage.

## 6.6 Electrical Characteristics – Driver

over recommended operating conditions unless otherwise noted

PARAMETER		TEST CONDITIONS	MIN <sup>(1)</sup>	TYP <sup>(2)</sup>	MAX	UNIT
V <sub>AB</sub>	Differential output voltage magnitude <sup>(3)</sup>	See <a href="#">图 3</a>	480		650	mV
Δ V <sub>AB</sub>	Change in differential output voltage magnitude between logic states		-50		50	mV
V <sub>OS(SS)</sub>	Steady-state common-mode output voltage	See <a href="#">图 4</a>	0.8		1.2	V
ΔV <sub>OS(SS)</sub>	Change in steady-state common-mode output voltage between logic states		-50		50	mV
V <sub>OS(PP)</sub>	Peak-to-peak common-mode output voltage				150	mV
V <sub>A(OC)</sub>	Maximum steady-state open-circuit output voltage	See <a href="#">图 8</a>	0		2.4	V
V <sub>B(OC)</sub>	Maximum steady-state open-circuit output voltage		0		2.4	V
V <sub>P(H)</sub>	Voltage overshoot, low-to-high level output	See <a href="#">图 6</a>			1.2 V <sub>SS</sub>	V
V <sub>P(L)</sub>	Voltage overshoot, high-to-low level output		-0.2 V <sub>SS</sub>			V
I <sub>IH</sub>	High-level input current (D, DE)	V <sub>IH</sub> = 2 V to V <sub>CC</sub>	0		10	μA
I <sub>IL</sub>	Low-level input current (D, DE)	V <sub>IL</sub> = GND to 0.8 V	0		10	μA
I <sub>OS</sub>	Differential short-circuit output current magnitude	See <a href="#">图 5</a>			24	mA

(1) The algebraic convention in which the least positive (most negative) limit is designated as minimum is used in this data sheet.

(2) All typical values are at 25°C and with a 3.3-V supply voltage.

(3) Measurement equipment accuracy is 10 mV at -40°C

## 6.7 Electrical Characteristics – Receiver

over recommended operating conditions unless otherwise noted

PARAMETER			TEST CONDITIONS	MIN	TYP <sup>(1)</sup>	MAX	UNIT
$V_{IT+}$	Positive-going differential input voltage threshold <sup>(2)</sup>	Type 2	See 图 10 and 表 1			150	mV
$V_{IT-}$	Negative-going differential input voltage threshold <sup>(2)</sup>	Type 2			50		mV
$V_{HYS}$	Differential input voltage hysteresis, ( $V_{IT+} - V_{IT-}$ )	Type 2			0		mV
$V_{OH}$	High-level output voltage (R)		$I_{OH} = -8 \text{ mA}$	2.4			V
$V_{OL}$	Low-level output voltage (R)		$I_{OL} = 8 \text{ mA}$			0.4	V
$I_{IH}$	High-level input current ( $\overline{RE}$ )		$V_{IH} = 2 \text{ V to } V_{CC}$	-10		0	$\mu\text{A}$
$I_{IL}$	Low-level input current ( $\overline{RE}$ )		$V_{IL} = \text{GND to } 0.8 \text{ V}$	-10		0	$\mu\text{A}$
$I_{OZ}$	High-impedance output current (R)		$V_O = 0 \text{ V or } 3.6 \text{ V}$	-10		15	$\mu\text{A}$

(1) All typical values are at 25°C and with a 3.3-V supply voltage.

(2) Measurement equipment accuracy is 10 mV at -40°C

## 6.8 Electrical Characteristics – BUS Input and Output

over recommended operating conditions unless otherwise noted

PARAMETER		TEST CONDITIONS			MIN	TYP <sup>(1)</sup>	MAX	UNIT
$I_A$	Receiver or transceiver with driver disabled input current	$V_A = 3.8 \text{ V,}$	$V_B = 1.2 \text{ V,}$		0		32	$\mu\text{A}$
		$V_A = 0 \text{ V or } 2.4 \text{ V,}$	$V_B = 1.2 \text{ V}$		-20		20	
		$V_A = -1.4 \text{ V,}$	$V_B = 1.2 \text{ V}$		-32		0	
$I_B$	Receiver or transceiver with driver disabled input current	$V_B = 3.8 \text{ V,}$	$V_A = 1.2 \text{ V}$		0		32	$\mu\text{A}$
		$V_B = 0 \text{ V or } 2.4 \text{ V,}$	$V_A = 1.2 \text{ V}$		-20		20	
		$V_B = -1.4 \text{ V,}$	$V_A = 1.2 \text{ V}$		-32		0	
$I_{AB}$	Receiver or transceiver with driver disabled differential input current ( $I_A - I_B$ )	$V_A = V_B,$	$1.4 \leq V_A \leq 3.8 \text{ V}$		-4		4	$\mu\text{A}$
$I_{A(OFF)}$	Receiver or transceiver power-off input current	$V_A = 3.8 \text{ V,}$	$V_B = 1.2 \text{ V,}$	$0 \text{ V} \leq V_{CC} \leq 1.5 \text{ V}$	0		32	$\mu\text{A}$
		$V_A = 0 \text{ V or } 2.4 \text{ V,}$	$V_B = 1.2 \text{ V,}$	$0 \text{ V} \leq V_{CC} \leq 1.5 \text{ V}$	-20		20	
		$V_A = -1.4 \text{ V,}$	$V_B = 1.2 \text{ V,}$	$0 \text{ V} \leq V_{CC} \leq 1.5 \text{ V}$	-32		0	
$I_{B(OFF)}$	Receiver or transceiver power-off input current	$V_B = 3.8 \text{ V,}$	$V_A = 1.2 \text{ V,}$	$0 \text{ V} \leq V_{CC} \leq 1.5 \text{ V}$	0		32	$\mu\text{A}$
		$V_B = 0 \text{ V or } 2.4 \text{ V,}$	$V_A = 1.2 \text{ V,}$	$0 \text{ V} \leq V_{CC} \leq 1.5 \text{ V}$	-20		20	
		$V_B = -1.4 \text{ V,}$	$V_A = 1.2 \text{ V,}$	$0 \text{ V} \leq V_{CC} \leq 1.5 \text{ V}$	-32		0	
$I_{AB(OFF)}$	Receiver input or transceiver power-off differential input current ( $I_A - I_B$ )	$V_A = V_B, 0 \text{ V} \leq V_{CC} \leq 1.5 \text{ V, } -1.4 \leq V_A \leq 3.8 \text{ V}$			-4		4	$\mu\text{A}$
$C_A$	Transceiver with driver disabled input capacitance	$V_A = 0.4 \sin(30E6\pi t) + 0.5 \text{ V}^{(2)}, V_B = 1.2 \text{ V}$				12		pF
$C_B$	Transceiver with driver disabled input capacitance	$V_B = 0.4 \sin(30E6\pi t) + 0.5 \text{ V}^{(2)}, V_A = 1.2 \text{ V}$				12		pF
$C_{AB}$	Transceiver with driver disabled differential input capacitance	$V_{AB} = 0.4 \sin(30E6\pi t) \text{ V}^{(2)}$				7		pF
$C_{A/B}$	Transceiver with driver disabled input capacitance balance, ( $C_A/C_B$ )				0.99		1.01	pF

(1) All typical values are at 25°C and with a 3.3-V supply voltage.

(2) HP4194A impedance analyzer (or equivalent)

## 6.9 Switching Characteristics – Driver

over recommended operating conditions unless otherwise noted

PARAMETER		TEST CONDITIONS	MIN	TYP <sup>(1)</sup>	MAX	UNIT
$t_{pLH}$	Propagation delay time, low-to-high-level output	See <a href="#">图 6</a>	2	2.5	3.5	ns
$t_{pHL}$	Propagation delay time, high-to-low-level output		2	2.5	3.5	ns
$t_r$	Differential output signal rise time		1.5			ns
$t_f$	Differential output signal fall time		1.5			ns
$t_{sk(p)}$	Pulse skew ( $ t_{pHL} - t_{pLH} $ )		30	150		ps
$t_{sk(pp)}$	Part-to-part skew <sup>(2)</sup>				0.9	ns
$t_{jit(per)}$	Period jitter, rms (1 standard deviation) <sup>(3)</sup>	100-MHz clock input <sup>(4)</sup>		1	2	ps
$t_{jit(pp)}$	Peak-to-peak jitter <sup>(3)(5)</sup>	200 Mbps 2 <sup>15</sup> –1 PRBS input <sup>(6)</sup>		160	210	ps
$t_{PHZ}$	Disable time, high-level-to-high-impedance output	See <a href="#">图 7</a>		4	7	ns
$t_{PLZ}$	Disable time, low-level-to-high-impedance output			4	7	ns
$t_{PZH}$	Enable time, high-impedance-to-high-level output			4	7	ns
$t_{PZL}$	Enable time, high-impedance-to-low-level output			4	7	ns

(1) All typical values are at 25°C and with a 3.3-V supply voltage.

(2) Part-to-part skew is defined as the difference in propagation delays between two devices that operate at the same V/T conditions.

(3) Jitter is ensured by design and characterization. Stimulus jitter has been subtracted from the numbers.

(4)  $t_r = t_f = 0.5$  ns (10% to 90%), measured over 30K samples.

(5) Peak-to-peak jitter includes jitter due to pulse skew ( $t_{sk(p)}$ ).

(6)  $t_r = t_f = 0.5$  ns (10% to 90%), measured over 100K samples.

## 6.10 Switching Characteristics – Receiver

over recommended operating conditions unless otherwise noted

PARAMETER		TEST CONDITIONS	MIN	TYP <sup>(1)</sup>	MAX	UNIT
$t_{pLH}$	Propagation delay time, low-to-high-level output	$C_L = 15$ pF, See <a href="#">图 11</a>	2	6	10	ns
$t_{pHL}$	Propagation delay time, high-to-low-level output		2	6	10	ns
$t_r$	Output signal rise time				2.3	ns
$t_f$	Output signal fall time				2.3	ns
$t_{sk(p)}$	Pulse skew ( $ t_{pHL} - t_{pLH} $ )	Type 2 $C_L = 15$ pF, See <a href="#">图 11</a>		400	750	ps
$t_{sk(pp)}$	Part-to-part skew <sup>(2)</sup>	$C_L = 15$ pF, See <a href="#">图 11</a>			1	ns
$t_{jit(per)}$	Period jitter, rms (1 standard deviation) <sup>(3)</sup>	100-MHz clock input <sup>(4)</sup>		1		ps
$t_{jit(pp)}$	Peak-to-peak jitter <sup>(3)(5)</sup>	Type 2 200 Mbps 2 <sup>15</sup> –1 PRBS input <sup>(6)</sup>		35	650	ps
$t_{PHZ}$	Disable time, high-level-to-high-impedance output	See <a href="#">图 12</a>		6	10	ns
$t_{PLZ}$	Disable time, low-level-to-high-impedance output			6	10	ns
$t_{PZH}$	Enable time, high-impedance-to-high-level output			10	15	ns
$t_{PZL}$	Enable time, high-impedance-to-low-level output			10	15	ns

(1) All typical values are at 25°C and with a 3.3-V supply voltage.

(2) Part-to-part skew is defined as the difference in propagation delays between two devices that operate at the same V/T conditions.

(3) Jitter is ensured by design and characterization. Stimulus jitter has been subtracted from the numbers.

(4)  $V_{ID} = 400$  mV<sub>pp</sub>,  $V_{cm} = 1$  V,  $t_r = t_f = 0.5$  ns (10% to 90%), measured over 30K samples.

(5) Peak-to-peak jitter includes jitter due to pulse skew ( $t_{sk(p)}$ ).

(6)  $V_{ID} = 400$  mV<sub>pp</sub>,  $V_{cm} = 1$  V,  $t_r = t_f = 0.5$  ns (10% to 90%), measured over 100K samples.

### 6.11 Typical Characteristics

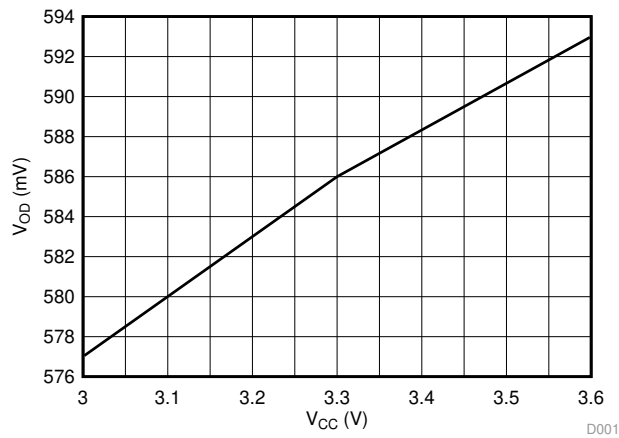

T<sub>A</sub> = 25°C

图 1. Differential Output Voltage vs Supply Voltage

## 7 Parameter Measurement Information

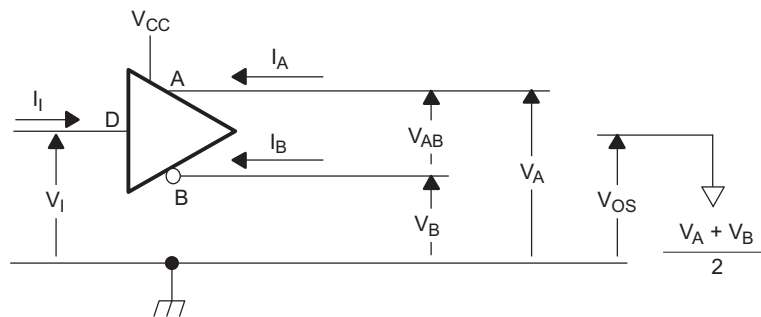

Copyright © 2016, Texas Instruments Incorporated

图 2. Driver Voltage and Current Definitions

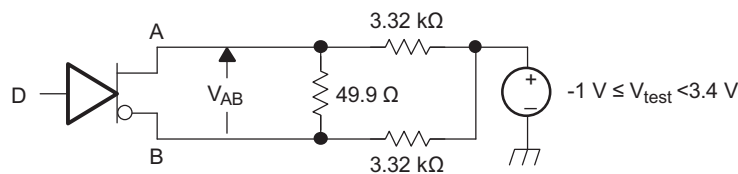

Copyright © 2016, Texas Instruments Incorporated

A. All resistors are 1% tolerance.

图 3. Differential Output Voltage Test Circuit



Parameter Measurement Information (接下页)

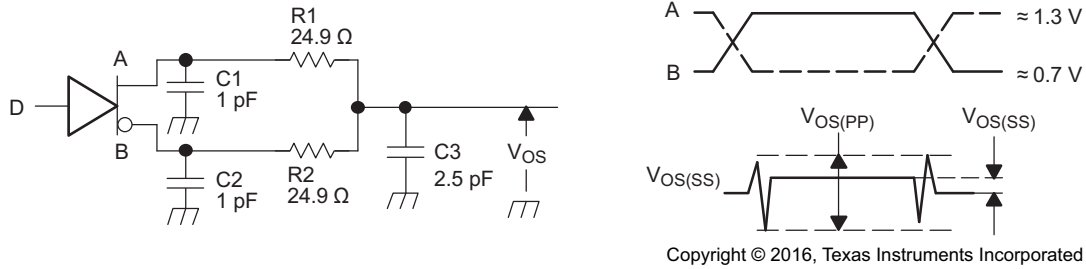

- A. All input pulses are supplied by a generator having the following characteristics:  $t_r$  or  $t_f \leq 1$  ns, pulse frequency = 1 MHz, duty cycle =  $50 \pm 5\%$ .
- B. C1, C2 and C3 include instrumentation and fixture capacitance within 2 cm of the D.U.T. and are  $\pm 20\%$ .
- C. R1 and R2 are metal film, surface mount,  $\pm 1\%$ , and located within 2 cm of the D.U.T.
- D. The measurement of  $V_{OS(PP)}$  is made on test equipment with a -3 dB bandwidth of at least 1 GHz.

图 4. Test Circuit and Definitions for the Driver Common-Mode Output Voltage



图 5. Driver Short-Circuit Test Circuit

**Parameter Measurement Information (接下页)**

- A. All input pulses are supplied by a generator having the following characteristics:  $t_r$  or  $t_f \leq 1\text{ ns}$ , frequency = 1 MHz, duty cycle =  $50 \pm 5\%$ .
- B. C1, C2, and C3 include instrumentation and fixture capacitance within 2 cm of the D.U.T. and are  $\pm 20\%$ .
- C. R1 is a metal film, surface mount, and 1% tolerance and located within 2 cm of the D.U.T.
- D. The measurement is made on test equipment with a -3 dB bandwidth of at least 1 GHz.

**图 6. Driver Test Circuit, Timing, and Voltage Definitions for the Differential Output Signal**

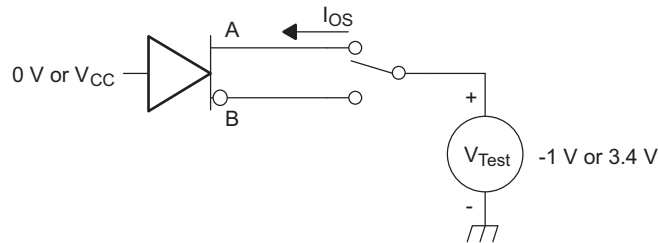
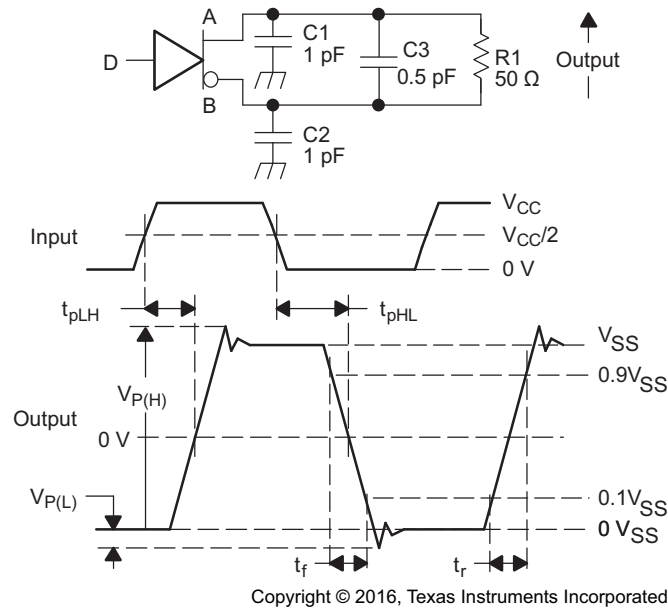
Parameter Measurement Information (接下页)

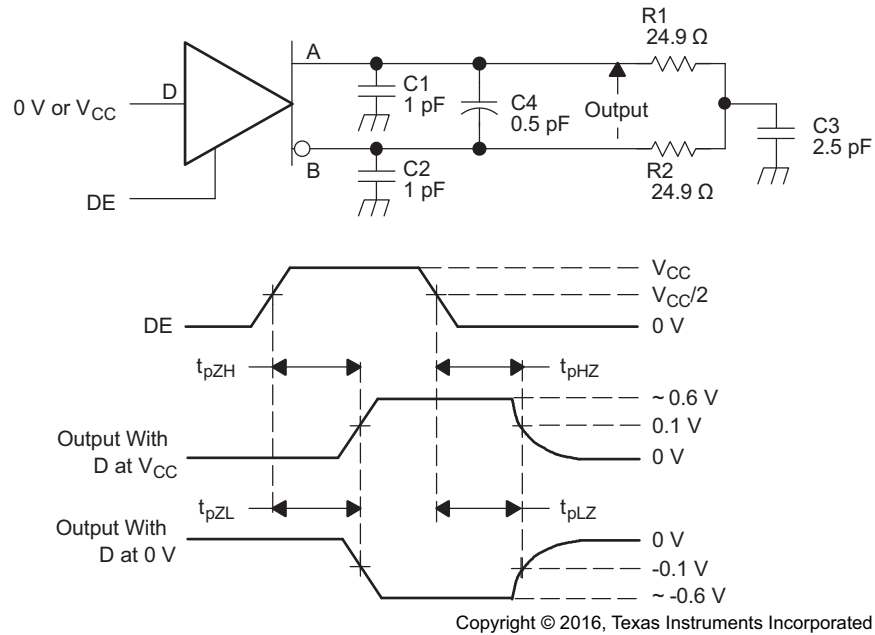

Copyright © 2016, Texas Instruments Incorporated

- A. All input pulses are supplied by a generator having the following characteristics:  $t_r$  or  $t_f \leq 1$  ns, frequency = 1 MHz, duty cycle = 50 ± 5%.
- B. C1, C2, C3, and C4 includes instrumentation and fixture capacitance within 2 cm of the D.U.T. and are ±20%.
- C. R1 and R2 are metal film, surface mount, and 1% tolerance and located within 2 cm of the D.U.T.
- D. The measurement is made on test equipment with a -3 dB bandwidth of at least 1 GHz.

图 7. Driver Enable and Disable Time Circuit and Definitions

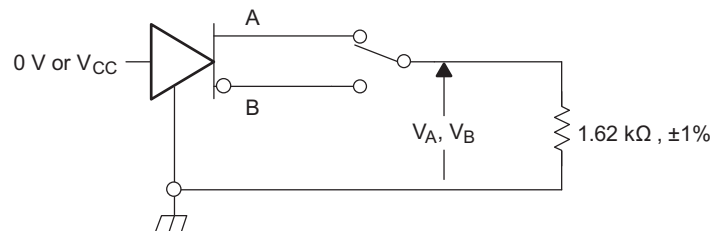

Copyright © 2016, Texas Instruments Incorporated

图 8. Maximum Steady State Output Voltage

**Parameter Measurement Information (接下页)**

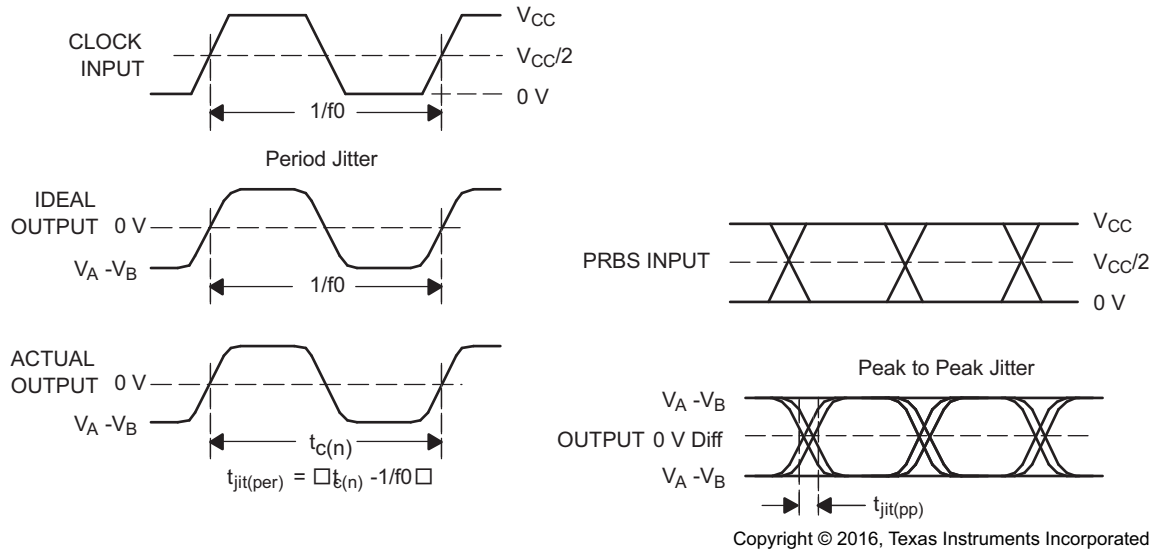

- A. All input pulses are supplied by an Agilent 81250 Stimulus System.
- B. The measurement is made on a TEK TDS6604 running TDSJIT3 application software
- C. Period jitter is measured using a 100 MHz 50 ±1% duty cycle clock input.
- D. Peak-to-peak jitter is measured using a 200 Mbps 2<sup>15</sup>-1 PRBS input.

**图 9. Driver Jitter Measurement Waveforms**

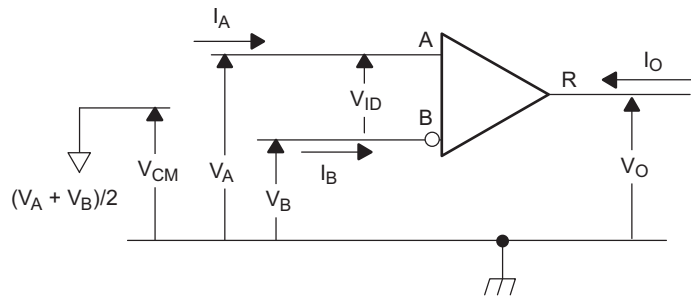

Copyright © 2016, Texas Instruments Incorporated

**图 10. Receiver Voltage and Current Definitions**

**表 1. Type-2 Receiver Input Threshold Test Voltages**

APPLIED VOLTAGES		RESULTING DIFFERENTIAL INPUT VOLTAGE	RESULTING COMMON-MODE INPUT VOLTAGE	RECEIVER OUTPUT <sup>(1)</sup>
VA	VB	VID	VIC	
2.400	0.000	2.400	1.200	H
0.000	2.400	-2.400	1.200	L
3.475	3.325	0.150	3.4	H
3.425	3.375	0.050	3.4	L
-0.925	-1.075	0.150	-1	H
-0.975	-1.025	0.050	-1	L

(1) H= high level, L = low level, output state assumes receiver is enabled ( $\overline{RE} = L$ )

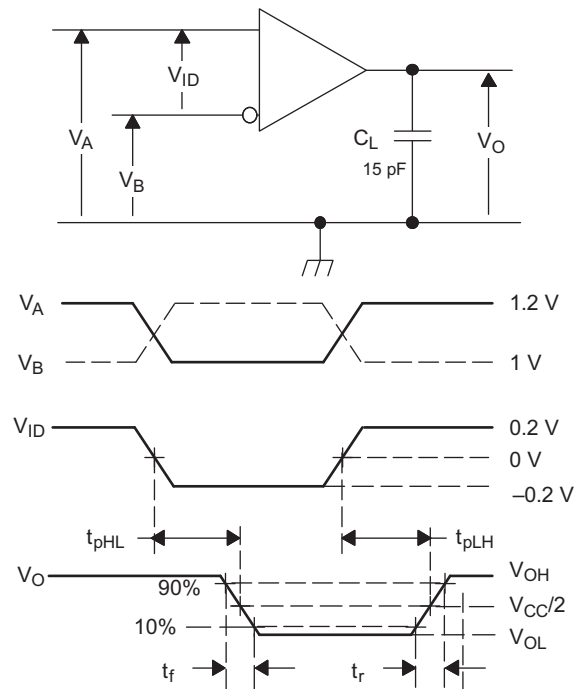

- A. All input pulses are supplied by a generator having the following characteristics:  $t_r$  or  $t_f \leq 1$  ns, frequency = 1 MHz, duty cycle =  $50 \pm 5\%$ .  $C_L$  is a combination of a 20%-tolerance, low-loss ceramic, surface-mount capacitor and fixture capacitance within 2 cm of the D.U.T.
- B. The measurement is made on test equipment with a  $-3$  dB bandwidth of at least 1 GHz.

图 11. Receiver Timing Test Circuit and Waveforms

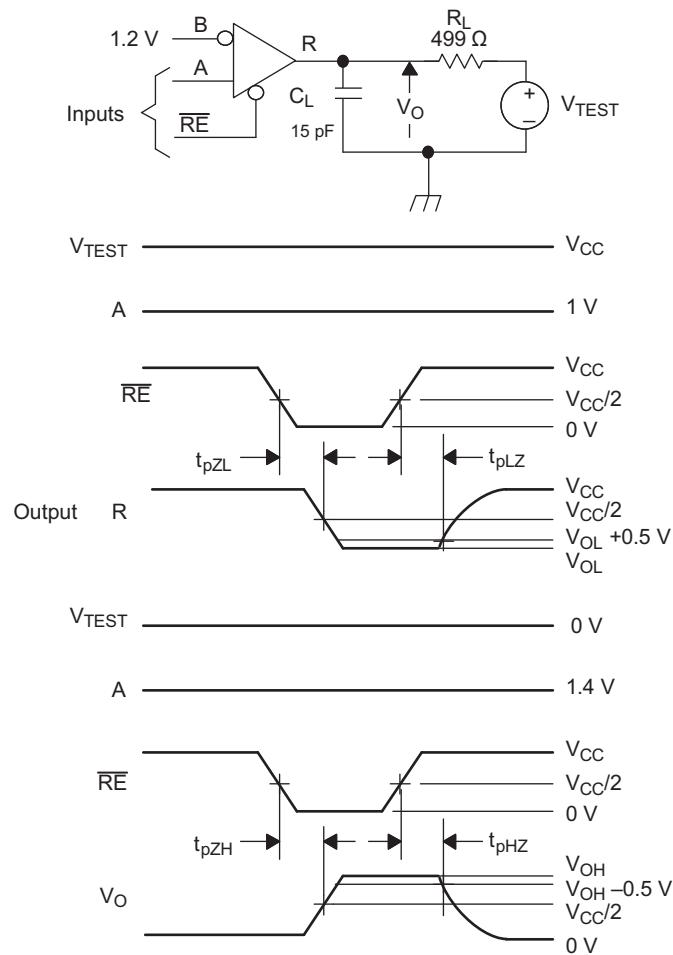

- A. All input pulses are supplied by a generator having the following characteristics:  $t_r$  or  $t_f \leq 1$  ns, frequency = 1 MHz, duty cycle =  $50 \pm 5\%$ .
- B.  $R_L$  is 1% tolerance, metal film, surface mount, and located within 2 cm of the D.U.T.
- C.  $C_L$  is the instrumentation and fixture capacitance within 2 cm of the DUT and  $\pm 20\%$ .

**图 12. Receiver Enable and Disable Time Test Circuit and Waveforms**

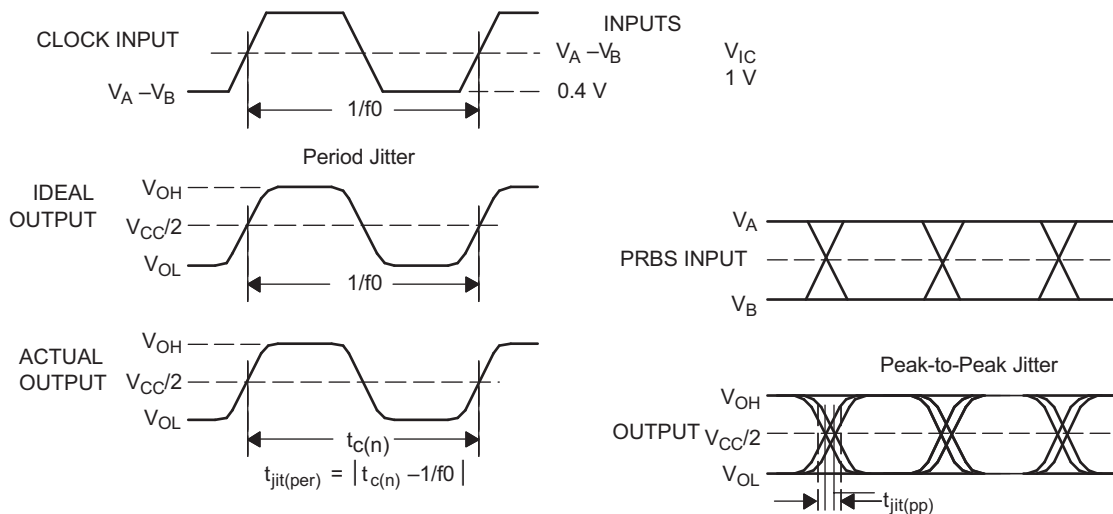

- A. All input pulses are supplied by an Agilent 8304A Stimulus System.
- B. The measurement is made on a TEK TDS6604 running TDSJIT3 application software
- C. Period jitter is measured using a 10 MHz 50  $\pm$ 1% duty cycle clock input.
- D. Peak-to-peak jitter is measured using a 200 Mbps  $2^{15}$ -1 PRBS input.

图 13. Receiver Jitter Measurement Waveforms

## 8 Detailed Description

### 8.1 Overview

The SN65MLVD206B is a multipoint-low-voltage differential (M-LVDS) line driver and receiver, which is optimized to operate at signaling rates up to 200 Mbps. The device complies with the multipoint low-voltage differential signaling (M-LVDS) standard TIA/EIA-899. This circuit is similar to the TIA/EIA-644 standard compliant LVDS counterpart, with added features to address multipoint applications. The driver output has been designed to support multipoint buses presenting loads as low as 30  $\Omega$ , and incorporates controlled transition times to allow for stubs off of the backbone transmission line.

The SN65MLVD206B has a Type-2 receiver that detects the bus state with as little as 50 mV of differential input voltage over a common-mode voltage range of  $-1$  V to 3.4 V. Type-2 receivers include an offset threshold to provide a known output state under open-circuit, idle-bus, and other fault conditions. Type-2 receivers include an offset threshold to provide a known output state under open-circuit, idle-bus, and other fault conditions.

### 8.2 Functional Block Diagrams



图 14. SN65MLVD206B Block Diagram

### 8.3 Feature Description

#### 8.3.1 Power-On-Reset

The SN65MLVD206B operates and meets all the specified performance requirements for supply voltages in the range of 3 V to 3.6 V. When the supply voltage drops below 1.5 V (or is turning on and has not yet reached 1.5 V), power-on reset circuitry sets the driver output to a high-impedance state.

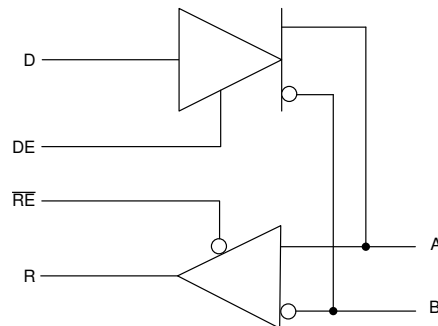
#### 8.3.2 ESD Protection

The bus terminals of the SN65MLVD206B possess on-chip ESD protection against  $\pm 8$ -kV human body model (HBM) and  $\pm 8$ -kV IEC61000-4-2 contact discharge. The IEC-ESD test is far more severe than the HBM-ESD test. The 50% higher charge capacitance, CS, and 78% lower discharge resistance,  $R_D$  of the IEC model produce significantly higher discharge currents than the HBM-model.

As stated in the IEC 61000-4-2 standard, contact discharge is the preferred test method; although IEC air-gap testing is less repeatable than contact testing, air discharge protection levels are inferred from the contact discharge test results.



Feature Description (接下页)

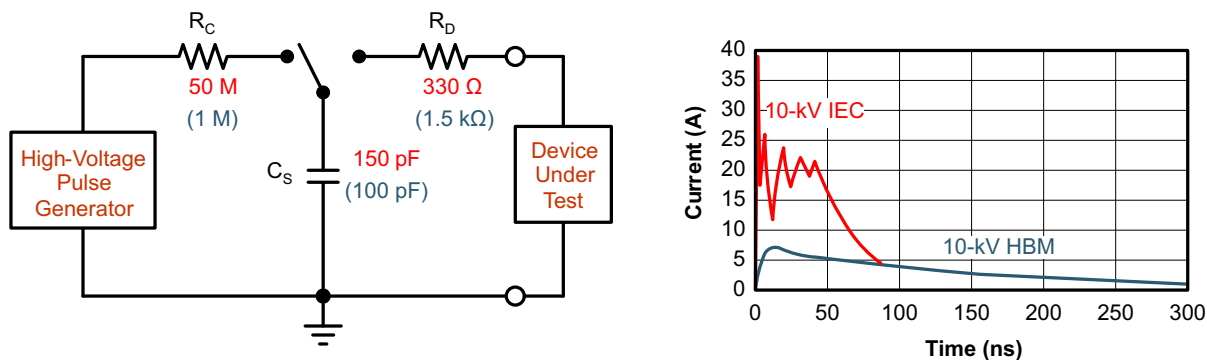

Copyright © 2016, Texas Instruments Incorporated

图 15. HBM and IEC-ESD Models and Currents in Comparison (HBM Values in Parenthesis)

8.4 Device Functional Modes

8.4.1 Operation with  $V_{CC} < 1.5 V$

Bus pins are high impedance under this condition.

8.4.2 Operations with  $1.5 V \leq V_{CC} < 3 V$

Operation with supply voltages in the range of  $1.5 V \leq V_{CC} < 3 V$  is undefined and no specific device performance is guaranteed in this range.

8.4.3 Operation with  $3 V \leq V_{CC} < 3.6 V$

Operation with the supply voltages greater than or equal to 3 V and less than or equal to 3.6 V is normal operation.

8.4.4 Device Function Tables

表 2. Type-2 Receiver<sup>(1)</sup>

INPUTS		OUTPUT
$V_{ID} = V_A - V_B$	$\overline{RE}$	R
$V_{ID} \geq 50 mV$	L	H
$50 mV < V_{ID} < 50 mV$	L	?
$V_{ID} \leq -50 mV$	L	L
X	H	Z
X	Open	Z

(1) H = high level, L = low level, Z = high impedance, X = Don't care, ? - indeterminate

表 3. Driver<sup>(1)</sup>

INPUTS	ENABLE	OUTPUTS	
D	DE	A	B
L	H	L	H
H	H	H	L
Open	H	L	H
X	Open	Z	Z
X	L	Z	Z

(1) H = high level, L = low level, Z = high impedance, X = Don't care, ? - indeterminate

SN65MLVD206B

ZHCSFW6A – DECEMBER 2016 – REVISED FEBRUARY 2020

www.ti.com.cn

8.4.5 Equivalent Input and Output Schematic Diagrams

DRIVER INPUT AND DRIVER ENABLE

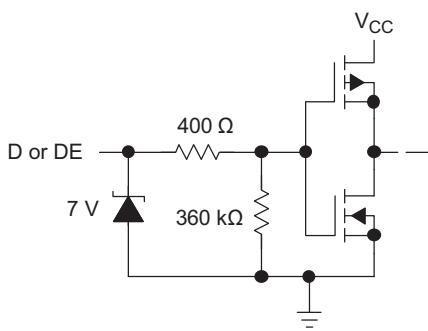

DRIVER OUTPUT

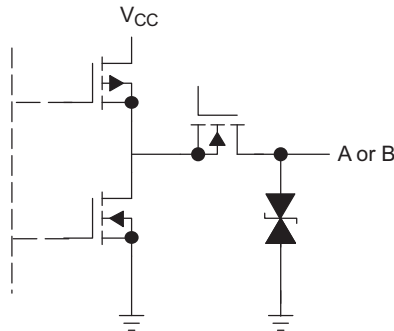

RECEIVER ENABLE

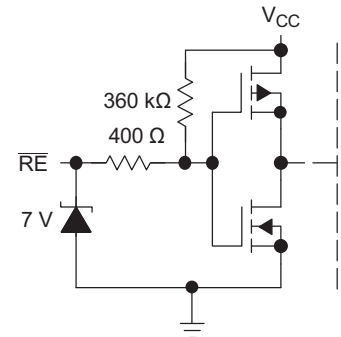

RECEIVER INPUT

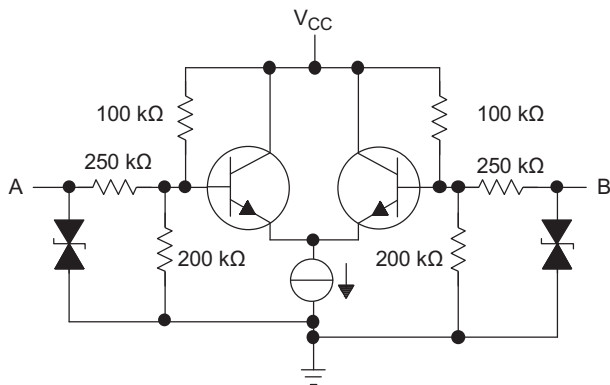

RECEIVER OUTPUT

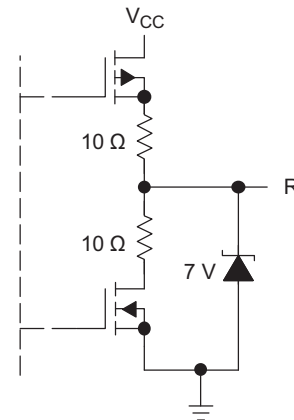

Copyright © 2016, Texas Instruments Incorporated

## 9 Application and Implementation

### 注

Information in the following applications sections is not part of the TI component specification, and TI does not warrant its accuracy or completeness. TI's customers are responsible for determining suitability of components for their purposes. Customers should validate and test their design implementation to confirm system functionality.

### 9.1 Application Information

The SN65MLVD206B is a multipoint line driver and receiver. The functionality of the device is simple, yet extremely flexible, leading to their use in designs ranging from wireless base stations to desktop computers.

### 9.2 Typical Application

#### 9.2.1 Multipoint Communications

In a multipoint configuration many transmitters and many receivers can be interconnected on a single transmission line. The key difference compared to multi-drop is the presence of two or more drivers. Such a situation creates contention issues that need not be addressed with point-to-point or multidrop systems. Multipoint operation allows for bidirectional, half-duplex communication over a single balanced media pair. To support the location of the various drivers throughout the transmission line, double termination of the transmission line is now necessary.

The major challenge that system designers encounter are the impedance discontinuities that device loading and device connections (stubs) introduce on the common bus. Matching the impedance of the loaded bus and using signal drivers with controlled signal edges are the keys to error-free signal transmissions in multipoint topologies.



图 16. Multipoint Configuration

#### 9.2.2 Design Requirements

For this design example, use the parameters listed in 表 4.

表 4. Design Parameters

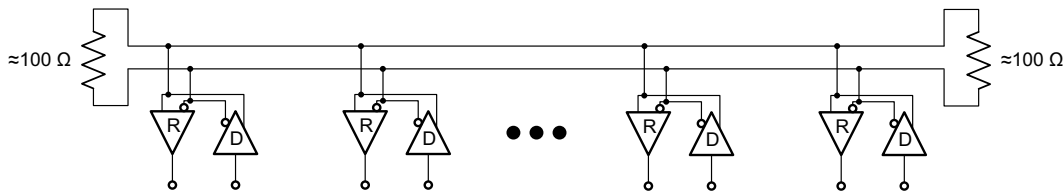
PARAMETERS	VALUES
Driver supply voltage	3 to 3.6 V
Driver input voltage	0.8 to 3.3 V
Driver signaling rate	DC to 200 Mbps
Interconnect characteristic impedance	100 $\Omega$
Termination resistance (differential)	100 $\Omega$
Number of receiver nodes	2 to 32
Receiver supply voltage	3 to 3.6 V
Receiver input voltage	0 to ( $V_{CC} - 0.8$ ) V
Receiver signaling rate	DC to 200 Mbps
Ground shift between driver and receiver	$\pm 1$ V

## 9.2.3 Detailed Design Procedure

### 9.2.3.1 Supply Voltage

The SN65MLVD206B is operated from a single supply. The device can support operations with a supply as low as 3 V and as high as 3.6 V.

### 9.2.3.2 Supply Bypass Capacitance

Bypass capacitors play a key role in power distribution circuitry. At low frequencies, power supply offers very low-impedance paths between its terminals. However, as higher frequency currents propagate through power traces, the source is often incapable of maintaining a low-impedance path to ground. Bypass capacitors are used to address this shortcoming. Usually, large bypass capacitors (10  $\mu\text{F}$  to 1000  $\mu\text{F}$ ) at the board level do a good job up into the kHz range. Due to their size and length of their leads, large capacitors tend to have large inductance values at the switching frequencies. To solve this problem, smaller capacitors (in the nF to  $\mu\text{F}$  range) must be installed locally next to the integrated circuit.

Multilayer ceramic chip or surface-mount capacitors (size 0603 or 0805) minimize lead inductances of bypass capacitors in high-speed environments, because their lead inductance is about 1 nH. For comparison purposes, a typical capacitor with leads has a lead inductance around 5 nH.

The value of the bypass capacitors used locally with M-LVDS chips can be determined by [公式 1](#) and [公式 2](#), according to *High Speed Digital Design – A Handbook of Black Magic* by Howard Johnson and Martin Graham (1993). A conservative rise time of 4 ns and a worst-case change in supply current of 100 mA covers the whole range of M-LVDS devices offered by Texas Instruments. In this example, the maximum power supply noise tolerated is 100 mV; however, this figure varies depending on the noise budget available for the design.

$$C_{\text{chip}} = \left( \frac{\Delta I_{\text{Maximum Step Change Supply Current}}}{\Delta V_{\text{Maximum Power Supply Noise}}} \right) \times T_{\text{Rise Time}} \quad (1)$$

$$C_{\text{MLVDS}} = \left( \frac{100 \text{ mA}}{100 \text{ mV}} \right) \times 4 \text{ ns} = 0.004 \mu\text{F} \quad (2)$$

[图 17](#) shows a configuration that lowers lead inductance and covers intermediate frequencies between the board-level capacitor (>10  $\mu\text{F}$ ) and the value of capacitance found above (0.004  $\mu\text{F}$ ). Place the smallest value of capacitance as close as possible to the chip.



**图 17. Recommended M-LVDS Bypass Capacitor Layout**

### 9.2.3.3 Driver Input Voltage

The input stage accepts LVTTTL signals. The driver operates with a decision threshold of approximately 1.4 V.

### 9.2.3.4 Driver Output Voltage

The driver outputs a steady state common mode voltage of 1 V with a differential signal of 540 mV under nominal conditions.

### 9.2.3.5 Termination Resistors

As shown earlier, an M-LVDS communication channel employs a current source driving a transmission line which is terminated with two resistive loads. These loads serve to convert the transmitted current into a voltage at the receiver input. To ensure good signal integrity, the termination resistors should be matched to the characteristic impedance of the transmission line. The designer should ensure that the termination resistors are within 10% of the nominal media characteristic impedance. If the transmission line is targeted for 100-Ω impedance, the termination resistors should be between 90 Ω and 110 Ω. The line termination resistors are typically placed at the ends of the transmission line.

### 9.2.3.6 Receiver Input Signal

The M-LVDS receivers herein comply with the M-LVDS standard and correctly determine the bus state. These devices have Type-1 and Type-2 receivers that detect the bus state with as little as 50 mV of differential voltage over the common mode range of -1 V to 3.4 V.

### 9.2.3.7 Receiver Input Threshold (Failsafe)

The MLVDS standard defines a Type-1 and Type-2 receiver. Type-1 receivers have their differential input voltage thresholds near zero volts. Type-2 receivers have their differential input voltage thresholds offset from 0 V to detect the absence of a voltage difference. The impact to receiver output by the offset input can be seen in 表 5 and 图 18.

表 5. Receiver Input Voltage Threshold Requirements

RECEIVER TYPE	OUTPUT LOW	OUTPUT HIGH
Type 1	$-2.4\text{ V} \leq V_{ID} \leq -0.05\text{ V}$	$0.05\text{ V} \leq V_{ID} \leq 2.4\text{ V}$
Type 2	$-2.4\text{ V} \leq V_{ID} \leq 0.05\text{ V}$	$0.15\text{ V} \leq V_{ID} \leq 2.4\text{ V}$



图 18. Expanded Graph of Receiver Differential Input Voltage Showing Transition Region

### 9.2.3.8 Receiver Output Signal

Receiver outputs comply with LVTTTL output voltage standards when the supply voltage is within the range of 3 V to 3.6 V.

### 9.2.3.9 Interconnecting Media

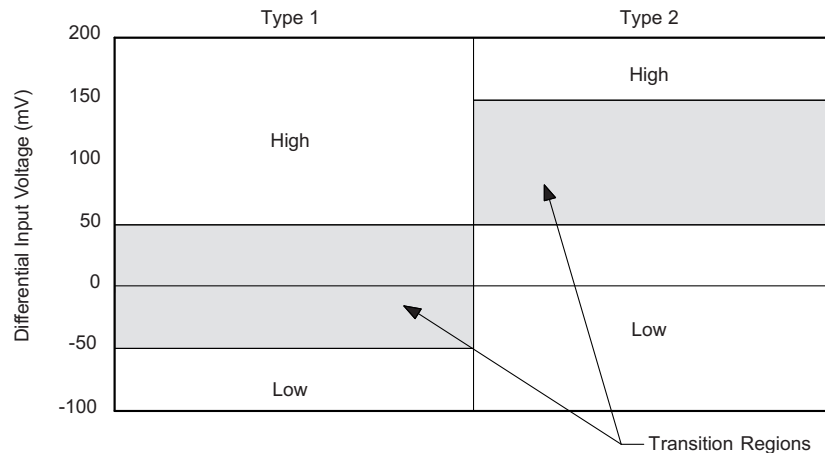
The physical communication channel between the driver and the receiver may be any balanced paired metal conductors meeting the requirements of the M-LVDS standard, the key points which will be included here. This media may be a twisted pair, twinax, flat ribbon cable, or PCB traces.

The nominal characteristic impedance of the interconnect should be between 100 Ω and 120 Ω with variation no more than 10% (90 Ω to 132 Ω).

### 9.2.3.10 PCB Transmission Lines

As per SNLA187, 图 19 depicts several transmission line structures commonly used in printed-circuit boards (PCBs). Each structure consists of a signal line and a return path with uniform cross-section along its length. A microstrip is a signal trace on the top (or bottom) layer, separated by a dielectric layer from its return path in a ground or power plane. A stripline is a signal trace in the inner layer, with a dielectric layer in between a ground plane above and below the signal trace. The dimensions of the structure along with the dielectric material properties determine the characteristic impedance of the transmission line (also called controlled-impedance transmission line).

When two signal lines are placed close by, they form a pair of coupled transmission lines. 图 19 shows examples of edge-coupled microstrips, and edge-coupled or broad-side-coupled striplines. When excited by differential signals, the coupled transmission line is referred to as a differential pair. The characteristic impedance of each line is called odd-mode impedance. The sum of the odd-mode impedances of each line is the differential impedance of the differential pair. In addition to the trace dimensions and dielectric material properties, the spacing between the two traces determines the mutual coupling and impacts the differential impedance. When the two lines are immediately adjacent; for example, if  $S$  is less than  $2 \times W$ , the differential pair is called a tightly-coupled differential pair. To maintain constant differential impedance along the length, it is important to keep the trace width and spacing uniform along the length, as well as maintain good symmetry between the two lines.

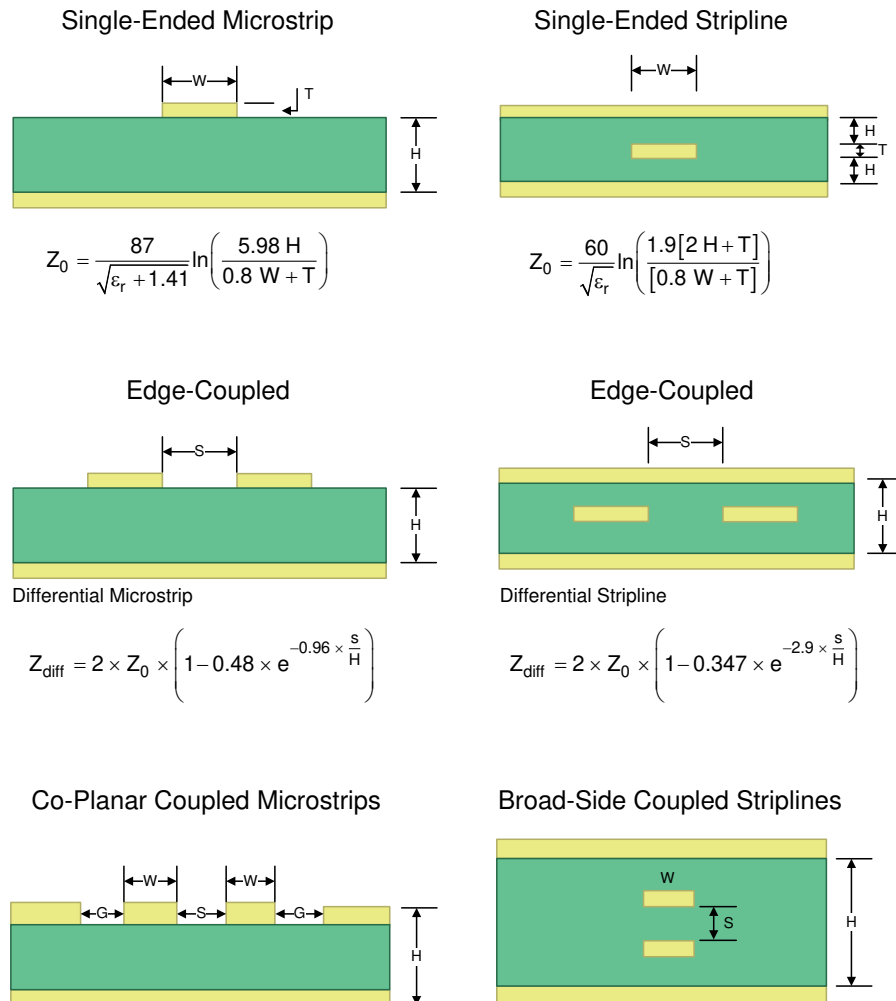

**图 19. Controlled-Impedance Transmission Lines**

### 9.2.4 Application Curves

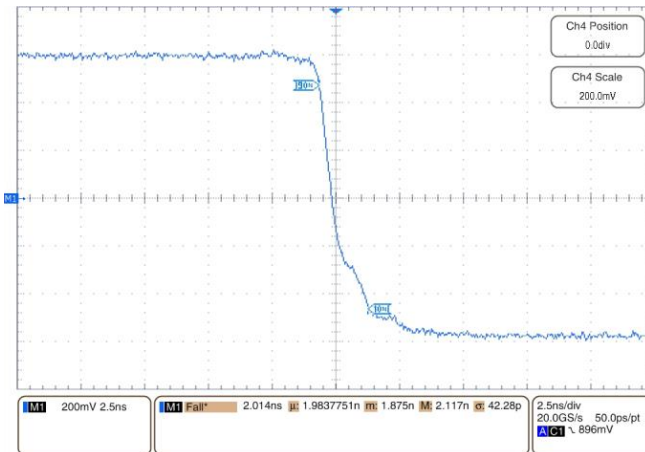

$V_{CC} = 3.3\text{ V}$        $T_A = 25^\circ\text{C}$

图 20. Driver Fall Time

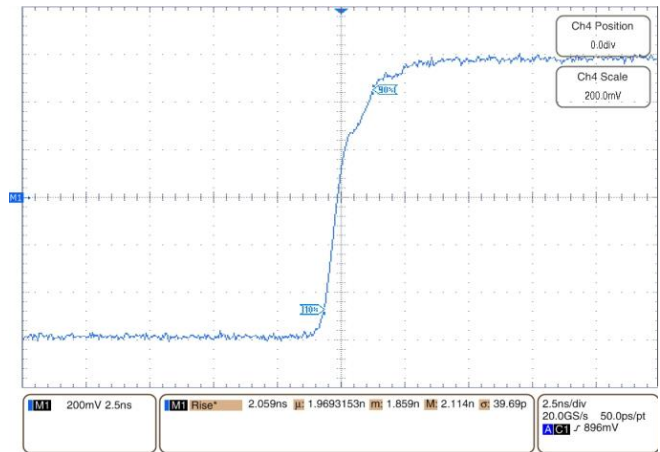

$V_{CC} = 3.3\text{ V}$        $T_A = 25^\circ\text{C}$

图 21. Driver Rise Time

## 10 Power Supply Recommendations

The M-LVDS driver and receivers in this data sheet are designed to operate from a single power supply. Both drivers and receivers operate with supply voltages in the range of 3 V to 3.6 V. In a typical application, a driver and a receiver may be on separate boards, or even separate equipment. In these cases, separate supplies would be used at each location. The expected ground potential difference between the driver power supply and the receiver power supply would be less than  $\pm 1$  V. Board level and local device level bypass capacitance should be used and are covered Supply Bypass Capacitance.

## 11 Layout

### 11.1 Layout Guidelines

#### 11.1.1 Microstrip vs. Stripline Topologies

As per SLLD009, printed-circuit boards usually offer designers two transmission line options: Microstrip and stripline. Microstrips are traces on the outer layer of a PCB, as shown in 图 22.



图 22. Microstrip Topology

On the other hand, striplines are traces between two ground planes. Striplines are less prone to emissions and susceptibility problems because the reference planes effectively shield the embedded traces. However, from the standpoint of high-speed transmission, juxtaposing two planes creates additional capacitance. TI recommends routing M-LVDS signals on microstrip transmission lines if possible. The PCB traces allow designers to specify the necessary tolerances for  $Z_0$  based on the overall noise budget and reflection allowances. Footnotes 1<sup>(1)</sup>, 2<sup>(2)</sup>, and 3<sup>(3)</sup> provide formulas for  $Z_0$  and  $t_{PD}$  for differential and single-ended traces. <sup>(1)</sup> <sup>(2)</sup> <sup>(3)</sup>

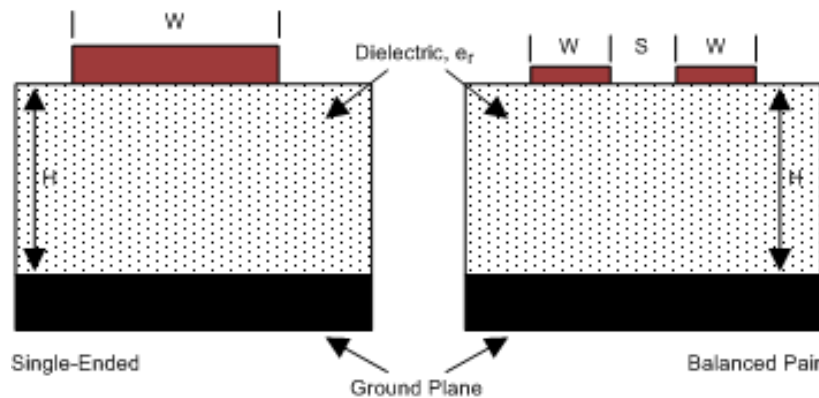

图 23. Stripline Topology

(1) Howard Johnson & Martin Graham. 1993. High Speed Digital Design – A Handbook of Black Magic. Prentice Hall PRT. ISBN number 013395724.

(2) Mark I. Montrose. 1996. Printed Circuit Board Design Techniques for EMC Compliance. IEEE Press. ISBN number 0780311310.

(3) Clyde F. Coombs, Jr. Ed, Printed Circuits Handbook, McGraw Hill, ISBN number 0070127549.

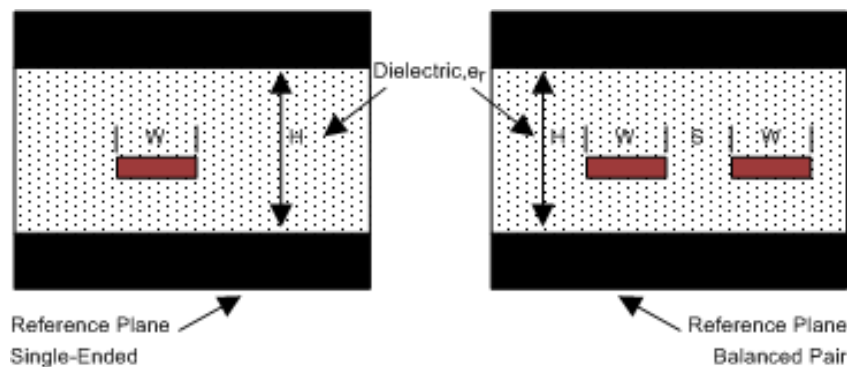

## Layout Guidelines (接下页)

### 11.1.2 Dielectric Type and Board Construction

The speeds at which signals travel across the board dictates the choice of dielectric. FR-4, or equivalent, usually provides adequate performance for use with M-LVDS signals. If rise or fall times of TTL/CMOS signals are less than 500 ps, empirical results indicate that a material with a dielectric constant near 3.4, such as Rogers™ 4350 or Nelco N4000-13 is better suited. Once the designer chooses the dielectric, there are several parameters pertaining to the board construction that can affect performance. The following set of guidelines were developed experimentally through several designs involving M-LVDS devices:

- Copper weight: 15 g or 1/2 oz start, plated to 30 g or 1 oz
- All exposed circuitry should be solder-plated (60/40) to 7.62 μm or 0.0003 in (minimum).
- Copper plating should be 25.4 μm or 0.001 in (minimum) in plated-through-holes.
- Solder mask over bare copper with solder hot-air leveling

### 11.1.3 Recommended Stack Layout

Following the choice of dielectrics and design specifications, you must decide how many levels to use in the stack. To reduce the TTL/CMOS to M-LVDS crosstalk, it is a good practice to have at least two separate signal planes as shown in 图 24.



图 24. Four-Layer PCB Board

#### 注

The separation between layers 2 and 3 should be 127 μm (0.005 in). By keeping the power and ground planes tightly coupled, the increased capacitance acts as a bypass for transients.

One of the most common stack configurations is the six-layer board, as shown in 图 25.

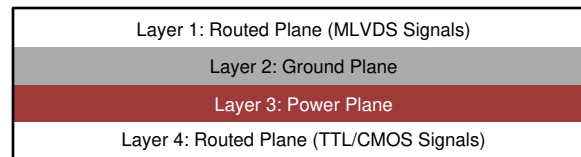

图 25. Six-Layer PCB Board

In this particular configuration, it is possible to isolate each signal layer from the power plane by at least one ground plane. The result is improved signal integrity; however, fabrication is more expensive. Using the 6-layer board is preferable, because it offers the layout designer more flexibility in varying the distance between signal layers and referenced planes, in addition to ensuring reference to a ground plane for signal layers 1 and 6.

## Layout Guidelines (接下页)

### 11.1.4 Separation Between Traces

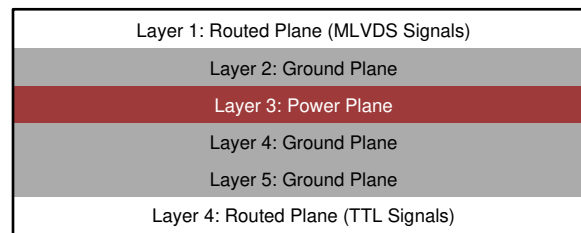
The separation between traces depends on several factors; however, the amount of coupling that can be tolerated usually dictates the actual separation. Low noise coupling requires close coupling between the differential pair of an M-LVDS link to benefit from the electromagnetic field cancellation. The traces should be 100-Ω differential and thus coupled in the manner that best fits this requirement. In addition, differential pairs should have the same electrical length to ensure that they are balanced, thus minimizing problems with skew and signal reflection.

In the case of two adjacent single-ended traces, one should use the 3-W rule, which stipulates that the distance between two traces must be greater than two times the width of a single trace, or three times its width measured from trace center to trace center. This increased separation effectively reduces the potential for crosstalk. The same rule should be applied to the separation between adjacent M-LVDS differential pairs, whether the traces are edge-coupled or broad-side-coupled.

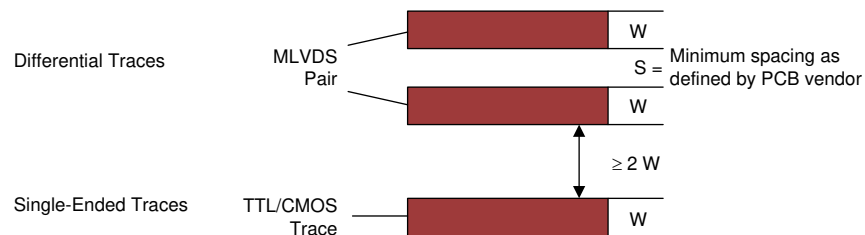

**图 26. 3-W Rule for Single-Ended and Differential Traces (Top View)**

You should exercise caution when using autorouters, because they do not always account for all factors affecting crosstalk and signal reflection. For instance, it is best to avoid sharp 90° turns to prevent discontinuities in the signal path. Using successive 45° turns tends to minimize reflections.

### 11.1.5 Crosstalk and Ground Bounce Minimization

To reduce crosstalk, it is important to provide a return path to high-frequency currents that is as close as possible to its originating trace. A ground plane usually achieves this. Because the returning currents always choose the path of lowest inductance, they are most likely to return directly under the original trace, thus minimizing crosstalk. Lowering the area of the current loop lowers the potential for crosstalk. Traces kept as short as possible with an uninterrupted ground plane running beneath them emit the minimum amount of electromagnetic field strength. Discontinuities in the ground plane increase the return path inductance and should be avoided.

### 11.1.6 Decoupling

Each power or ground lead of a high-speed device should be connected to the PCB through a low inductance path. For best results, one or more vias are used to connect a power or ground pin to the nearby plane. Ideally, via placement is immediately adjacent to the pin to avoid adding trace inductance. Placing a power plane closer to the top of the board reduces the effective via length and its associated inductance.

Layout Guidelines (接下页)



图 27. Low Inductance, High-Capacitance Power Connection

Bypass capacitors should be placed close to V<sub>DD</sub> pins. They can be placed conveniently near the corners or underneath the package to minimize the loop area. This extends the useful frequency range of the added capacitance. Small-physical-size capacitors, such as 0402, 0201, or X7R surface-mount capacitors should be used to minimize body inductance of capacitors. Each bypass capacitor is connected to the power and ground plane through vias tangent to the pads of the capacitor as shown in 图 28(a).

An X7R surface-mount capacitor of size 0402 has about 0.5 nH of body inductance. At frequencies above 30 MHz or so, X7R capacitors behave as low-impedance inductors. To extend the operating frequency range to a few hundred MHz, an array of different capacitor values like 100 pF, 1 nF, 0.03 μF, and 0.1 μF are commonly used in parallel. The most effective bypass capacitor can be built using sandwiched layers of power and ground at a separation of 2 to 3 mils. With a 2-mil FR4 dielectric, there is approximately 500 pF per square inch of PCB. Many high-speed devices provide a low-inductance GND connection on the backside of the package. This center pad must be connected to a ground plane through an array of vias. The via array reduces the effective inductance to ground and enhances the thermal performance of the small Surface Mount Technology (SMT) package. Placing vias around the perimeter of the pad connection ensures proper heat spreading and the lowest possible die temperature. Placing high-performance devices on opposing sides of the PCB using two GND planes (as shown in 图 19) creates multiple paths for heat transfer. Often thermal PCB issues are the result of one device adding heat to another, resulting in a very high local temperature. Multiple paths for heat transfer minimize this possibility. In many cases the GND pad makes the optimal decoupling layout impossible to achieve due to insufficient pad-to-pad spacing as shown in 图 28(b). When this occurs, placing the decoupling capacitor on the backside of the board keeps the extra inductance to a minimum. It is important to place the V<sub>DD</sub> via as close to the device pin as possible while still allowing for sufficient solder mask coverage. If the via is left open, solder may flow from the pad and into the via barrel. This will result in a poor solder connection.

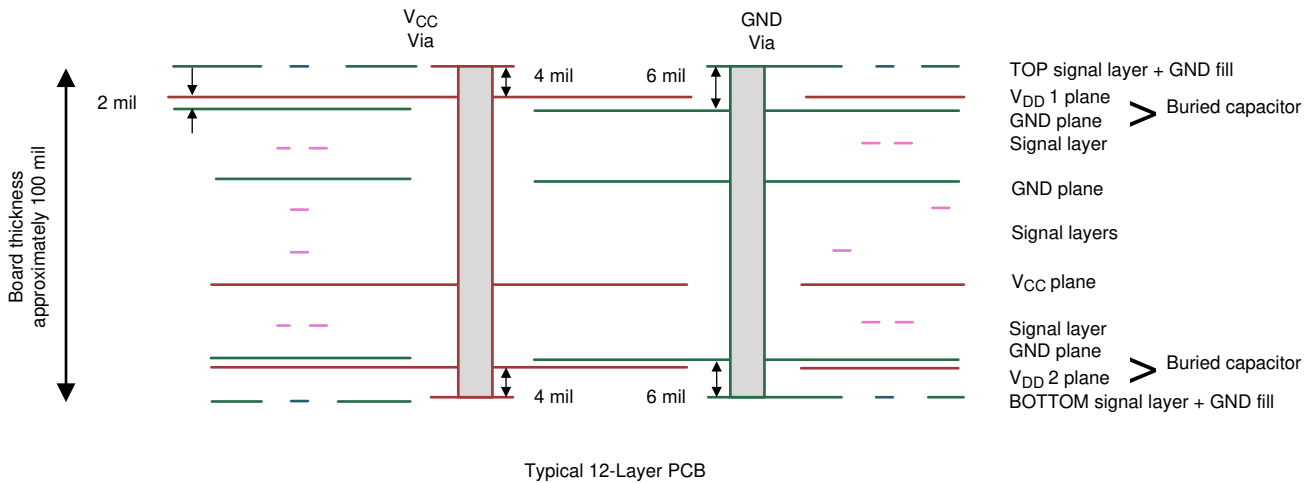

图 28. Typical Decoupling Capacitor Layouts

## 11.2 Layout Example

At least two or three times the width of an individual trace should separate single-ended traces and differential pairs to minimize the potential for crosstalk. Single-ended traces that run in parallel for less than the wavelength of the rise or fall times usually have negligible crosstalk. Increase the spacing between signal paths for long parallel runs to reduce crosstalk. Boards with limited real estate can benefit from the staggered trace layout, as shown in [图 29](#).

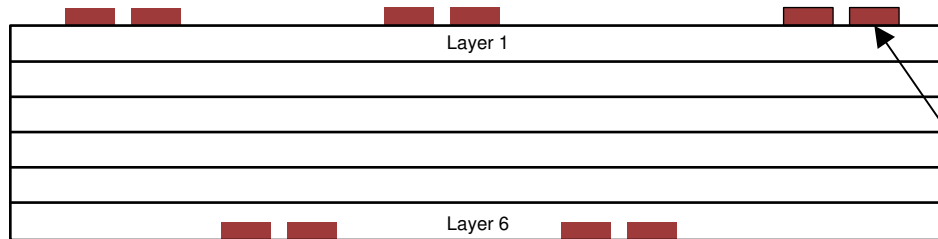

**图 29. Staggered Trace Layout**

## Layout Example (接下页)

This configuration lays out alternating signal traces on different layers; thus, the horizontal separation between traces can be less than 2 or 3 times the width of individual traces. To ensure continuity in the ground signal path, TI recommends having an adjacent ground via for every signal via, as shown in [图 30](#). Note that vias create additional capacitance. For example, a typical via has a lumped capacitance effect of 1/2 pF to 1 pF in FR4.

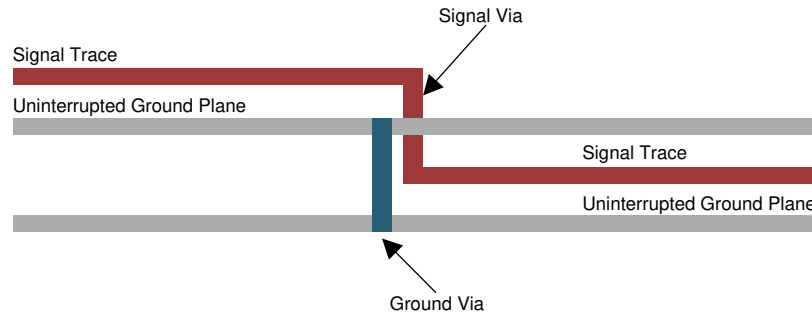

**图 30. Ground Via Location (Side View)**

Short and low-impedance connection of the device ground pins to the PCB ground plane reduces ground bounce. Holes and cutouts in the ground planes can adversely affect current return paths if they create discontinuities that increase returning current loop areas.

To minimize EMI problems, TI recommends avoiding discontinuities below a trace (for example, holes, slits, and so on) and keeping traces as short as possible. Zoning the board wisely by placing all similar functions in the same area, as opposed to mixing them together, helps reduce susceptibility issues.

## 12 器件和文档支持

### 12.1 文档支持

### 12.2 接收文档更新通知

要接收文档更新通知，请导航至 [ti.com.cn](http://ti.com.cn) 上的器件产品文件夹。单击右上角的通知我进行注册，即可每周接收产品信息更改摘要。有关更改的详细信息，请查看任何已修订文档中包含的修订历史记录。

### 12.3 支持资源

[TI E2E™ support forums](#) are an engineer's go-to source for fast, verified answers and design help — straight from the experts. Search existing answers or ask your own question to get the quick design help you need.

Linked content is provided "AS IS" by the respective contributors. They do not constitute TI specifications and do not necessarily reflect TI's views; see TI's [Terms of Use](#).

### 12.4 商标

E2E is a trademark of Texas Instruments.

Rogers is a trademark of Rogers Corporation.

All other trademarks are the property of their respective owners.

### 12.5 静电放电警告



ESD 可能会损坏该集成电路。德州仪器 (TI) 建议通过适当的预防措施处理所有集成电路。如果不遵守正确的处理措施和安装程序，可能会损坏集成电路。

ESD 的损坏小至导致微小的性能降级，大至整个器件故障。精密的集成电路可能更容易受到损坏，这是因为非常细微的参数更改都可能会导致器件与其发布的规格不相符。

### 12.6 Glossary

[SLYZ022](#) — *TI Glossary*.

This glossary lists and explains terms, acronyms, and definitions.

## 13 机械、封装和可订购信息

以下页面包含机械、封装和可订购信息。这些信息是指定器件的最新可用数据。数据如有变更，恕不另行通知，且不会对此文档进行修订。如需获取此数据表的浏览器版本，请查阅左侧的导航栏。

**PACKAGING INFORMATION**

Orderable Device	Status (1)	Package Type	Package Drawing	Pins	Package Qty	Eco Plan (2)	Lead finish/ Ball material (6)	MSL Peak Temp (3)	Op Temp (°C)	Device Marking (4/5)	Samples
SN65MLVD206BD	ACTIVE	SOIC	D	8	75	RoHS & Green	NIPDAU	Level-1-260C-UNLIM	-40 to 85	MF206B	<a href="#">Samples</a>
SN65MLVD206BDR	ACTIVE	SOIC	D	8	2500	RoHS & Green	NIPDAU	Level-1-260C-UNLIM	-40 to 85	MF206B	<a href="#">Samples</a>

(1) The marketing status values are defined as follows:

**ACTIVE:** Product device recommended for new designs.

**LIFEBUY:** TI has announced that the device will be discontinued, and a lifetime-buy period is in effect.

**NRND:** Not recommended for new designs. Device is in production to support existing customers, but TI does not recommend using this part in a new design.

**PREVIEW:** Device has been announced but is not in production. Samples may or may not be available.

**OBSOLETE:** TI has discontinued the production of the device.

(2) **RoHS:** TI defines "RoHS" to mean semiconductor products that are compliant with the current EU RoHS requirements for all 10 RoHS substances, including the requirement that RoHS substance do not exceed 0.1% by weight in homogeneous materials. Where designed to be soldered at high temperatures, "RoHS" products are suitable for use in specified lead-free processes. TI may reference these types of products as "Pb-Free".

**RoHS Exempt:** TI defines "RoHS Exempt" to mean products that contain lead but are compliant with EU RoHS pursuant to a specific EU RoHS exemption.

**Green:** TI defines "Green" to mean the content of Chlorine (Cl) and Bromine (Br) based flame retardants meet JS709B low halogen requirements of <=1000ppm threshold. Antimony trioxide based flame retardants must also meet the <=1000ppm threshold requirement.

(3) MSL, Peak Temp. - The Moisture Sensitivity Level rating according to the JEDEC industry standard classifications, and peak solder temperature.

(4) There may be additional marking, which relates to the logo, the lot trace code information, or the environmental category on the device.

(5) Multiple Device Markings will be inside parentheses. Only one Device Marking contained in parentheses and separated by a "~" will appear on a device. If a line is indented then it is a continuation of the previous line and the two combined represent the entire Device Marking for that device.

(6) Lead finish/Ball material - Orderable Devices may have multiple material finish options. Finish options are separated by a vertical ruled line. Lead finish/Ball material values may wrap to two lines if the finish value exceeds the maximum column width.

**Important Information and Disclaimer:**The information provided on this page represents TI's knowledge and belief as of the date that it is provided. TI bases its knowledge and belief on information provided by third parties, and makes no representation or warranty as to the accuracy of such information. Efforts are underway to better integrate information from third parties. TI has taken and continues to take reasonable steps to provide representative and accurate information but may not have conducted destructive testing or chemical analysis on incoming materials and chemicals. TI and TI suppliers consider certain information to be proprietary, and thus CAS numbers and other limited information may not be available for release.

In no event shall TI's liability arising out of such information exceed the total purchase price of the TI part(s) at issue in this document sold by TI to Customer on an annual basis.





**TAPE AND REEL INFORMATION**

**QUADRANT ASSIGNMENTS FOR PIN 1 ORIENTATION IN TAPE**

\*All dimensions are nominal

Device	Package Type	Package Drawing	Pins	SPQ	Reel Diameter (mm)	Reel Width W1 (mm)	A0 (mm)	B0 (mm)	K0 (mm)	P1 (mm)	W (mm)	Pin1 Quadrant
SN65MLVD206BDR	SOIC	D	8	2500	330.0	12.4	6.4	5.2	2.1	8.0	12.0	Q1

**TAPE AND REEL BOX DIMENSIONS**

\*All dimensions are nominal

Device	Package Type	Package Drawing	Pins	SPQ	Length (mm)	Width (mm)	Height (mm)
SN65MLVD206BDR	SOIC	D	8	2500	353.0	353.0	32.0

**TUBE**

\*All dimensions are nominal

Device	Package Name	Package Type	Pins	SPQ	L (mm)	W (mm)	T (μm)	B (mm)
SN65MLVD206BD	D	SOIC	8	75	507	8	3940	4.32



**D0008A**

**PACKAGE OUTLINE**

**SOIC - 1.75 mm max height**

SMALL OUTLINE INTEGRATED CIRCUIT



4214825/C 02/2019

**NOTES:**

1. Linear dimensions are in inches [millimeters]. Dimensions in parenthesis are for reference only. Controlling dimensions are in inches. Dimensioning and tolerancing per ASME Y14.5M.
2. This drawing is subject to change without notice.
3. This dimension does not include mold flash, protrusions, or gate burrs. Mold flash, protrusions, or gate burrs shall not exceed  $.006$  [0.15] per side.
4. This dimension does not include interlead flash.
5. Reference JEDEC registration MS-012, variation AA.

# EXAMPLE BOARD LAYOUT

D0008A

SOIC - 1.75 mm max height

SMALL OUTLINE INTEGRATED CIRCUIT



LAND PATTERN EXAMPLE  
EXPOSED METAL SHOWN  
SCALE:8X



SOLDER MASK DETAILS

4214825/C 02/2019

NOTES: (continued)

- 6. Publication IPC-7351 may have alternate designs.
- 7. Solder mask tolerances between and around signal pads can vary based on board fabrication site.

# EXAMPLE STENCIL DESIGN

D0008A

SOIC - 1.75 mm max height

SMALL OUTLINE INTEGRATED CIRCUIT



SOLDER PASTE EXAMPLE  
BASED ON .005 INCH [0.125 MM] THICK STENCIL  
SCALE:8X

4214825/C 02/2019

NOTES: (continued)

8. Laser cutting apertures with trapezoidal walls and rounded corners may offer better paste release. IPC-7525 may have alternate design recommendations.
9. Board assembly site may have different recommendations for stencil design.

## 重要声明和免责声明

TI“按原样”提供技术和可靠性数据（包括数据表）、设计资源（包括参考设计）、应用或其他设计建议、网络工具、安全信息和其他资源，不保证没有瑕疵且不做任何明示或暗示的担保，包括但不限于对适销性、某特定用途方面的适用性或不侵犯任何第三方知识产权的暗示担保。

这些资源可供使用 TI 产品进行设计的熟练开发人员使用。您将自行承担以下全部责任：(1) 针对您的应用选择合适的 TI 产品，(2) 设计、验证并测试您的应用，(3) 确保您的应用满足相应标准以及任何其他功能安全、信息安全、监管或其他要求。

这些资源如有变更，恕不另行通知。TI 授权您仅可将这些资源用于研发本资源所述的 TI 产品的应用。严禁对这些资源进行其他复制或展示。您无权使用任何其他 TI 知识产权或任何第三方知识产权。您应全额赔偿因在这些资源的使用中对 TI 及其代表造成的任何索赔、损害、成本、损失和债务，TI 对此概不负责。

TI 提供的产品受 [TI 的销售条款](#) 或 [ti.com](#) 上其他适用条款/TI 产品随附的其他适用条款的约束。TI 提供这些资源并不会扩展或以其他方式更改 TI 针对 TI 产品发布的适用的担保或担保免责声明。

TI 反对并拒绝您可能提出的任何其他或不同的条款。

邮寄地址：Texas Instruments, Post Office Box 655303, Dallas, Texas 75265

Copyright © 2024，德州仪器 (TI) 公司