

SN74AHC132 具有施密特触发输入的八路正与非门

1 特性

- 工作范围为 2V 至 5.5V V_{CC}
- 采用极低输入转换工作
- 温度补偿阈值电平
- 高抗噪性
- 与 SNx4AHC00 的引脚排列相同
- 闩锁性能超过 250mA，符合 JESD 17 规范
- ESD 保护性能超过 JESD 22 规范要求
 - 2000V 人体放电模型
 - 1000V 充电器件模型

2 应用

- 电子销售终端
- 电信基础设施
- 网络交换机
- 测试和测量

3 说明

SN74AHC132 器件是一款八路正与非门，可在 2V 至 5.5V V_{CC} 下运行。该器件以正逻辑执行布尔函数 $Y = A \times B$ 或 $Y = \overline{A + B}$ 。

施密特触发输入可提供更高的抗噪性，并支持慢速输入信号转换。

封装信息

器件型号	封装 ⁽¹⁾	封装尺寸 ⁽²⁾	封装尺寸 ⁽³⁾
SN74AHC132	BQA (WQFN , 14)	3mm × 2.5mm	3mm × 2.5mm
	D (SOIC , 14)	8.65mm × 6mm	8.65mm × 3.9mm
	DB (SSOP , 14)	6.2mm × 7.8mm	6.2mm × 5.3mm
	DGV (TVSOP , 14)	3.6mm × 6.4mm	3.6mm × 4.4mm
	PW (TSSOP , 14)	5mm × 6.4mm	5mm × 4.4mm
	RGY (VQFN , 14)	3.5mm × 3.5mm	3.5mm × 3.5mm
	N (PDIP , 14)	19.3mm × 9.4mm	19.3mm × 6.35mm
NS (SOP , 14)	10.2mm × 7.8mm	5.3mm × 10.3mm	

(1) 更多相关信息，请参阅第 11 节。

(2) 封装尺寸 (长 × 宽) 为标称值，并包括引脚 (如适用)

(3) 封装尺寸 (长 × 宽) 为标称值，不包括引脚。

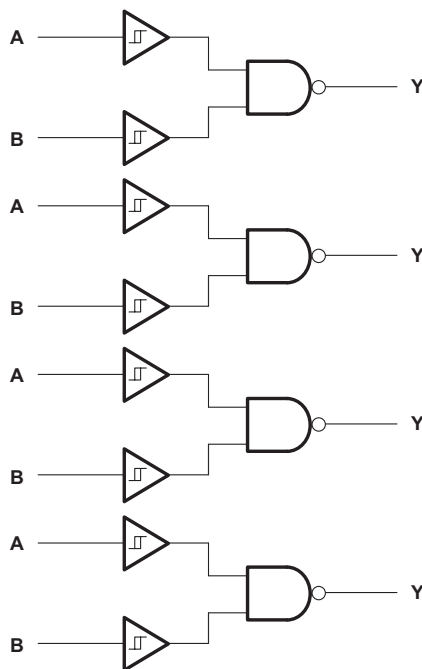

简化版原理图



Table of Contents

1 特性	1	7.2 Functional Block Diagram.....	9
2 应用	1	7.3 Feature Description.....	9
3 说明	1	7.4 Device Functional Modes.....	9
4 Pin Configuration and Functions	3	8 Application and Implementation	10
5 Specifications	4	8.1 Application Information.....	10
5.1 Absolute Maximum Ratings.....	4	8.2 Typical Application.....	10
5.2 Handling Ratings.....	4	8.3 Power Supply Recommendations.....	11
5.3 Recommended Operating Conditions.....	4	8.4 Layout.....	11
5.4 Thermal Information.....	5	9 Device and Documentation Support	12
5.5 Electrical Characteristics.....	5	9.1 Documentation Support (Analog).....	12
5.6 Switching Characteristics, $V_{CC} = 3.3 V \pm 0.3 V$	6	9.2 接收文档更新通知.....	12
5.7 Switching Characteristics, $V_{CC} = 5 V \pm 0.5 V$	6	9.3 支持资源.....	12
5.8 Noise Characteristics.....	6	9.4 Trademarks.....	12
5.9 Operating Characteristics.....	6	9.5 静电放电警告.....	12
5.10 Typical Characteristics.....	7	9.6 术语表.....	12
6 Parameter Measurement Information	8	10 Revision History	12
7 Detailed Description	9	11 Mechanical, Packaging, and Orderable Information	13
7.1 Overview.....	9		

4 Pin Configuration and Functions



图 4-1. SN74AHC132 D, DB, DGV, N, NS, or PW Package, 14-Pin (Top View)



图 4-2. SN74AHC132 RGY Package, 14-Pin VQFN (Top View)

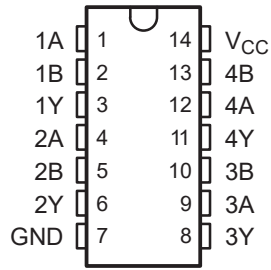

图 4-3. SN74AHC132 BQA Package, 14-Pin WQFN (Top View)

表 4-1. Pin Functions

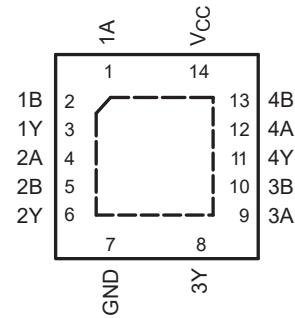
PIN		TYPE ⁽¹⁾	DESCRIPTION
NAME	NO.		
1A	1	I	1A Input
1B	2	I	1B Input
1Y	3	O	1Y Output
2A	4	I	2A Input
2B	5	I	2B Input
2Y	6	O	2Y Output
3Y	8	O	3Y Output
3A	9	I	3A Input
3B	10	I	3B Input
4Y	11	O	4Y Output
4A	12	I	4A Input
4B	13	I	4B Input
GND	7	—	Ground Pin
V _{CC}	14	—	Power Pin
Thermal Pad ⁽²⁾		—	The thermal pad can be connected to GND or left floating. Do not connect to any other signal or supply.

(1) I = input, O = output

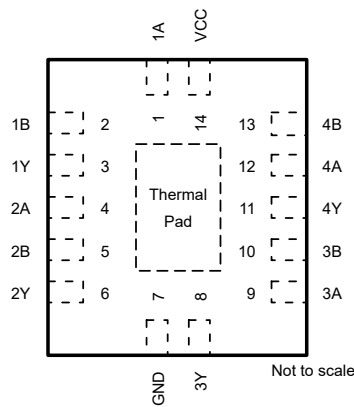
(2) For BQA only.

5 Specifications

5.1 Absolute Maximum Ratings

over operating free-air temperature range (unless otherwise noted) ⁽¹⁾

		MIN	MAX	UNIT
V _{CC}	Supply voltage range	- 0.5	7	V
V _I	Input voltage range ⁽²⁾	- 0.5	7	V
V _O	Output voltage range ⁽²⁾	- 0.5	V _{CC} + 0.5	V
I _{IK}	Input clamp current	V _I < 0	- 20	mA
I _{OK}	Output clamp current	V _O < 0 or V _O > V _{CC}	±20	mA
I _O	Continuous output current	V _O = 0 to V _{CC}	±25	mA
Continuous current through V _{CC} or GND			±50	mA

- (1) Stresses beyond those listed under *Absolute Maximum Ratings* may cause permanent damage to the device. These are stress ratings only, and functional operation of the device at these or any other conditions beyond those indicated under *Recommended Operating Conditions* is not implied. Exposure to absolute-maximum-rated conditions for extended periods may affect device reliability.
- (2) The input and output voltage ratings may be exceeded if the input and output current ratings are observed.

5.2 Handling Ratings

		MIN	MAX	UNIT	
T _{stg}	Storage temperature range	- 65	150	°C	
V _(ESD)	Electrostatic discharge	Human body model (HBM), per ANSI/ESDA/JEDEC JS-001, all pins ⁽¹⁾	0	2000	V
		Charged device model (CDM), per JEDEC specification JESD22-C101, all pins ⁽²⁾	0	1000	

- (1) JEDEC document JEP155 states that 500-V HBM allows safe manufacturing with a standard ESD control process.
- (2) JEDEC document JEP157 states that 250-V CDM allows safe manufacturing with a standard ESD control process.

5.3 Recommended Operating Conditions

over operating free-air temperature range (unless otherwise noted)⁽¹⁾

		SN74AHC132		UNIT
		MIN	MAX	
V _{CC}	Supply voltage	2	5.5	V
V _I	Input voltage	0	5.5	V
V _O	Output voltage	0	V _{CC}	V
I _{OH}	High-level output current	V _{CC} = 2 V	- 50	μA
		V _{CC} = 3.3 V ± 0.3 V	- 4	mA
		V _{CC} = 5 V ± 0.5 V	- 8	
I _{OL}	Low-level output current	V _{CC} = 2 V	50	μA
		V _{CC} = 3.3 V ± 0.3 V	4	mA
		V _{CC} = 5 V ± 0.5 V	8	
T _A	Operating free-air temperature	- 40	125	°C

- (1) All unused inputs of the device must be held at V_{CC} or GND for proper device operation. Refer to the TI application report, *Implications of Slow or Floating CMOS Inputs* (SCBA004).

5.4 Thermal Information

THERMAL METRIC ⁽¹⁾	SN74AHC132									UNIT
	BQA	D	DB	DR	N	NS	PW	RGY		
	14 PINS									
$R_{\theta JA}$ Junction-to-ambient thermal resistance	88.3	124.6	107.1	90.6	57.4	90.7	147.7	57.5	°C/W	
$R_{\theta JC(top)}$ Junction-to-case (top) thermal resistance	90.9	79.7	59.6	50.9	44.9	48.3	77.4	57.5		
$R_{\theta JB}$ Junction-to-board thermal resistance	56.8	81.2	54.4	44.8	37.2	49.4	90.9	33.6		
ψ_{JT} Junction-to-top characterization parameter	9.9	39.3	20.5	14.7	30.1	14.6	27.2	3.4		
ψ_{JB} Junction-to-board characterization parameter	56.7	80.8	53.8	44.5	37.1	49.1	90.2	33.7		
$R_{\theta JC(bot)}$ Junction-to-case (bottom) thermal resistance	33.4	N/A	N/A	N/A	N/A	N/A	N/A	13.9		

(1) For more information about traditional and new thermal metrics, see the *IC Package Thermal Metrics* application report (SPRA953).

5.5 Electrical Characteristics

over recommended operating free-air temperature range (unless otherwise noted)

PARAMETER	TEST CONDITIONS	V_{CC}	$T_A = 25^\circ\text{C}$			SN74AHC132		-40°C to 125°C SN74AHC132		UNIT
			MIN	TYP	MAX	MIN	MAX	MIN	MAX	
V_{T+} Positive-going input threshold voltage		3 V	1.2		2.2	1.2	2.2	1.2	2.2	V
		4.5 V	1.75		3.15	1.75	3.15	1.75	3.15	
		5.5 V	2.15		3.85	2.15	3.85	2.15	3.85	
V_{T-} Negative-going input threshold voltage		3 V	0.9		1.9	0.9	1.9	0.9	1.9	V
		4.5 V	1.35		2.75	1.35	2.75	1.35	2.75	
		5.5 V	1.65		3.35	1.65	3.35	1.65	3.35	
ΔV_T Hysteresis ($V_{T+} - V_{T-}$)		3 V	0.3		1.2	0.3	1.2	0.3	1.2	V
		4.5 V	0.4		1.4	0.4	1.4	0.4	1.4	
		5.5 V	0.5		1.6	0.5	1.6	0.5	1.6	
V_{OH}	$I_{OH} = -50 \mu\text{A}$	2 V	1.9	2		1.9		1.9		V
		3 V	2.9	3		2.9		2.9		
		4.5 V	4.4	4.5		4.4		4.4		
	$I_{OH} = -4 \text{ mA}$	3 V	2.58			2.48		2.48		
	$I_{OH} = -8 \text{ mA}$	4.5 V	3.94			3.8		3.8		
V_{OL}	$I_{OL} = 50 \mu\text{A}$	2 V			0.1		0.1		0.1	V
		3 V			0.1		0.1		0.1	
		4.5 V			0.1		0.1		0.1	
	$I_{OL} = 4 \text{ mA}$	3 V			0.36		0.44		0.44	
	$I_{OL} = 8 \text{ mA}$	4.5 V			0.36		0.44		0.44	
I_I	$V_I = 5.5 \text{ V or GND}$	0 V to 5.5 V			± 0.1		± 1		± 1	μA
I_{CC}	$V_I = V_{CC} \text{ or GND}$ $I_O = 0$	5.5 V			2		20		20	μA
C_i	$V_I = V_{CC} \text{ or GND}$	5 V		1.9	10		10		10	pF

5.6 Switching Characteristics, $V_{CC} = 3.3\text{ V} \pm 0.3\text{ V}$

over recommended operating free-air temperature range (unless otherwise noted) (see (1))

PARAMETER	FROM (INPUT)	TO (OUTPUT)	LOAD CAPACITANCE	$T_A = 25^\circ\text{C}$			SN74AHC132		$T_A = -40^\circ\text{C to } 125^\circ\text{C}$ SN74AHC132		UNIT
				MIN	TYP	MAX	MIN	MAX	MIN	MAX	
t_{PLH}	A or B	Y	$C_L = 15\text{ pF}$		5.6 ⁽¹⁾	11.9 ⁽¹⁾	1	14	1	15	ns
t_{PHL}					5.6 ⁽¹⁾	11.9 ⁽¹⁾	1	14	1	15	
t_{PLH}	A or B	Y	$C_L = 50\text{ pF}$		7.6	15.4	1	17.5	1	19	ns
t_{PHL}					7.6	15.4	1	17.5	1	19	

(1) On products compliant to MIL-PRF-38535, this parameter is not production tested.

5.7 Switching Characteristics, $V_{CC} = 5\text{ V} \pm 0.5\text{ V}$

over recommended operating free-air temperature range (unless otherwise noted) (see (1))

PARAMETER	FROM (INPUT)	TO (OUTPUT)	LOAD CAPACITANCE	$T_A = 25^\circ\text{C}$			SN74AHC132		$T_A = -40^\circ\text{C to } 125^\circ\text{C}$ SN74AHC132		UNIT
				MIN	TYP	MAX	MIN	MAX	MIN	MAX	
t_{PLH}	A or B	Y	$C_L = 15\text{ pF}$		3.9 ⁽¹⁾	7.7 ⁽¹⁾	1	9	1	10	ns
t_{PHL}					3.9 ⁽¹⁾	7.7 ⁽¹⁾	1	9	1	10	
t_{PLH}	A or B	Y	$C_L = 50\text{ pF}$		5.3	9.7	1	11	1	12	ns
t_{PHL}					5.3	9.7	1	11	1	12	

(1) On products compliant to MIL-PRF-38535, this parameter is not production tested.

5.8 Noise Characteristics

$V_{CC} = 5\text{ V}$, $C_L = 50\text{ pF}$, $T_A = 25^\circ\text{C}$ ⁽¹⁾

PARAMETER		SN74AHC132			UNIT
		MIN	TYP	MAX	
$V_{OL(P)}$	Quiet output, maximum dynamic V_{OL}		0.45	0.8	V
$V_{OL(V)}$	Quiet output, minimum dynamic V_{OL}		-0.35	-0.8	V
$V_{OH(V)}$	Quiet output, minimum dynamic V_{OH}		4.8		V
$V_{IH(D)}$	High-level dynamic input voltage		3.5		V
$V_{IL(D)}$	Low-level dynamic input voltage			1.5	V

(1) Characteristics are for surface-mount packages only.

5.9 Operating Characteristics

$V_{CC} = 5\text{ V}$, $T_A = 25^\circ\text{C}$

PARAMETER	TEST CONDITIONS	TYP	UNIT
C_{pd}	Power dissipation capacitance No load, $f = 1\text{ MHz}$	11	pF

5.10 Typical Characteristics

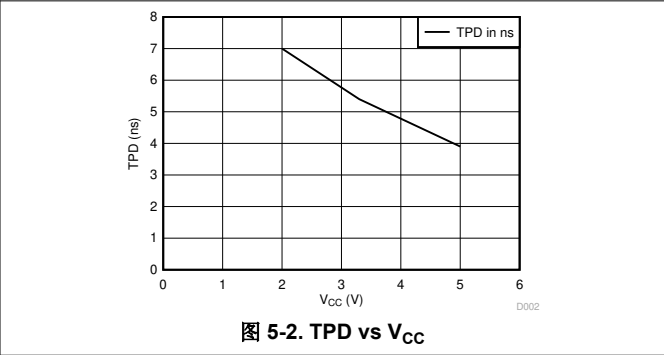
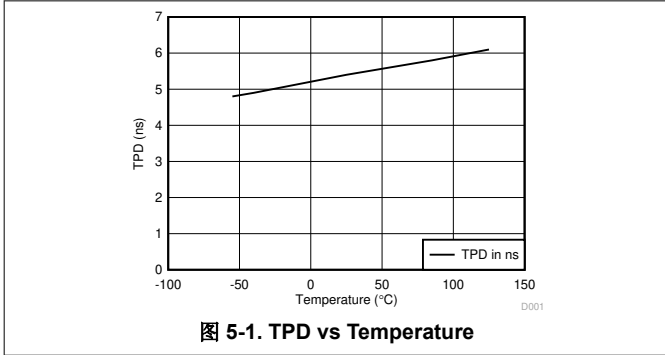

6 Parameter Measurement Information

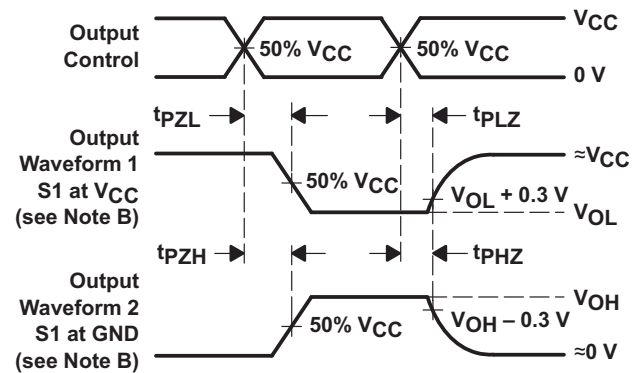
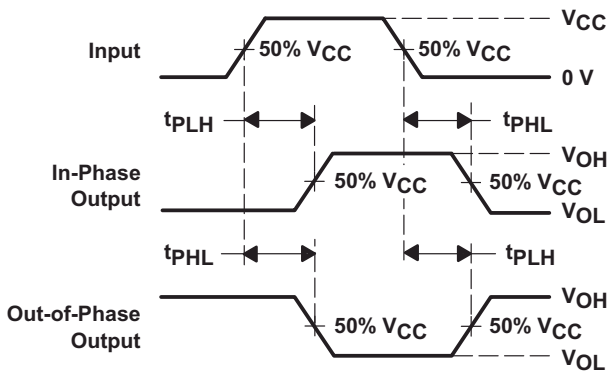
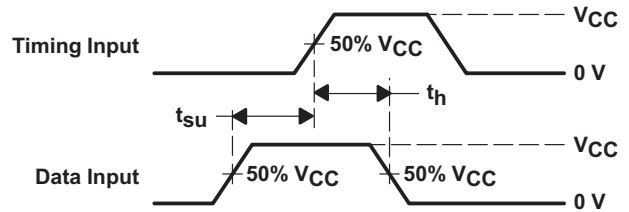
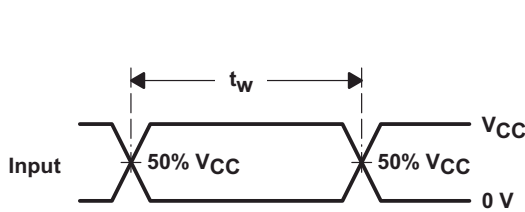
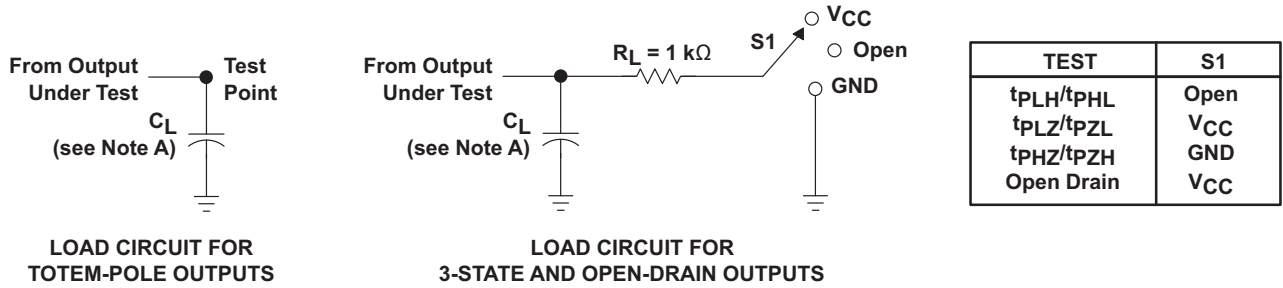

- NOTES: A. C_L includes probe and jig capacitance.
 B. Waveform 1 is for an output with internal conditions such that the output is low except when disabled by the output control. Waveform 2 is for an output with internal conditions such that the output is high except when disabled by the output control.
 C. All input pulses are supplied by generators having the following characteristics: $PRR \leq 1$ MHz, $Z_O = 50 \Omega$, $t_r \leq 3$ ns, $t_f \leq 3$ ns.
 D. The outputs are measured one at a time with one input transition per measurement.
 E. All parameters and waveforms are not applicable to all devices.

图 6-1. Load Circuit and Voltage Waveforms

7 Detailed Description

7.1 Overview

The SN74AHC132 is a quadruple 2-input positive-NAND gate with low drive that produces slow rise and fall times. This reduces ringing on the output signal.

Each circuit functions as a NAND gate, but because of the Schmitt action, it has different input threshold levels for positive- and negative-going signals.

These circuits are temperature compensated and can be triggered from the slowest of input ramps and still give clean, jitter-free output signals.

7.2 Functional Block Diagram



图 7-1. Logic Diagram, Each Gate (Positive Logic)

7.3 Feature Description

- Wide operating voltage range
 - Operates from 2 V to 5.5 V
- Allows down voltage translation
 - Inputs accept voltages to 5.5 V

7.4 Device Functional Modes

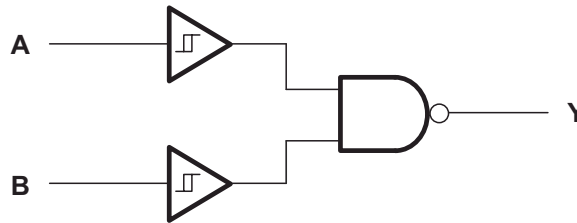
表 7-1. Function Table
(Each Gate)

INPUTS		OUTPUT Y
A	B	
H	H	L
L	X	H
X	L	H

8 Application and Implementation

备注

以下应用部分中的信息不属于 TI 器件规格的范围，TI 不担保其准确性和完整性。TI 的客户应负责确定器件是否适用于其应用。客户应验证并测试其设计，以确保系统功能。

8.1 Application Information

The SN74AHC132 is a low-drive CMOS device that can be used for a multitude of bus interface type applications where output ringing is a concern. The low drive and slow edge rates will minimize overshoot and undershoot on the outputs. The inputs can accept voltages to 5.5 V at any valid V_{CC} , thus making the device an excellent choice for down translation.

8.2 Typical Application



图 8-1. Typical Application Schematic

8.2.1 Design Requirements

This device uses CMOS technology and has balanced output drive. Take care to avoid bus contention because it can drive currents that would exceed maximum limits. The high drive will also create fast edges into light loads, so routing and load conditions should be considered to prevent ringing.

8.2.2 Detailed Design Procedure

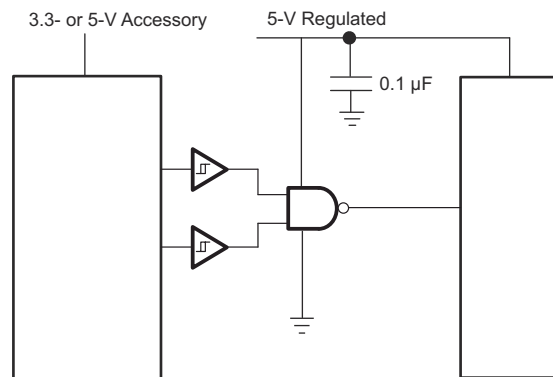
- Recommended input conditions:
 - For rise time and fall time specifications, see $\Delta t / \Delta V$ in the [Recommended Operating Conditions](#) table.
 - For specified high and low levels, see V_{IH} and V_{IL} in the [Recommended Operating Conditions](#) table.
 - Inputs are overvoltage tolerant allowing them to go as high as 5.5 V at any valid V_{CC} .
- Recommend output conditions:
 - Load currents should not exceed 25 mA per output and 50 mA total for the part.
 - Outputs should not be pulled above V_{CC} .

8.2.3 Application Curves

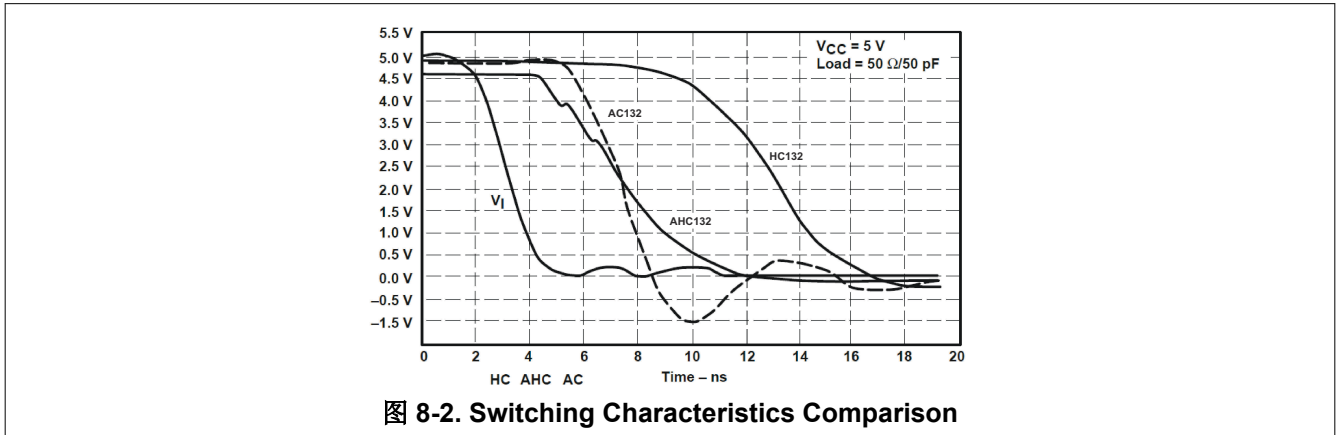

8.3 Power Supply Recommendations

The power supply can be any voltage between the MIN and MAX supply-voltage rating located in the [Recommended Operating Conditions](#) table.

Each V_{CC} pin should have a good bypass capacitor to prevent power disturbance. For devices with a single supply, $0.1 \mu F$ is recommended. If there are multiple V_{CC} pins, then a $0.01 \mu F$ or a $0.022 \mu F$ is recommended for each power pin. It is acceptable to parallel multiple bypass capacitors to reject different frequencies of noise. A $0.1 \mu F$ and a $1 \mu F$ are commonly used in parallel. Install the bypass capacitor as close to the power pin as possible for best results.

8.4 Layout

8.4.1 Layout Guidelines

When using multiple bit logic devices, inputs should not float. In many cases, functions or parts of functions of digital logic devices are unused. Some examples are when only two inputs of a triple-input AND gate are used, or when only 3 of the 4-buffer gates are used. Such input pins should not be left unconnected because the undefined voltages at the outside connections result in undefined operational states.

Specified in the [Layout Examples](#) are rules that must be observed under all circumstances. All unused inputs of digital logic devices must be connected to a high or low bias to prevent them from floating. The logic level that should be applied to any particular unused input depends on the function of the device. Generally they will be tied to GND or V_{CC} , whichever makes more sense or is more convenient. It is acceptable to float outputs unless the part is a transceiver. If the transceiver has an output enable pin, then it will disable the outputs section of the part when asserted. This will not disable the input section of the I/Os so they also cannot float when disabled.

8.4.2 Layout Example



图 8-3. Layout Diagram

9 Device and Documentation Support

9.1 Documentation Support (Analog)

9.1.1 Related Documentation

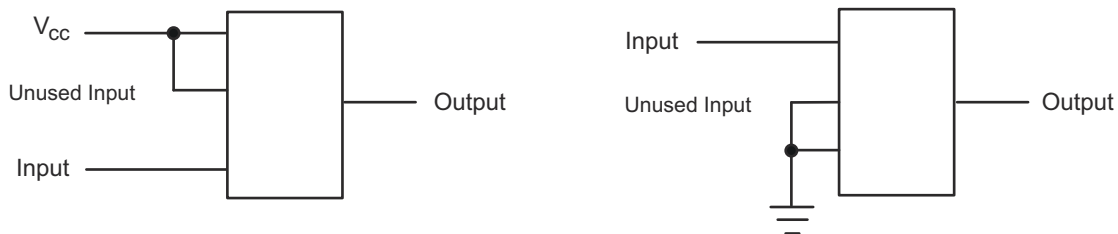
For related documentation, see the following:

- Texas Instruments, [CMOS Power Consumption and Cpd Calculation application note](#)
- Texas Instruments, [Designing With Logic application note](#)
- Texas Instruments, [Thermal Characteristics of Standard Linear and Logic \(SLL\) Packages and Devices application note](#)
- Texas Instruments, [Implications of Slow or Floating CMOS Inputs application note](#)

9.2 接收文档更新通知

要接收文档更新通知，请导航至 ti.com 上的器件产品文件夹。点击 [通知](#) 进行注册，即可每周接收产品信息更改摘要。有关更改的详细信息，请查看任何已修订文档中包含的修订历史记录。

9.3 支持资源

[TI E2E™ 中文支持论坛](#) 是工程师的重要参考资料，可直接从专家处获得快速、经过验证的解答和设计帮助。搜索现有解答或提出自己的问题，获得所需的快速设计帮助。

链接的内容由各个贡献者“按原样”提供。这些内容并不构成 TI 技术规范，并且不一定反映 TI 的观点；请参阅 TI 的 [使用条款](#)。

9.4 Trademarks

TI E2E™ is a trademark of Texas Instruments.

所有商标均为其各自所有者的财产。

9.5 静电放电警告



静电放电 (ESD) 会损坏这个集成电路。德州仪器 (TI) 建议通过适当的预防措施处理所有集成电路。如果不遵守正确的处理和安装程序，可能会损坏集成电路。

ESD 的损坏小至导致微小的性能降级，大至整个器件故障。精密的集成电路可能更容易受到损坏，这是因为非常细微的参数更改都可能会导致器件与其发布的规格不相符。

9.6 术语表

[TI 术语表](#) 本术语表列出并解释了术语、首字母缩略词和定义。

10 Revision History

Changes from Revision J (October 2023) to Revision K (February 2024) Page

- | | |
|--|---|
| • 删除了 <i>特性</i> 中的机器放电模型..... | 1 |
| • Updated thermal values for D package from R ^θ JA = 90.6 to 124.6, R ^θ JC(top) = 50.9 to 79.7, R ^θ JB = 44.8 to 81.2, Ψ JT = 14.7 to 39.3, Ψ JB = 44.5 to 80.8, R ^θ JC(bot) = N/A, all values in °C/W | 5 |

Changes from Revision I (August 2023) to Revision J (October 2023) Page

- | | |
|---|---|
| • Updated thermal values for PW package from R ^θ JA = 122.6 to 147.7, R ^θ JC(top) = 51.4 to 77.4, R ^θ JB = 64.4 to 90.9, Ψ JT = 6.7 to 27.2, Ψ JB = 63.8 to 90.2, all values in °C/W | 5 |
|---|---|

11 Mechanical, Packaging, and Orderable Information

The following pages include mechanical, packaging, and orderable information. This information is the most current data available for the designated devices. This data is subject to change without notice and revision of this document. For browser-based versions of this data sheet, refer to the left-hand navigation.

PACKAGING INFORMATION

Orderable Device	Status (1)	Package Type	Package Drawing	Pins	Package Qty	Eco Plan (2)	Lead finish/ Ball material (6)	MSL Peak Temp (3)	Op Temp (°C)	Device Marking (4/5)	Samples
SN74AHC132BQAR	ACTIVE	WQFN	BQA	14	3000	RoHS & Green	NIPDAU	Level-1-260C-UNLIM	-40 to 125	AHC132	Samples
SN74AHC132D	OBSOLETE	SOIC	D	14		TBD	Call TI	Call TI	-40 to 125	AHC132	
SN74AHC132DBR	ACTIVE	SSOP	DB	14	2000	RoHS & Green	NIPDAU	Level-1-260C-UNLIM	-40 to 125	HA132	Samples
SN74AHC132DGVR	ACTIVE	TVSOP	DGV	14	2000	RoHS & Green	NIPDAU	Level-1-260C-UNLIM	-40 to 125	HA132	Samples
SN74AHC132DR	ACTIVE	SOIC	D	14	2500	RoHS & Green	NIPDAU	Level-1-260C-UNLIM	-40 to 125	AHC132	Samples
SN74AHC132N	ACTIVE	PDIP	N	14	25	RoHS & Green	NIPDAU	N / A for Pkg Type	-40 to 125	SN74AHC132N	Samples
SN74AHC132NSR	ACTIVE	SOP	NS	14	2000	RoHS & Green	NIPDAU	Level-1-260C-UNLIM	-40 to 125	AHC132	Samples
SN74AHC132PW	OBSOLETE	TSSOP	PW	14		TBD	Call TI	Call TI	-40 to 125	HA132	
SN74AHC132PWR	ACTIVE	TSSOP	PW	14	2000	RoHS & Green	NIPDAU SN	Level-1-260C-UNLIM	-40 to 125	HA132	Samples
SN74AHC132RGYR	ACTIVE	VQFN	RGY	14	3000	RoHS & Green	NIPDAU	Level-2-260C-1 YEAR	-40 to 125	HA132	Samples

(1) The marketing status values are defined as follows:

ACTIVE: Product device recommended for new designs.

LIFEBUY: TI has announced that the device will be discontinued, and a lifetime-buy period is in effect.

NRND: Not recommended for new designs. Device is in production to support existing customers, but TI does not recommend using this part in a new design.

PREVIEW: Device has been announced but is not in production. Samples may or may not be available.

OBSOLETE: TI has discontinued the production of the device.

(2) **RoHS:** TI defines "RoHS" to mean semiconductor products that are compliant with the current EU RoHS requirements for all 10 RoHS substances, including the requirement that RoHS substance do not exceed 0.1% by weight in homogeneous materials. Where designed to be soldered at high temperatures, "RoHS" products are suitable for use in specified lead-free processes. TI may reference these types of products as "Pb-Free".

RoHS Exempt: TI defines "RoHS Exempt" to mean products that contain lead but are compliant with EU RoHS pursuant to a specific EU RoHS exemption.

Green: TI defines "Green" to mean the content of Chlorine (Cl) and Bromine (Br) based flame retardants meet JS709B low halogen requirements of <=1000ppm threshold. Antimony trioxide based flame retardants must also meet the <=1000ppm threshold requirement.

(3) MSL, Peak Temp. - The Moisture Sensitivity Level rating according to the JEDEC industry standard classifications, and peak solder temperature.

(4) There may be additional marking, which relates to the logo, the lot trace code information, or the environmental category on the device.

⁽⁵⁾ Multiple Device Markings will be inside parentheses. Only one Device Marking contained in parentheses and separated by a "~" will appear on a device. If a line is indented then it is a continuation of the previous line and the two combined represent the entire Device Marking for that device.

⁽⁶⁾ Lead finish/Ball material - Orderable Devices may have multiple material finish options. Finish options are separated by a vertical ruled line. Lead finish/Ball material values may wrap to two lines if the finish value exceeds the maximum column width.

Important Information and Disclaimer:The information provided on this page represents TI's knowledge and belief as of the date that it is provided. TI bases its knowledge and belief on information provided by third parties, and makes no representation or warranty as to the accuracy of such information. Efforts are underway to better integrate information from third parties. TI has taken and continues to take reasonable steps to provide representative and accurate information but may not have conducted destructive testing or chemical analysis on incoming materials and chemicals. TI and TI suppliers consider certain information to be proprietary, and thus CAS numbers and other limited information may not be available for release.

In no event shall TI's liability arising out of such information exceed the total purchase price of the TI part(s) at issue in this document sold by TI to Customer on an annual basis.

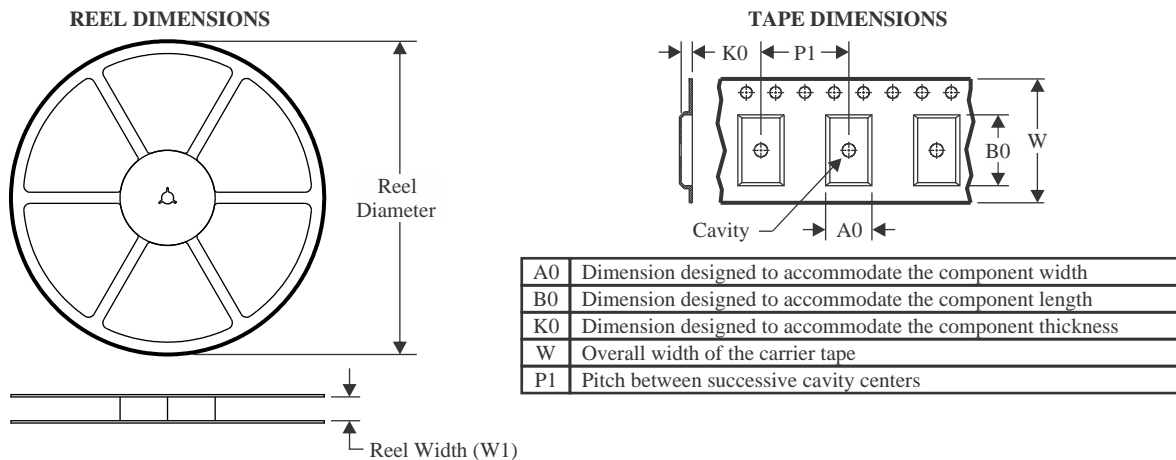
TAPE AND REEL INFORMATION

QUADRANT ASSIGNMENTS FOR PIN 1 ORIENTATION IN TAPE

*All dimensions are nominal

Device	Package Type	Package Drawing	Pins	SPQ	Reel Diameter (mm)	Reel Width W1 (mm)	A0 (mm)	B0 (mm)	K0 (mm)	P1 (mm)	W (mm)	Pin1 Quadrant
SN74AHC132BQAR	WQFN	BQA	14	3000	180.0	12.4	2.8	3.3	1.1	4.0	12.0	Q1
SN74AHC132DBR	SSOP	DB	14	2000	330.0	16.4	8.35	6.6	2.4	12.0	16.0	Q1
SN74AHC132DGVR	TVSOP	DGV	14	2000	330.0	12.4	6.8	4.0	1.6	8.0	12.0	Q1
SN74AHC132DR	SOIC	D	14	2500	330.0	16.4	6.5	9.0	2.1	8.0	16.0	Q1
SN74AHC132DR	SOIC	D	14	2500	330.0	12.4	3.75	3.75	1.15	8.0	12.0	Q1
SN74AHC132DR	SOIC	D	14	2500	330.0	16.4	6.5	9.0	2.1	8.0	16.0	Q1
SN74AHC132NSR	SOP	NS	14	2000	330.0	16.4	8.2	10.5	2.5	12.0	16.0	Q1
SN74AHC132PWR	TSSOP	PW	14	2000	330.0	12.4	6.9	5.6	1.6	8.0	12.0	Q1
SN74AHC132PWR	TSSOP	PW	14	2000	330.0	12.4	6.9	5.6	1.6	8.0	12.0	Q1
SN74AHC132RGYR	VQFN	RGY	14	3000	330.0	12.4	3.75	3.75	1.15	8.0	12.0	Q1

TAPE AND REEL BOX DIMENSIONS



*All dimensions are nominal

Device	Package Type	Package Drawing	Pins	SPQ	Length (mm)	Width (mm)	Height (mm)
SN74AHC132BQAR	WQFN	BQA	14	3000	210.0	185.0	35.0
SN74AHC132DBR	SSOP	DB	14	2000	356.0	356.0	35.0
SN74AHC132DGVR	TVSOP	DGV	14	2000	356.0	356.0	35.0
SN74AHC132DR	SOIC	D	14	2500	356.0	356.0	35.0
SN74AHC132DR	SOIC	D	14	2500	340.5	336.1	32.0
SN74AHC132DR	SOIC	D	14	2500	353.0	353.0	32.0
SN74AHC132NSR	SOP	NS	14	2000	356.0	356.0	35.0
SN74AHC132PWR	TSSOP	PW	14	2000	356.0	356.0	35.0
SN74AHC132PWR	TSSOP	PW	14	2000	353.0	353.0	32.0
SN74AHC132RGYR	VQFN	RGY	14	3000	356.0	356.0	35.0

TUBE

*All dimensions are nominal

Device	Package Name	Package Type	Pins	SPQ	L (mm)	W (mm)	T (μm)	B (mm)
SN74AHC132N	N	PDIP	14	25	506	13.97	11230	4.32
SN74AHC132N	N	PDIP	14	25	506	13.97	11230	4.32

重要通知和免责声明

TI“按原样”提供技术和可靠性数据（包括数据表）、设计资源（包括参考设计）、应用或其他设计建议、网络工具、安全信息和其他资源，不保证没有瑕疵且不做任何明示或暗示的担保，包括但不限于对适销性、某特定用途方面的适用性或不侵犯任何第三方知识产权的暗示担保。

这些资源可供使用 TI 产品进行设计的熟练开发人员使用。您将自行承担以下全部责任：(1) 针对您的应用选择合适的 TI 产品，(2) 设计、验证并测试您的应用，(3) 确保您的应用满足相应标准以及任何其他功能安全、信息安全、监管或其他要求。

这些资源如有变更，恕不另行通知。TI 授权您仅可将这些资源用于研发本资源所述的 TI 产品的相关应用。严禁以其他方式对这些资源进行复制或展示。您无权使用任何其他 TI 知识产权或任何第三方知识产权。您应全额赔偿因在这些资源的使用中对 TI 及其代表造成的任何索赔、损害、成本、损失和债务，TI 对此概不负责。

TI 提供的产品受 [TI 的销售条款](#) 或 [ti.com](#) 上其他适用条款/TI 产品随附的其他适用条款的约束。TI 提供这些资源并不会扩展或以其他方式更改 TI 针对 TI 产品发布的适用的担保或担保免责声明。

TI 反对并拒绝您可能提出的任何其他或不同的条款。

邮寄地址：Texas Instruments, Post Office Box 655303, Dallas, Texas 75265
版权所有 © 2025，德州仪器 (TI) 公司