

SN74AVC8T245-Q1 具有可配置电压转换和三态输出的 汽车类 8 位双电源总线收发器

1 特性

- 符合汽车应用要求
- AEC Q100 测试指导结果如下：
 - 器件温度等级 1：-40°C 至 +125°C 环境温度工作温度范围
 - 器件人体放电模型 (HBM) 静电防护 (ESD) 分类等级 H2
 - 器件 CDM ESD 分类等级 C3B
- 控制输入 V_{IH} 和 V_{IL} 电平以 V_{CCA} 电压为基准
- V_{CC} 隔离特性 - 如果任何一个 V_{CC} 输入接地 (GND)，则所有 I/O 端口均处于高阻抗状态
- I_{off} 支持局部断电模式运行
- 完全可配置的双轨设计，支持各个端口在 1.4V 至 3.6V 的整个电源电压范围内运行
- I/O 可承受 4.6V 的电压
- 最大数据速率：
 - 170Mbps ($V_{CCA} < 1.8V$ 或 $V_{CCB} < 1.8V$)
 - 320Mbps ($V_{CCA} \geq 1.8V$ 和 $V_{CCB} \geq 1.8V$)
- 闩锁性能超过 100mA，符合 JESD 78 II 类规范的要求

2 应用

- 远程信息处理
- 仪表组
- 音响主机
- 导航系统

3 说明

SN74AVC8T245-Q1 是一款采用两个独立可配置电源轨的 8 位同相总线收发器。SN74AVC8T245-Q1 在 V_{CCA} 和 V_{CCB} 设置为 1.4V 至 3.6V 时运行效果最佳。该器件可在 V_{CCA} 和 V_{CCB} 低至 1.2V 时正常运行。A 端口旨在跟踪 V_{CCA} 。 V_{CCA} 支持从 1.2V 到 3.6V 范围内的任一电源电压。B 端口旨在跟踪 V_{CCB} 。 V_{CCB} 可接受 1.2V 到 3.6V 范围内的任意电源电压，因此可在 1.2V、1.5V、1.8V、2.5V 和 3.3V 电压节点之间任意进行通用低压双向转换。

SN74AVC8T245-Q1 设计可实现数据总线间的异步通信。根据方向控制 (DIR) 输入上的逻辑电平，此器件将数据从 A 总线发送至 B 总线，或者将数据从 B 总线发送至 A 总线。可以使用输出使能 (\overline{OE}) 输入来禁用输出，这样可有效隔离总线。

在 SN74AVC8T245-Q1 设计中， V_{CCA} 为控制引脚 (DIR 和 \overline{OE}) 供电。

该器件规格涵盖使用 I_{off} 的部分断电应用。当器件断电时， I_{off} 电路将会禁用输出。这会抑制电流反流到器件中，从而防止损坏器件。

V_{CC} 隔离特性可确保只要有任何一个 V_{CC} 输入接地 (GND)，两个端口均处于高阻抗状态。

要在上电或断电期间将器件置于高阻抗状态，应通过一个上拉电阻器将 \overline{OE} 连接至 V_{CC} ；该电阻器的最小值由驱动器的电流灌入能力决定。

封装信息

器件型号	封装 ⁽¹⁾	封装尺寸 ⁽²⁾
SN74AVC8T245-Q1	RHL (VQFN, 24)	5.5mm x 3.5mm
	PW (TSSOP, 24)	7.8mm x 6.4mm

(1) 有关详细信息，请参阅节 11。

(2) 封装尺寸 (长 x 宽) 为标称值，并包括引脚 (如适用)。

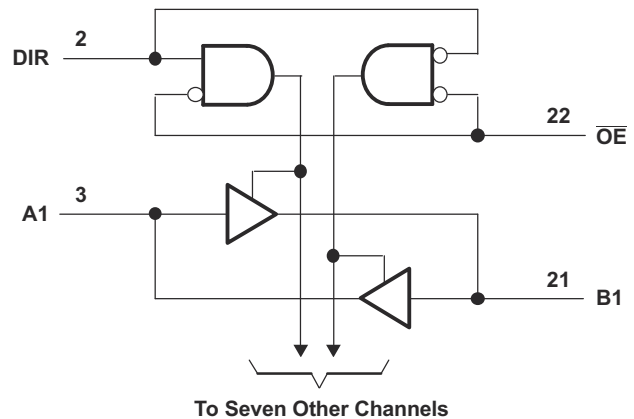

逻辑图 (正逻辑)

Table of Contents

1 特性	1	7 Detailed Description	17
2 应用	1	7.1 Overview.....	17
3 说明	1	7.2 Functional Block Diagram.....	17
4 Pin Configuration and Functions	3	7.3 Feature Description.....	17
5 Specifications	4	7.4 Device Functional Modes.....	17
5.1 Absolute Maximum Ratings.....	4	8 Application and Implementation	18
5.2 ESD Ratings.....	4	8.1 Application Information.....	18
5.3 Recommended Operating Conditions.....	5	8.2 Typical Application.....	18
5.4 Thermal Information.....	6	8.3 Power Supply Recommendations.....	19
5.5 Electrical Characteristics.....	6	8.4 Layout.....	20
5.6 Switching Characteristics: $V_{CCA} = 1.2\text{ V}$	7	9 Device and Documentation Support	21
5.7 Switching Characteristics: $V_{CCA} = 1.5\text{ V} \pm 0.1\text{ V}$	8	9.1 Documentation Support.....	21
5.8 Switching Characteristics: $V_{CCA} = 1.8\text{ V} \pm 0.15\text{ V}$	9	9.2 接收文档更新通知.....	21
5.9 Switching Characteristics: $V_{CCA} = 2.5\text{ V} \pm 0.2\text{ V}$	10	9.3 支持资源.....	21
5.10 Switching Characteristics: $V_{CCA} = 3.3\text{ V} \pm 0.3\text{ V}$	10	9.4 Trademarks.....	21
5.11 Operating Characteristics.....	12	9.5 静电放电警告.....	21
5.12 Typical Total Static Current Consumption (I_{CCA} + I_{CCB}).....	13	9.6 术语表.....	21
5.13 Typical Characteristics.....	14	10 Revision History	21
6 Parameter Measurement Information	16	11 Mechanical, Packaging, and Orderable Information	22

4 Pin Configuration and Functions



图 4-1. RHL Package, 24-Pin VQFN (Top View)



图 4-2. PW Package, 24-Pin TSSOP (Top View)

表 4-1. Pin Functions

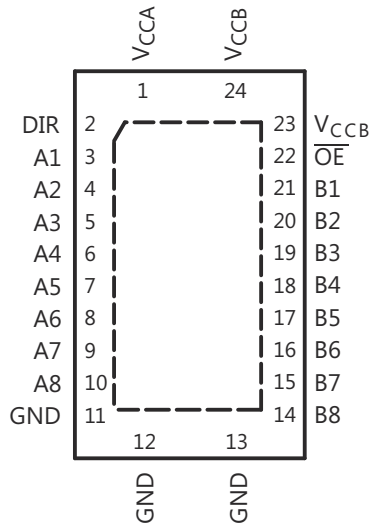
PIN			TYPE ⁽¹⁾	DESCRIPTION
NAME	VQFN	TSSOP		
A1	3	3	I/O	Input/output A1. Referenced to V_{CCA} .
A2	4	4	I/O	Input/output A2. Referenced to V_{CCA} .
A3	5	5	I/O	Input/output A3. Referenced to V_{CCA} .
A4	6	6	I/O	Input/output A4. Referenced to V_{CCA} .
A5	7	7	I/O	Input/output A5. Referenced to V_{CCA} .
A6	8	8	I/O	Input/output A6. Referenced to V_{CCA} .
A7	9	9	I/O	Input/output A7. Referenced to V_{CCA} .
A8	10	10	I/O	Input/output A8. Referenced to V_{CCA} .
B1	21	21	I/O	Input/output B1. Referenced to V_{CCB} .
B2	20	20	I/O	Input/output B2. Referenced to V_{CCB} .
B3	19	19	I/O	Input/output B3. Referenced to V_{CCB} .
B4	18	18	I/O	Input/output B4. Referenced to V_{CCB} .
B5	17	17	I/O	Input/output B5. Referenced to V_{CCB} .
B6	16	16	I/O	Input/output B6. Referenced to V_{CCB} .
B7	15	15	I/O	Input/output B7. Referenced to V_{CCB} .
B8	14	14	I/O	Input/output B8. Referenced to V_{CCB} .
DIR	2	—	I	Direction-control input for 1 ports
GND	12, 13	11, 12, 13	—	Ground
OE	22	22	I	3-state output-mode enable. Pull \overline{OE} high to place '2' outputs in 3-state mode. Referenced to V_{CCA} .
V_{CCA}	1	1	—	A-port power supply voltage. $1.2\text{ V} \leq V_{CCA} \leq 3.6\text{ V}$
V_{CCB}	23, 24	23, 24	—	B-port power supply voltage. $1.2\text{ V} \leq V_{CCB} \leq 3.6\text{ V}$
Thermal pad			—	The exposed thermal pad must be connected as a secondary GND or be left electrically open.

(1) I = input, O = output

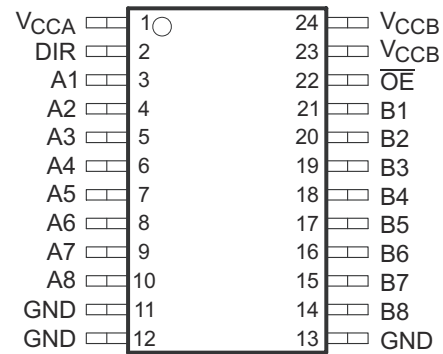
5 Specifications

5.1 Absolute Maximum Ratings

over operating free-air temperature range (unless otherwise noted)⁽¹⁾

		MIN	MAX	UNIT	
V_{CCA}	Supply voltage	- 0.5	4.6	V	
V_{CCB}					
V_I	Input voltage ⁽²⁾	I/O ports (A port)	- 0.5	4.6	V
		I/O ports (B port)	- 0.5	4.6	V
		Control inputs	- 0.5	4.6	V
V_O	Voltage range applied to any output in the high-impedance or power-off state ⁽²⁾	A port	- 0.5	4.6	V
		B port	- 0.5	4.6	V
V_O	Voltage range applied to any output in the high or low state ^{(2) (3)}	A port	- 0.5	$(V_{CCA} + 0.5)$	V
		B port	- 0.5	$(V_{CCB} + 0.5)$	V
I_{IK}	Input clamp current	$V_I < 0$	- 50	mA	
I_{OK}	Output clamp current	$V_O < 0$	- 50	mA	
I_O	Continuous output current		± 50	mA	
	Continuous current through V_{CCA} , V_{CCB} , or GND		± 100	mA	
T_J	Junction temperature		150	°C	
T_{stg}	Storage temperature		- 65	150	°C

- (1) Stresses beyond those listed under *Absolute Maximum Ratings* may cause permanent damage to the device. These are stress ratings only, and functional operation of the device at these or any other conditions beyond those indicated under *Recommended Operating Conditions* is not implied. Exposure to absolute-maximum-rated conditions for extended periods may affect device reliability.
- (2) The device withstands voltages in excess of input voltage and output negative-voltage ratings while operating within the input and output current ratings.
- (3) The device withstands voltages in excess of the output positive-voltage rating up to 4.6 V maximum while operating within the output current rating.

5.2 ESD Ratings

		VALUE	UNIT
$V_{(ESD)}$	Electrostatic discharge	Human-body model (HBM), per AEC Q100-002 Classification Level H2 ⁽¹⁾	± 2000
		Charged-device model (CDM), per AEC Q100-011 Classification Level C3B	± 750

- (1) AEC Q100-002 indicates that HBM stressing shall be in accordance with the ANSI/ESDA/JEDEC JS-001 specification.

5.3 Recommended Operating Conditions

See (1) (2) (3)

			V _{CCI}	V _{CCO}	MIN	MAX	UNIT
V _{CCA}	Supply voltage				1.2	3.6	V
V _{CCB}	Supply voltage				1.2	3.6	V
V _{IH}	High-level input voltage	Data inputs	1.2 V to 1.95 V		V _{CCI} × 0.65		V
			1.95 V to 2.7 V		1.6		
			2.7 V to 3.6 V		2		
V _{IL}	Low-level input voltage	Data inputs	1.2 V to 1.95 V		V _{CCI} × 0.35		V
			1.95 V to 2.7 V		0.7		
			2.7 V to 3.6 V		0.8		
V _{IH}	High-level input voltage	DIR (referenced to V _{CCA})	1.2 V to 1.95 V		V _{CCA} × 0.65		V
			1.95 V to 2.7 V		1.6		
			2.7 V to 3.6 V		2		
V _{IL}	Low-level input voltage	DIR (referenced to V _{CCA})	1.2 V to 1.95 V		V _{CCA} × 0.35		V
			1.95 V to 2.7 V		0.7		
			2.7 V to 3.6 V		0.8		
V _I	Input voltage				0	3.6	V
V _O	Output voltage	Active state			0	V _{CCO}	V
		3-state			0	3.6	V
I _{OH}	High-level output current			1.2 V		-3	mA
				1.4 V to 1.6 V		-6	
				1.65 V to 1.95 V		-8	
				2.3 V to 2.7 V		-9	
				3 V to 3.6 V		-12	
I _{OL}	Low-level output current			1.2 V		3	mA
				1.4 V to 1.6 V		6	
				1.65 V to 1.95 V		8	
				2.3 V to 2.7 V		9	
				3 V to 3.6 V		12	
Δt / Δv	Input transition rise or fall rate					5	ns / V
T _A	Operating free-air temperature				-40	125	°C

- (1) V_{CCI} is the V_{CC} associated with the input port.
- (2) V_{CCO} is the V_{CC} associated with the output port.
- (3) Hold all unused data inputs of the device at V_{CCI} or GND for proper device operation. See the TI application report, [Implications of Slow or Floating CMOS Inputs](#), SCBA004.

5.4 Thermal Information

THERMAL METRIC		SN74AVC8T245-Q1		UNIT
		RHL (VQFN)	PW (TSSOP)	
		24 PINS	24 PINS	
$R_{\theta JA}$	Junction-to-ambient thermal resistance	36.8	93.1	°C/W
$R_{\theta JC(top)}$	Junction-to-case (top) thermal resistance	32.5	36.7	°C/W
$R_{\theta JB}$	Junction-to-board thermal resistance	15.7	48.4	°C/W
ψ_{JT}	Junction-to-top characterization parameter	0.7	93.1	°C/W
ψ_{JB}	Junction-to-board characterization parameter	15.6	48.0	°C/W
$R_{\theta JC(bot)}$	Junction-to-case (bottom) thermal resistance	5.6	N/A	°C/W

5.5 Electrical Characteristics

over recommended operating free-air temperature range (unless otherwise noted)^{(2) (1)}

PARAMETER		TEST CONDITIONS	V_{CCA}	V_{CCB}	T_A	MIN	TYP	MAX	UNIT	
V_{OH}		$V_I = V_{IH}$	1.2 V to 3.6 V	1.2 V to 3.6 V	$T_A = -40^\circ\text{C to } +125^\circ\text{C}$	$V_{CCO} - 0.2$	0.95	1	V	
										$I_{OH} = -100 \mu\text{A}$
										$I_{OH} = -3 \text{ mA}$
										$I_{OH} = -6 \text{ mA}$
										$I_{OH} = -8 \text{ mA}$
										$I_{OH} = -12 \text{ mA}$
V_{OL}		$V_I = V_{IL}$	1.2 V to 3.6 V	1.2 V to 3.6 V	$T_A = -40^\circ\text{C to } +125^\circ\text{C}$	0.2	0.15	0.35	V	
										$I_{OL} = 100 \mu\text{A}$
										$I_{OL} = 3 \text{ mA}$
										$I_{OL} = 6 \text{ mA}$
										$I_{OL} = 8 \text{ mA}$
										$I_{OL} = 12 \text{ mA}$
I_I	Control inputs	$V_I = V_{CCA}$ or GND	1.2 V to 3.6 V	1.2 V to 3.6 V	$T_A = 25^\circ\text{C}$	± 0.02 5	± 0.25	± 1	μA	
										$T_A = -40^\circ\text{C to } +125^\circ\text{C}$
I_{off}	A or B port	V_I or $V_O = 0$ to 3.6 V	0 V	0 V to 3.6 V	$T_A = 25^\circ\text{C}$	± 0.1	± 1	± 5	μA	
										$T_A = -40^\circ\text{C to } +125^\circ\text{C}$
			0 V to 3.6 V	0 V	$T_A = 25^\circ\text{C}$	± 0.1	± 1	± 5		
										$T_A = -40^\circ\text{C to } +125^\circ\text{C}$
$I_{OZ}^{(3)}$	A or B port	$V_O = V_{CCO}$ or GND, $V_I = V_{CCI}$ or GND, $\overline{OE} = V_{IH}$	3.6 V	3.6 V	$T_A = 25^\circ\text{C}$	± 0.5	± 2.5	± 5	μA	
										$T_A = -40^\circ\text{C to } +125^\circ\text{C}$

5.5 Electrical Characteristics (续)

over recommended operating free-air temperature range (unless otherwise noted)⁽²⁾ (1)

PARAMETER		TEST CONDITIONS	V _{CCA}	V _{CCB}	T _A	MIN	TYP	MAX	UNIT
I _{CCA}		V _I = V _{CC1} or GND ⁽³⁾ , I _O = 0	1.2 V to 3.6 V	1.2 V to 3.6 V	T _A = -40°C to +125°C			15	μA
			0 V	3.6 V	T _A = -40°C to +125°C		-2		
			3.6 V	0 V	T _A = -40°C to +125°C		15		
I _{CCB}		V _I = V _{CC1} or GND ⁽³⁾ , I _O = 0	1.2 V to 3.6 V	1.2 V to 3.6 V	T _A = -40°C to +125°C			15	μA
			0 V	3.6 V	T _A = -40°C to +125°C		15		
			3.6 V	0 V	T _A = -40°C to +125°C		-2		
I _{CCA} + I _{CCB}		V _I = V _{CC1} or GND, I _O = 0	1.2 V to 3.6 V	1.2 V to 3.6 V	T _A = -40°C to +125°C			25	μA
C _i	Control inputs	V _I = 3.3 V or GND	3.3 V	3.3 V	T _A = 25°C		3.5		pF
C _{io}	A or B port	V _O = 3.3 V or GND	3.3 V	3.3 V	T _A = 25°C		6		pF

- (1) V_{CC1} is the V_{CC} associated with the input port.
(2) V_{CC0} is the V_{CC} associated with the output port.
(3) For I/O ports, the parameter I_{OZ} includes the input leakage current.

5.6 Switching Characteristics: V_{CCA} = 1.2 V

over recommended operating free-air temperature range, V_{CCA} = 1.2 V (see 图 6-1)

PARAMETER	FROM (INPUT)	TO (OUTPUT)	V _{CCB}	TYP	UNIT
t _{PLH} , t _{PHL}	A	B	V _{CCB} = 1.2 V	3.1	ns
			V _{CCB} = 1.5 V	2.6	
			V _{CCB} = 1.8 V	2.5	
			V _{CCB} = 2.5 V	3	
			V _{CCB} = 3.3 V	3.5	
t _{PLH} , t _{PHL}	B	A	V _{CCB} = 1.2 V	3.1	ns
			V _{CCB} = 1.5 V	2.7	
			V _{CCB} = 1.8 V	2.5	
			V _{CCB} = 2.5 V	2.4	
			V _{CCB} = 3.3 V	2.3	
t _{PZH} , t _{PZL}	OE	A	V _{CCB} = 1.2 V	5.3	ns
			V _{CCB} = 1.5 V		
			V _{CCB} = 1.8 V		
			V _{CCB} = 2.5 V		
			V _{CCB} = 3.3 V		
t _{PZH} , t _{PZL}	OE	B	V _{CCB} = 1.2 V	5.1	ns
			V _{CCB} = 1.5 V	4	
			V _{CCB} = 1.8 V	3.5	
			V _{CCB} = 2.5 V	3.2	
			V _{CCB} = 3.3 V	3.1	

5.6 Switching Characteristics: $V_{CCA} = 1.2\text{ V}$ (续)

over recommended operating free-air temperature range, $V_{CCB} = 1.2\text{ V}$ (see 图 6-1)

PARAMETER	FROM (INPUT)	TO (OUTPUT)	V_{CCB}	TYP	UNIT
t_{PHZ}, t_{PLZ}	\overline{OE}	A	$V_{CCB} = 1.2\text{ V}$	4.8	ns
			$V_{CCB} = 1.5\text{ V}$		
			$V_{CCB} = 1.8\text{ V}$		
			$V_{CCB} = 2.5\text{ V}$		
			$V_{CCB} = 3.3\text{ V}$		
t_{PHZ}, t_{PLZ}	\overline{OE}	B	$V_{CCB} = 1.2\text{ V}$	4.7	ns
			$V_{CCB} = 1.5\text{ V}$	4	
			$V_{CCB} = 1.8\text{ V}$	4.1	
			$V_{CCB} = 2.5\text{ V}$	4.3	
			$V_{CCB} = 3.3\text{ V}$	5.1	

5.7 Switching Characteristics: $V_{CCA} = 1.5\text{ V} \pm 0.1\text{ V}$

over recommended operating free-air temperature range, $V_{CCB} = 1.5\text{ V} \pm 0.1\text{ V}$ (see 图 6-1)

PARAMETER	FROM (INPUT)	TO (OUTPUT)	V_{CCB}	MIN	TYP	MAX	UNIT
t_{PLH}, t_{PHL}	A	B	$V_{CCB} = 1.2\text{ V}$		3.1		ns
			$V_{CCB} = 1.5\text{ V} \pm 0.1\text{ V}$	0.5		14.7	
			$V_{CCB} = 1.8\text{ V} \pm 0.15\text{ V}$	0.5		13.3	
			$V_{CCB} = 2.5\text{ V} \pm 0.2\text{ V}$	0.5		13.9	
			$V_{CCB} = 3.3\text{ V} \pm 0.3\text{ V}$	0.5		17.2	
t_{PLH}, t_{PHL}	B	A	$V_{CCB} = 1.2\text{ V}$		3.1		ns
			$V_{CCB} = 1.5\text{ V} \pm 0.1\text{ V}$	0.5		14.7	
			$V_{CCB} = 1.8\text{ V} \pm 0.15\text{ V}$	0.5		14.2	
			$V_{CCB} = 2.5\text{ V} \pm 0.2\text{ V}$	0.5		13.5	
			$V_{CCB} = 3.3\text{ V} \pm 0.3\text{ V}$	0.5		13.2	
t_{PZH}, t_{PZL}	\overline{OE}	A	$V_{CCB} = 1.2\text{ V}$		5.3		ns
			$V_{CCB} = 1.5\text{ V} \pm 0.1\text{ V}$	0.5		20.5	
			$V_{CCB} = 1.8\text{ V} \pm 0.15\text{ V}$	0.5		20.5	
			$V_{CCB} = 2.5\text{ V} \pm 0.2\text{ V}$	0.5		20.5	
			$V_{CCB} = 3.3\text{ V} \pm 0.3\text{ V}$	0.5		20.5	
t_{PZH}, t_{PZL}	\overline{OE}	B	$V_{CCB} = 1.2\text{ V}$		5.1		ns
			$V_{CCB} = 1.5\text{ V} \pm 0.1\text{ V}$	0.5		18.6	
			$V_{CCB} = 1.8\text{ V} \pm 0.15\text{ V}$	0.5		17.7	
			$V_{CCB} = 2.5\text{ V} \pm 0.2\text{ V}$	0.5		15.1	
			$V_{CCB} = 3.3\text{ V} \pm 0.3\text{ V}$	0.5		14.4	
t_{PHZ}, t_{PLZ}	\overline{OE}	A	$V_{CCB} = 1.2\text{ V}$		4.8		ns
			$V_{CCB} = 1.5\text{ V} \pm 0.1\text{ V}$	0.5		20.3	
			$V_{CCB} = 1.8\text{ V} \pm 0.15\text{ V}$	0.5		20.3	
			$V_{CCB} = 2.5\text{ V} \pm 0.2\text{ V}$	0.5		20.3	
			$V_{CCB} = 3.3\text{ V} \pm 0.3\text{ V}$	0.5		20.3	

5.7 Switching Characteristics: $V_{CCA} = 1.5\text{ V} \pm 0.1\text{ V}$ (续)

over recommended operating free-air temperature range, $V_{CCA} = 1.5\text{ V} \pm 0.1\text{ V}$ (see 图 6-1)

PARAMETER	FROM (INPUT)	TO (OUTPUT)	V_{CCB}	MIN	TYP	MAX	UNIT
t_{PHZ}, t_{PLZ}	\overline{OE}	B	$V_{CCB} = 1.2\text{ V}$		4.7		ns
			$V_{CCB} = 1.5\text{ V} \pm 0.1\text{ V}$	0.5		20.0	
			$V_{CCB} = 1.8\text{ V} \pm 0.15\text{ V}$	0.5		18.6	
			$V_{CCB} = 2.5\text{ V} \pm 0.2\text{ V}$	0.5		17.9	
			$V_{CCB} = 3.3\text{ V} \pm 0.3\text{ V}$	0.5		18.9	

5.8 Switching Characteristics: $V_{CCA} = 1.8\text{ V} \pm 0.15\text{ V}$

over recommended operating free-air temperature range, $V_{CCA} = 1.8\text{ V} \pm 0.15\text{ V}$ (see 图 6-1)

PARAMETER	FROM (INPUT)	TO (OUTPUT)	V_{CCB}	MIN	TYP	MAX	UNIT
t_{PLH}, t_{PHL}	A	B	$V_{CCB} = 1.2\text{ V}$		2.5		ns
			$V_{CCB} = 1.5\text{ V} \pm 0.1\text{ V}$	0.5		14.2	
			$V_{CCB} = 1.8\text{ V} \pm 0.15\text{ V}$	0.5		13.0	
			$V_{CCB} = 2.5\text{ V} \pm 0.2\text{ V}$	0.5		12.3	
			$V_{CCB} = 3.3\text{ V} \pm 0.3\text{ V}$	0.5		12.1	
t_{PLH}, t_{PHL}	B	A	$V_{CCB} = 1.2\text{ V}$		2.5		ns
			$V_{CCB} = 1.5\text{ V} \pm 0.1\text{ V}$	0.5		13.3	
			$V_{CCB} = 1.8\text{ V} \pm 0.15\text{ V}$	0.5		13.0	
			$V_{CCB} = 2.5\text{ V} \pm 0.2\text{ V}$	0.5		12.1	
			$V_{CCB} = 3.3\text{ V} \pm 0.3\text{ V}$	0.5		11.8	
t_{PZH}, t_{PZL}	\overline{OE}	A	$V_{CCB} = 1.2\text{ V}$		3		ns
			$V_{CCB} = 1.5\text{ V} \pm 0.1\text{ V}$	0.5		17.2	
			$V_{CCB} = 1.8\text{ V} \pm 0.15\text{ V}$	0.5		17.2	
			$V_{CCB} = 2.5\text{ V} \pm 0.2\text{ V}$	0.5		17.2	
			$V_{CCB} = 3.3\text{ V} \pm 0.3\text{ V}$	0.5		17.2	
t_{PZH}, t_{PZL}	\overline{OE}	B	$V_{CCB} = 1.2\text{ V}$		4.6		ns
			$V_{CCB} = 1.5\text{ V} \pm 0.1\text{ V}$	0.5		19.6	
			$V_{CCB} = 1.8\text{ V} \pm 0.15\text{ V}$	0.5		17.0	
			$V_{CCB} = 2.5\text{ V} \pm 0.2\text{ V}$	0.5		14.2	
			$V_{CCB} = 3.3\text{ V} \pm 0.3\text{ V}$	0.5		13.2	
t_{PHZ}, t_{PLZ}	\overline{OE}	A	$V_{CCB} = 1.2\text{ V}$		2.8		ns
			$V_{CCB} = 1.5\text{ V} \pm 0.1\text{ V}$	0.5		17.7	
			$V_{CCB} = 1.8\text{ V} \pm 0.15\text{ V}$	0.5		17.7	
			$V_{CCB} = 2.5\text{ V} \pm 0.2\text{ V}$	0.5		17.7	
			$V_{CCB} = 3.3\text{ V} \pm 0.3\text{ V}$	0.5		17.7	
t_{PHZ}, t_{PLZ}	\overline{OE}	B	$V_{CCB} = 1.2\text{ V}$		3.9		ns
			$V_{CCB} = 1.5\text{ V} \pm 0.1\text{ V}$	0.5		18.9	
			$V_{CCB} = 1.8\text{ V} \pm 0.15\text{ V}$	0.5		17.3	
			$V_{CCB} = 2.5\text{ V} \pm 0.2\text{ V}$	0.5		15.8	
			$V_{CCB} = 3.3\text{ V} \pm 0.3\text{ V}$	0.5		15.4	

5.9 Switching Characteristics: $V_{CCA} = 2.5 \text{ V} \pm 0.2 \text{ V}$

over recommended operating free-air temperature range, $V_{CCA} = 2.5 \text{ V} \pm 0.2 \text{ V}$ (see 图 6-1)

PARAMETER	FROM (INPUT)	TO (OUTPUT)	V_{CCB}	MIN	TYP	MAX	UNIT
t_{PLH} , t_{PHL}	A	B	$V_{CCB} = 1.2 \text{ V}$		2.4		ns
			$V_{CCB} = 1.5 \text{ V} \pm 0.1 \text{ V}$	0.5		13.5	
			$V_{CCB} = 1.8 \text{ V} \pm 0.15 \text{ V}$	0.5		12.1	
			$V_{CCB} = 2.5 \text{ V} \pm 0.2 \text{ V}$	0.5		10.7	
			$V_{CCB} = 3.3 \text{ V} \pm 0.3 \text{ V}$	0.5		10.2	
t_{PLH} , t_{PHL}	B	A	$V_{CCB} = 1.2 \text{ V}$		3		ns
			$V_{CCB} = 1.5 \text{ V} \pm 0.1 \text{ V}$	0.5		13.9	
			$V_{CCB} = 1.8 \text{ V} \pm 0.15 \text{ V}$	0.5		12.3	
			$V_{CCB} = 2.5 \text{ V} \pm 0.2 \text{ V}$	0.5		10.7	
			$V_{CCB} = 3.3 \text{ V} \pm 0.3 \text{ V}$	0.5		10.4	
t_{PZH} , t_{PZL}	$\overline{\text{OE}}$	A	$V_{CCB} = 1.2 \text{ V}$		2.2		ns
			$V_{CCB} = 1.5 \text{ V} \pm 0.1 \text{ V}$	0.5		13.7	
			$V_{CCB} = 1.8 \text{ V} \pm 0.15 \text{ V}$	0.5		13.7	
			$V_{CCB} = 2.5 \text{ V} \pm 0.2 \text{ V}$	0.5		13.7	
			$V_{CCB} = 3.3 \text{ V} \pm 0.3 \text{ V}$	0.5		13.7	
t_{PZH} , t_{PZL}	$\overline{\text{OE}}$	B	$V_{CCB} = 1.2 \text{ V}$		4.5		ns
			$V_{CCB} = 1.5 \text{ V} \pm 0.1 \text{ V}$	0.5		19.1	
			$V_{CCB} = 1.8 \text{ V} \pm 0.15 \text{ V}$	0.5		16.5	
			$V_{CCB} = 2.5 \text{ V} \pm 0.2 \text{ V}$	0.5		13.3	
			$V_{CCB} = 3.3 \text{ V} \pm 0.3 \text{ V}$	0.5		12.3	
t_{PHZ} , t_{PLZ}	$\overline{\text{OE}}$	A	$V_{CCB} = 1.2 \text{ V}$		1.8		ns
			$V_{CCB} = 1.5 \text{ V} \pm 0.1 \text{ V}$	0.5		14.2	
			$V_{CCB} = 1.8 \text{ V} \pm 0.15 \text{ V}$	0.5		14.2	
			$V_{CCB} = 2.5 \text{ V} \pm 0.2 \text{ V}$	0.5		14.2	
			$V_{CCB} = 3.3 \text{ V} \pm 0.3 \text{ V}$	0.5		14.2	
t_{PHZ} , t_{PLZ}	$\overline{\text{OE}}$	B	$V_{CCB} = 1.2 \text{ V}$		3.6		ns
			$V_{CCB} = 1.5 \text{ V} \pm 0.1 \text{ V}$	0.5		17.7	
			$V_{CCB} = 1.8 \text{ V} \pm 0.15 \text{ V}$	0.5		16.3	
			$V_{CCB} = 2.5 \text{ V} \pm 0.2 \text{ V}$	0.5		14.2	
			$V_{CCB} = 3.3 \text{ V} \pm 0.3 \text{ V}$	0.5		12.1	

5.10 Switching Characteristics: $V_{CCA} = 3.3 \text{ V} \pm 0.3 \text{ V}$

over recommended operating free-air temperature range, $V_{CCA} = 3.3 \text{ V} \pm 0.3 \text{ V}$ (see 图 6-1)

PARAMETER	FROM (INPUT)	TO (OUTPUT)	V_{CCB}	MIN	TYP	MAX	UNIT
t_{PLH} , t_{PHL}	A	B	$V_{CCB} = 1.2 \text{ V}$		2.3		ns
			$V_{CCB} = 1.5 \text{ V} \pm 0.1 \text{ V}$	0.5		13.2	
			$V_{CCB} = 1.8 \text{ V} \pm 0.15 \text{ V}$	0.5		11.1	
			$V_{CCB} = 2.5 \text{ V} \pm 0.2 \text{ V}$	0.5		10.4	
			$V_{CCB} = 3.3 \text{ V} \pm 0.3 \text{ V}$	0.5		9.7	

5.10 Switching Characteristics: $V_{CCA} = 3.3\text{ V} \pm 0.3\text{ V}$ (续)

over recommended operating free-air temperature range, $V_{CCB} = 3.3\text{ V} \pm 0.3\text{ V}$ (see 图 6-1)

PARAMETER	FROM (INPUT)	TO (OUTPUT)	V_{CCB}	MIN	TYP	MAX	UNIT
t_{PLH}, t_{PHL}	B	A	$V_{CCB} = 1.2\text{ V}$		3.5		ns
			$V_{CCB} = 1.5\text{ V} \pm 0.1\text{ V}$	0.5		17.2	
			$V_{CCB} = 1.8\text{ V} \pm 0.15\text{ V}$	0.5		12.1	
			$V_{CCB} = 2.5\text{ V} \pm 0.2\text{ V}$	0.5		10.2	
			$V_{CCB} = 3.3\text{ V} \pm 0.3\text{ V}$	0.5		9.7	
t_{PZH}, t_{PZL}	$\overline{\text{OE}}$	A	$V_{CCB} = 1.2\text{ V}$		2		ns
			$V_{CCB} = 1.5\text{ V} \pm 0.1\text{ V}$	0.5		12.3	
			$V_{CCB} = 1.8\text{ V} \pm 0.15\text{ V}$	0.5		12.3	
			$V_{CCB} = 2.5\text{ V} \pm 0.2\text{ V}$	0.5		12.3	
			$V_{CCB} = 3.3\text{ V} \pm 0.3\text{ V}$	0.5		12.3	
t_{PZH}, t_{PZL}	$\overline{\text{OE}}$	B	$V_{CCB} = 1.2\text{ V}$		4.5		ns
			$V_{CCB} = 1.5\text{ V} \pm 0.1\text{ V}$	0.5		18.9	
			$V_{CCB} = 1.8\text{ V} \pm 0.15\text{ V}$	0.5		16.1	
			$V_{CCB} = 2.5\text{ V} \pm 0.2\text{ V}$	0.5		13.2	
			$V_{CCB} = 3.3\text{ V} \pm 0.3\text{ V}$	0.5		12.3	
t_{PHZ}, t_{PLZ}	$\overline{\text{OE}}$	A	$V_{CCB} = 1.2\text{ V}$		1.7		ns
			$V_{CCB} = 1.5\text{ V} \pm 0.1\text{ V}$	0.5		12.3	
			$V_{CCB} = 1.8\text{ V} \pm 0.15\text{ V}$	0.5		12.3	
			$V_{CCB} = 2.5\text{ V} \pm 0.2\text{ V}$	0.5		12.3	
			$V_{CCB} = 3.3\text{ V} \pm 0.3\text{ V}$	0.5		12.3	
t_{PHZ}, t_{PLZ}	$\overline{\text{OE}}$	B	$V_{CCB} = 1.2\text{ V}$		3.4		ns
			$V_{CCB} = 1.5\text{ V} \pm 0.1\text{ V}$	0.5		17.4	
			$V_{CCB} = 1.8\text{ V} \pm 0.15\text{ V}$	0.5		15.8	
			$V_{CCB} = 2.5\text{ V} \pm 0.2\text{ V}$	0.5		13.7	
			$V_{CCB} = 3.3\text{ V} \pm 0.3\text{ V}$	0.5		12.6	

5.11 Operating Characteristics

 $T_A = 25^\circ\text{C}$

PARAMETER		TEST CONDITIONS	V _{CCA}	TYP	UNIT	
C _{pdA} ⁽¹⁾	A to B	Outputs enabled	C _L = 0, f = 10 MHz, t _r = t _f = 1 ns	V _{CCA} = V _{CCB} = 1.2 V	1	pF
			V _{CCA} = V _{CCB} = 1.5 V			
			V _{CCA} = V _{CCB} = 1.8 V			
			V _{CCA} = V _{CCB} = 2.5 V			
			V _{CCA} = V _{CCB} = 3.3 V			
	Outputs disabled	C _L = 0, f = 10 MHz, t _r = t _f = 1 ns	V _{CCA} = V _{CCB} = 1.2 V	1		
			V _{CCA} = V _{CCB} = 1.5 V			
			V _{CCA} = V _{CCB} = 1.8 V			
			V _{CCA} = V _{CCB} = 2.5 V			
			V _{CCA} = V _{CCB} = 3.3 V			
B to A	Outputs enabled	C _L = 0, f = 10 MHz, t _r = t _f = 1 ns	V _{CCA} = V _{CCB} = 1.2 V	12		
			V _{CCA} = V _{CCB} = 1.5 V	12		
			V _{CCA} = V _{CCB} = 1.8 V	12		
			V _{CCA} = V _{CCB} = 2.5 V	13		
			V _{CCA} = V _{CCB} = 3.3 V	14		
Outputs disabled	C _L = 0, f = 10 MHz, t _r = t _f = 1 ns	V _{CCA} = V _{CCB} = 1.2 V	1			
		V _{CCA} = V _{CCB} = 1.5 V				
		V _{CCA} = V _{CCB} = 1.8 V				
		V _{CCA} = V _{CCB} = 2.5 V				
		V _{CCA} = V _{CCB} = 3.3 V				
C _{pdB} ⁽¹⁾	A to B	Outputs enabled	C _L = 0, f = 10 MHz, t _r = t _f = 1 ns	V _{CCA} = V _{CCB} = 1.2 V	12	
				V _{CCA} = V _{CCB} = 1.5 V	12	
				V _{CCA} = V _{CCB} = 1.8 V	12	
				V _{CCA} = V _{CCB} = 2.5 V	13	
				V _{CCA} = V _{CCB} = 3.3 V	14	
	Outputs disabled	C _L = 0, f = 10 MHz, t _r = t _f = 1 ns	V _{CCA} = V _{CCB} = 1.2 V	1		
			V _{CCA} = V _{CCB} = 1.5 V			
			V _{CCA} = V _{CCB} = 1.8 V			
			V _{CCA} = V _{CCB} = 2.5 V			
			V _{CCA} = V _{CCB} = 3.3 V			
B to A	Outputs enabled	C _L = 0, f = 10 MHz, t _r = t _f = 1 ns	V _{CCA} = V _{CCB} = 1.2 V	1		
			V _{CCA} = V _{CCB} = 1.5 V			
			V _{CCA} = V _{CCB} = 1.8 V			
			V _{CCA} = V _{CCB} = 2.5 V			
			V _{CCA} = V _{CCB} = 3.3 V			
Outputs disabled	C _L = 0, f = 10 MHz, t _r = t _f = 1 ns	V _{CCA} = V _{CCB} = 1.2 V	1			
		V _{CCA} = V _{CCB} = 1.5 V				
		V _{CCA} = V _{CCB} = 1.8 V				
		V _{CCA} = V _{CCB} = 2.5 V				
		V _{CCA} = V _{CCB} = 3.3 V				

(1) Power dissipation capacitance per transceiver

5.12 Typical Total Static Current Consumption ($I_{CCA} + I_{CCB}$)

V_{CCB}	V_{CCA}						UNIT
	0 V	1.2 V	1.5 V	1.8 V	2.5 V	3.3 V	
0 V	0	<0.5	<0.5	<0.5	<0.5	<0.5	μ A
1.2 V	<0.5	<1	<1	<1	<1	1	μ A
1.5 V	<0.5	<1	<1	<1	<1	1	μ A
1.8 V	<0.5	<1	<1	<1	<1	<1	μ A
2.5 V	<0.5	1	<1	<1	<1	<1	μ A
3.3 V	<0.5	1	<1	<1	<1	<1	μ A

5.13 Typical Characteristics

T_A = 25°C



图 5-1. Typical Propagation Delay (A to B) vs Load Capacitance



图 5-2. Typical Propagation Delay (A to B) vs Load Capacitance

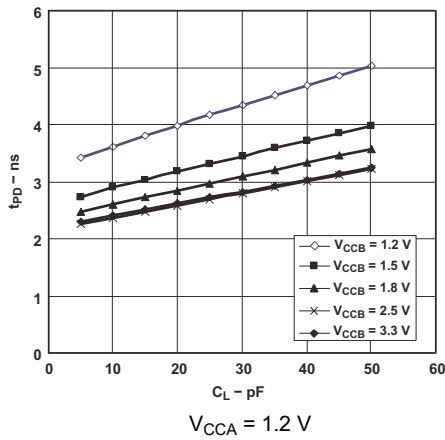

图 5-3. Typical Propagation Delay (A to B) vs Load Capacitance

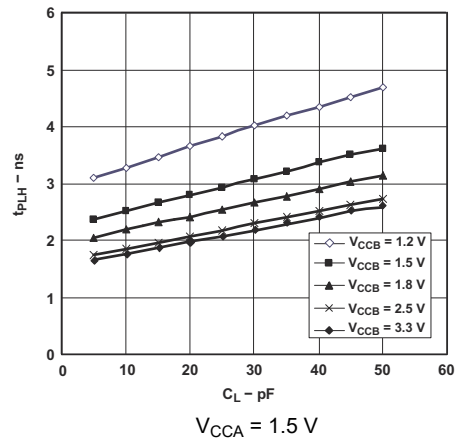

图 5-4. Typical Propagation Delay (A to B) vs Load Capacitance

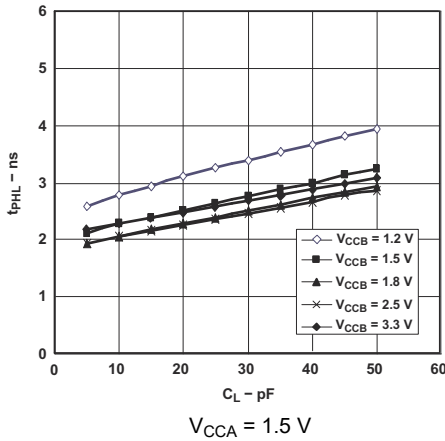

图 5-5. Typical Propagation Delay (A to B) vs Load Capacitance

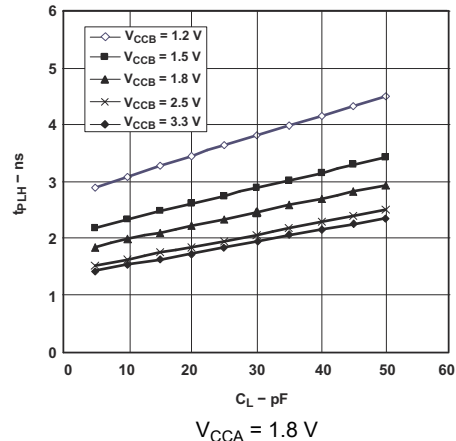

图 5-6. Typical Propagation Delay (A to B) vs Load Capacitance

5.13 Typical Characteristics (continued)

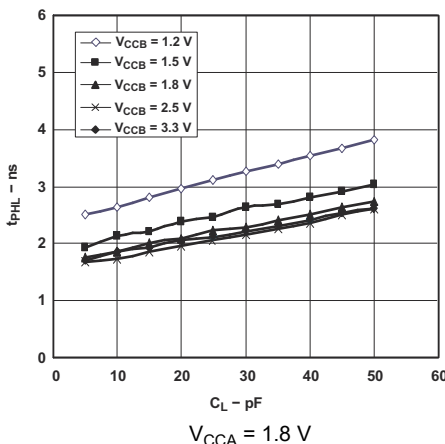
$T_A = 25^\circ\text{C}$

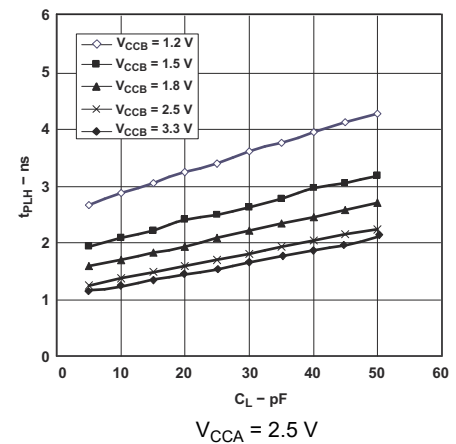

图 5-7. Typical Propagation Delay (A to B) vs Load Capacitance



图 5-8. Typical Propagation Delay (A to B) vs Load Capacitance

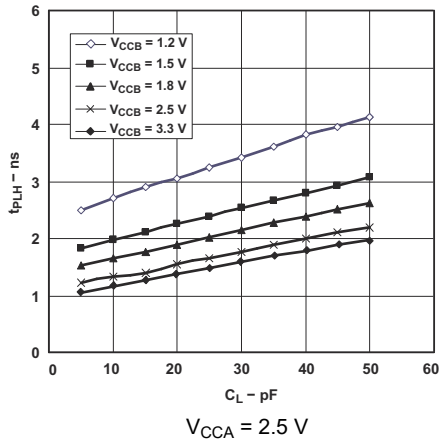

图 5-9. Typical Propagation Delay (A to B) vs Load Capacitance

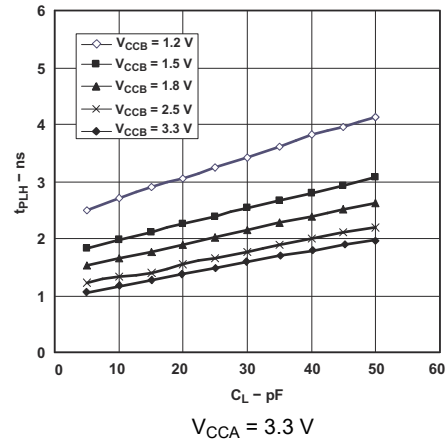

图 5-10. Low-Level Output Voltage (V_{OL}) vs Low-Level Current (I_{OL})

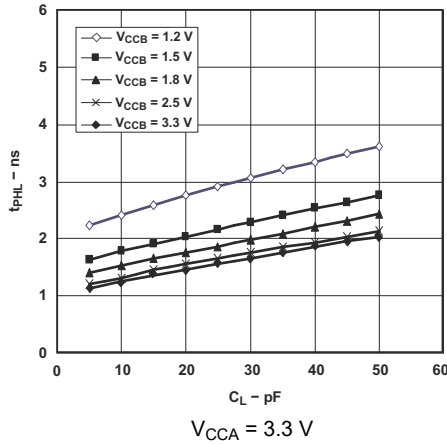

图 5-11. High-Level Output Voltage (V_{OH}) vs High-Level Current (I_{OH})

6 Parameter Measurement Information

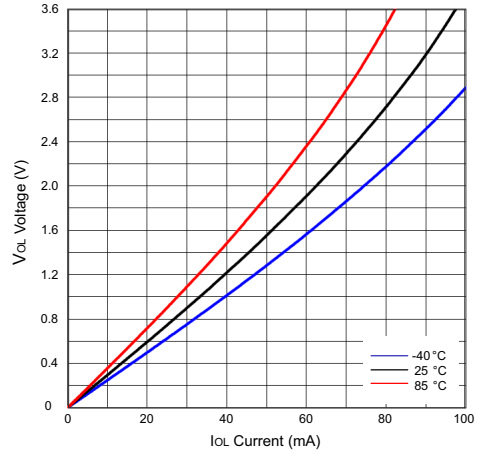

LOAD CIRCUIT

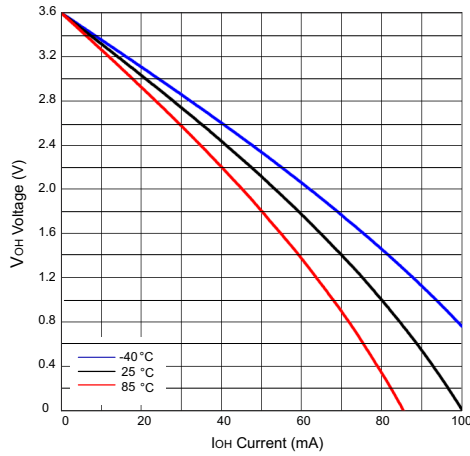
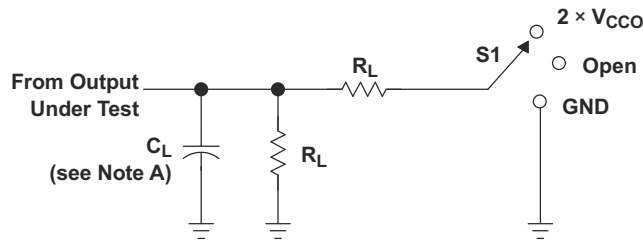
TEST	S1
t_{pd}	Open
t_{PLZ}/t_{PZL}	$2 \times V_{CCO}$
t_{PHZ}/t_{PZH}	GND

V_{CCO}	C_L	R_L	V_{TP}
1.2 V	15 pF	2 k Ω	0.1 V
1.5 V \pm 0.1 V	15 pF	2 k Ω	0.1 V
1.8 V \pm 0.15 V	15 pF	2 k Ω	0.15 V
2.5 V \pm 0.2 V	15 pF	2 k Ω	0.15 V
3.3 V \pm 0.3 V	15 pF	2 k Ω	0.3 V

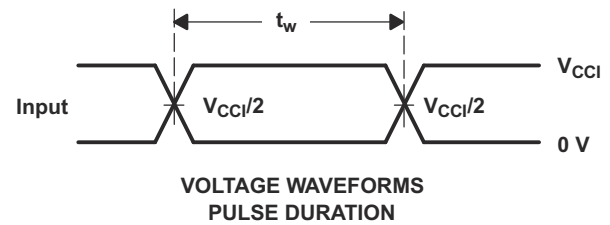

VOLTAGE WAVEFORMS PULSE DURATION

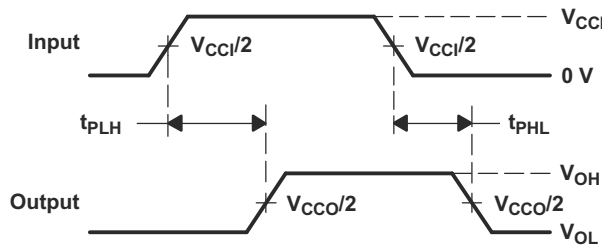

VOLTAGE WAVEFORMS PROPAGATION DELAY TIMES

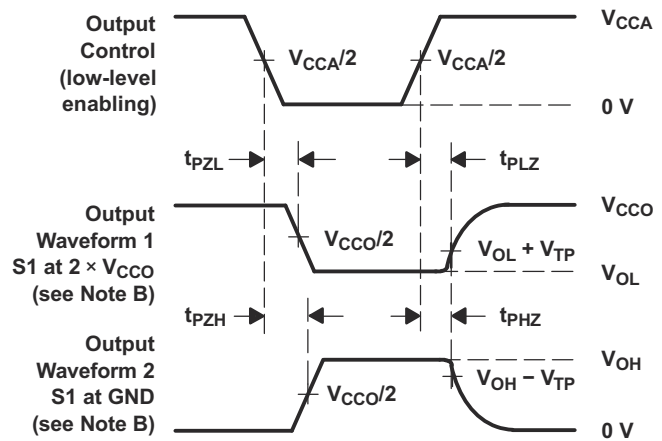

VOLTAGE WAVEFORMS ENABLE AND DISABLE TIMES

- NOTES:
- C_L includes probe and jig capacitance.
 - Waveform 1 is for an output with internal conditions such that the output is low except when disabled by the output control. Waveform 2 is for an output with internal conditions such that the output is high, except when disabled by the output control.
 - All input pulses are supplied by generators having the following characteristics: $PRR \leq 10$ MHz, $Z_O = 50 \Omega$, $dv/dt \geq 1$ V/ns.
 - The outputs are measured one at a time, with one transition per measurement.
 - t_{PLZ} and t_{PHZ} are the same as t_{dis} .
 - t_{PZL} and t_{PZH} are the same as t_{en} .
 - t_{PLH} and t_{PHL} are the same as t_{pd} .
 - V_{CC1} is the V_{CC} associated with the input port.
 - V_{CCO} is the V_{CC} associated with the output port.

图 6-1. Load Circuit and Voltage Waveforms

7 Detailed Description

7.1 Overview

The SN74AVC8T245-Q1 is an 8-bit, dual-supply noninverting bidirectional voltage level translation device. V_{CCA} supports the Ax pins and control pins (DIR and \overline{OE}), and V_{CCB} supports the Bx pins. The A port can accept I/O voltages ranging from 1.2 V to 3.6 V, while the B port can accept I/O voltages from 1.2 V to 3.6 V. A high on DIR allows data transmission from Ax to Bx and a low on DIR allows data transmission from Bx to Ax when \overline{OE} is set to low. When \overline{OE} is set to high, both Ax and Bx pins are in the high-impedance state.

7.2 Functional Block Diagram



图 7-1. Logic Diagram (Positive Logic)

7.3 Feature Description

7.3.1 Fully Configurable Dual-Rail Design

Both V_{CCA} and V_{CCB} can be supplied at any voltage between 1.2 V and 3.6 V; thus, making the device an excellent choice for translating between any of the low voltage nodes (1.2 V, 1.8 V, 2.5 V, and 3.3 V).

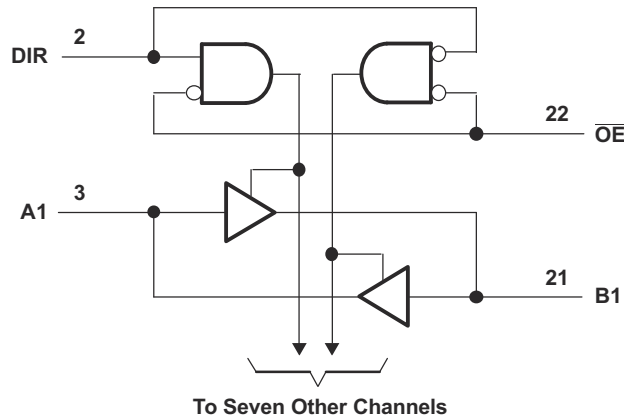
7.3.2 Supports High Speed Translation

The SN74AVC8T245-Q1 device can support high data rate applications. The translated signal data rate can be up to 380Mbps when the signal is translated from 1.8 V to 3.3 V.

7.3.3 I_{off} Supports Partial-Power-Down Mode Operation

I_{off} prevents backflow current by disabling I/O output circuits when the device is in partial-power-down mode.

7.4 Device Functional Modes

表 7-1 lists the functional modes of the device.

表 7-1. Function Table
(Each 8-Bit Section)

INPUTS		OPERATION
\overline{OE}	DIR	
L	L	B data to A bus
L	H	A data to B bus
H	X	All outputs Hi-Z

8 Application and Implementation

备注

以下应用部分中的信息不属于 TI 器件规格的范围，TI 不担保其准确性和完整性。TI 的客户应负责确定器件是否适用于其应用。客户应验证并测试其设计，以确保系统功能。

8.1 Application Information

The SN74AVC8T245-Q1 device can be used in level-translation applications for interfacing devices or systems operating at different interface voltages with one another. The SN74AVC8T245-Q1 device is an excellent choice for applications where a push-pull driver is connected to the data I/Os. The maximum data rate can be up to 320Mbps when the device translates a signal from 1.8 V to 3.3 V.

8.2 Typical Application



图 8-1. Typical Application Diagram

8.2.1 Design Requirements

表 8-1 lists the parameters for this design example.

表 8-1. Design Parameters

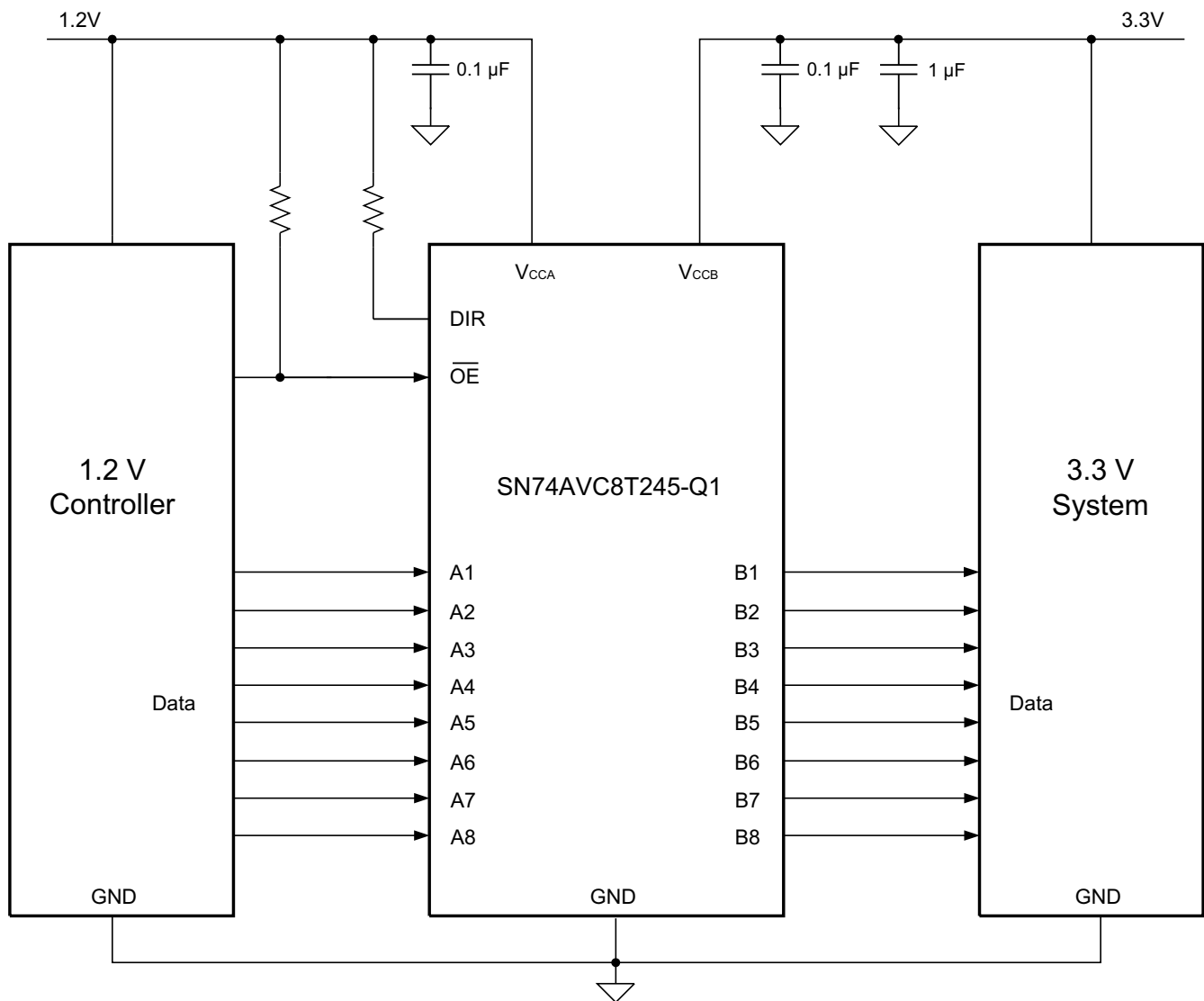
DESIGN PARAMETER	EXAMPLE VALUE
Input voltage range	1.2 V
Output voltage range	3.3 V

8.2.2 Detailed Design Procedure

To begin the design process, determine the following:

- Input voltage range
 - Use the supply voltage of the device that is driving the SN74AVC8T245-Q1 device to determine the input voltage range. For a valid logic high, the value must exceed the V_{IH} of the input port. For a valid logic low, the value must be less than the V_{IL} of the input port. For this example, the input voltage is 1.2 V.
- Output voltage range
 - Use the supply voltage of the device that the SN74AVC8T245-Q1 device is driving to determine the output voltage range. For this example, the output voltage is 3.3 V.

8.2.3 Application Curve



图 8-2. Translation Up (1.2 V to 3.3 V) at 2.5 MHz

8.3 Power Supply Recommendations

The SN74AVC8T245-Q1 device uses two separate configurable power-supply rails: V_{CCA} and V_{CCB} . V_{CCA} accepts any supply voltage from 1.2 V to 3.6 V, and V_{CCB} accepts any supply voltage from 1.2 V to 3.6 V. The A port and B port are designed to track V_{CCA} and V_{CCB} respectively, allowing for low-voltage bidirectional translation between any of the 1.2-V, 1.5-V, 1.8-V, 2.5-V, and 3.3-V voltage nodes.

V_{CCA} supplies the output-enable (\overline{OE}) input circuit in this design; when the \overline{OE} input is high, all outputs are placed in the high-impedance state. To put the outputs in the high-impedance state during power up or power down, the \overline{OE} input pin must be tied to V_{CCA} through a pullup resistor and must not be enabled until V_{CCA} and V_{CCB} are fully ramped and stable. The current-sinking capability of the driver determines the minimum value of the pullup resistor to V_{CCA} .

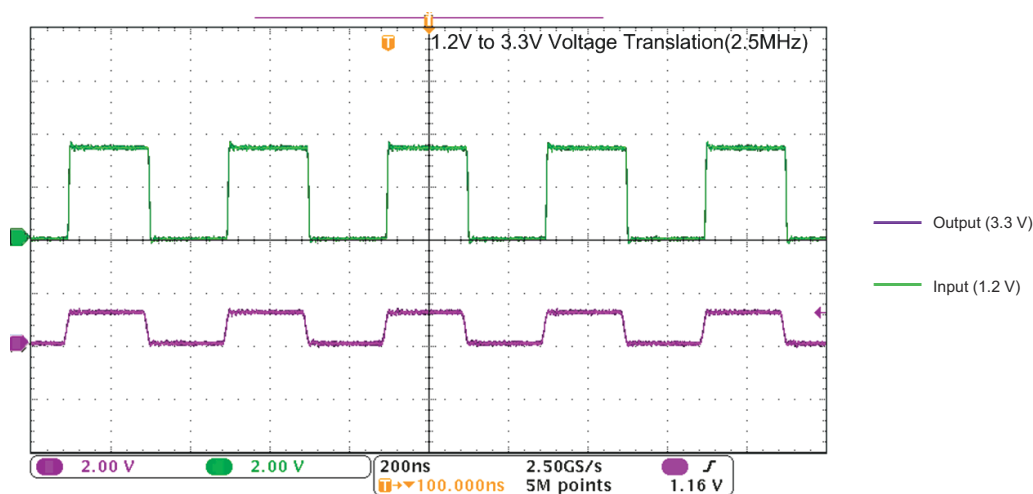
8.4 Layout

8.4.1 Layout Guidelines

For device reliability, it is recommended to follow common printed-circuit board layout guidelines:

- Use bypass capacitors on power supplies.
- Use short trace lengths to avoid excessive loading.
- Place pads on the signal paths for loading capacitors or pullup resistors to adjust signal rise and fall times, depending on the system requirements.

8.4.2 Layout Example

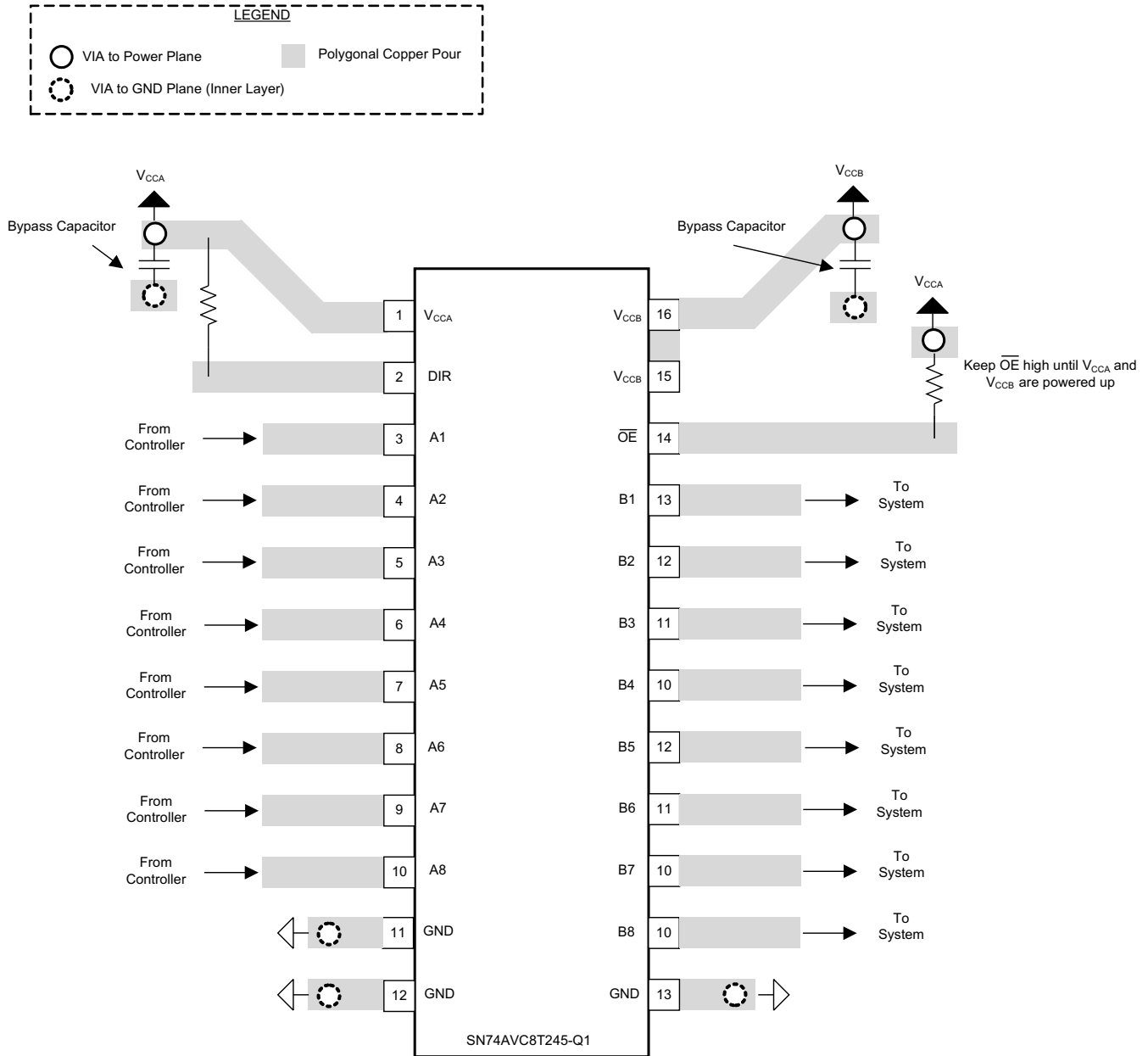

9 Device and Documentation Support

9.1 Documentation Support

9.1.1 Related Documentation

For related documentation see the following:

- Texas Instruments, [Implications of Slow or Floating CMOS Inputs Application Note](#)
- Texas Instruments, [Understanding and Interpreting Standard-Logic Data Sheets Application Note](#)
- Texas Instruments, [Introduction to Logic Application Note](#)
- Texas Instruments, [Voltage Translation Between 3.3-V, 2.5-V, 1.8-V, and 1.5-V Logic Standards Application Note](#)
- Texas Instruments, [AVC Advanced Very-Low-Voltage CMOS Logic Data Book User's Guide](#)

9.2 接收文档更新通知

要接收文档更新通知，请导航至 ti.com 上的器件产品文件夹。点击 [通知](#) 进行注册，即可每周接收产品信息更改摘要。有关更改的详细信息，请查看任何已修订文档中包含的修订历史记录。

9.3 支持资源

[TI E2E™ 中文支持论坛](#) 是工程师的重要参考资料，可直接从专家处获得快速、经过验证的解答和设计帮助。搜索现有解答或提出自己的问题，获得所需的快速设计帮助。

链接的内容由各个贡献者“按原样”提供。这些内容并不构成 TI 技术规范，并且不一定反映 TI 的观点；请参阅 TI 的 [使用条款](#)。

9.4 Trademarks

TI E2E™ is a trademark of Texas Instruments.

所有商标均为其各自所有者的财产。

9.5 静电放电警告



静电放电 (ESD) 会损坏这个集成电路。德州仪器 (TI) 建议通过适当的预防措施处理所有集成电路。如果不遵守正确的处理和安装程序，可能会损坏集成电路。

ESD 的损坏小至导致微小的性能降级，大至整个器件故障。精密的集成电路可能更容易受到损坏，这是因为非常细微的参数更改都可能会导致器件与其发布的规格不相符。

9.6 术语表

[TI 术语表](#) 本术语表列出并解释了术语、首字母缩略词和定义。

10 Revision History

注：以前版本的页码可能与当前版本的页码不同

Changes from Revision D (October 2017) to Revision E (November 2023)	Page
• 更新了整个文档中的表格、图和交叉参考的编号格式.....	1
• Updated the thermal information for the <i>RHL</i> package and updated the information for the <i>PW</i> package.....	6
Changes from Revision C (March 2016) to Revision D (October 2017)	Page
• Added Junction temperature, T_j in <i>Absolute Maximum Ratings</i> table.....	4
• Deleted 2DIR and 2 \overline{OE} from <i>Overview</i>	17
Changes from Revision B (December 2012) to Revision C (January 2016)	Page
• 添加了 <i>ESD</i> 等级表、特性说明部分、器件功能模式、应用和实施部分、电源相关建议部分、布局部分、器件和文档支持部分以及机械、封装和可订购信息部分.....	1
• 删除了 <i>订购信息</i> 表.....	1

Changes from Revision A (June 2011) to Revision B (December 2012)	Page
• 向“特性”列表添加了要点.....	1
• Added <i>Pin Functions</i> table to the data sheet.....	3
• Deleted θ_{JA} row from <i>Absolute Maximum Ratings</i> table.....	4
• Changed ESD ratings.....	4
• Added Thermal Information table.....	6
• Added Figure 7-10 and Figure 7-11 to the <i>Typical Characteristics</i> section	14

11 Mechanical, Packaging, and Orderable Information

The following pages include mechanical, packaging, and orderable information. This information is the most current data available for the designated devices. This data is subject to change without notice and revision of this document. For browser-based versions of this data sheet, refer to the left-hand navigation.

PACKAGING INFORMATION

Orderable Device	Status (1)	Package Type	Package Drawing	Pins	Package Qty	Eco Plan (2)	Lead finish/ Ball material (6)	MSL Peak Temp (3)	Op Temp (°C)	Device Marking (4/5)	Samples
CAVC8T245QRHLRQ1	ACTIVE	VQFN	RHL	24	1000	RoHS & Green	NIPDAU	Level-2-260C-1 YEAR	-40 to 125	WE245Q	Samples
SN74AVC8T245QPWRQ1	ACTIVE	TSSOP	PW	24	2000	RoHS & Green	NIPDAU	Level-3-260C-168 HR	-40 to 125	WE245Q	Samples

(1) The marketing status values are defined as follows:

ACTIVE: Product device recommended for new designs.

LIFEBUY: TI has announced that the device will be discontinued, and a lifetime-buy period is in effect.

NRND: Not recommended for new designs. Device is in production to support existing customers, but TI does not recommend using this part in a new design.

PREVIEW: Device has been announced but is not in production. Samples may or may not be available.

OBSOLETE: TI has discontinued the production of the device.

(2) **RoHS:** TI defines "RoHS" to mean semiconductor products that are compliant with the current EU RoHS requirements for all 10 RoHS substances, including the requirement that RoHS substance do not exceed 0.1% by weight in homogeneous materials. Where designed to be soldered at high temperatures, "RoHS" products are suitable for use in specified lead-free processes. TI may reference these types of products as "Pb-Free".

RoHS Exempt: TI defines "RoHS Exempt" to mean products that contain lead but are compliant with EU RoHS pursuant to a specific EU RoHS exemption.

Green: TI defines "Green" to mean the content of Chlorine (Cl) and Bromine (Br) based flame retardants meet JS709B low halogen requirements of <=1000ppm threshold. Antimony trioxide based flame retardants must also meet the <=1000ppm threshold requirement.

(3) MSL, Peak Temp. - The Moisture Sensitivity Level rating according to the JEDEC industry standard classifications, and peak solder temperature.

(4) There may be additional marking, which relates to the logo, the lot trace code information, or the environmental category on the device.

(5) Multiple Device Markings will be inside parentheses. Only one Device Marking contained in parentheses and separated by a "~" will appear on a device. If a line is indented then it is a continuation of the previous line and the two combined represent the entire Device Marking for that device.

(6) Lead finish/Ball material - Orderable Devices may have multiple material finish options. Finish options are separated by a vertical ruled line. Lead finish/Ball material values may wrap to two lines if the finish value exceeds the maximum column width.

Important Information and Disclaimer:The information provided on this page represents TI's knowledge and belief as of the date that it is provided. TI bases its knowledge and belief on information provided by third parties, and makes no representation or warranty as to the accuracy of such information. Efforts are underway to better integrate information from third parties. TI has taken and continues to take reasonable steps to provide representative and accurate information but may not have conducted destructive testing or chemical analysis on incoming materials and chemicals. TI and TI suppliers consider certain information to be proprietary, and thus CAS numbers and other limited information may not be available for release.

In no event shall TI's liability arising out of such information exceed the total purchase price of the TI part(s) at issue in this document sold by TI to Customer on an annual basis.

OTHER QUALIFIED VERSIONS OF SN74AVC8T245-Q1 :

- Catalog : [SN74AVC8T245](#)

NOTE: Qualified Version Definitions:

- Catalog - TI's standard catalog product

TAPE AND REEL INFORMATION

QUADRANT ASSIGNMENTS FOR PIN 1 ORIENTATION IN TAPE

*All dimensions are nominal

Device	Package Type	Package Drawing	Pins	SPQ	Reel Diameter (mm)	Reel Width W1 (mm)	A0 (mm)	B0 (mm)	K0 (mm)	P1 (mm)	W (mm)	Pin1 Quadrant
CAVC8T245QRHLRQ1	VQFN	RHL	24	1000	180.0	12.4	3.8	5.8	1.2	8.0	12.0	Q1
SN74AVC8T245QPWRQ1	TSSOP	PW	24	2000	330.0	16.4	6.95	8.3	1.6	8.0	16.0	Q1

TAPE AND REEL BOX DIMENSIONS

*All dimensions are nominal

Device	Package Type	Package Drawing	Pins	SPQ	Length (mm)	Width (mm)	Height (mm)
CAVC8T245QRHLRQ1	VQFN	RHL	24	1000	210.0	185.0	35.0
SN74AVC8T245QPWRQ1	TSSOP	PW	24	2000	356.0	356.0	35.0

PW0024A



PACKAGE OUTLINE

TSSOP - 1.2 mm max height

SMALL OUTLINE PACKAGE



4220208/A 02/2017

NOTES:

1. All linear dimensions are in millimeters. Any dimensions in parenthesis are for reference only. Dimensioning and tolerancing per ASME Y14.5M.
2. This drawing is subject to change without notice.
3. This dimension does not include mold flash, protrusions, or gate burrs. Mold flash, protrusions, or gate burrs shall not exceed 0.15 mm per side.
4. This dimension does not include interlead flash. Interlead flash shall not exceed 0.25 mm per side.
5. Reference JEDEC registration MO-153.

EXAMPLE BOARD LAYOUT

PW0024A

TSSOP - 1.2 mm max height

SMALL OUTLINE PACKAGE



LAND PATTERN EXAMPLE
EXPOSED METAL SHOWN
SCALE: 10X



SOLDER MASK DETAILS

4220208/A 02/2017

NOTES: (continued)

- 6. Publication IPC-7351 may have alternate designs.
- 7. Solder mask tolerances between and around signal pads can vary based on board fabrication site.

EXAMPLE STENCIL DESIGN

PW0024A

TSSOP - 1.2 mm max height

SMALL OUTLINE PACKAGE



NOTES: (continued)

8. Laser cutting apertures with trapezoidal walls and rounded corners may offer better paste release. IPC-7525 may have alternate design recommendations.
9. Board assembly site may have different recommendations for stencil design.

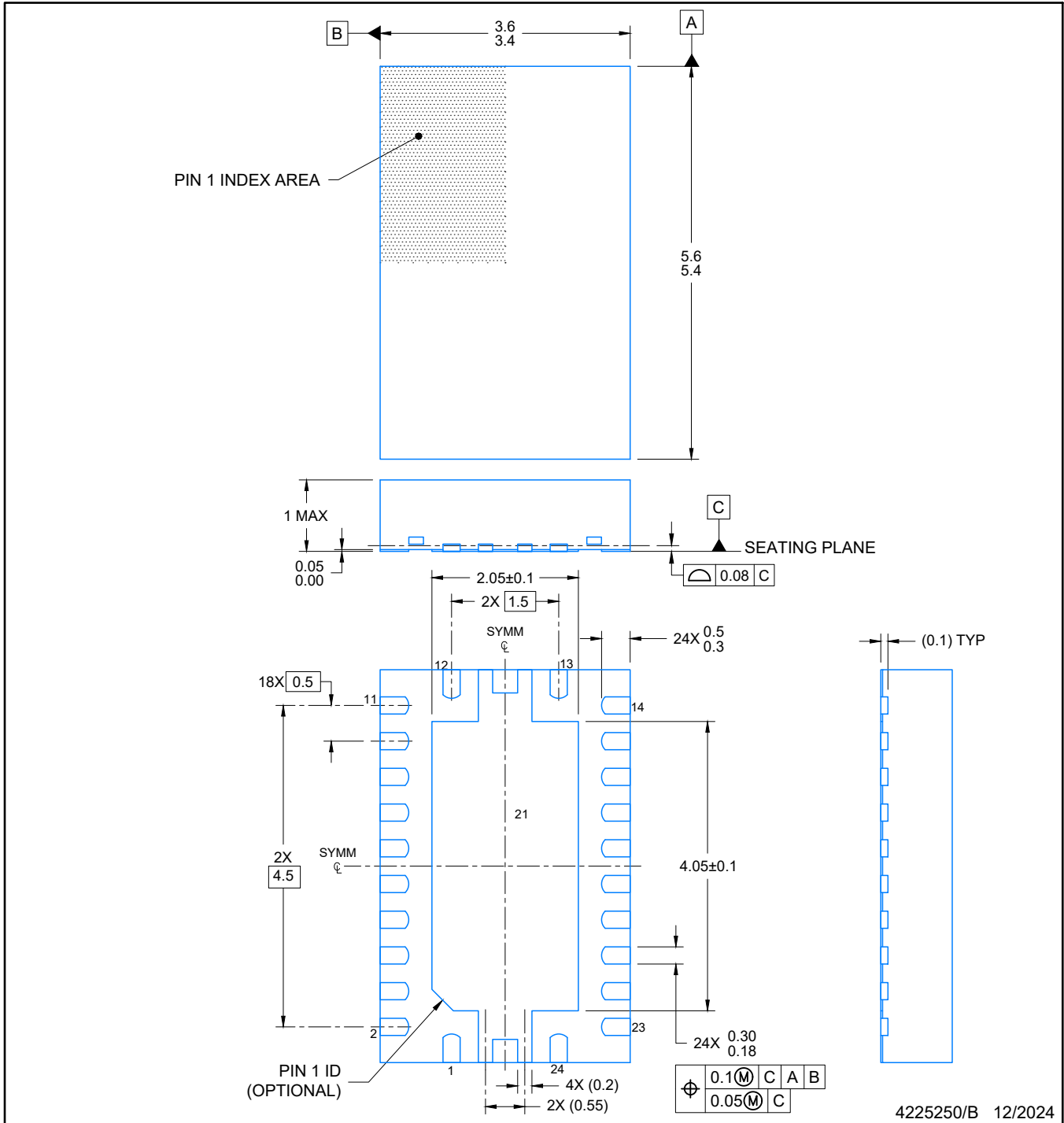

NOTES:

1. All linear dimensions are in millimeters. Any dimensions in parenthesis are for reference only. Dimensioning and tolerancing per ASME Y14.5M.
2. This drawing is subject to change without notice.
3. The package thermal pad must be soldered to the printed circuit board for optimal thermal and mechanical performance.

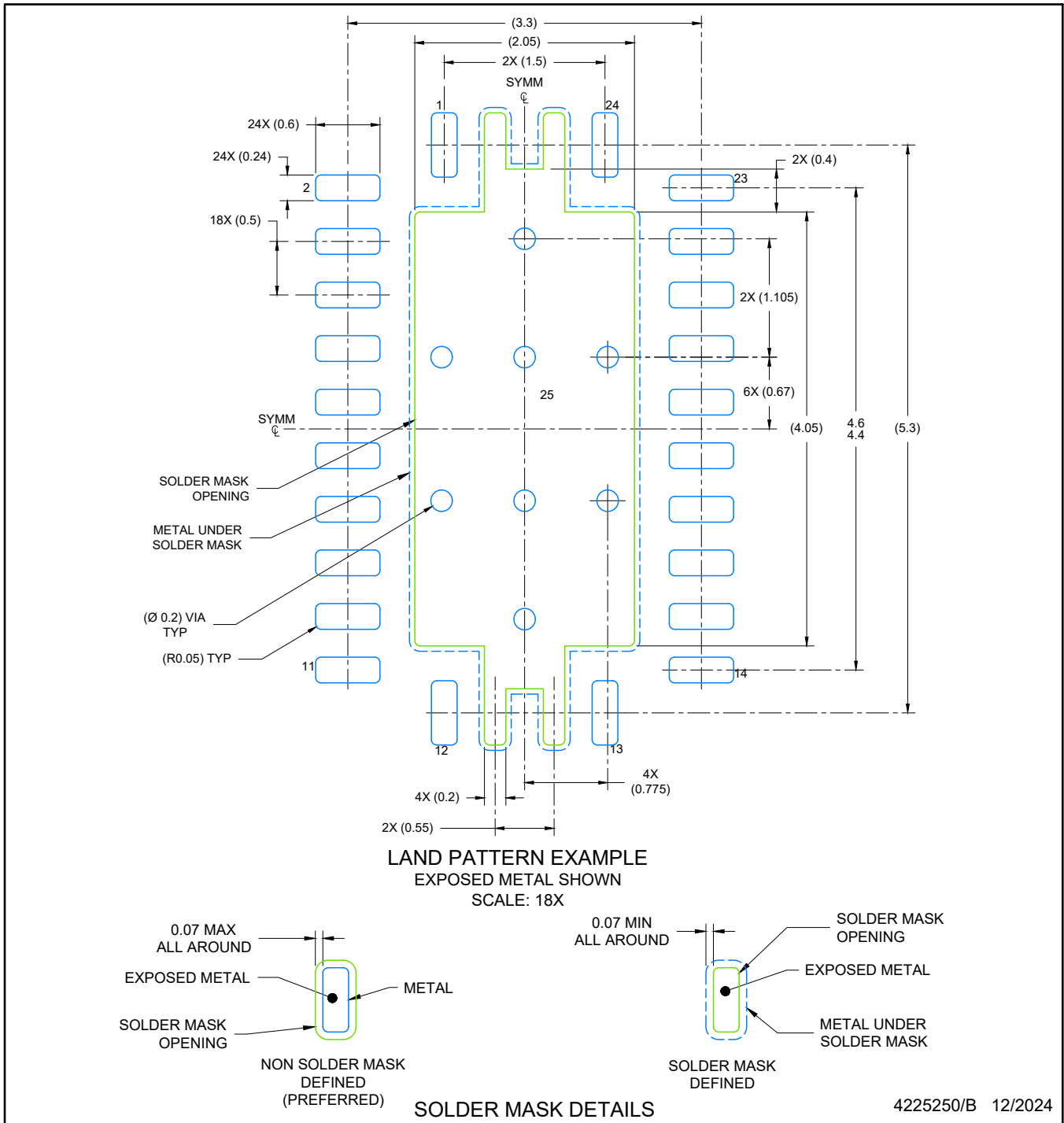

NOTES: (continued)

4. This package is designed to be soldered to a thermal pad on the board. For more information, see Texas Instruments literature number SLUA271 (www.ti.com/lit/sluea271).
5. Vias are optional depending on application, refer to device data sheet. If any vias are implemented, refer to their locations shown on this view. It is recommended that vias under paste be filled, plugged or tented.

EXAMPLE STENCIL DESIGN

VQFN - 1 mm max height

RHL0024A

PLASTIC QUAD FLATPACK- NO LEAD

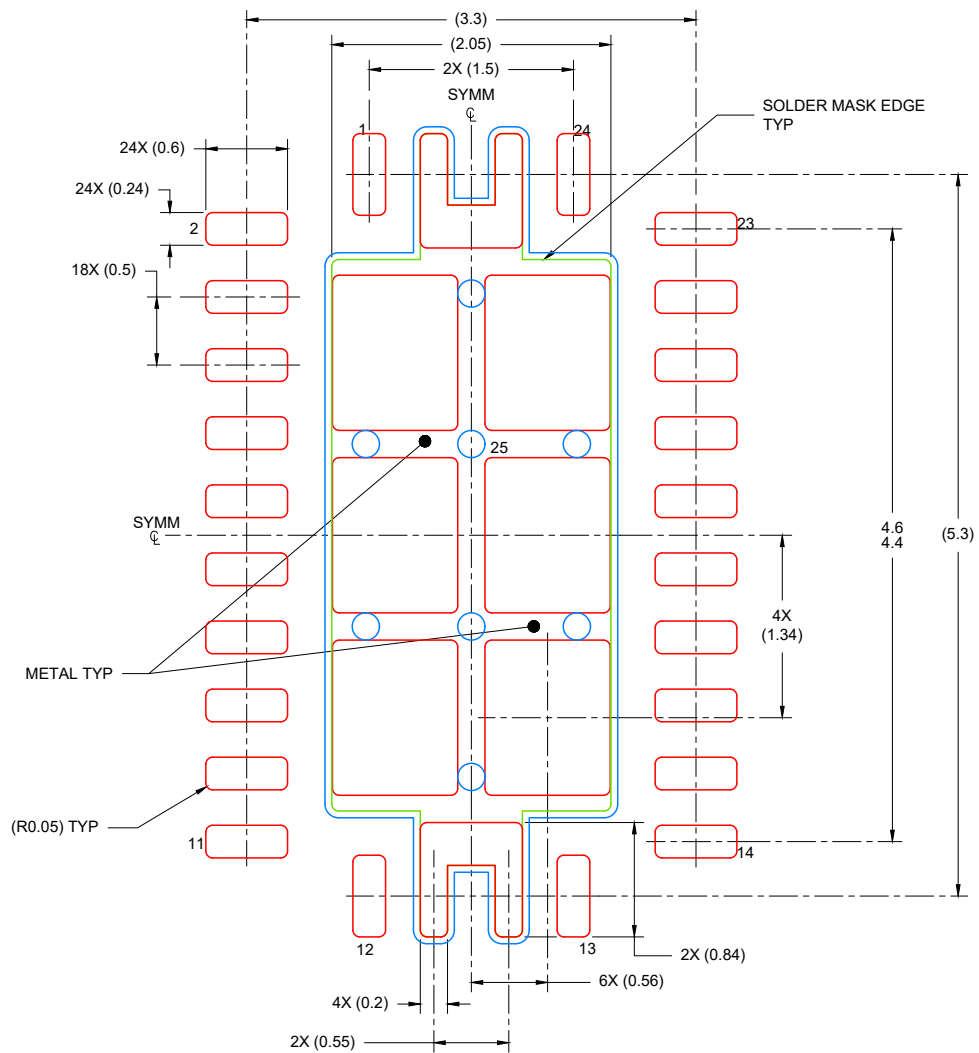

SOLDER PASTE EXAMPLE
BASED ON 0.125 mm THICK STENCIL

EXPOSED PAD
80% PRINTED COVERAGE BY AREA
SCALE: 18X

4225250/B 12/2024

NOTES: (continued)

6. Laser cutting apertures with trapezoidal walls and rounded corners may offer better paste release. IPC-7525 may have alternate design recommendations.

重要通知和免责声明

TI“按原样”提供技术和可靠性数据（包括数据表）、设计资源（包括参考设计）、应用或其他设计建议、网络工具、安全信息和其他资源，不保证没有瑕疵且不做任何明示或暗示的担保，包括但不限于对适销性、某特定用途方面的适用性或不侵犯任何第三方知识产权的暗示担保。

这些资源可供使用 TI 产品进行设计的熟练开发人员使用。您将自行承担以下全部责任：(1) 针对您的应用选择合适的 TI 产品，(2) 设计、验证并测试您的应用，(3) 确保您的应用满足相应标准以及任何其他功能安全、信息安全、监管或其他要求。

这些资源如有变更，恕不另行通知。TI 授权您仅可将这些资源用于研发本资源所述的 TI 产品的相关应用。严禁以其他方式对这些资源进行复制或展示。您无权使用任何其他 TI 知识产权或任何第三方知识产权。您应全额赔偿因在这些资源的使用中对 TI 及其代表造成的任何索赔、损害、成本、损失和债务，TI 对此概不负责。

TI 提供的产品受 [TI 的销售条款](#) 或 [ti.com](#) 上其他适用条款/TI 产品随附的其他适用条款的约束。TI 提供这些资源并不会扩展或以其他方式更改 TI 针对 TI 产品发布的适用的担保或担保免责声明。

TI 反对并拒绝您可能提出的任何其他或不同的条款。

邮寄地址：Texas Instruments, Post Office Box 655303, Dallas, Texas 75265
版权所有 © 2025，德州仪器 (TI) 公司