

## SN74AVCH8T245 具有可配置电平转换、电压转换和三态输出的 8 位双电源总线收发器

### 1 特性

- 控制输入 ( DIR 和  $\overline{OE}$  )  $V_{IH}$  和  $V_{IL}$  电平以  $V_{CCA}$  电压为基准
- 总线保持数据输入消除了对外部上拉或下拉电阻器的需求
- $V_{CC}$  隔离特性
- 完全可配置的双轨设计
- I/O 可承受 4.6V 的电压
- $I_{off}$  支持局部关断模式运行
- 最大数据速率：
  - 320Mbps (  $V_{CCA} \geq 1.8V$  和  $V_{CCB} \geq 1.8V$  )
  - 170Mbps (  $V_{CCA} \leq 1.8V$  或  $V_{CCB} \leq 1.8V$  )
- 闩锁性能超过 100mA，符合 JESD 78 II 类规范
- ESD 保护性能超过 JESD 22 规范要求：
  - 8000V 人体放电模型 (A114-A)
  - 200V 机器放电模型 (A115-A)
  - 1000V 充电器件模型 (C101)

### 2 应用

- 个人电子产品
- 工业
- 企业
- 电信

### 3 说明

SN74AVCH8T245 是一款采用两个独立可配置电源轨的 8 位同相总线收发器。A 端口用于跟踪  $V_{CCA}$ ，该端口也可支持 1.2V 至 3.6V 范围内的任何电源电压。B 端口用于跟踪  $V_{CCB}$ ，该端口也可支持 1.2V 至 3.6V 范围内的任何电源电压。这样可实现 1.2V、1.5V、1.8V、2.5V 和 3.3V 电压节点之间进行通用低压双向转换。

SN74AVCH8T245 旨在实现数据总线间的异步通信。根据方向控制 (DIR) 输入上的逻辑电平，此器件将数据从 A 总线发送至 B 总线，或者将数据从 B 总线发送至 A 总线。输出使能 (OE) 可被用来禁用输出，这样可有效隔离总线。

SN74AVCH8T245 控制引脚 ( DIR 和  $\overline{OE}$  ) 的设计以  $V_{CCA}$  为基准。

有源总线保持电路会将未使用或未驱动的输出保持在有效逻辑状态。不建议在总线保持电路上使用上拉或下拉电阻。

该器件完全符合使用  $I_{off}$  的部分断电应用的规范要求。 $I_{off}$  电路禁用输出，从而可防止破坏性电流从该器件回流。

$V_{CC}$  隔离特性可确保  $V_{CCA}$  或  $V_{CCB}$  接地 (GND) 时，输出都处于高阻抗状态。上电侧的总线保持电路始终保持有效状态。

此 SN74AVCH8T245 解决方案与单电源系统兼容，并且后续可以替换为具备 '245 的功能，只需较小程度的印刷电路板重新设计。

要在上电或断电期间将器件置于高阻抗状态，必须通过一个上拉电阻器将  $\overline{OE}$  连接至  $V_{CCA}$ ；该电阻器的最小值由驱动器的电流灌入能力决定。

#### 封装信息

| 器件型号          | 封装 <sup>(1)</sup>  | 封装尺寸 <sup>(2)</sup> |
|---------------|--------------------|---------------------|
| SN74AVCH8T245 | DGV ( TVSOP , 24 ) | 5mm × 6.4mm         |
|               | PW ( TSSOP , 24 )  | 7.8mm × 6.4mm       |
|               | RHL ( VQFN , 24 )  | 5.5mm × 3.5mm       |

(1) 有关更多信息，请参阅节 11。

(2) 封装尺寸 (长 × 宽) 为标称值，并包括引脚 (如适用)。

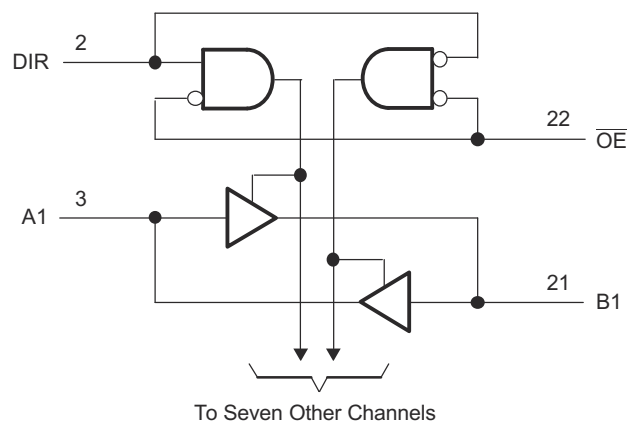

逻辑图 (正逻辑)



## Table of Contents

|   |    |  |    |
|---|----|--|----|
| <b>1 特性</b> .....   | 1  | 7.1 Overview.....  | 17 |
| <b>2 应用</b> .....   | 1  | 7.2 Functional Block Diagram.....                                | 17 |
| <b>3 说明</b> .....   | 1  | 7.3 Feature Description.....                                     | 17 |
| <b>4 Pin Configuration and Functions</b> .....                  | 3  | 7.4 Device Functional Modes.....                                 | 18 |
| <b>5 Specifications</b> .....                                   | 4  | <b>8 Application and Implementation</b> .....                    | 19 |
| 5.1 Absolute Maximum Ratings.....                               | 4  | 8.1 Application Information.....                                 | 19 |
| 5.2 ESD Ratings.....  | 4  | 8.2 Typical Application.....                                     | 19 |
| 5.3 Recommended Operating Conditions.....                       | 5  | 8.3 Power Supply Recommendations.....                            | 20 |
| 5.4 Thermal Information.....                                    | 6  | 8.4 Layout.....  | 21 |
| 5.5 Electrical Characteristics.....                             | 6  | <b>9 Device and Documentation Support</b> .....                  | 22 |
| 5.6 Switching Characteristics, $V_{CCA} = 1.2V$ .....           | 8  | 9.1 Documentation Support.....                                   | 22 |
| 5.7 Switching Characteristics, $V_{CCA} = 1.5V \pm 0.1V$ .....  | 9  | 9.2 接收文档更新通知.....  | 22 |
| 5.8 Switching Characteristics, $V_{CCA} = 1.8V \pm 0.15V$ ..... | 10 | 9.3 支持资源.....  | 22 |
| 5.9 Switching Characteristics, $V_{CCA} = 2.5V \pm 0.2V$ .....  | 11 | 9.4 Trademarks.....  | 22 |
| 5.10 Switching Characteristics, $V_{CCA} = 3.3V \pm 0.3V$ ..... | 12 | 9.5 静电放电警告.....  | 22 |
| 5.11 Operating Characteristics.....                             | 13 | 9.6 术语表.....   | 22 |
| 5.12 Typical Characteristics.....                               | 14 | <b>10 Revision History</b> .....                                 | 22 |
| <b>6 Parameter Measurement Information</b> .....                | 16 | <b>11 Mechanical, Packaging, and Orderable Information</b> ..... | 23 |
| <b>7 Detailed Description</b> .....                             | 17 |  |    |

## 4 Pin Configuration and Functions



图 4-1. DGV or PW Package, 24-Pin TVSOP or TSSOP (Top View)



图 4-2. RHL Package, 24-Pin VQFN (Top View)

表 4-1. Pin Functions

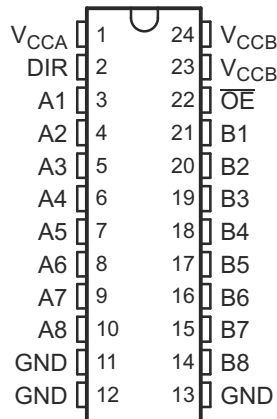
| PIN             |            | I/O | DESCRIPTION  |
|-----------------|------------|-----|--|
| NAME            | NO.        |     |  |
| A1              | 3          | I/O | Input/output A1. Referenced to $V_{CCA}$ .   |
| A2              | 4          | I/O | Input/output A2. Referenced to $V_{CCA}$ .   |
| A3              | 5          | I/O | Input/output A3. Referenced to $V_{CCA}$ .   |
| A4              | 6          | I/O | Input/output A4. Referenced to $V_{CCA}$ .   |
| A5              | 7          | I/O | Input/output A5. Referenced to $V_{CCA}$ .   |
| A6              | 8          | I/O | Input/output A6. Referenced to $V_{CCA}$ .   |
| A7              | 9          | I/O | Input/output A7. Referenced to $V_{CCA}$ .   |
| A8              | 10         | I/O | Input/output A8. Referenced to $V_{CCA}$ .   |
| B1              | 21         | I/O | Input/output B1. Referenced to $V_{CCB}$ .   |
| B2              | 20         | I/O | Input/output B2. Referenced to $V_{CCB}$ .   |
| B3              | 19         | I/O | Input/output B3. Referenced to $V_{CCB}$ .   |
| B4              | 18         | I/O | Input/output B4. Referenced to $V_{CCB}$ .   |
| B5              | 17         | I/O | Input/output B5. Referenced to $V_{CCB}$ .   |
| B6              | 16         | I/O | Input/output B6. Referenced to $V_{CCB}$ .   |
| B7              | 15         | I/O | Input/output B7. Referenced to $V_{CCB}$ .   |
| B8              | 14         | I/O | Input/output B8. Referenced to $V_{CCB}$ .   |
| DIR             | 2          | I   | Direction-control signal. Referenced to $V_{CCA}$ .  |
| GND             | 11, 12, 13 | —   | Ground   |
| $\overline{OE}$ | 22         | I   | 3-state output-mode enables. Pull $\overline{OE}$ high to place all outputs in 3-state mode. Referenced to $V_{CCA}$ . |
| $V_{CCA}$       | 1          | —   | A-port supply voltage. $1.2V \leq V_{CCA} \leq 3.6V$   |
| $V_{CCB}$       | 23, 24     | —   | B-port supply voltage. $1.2V \leq V_{CCA} \leq 3.6V$   |

## 5 Specifications

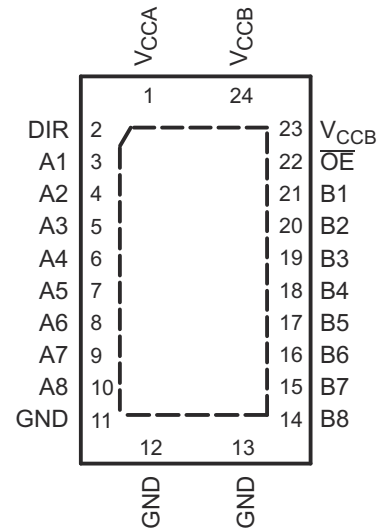
### 5.1 Absolute Maximum Ratings

over operating free-air temperature range (unless otherwise noted)<sup>(1)</sup>

|                  |   |                    | MIN  | MAX                    | UNIT |
|------------------|---|--------------------|------|------------------------|------|
| V <sub>CCA</sub> | Supply voltage  |                    | -0.5 | 4.6                    | V    |
| V <sub>CCB</sub> |   |                    |      |                        |      |
| V <sub>I</sub>   | Input voltage <sup>(2)</sup>  | I/O ports (A port) | -0.5 | 4.6                    | V    |
|                  |   | I/O ports (B port) | -0.5 | 4.6                    |      |
|                  |   | Control inputs     | -0.5 | 4.6                    |      |
| V <sub>O</sub>   | Voltage applied to any output in the high-impedance or power-off state <sup>(2)</sup> | A port             | -0.5 | 4.6                    | V    |
|                  |   | B port             | -0.5 | 4.6                    |      |
| V <sub>O</sub>   | Voltage applied to any output in the high or low state <sup>(2) (3)</sup>             | A port             | -0.5 | V <sub>CCA</sub> + 0.5 | V    |
|                  |   | B port             | -0.5 | V <sub>CCB</sub> + 0.5 |      |
| I <sub>IK</sub>  | Input clamp current   | V <sub>I</sub> < 0 |      | -50                    | mA   |
| I <sub>OK</sub>  | Output clamp current  | V <sub>O</sub> < 0 |      | -50                    | mA   |
| I <sub>O</sub>   | Continuous output current   |                    |      | ±50                    | mA   |
|                  | Continuous current through V <sub>CCA</sub> , V <sub>CCB</sub> , or GND               |                    |      | ±100                   | mA   |
| T <sub>J</sub>   | Junction temperature  |                    | -40  | 150                    | °C   |
| T <sub>stg</sub> | Storage temperature   |                    | -65  | 150                    | °C   |

- (1) Stresses beyond those listed under *Absolute Maximum Ratings* may cause permanent damage to the device. These are stress ratings only, which do not imply functional operation of the device at these or any other conditions beyond those indicated under *Recommended Operating Conditions*. Exposure to absolute-maximum-rated conditions for extended periods may affect device reliability.
- (2) The input voltage and output negative-voltage ratings may be exceeded if the input and output current ratings are observed.
- (3) The output positive-voltage rating may be exceeded up to 4.6V maximum if the output current rating is observed.
- (4) The package thermal impedance is calculated in accordance with JESD 51-7.

### 5.2 ESD Ratings

|                    |                         |  | VALUE | UNIT |
|--------------------|-------------------------|--|-------|------|
| V <sub>(ESD)</sub> | Electrostatic discharge | Human-body model (HBM), per ANSI/ESDA/JEDEC JS-001 <sup>(1)</sup>              | ±8000 | V    |
|                    |                         | Charged-device model (CDM), per JEDEC specification JESD22-C101 <sup>(2)</sup> | ±1000 |      |
|                    |                         | Machine model (MM)   | ±200  |      |

- (1) JEDEC document JEP155 states that 500-V HBM allows safe manufacturing with a standard ESD control process.
- (2) JEDEC document JEP157 states that 250-V CDM allows safe manufacturing with a standard ESD control process.

### 5.3 Recommended Operating Conditions

See (1) (2)

|                       |   |  |                                   | MIN                     | MAX              | UNIT |
|-----------------------|---|--|-----------------------------------|-------------------------|------------------|------|
| V <sub>CCA</sub>      | Supply voltage                          |  |                                   | 1.2                     | 3.6              | V    |
| V <sub>CCB</sub>      | Supply voltage                          |  |                                   | 1.2                     | 3.6              | V    |
| V <sub>IH</sub>       | High-level input voltage <sup>(1)</sup> | Data inputs  | V <sub>CCI</sub> = 1.2V to 1.95V  | V <sub>CCI</sub> × 0.65 |                  | V    |
|                       |   |  | V <sub>CCI</sub> = 1.95V to 2.7V  | 1.6                     |                  |      |
|                       |   |  | V <sub>CCI</sub> = 2.7V to 3.6V   | 2                       |                  |      |
| V <sub>IL</sub>       | Low-level input voltage <sup>(1)</sup>  | Data inputs  | V <sub>CCI</sub> = 1.2V to 1.95V  | V <sub>CCI</sub> × 0.35 |                  | V    |
|                       |   |  | V <sub>CCI</sub> = 1.95V to 2.7V  | 0.7                     |                  |      |
|                       |   |  | V <sub>CCI</sub> = 2.7V to 3.6V   | 0.8                     |                  |      |
| V <sub>IH</sub>       | High-level input voltage                | DIR and $\overline{OE}$<br>(referenced to V <sub>CCA</sub> ) | V <sub>CCI</sub> = 1.2V to 1.95V  | V <sub>CCA</sub> × 0.65 |                  | V    |
|                       |   |  | V <sub>CCI</sub> = 1.95V to 2.7V  | 1.6                     |                  |      |
|                       |   |  | V <sub>CCI</sub> = 2.7V to 3.6V   | 2                       |                  |      |
| V <sub>IL</sub>       | Low-level input voltage                 | DIR and $\overline{OE}$<br>(referenced to V <sub>CCA</sub> ) | V <sub>CCI</sub> = 1.2V to 1.95V  | V <sub>CCA</sub> × 0.35 |                  | V    |
|                       |   |  | V <sub>CCI</sub> = 1.95V to 2.7V  | 0.7                     |                  |      |
|                       |   |  | V <sub>CCI</sub> = 2.7V to 3.6V   | 0.8                     |                  |      |
| V <sub>I</sub>        | Input voltage                           | Control Inputs   |                                   | 0                       | 3.6              | V    |
| V <sub>O</sub>        | Output voltage <sup>(2)</sup>           | Active state   |                                   | 0                       | V <sub>CCO</sub> | V    |
|                       |   | 3-state  |                                   | 0                       | 3.6              | V    |
| I <sub>OH</sub>       | High-level output current               |  | V <sub>CCO</sub> = 1.2V           | -3                      |                  | mA   |
|                       |   |  | V <sub>CCO</sub> = 1.4V to 1.6V   | -6                      |                  |      |
|                       |   |  | V <sub>CCO</sub> = 1.65V to 1.95V | -8                      |                  |      |
|                       |   |  | V <sub>CCO</sub> = 2.3V to 2.7V   | -9                      |                  |      |
|                       |   |  | V <sub>CCO</sub> = 3V to 3.6V     | -12                     |                  |      |
| I <sub>OL</sub>       | Low-level output current                |  | V <sub>CCO</sub> = 1.2V           | 3                       |                  | mA   |
|                       |   |  | V <sub>CCO</sub> = 1.4V to 1.6V   | 6                       |                  |      |
|                       |   |  | V <sub>CCO</sub> = 1.65V to 1.95V | 8                       |                  |      |
|                       |   |  | V <sub>CCO</sub> = 2.3V to 2.7V   | 9                       |                  |      |
|                       |   |  | V <sub>CCO</sub> = 3V to 3.6V     | 12                      |                  |      |
| $\Delta t / \Delta v$ | Input transition rise or fall rate      |  |                                   |                         | 5                | ns/V |
| T <sub>A</sub>        | Operating free-air temperature          |  |                                   | -40                     | 85               | °C   |

 (1) V<sub>CCI</sub> is the V<sub>CC</sub> associated with the input port.

 (2) V<sub>CCO</sub> is the V<sub>CC</sub> associated with the output port.

## 5.4 Thermal Information

| THERMAL METRIC <sup>(1)</sup> |   | SN74AVCH8T245 |            |            | UNIT |
|-------------------------------|---|---------------|------------|------------|------|
|                               |   | DGV (TVSOP)   | PW (TSSOP) | RHL (VQFN) |      |
|                               |   | 24 PINS       | 24 PINS    | 24 PINS    |      |
| $R_{\theta JA}$               | Junction-to-ambient thermal resistance <sup>(4)</sup> | 116.7         | 93.1       | 36.8       | °C/W |
| $R_{\theta JC(top)}$          | Junction-to-case (top) thermal resistance             | 48.5          | 36.7       | 32.5       | °C/W |
| $R_{\theta JB}$               | Junction-to-board thermal resistance                  | 62.1          | 48.4       | 15.7       | °C/W |
| $\psi_{JT}$                   | Junction-to-top characterization parameter            | 7.0           | 93.1       | 0.7        | °C/W |
| $\psi_{JB}$                   | Junction-to-board characterization parameter          | 61.6          | 48.0       | 15.6       | °C/W |
| $R_{\theta JC(bot)}$          | Junction-to-case (bottom) thermal resistance          | N/A           | N/A        | 5.6        | °C/W |

(1) For more information about traditional and new thermal metrics, see the *Semiconductor and IC Package Thermal Metrics* application report, [SPRA953](#).

## 5.5 Electrical Characteristics

All typical limits apply over  $T_A = 25^\circ\text{C}$ , and all maximum and minimum limits apply over  $T_A = -40^\circ\text{C}$  to  $85^\circ\text{C}$  (unless otherwise noted)

| PARAMETER  |   | TEST CONDITIONS                           |   | MIN             | TYP         | MAX     | UNIT          |
|------------|---|---|---|-----------------|-------------|---------|---------------|
| $V_{OH}$   | High-level output voltage <sup>(1)</sup>        | $I_{OH} = -100 \mu\text{A}, V_I = V_{IH}$ | $V_{CCA} = V_{CCB} = 1.2\text{V to } 3.6\text{V}$ | $V_{CCO} - 0.2$ |             |         | V             |
|            |   | $I_{OH} = -3\text{mA}, V_I = V_{IH}$      | $V_{CCA} = V_{CCB} = 1.2\text{V}$                 |                 | 0.95        |         |               |
|            |   | $I_{OH} = -6\text{mA}, V_I = V_{IH}$      | $V_{CCA} = V_{CCB} = 1.4\text{V}$                 |                 | 1.05        |         |               |
|            |   | $I_{OH} = -8\text{mA}, V_I = V_{IH}$      | $V_{CCA} = V_{CCB} = 1.65\text{V}$                |                 | 1.2         |         |               |
|            |   | $I_{OH} = -9\text{mA}, V_I = V_{IH}$      | $V_{CCA} = V_{CCB} = 2.3\text{V}$                 |                 | 1.75        |         |               |
|            |   | $I_{OH} = -12\text{mA}, V_I = V_{IH}$     | $V_{CCA} = V_{CCB} = 3\text{V}$                   |                 | 2.3         |         |               |
| $V_{OL}$   | Low-level output voltage                        | $I_{OL} = 100 \mu\text{A}, V_I = V_{IL}$  | $V_{CCA} = V_{CCB} = 1.2\text{V to } 3.6\text{V}$ |                 |             | 0.2     | V             |
|            |   | $I_{OL} = 3\text{mA}, V_I = V_{IL}$       | $V_{CCA} = V_{CCB} = 1.2\text{V}$                 |                 | 0.15        |         |               |
|            |   | $I_{OL} = 6\text{mA}, V_I = V_{IL}$       | $V_{CCA} = V_{CCB} = 1.4\text{V}$                 |                 |             | 0.35    |               |
|            |   | $I_{OL} = 8\text{mA}, V_I = V_{IL}$       | $V_{CCA} = V_{CCB} = 1.65\text{V}$                |                 |             | 0.45    |               |
|            |   | $I_{OL} = 9\text{mA}, V_I = V_{IL}$       | $V_{CCA} = V_{CCB} = 2.3\text{V}$                 |                 |             | 0.55    |               |
|            |   | $I_{OL} = 12\text{mA}, V_I = V_{IL}$      | $V_{CCA} = V_{CCB} = 3\text{V}$                   |                 |             | 0.7     |               |
| $I_I$      | Control inputs                                  | $V_I = V_{CCA}$ or GND                    | $V_{CCA} = V_{CCB} = 1.2\text{V to } 3.6\text{V}$ |                 | $\pm 0.025$ | $\pm 1$ | $\mu\text{A}$ |
| $I_{BHL}$  | Bus-hold low sustaining current <sup>(5)</sup>  | $V_I = 0.42\text{V}$                      | $V_{CCA} = V_{CCB} = 1.2\text{V}$                 |                 | 25          |         | $\mu\text{A}$ |
|            |   | $V_I = 0.49\text{V}$                      | $V_{CCA} = V_{CCB} = 1.4\text{V}$                 | 15              |             |         |               |
|            |   | $V_I = 0.58\text{V}$                      | $V_{CCA} = V_{CCB} = 1.65\text{V}$                | 25              |             |         |               |
|            |   | $V_I = 0.7\text{V}$                       | $V_{CCA} = V_{CCB} = 2.3\text{V}$                 | 45              |             |         |               |
|            |   | $V_I = 0.8\text{V}$                       | $V_{CCA} = V_{CCB} = 3.3\text{V}$                 | 100             |             |         |               |
| $I_{BHH}$  | Bus-hold high sustaining current <sup>(6)</sup> | $V_I = 0.78\text{V}$                      | $V_{CCA} = V_{CCB} = 1.2\text{V}$                 |                 | -25         |         | $\mu\text{A}$ |
|            |   | $V_I = 0.91\text{V}$                      | $V_{CCA} = V_{CCB} = 1.4\text{V}$                 | -15             |             |         |               |
|            |   | $V_I = 1.07\text{V}$                      | $V_{CCA} = V_{CCB} = 1.65\text{V}$                | -25             |             |         |               |
|            |   | $V_I = 1.6\text{V}$                       | $V_{CCA} = V_{CCB} = 2.3\text{V}$                 | -45             |             |         |               |
|            |   | $V_I = 2\text{V}$                         | $V_{CCA} = V_{CCB} = 3.3\text{V}$                 | -100            |             |         |               |
| $I_{BHLO}$ | Bus-hold low overdrive current <sup>(3)</sup>   | $V_I = 0$ to $V_{CC}$                     | $V_{CCA} = V_{CCB} = 1.2\text{V}$                 |                 | 50          |         | $\mu\text{A}$ |
|            |   |   | $V_{CCA} = V_{CCB} = 1.6\text{V}$                 |                 | 125         |         |               |
|            |   |   | $V_{CCA} = V_{CCB} = 1.95\text{V}$                |                 | 200         |         |               |
|            |   |   | $V_{CCA} = V_{CCB} = 2.7\text{V}$                 |                 | 300         |         |               |
|            |   |   | $V_{CCA} = V_{CCB} = 3.6\text{V}$                 |                 | 500         |         |               |

## 5.5 Electrical Characteristics (续)

All typical limits apply over  $T_A = 25^\circ\text{C}$ , and all maximum and minimum limits apply over  $T_A = -40^\circ\text{C}$  to  $85^\circ\text{C}$  (unless otherwise noted)

| PARAMETER                |   | TEST CONDITIONS   |   | MIN    | TYP               | MAX       | UNIT          |               |               |
|--------------------------|---|---|---|--------|-------------------|-----------|---------------|---------------|---------------|
| $I_{BHHO}$               | Bus-hold high overdrive current <sup>(4)</sup>                        | $V_I = 0$ to $V_{CC}$   | $V_{CCA} = V_{CCB} = 1.2\text{V}$                                 |        |                   | -50       | $\mu\text{A}$ |               |               |
|                          |   |   | $V_{CCA} = V_{CCB} = 1.6\text{V}$                                 |        |                   | -125      |               |               |               |
|                          |   |   | $V_{CCA} = V_{CCB} = 1.95\text{V}$                                |        |                   | -200      |               |               |               |
|                          |   |   | $V_{CCA} = V_{CCB} = 2.7\text{V}$                                 |        |                   | -300      |               |               |               |
|                          |   |   | $V_{CCA} = V_{CCB} = 3.6\text{V}$                                 |        |                   | -500      |               |               |               |
| $I_{off}$                | Input/output power-off leakage current                                | $V_I = 0\text{V}$ to $3.6\text{V}$ ,<br>$V_O = 0\text{V}$ to $3.6\text{V}$  | $V_{CCA} = 0\text{V}$ ,<br>$V_{CCB} = 0\text{V}$ to $3.6\text{V}$ | A Port |                   | $\pm 0.1$ | $\pm 5$       | $\mu\text{A}$ |               |
|                          |   |   | $V_{CCA} = 0\text{V}$ to $3.6\text{V}$ ,<br>$V_{CCB} = 0\text{V}$ | B Port |                   | $\pm 0.1$ | $\pm 5$       |               |               |
| $I_{OZ}$                 | Off-state output current <sup>(1)</sup> <sup>(2)</sup> <sup>(7)</sup> | $V_O = V_{CCO}$ or GND,<br>$V_I = V_{CCI}$ or GND, $\overline{OE} = V_{IH}$ | $V_{CCA} = V_{CCB} = 3.6\text{V}$                                 |        | A Port,<br>B Port |           | $\pm 0.5$     | $\pm 5$       | $\mu\text{A}$ |
|                          |   |   | $V_{CCA} = 0\text{V}$ ,<br>$V_{CCB} = 3.6\text{V}$                |        | B Port            |           |               | $\pm 5$       |               |
|                          |   |   | $V_{CCA} = 3.6\text{V}$ ,<br>$V_{CCB} = 0\text{V}$                |        | A Port            |           |               | $\pm 5$       |               |
| $I_{CCA}$                | Supply current A port <sup>(2)</sup>                                  | $V_I = V_{CCI}$ or GND, $I_O = 0$   | $V_{CCA} = V_{CCB} = 1.2\text{V}$ to $3.6\text{V}$                |        |                   |           | 8             | $\mu\text{A}$ |               |
|                          |   |   | $V_{CCA} = 0\text{V}$ , $V_{CCB} = 3.6\text{V}$                   |        |                   |           | -2            |               |               |
|                          |   |   | $V_{CCA} = 3.6\text{V}$ , $V_{CCB} = 0\text{V}$                   |        |                   |           | 8             |               |               |
| $I_{CCB}$                | Supply current B port <sup>(2)</sup>                                  | $V_I = V_{CCI}$ or GND, $I_O = 0$   | $V_{CCA} = V_{CCB} = 1.2\text{V}$ to $3.6\text{V}$                |        |                   |           | 8             | $\mu\text{A}$ |               |
|                          |   |   | $V_{CCA} = 0\text{V}$ , $V_{CCB} = 3.6\text{V}$                   |        |                   |           | 8             |               |               |
|                          |   |   | $V_{CCA} = 3.6\text{V}$ , $V_{CCB} = 0\text{V}$                   |        |                   |           | -2            |               |               |
| $I_{CCA}^+$<br>$I_{CCB}$ | Combined supply current <sup>(2)</sup>                                | $V_I = V_{CCI}$ or GND, $I_O = 0$   | $V_{CCA} = V_{CCB} = 1.2\text{V}$ to $3.6\text{V}$                |        |                   |           | 16            | $\mu\text{A}$ |               |
| $C_i$                    | Input capacitance control pins  | $V_I = 3.3\text{V}$ or GND  | $V_{CCA} = V_{CCB} = 3.3\text{V}$                                 |        |                   | 3.5       | 4.5           | pF            |               |
| $C_{io}$                 | Input/output capacitance a or b port                                  | $V_O = 3.3\text{V}$ or GND  | $V_{CCA} = V_{CCB} = 3.3\text{V}$                                 |        |                   | 6         | 7             | pF            |               |

(1)  $V_{CCO}$  is the  $V_{CC}$  associated with the output port.

(2)  $V_{CCI}$  is the  $V_{CC}$  associated with the input port.

(3) An external driver must source at least  $I_{BHLO}$  to switch this node from low to high.

(4) An external driver must sink at least  $I_{BHHO}$  to switch this node from high to low.

(5) The bus-hold circuit can sink at least the minimum low sustaining current at  $V_{IL}$  max.  $I_{BHL}$  should be measured after lowering  $V_{IN}$  to GND and then raising it to  $V_{IL}$  max.

(6) The bus-hold circuit can source at least the minimum high sustaining current at  $V_{IH}$  min.  $I_{BHH}$  should be measured after raising  $V_{IN}$  to  $V_{CC}$  and then lowering it to  $V_{IH}$  min.

(7) For I/O ports, the parameter  $I_{OZ}$  includes the input leakage current.

## 5.6 Switching Characteristics, $V_{CCA} = 1.2V$

$T_A = 25^\circ C$  (see 图 6-1)

| PARAMETER                | FROM (INPUT)    | TO (OUTPUT) | TEST CONDITIONS  | MIN | TYP | MAX | UNIT |
|--------------------------|-----------------|-------------|------------------|-----|-----|-----|------|
| $t_{PLH}$ ,<br>$t_{PHL}$ | A               | B           | $V_{CCB} = 1.2V$ |     | 3.1 |     | ns   |
|                          |                 |             | $V_{CCB} = 1.5V$ |     | 2.6 |     |      |
|                          |                 |             | $V_{CCB} = 1.8V$ |     | 2.5 |     |      |
|                          |                 |             | $V_{CCB} = 2.5V$ |     | 3   |     |      |
|                          |                 |             | $V_{CCB} = 3.3V$ |     | 3.5 |     |      |
| $t_{PLH}$ ,<br>$t_{PHL}$ | B               | A           | $V_{CCB} = 1.2V$ |     | 3.1 |     | ns   |
|                          |                 |             | $V_{CCB} = 1.5V$ |     | 2.7 |     |      |
|                          |                 |             | $V_{CCB} = 1.8V$ |     | 2.5 |     |      |
|                          |                 |             | $V_{CCB} = 2.5V$ |     | 2.4 |     |      |
|                          |                 |             | $V_{CCB} = 3.3V$ |     | 2.3 |     |      |
| $t_{PZH}$ ,<br>$t_{PZL}$ | $\overline{OE}$ | A           | $V_{CCB} = 1.2V$ |     | 5.3 |     | ns   |
|                          |                 |             | $V_{CCB} = 1.5V$ |     | 5.3 |     |      |
|                          |                 |             | $V_{CCB} = 1.8V$ |     | 5.3 |     |      |
|                          |                 |             | $V_{CCB} = 2.5V$ |     | 5.3 |     |      |
|                          |                 |             | $V_{CCB} = 3.3V$ |     | 5.3 |     |      |
| $t_{PZH}$ ,<br>$t_{PZL}$ | $\overline{OE}$ | B           | $V_{CCB} = 1.2V$ |     | 5.1 |     | ns   |
|                          |                 |             | $V_{CCB} = 1.5V$ |     | 4   |     |      |
|                          |                 |             | $V_{CCB} = 1.8V$ |     | 3.5 |     |      |
|                          |                 |             | $V_{CCB} = 2.5V$ |     | 3.2 |     |      |
|                          |                 |             | $V_{CCB} = 3.3V$ |     | 3.1 |     |      |
| $t_{PHZ}$ ,<br>$t_{PLZ}$ | $\overline{OE}$ | A           | $V_{CCB} = 1.2V$ |     | 4.8 |     | ns   |
|                          |                 |             | $V_{CCB} = 1.5V$ |     | 4.8 |     |      |
|                          |                 |             | $V_{CCB} = 1.8V$ |     | 4.8 |     |      |
|                          |                 |             | $V_{CCB} = 2.5V$ |     | 4.8 |     |      |
|                          |                 |             | $V_{CCB} = 3.3V$ |     | 4.8 |     |      |
| $t_{PHZ}$ ,<br>$t_{PLZ}$ | $\overline{OE}$ | B           | $V_{CCB} = 1.2V$ |     | 4.7 |     | ns   |
|                          |                 |             | $V_{CCB} = 1.5V$ |     | 4   |     |      |
|                          |                 |             | $V_{CCB} = 1.8V$ |     | 4.1 |     |      |
|                          |                 |             | $V_{CCB} = 2.5V$ |     | 4.3 |     |      |
|                          |                 |             | $V_{CCB} = 3.3V$ |     | 5.1 |     |      |



### 5.7 Switching Characteristics, $V_{CCA} = 1.5V \pm 0.1V$

All typical limits apply over  $T_A = 25^\circ C$ , and all maximum and minimum limits apply over  $T_A = -40^\circ C$  to  $85^\circ C$  (unless otherwise noted) (see [图 6-1](#))

| PARAMETER                | FROM (INPUT)    | TO (OUTPUT) | TEST CONDITIONS  | MIN | TYP | MAX | UNIT |
|--------------------------|-----------------|-------------|------------------|-----|-----|-----|------|
| $t_{PLH}$ ,<br>$t_{PHL}$ | A               | B           | $V_{CCB} = 1.2V$ |     | 2.7 |     | ns   |
|                          |                 |             | $V_{CCB} = 1.5V$ | 0.5 |     | 5.4 |      |
|                          |                 |             | $V_{CCB} = 1.8V$ | 0.5 |     | 4.6 |      |
|                          |                 |             | $V_{CCB} = 2.5V$ | 0.5 |     | 4.9 |      |
|                          |                 |             | $V_{CCB} = 3.3V$ | 0.5 |     | 6.8 |      |
| $t_{PLH}$ ,<br>$t_{PHL}$ | B               | A           | $V_{CCB} = 1.2V$ |     | 2.6 |     | ns   |
|                          |                 |             | $V_{CCB} = 1.5V$ | 0.5 |     | 5.4 |      |
|                          |                 |             | $V_{CCB} = 1.8V$ | 0.5 |     | 5.1 |      |
|                          |                 |             | $V_{CCB} = 2.5V$ | 0.5 |     | 4.7 |      |
|                          |                 |             | $V_{CCB} = 3.3V$ | 0.5 |     | 4.5 |      |
| $t_{PZH}$ ,<br>$t_{PZL}$ | $\overline{OE}$ | A           | $V_{CCB} = 1.2V$ |     | 3.7 |     | ns   |
|                          |                 |             | $V_{CCB} = 1.5V$ | 1.1 |     | 8.7 |      |
|                          |                 |             | $V_{CCB} = 1.8V$ | 1.1 |     | 8.7 |      |
|                          |                 |             | $V_{CCB} = 2.5V$ | 1.1 |     | 8.7 |      |
|                          |                 |             | $V_{CCB} = 3.3V$ | 1.1 |     | 8.7 |      |
| $t_{PZH}$ ,<br>$t_{PZL}$ | $\overline{OE}$ | B           | $V_{CCB} = 1.2V$ |     | 4.8 |     | ns   |
|                          |                 |             | $V_{CCB} = 1.5V$ | 1.1 |     | 7.6 |      |
|                          |                 |             | $V_{CCB} = 1.8V$ | 1.1 |     | 7.1 |      |
|                          |                 |             | $V_{CCB} = 2.5V$ | 1.1 |     | 5.6 |      |
|                          |                 |             | $V_{CCB} = 3.3V$ | 1.1 |     | 5.2 |      |
| $t_{PHZ}$ ,<br>$t_{PLZ}$ | $\overline{OE}$ | A           | $V_{CCB} = 1.2V$ |     | 3.1 |     | ns   |
|                          |                 |             | $V_{CCB} = 1.5V$ | 0.5 |     | 8.6 |      |
|                          |                 |             | $V_{CCB} = 1.8V$ | 0.5 |     | 8.6 |      |
|                          |                 |             | $V_{CCB} = 2.5V$ | 0.5 |     | 8.6 |      |
|                          |                 |             | $V_{CCB} = 3.3V$ | 0.5 |     | 8.6 |      |
| $t_{PHZ}$ ,<br>$t_{PLZ}$ | $\overline{OE}$ | B           | $V_{CCB} = 1.2V$ |     | 4.1 |     | ns   |
|                          |                 |             | $V_{CCB} = 1.5V$ | 0.5 |     | 8.4 |      |
|                          |                 |             | $V_{CCB} = 1.8V$ | 0.5 |     | 7.6 |      |
|                          |                 |             | $V_{CCB} = 2.5V$ | 0.5 |     | 7.2 |      |
|                          |                 |             | $V_{CCB} = 3.3V$ | 0.5 |     | 7.8 |      |

## 5.8 Switching Characteristics, $V_{CCA} = 1.8V \pm 0.15V$

All typical limits apply over  $T_A = 25^\circ C$ , and all maximum and minimum limits apply over  $T_A = -40^\circ C$  to  $85^\circ C$  (unless otherwise noted) (see [图 6-1](#))

| PARAMETER                | FROM (INPUT)    | TO (OUTPUT) | TEST CONDITIONS  | MIN | TYP | MAX | UNIT |
|--------------------------|-----------------|-------------|------------------|-----|-----|-----|------|
| $t_{PLH}$ ,<br>$t_{PHL}$ | A               | B           | $V_{CCB} = 1.2V$ |     | 2.5 |     | ns   |
|                          |                 |             | $V_{CCB} = 1.5V$ | 0.5 |     | 5.1 |      |
|                          |                 |             | $V_{CCB} = 1.8V$ | 0.5 |     | 4.4 |      |
|                          |                 |             | $V_{CCB} = 2.5V$ | 0.5 |     | 4   |      |
|                          |                 |             | $V_{CCB} = 3.3V$ | 0.5 |     | 3.9 |      |
| $t_{PLH}$ ,<br>$t_{PHL}$ | B               | A           | $V_{CCB} = 1.2V$ |     | 2.5 |     | ns   |
|                          |                 |             | $V_{CCB} = 1.5V$ | 0.5 |     | 4.6 |      |
|                          |                 |             | $V_{CCB} = 1.8V$ | 0.5 |     | 4.4 |      |
|                          |                 |             | $V_{CCB} = 2.5V$ | 0.5 |     | 3.9 |      |
|                          |                 |             | $V_{CCB} = 3.3V$ | 0.5 |     | 3.7 |      |
| $t_{PZH}$ ,<br>$t_{PZL}$ | $\overline{OE}$ | A           | $V_{CCB} = 1.2V$ |     | 3   |     | ns   |
|                          |                 |             | $V_{CCB} = 1.5V$ | 1   |     | 6.8 |      |
|                          |                 |             | $V_{CCB} = 1.8V$ | 1   |     | 6.8 |      |
|                          |                 |             | $V_{CCB} = 2.5V$ | 1   |     | 6.8 |      |
|                          |                 |             | $V_{CCB} = 3.3V$ | 1   |     | 6.8 |      |
| $t_{PZH}$ ,<br>$t_{PZL}$ | $\overline{OE}$ | B           | $V_{CCB} = 1.2V$ |     | 4.6 |     | ns   |
|                          |                 |             | $V_{CCB} = 1.5V$ | 1.1 |     | 8.2 |      |
|                          |                 |             | $V_{CCB} = 1.8V$ | 1   |     | 6.7 |      |
|                          |                 |             | $V_{CCB} = 2.5V$ | 0.5 |     | 5.1 |      |
|                          |                 |             | $V_{CCB} = 3.3V$ | 0.5 |     | 4.5 |      |
| $t_{PHZ}$ ,<br>$t_{PLZ}$ | $\overline{OE}$ | A           | $V_{CCB} = 1.2V$ |     | 2.8 |     | ns   |
|                          |                 |             | $V_{CCB} = 1.5V$ | 0.5 |     | 7.1 |      |
|                          |                 |             | $V_{CCB} = 1.8V$ | 0.5 |     | 7.1 |      |
|                          |                 |             | $V_{CCB} = 2.5V$ | 0.5 |     | 7.1 |      |
|                          |                 |             | $V_{CCB} = 3.3V$ | 0.5 |     | 7.1 |      |
| $t_{PHZ}$ ,<br>$t_{PLZ}$ | $\overline{OE}$ | B           | $V_{CCB} = 1.2V$ |     | 3.9 |     | ns   |
|                          |                 |             | $V_{CCB} = 1.5V$ | 0.5 |     | 7.8 |      |
|                          |                 |             | $V_{CCB} = 1.8V$ | 0.5 |     | 6.9 |      |
|                          |                 |             | $V_{CCB} = 2.5V$ | 0.5 |     | 6   |      |
|                          |                 |             | $V_{CCB} = 3.3V$ | 0.5 |     | 5.8 |      |

## 5.9 Switching Characteristics, $V_{CCA} = 2.5V \pm 0.2V$

All typical limits apply over  $T_A = 25^\circ C$ , and all maximum and minimum limits apply over  $T_A = -40^\circ C$  to  $85^\circ C$  (unless otherwise noted) (see [图 6-1](#))

| PARAMETER                | FROM (INPUT)    | TO (OUTPUT) | TEST CONDITIONS  | MIN | TYP | MAX | UNIT |
|--------------------------|-----------------|-------------|------------------|-----|-----|-----|------|
| $t_{PLH}$ ,<br>$t_{PHL}$ | A               | B           | $V_{CCB} = 1.2V$ |     | 2.4 |     | ns   |
|                          |                 |             | $V_{CCB} = 1.5V$ | 0.5 |     | 4.7 |      |
|                          |                 |             | $V_{CCB} = 1.8V$ | 0.5 |     | 3.9 |      |
|                          |                 |             | $V_{CCB} = 2.5V$ | 0.5 |     | 3.1 |      |
|                          |                 |             | $V_{CCB} = 3.3V$ | 0.5 |     | 2.8 |      |
| $t_{PLH}$ ,<br>$t_{PHL}$ | B               | A           | $V_{CCB} = 1.2V$ |     | 3   |     | ns   |
|                          |                 |             | $V_{CCB} = 1.5V$ | 0.5 |     | 4.9 |      |
|                          |                 |             | $V_{CCB} = 1.8V$ | 0.5 |     | 4   |      |
|                          |                 |             | $V_{CCB} = 2.5V$ | 0.5 |     | 3.1 |      |
|                          |                 |             | $V_{CCB} = 3.3V$ | 0.5 |     | 2.9 |      |
| $t_{PZH}$ ,<br>$t_{PZL}$ | $\overline{OE}$ | A           | $V_{CCB} = 1.2V$ |     | 2.2 |     | ns   |
|                          |                 |             | $V_{CCB} = 1.5V$ | 0.5 |     | 4.8 |      |
|                          |                 |             | $V_{CCB} = 1.8V$ | 0.5 |     | 4.8 |      |
|                          |                 |             | $V_{CCB} = 2.5V$ | 0.5 |     | 4.8 |      |
|                          |                 |             | $V_{CCB} = 3.3V$ | 0.5 |     | 4.8 |      |
| $t_{PZH}$ ,<br>$t_{PZL}$ | $\overline{OE}$ | B           | $V_{CCB} = 1.2V$ |     | 4.5 |     | ns   |
|                          |                 |             | $V_{CCB} = 1.5V$ | 1.1 |     | 7.9 |      |
|                          |                 |             | $V_{CCB} = 1.8V$ | 0.5 |     | 6.4 |      |
|                          |                 |             | $V_{CCB} = 2.5V$ | 0.5 |     | 4.6 |      |
|                          |                 |             | $V_{CCB} = 3.3V$ | 0.5 |     | 4   |      |
| $t_{PHZ}$ ,<br>$t_{PLZ}$ | $\overline{OE}$ | A           | $V_{CCB} = 1.2V$ |     | 1.8 |     | ns   |
|                          |                 |             | $V_{CCB} = 1.5V$ | 0.5 |     | 5.1 |      |
|                          |                 |             | $V_{CCB} = 1.8V$ | 0.5 |     | 5.1 |      |
|                          |                 |             | $V_{CCB} = 2.5V$ | 0.5 |     | 5.1 |      |
|                          |                 |             | $V_{CCB} = 3.3V$ | 0.5 |     | 5.1 |      |
| $t_{PHZ}$ ,<br>$t_{PLZ}$ | $\overline{OE}$ | B           | $V_{CCB} = 1.2V$ |     | 3.6 |     | ns   |
|                          |                 |             | $V_{CCB} = 1.5V$ | 0.5 |     | 7.1 |      |
|                          |                 |             | $V_{CCB} = 1.8V$ | 0.5 |     | 6.3 |      |
|                          |                 |             | $V_{CCB} = 2.5V$ | 0.5 |     | 5.1 |      |
|                          |                 |             | $V_{CCB} = 3.3V$ | 0.5 |     | 3.9 |      |

## 5.10 Switching Characteristics, $V_{CCA} = 3.3V \pm 0.3V$

All typical limits apply over  $T_A = 25^\circ C$ , and all maximum and minimum limits apply over  $T_A = -40^\circ C$  to  $85^\circ C$  (unless otherwise noted) (see [图 6-1](#))

| PARAMETER                | FROM (INPUT)    | TO (OUTPUT) | TEST CONDITIONS  | MIN | TYP | MAX | UNIT |
|--------------------------|-----------------|-------------|------------------|-----|-----|-----|------|
| $t_{PLH}$ ,<br>$t_{PHL}$ | A               | B           | $V_{CCB} = 1.2V$ |     | 2.3 |     | ns   |
|                          |                 |             | $V_{CCB} = 1.5V$ | 0.5 |     | 4.5 |      |
|                          |                 |             | $V_{CCB} = 1.8V$ | 0.5 |     | 3.7 |      |
|                          |                 |             | $V_{CCB} = 2.5V$ | 0.5 |     | 2.9 |      |
|                          |                 |             | $V_{CCB} = 3.3V$ | 0.5 |     | 2.5 |      |
| $t_{PLH}$ ,<br>$t_{PHL}$ | B               | A           | $V_{CCB} = 1.2V$ |     | 3.5 |     | ns   |
|                          |                 |             | $V_{CCB} = 1.5V$ | 0.5 |     | 6.8 |      |
|                          |                 |             | $V_{CCB} = 1.8V$ | 0.5 |     | 3.9 |      |
|                          |                 |             | $V_{CCB} = 2.5V$ | 0.5 |     | 2.8 |      |
|                          |                 |             | $V_{CCB} = 3.3V$ | 0.5 |     | 2.5 |      |
| $t_{PZH}$ ,<br>$t_{PZL}$ | $\overline{OE}$ | A           | $V_{CCB} = 1.2V$ |     | 2   |     | ns   |
|                          |                 |             | $V_{CCB} = 1.5V$ | 0.5 |     | 4   |      |
|                          |                 |             | $V_{CCB} = 1.8V$ | 0.5 |     | 4   |      |
|                          |                 |             | $V_{CCB} = 2.5V$ | 0.5 |     | 4   |      |
|                          |                 |             | $V_{CCB} = 3.3V$ | 0.5 |     | 4   |      |
| $t_{PZH}$ ,<br>$t_{PZL}$ | $\overline{OE}$ | B           | $V_{CCB} = 1.2V$ |     | 4.5 |     | ns   |
|                          |                 |             | $V_{CCB} = 1.5V$ | 1.1 |     | 7.8 |      |
|                          |                 |             | $V_{CCB} = 1.8V$ | 0.5 |     | 6.2 |      |
|                          |                 |             | $V_{CCB} = 2.5V$ | 0.5 |     | 4.5 |      |
|                          |                 |             | $V_{CCB} = 3.3V$ | 0.5 |     | 3.9 |      |
| $t_{PHZ}$ ,<br>$t_{PLZ}$ | $\overline{OE}$ | A           | $V_{CCB} = 1.2V$ |     | 1.7 |     | ns   |
|                          |                 |             | $V_{CCB} = 1.5V$ | 0.5 |     | 4   |      |
|                          |                 |             | $V_{CCB} = 1.8V$ | 0.5 |     | 4   |      |
|                          |                 |             | $V_{CCB} = 2.5V$ | 0.5 |     | 4   |      |
|                          |                 |             | $V_{CCB} = 3.3V$ | 0.5 |     | 4   |      |
| $t_{PHZ}$ ,<br>$t_{PLZ}$ | $\overline{OE}$ | B           | $V_{CCB} = 1.2V$ |     | 3.4 |     | ns   |
|                          |                 |             | $V_{CCB} = 1.5V$ | 0.5 |     | 6.9 |      |
|                          |                 |             | $V_{CCB} = 1.8V$ | 0.5 |     | 6   |      |
|                          |                 |             | $V_{CCB} = 2.5V$ | 0.5 |     | 4.8 |      |
|                          |                 |             | $V_{CCB} = 3.3V$ | 0.5 |     | 4.2 |      |

## 5.11 Operating Characteristics

T<sub>A</sub> = 25°C

| PARAMETER                                  |  | FROM<br>(INPUT) | TO<br>(OUTPUT) | TEST CONDITIONS  | TYP  | UNIT |    |
|--|--|-----------------|----------------|--|--|------|----|
| C <sub>pdA</sub>                           | Power dissipation capacitance per transceiver <sup>(1)</sup> port A - outputs enabled  | A               | B              | C <sub>L</sub> = 0pF,<br>f = 10MHz,<br>t <sub>r</sub> = t <sub>f</sub> = 1ns | V <sub>CCA</sub> = V <sub>CCB</sub> = 1.2V | 1    | pF |
|  |  |                 |                |  | V <sub>CCA</sub> = V <sub>CCB</sub> = 1.5V | 1    |    |
|  |  |                 |                |  | V <sub>CCA</sub> = V <sub>CCB</sub> = 1.8V | 1    |    |
|  |  |                 |                |  | V <sub>CCA</sub> = V <sub>CCB</sub> = 2.5V | 1    |    |
|  |  |                 |                |  | V <sub>CCA</sub> = V <sub>CCB</sub> = 3.3V | 1    |    |
|  | Power dissipation capacitance per transceiver <sup>(1)</sup> port A - outputs disabled | A               | B              | C <sub>L</sub> = 0pF,<br>f = 10MHz,<br>t <sub>r</sub> = t <sub>f</sub> = 1ns | V <sub>CCA</sub> = V <sub>CCB</sub> = 1.2V | 1    |    |
|  |  |                 |                |  | V <sub>CCA</sub> = V <sub>CCB</sub> = 1.5V | 1    |    |
|  |  |                 |                |  | V <sub>CCA</sub> = V <sub>CCB</sub> = 1.8V | 1    |    |
|  |  |                 |                |  | V <sub>CCA</sub> = V <sub>CCB</sub> = 2.5V | 1    |    |
|  |  |                 |                |  | V <sub>CCA</sub> = V <sub>CCB</sub> = 3.3V | 1    |    |
|  | Power dissipation capacitance per transceiver <sup>(1)</sup> port A - outputs enabled  | B               | A              | C <sub>L</sub> = 0pF,<br>f = 10MHz,<br>t <sub>r</sub> = t <sub>f</sub> = 1ns | V <sub>CCA</sub> = V <sub>CCB</sub> = 1.2V | 12   |    |
|  |  |                 |                |  | V <sub>CCA</sub> = V <sub>CCB</sub> = 1.5V | 12   |    |
|  |  |                 |                |  | V <sub>CCA</sub> = V <sub>CCB</sub> = 1.8V | 12   |    |
|  |  |                 |                |  | V <sub>CCA</sub> = V <sub>CCB</sub> = 2.5V | 13   |    |
|  |  |                 |                |  | V <sub>CCA</sub> = V <sub>CCB</sub> = 3.3V | 14   |    |
|  | Power dissipation capacitance per transceiver <sup>(1)</sup> port A - outputs disabled | B               | A              | C <sub>L</sub> = 0pF,<br>f = 10MHz,<br>t <sub>r</sub> = t <sub>f</sub> = 1ns | V <sub>CCA</sub> = V <sub>CCB</sub> = 1.2V | 1    |    |
| V <sub>CCA</sub> = V <sub>CCB</sub> = 1.5V |  |                 |                |  | 1  |      |    |
| V <sub>CCA</sub> = V <sub>CCB</sub> = 1.8V |  |                 |                |  | 1  |      |    |
| V <sub>CCA</sub> = V <sub>CCB</sub> = 2.5V |  |                 |                |  | 1  |      |    |
| V <sub>CCA</sub> = V <sub>CCB</sub> = 3.3V |  |                 |                |  | 1  |      |    |
| C <sub>pdB</sub>                           | Power dissipation capacitance per transceiver <sup>(1)</sup> port B - outputs enabled  | A               | B              | C <sub>L</sub> = 0pF,<br>f = 10MHz,<br>t <sub>r</sub> = t <sub>f</sub> = 1ns | V <sub>CCA</sub> = V <sub>CCB</sub> = 1.2V | 12   | pF |
|  |  |                 |                |  | V <sub>CCA</sub> = V <sub>CCB</sub> = 1.5V | 12   |    |
|  |  |                 |                |  | V <sub>CCA</sub> = V <sub>CCB</sub> = 1.8V | 12   |    |
|  |  |                 |                |  | V <sub>CCA</sub> = V <sub>CCB</sub> = 2.5V | 13   |    |
|  |  |                 |                |  | V <sub>CCA</sub> = V <sub>CCB</sub> = 3.3V | 14   |    |
|  | Power dissipation capacitance per transceiver <sup>(1)</sup> port B - outputs disabled | A               | B              | C <sub>L</sub> = 0pF,<br>f = 10MHz,<br>t <sub>r</sub> = t <sub>f</sub> = 1ns | V <sub>CCA</sub> = V <sub>CCB</sub> = 1.2V | 1    |    |
|  |  |                 |                |  | V <sub>CCA</sub> = V <sub>CCB</sub> = 1.5V | 1    |    |
|  |  |                 |                |  | V <sub>CCA</sub> = V <sub>CCB</sub> = 1.8V | 1    |    |
|  |  |                 |                |  | V <sub>CCA</sub> = V <sub>CCB</sub> = 2.5V | 1    |    |
|  |  |                 |                |  | V <sub>CCA</sub> = V <sub>CCB</sub> = 3.3V | 1    |    |
|  | Power dissipation capacitance per transceiver <sup>(1)</sup> port B - outputs enabled  | B               | A              | C <sub>L</sub> = 0pF,<br>f = 10MHz,<br>t <sub>r</sub> = t <sub>f</sub> = 1ns | V <sub>CCA</sub> = V <sub>CCB</sub> = 1.2V | 1    |    |
|  |  |                 |                |  | V <sub>CCA</sub> = V <sub>CCB</sub> = 1.5V | 1    |    |
|  |  |                 |                |  | V <sub>CCA</sub> = V <sub>CCB</sub> = 1.8V | 1    |    |
|  |  |                 |                |  | V <sub>CCA</sub> = V <sub>CCB</sub> = 2.5V | 1    |    |
|  |  |                 |                |  | V <sub>CCA</sub> = V <sub>CCB</sub> = 3.3V | 1    |    |
|  | Power dissipation capacitance per transceiver <sup>(1)</sup> port B - outputs disabled | B               | A              | C <sub>L</sub> = 0pF,<br>f = 10MHz,<br>t <sub>r</sub> = t <sub>f</sub> = 1ns | V <sub>CCA</sub> = V <sub>CCB</sub> = 1.2V | 1    |    |
| V <sub>CCA</sub> = V <sub>CCB</sub> = 1.5V |  |                 |                |  | 1  |      |    |
| V <sub>CCA</sub> = V <sub>CCB</sub> = 1.8V |  |                 |                |  | 1  |      |    |
| V <sub>CCA</sub> = V <sub>CCB</sub> = 2.5V |  |                 |                |  | 1  |      |    |
| V <sub>CCA</sub> = V <sub>CCB</sub> = 3.3V |  |                 |                |  | 1  |      |    |

(1) See to TI application report, *CMOS Power Consumption and Cpd Calculation* (SCAA035).

## 5.12 Typical Characteristics

T<sub>A</sub> = 25°C



图 5-1. Typical Propagation Delay (A to B) vs Load Capacitance



图 5-2. Typical Propagation Delay (A to B) vs Load Capacitance

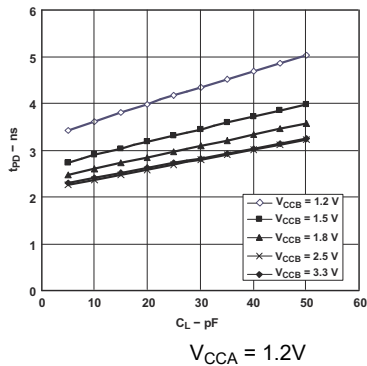

图 5-3. Typical Propagation Delay (A to B) vs Load Capacitance

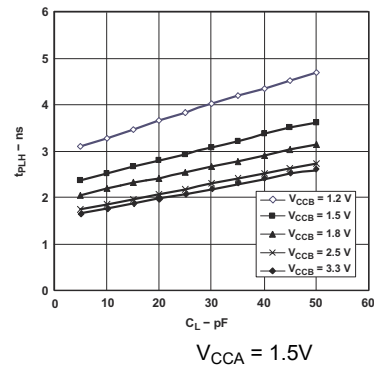

图 5-4. Typical Propagation Delay (A to B) vs Load Capacitance

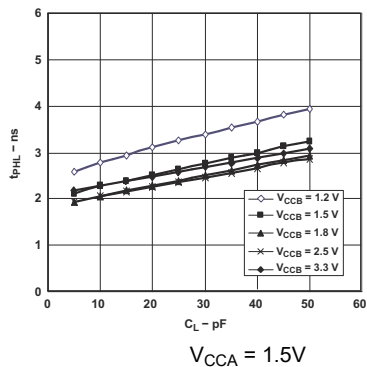

图 5-5. Typical Propagation Delay (A to B) vs Load Capacitance

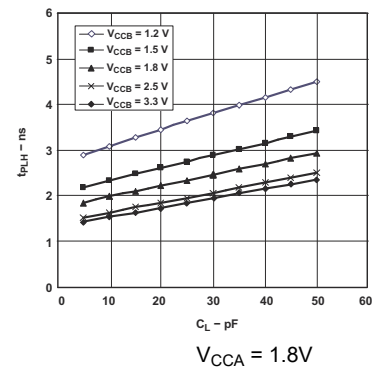

图 5-6. Typical Propagation Delay (A to B) vs Load Capacitance

### 5.12 Typical Characteristics (continued)

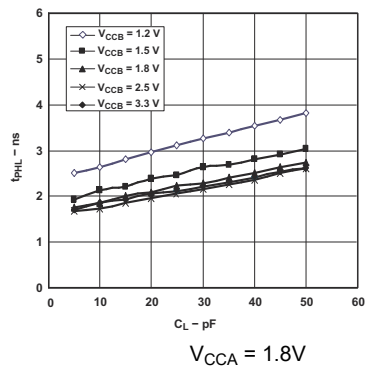
$T_A = 25^\circ\text{C}$

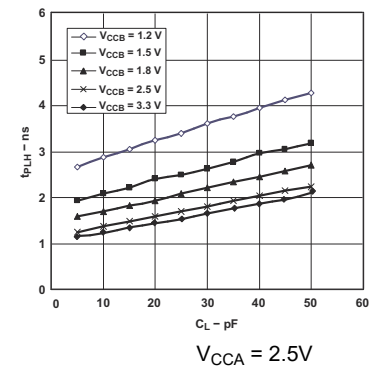

图 5-7. Typical Propagation Delay (A to B) vs Load Capacitance



图 5-8. Typical Propagation Delay (A to B) vs Load Capacitance

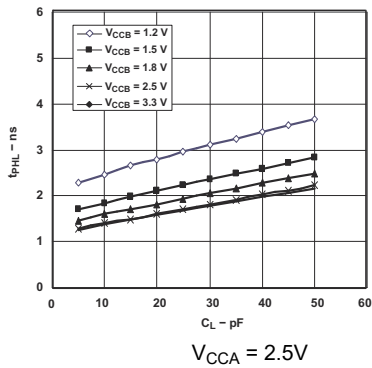

图 5-9. Typical Propagation Delay (A to B) vs Load Capacitance

## 6 Parameter Measurement Information

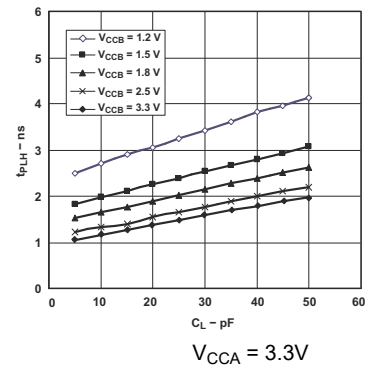

LOAD CIRCUIT

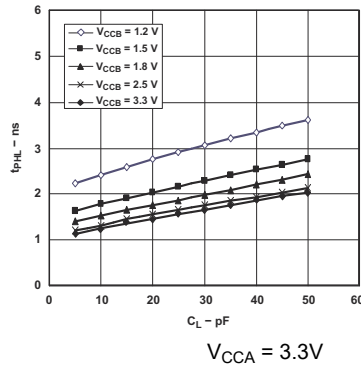
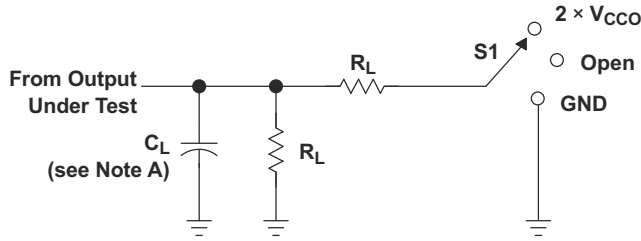
| TEST              | S1                 |
|-------------------|--------------------|
| $t_{pd}$          | Open               |
| $t_{PLZ}/t_{PZL}$ | $2 \times V_{CCO}$ |
| $t_{PHZ}/t_{PZH}$ | GND                |

| $V_{CCO}$          | $C_L$ | $R_L$        | $V_{TP}$ |
|--------------------|-------|--------------|----------|
| 1.2 V              | 15 pF | 2 k $\Omega$ | 0.1 V    |
| 1.5 V $\pm$ 0.1 V  | 15 pF | 2 k $\Omega$ | 0.1 V    |
| 1.8 V $\pm$ 0.15 V | 15 pF | 2 k $\Omega$ | 0.15 V   |
| 2.5 V $\pm$ 0.2 V  | 15 pF | 2 k $\Omega$ | 0.15 V   |
| 3.3 V $\pm$ 0.3 V  | 15 pF | 2 k $\Omega$ | 0.3 V    |

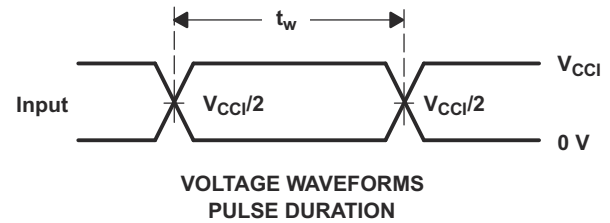

VOLTAGE WAVEFORMS PULSE DURATION

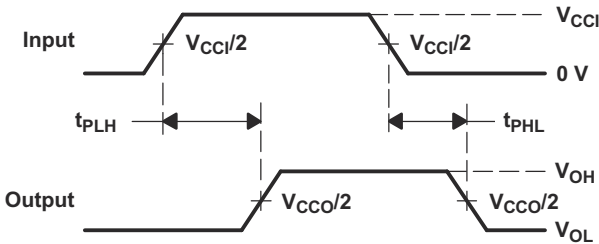

VOLTAGE WAVEFORMS PROPAGATION DELAY TIMES

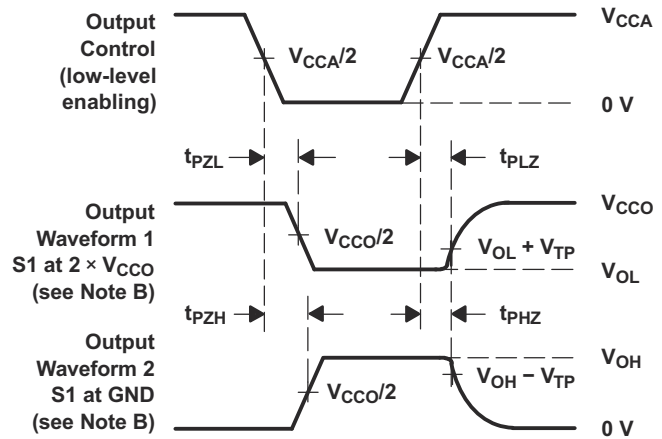

VOLTAGE WAVEFORMS ENABLE AND DISABLE TIMES

- NOTES:
- A.  $C_L$  includes probe and jig capacitance.
  - B. Waveform 1 is for an output with internal conditions such that the output is low except when disabled by the output control. Waveform 2 is for an output with internal conditions such that the output is high, except when disabled by the output control.
  - C. All input pulses are supplied by generators having the following characteristics:  $PRR \leq 10$  MHz,  $Z_O = 50 \Omega$ ,  $dv/dt \geq 1$  V/ns.
  - D. The outputs are measured one at a time, with one transition per measurement.
  - E.  $t_{PLZ}$  and  $t_{PHZ}$  are the same as  $t_{dis}$ .
  - F.  $t_{PZL}$  and  $t_{PZH}$  are the same as  $t_{en}$ .
  - G.  $t_{PLH}$  and  $t_{PHL}$  are the same as  $t_{pd}$ .
  - H.  $V_{CC1}$  is the  $V_{CC}$  associated with the input port.
  - I.  $V_{CCO}$  is the  $V_{CC}$  associated with the output port.

图 6-1. Load Circuit and Voltage Waveforms



## 7 Detailed Description

### 7.1 Overview

The SN74AVCH8T245 is an 8-bit, dual supply noninverting bidirectional voltage level translator. Pins A1 through A4, and the control pins (DIR and  $\overline{OE}$ ) are referenced to  $V_{CCA}$ , while pins B1 through B4 are referenced to  $V_{CCB}$ . Both the A port and B port can accept I/O voltages ranging from 1.2V to 3.6V. With  $\overline{OE}$  set to low, a high on DIR allows data transmission from Port A to Port B, and a low on DIR allows data transmission from Port B to Port A. When  $\overline{OE}$  is set to high, both Port A and Port B outputs are in the high-impedance state. For more information, see [AVC Logic Family Technology and Application](#).

### 7.2 Functional Block Diagram



图 7-1. Logic Diagram (Positive Logic)

### 7.3 Feature Description

#### 7.3.1 Fully Configurable Dual-Rail Design

Both  $V_{CCA}$  and  $V_{CCB}$  can be supplied at any voltage from 1.2V to 3.6V, making the device an excellent choice for translating between any of the low voltage nodes: 1.2V, 1.8V, 2.5V, and 3.3V.

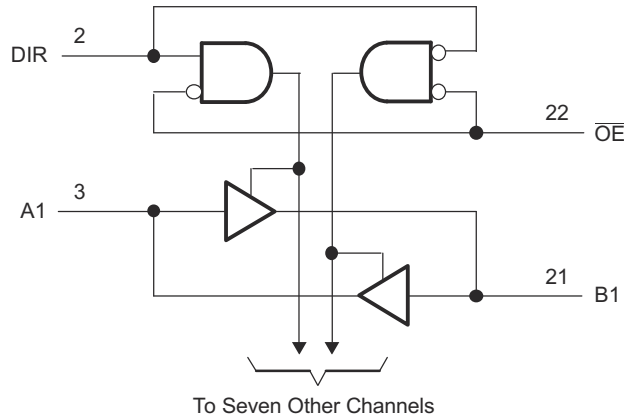
表 7-1. Typical Total Static Power Consumption ( $I_{CCA} + I_{CCB}$ )

| $V_{CCB}$ | $V_{CCA}$ |      |      |      |      |      | UNIT |
|-----------|-----------|------|------|------|------|------|------|
|           | 0V        | 1.2V | 1.5V | 1.8V | 2.5V | 3.3V |      |
| 0V        | 0         | <0.5 | <0.5 | <0.5 | <0.5 | <0.5 | μA   |
| 1.2V      | <0.5      | <1   | <1   | <1   | <1   | 1    |      |
| 1.5V      | <0.5      | <1   | <1   | <1   | <1   | 1    |      |
| 1.8V      | <0.5      | <1   | <1   | <1   | <1   | <1   |      |
| 2.5V      | <0.5      | 1    | <1   | <1   | <1   | <1   |      |
| 3.3V      | <0.5      | 1    | <1   | <1   | <1   | <1   |      |

#### 7.3.2 Supports High-Speed Translation

SN74AVCH8T245 can support high data rate applications, which can be calculated from the maximum propagation delay. This is also dependent on output load. The translated signal data rate can be up to 320Mbps when both  $V_{CCA}$  and  $V_{CCB}$  are at least 1.8V.

#### 7.3.3 Partial-Power-Down Mode Operation

$I_{off}$  circuitry disables the outputs, preventing damaging current backflow through the SN74AVCH8T245 when it is powered down. Damaging current backflow can occur in applications where subsections of a system are powered down (partial-power-down) to reduce power consumption.

### 7.3.4 Bus-Hold Circuitry

Active bus-hold circuitry holds unused or undriven data inputs at a valid logic state, which helps with board space savings and reduced component costs. Use of pull-up or pull-down resistors with the bus-hold circuitry is not recommended. For more information, see [Bus-Hold Circuit](#).

### 7.3.5 V<sub>CC</sub> Isolation Feature

The V<sub>CC</sub> isolation feature allows both ports to be in a high-impedance state if either V<sub>CCA</sub> or V<sub>CCB</sub> are at GND (or < 0.4V). For more information, see I<sub>OZ</sub> in the [Electrical Characteristics](#). This feature prevents false logic levels from being presented to either bus.

## 7.4 Device Functional Modes

表 7-2 lists the functional modes of the SN74AVCH8T245.

表 7-2. Function Table (Each 8-Bit Section)

| CONTROL INPUTS <sup>(1)</sup> |     | OUTPUT CIRCUITS |         | OPERATION       |
|-------------------------------|-----|-----------------|---------|-----------------|
| OE                            | DIR | A PORT          | B PORT  |                 |
| L                             | L   | Enabled         | Hi-Z    | B data to A bus |
| L                             | H   | Hi-Z            | Enabled | A data to B bus |
| H                             | X   | Hi-Z            | Hi-Z    | Isolation       |

(1) Input circuits of the data I/Os are always active.

## 8 Application and Implementation

### 备注

以下应用部分中的信息不属于 TI 器件规格的范围，TI 不担保其准确性和完整性。TI 的客户应负责确定器件是否适用于其应用。客户应验证并测试其设计，以确保系统功能。

### 8.1 Application Information

The SN74AVCH8T245 device can be used in level-translation applications for interfacing devices or systems operating at different interface voltages with one another. The SN74AVCH8T245 device is an excellent choice for data transmission when direction is different. The maximum data rate can be up to 320Mbps when device voltage power supply is more than 1.8V.

### 8.2 Typical Application



图 8-1. Typical Application Schematic

## 8.2.1 Design Requirements

For this design example, use the parameters listed in 表 8-1.

表 8-1. Design Parameters

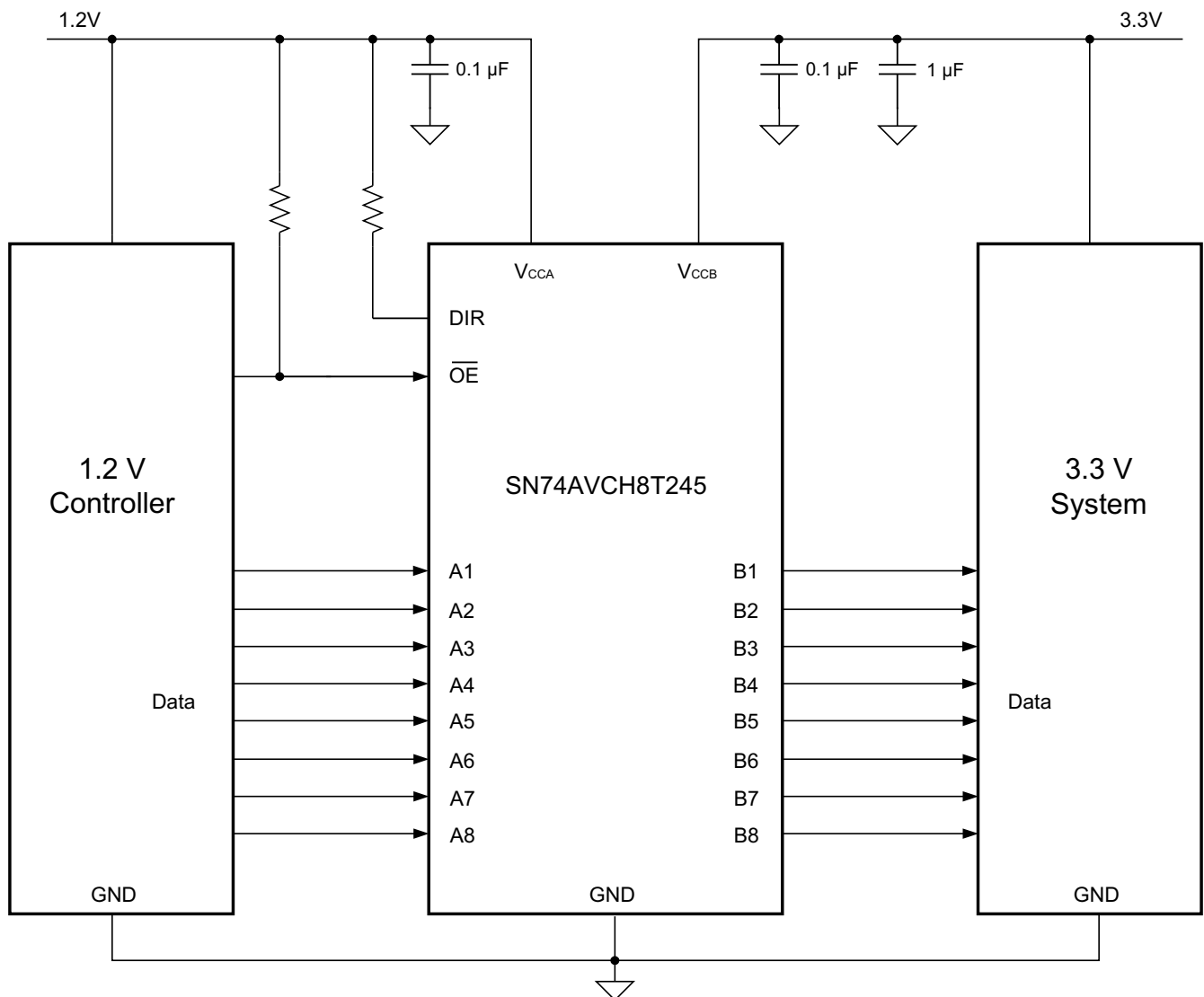
| DESIGN PARAMETERS | EXAMPLE VALUE |
|-------------------|---------------|
| Input voltage     | 1.2V to 3.6V  |
| Output voltage    | 1.2V to 3.6V  |

## 8.2.2 Detailed Design Procedure

To begin the design process, determine the following:

- Input voltage range:
  - Use the supply voltage of the device that is driving the SN74AVCH8T245 device to determine the input voltage range. For a valid logic high, the value must exceed the  $V_{IH}$  of the input port. For a valid logic low, the value must be less than the  $V_{IL}$  of the input port.
- Output voltage range:
  - Use the supply voltage of the device that the SN74AVCH8T245 device is driving to determine the output voltage range.

## 8.2.3 Application Curves



图 8-2. Translation Up (1.2V to 3.3V) at 2.5MHz

## 8.3 Power Supply Recommendations

The design of the output-enable ( $\overline{OE}$ ) input circuit is referenced to  $V_{CCA}$  so that all outputs are placed in the high-impedance state when the  $\overline{OE}$  input is high. To put the outputs in a high-impedance state during power up or power down, the  $\overline{OE}$  input pin must be tied to  $V_{CCA}$  through a pullup resistor and must not be enabled until  $V_{CCA}$  and  $V_{CCB}$  are fully ramped and stable. The current-sinking capability of the driver determines the minimum value of the pullup resistor to  $V_{CCA}$ .

$V_{CCA}$  or  $V_{CCB}$  can be powered up first. If the SN74AVCH8T245 is powered up in a permanently enabled state (for example  $\overline{OE}$  is always kept low), then pullup resistors are recommended at the input. Doing this allows for proper, glitch-free, power-up. For more information, see [Designing with SN4LVCXT245 and SN74LVCHXT245 Family of Direction Controlled Voltage Translators/Level-Shifters](#). In addition, the  $\overline{OE}$  pin may be shorted to GND if the application does not require use of the high-impedance state at any time.

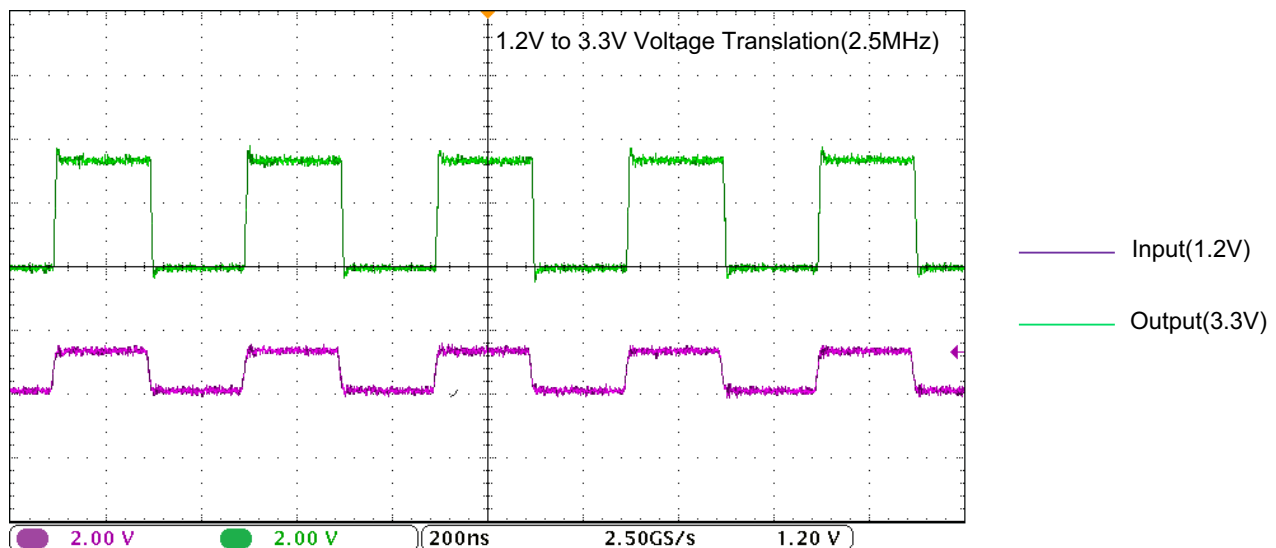
## 8.4 Layout

### 8.4.1 Layout Guidelines

For device reliability, TI recommends following the common printed-circuit board layout guidelines.

- Use bypass capacitors on power supplies.
- Use short trace lengths to avoid excessive loading.
- Placing pads on the signal paths for loading capacitors or pullup resistors to help adjust rise and fall times of signals depending on the system requirements.

### 8.4.2 Layout Example



图 8-3. SN74AVCH8T245 Layout Example

## 9 Device and Documentation Support

### 9.1 Documentation Support

#### 9.1.1 Related Documentation

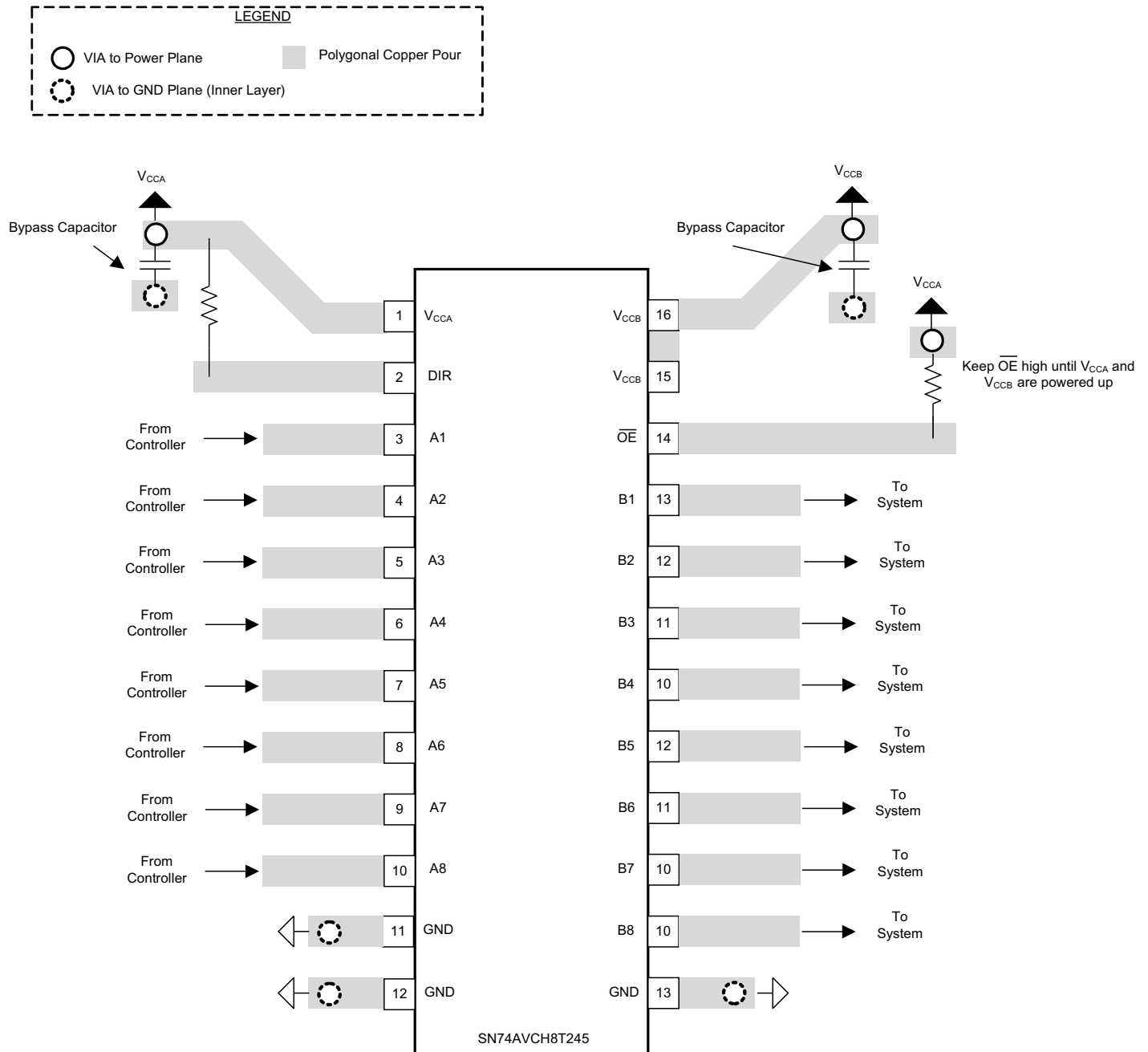
For related documentation, see the following:

- Texas Instruments, [Designing with SN74LVCXT245 and SN74LVCHXT245 Family of Direction Controlled Voltage Translators/Level-Shifters](#)
- Texas Instruments, [Bus-Hold Circuit](#)
- Texas Instruments, [AVC Logic Family Technology and Applications](#)
- Texas Instruments, [CMOS Power Consumption and Cpd Calculation](#)

#### 9.2 接收文档更新通知

要接收文档更新通知，请导航至 [ti.com](http://ti.com) 上的器件产品文件夹。点击 [通知](#) 进行注册，即可每周接收产品信息更改摘要。有关更改的详细信息，请查看任何已修订文档中包含的修订历史记录。

#### 9.3 支持资源

[TI E2E™ 中文支持论坛](#) 是工程师的重要参考资料，可直接从专家处获得快速、经过验证的解答和设计帮助。搜索现有解答或提出自己的问题，获得所需的快速设计帮助。

链接的内容由各个贡献者“按原样”提供。这些内容并不构成 TI 技术规范，并且不一定反映 TI 的观点；请参阅 TI 的 [使用条款](#)。

#### 9.4 Trademarks

TI E2E™ is a trademark of Texas Instruments.

所有商标均为其各自所有者的财产。

#### 9.5 静电放电警告



静电放电 (ESD) 会损坏这个集成电路。德州仪器 (TI) 建议通过适当的预防措施处理所有集成电路。如果不遵守正确的处理和安装程序，可能会损坏集成电路。

ESD 的损坏小至导致微小的性能降级，大至整个器件故障。精密的集成电路可能更容易受到损坏，这是因为非常细微的参数更改都可能会导致器件与其发布的规格不相符。

#### 9.6 术语表

[TI 术语表](#) 本术语表列出并解释了术语、首字母缩略词和定义。

## 10 Revision History

注：以前版本的页码可能与当前版本的页码不同

| Changes from Revision I (November 2023) to Revision J (April 2024)              | Page |
|---|------|
| • Changed kW to kΩ in the <i>Load Circuit and Voltage Waveforms</i> figure..... | 16   |

| Changes from Revision H (January 2016) to Revision I (November 2023)   | Page |
|--|------|
| • 更新了整个文档中的表格、图和交叉参考的编号格式.....   | 1    |
| • 更新了 <i>封装信息</i> 表以包含封装引线尺寸.....  | 1    |
| • Updated the <i>Thermal Information</i> table for the <i>DGV</i> , <i>PW</i> , and <i>RHL</i> packages..... | 6    |

---

| <b>Changes from Revision G (March 2007) to Revision H (January 2016)</b>        | <b>Page</b> |
|---|-------------|
| • 添加了 ESD 等级表、特性说明部分、器件功能模式、应用和实施部分、电源相关建议部分、布局部分、器件和文档支持部分以及机械、封装和可订购信息部分..... | 1           |
| • 删除了订购信息表.....   | 1           |

---

## 11 Mechanical, Packaging, and Orderable Information

The following pages include mechanical, packaging, and orderable information. This information is the most current data available for the designated devices. This data is subject to change without notice and revision of this document. For browser-based versions of this data sheet, refer to the left-hand navigation.

**PACKAGING INFORMATION**

| Orderable Device   | Status<br>(1) | Package Type | Package Drawing | Pins | Package Qty | Eco Plan<br>(2) | Lead finish/<br>Ball material<br>(6) | MSL Peak Temp<br>(3) | Op Temp (°C) | Device Marking<br>(4/5) | Samples                 |
|--------------------|---------------|--------------|-----------------|------|-------------|-----------------|--------------------------------------|----------------------|--------------|-------------------------|-------------------------|
| 74AVCH8T245PWRG4   | ACTIVE        | TSSOP        | PW              | 24   | 2000        | RoHS & Green    | NIPDAU                               | Level-1-260C-UNLIM   | -40 to 85    | WP245                   | <a href="#">Samples</a> |
| 74AVCH8T245RHRLRG4 | ACTIVE        | VQFN         | RHL             | 24   | 1000        | RoHS & Green    | NIPDAU                               | Level-2-260C-1 YEAR  | -40 to 85    | WP245                   | <a href="#">Samples</a> |
| SN74AVCH8T245DGVR  | ACTIVE        | TVSOP        | DGV             | 24   | 2000        | RoHS & Green    | NIPDAU                               | Level-1-260C-UNLIM   | -40 to 85    | WP245                   | <a href="#">Samples</a> |
| SN74AVCH8T245PW    | ACTIVE        | TSSOP        | PW              | 24   | 60          | RoHS & Green    | NIPDAU                               | Level-1-260C-UNLIM   | -40 to 85    | WP245                   | <a href="#">Samples</a> |
| SN74AVCH8T245PWG4  | ACTIVE        | TSSOP        | PW              | 24   | 60          | RoHS & Green    | NIPDAU                               | Level-1-260C-UNLIM   | -40 to 85    | WP245                   | <a href="#">Samples</a> |
| SN74AVCH8T245PWR   | ACTIVE        | TSSOP        | PW              | 24   | 2000        | RoHS & Green    | NIPDAU                               | Level-1-260C-UNLIM   | -40 to 85    | WP245                   | <a href="#">Samples</a> |
| SN74AVCH8T245RHRLR | ACTIVE        | VQFN         | RHL             | 24   | 1000        | RoHS & Green    | NIPDAU                               | Level-2-260C-1 YEAR  | -40 to 85    | WP245                   | <a href="#">Samples</a> |

(1) The marketing status values are defined as follows:

**ACTIVE:** Product device recommended for new designs.

**LIFEBUY:** TI has announced that the device will be discontinued, and a lifetime-buy period is in effect.

**NRND:** Not recommended for new designs. Device is in production to support existing customers, but TI does not recommend using this part in a new design.

**PREVIEW:** Device has been announced but is not in production. Samples may or may not be available.

**OBSOLETE:** TI has discontinued the production of the device.

(2) **RoHS:** TI defines "RoHS" to mean semiconductor products that are compliant with the current EU RoHS requirements for all 10 RoHS substances, including the requirement that RoHS substance do not exceed 0.1% by weight in homogeneous materials. Where designed to be soldered at high temperatures, "RoHS" products are suitable for use in specified lead-free processes. TI may reference these types of products as "Pb-Free".

**RoHS Exempt:** TI defines "RoHS Exempt" to mean products that contain lead but are compliant with EU RoHS pursuant to a specific EU RoHS exemption.

**Green:** TI defines "Green" to mean the content of Chlorine (Cl) and Bromine (Br) based flame retardants meet JS709B low halogen requirements of <=1000ppm threshold. Antimony trioxide based flame retardants must also meet the <=1000ppm threshold requirement.

(3) MSL, Peak Temp. - The Moisture Sensitivity Level rating according to the JEDEC industry standard classifications, and peak solder temperature.

(4) There may be additional marking, which relates to the logo, the lot trace code information, or the environmental category on the device.

(5) Multiple Device Markings will be inside parentheses. Only one Device Marking contained in parentheses and separated by a "~" will appear on a device. If a line is indented then it is a continuation of the previous line and the two combined represent the entire Device Marking for that device.



<sup>(6)</sup> Lead finish/Ball material - Orderable Devices may have multiple material finish options. Finish options are separated by a vertical ruled line. Lead finish/Ball material values may wrap to two lines if the finish value exceeds the maximum column width.

**Important Information and Disclaimer:**The information provided on this page represents TI's knowledge and belief as of the date that it is provided. TI bases its knowledge and belief on information provided by third parties, and makes no representation or warranty as to the accuracy of such information. Efforts are underway to better integrate information from third parties. TI has taken and continues to take reasonable steps to provide representative and accurate information but may not have conducted destructive testing or chemical analysis on incoming materials and chemicals. TI and TI suppliers consider certain information to be proprietary, and thus CAS numbers and other limited information may not be available for release.

In no event shall TI's liability arising out of such information exceed the total purchase price of the TI part(s) at issue in this document sold by TI to Customer on an annual basis.

**TAPE AND REEL INFORMATION**

**QUADRANT ASSIGNMENTS FOR PIN 1 ORIENTATION IN TAPE**

\*All dimensions are nominal

| Device            | Package Type | Package Drawing | Pins | SPQ  | Reel Diameter (mm) | Reel Width W1 (mm) | A0 (mm) | B0 (mm) | K0 (mm) | P1 (mm) | W (mm) | Pin1 Quadrant |
|-------------------|--------------|-----------------|------|------|--------------------|--------------------|---------|---------|---------|---------|--------|---------------|
| SN74AVCH8T245DGVR | TVSOP        | DGV             | 24   | 2000 | 330.0              | 12.4               | 6.9     | 5.6     | 1.6     | 8.0     | 12.0   | Q1            |
| SN74AVCH8T245PWR  | TSSOP        | PW              | 24   | 2000 | 330.0              | 16.4               | 6.95    | 8.3     | 1.6     | 8.0     | 16.0   | Q1            |
| SN74AVCH8T245RHLR | VQFN         | RHL             | 24   | 1000 | 180.0              | 12.4               | 3.8     | 5.8     | 1.2     | 8.0     | 12.0   | Q1            |

**TAPE AND REEL BOX DIMENSIONS**

\*All dimensions are nominal

| Device            | Package Type | Package Drawing | Pins | SPQ  | Length (mm) | Width (mm) | Height (mm) |
|-------------------|--------------|-----------------|------|------|-------------|------------|-------------|
| SN74AVCH8T245DGVR | TVSOP        | DGV             | 24   | 2000 | 356.0       | 356.0      | 35.0        |
| SN74AVCH8T245PWR  | TSSOP        | PW              | 24   | 2000 | 356.0       | 356.0      | 35.0        |
| SN74AVCH8T245RHLR | VQFN         | RHL             | 24   | 1000 | 210.0       | 185.0      | 35.0        |

**TUBE**

\*All dimensions are nominal

| Device            | Package Name | Package Type | Pins | SPQ | L (mm) | W (mm) | T (μm) | B (mm) |
|-------------------|--------------|--------------|------|-----|--------|--------|--------|--------|
| SN74AVCH8T245PW   | PW           | TSSOP        | 24   | 60  | 530    | 10.2   | 3600   | 3.5    |
| SN74AVCH8T245PWG4 | PW           | TSSOP        | 24   | 60  | 530    | 10.2   | 3600   | 3.5    |

PW0024A



# PACKAGE OUTLINE

## TSSOP - 1.2 mm max height

SMALL OUTLINE PACKAGE



4220208/A 02/2017

NOTES:

1. All linear dimensions are in millimeters. Any dimensions in parenthesis are for reference only. Dimensioning and tolerancing per ASME Y14.5M.
2. This drawing is subject to change without notice.
3. This dimension does not include mold flash, protrusions, or gate burrs. Mold flash, protrusions, or gate burrs shall not exceed 0.15 mm per side.
4. This dimension does not include interlead flash. Interlead flash shall not exceed 0.25 mm per side.
5. Reference JEDEC registration MO-153.

# EXAMPLE BOARD LAYOUT

PW0024A

TSSOP - 1.2 mm max height

SMALL OUTLINE PACKAGE



LAND PATTERN EXAMPLE  
EXPOSED METAL SHOWN  
SCALE: 10X



SOLDER MASK DETAILS

4220208/A 02/2017

NOTES: (continued)

- 6. Publication IPC-7351 may have alternate designs.
- 7. Solder mask tolerances between and around signal pads can vary based on board fabrication site.

# EXAMPLE STENCIL DESIGN

PW0024A

TSSOP - 1.2 mm max height

SMALL OUTLINE PACKAGE



NOTES: (continued)

8. Laser cutting apertures with trapezoidal walls and rounded corners may offer better paste release. IPC-7525 may have alternate design recommendations.
9. Board assembly site may have different recommendations for stencil design.

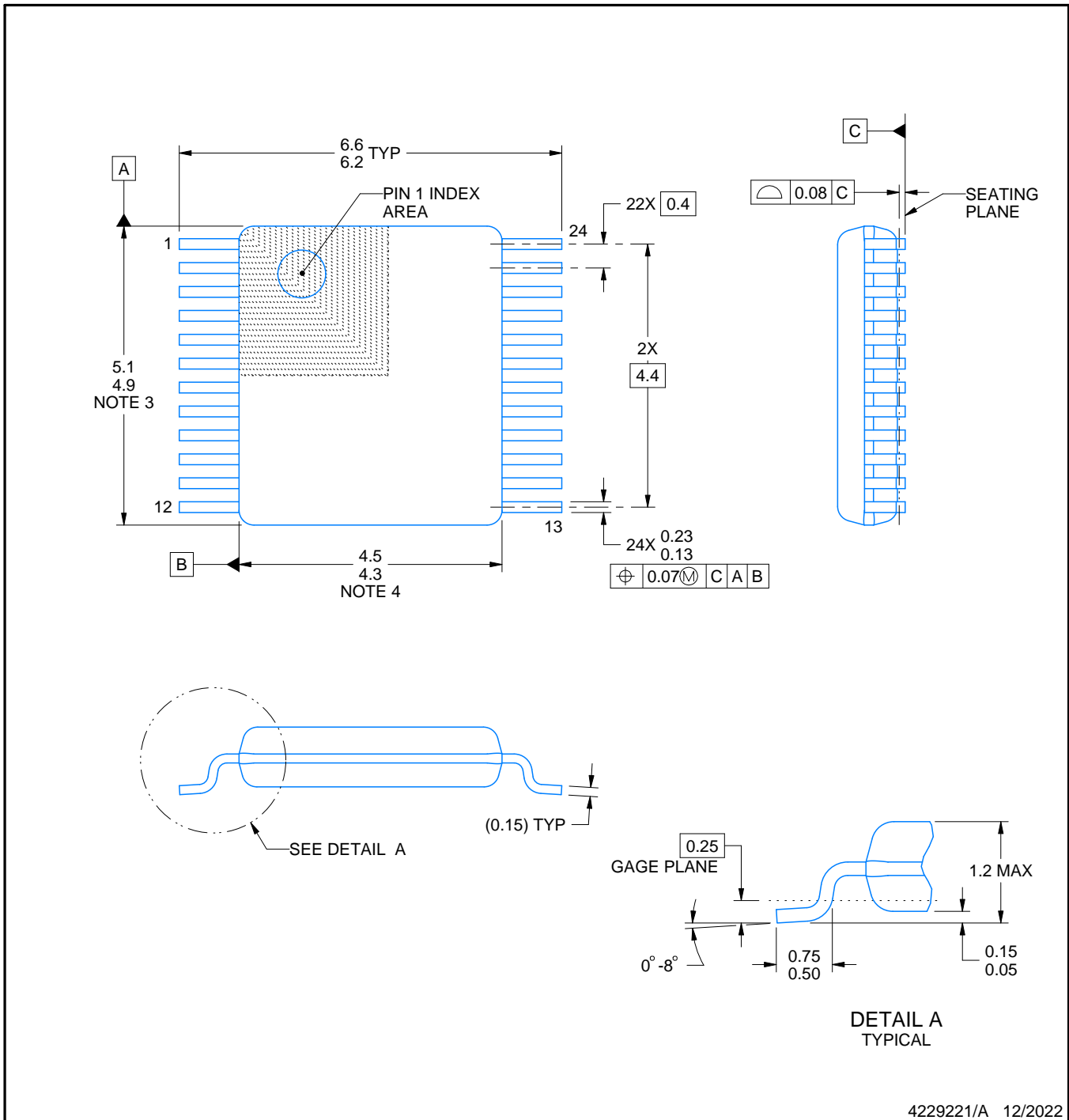
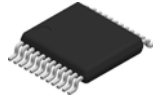

4229221/A 12/2022

NOTES:

1. All linear dimensions are in millimeters. Any dimensions in parenthesis are for reference only. Dimensioning and tolerancing per ASME Y14.5M.
2. This drawing is subject to change without notice.
3. This dimension does not include mold flash, protrusions, or gate burrs. Mold flash, protrusions, or gate burrs shall not exceed 0.15 mm per side.
4. This dimension does not include interlead flash. Interlead flash shall not exceed 0.25 mm per side.
5. Reference JEDEC registration MO-153.



# EXAMPLE BOARD LAYOUT

DGV0024A

TVSOP - 1.2 mm max height

SMALL OUTLINE PACKAGE

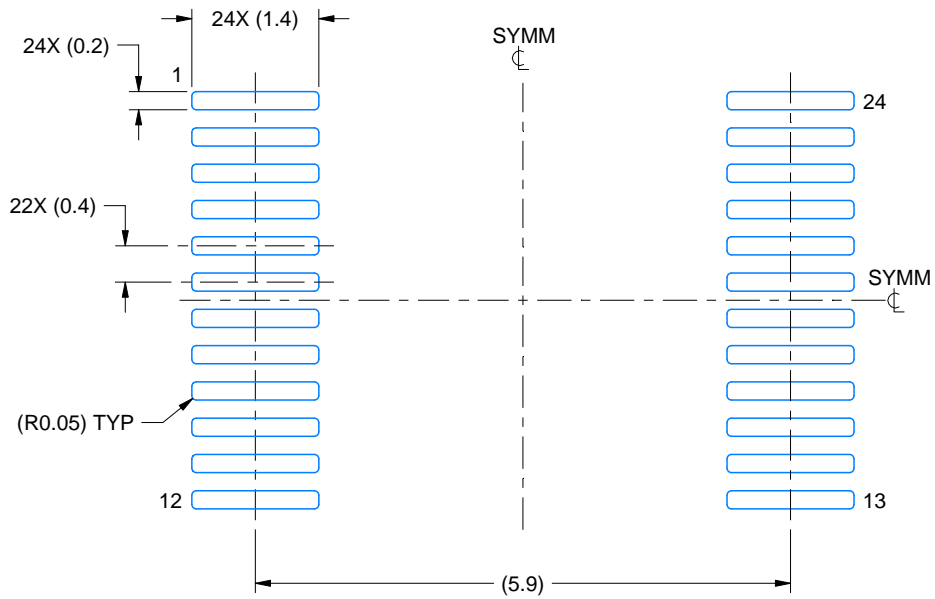

LAND PATTERN EXAMPLE  
EXPOSED METAL SHOWN  
SCALE: 12X

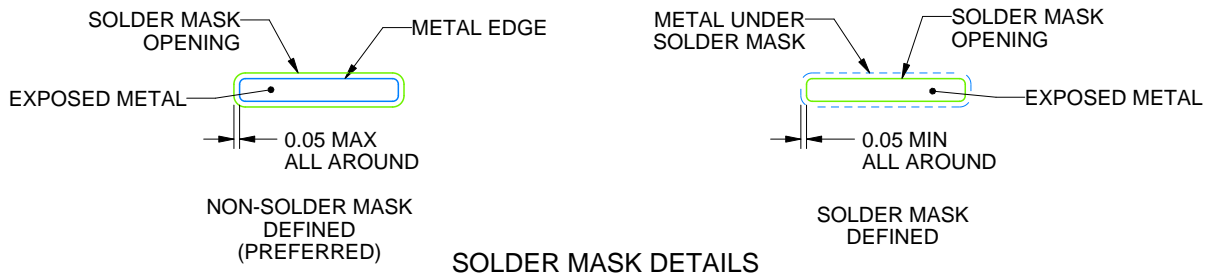

SOLDER MASK DETAILS

4229221/A 12/2022

NOTES: (continued)

- 6. Publication IPC-7351 may have alternate designs.
- 7. Solder mask tolerances between and around signal pads can vary based on board fabrication site.

# EXAMPLE STENCIL DESIGN

DGV0024A

TVSOP - 1.2 mm max height

SMALL OUTLINE PACKAGE

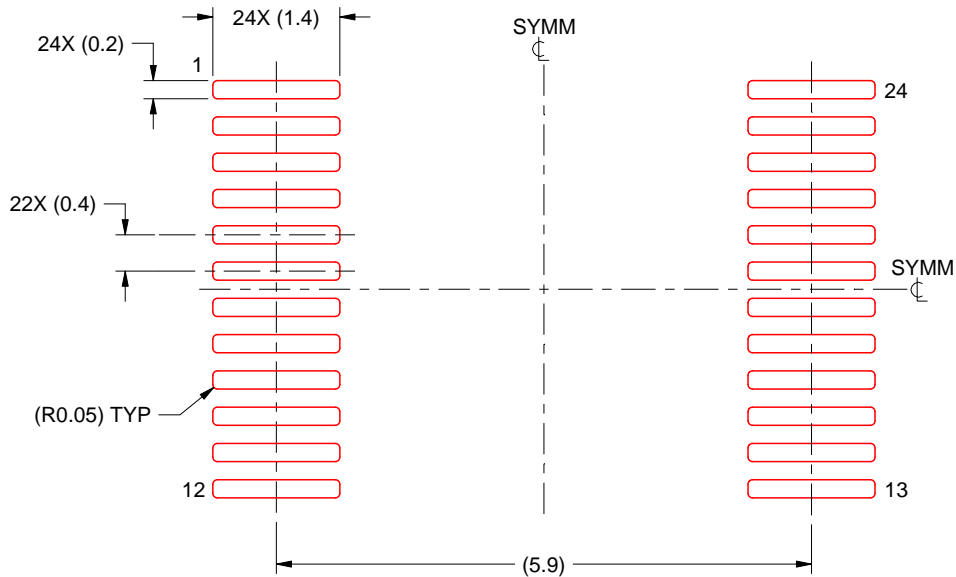

SOLDER PASTE EXAMPLE  
BASED ON 0.125 mm THICK STENCIL  
SCALE: 12X

4229221/A 12/2022

NOTES: (continued)

8. Laser cutting apertures with trapezoidal walls and rounded corners may offer better paste release. IPC-7525 may have alternate design recommendations.
9. Board assembly site may have different recommendations for stencil design.

**GENERIC PACKAGE VIEW**

**RGY 24**

**VQFN - 1 mm max height**

**5.5 x 3.5 mm, 0.5 mm pitch**

PLASTIC QUAD FLATPACK - NO LEAD

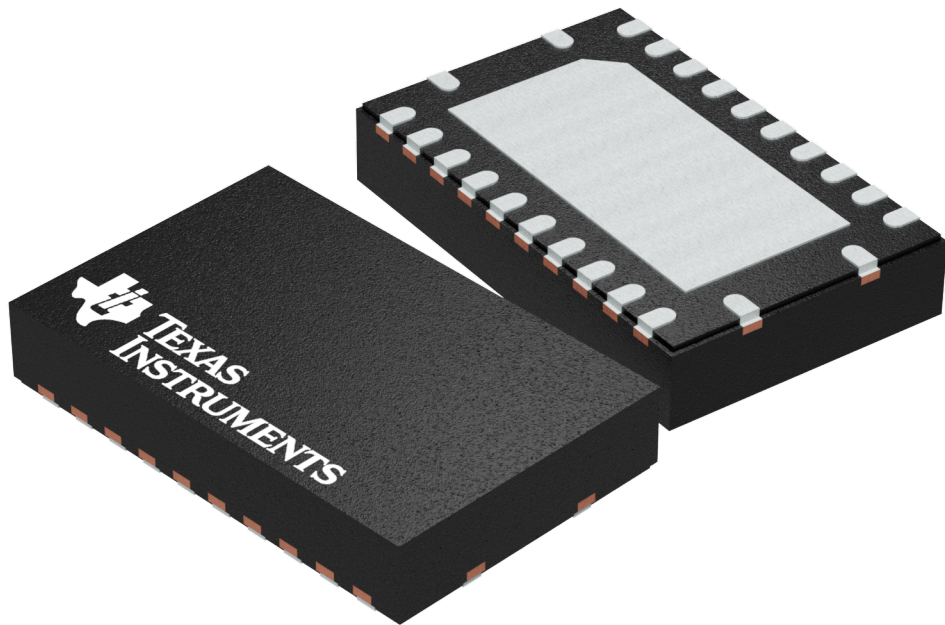

Images above are just a representation of the package family, actual package may vary.  
Refer to the product data sheet for package details.

4203539-5/J

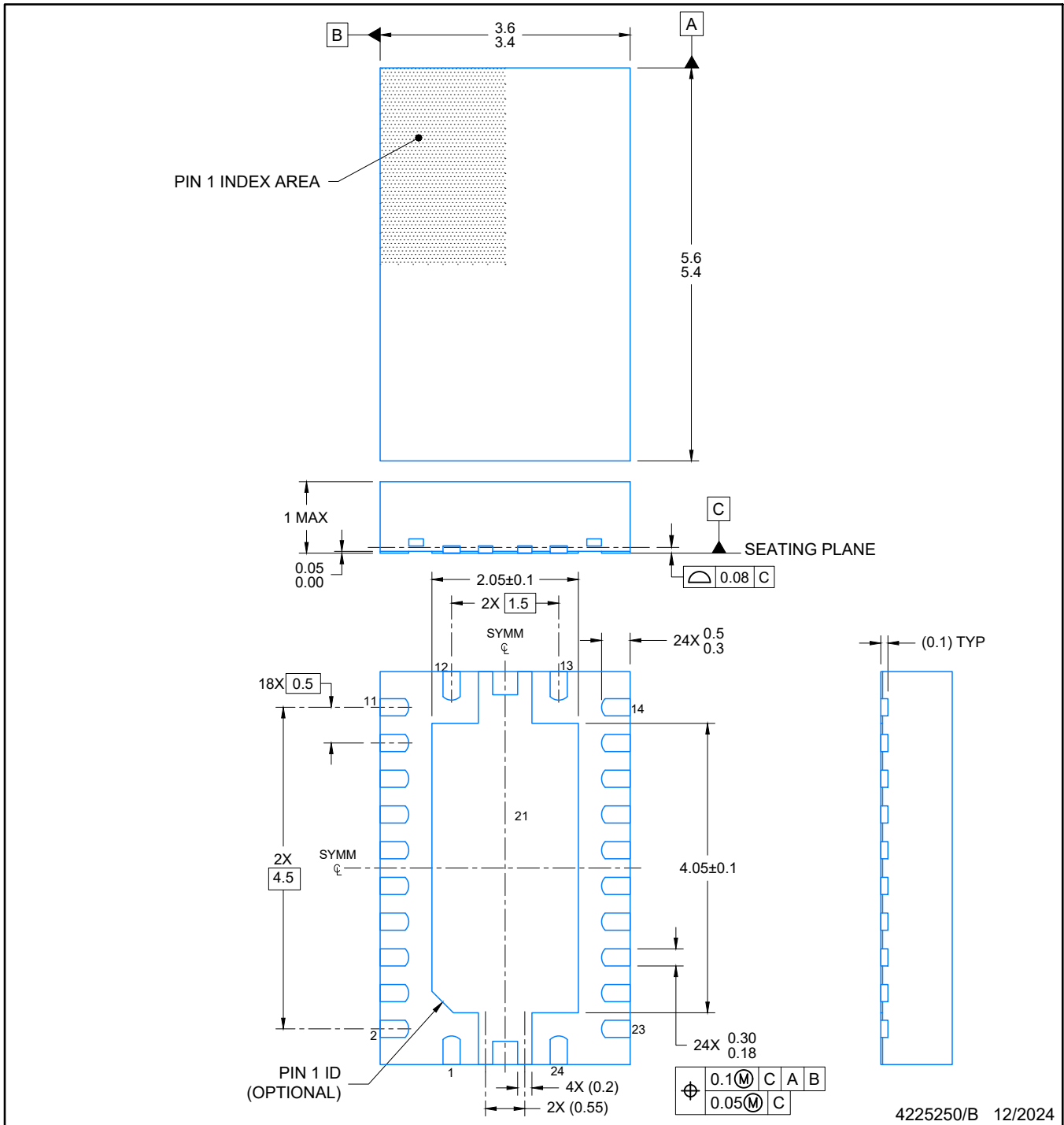

NOTES:

1. All linear dimensions are in millimeters. Any dimensions in parenthesis are for reference only. Dimensioning and tolerancing per ASME Y14.5M.
2. This drawing is subject to change without notice.
3. The package thermal pad must be soldered to the printed circuit board for optimal thermal and mechanical performance.

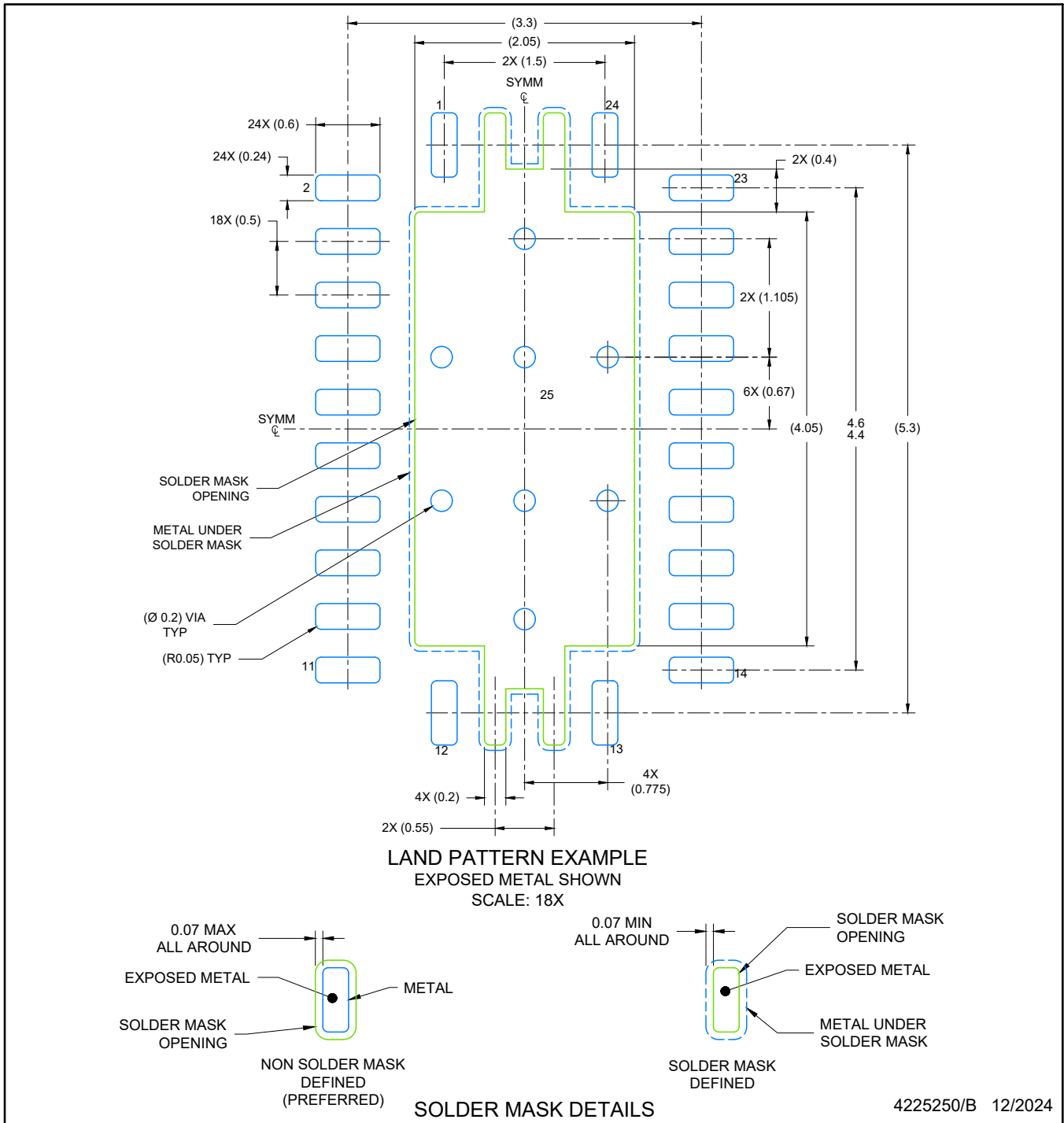

NOTES: (continued)

- This package is designed to be soldered to a thermal pad on the board. For more information, see Texas Instruments literature number SLUA271 ([www.ti.com/lit/sluea271](http://www.ti.com/lit/sluea271)).
- Vias are optional depending on application, refer to device data sheet. If any vias are implemented, refer to their locations shown on this view. It is recommended that vias under paste be filled, plugged or tented.

# EXAMPLE STENCIL DESIGN

VQFN - 1 mm max height

RHL0024A

PLASTIC QUAD FLATPACK- NO LEAD

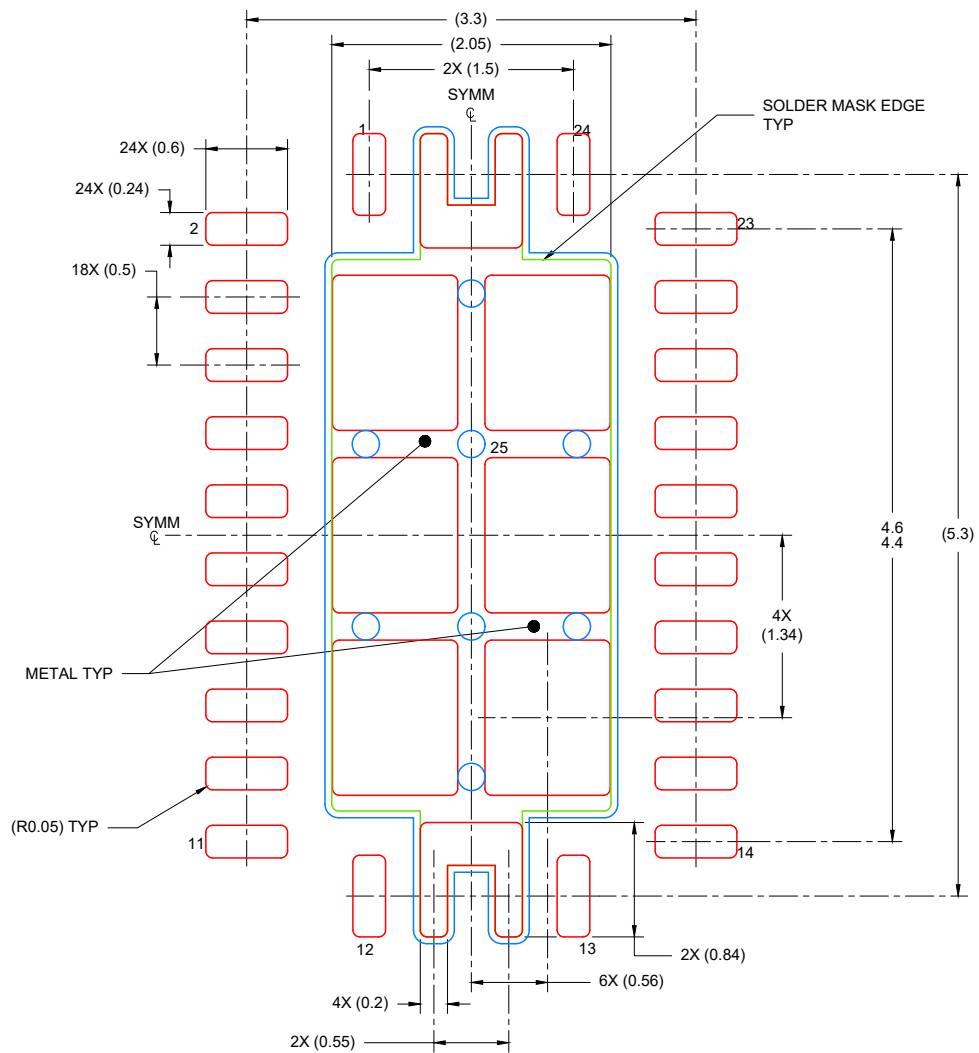

SOLDER PASTE EXAMPLE  
BASED ON 0.125 mm THICK STENCIL

EXPOSED PAD  
80% PRINTED COVERAGE BY AREA  
SCALE: 18X

4225250/B 12/2024

NOTES: (continued)

6. Laser cutting apertures with trapezoidal walls and rounded corners may offer better paste release. IPC-7525 may have alternate design recommendations.

## 重要通知和免责声明

TI“按原样”提供技术和可靠性数据（包括数据表）、设计资源（包括参考设计）、应用或其他设计建议、网络工具、安全信息和其他资源，不保证没有瑕疵且不做任何明示或暗示的担保，包括但不限于对适销性、某特定用途方面的适用性或不侵犯任何第三方知识产权的暗示担保。

这些资源可供使用 TI 产品进行设计的熟练开发人员使用。您将自行承担以下全部责任：(1) 针对您的应用选择合适的 TI 产品，(2) 设计、验证并测试您的应用，(3) 确保您的应用满足相应标准以及任何其他功能安全、信息安全、监管或其他要求。

这些资源如有变更，恕不另行通知。TI 授权您仅可将这些资源用于研发本资源所述的 TI 产品的相关应用。严禁以其他方式对这些资源进行复制或展示。您无权使用任何其他 TI 知识产权或任何第三方知识产权。您应全额赔偿因在这些资源的使用中对 TI 及其代表造成的任何索赔、损害、成本、损失和债务，TI 对此概不负责。

TI 提供的产品受 [TI 的销售条款](#) 或 [ti.com](#) 上其他适用条款/TI 产品随附的其他适用条款的约束。TI 提供这些资源并不会扩展或以其他方式更改 TI 针对 TI 产品发布的适用的担保或担保免责声明。

TI 反对并拒绝您可能提出的任何其他或不同的条款。

邮寄地址：Texas Instruments, Post Office Box 655303, Dallas, Texas 75265  
版权所有 © 2025，德州仪器 (TI) 公司