

# SN74CBT3257C

## 4-BIT 1-OF-2 FET MULTIPLEXER/DEMULTIPLEXER 5-V BUS SWITCH WITH -2-V UNDERSHOOT PROTECTION

SCDS137 – OCTOBER 2003

- Undershoot Protection for Off-Isolation on A and B Ports Up To -2 V
- Bidirectional Data Flow, With Near-Zero Propagation Delay
- Low ON-State Resistance ( $r_{ON}$ ) Characteristics ( $r_{ON} = 3 \Omega$  Typical)
- Low Input/Output Capacitance Minimizes Loading and Signal Distortion ( $C_{io(OFF)} = 5.5 \text{ pF}$  Typical)
- Data and Control Inputs Provide Undershoot Clamp Diodes
- Low Power Consumption ( $I_{CC} = 3 \mu\text{A}$  Max)
- $V_{CC}$  Operating Range From 4 V to 5.5 V
- Data I/Os Support 0 to 5-V Signaling Levels (0.8-V, 1.2-V, 1.5-V, 1.8-V, 2.5-V, 3.3-V, 5-V)
- Control Inputs Can be Driven by TTL or 5-V/3.3-V CMOS Outputs
- $I_{off}$  Supports Partial-Power-Down Mode Operation
- Latch-Up Performance Exceeds 100 mA Per JESD 78, Class II
- ESD Performance Tested Per JESD 22
  - 2000-V Human-Body Model (A114-B, Class II)
  - 1000-V Charged-Device Model (C101)
- Supports I<sup>2</sup>C Bus Expansion
- Supports Both Digital and Analog  
Applications: USB Interface, Bus Isolation, Low-Distortion Signal Gating

D, DB, DBQ, OR PW PACKAGE  
(TOP VIEW)

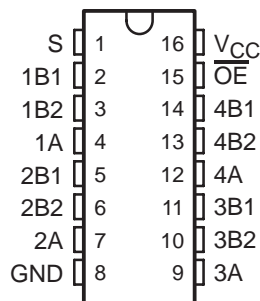

RGY PACKAGE  
(TOP VIEW)

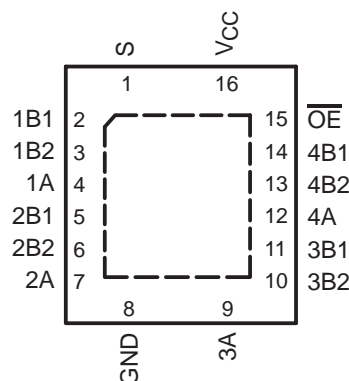

### description/ordering information

#### ORDERING INFORMATION

T <sub>A</sub>	PACKAGE†		ORDERABLE PART NUMBER	TOP-SIDE MARKING
-40°C to 85°C	QFN – RGY	Tape and reel	SN74CBT3257CRGYR	CU257C
	SOIC – D	Tube	SN74CBT3257CD	CBT3257C
		Tape and reel	SN74CBT3257CDR	
	SSOP – DB	Tape and reel	SN74CBT3257CDBR	CU257C
	SSOP (QSOP) – DBQ	Tape and reel	SN74CBT3257CDBQR	CU257C
	TSSOP – PW	Tube	SN74CBT3257CPW	CU257C
Tape and reel		SN74CBT3257CPWR		

† Package drawings, standard packing quantities, thermal data, symbolization, and PCB design guidelines are available at [www.ti.com/sc/package](http://www.ti.com/sc/package).



Please be aware that an important notice concerning availability, standard warranty, and use in critical applications of Texas Instruments semiconductor products and disclaimers thereto appears at the end of this data sheet.

PRODUCTION DATA information is current as of publication date. Products conform to specifications per the terms of Texas Instruments standard warranty. Production processing does not necessarily include testing of all parameters.



POST OFFICE BOX 655303 • DALLAS, TEXAS 75265

Copyright © 2003, Texas Instruments Incorporated

# SN74CBT3257C

## 4-BIT 1-OF-2 FET MULTIPLEXER/DEMULTIPLEXER

### 5-V BUS SWITCH WITH -2-V UNDERSHOOT PROTECTION

SCDS137 – OCTOBER 2003

#### description/ordering information (continued)

The SN74CBT3257C is a high-speed TTL-compatible FET multiplexer/demultiplexer with low ON-state resistance ( $r_{ON}$ ), allowing for minimal propagation delay. Active Undershoot-Protection Circuitry on the A and B ports of the SN74CBT3257C provides protection for undershoot up to  $-2\text{ V}$  by sensing an undershoot event and ensuring that the switch remains in the proper OFF state.

The SN74CBT3257C is a 4-bit 1-of-2 multiplexer/demultiplexer with a single output-enable ( $\overline{OE}$ ) input. The select (S) input controls the data path of the multiplexer/demultiplexer. When  $\overline{OE}$  is low, the multiplexer/demultiplexer is enabled and the A port is connected to the B port, allowing bidirectional data flow between ports. When  $\overline{OE}$  is high, the multiplexer/demultiplexer is disabled and a high-impedance state exists between the A and B ports.

This device is fully specified for partial-power-down applications using  $I_{OFF}$ . The  $I_{OFF}$  feature ensures that damaging current will not backflow through the device when it is powered down. The device has isolation during power off.

To ensure the high-impedance state during power up or power down,  $\overline{OE}$  should be tied to  $V_{CC}$  through a pullup resistor; the minimum value of the resistor is determined by the current-sinking capability of the driver.

FUNCTION TABLE

INPUTS		INPUT/OUTPUT A	FUNCTION
$\overline{OE}$	S1		
L	L	B1	A port = B1 port
L	H	B2	A port = B2 port
H	X	Z	Disconnect



**SN74CBT3257C**  
**4-BIT 1-OF-2 FET MULTIPLEXER/DEMULTIPLEXER**  
**5-V BUS SWITCH WITH -2-V UNDERSHOOT PROTECTION**

SCDS137 – OCTOBER 2003

logic diagram (positive logic)

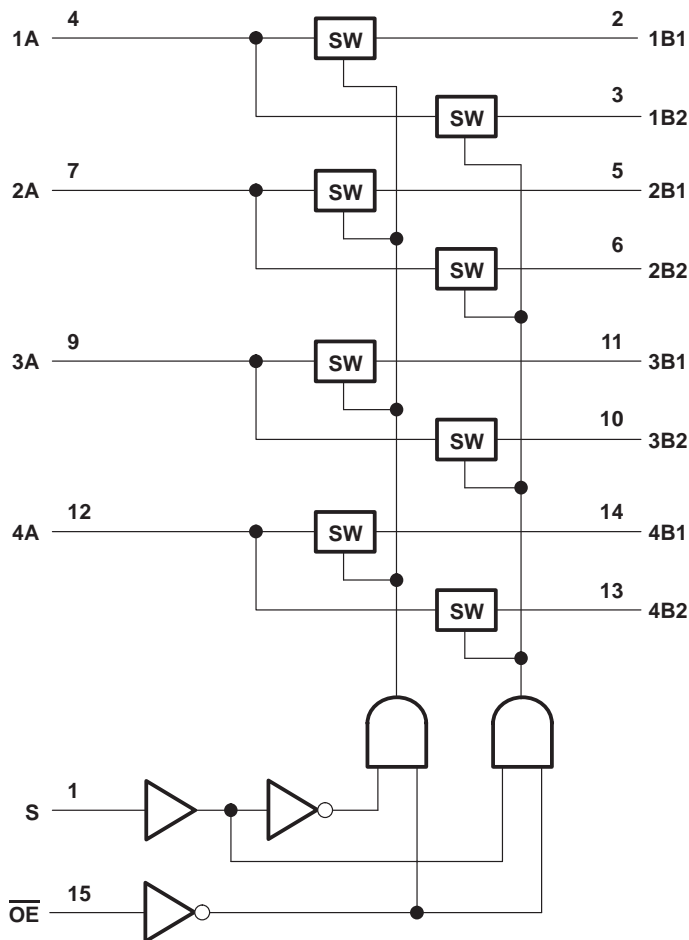

simplified schematic, each FET switch (SW)

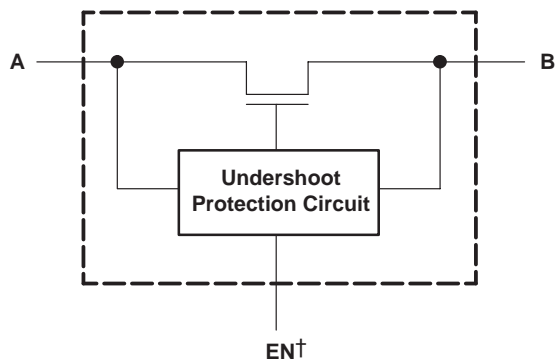

† EN is the internal enable signal applied to the switch.

**SN74CBT3257C**  
**4-BIT 1-OF-2 FET MULTIPLEXER/DEMULTIPLEXER**  
**5-V BUS SWITCH WITH -2-V UNDERSHOOT PROTECTION**

SCDS137 – OCTOBER 2003

**absolute maximum ratings over operating free-air temperature range (unless otherwise noted)†**

Supply voltage range, $V_{CC}$ .....	-0.5 V to 7 V
Control input voltage range, $V_{IN}$ (see Notes 1 and 2) .....	-0.5 V to 7 V
Switch I/O voltage range, $V_{I/O}$ (see Notes 1, 2, and 3) .....	-0.5 V to 7 V
Control input clamp current, $I_{IK}$ ( $V_{IN} < 0$ ) .....	-50 mA
I/O port clamp current, $I_{I/OK}$ ( $V_{I/O} < 0$ ) .....	-50 mA
ON-state switch current, $I_{I/O}$ (see Note 4) .....	$\pm 128$ mA
Continuous current through $V_{CC}$ or GND terminals .....	$\pm 100$ mA
Package thermal impedance, $\theta_{JA}$ (see Note 5): D package .....	73°C/W
(see Note 5): DB package .....	82°C/W
(see Note 5): DBQ package .....	90°C/W
(see Note 5): PW package .....	108°C/W
(see Note 6): RGY package .....	39°C/W
Storage temperature range, $T_{stg}$ .....	-65°C to 150°C

† Stresses beyond those listed under “absolute maximum ratings” may cause permanent damage to the device. These are stress ratings only, and functional operation of the device at these or any other conditions beyond those indicated under “recommended operating conditions” is not implied. Exposure to absolute-maximum-rated conditions for extended periods may affect device reliability.

- NOTES: 1. All voltages are with respect to ground unless otherwise specified.  
2. The input and output voltage ratings may be exceeded if the input and output clamp-current ratings are observed.  
3.  $V_I$  and  $V_O$  are used to denote specific conditions for  $V_{I/O}$ .  
4.  $I_I$  and  $I_O$  are used to denote specific conditions for  $I_{I/O}$ .  
5. The package thermal impedance is calculated in accordance with JESD 51-7.  
6. The package thermal impedance is calculated in accordance with JESD 51-5.

**recommended operating conditions (see Note 7)**

	MIN	MAX	UNIT
$V_{CC}$ Supply voltage	4	5.5	V
$V_{IH}$ High-level control input voltage	2	5.5	V
$V_{IL}$ Low-level control input voltage	0	0.8	V
$V_{I/O}$ Data input/output voltage	0	5.5	V
$T_A$ Operating free-air temperature	-40	85	°C

NOTE 7: All unused control inputs of the device must be held at  $V_{CC}$  or GND to ensure proper device operation. Refer to the TI application report, *Implications of Slow or Floating CMOS Inputs*, literature number SCBA004.



**SN74CBT3257C**  
**4-BIT 1-OF-2 FET MULTIPLEXER/DEMULTIPLEXER**  
**5-V BUS SWITCH WITH -2-V UNDERSHOOT PROTECTION**

SCDS137 – OCTOBER 2003

**electrical characteristics over recommended operating free-air temperature range (unless otherwise noted)**

PARAMETER		TEST CONDITIONS		MIN	TYP†	MAX	UNIT		
$V_{IK}$	Control inputs	$V_{CC} = 4.5\text{ V}$ ,	$I_{IN} = -18\text{ mA}$			-1.8	V		
$V_{IKU}$	Data inputs	$V_{CC} = 5\text{ V}$ ,	$0\text{ mA} > I_I \geq -50\text{ mA}$ , $V_{IN} = V_{CC}$ or GND, Switch OFF			-2	V		
$I_{IN}$	Control inputs	$V_{CC} = 5.5\text{ V}$ ,	$V_{IN} = V_{CC}$ or GND			$\pm 1$	$\mu\text{A}$		
$I_{OZ}^\ddagger$		$V_{CC} = 5.5\text{ V}$ ,	$V_O = 0$ to $5.5\text{ V}$ , $V_I = 0$ , Switch OFF, $V_{IN} = V_{CC}$ or GND			$\pm 10$	$\mu\text{A}$		
$I_{off}$		$V_{CC} = 0$ ,	$V_O = 0$ to $5.5\text{ V}$ , $V_I = 0$			10	$\mu\text{A}$		
$I_{CC}$		$V_{CC} = 5.5\text{ V}$ ,	$I_{I/O} = 0$ , $V_{IN} = V_{CC}$ or GND, Switch ON or OFF			3	$\mu\text{A}$		
$\Delta I_{CC}^\S$	Control inputs	$V_{CC} = 5.5\text{ V}$ ,	One input at $3.4\text{ V}$ , Other inputs at $V_{CC}$ or GND			2.5	mA		
$C_{in}$	Control inputs	$V_{IN} = 3\text{ V}$ or 0				3.5	pF		
$C_{io(OFF)}$	A port	$V_{I/O} = 3\text{ V}$ or 0, Switch OFF, $V_{IN} = V_{CC}$ or GND				8.5	pF		
	B port					5.5	pF		
$C_{io(ON)}$		$V_{I/O} = 3\text{ V}$ or 0, Switch ON, $V_{IN} = V_{CC}$ or GND				16.5	pF		
$r_{on}^\parallel$		$V_{CC} = 4\text{ V}$ , TYP at $V_{CC} = 4\text{ V}$	$V_I = 2.4\text{ V}$ , $I_O = -15\text{ mA}$			8	12	$\Omega$	
		$V_{CC} = 4.5\text{ V}$	$V_I = 0$			3	6		
				$I_O = 64\text{ mA}$			3		6
				$I_O = 30\text{ mA}$			3		6
		$V_I = 2.4\text{ V}$ , $I_O = -15\text{ mA}$				5	10		

$V_{IN}$  and  $I_{IN}$  refer to control inputs.  $V_I$ ,  $V_O$ ,  $I_I$ , and  $I_O$  refer to data pins.

† All typical values are at  $V_{CC} = 5\text{ V}$  (unless otherwise noted),  $T_A = 25^\circ\text{C}$ .

‡ For I/O ports, the parameter  $I_{OZ}$  includes the input leakage current.

§ This is the increase in supply current for each input that is at the specified voltage level, rather than  $V_{CC}$  or GND.

¶ Measured by the voltage drop between the A and B terminals at the indicated current through the switch. ON-state resistance is determined by the lower of the voltages of the two (A or B) terminals.

**switching characteristics over recommended operating free-air temperature range,  $C_L = 50\text{ pF}$  (unless otherwise noted) (see Figure 3)**

PARAMETER	FROM (INPUT)	TO (OUTPUT)	$V_{CC} = 4\text{ V}$		$V_{CC} = 5\text{ V} \pm 0.5\text{ V}$		UNIT
			MIN	MAX	MIN	MAX	
$t_{pd}^\#$	A or B	B or A		0.24		0.15	ns
$t_{pd(s)}$	S	A		6	1.5	5.6	ns
$t_{en}$	S	B		6.3	1.5	5.8	ns
	$\overline{OE}$	A or B		6.3	1.5	5.8	
$t_{dis}$	S	B		6.5	1.5	6	ns
	$\overline{OE}$	A or B		5.9	1.5	5.9	

# The propagation delay is the calculated RC time constant of the typical ON-state resistance of the switch and the specified load capacitance, when driven by an ideal voltage source (zero output impedance).

**SN74CBT3257C**  
**4-BIT 1-OF-2 FET MULTIPLEXER/DEMULTIPLEXER**  
**5-V BUS SWITCH WITH -2-V UNDERSHOOT PROTECTION**

SCDS137 – OCTOBER 2003

**undershoot characteristics (see Figures 1 and 2)**

PARAMETER	TEST CONDITIONS	MIN	TYP†	MAX	UNIT
$V_{OUTU}$	$V_{CC} = 5.5\text{ V}$ , Switch OFF, $V_{IN} = V_{CC}$ or GND	2	$V_{OH} - 0.3$		V

† All typical values are at  $V_{CC} = 5\text{ V}$  (unless otherwise noted),  $T_A = 25^\circ\text{C}$ .

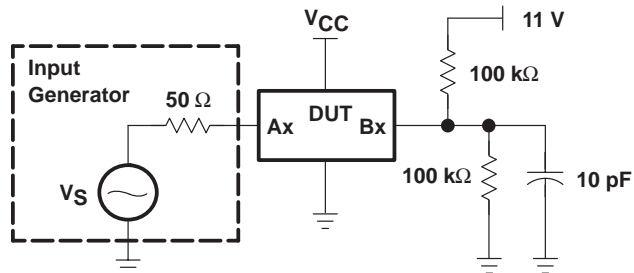

**Figure 1. Device Test Setup**

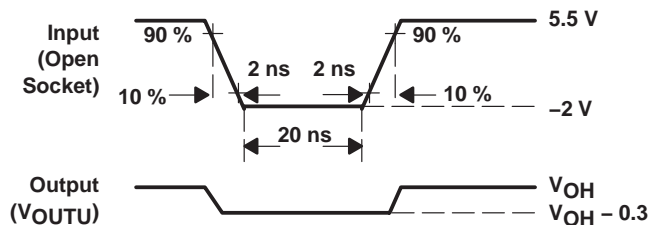
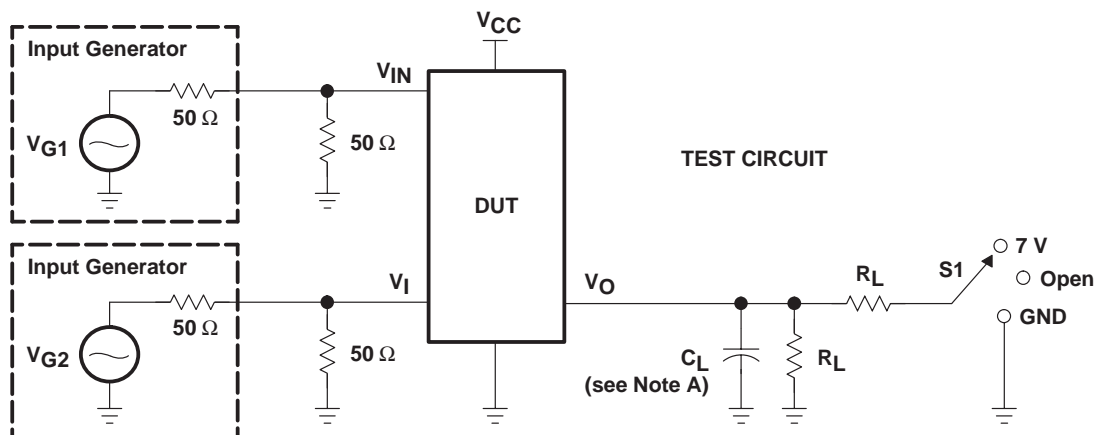

**Figure 2. Transient Input Voltage ( $V_i$ ) and Output Voltage ( $V_{OUTU}$ ) Waveforms (Switch OFF)**

**SN74CBT3257C**  
**4-BIT 1-OF-2 FET MULTIPLEXER/DEMULTIPLEXER**  
**5-V BUS SWITCH WITH -2-V UNDERSHOOT PROTECTION**

SCDS137 – OCTOBER 2003

**PARAMETER MEASUREMENT INFORMATION**



TEST	V <sub>CC</sub>	S1	R <sub>L</sub>	V <sub>I</sub>	C <sub>L</sub>	V <sub>Δ</sub>
t <sub>pd</sub> (s)	5 V ± 0.5 V	Open	500 Ω	V <sub>CC</sub> or GND	50 pF	
	4 V	Open	500 Ω	V <sub>CC</sub> or GND	50 pF	
t <sub>PLZ</sub> /t <sub>PZL</sub>	5 V ± 0.5 V	7 V	500 Ω	GND	50 pF	0.3 V
	4 V	7 V	500 Ω	GND	50 pF	0.3 V
t <sub>PHZ</sub> /t <sub>PZH</sub>	5 V ± 0.5 V	Open	500 Ω	V <sub>CC</sub>	50 pF	0.3 V
	4 V	Open	500 Ω	V <sub>CC</sub>	50 pF	0.3 V

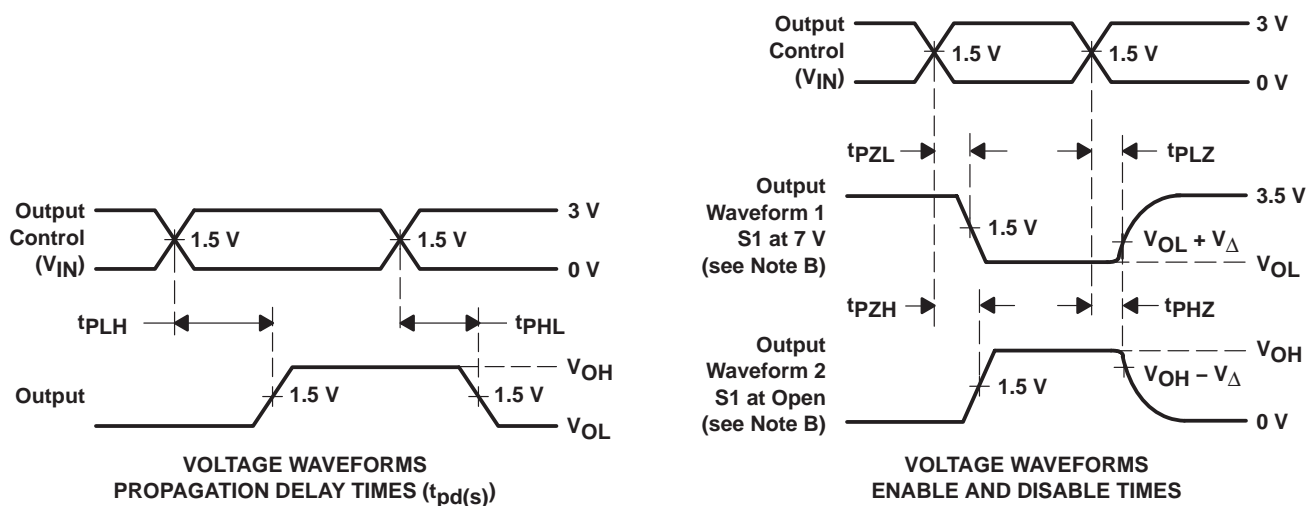

- NOTES:
- A. C<sub>L</sub> includes probe and jig capacitance.
  - B. Waveform 1 is for an output with internal conditions such that the output is low except when disabled by the output control. Waveform 2 is for an output with internal conditions such that the output is high except when disabled by the output control.
  - C. All input pulses are supplied by generators having the following characteristics: PRR ≤ 10 MHz, Z<sub>O</sub> = 50 Ω, t<sub>r</sub> ≤ 2.5 ns, t<sub>f</sub> ≤ 2.5 ns.
  - D. The outputs are measured one at a time with one transition per measurement.
  - E. t<sub>PLZ</sub> and t<sub>PHZ</sub> are the same as t<sub>dis</sub>.
  - F. t<sub>PZL</sub> and t<sub>PZH</sub> are the same as t<sub>en</sub>.
  - G. t<sub>PLH</sub> and t<sub>PHL</sub> are the same as t<sub>pd</sub>(s). The t<sub>pd</sub> propagation delay is the calculated RC time constant of the typical ON-state resistance of the switch and the specified load capacitance, when driven by an ideal voltage source (zero output impedance).
  - H. All parameters and waveforms are not applicable to all devices.

**Figure 3. Test Circuit and Voltage Waveforms**

**PACKAGING INFORMATION**

Orderable part number	Status (1)	Material type (2)	Package   Pins	Package qty   Carrier	RoHS (3)	Lead finish/ Ball material (4)	MSL rating/ Peak reflow (5)	Op temp (°C)	Part marking (6)
<a href="#">SN74CBT3257CD</a>	Active	Production	SOIC (D)   16	40   TUBE	Yes	NIPDAU	Level-1-260C-UNLIM	-40 to 85	CBT3257C
SN74CBT3257CD.B	Active	Production	SOIC (D)   16	40   TUBE	Yes	NIPDAU	Level-1-260C-UNLIM	-40 to 85	CBT3257C
<a href="#">SN74CBT3257CDBQR</a>	Active	Production	SSOP (DBQ)   16	2500   LARGE T&R	Yes	NIPDAU	Level-2-260C-1 YEAR	-40 to 85	CU257C
SN74CBT3257CDBQR.B	Active	Production	SSOP (DBQ)   16	2500   LARGE T&R	Yes	NIPDAU	Level-2-260C-1 YEAR	-40 to 85	CU257C
SN74CBT3257CDBQRG4	Active	Production	SSOP (DBQ)   16	2500   LARGE T&R	Yes	NIPDAU	Level-2-260C-1 YEAR	-40 to 85	CU257C
SN74CBT3257CDBQRG4.B	Active	Production	SSOP (DBQ)   16	2500   LARGE T&R	Yes	NIPDAU	Level-2-260C-1 YEAR	-40 to 85	CU257C
<a href="#">SN74CBT3257CDBR</a>	Active	Production	SSOP (DB)   16	2000   LARGE T&R	Yes	NIPDAU	Level-1-260C-UNLIM	-40 to 85	CU257C
SN74CBT3257CDBR.B	Active	Production	SSOP (DB)   16	2000   LARGE T&R	Yes	NIPDAU	Level-1-260C-UNLIM	-40 to 85	CU257C
<a href="#">SN74CBT3257CDR</a>	Active	Production	SOIC (D)   16	2500   LARGE T&R	Yes	NIPDAU	Level-1-260C-UNLIM	-40 to 85	CBT3257C
SN74CBT3257CDR.B	Active	Production	SOIC (D)   16	2500   LARGE T&R	Yes	NIPDAU	Level-1-260C-UNLIM	-40 to 85	CBT3257C
SN74CBT3257CDRG4	Active	Production	SOIC (D)   16	2500   LARGE T&R	Yes	NIPDAU	Level-1-260C-UNLIM	-40 to 85	CBT3257C
<a href="#">SN74CBT3257CPW</a>	Active	Production	TSSOP (PW)   16	90   TUBE	Yes	NIPDAU	Level-1-260C-UNLIM	-40 to 85	CU257C
SN74CBT3257CPW.B	Active	Production	TSSOP (PW)   16	90   TUBE	Yes	NIPDAU	Level-1-260C-UNLIM	-40 to 85	CU257C
<a href="#">SN74CBT3257CPWR</a>	Active	Production	TSSOP (PW)   16	2000   LARGE T&R	Yes	NIPDAU   SN	Level-1-260C-UNLIM	-40 to 85	CU257C
SN74CBT3257CPWR.B	Active	Production	TSSOP (PW)   16	2000   LARGE T&R	Yes	NIPDAU	Level-1-260C-UNLIM	-40 to 85	CU257C
SN74CBT3257CPWRE4	Active	Production	TSSOP (PW)   16	2000   LARGE T&R	Yes	NIPDAU	Level-1-260C-UNLIM	-40 to 85	CU257C
<a href="#">SN74CBT3257CPWRG4</a>	Active	Production	TSSOP (PW)   16	2000   LARGE T&R	Yes	NIPDAU	Level-1-260C-UNLIM	-40 to 85	CU257C
SN74CBT3257CPWRG4.B	Active	Production	TSSOP (PW)   16	2000   LARGE T&R	Yes	NIPDAU	Level-1-260C-UNLIM	-40 to 85	CU257C
<a href="#">SN74CBT3257CRGYR</a>	Active	Production	VQFN (RGY)   16	3000   LARGE T&R	Yes	NIPDAU	Level-2-260C-1 YEAR	-40 to 85	CU257C
SN74CBT3257CRGYR.B	Active	Production	VQFN (RGY)   16	3000   LARGE T&R	Yes	NIPDAU	Level-2-260C-1 YEAR	-40 to 85	CU257C
SN74CBT3257CRGYRG4	Active	Production	VQFN (RGY)   16	3000   LARGE T&R	Yes	NIPDAU	Level-2-260C-1 YEAR	-40 to 85	CU257C
SN74CBT3257CRGYRG4.B	Active	Production	VQFN (RGY)   16	3000   LARGE T&R	Yes	NIPDAU	Level-2-260C-1 YEAR	-40 to 85	CU257C

(1) **Status:** For more details on status, see our [product life cycle](#).

(2) **Material type:** When designated, preproduction parts are prototypes/experimental devices, and are not yet approved or released for full production. Testing and final process, including without limitation quality assurance, reliability performance testing, and/or process qualification, may not yet be complete, and this item is subject to further changes or possible discontinuation. If available for ordering, purchases will be subject to an additional waiver at checkout, and are intended for early internal evaluation purposes only. These items are sold without warranties of any kind.

(3) **RoHS values:** Yes, No, RoHS Exempt. See the [TI RoHS Statement](#) for additional information and value definition.

(4) **Lead finish/Ball material:** Parts may have multiple material finish options. Finish options are separated by a vertical ruled line. Lead finish/Ball material values may wrap to two lines if the finish value exceeds the maximum column width.

(5) **MSL rating/Peak reflow:** The moisture sensitivity level ratings and peak solder (reflow) temperatures. In the event that a part has multiple moisture sensitivity ratings, only the lowest level per JEDEC standards is shown. Refer to the shipping label for the actual reflow temperature that will be used to mount the part to the printed circuit board.

(6) **Part marking:** There may be an additional marking, which relates to the logo, the lot trace code information, or the environmental category of the part.

Multiple part markings will be inside parentheses. Only one part marking contained in parentheses and separated by a "~" will appear on a part. If a line is indented then it is a continuation of the previous line and the two combined represent the entire part marking for that device.

**Important Information and Disclaimer:** The information provided on this page represents TI's knowledge and belief as of the date that it is provided. TI bases its knowledge and belief on information provided by third parties, and makes no representation or warranty as to the accuracy of such information. Efforts are underway to better integrate information from third parties. TI has taken and continues to take reasonable steps to provide representative and accurate information but may not have conducted destructive testing or chemical analysis on incoming materials and chemicals. TI and TI suppliers consider certain information to be proprietary, and thus CAS numbers and other limited information may not be available for release.

In no event shall TI's liability arising out of such information exceed the total purchase price of the TI part(s) at issue in this document sold by TI to Customer on an annual basis.

**TAPE AND REEL INFORMATION**

**QUADRANT ASSIGNMENTS FOR PIN 1 ORIENTATION IN TAPE**

\*All dimensions are nominal

Device	Package Type	Package Drawing	Pins	SPQ	Reel Diameter (mm)	Reel Width W1 (mm)	A0 (mm)	B0 (mm)	K0 (mm)	P1 (mm)	W (mm)	Pin1 Quadrant
SN74CBT3257CDBQR	SSOP	DBQ	16	2500	330.0	12.5	6.4	5.2	2.1	8.0	12.0	Q1
SN74CBT3257CDBQRG4	SSOP	DBQ	16	2500	330.0	12.5	6.4	5.2	2.1	8.0	12.0	Q1
SN74CBT3257CDBR	SSOP	DB	16	2000	330.0	16.4	8.35	6.6	2.4	12.0	16.0	Q1
SN74CBT3257CDR	SOIC	D	16	2500	330.0	16.4	6.5	10.3	2.1	8.0	16.0	Q1
SN74CBT3257CPWR	TSSOP	PW	16	2000	330.0	12.4	6.9	5.6	1.6	8.0	12.0	Q1
SN74CBT3257CPWR	TSSOP	PW	16	2000	330.0	12.4	6.9	5.6	1.6	8.0	12.0	Q1
SN74CBT3257CPWRG4	TSSOP	PW	16	2000	330.0	12.4	6.9	5.6	1.6	8.0	12.0	Q1
SN74CBT3257CRGYR	VQFN	RGY	16	3000	330.0	12.4	3.8	4.3	1.5	8.0	12.0	Q1
SN74CBT3257CRGYRG4	VQFN	RGY	16	3000	330.0	12.4	3.8	4.3	1.5	8.0	12.0	Q1

**TAPE AND REEL BOX DIMENSIONS**



\*All dimensions are nominal

Device	Package Type	Package Drawing	Pins	SPQ	Length (mm)	Width (mm)	Height (mm)
SN74CBT3257CDBQR	SSOP	DBQ	16	2500	340.5	338.1	20.6
SN74CBT3257CDBQRG4	SSOP	DBQ	16	2500	340.5	338.1	20.6
SN74CBT3257CDBR	SSOP	DB	16	2000	367.0	367.0	38.0
SN74CBT3257CDR	SOIC	D	16	2500	353.0	353.0	32.0
SN74CBT3257CPWR	TSSOP	PW	16	2000	356.0	356.0	35.0
SN74CBT3257CPWR	TSSOP	PW	16	2000	353.0	353.0	32.0
SN74CBT3257CPWRG4	TSSOP	PW	16	2000	353.0	353.0	32.0
SN74CBT3257CRGYR	VQFN	RGY	16	3000	353.0	353.0	32.0
SN74CBT3257CRGYRG4	VQFN	RGY	16	3000	353.0	353.0	32.0

**TUBE**

\*All dimensions are nominal

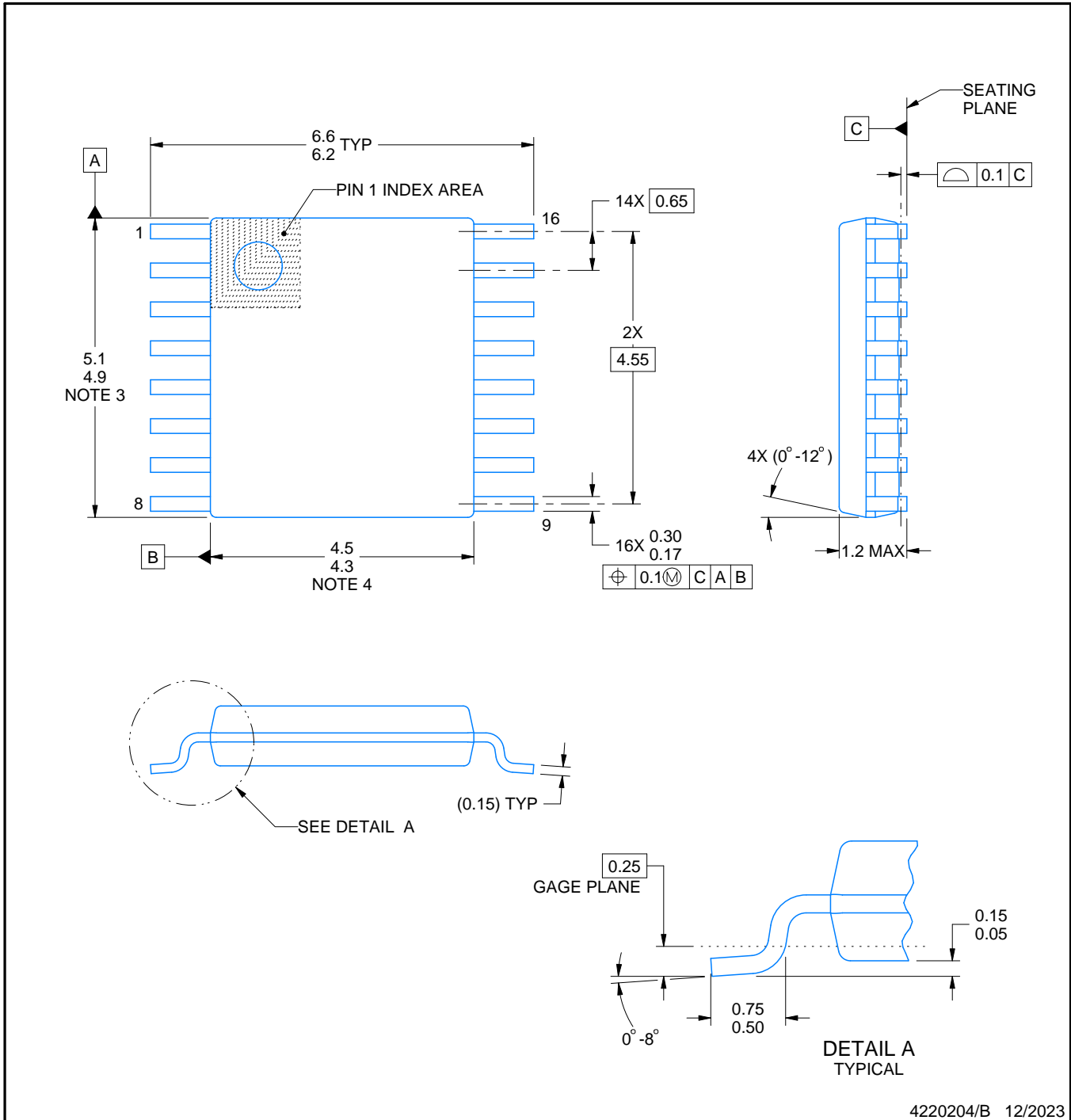
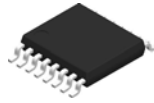
Device	Package Name	Package Type	Pins	SPQ	L (mm)	W (mm)	T (μm)	B (mm)
SN74CBT3257CD	D	SOIC	16	40	507	8	3940	4.32
SN74CBT3257CD.B	D	SOIC	16	40	507	8	3940	4.32
SN74CBT3257CPW	PW	TSSOP	16	90	530	10.2	3600	3.5
SN74CBT3257CPW.B	PW	TSSOP	16	90	530	10.2	3600	3.5



4220204/B 12/2023

NOTES:

1. All linear dimensions are in millimeters. Any dimensions in parenthesis are for reference only. Dimensioning and tolerancing per ASME Y14.5M.
2. This drawing is subject to change without notice.
3. This dimension does not include mold flash, protrusions, or gate burrs. Mold flash, protrusions, or gate burrs shall not exceed 0.15 mm per side.
4. This dimension does not include interlead flash. Interlead flash shall not exceed 0.25 mm per side.
5. Reference JEDEC registration MO-153.

# EXAMPLE BOARD LAYOUT

PW0016A

TSSOP - 1.2 mm max height

SMALL OUTLINE PACKAGE

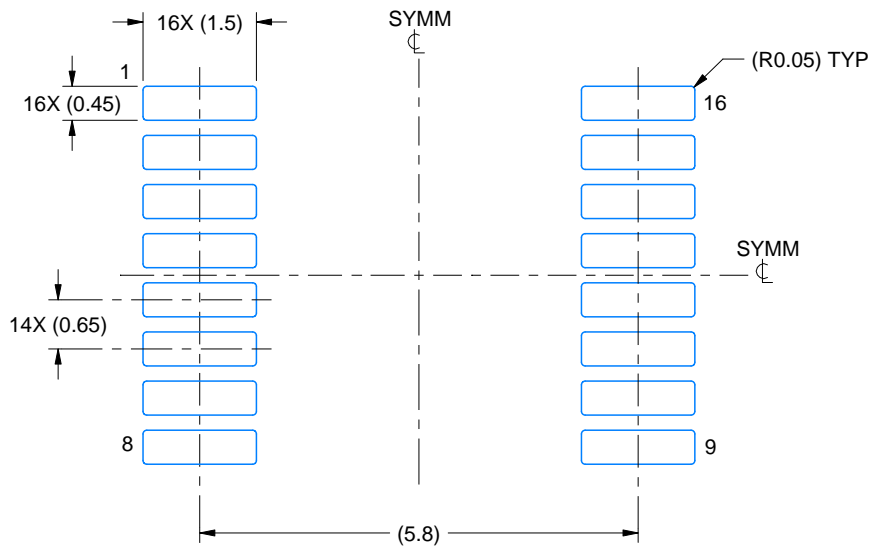

LAND PATTERN EXAMPLE  
EXPOSED METAL SHOWN  
SCALE: 10X

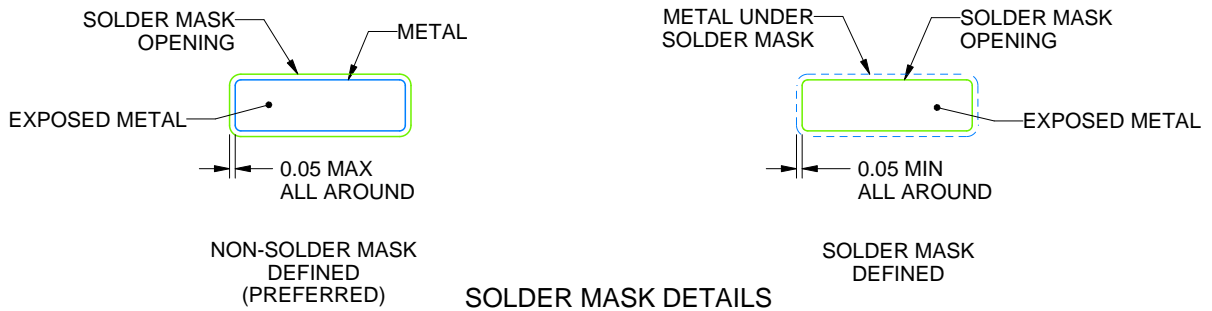

SOLDER MASK DETAILS

4220204/B 12/2023

NOTES: (continued)

- 6. Publication IPC-7351 may have alternate designs.
- 7. Solder mask tolerances between and around signal pads can vary based on board fabrication site.

# EXAMPLE STENCIL DESIGN

PW0016A

TSSOP - 1.2 mm max height

SMALL OUTLINE PACKAGE

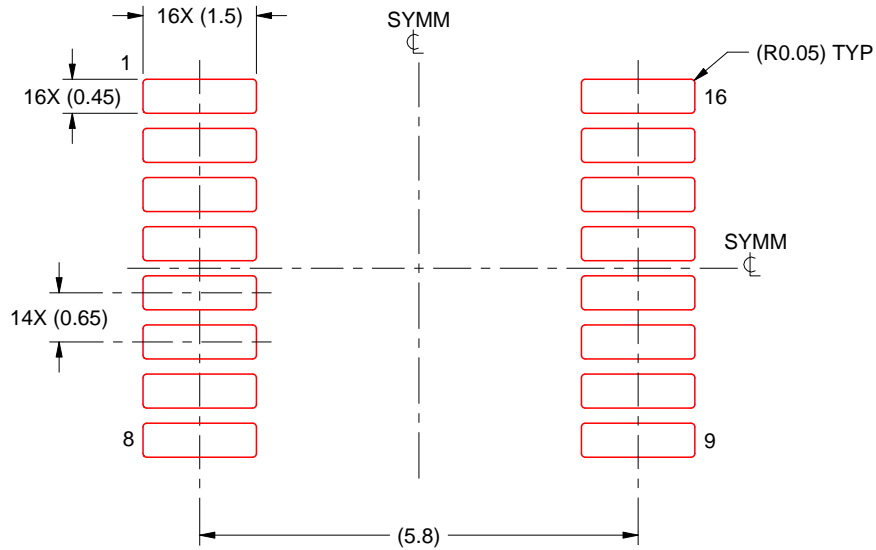

SOLDER PASTE EXAMPLE  
BASED ON 0.125 mm THICK STENCIL  
SCALE: 10X

4220204/B 12/2023

NOTES: (continued)

8. Laser cutting apertures with trapezoidal walls and rounded corners may offer better paste release. IPC-7525 may have alternate design recommendations.
9. Board assembly site may have different recommendations for stencil design.

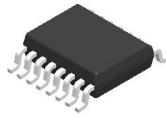

# DBQ0016A

# PACKAGE OUTLINE

## SSOP - 1.75 mm max height

SHRINK SMALL-OUTLINE PACKAGE

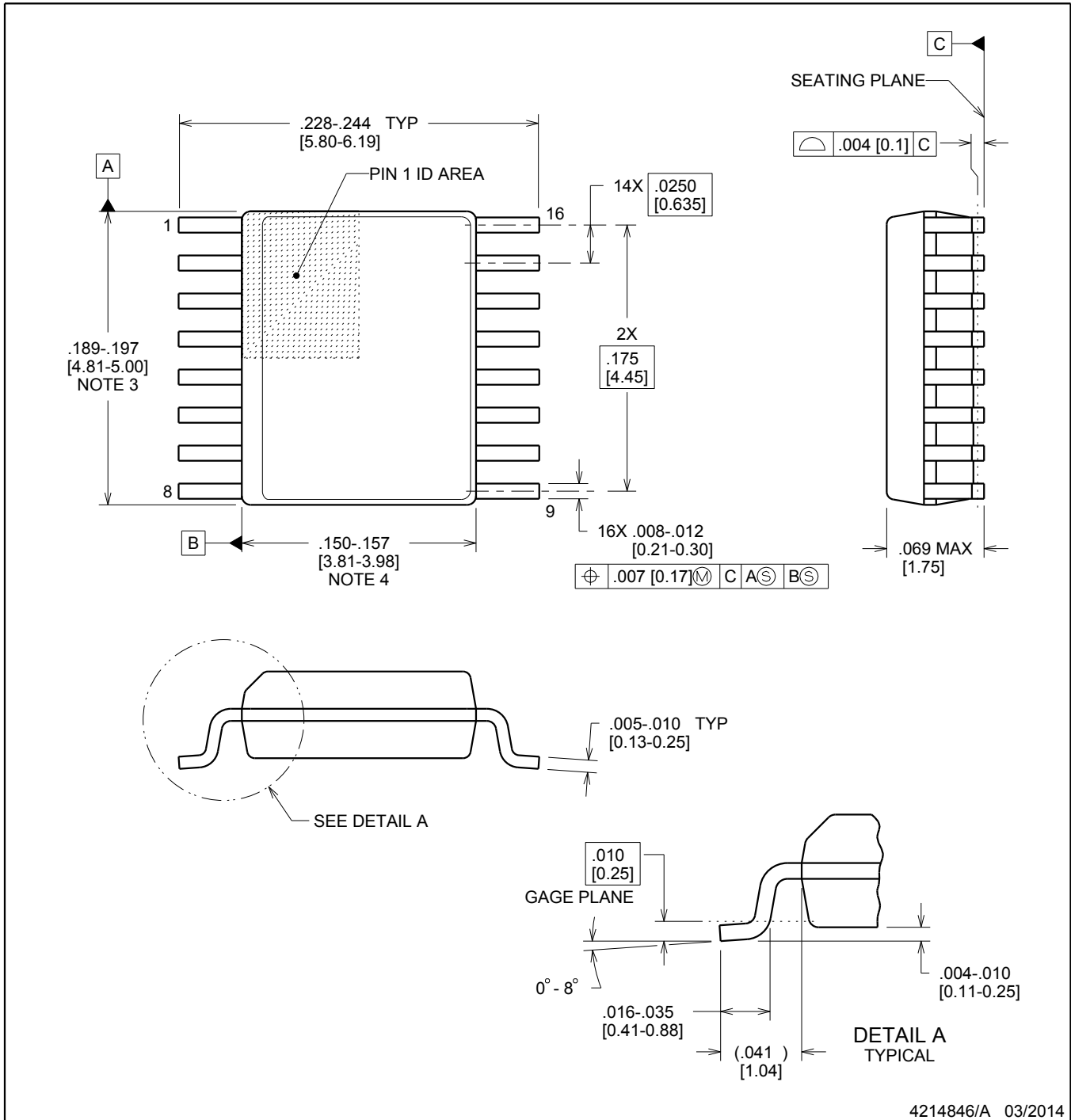

**NOTES:**

1. Linear dimensions are in inches [millimeters]. Dimensions in parenthesis are for reference only. Controlling dimensions are in inches. Dimensioning and tolerancing per ASME Y14.5M.
2. This drawing is subject to change without notice.
3. This dimension does not include mold flash, protrusions, or gate burrs. Mold flash, protrusions, or gate burrs shall not exceed .006 inch, per side.
4. This dimension does not include interlead flash.
5. Reference JEDEC registration MO-137, variation AB.

# EXAMPLE BOARD LAYOUT

DBQ0016A

SSOP - 1.75 mm max height

SHRINK SMALL-OUTLINE PACKAGE

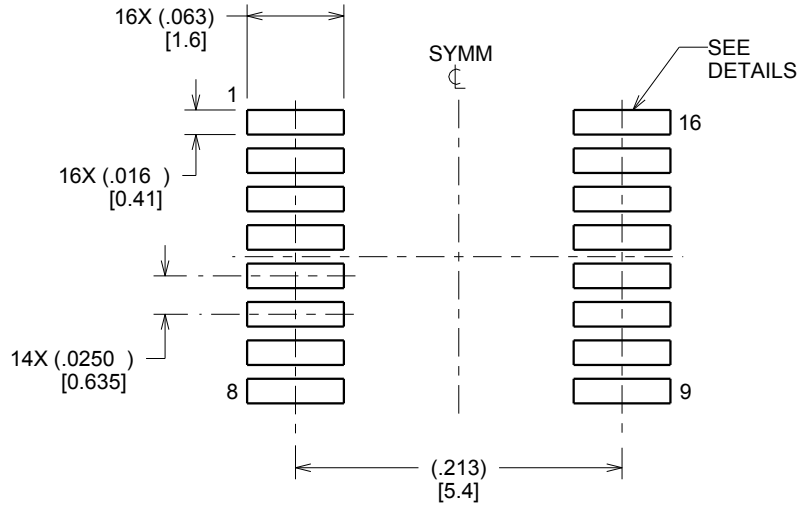

LAND PATTERN EXAMPLE  
SCALE:8X

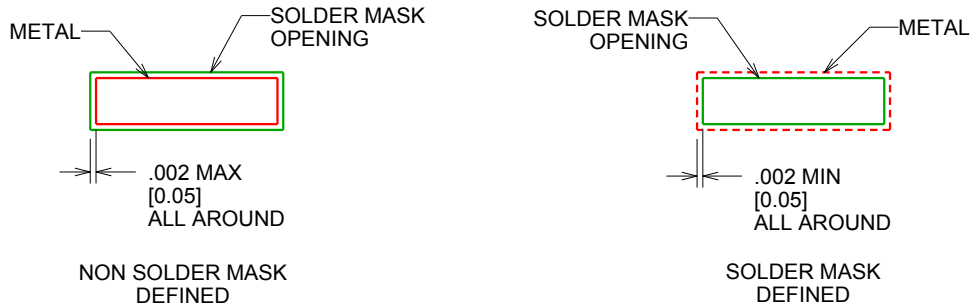

SOLDER MASK DETAILS

4214846/A 03/2014

NOTES: (continued)

6. Publication IPC-7351 may have alternate designs.

7. Solder mask tolerances between and around signal pads can vary based on board fabrication site.

# EXAMPLE STENCIL DESIGN

DBQ0016A

SSOP - 1.75 mm max height

SHRINK SMALL-OUTLINE PACKAGE

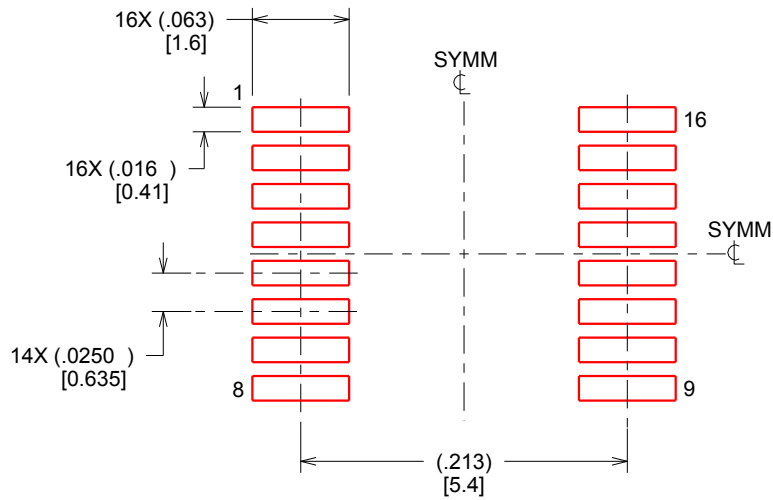

SOLDER PASTE EXAMPLE  
BASED ON .005 INCH [0.127 MM] THICK STENCIL  
SCALE:8X

4214846/A 03/2014

NOTES: (continued)

- 8. Laser cutting apertures with trapezoidal walls and rounded corners may offer better paste release. IPC-7525 may have alternate design recommendations.
- 9. Board assembly site may have different recommendations for stencil design.

RGY (R-PVQFN-N16)

PLASTIC QUAD FLATPACK NO-LEAD

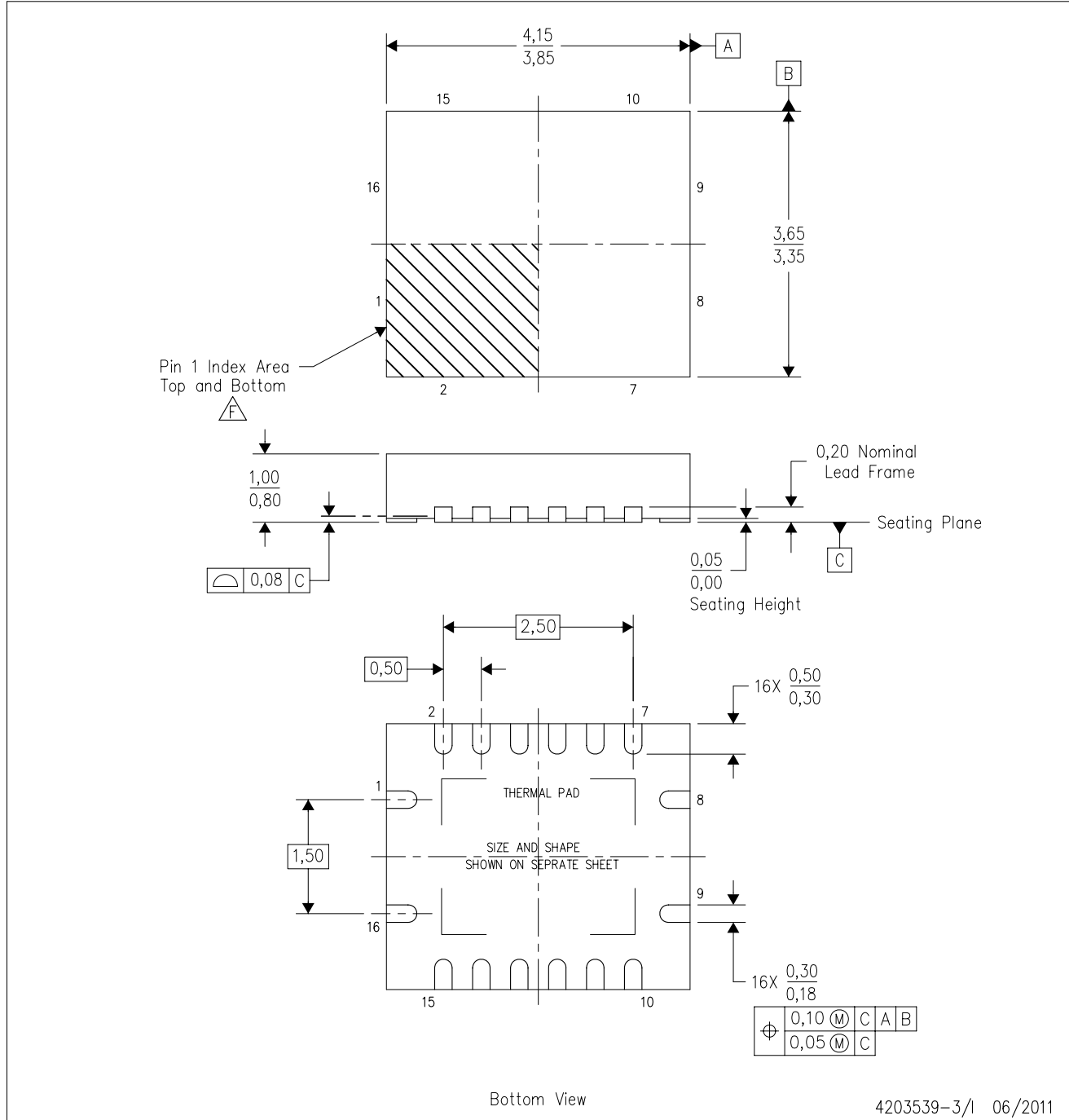

4203539-3/1 06/2011

- NOTES:
- All linear dimensions are in millimeters. Dimensioning and tolerancing per ASME Y14.5M-1994.
  - This drawing is subject to change without notice.
  - QFN (Quad Flatpack No-Lead) package configuration.
  - The package thermal pad must be soldered to the board for thermal and mechanical performance.
  - See the additional figure in the Product Data Sheet for details regarding the exposed thermal pad features and dimensions.
  - Pin 1 identifiers are located on both top and bottom of the package and within the zone indicated. The Pin 1 identifiers are either a molded, marked, or metal feature.
  - Package complies to JEDEC MO-241 variation BA.

RGY (R-PVQFN-N16)

PLASTIC QUAD FLATPACK NO-LEAD

**THERMAL INFORMATION**

This package incorporates an exposed thermal pad that is designed to be attached directly to an external heatsink. The thermal pad must be soldered directly to the printed circuit board (PCB). After soldering, the PCB can be used as a heatsink. In addition, through the use of thermal vias, the thermal pad can be attached directly to the appropriate copper plane shown in the electrical schematic for the device, or alternatively, can be attached to a special heatsink structure designed into the PCB. This design optimizes the heat transfer from the integrated circuit (IC).

For information on the Quad Flatpack No-Lead (QFN) package and its advantages, refer to Application Report, QFN/SON PCB Attachment, Texas Instruments Literature No. SLUA271. This document is available at [www.ti.com](http://www.ti.com).

The exposed thermal pad dimensions for this package are shown in the following illustration.

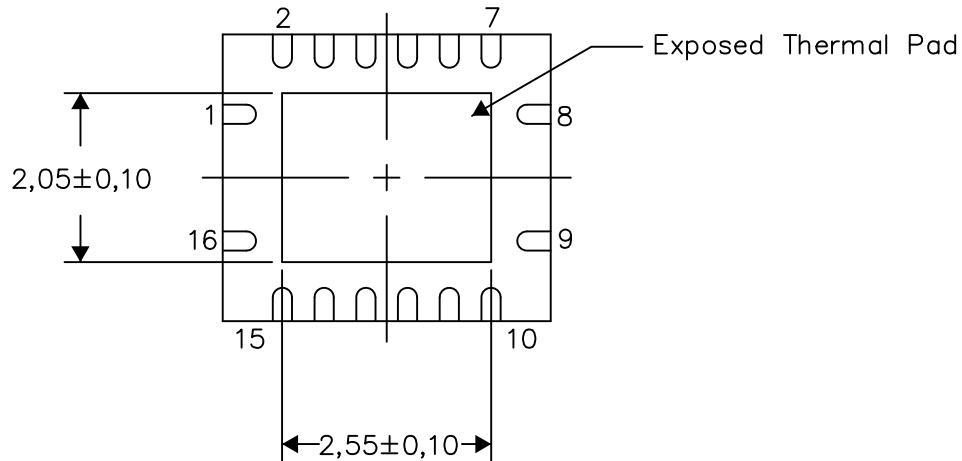

Bottom View

Exposed Thermal Pad Dimensions

4206353-3/P 03/14

NOTE: All linear dimensions are in millimeters

RGY (R-PVQFN-N16)

PLASTIC QUAD FLATPACK NO-LEAD

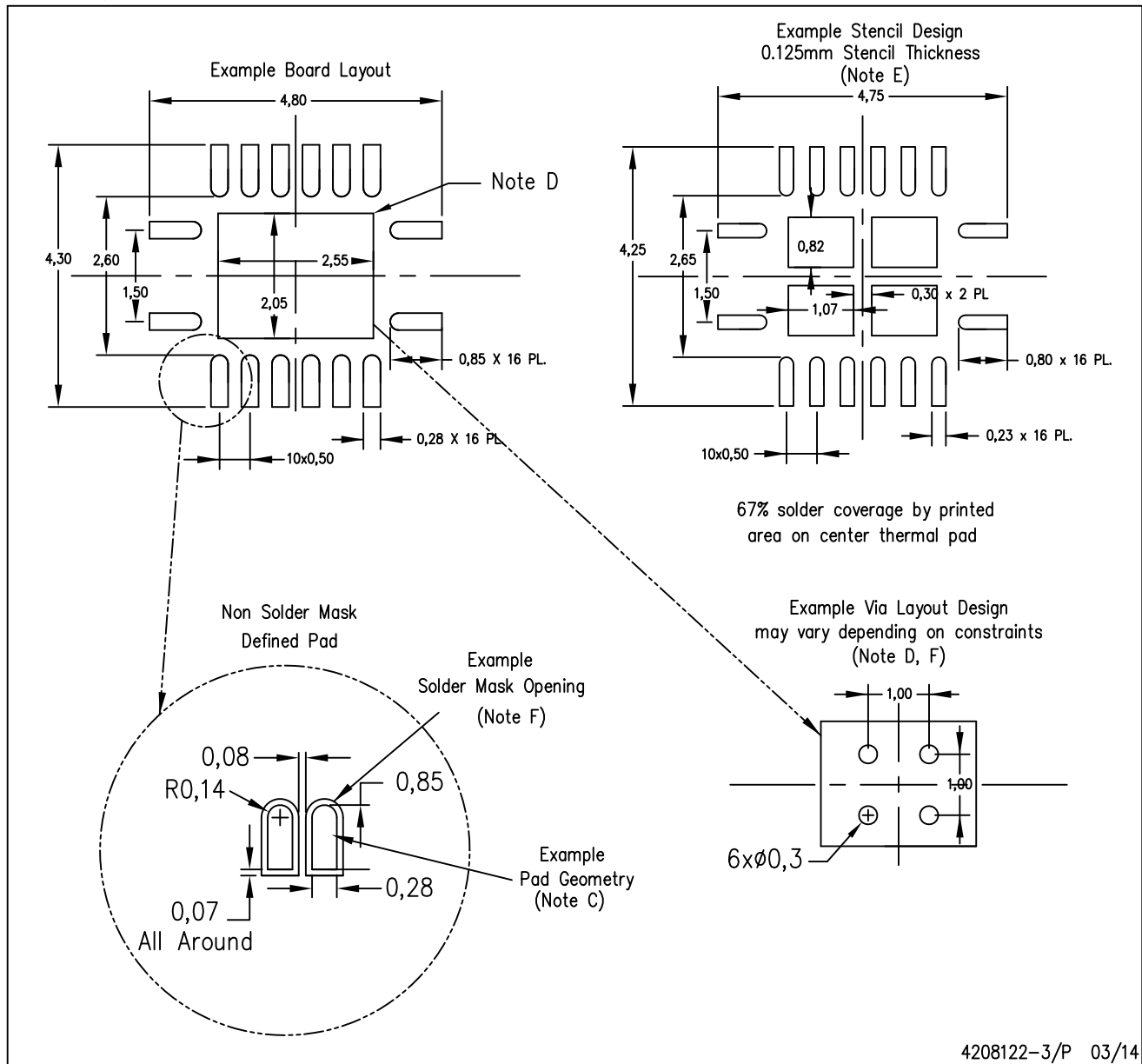

4208122-3/P 03/14

- NOTES:
- A. All linear dimensions are in millimeters.
  - B. This drawing is subject to change without notice.
  - C. Publication IPC-7351 is recommended for alternate designs.
  - D. This package is designed to be soldered to a thermal pad on the board. Refer to Application Note, Quad Flat-Pack QFN/SON PCB Attachment, Texas Instruments Literature No. SLUA271, and also the Product Data Sheets for specific thermal information, via requirements, and recommended board layout. These documents are available at [www.ti.com](http://www.ti.com) <<http://www.ti.com>>.
  - E. Laser cutting apertures with trapezoidal walls and also rounding corners will offer better paste release. Customers should contact their board assembly site for stencil design recommendations. Refer to IPC 7525 for stencil design considerations.
  - F. Customers should contact their board fabrication site for minimum solder mask web tolerances between signal pads.

D (R-PDSO-G16)

PLASTIC SMALL OUTLINE



- NOTES:
- A. All linear dimensions are in inches (millimeters).
  - B. This drawing is subject to change without notice.
  - C. Body length does not include mold flash, protrusions, or gate burrs. Mold flash, protrusions, or gate burrs shall not exceed 0.006 (0,15) each side.
  - D. Body width does not include interlead flash. Interlead flash shall not exceed 0.017 (0,43) each side.
  - E. Reference JEDEC MS-012 variation AC.

# DB0016A



# PACKAGE OUTLINE

## SSOP - 2 mm max height

SMALL OUTLINE PACKAGE



4220763/A 05/2022

### NOTES:

1. All linear dimensions are in millimeters. Any dimensions in parenthesis are for reference only. Dimensioning and tolerancing per ASME Y14.5M.
2. This drawing is subject to change without notice.
3. This dimension does not include mold flash, protrusions, or gate burrs. Mold flash, protrusions, or gate burrs shall not exceed 0.15 mm per side.
4. Reference JEDEC registration MO-150.

# EXAMPLE BOARD LAYOUT

DB0016A

SSOP - 2 mm max height

SMALL OUTLINE PACKAGE



LAND PATTERN EXAMPLE  
EXPOSED METAL SHOWN  
SCALE: 10X



4220763/A 05/2022

NOTES: (continued)

- 5. Publication IPC-7351 may have alternate designs.
- 6. Solder mask tolerances between and around signal pads can vary based on board fabrication site.

# EXAMPLE STENCIL DESIGN

DB0016A

SSOP - 2 mm max height

SMALL OUTLINE PACKAGE



SOLDER PASTE EXAMPLE  
BASED ON 0.125 mm THICK STENCIL  
SCALE: 10X

4220763/A 05/2022

NOTES: (continued)

7. Laser cutting apertures with trapezoidal walls and rounded corners may offer better paste release. IPC-7525 may have alternate design recommendations.
8. Board assembly site may have different recommendations for stencil design.

## IMPORTANT NOTICE AND DISCLAIMER

TI PROVIDES TECHNICAL AND RELIABILITY DATA (INCLUDING DATASHEETS), DESIGN RESOURCES (INCLUDING REFERENCE DESIGNS), APPLICATION OR OTHER DESIGN ADVICE, WEB TOOLS, SAFETY INFORMATION, AND OTHER RESOURCES "AS IS" AND WITH ALL FAULTS, AND DISCLAIMS ALL WARRANTIES, EXPRESS AND IMPLIED, INCLUDING WITHOUT LIMITATION ANY IMPLIED WARRANTIES OF MERCHANTABILITY, FITNESS FOR A PARTICULAR PURPOSE OR NON-INFRINGEMENT OF THIRD PARTY INTELLECTUAL PROPERTY RIGHTS.

These resources are intended for skilled developers designing with TI products. You are solely responsible for (1) selecting the appropriate TI products for your application, (2) designing, validating and testing your application, and (3) ensuring your application meets applicable standards, and any other safety, security, regulatory or other requirements.

These resources are subject to change without notice. TI grants you permission to use these resources only for development of an application that uses the TI products described in the resource. Other reproduction and display of these resources is prohibited. No license is granted to any other TI intellectual property right or to any third party intellectual property right. TI disclaims responsibility for, and you fully indemnify TI and its representatives against any claims, damages, costs, losses, and liabilities arising out of your use of these resources.

TI's products are provided subject to [TI's Terms of Sale](#), [TI's General Quality Guidelines](#), or other applicable terms available either on [ti.com](http://ti.com) or provided in conjunction with such TI products. TI's provision of these resources does not expand or otherwise alter TI's applicable warranties or warranty disclaimers for TI products. Unless TI explicitly designates a product as custom or customer-specified, TI products are standard, catalog, general purpose devices.

TI objects to and rejects any additional or different terms you may propose.

Copyright © 2026, Texas Instruments Incorporated

Last updated 10/2025