

# 具有清零和预设功能的 SNx4HC74 二路 D 类上升沿触发器

## 1 特性

- 缓冲输入
- 宽工作电压范围：2V 至 6V
- 宽工作温度范围：-40°C 至 +85°C
- 支持多达 10 个 LSTTL 负载的扇出
- 与 LSTTL 逻辑 IC 相比，可显著降低功耗

## 2 应用

- 将瞬时开关转换为拨动开关
- 二等分或四等分时钟信号

## 3 说明

SNx4HC74 器件包含两个具有异步预设和清零引脚的独立 D 类正边沿触发器。

器件信息<sup>(1)</sup>

器件型号	封装	封装尺寸 (标称值)
SN74HC74D	SOIC (14)	8.70mm × 3.90mm
SN74HC74DB	SSOP (14)	6.50mm × 5.30mm
SN74HC74N	PDIP (14)	19.30mm × 6.40mm
SN74HC74NS	SO (14)	10.20mm × 5.30mm
SN74HC74PW	TSSOP (14)	5.00mm × 4.40mm
SN54HC74J	CDIP (14)	21.30mm × 7.60mm
SN54HC74W	CFP (14)	9.20mm × 6.29mm
SN54HC74FK	LCCC (20)	8.90mm × 8.90mm

(1) 如需了解所有可用封装，请参阅数据表末尾的可订购产品附录。

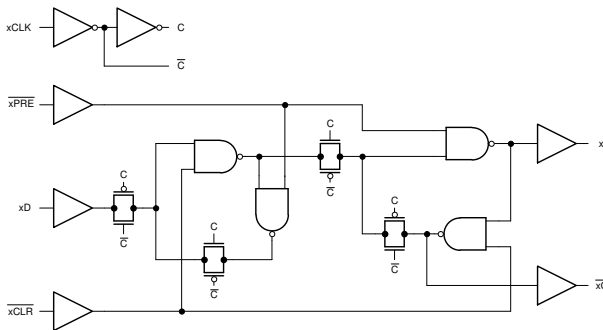

功能引脚分配



## Table of Contents

<b>1 特性</b> .....	1	<b>8 Detailed Description</b> .....	10
<b>2 应用</b> .....	1	8.1 Overview.....	10
<b>3 说明</b> .....	1	8.2 Functional Block Diagram.....	10
<b>4 Revision History</b> .....	2	8.3 Feature Description.....	10
<b>5 Pin Configuration and Functions</b> .....	3	8.4 Device Functional Modes.....	11
Pin Functions.....	3	<b>9 Application and Implementation</b> .....	12
<b>6 Specifications</b> .....	4	9.1 Application Information.....	12
6.1 Absolute Maximum Ratings.....	4	9.2 Typical Application.....	12
6.2 ESD Ratings.....	4	<b>10 Power Supply Recommendations</b> .....	15
6.3 Recommended Operating Conditions.....	4	<b>11 Layout</b> .....	16
6.4 Thermal Information.....	5	11.1 Layout Guidelines.....	16
6.5 Electrical Characteristics - 74.....	5	11.2 Layout Example.....	16
6.6 Electrical Characteristics - 54.....	6	<b>12 Device and Documentation Support</b> .....	17
6.7 Timing Requirements - 74.....	6	12.1 Documentation Support.....	17
6.8 Timing Requirements - 54.....	7	12.2 支持资源.....	17
6.9 Switching Characteristics - 74.....	7	12.3 Trademarks.....	17
6.10 Switching Characteristics - 54.....	8	12.4 静电放电警告.....	17
6.11 Operating Characteristics.....	8	12.5 术语表.....	17
6.12 Typical Characteristics.....	8	<b>13 Mechanical, Packaging, and Orderable Information</b> .....	17
<b>7 Parameter Measurement Information</b> .....	9		

## 4 Revision History

注：以前版本的页码可能与当前版本的页码不同

Changes from Revision E (December 2015) to Revision F (June 2021)	Page
• 更新至全新的数据表标准.....	1
• $R_{\theta JA}$ increased for the D (86 to 133.6 °C/W), DB (96 to 107.7 °C/W), NS (76 to 122.6 °C/W), and PW (113 to 151.7 °C/W) and decreased for the N package (80 to 61.9 °C/W) .....	5



## 6 Specifications

### 6.1 Absolute Maximum Ratings

over operating free-air temperature range (unless otherwise noted)<sup>(1)</sup>

		MIN	MAX	UNIT
V <sub>CC</sub>	Supply voltage	- 0.5	7	V
I <sub>IK</sub>	Input clamp current <sup>(2)</sup>	V <sub>I</sub> < - 0.5 V or V <sub>I</sub> > V <sub>CC</sub>		±20 mA
I <sub>OK</sub>	Output clamp current <sup>(2)</sup>	V <sub>I</sub> < - 0.5 V or V <sub>I</sub> > V <sub>CC</sub>		±20 mA
I <sub>O</sub>	Continuous output current	V <sub>O</sub> = 0 to V <sub>CC</sub>		±25 mA
	Continuous current through V <sub>CC</sub> or GND			±50 mA
T <sub>J</sub>	Junction temperature <sup>(3)</sup>			150 °C
T <sub>stg</sub>	Storage temperature	- 65	150	°C

- (1) Stresses beyond those listed under *Absolute Maximum Rating* may cause permanent damage to the device. These are stress ratings only, which do not imply functional operation of the device at these or any other conditions beyond those indicated under *Recommended Operating Condition*. Exposure to absolute-maximum-rated conditions for extended periods may affect device reliability.
- (2) The input and output voltage ratings may be exceeded if the input and output current ratings are observed.
- (3) Guaranteed by design.

### 6.2 ESD Ratings

		VALUE	UNIT
V <sub>(ESD)</sub>	Electrostatic discharge	Human-body model (HBM), per ANSI/ESDA/ JEDEC JS-001 <sup>(1)</sup>	±2000
		Charged-device model (CDM), per JEDEC specification JESD22-C101 <sup>(2)</sup>	±1500

- (1) JEDEC document JEP155 states that 500-V HBM allows safe manufacturing with a standard ESD control process.
- (2) JEDEC document JEP157 states that 250-V CDM allows safe manufacturing with a standard ESD control process.

### 6.3 Recommended Operating Conditions

over operating free-air temperature range (unless otherwise noted)

		MIN	NOM	MAX	UNIT
V <sub>CC</sub>	Supply voltage	2	5	6	V
V <sub>IH</sub>	High-level input voltage	V <sub>CC</sub> = 2 V	1.5		V
		V <sub>CC</sub> = 4.5 V	3.15		
		V <sub>CC</sub> = 6 V	4.2		
V <sub>IL</sub>	Low-level input voltage	V <sub>CC</sub> = 2 V		0.5	V
		V <sub>CC</sub> = 4.5 V		1.35	
		V <sub>CC</sub> = 6 V		1.8	
V <sub>I</sub>	Input voltage	0		V <sub>CC</sub>	V
V <sub>O</sub>	Output voltage	0		V <sub>CC</sub>	V
Δt/Δv	Input transition rise and fall rate	V <sub>CC</sub> = 2 V		1000	ns
		V <sub>CC</sub> = 4.5 V		500	
		V <sub>CC</sub> = 6 V		400	
T <sub>A</sub>	Operating free-air temperature	SN54HC00	- 55	125	°C
		SN74HC00	- 40	85	

## 6.4 Thermal Information

THERMAL METRIC <sup>(1)</sup>		SN74HC74					SN54HC74			UNIT
		D (SOIC)	DB (SSOP)	N (PDIP)	NS (SO)	PW (TSSOP)	J (CDIP)	W (CFP)	FK (LCCC)	
		14 PINS	14 PINS	14 PINS	14 PINS	14 PINS	14 PINS	14 PINS	20 PINS	
$R_{\theta JA}$	Junction-to-ambient thermal resistance	133.6	107.7	61.9	122.6	151.7	N/A	N/A	N/A	°C/W
$R_{\theta JC(top)}$	Junction-to-case (top) thermal resistance	89.0	57.4	49.7	81.8	79.4	15.05	14.65	5.61	°C/W
$R_{\theta JB}$	Junction-to-board thermal resistance	89.5	57.9	41.7	83.8	94.7	N/A	N/A	N/A	°C/W
$\Psi_{JT}$	Junction-to-top characterization parameter	45.5	17.6	29.3	45.4	25.2	N/A	N/A	N/A	°C/W
$\Psi_{JB}$	Junction-to-board characterization parameter	89.1	57.2	41.4	83.4	94.1	N/A	N/A	N/A	°C/W
$R_{\theta JC(bottom)}$	Junction-to-case (bottom) thermal resistance	N/A	N/A	N/A	N/A	N/A	N/A	N/A	N/A	°C/W

(1) For more information about traditional and new thermal metrics, see the [Semiconductor and IC Package Thermal Metrics](#) application report.

## 6.5 Electrical Characteristics - 74

over operating free-air temperature range; typical values measured at  $T_A = 25^\circ\text{C}$  (unless otherwise noted).

PARAMETER	TEST CONDITIONS	$V_{CC}$	Operating free-air temperature ( $T_A$ )						UNIT
			25°C			-40°C to 85°C			
			MIN	TYP	MAX	MIN	TYP	MAX	
$V_{OH}$	High-level output voltage	$V_I = V_{IH}$ or $V_{IL}$	$I_{OH} = -20 \mu\text{A}$	2 V	1.9	1.998		1.9	V
				4.5 V	4.4	4.499		4.4	
				6 V	5.9	5.999		5.9	
			$I_{OH} = -4 \text{ mA}$	4.5 V	3.98	4.3		3.84	
			$I_{OH} = -5.2 \text{ mA}$	6 V	5.48	5.8		5.34	
$V_{OL}$	Low-level output voltage	$V_I = V_{IH}$ or $V_{IL}$	$I_{OL} = 20 \mu\text{A}$	2 V		0.002	0.1		0.1
				4.5 V		0.001	0.1		0.1
				6 V		0.001	0.1		0.1
			$I_{OL} = 4 \text{ mA}$	4.5 V		0.17	0.26		0.33
			$I_{OL} = 5.2 \text{ mA}$	6 V		0.15	0.26		0.33
$I_I$	Input leakage current	$V_I = V_{CC}$ or 0	6 V				$\pm 0.1$	$\pm 1$	$\mu\text{A}$
$I_{CC}$	Supply current	$V_I = V_{CC}$ or 0	$I_O = 0$	6 V			4	40	$\mu\text{A}$
$C_i$	Input capacitance		2 V to 6 V		3	10		10	pF

### 6.6 Electrical Characteristics - 54

over operating free-air temperature range; typical values measured at TA = 25°C (unless otherwise noted).

PARAMETER	TEST CONDITIONS	V <sub>CC</sub>	Operating free-air temperature (T <sub>A</sub> )									UNIT
			25°C			- 40°C to 85°C			- 55°C to 125°C			
			MIN	TYP	MAX	MIN	TYP	MAX	MIN	TYP	MAX	
V <sub>OH</sub>	High-level output voltage	V <sub>I</sub> = V <sub>IH</sub> or V <sub>IL</sub>	I <sub>OH</sub> = -20 μA	2 V	1.9	1.998		1.9		1.9		V
				4.5 V	4.4	4.499		4.4		4.4		
			6 V	5.9	5.999		5.9		5.9			
			I <sub>OH</sub> = -6 mA	4.5 V	3.98	4.3		3.84		3.7		
6 V	5.48	5.8			5.34		5.2					
V <sub>OL</sub>	Low-level output voltage	V <sub>I</sub> = V <sub>IH</sub> or V <sub>IL</sub>	I <sub>OL</sub> = 20 μA	2 V		0.002	0.1			0.1		V
				4.5 V		0.001	0.1			0.1		
				6 V		0.001	0.1			0.1		
			I <sub>OL</sub> = 6 mA	4.5 V		0.17	0.26			0.33		
				6 V		0.15	0.26			0.33		
I <sub>I</sub>	Input leakage current	V <sub>I</sub> = V <sub>CC</sub> or 0	6 V			±0.1			±1		μA	
I <sub>CC</sub>	Supply current	V <sub>I</sub> = V <sub>CC</sub> or 0 I <sub>O</sub> = 0	6 V			2			20		40 μA	
C <sub>i</sub>	Input capacitance		2 V to 6 V		3	10			10		10 pF	

### 6.7 Timing Requirements - 74

over operating free-air temperature range (unless otherwise noted)

		V <sub>CC</sub>	Operating free-air temperature (T <sub>A</sub> )						UNIT	
			25°C			- 40°C to 85°C				
			MIN	TYP	MAX	MIN	TYP	MAX		
f <sub>clock</sub>	Clock frequency	2 V				6		5	MHz	
		4.5 V				31		25		
		6 V		0		36	0	29		
t <sub>w</sub>	Pulse duration	PRE or CLR low	2 V				100		125	ns
			4.5 V				20		25	
			6 V				14		21	
	CLK high or low	2 V				80		100		
		4.5 V				16		20		
		6 V				14		17		
t <sub>su</sub>	Setup time before CLK ↑	Data	2 V				100		125	ns
			4.5 V				20		25	
			6 V				17		21	
		PRE or CLR inactive	2 V				25		30	
			4.5 V				5		6	
			6 V				4		5	
t <sub>th</sub>	Hold time, data after CLK ↑	2 V		0			0		ns	
		4.5 V		0			0			
		6 V		0			0			

## 6.8 Timing Requirements - 54

over operating free-air temperature range; typical values measured at TA = 25°C (unless otherwise noted).

			V <sub>CC</sub>	Operating free-air temperature (T <sub>A</sub> )						UNIT			
				25°C			- 40°C to 85°C				- 55°C to 125°C		
				MIN	TYP	MAX	MIN	TYP	MAX		MIN	TYP	MAX
f <sub>clock</sub>	Clock frequency		2 V			6			5		4.2	ns	
			4.5 V			31			25		21		
			6 V	0		36	0		29	0	25		
t <sub>w</sub>	Pulse duration	PRE or CLR low	2 V			100			125		150	ns	
			4.5 V			20			25		30		
			6 V			14			21		25		
		CLK high or low	2 V			80			100		120		
			4.5 V			16			20		24		
			6 V			14			17		20		
t <sub>su</sub>	Setup time before CLK ↑	Data	2 V			100			125		150	ns	
			4.5 V			20			25		30		
			6 V			17			21		25		
		PRE or CLR inactive	2 V			25			30		40		
			4.5 V			5			6		8		
			6 V			4			5		7		
t <sub>h</sub>	Hold time, data after CLK ↑		2 V	0			0			0	MHz		
			4.5 V	0			0			0			
			6 V	0			0			0			

## 6.9 Switching Characteristics - 74

over operating free-air temperature range (unless otherwise noted)

PARAMETER	FROM	TO	V <sub>CC</sub>	Operating free-air temperature (T <sub>A</sub> )						UNIT
				25°C			- 40°C to 85°C			
				MIN	TYP	MAX	MIN	TYP	MAX	
f <sub>max</sub>			2 V	6	10		6			MHz
			4.5 V	31	50		25			
			6 V	36	60		29			
t <sub>pd</sub>	PRE or CLR	Q or $\bar{Q}$	2 V		70	230			290	ns
			4.5 V		20	46			58	
			6 V		15	39			49	
	CLK	Q or $\bar{Q}$	2 V		70	175			220	
			4.5 V		20	35			44	
			6 V		15	30			39	
t <sub>t</sub>		Q or $\bar{Q}$	2 V		28	75			95	ns
			4.5 V		8	15			19	
			6 V		6	13			16	

### 6.10 Switching Characteristics - 54

over operating free-air temperature range; typical values measured at  $T_A = 25^\circ\text{C}$  (unless otherwise noted).

PARAMETER	FROM	TO	$V_{CC}$	Operating free-air temperature ( $T_A$ )									UNIT
				25°C			- 40°C to 85°C			- 55°C to 125°C			
				MIN	TYP	MAX	MIN	TYP	MAX	MIN	TYP	MAX	
$f_{max}$			2 V	6	10		6			4.2	MHz		
			4.5 V	31	50		25			21			
			6 V	36	60		29			25			
$t_{pd}$	PRE or CLR	Q or $\bar{Q}$	2 V		70	230			290		345	ns	
			4.5 V		20	46			58		69		
			6 V		15	39			49		59		
	CLK	Q or $\bar{Q}$	2 V		70	175			220		250		
			4.5 V		20	35			44		50		
			6 V		15	30			39		42		
$t_t$		Q or $\bar{Q}$	2 V		28	75			95		110	ns	
			4.5 V		8	15			19		22		
			6 V		6	13			16		19		

### 6.11 Operating Characteristics

over operating free-air temperature range; typical values measured at  $T_A = 25^\circ\text{C}$  (unless otherwise noted).

PARAMETER	TEST CONDITIONS	$V_{CC}$	MIN	TYP	MAX	UNIT
$C_{pd}$	Power dissipation capacitance per gate No load	2 V to 6 V		35		pF

### 6.12 Typical Characteristics

$T_A = 25^\circ\text{C}$



图 6-1. Typical output voltage in the high state ( $V_{OH}$ )



图 6-2. Typical output voltage in the low state ( $V_{OL}$ )

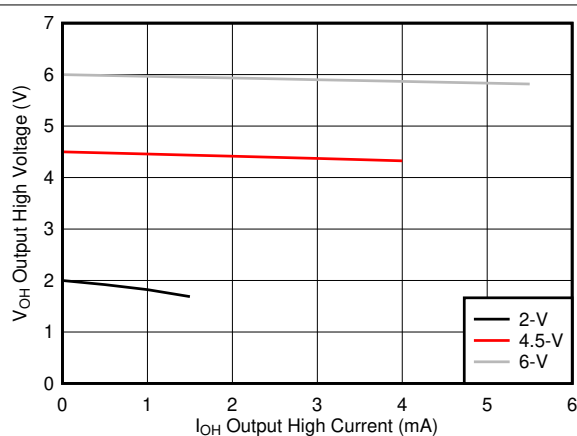

## 7 Parameter Measurement Information

- Phase relationships between waveforms were chosen arbitrarily. All input pulses are supplied by generators having the following characteristics:  $PRR \leq 1 \text{ MHz}$ ,  $Z_O = 50 \Omega$ ,  $t_t < 6 \text{ ns}$ .
- The outputs are measured one at a time, with one input transition  $t_t$  per measurement.

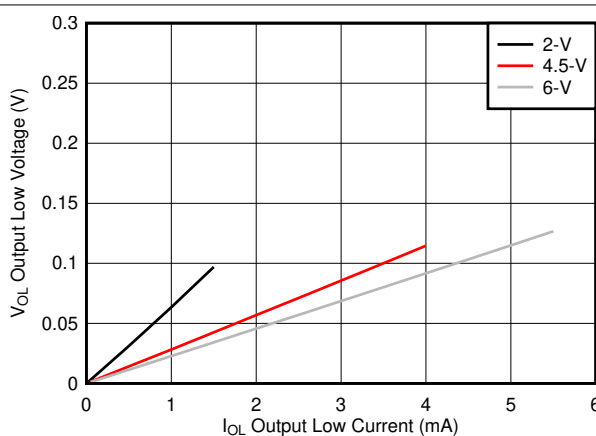
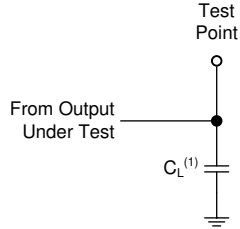

A.  $C_L = 50 \text{ pF}$  and includes probe and jig capacitance.

图 7-1. Load Circuit



图 7-3. Voltage Waveforms Setup and Hold Times



A.  $t_t$  is the greater of  $t_r$  and  $t_f$ .

图 7-2. Voltage Waveforms Transition Times

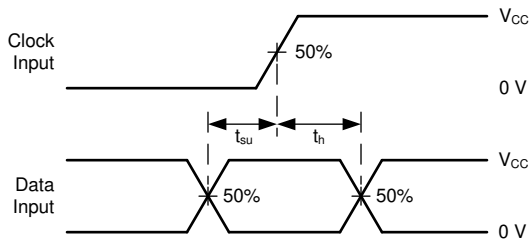
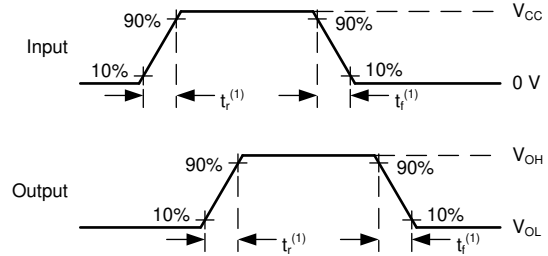

图 7-4. Voltage Waveforms Pulse Width



A. The maximum between  $t_{PLH}$  and  $t_{PHL}$  is used for  $t_{pd}$ .

图 7-5. Voltage Waveforms Propagation Delays

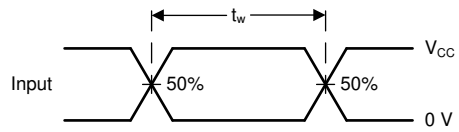
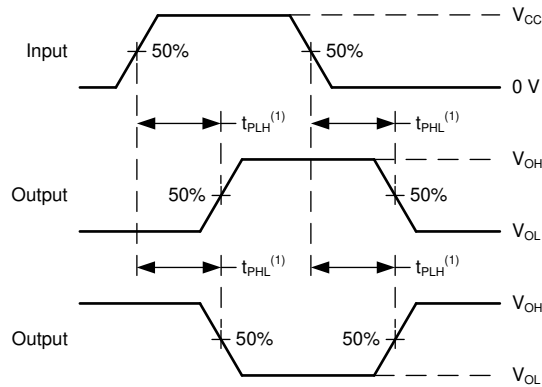
## 8 Detailed Description

### 8.1 Overview

The SNx4HC74 devices contain two independent D-type positive-edge-triggered flip-flops with asynchronous preset and clear pins for each.

### 8.2 Functional Block Diagram

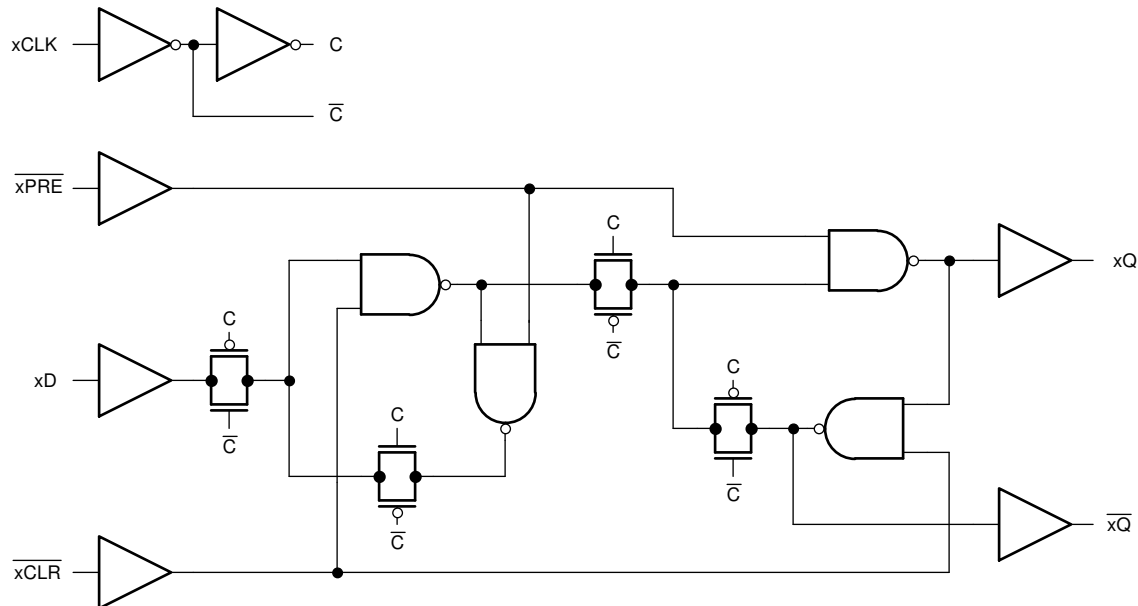

### 8.3 Feature Description

#### 8.3.1 Balanced CMOS Push-Pull Outputs

A balanced output allows the device to sink and source similar currents. The drive capability of this device may create fast edges into light loads so routing and load conditions should be considered to prevent ringing. Additionally, the outputs of this device are capable of driving larger currents than the device can sustain without being damaged. It is important for the output power of the device to be limited to avoid damage due to over-current. The electrical and thermal limits defined in the [§ 6.1](#) must be followed at all times.

The SN74HC74 can drive a load with a total capacitance less than or equal to the maximum load listed in the [§ 6.9](#) connected to a high-impedance CMOS input while still meeting all of the datasheet specifications. Larger capacitive loads can be applied, however it is not recommended to exceed the provided load value. If larger capacitive loads are required, it is recommended to add a series resistor between the output and the capacitor to limit output current to the values given in the [§ 6.1](#).

#### 8.3.2 Standard CMOS Inputs

Standard CMOS inputs are high impedance and are typically modeled as a resistor from the input to ground in parallel with the input capacitance given in the [§ 6.5](#). The worst case resistance is calculated with the maximum input voltage, given in the [§ 6.1](#), and the maximum input leakage current, given in the [§ 6.5](#), using ohm's law ( $R = V \div I$ ).

Signals applied to the inputs need to have fast edge rates, as defined by the input transition time in the [§ 6.3](#) to avoid excessive current consumption and oscillations. If a slow or noisy input signal is required, a device with a Schmitt-trigger input should be used to condition the input signal prior to the standard CMOS input.

### 8.3.3 Clamp Diode Structure

The inputs and outputs to this device have both positive and negative clamping diodes as depicted in 图 8-1.

**CAUTION**

Voltages beyond the values specified in the 节 6.1 table can cause damage to the device. The recommended input and output voltage ratings may be exceeded if the input and output clamp-current ratings are observed.



图 8-1. Electrical Placement of Clamping Diodes for Each Input and Output

### 8.4 Device Functional Modes

表 8-1. Function Table

INPUTS				OUTPUTS	
PRE	CLR	CLK	D	Q	$\bar{Q}$
L	H	X	X	H	L
H	L	X	X	L	H
L	L	X	X	H <sup>(1)</sup>	H <sup>(1)</sup>
H	H	↑	H	H	L
H	H	↑	L	L	H
H	H	L	X	Q <sub>0</sub>	$\bar{Q}$ <sub>0</sub>

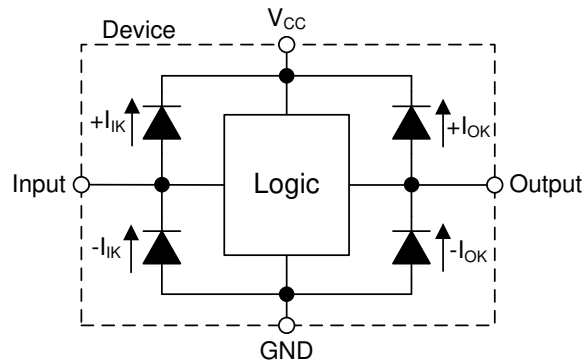
- (1) This configuration is nonstable; that is, it does not persist when  $\overline{\text{PRE}}$  or  $\overline{\text{CLR}}$  returns to its inactive (high) level.

## 9 Application and Implementation

### 备注

以下应用部分中的信息不属于 TI 器件规格的范围，TI 不担保其准确性和完整性。TI 的客户应负责确定器件是否适用于其应用。客户应验证并测试其设计，以确保系统功能。

### 9.1 Application Information

Toggle switches are typically large, mechanically complex and relatively expensive. It is desirable to use a momentary switch instead because they are small, mechanically simple and low cost. Some systems require a toggle switch's functionality but are space or cost constrained and must use a momentary switch instead.

If the data input (D) of the D-type flip-flop is tied to the inverted output ( $\bar{Q}$ ), then each clock pulse will cause the value at the output (Q) to toggle. The momentary switch can be debounced and connected through a Schmitt-trigger buffer to the clock input (CLK) to toggle the output.

This application also utilizes a power-on reset circuit to ensure that the output always starts in the LOW state when power is applied.

### 9.2 Typical Application



图 9-1. Typical application schematic

#### 9.2.1 Design Requirements

##### 9.2.1.1 Power Considerations

Ensure the desired supply voltage is within the range specified in the [§ 6.3](#). The supply voltage sets the device's electrical characteristics as described in the [§ 6.5](#).

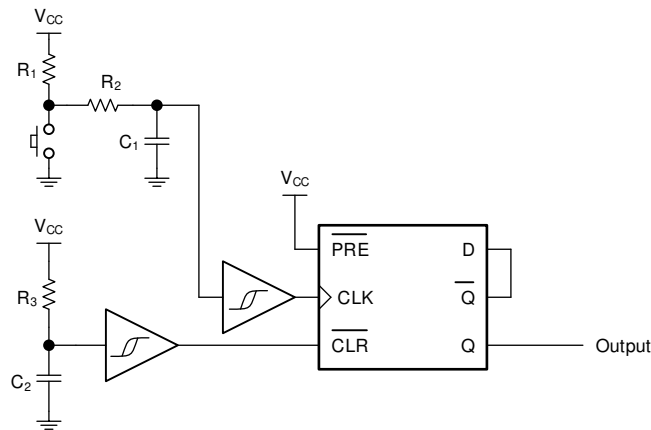
The supply must be capable of sourcing current equal to the total current to be sourced by all outputs of the SN74HC74 plus the maximum supply current,  $I_{CC}$ , listed in the [§ 6.5](#). The logic device can only source or sink as much current as it is provided at the supply and ground pins, respectively. Be sure not to exceed the maximum total current through GND or  $V_{CC}$  listed in the [§ 6.1](#).

Total power consumption can be calculated using the information provided in [CMOS Power Consumption and  \$C\_{pd}\$  Calculation](#).

Thermal increase can be calculated using the information provided in [Thermal Characteristics of Standard Linear and Logic \(SLL\) Packages and Devices](#).

### CAUTION

The maximum junction temperature,  $T_J(\text{max})$  listed in the § 6.1, is an *additional limitation* to prevent damage to the device. Do not violate any values listed in the § 6.1. These limits are provided to prevent damage to the device.

#### 9.2.1.2 Input Considerations

Unused inputs must be terminated to either  $V_{CC}$  or ground. These can be directly terminated if the input is completely unused, or they can be connected with a pull-up or pull-down resistor if the input is to be used sometimes, but not always. A pull-up resistor is used for a default state of HIGH, and a pull-down resistor is used for a default state of LOW. The resistor size is limited by drive current of the controller, leakage current into the SN74HC74, as specified in the § 6.5, and the desired input transition rate. A 10-k $\Omega$  resistor value is often used due to these factors.

The SN74HC74 has standard CMOS inputs, so input signal edge rates cannot be slow. Slow input edge rates can cause oscillations and damaging shoot-through current. The recommended rates are defined in the § 6.3.

Refer to the § 8.3 for additional information regarding the inputs for this device.

#### 9.2.1.3 Output Considerations

The positive supply voltage is used to produce the output HIGH voltage. Drawing current from the output will decrease the output voltage as specified by the  $V_{OH}$  specification in the § 6.5. Similarly, the ground voltage is used to produce the output LOW voltage. Sinking current into the output will increase the output voltage as specified by the  $V_{OL}$  specification in the § 6.5.

Unused outputs can be left floating. Do not connect outputs directly to  $V_{CC}$  or ground.

Refer to § 8.3 for additional information regarding the outputs for this device.

#### 9.2.1.4 Timing Considerations

The SN74HC74 is a clocked device. As such, it requires special timing considerations to ensure normal operation.

Primary timing factors to consider:

- Maximum clock frequency: the maximum operating clock frequency defined in § 6.7 is the maximum frequency at which the device is guaranteed to function. This value refers specifically to the triggering waveform, measuring from one trigger level to the next.
- Pulse duration: ensure that the triggering event duration is larger than the minimum pulse duration, as defined in the § 6.7.
- Setup time: ensure that the data has changed at least one setup time prior to the triggering event, as defined in the § 6.7.
- Hold time: ensure that the data remains in the desired state at least one hold time after the triggering event, as defined in the § 6.7.

#### 9.2.2 Detailed Design Procedure

1. Add a decoupling capacitor from  $V_{CC}$  to GND. The capacitor needs to be placed physically close to the device and electrically close to both the  $V_{CC}$  and GND pins. An example layout is shown in the § 11.
2. Ensure the capacitive load at the output is  $\leq 70$  pF. This is not a hard limit, however it will ensure optimal performance. This can be accomplished by providing short, appropriately sized traces from the SN74HC74 to the receiving device.
3. Ensure the resistive load at the output is larger than  $(V_{CC} / I_O(\text{max})) \Omega$ . This will ensure that the maximum output current from the § 6.1 is not violated. Most CMOS inputs have a resistive load measured in megaohms; much larger than the minimum calculated above.

- Thermal issues are rarely a concern for logic gates, however the power consumption and thermal increase can be calculated using the steps provided in the application report, [CMOS Power Consumption and Cpd Calculation](#)

### 9.2.3 Application Curves

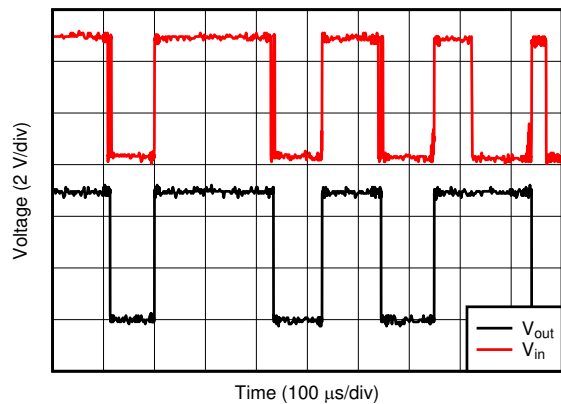

D001

**图 9-2. Waveform for non-debounced switch.**

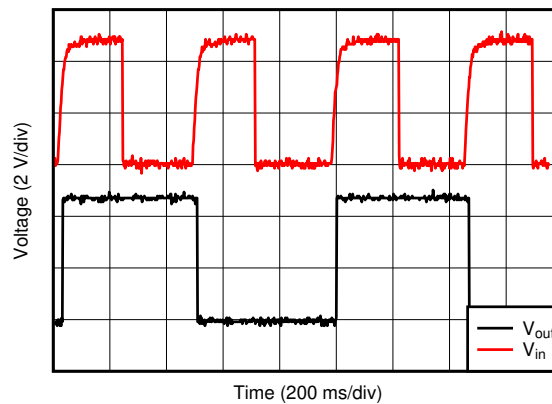

D002

**图 9-3. Waveform for debounced switch.**

## 10 Power Supply Recommendations

The power supply can be any voltage between the minimum and maximum supply voltage rating located in the [# 6.3](#). Each  $V_{CC}$  terminal should have a bypass capacitor to prevent power disturbance. A 0.1- $\mu$ F capacitor is recommended for this device. It is acceptable to parallel multiple bypass caps to reject different frequencies of noise. The 0.1- $\mu$ F and 1- $\mu$ F capacitors are commonly used in parallel. The bypass capacitor should be installed as close to the power terminal as possible for best results, as shown in [图 11-1](#).

## 11 Layout

### 11.1 Layout Guidelines

When using multiple-input and multiple-channel logic devices inputs must not ever be left floating. In many cases, functions or parts of functions of digital logic devices are unused; for example, when only two inputs of a triple-input AND gate are used. Such unused input pins must not be left unconnected because the undefined voltages at the outside connections result in undefined operational states. All unused inputs of digital logic devices must be connected to a logic high or logic low voltage, as defined by the input voltage specifications, to prevent them from floating. The logic level that must be applied to any particular unused input depends on the function of the device. Generally, the inputs are tied to GND or  $V_{CC}$ , whichever makes more sense for the logic function or is more convenient.

### 11.2 Layout Example



图 11-1. Example layout for the SN74HC74



## 12 Device and Documentation Support

### 12.1 Documentation Support

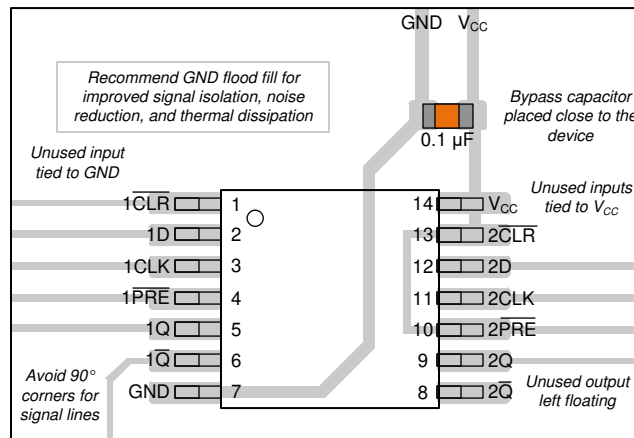
#### 12.1.1 Related Documentation

For related documentation see the following:

- [HCMOS Design Considerations](#)
- [CMOS Power Consumption and CPD Calculation](#)
- [Designing with Logic](#)

### 12.2 支持资源

[TI E2E™ 支持论坛](#)是工程师的重要参考资料，可直接从专家获得快速、经过验证的解答和设计帮助。搜索现有解答或提出自己的问题可获得所需的快速设计帮助。

链接的内容由各个贡献者“按原样”提供。这些内容并不构成 TI 技术规范，并且不一定反映 TI 的观点；请参阅 TI 的《使用条款》。

### 12.3 Trademarks

TI E2E™ is a trademark of Texas Instruments.  
所有商标均为其各自所有者的财产。

### 12.4 静电放电警告



静电放电 (ESD) 会损坏这个集成电路。德州仪器 (TI) 建议通过适当的预防措施处理所有集成电路。如果不遵守正确的处理和安装程序，可能会损坏集成电路。

ESD 的损坏小至导致微小的性能降级，大至整个器件故障。精密的集成电路可能更容易受到损坏，这是因为非常细微的参数更改都可能会导致器件与其发布的规格不相符。

### 12.5 术语表

[TI 术语表](#) 本术语表列出并解释了术语、首字母缩略词和定义。

## 13 Mechanical, Packaging, and Orderable Information

The following pages include mechanical, packaging, and orderable information. This information is the most current data available for the designated devices. This data is subject to change without notice and revision of this document. For browser-based versions of this data sheet, refer to the left-hand navigation.

**PACKAGING INFORMATION**

Orderable part number	Status (1)	Material type (2)	Package   Pins	Package qty   Carrier	RoHS (3)	Lead finish/ Ball material (4)	MSL rating/ Peak reflow (5)	Op temp (°C)	Part marking (6)
<a href="#">5962-8405601VCA</a>	Active	Production	CDIP (J)   14	25   TUBE	No	SNPB	N/A for Pkg Type	-55 to 125	5962-8405601VCA A SNV54HC74J
5962-8405601VCA.A	Active	Production	CDIP (J)   14	25   TUBE	No	SNPB	N/A for Pkg Type	-55 to 125	5962-8405601VCA A SNV54HC74J
<a href="#">5962-8405601VDA</a>	Active	Production	CFP (W)   14	25   TUBE	No	SNPB	N/A for Pkg Type	-55 to 125	5962-8405601VDA A SNV54HC74W
5962-8405601VDA.A	Active	Production	CFP (W)   14	25   TUBE	No	SNPB	N/A for Pkg Type	-55 to 125	5962-8405601VDA A SNV54HC74W
<a href="#">84056012A</a>	Active	Production	LCCC (FK)   20	55   TUBE	No	SNPB	N/A for Pkg Type	-55 to 125	84056012A SNJ54HC 74FK
<a href="#">8405601CA</a>	Active	Production	CDIP (J)   14	25   TUBE	No	SNPB	N/A for Pkg Type	-55 to 125	8405601CA SNJ54HC74J
<a href="#">8405601DA</a>	Active	Production	CFP (W)   14	25   TUBE	No	SNPB	N/A for Pkg Type	-55 to 125	8405601DA SNJ54HC74W
<a href="#">JM38510/65302B2A</a>	Active	Production	LCCC (FK)   20	55   TUBE	No	SNPB	N/A for Pkg Type	-55 to 125	JM38510/ 65302B2A
JM38510/65302B2A.A	Active	Production	LCCC (FK)   20	55   TUBE	No	SNPB	N/A for Pkg Type	-55 to 125	JM38510/ 65302B2A
<a href="#">JM38510/65302BCA</a>	Active	Production	CDIP (J)   14	25   TUBE	No	SNPB	N/A for Pkg Type	-55 to 125	JM38510/ 65302BCA
JM38510/65302BCA.A	Active	Production	CDIP (J)   14	25   TUBE	No	SNPB	N/A for Pkg Type	-55 to 125	JM38510/ 65302BCA
<a href="#">JM38510/65302BDA</a>	Active	Production	CFP (W)   14	25   TUBE	No	SNPB	N/A for Pkg Type	-55 to 125	JM38510/ 65302BDA
JM38510/65302BDA.A	Active	Production	CFP (W)   14	25   TUBE	No	SNPB	N/A for Pkg Type	-55 to 125	JM38510/ 65302BDA
<a href="#">M38510/65302B2A</a>	Active	Production	LCCC (FK)   20	55   TUBE	No	SNPB	N/A for Pkg Type	-55 to 125	JM38510/ 65302B2A

Orderable part number	Status (1)	Material type (2)	Package   Pins	Package qty   Carrier	RoHS (3)	Lead finish/ Ball material (4)	MSL rating/ Peak reflow (5)	Op temp (°C)	Part marking (6)
<a href="#">M38510/65302BCA</a>	Active	Production	CDIP (J)   14	25   TUBE	No	SNPB	N/A for Pkg Type	-55 to 125	JM38510/ 65302BCA
<a href="#">M38510/65302BDA</a>	Active	Production	CFP (W)   14	25   TUBE	No	SNPB	N/A for Pkg Type	-55 to 125	JM38510/ 65302BDA
<a href="#">SN54HC74J</a>	Active	Production	CDIP (J)   14	25   TUBE	No	SNPB	N/A for Pkg Type	-55 to 125	SN54HC74J
SN54HC74J.A	Active	Production	CDIP (J)   14	25   TUBE	No	SNPB	N/A for Pkg Type	-55 to 125	SN54HC74J
<a href="#">SN74HC74D</a>	Obsolete	Production	SOIC (D)   14	-	-	Call TI	Call TI	-40 to 85	HC74
<a href="#">SN74HC74DBR</a>	Active	Production	SSOP (DB)   14	2000   LARGE T&R	Yes	NIPDAU	Level-1-260C-UNLIM	-40 to 85	HC74
SN74HC74DBR.A	Active	Production	SSOP (DB)   14	2000   LARGE T&R	Yes	NIPDAU	Level-1-260C-UNLIM	-40 to 85	HC74
SN74HC74DBRG4	Active	Production	SSOP (DB)   14	2000   LARGE T&R	Yes	NIPDAU	Level-1-260C-UNLIM	-40 to 85	HC74
<a href="#">SN74HC74DR</a>	Active	Production	SOIC (D)   14	2500   LARGE T&R	Yes	NIPDAU   SN	Level-1-260C-UNLIM	-40 to 85	HC74
SN74HC74DR.A	Active	Production	SOIC (D)   14	2500   LARGE T&R	Yes	NIPDAU	Level-1-260C-UNLIM	-40 to 85	HC74
<a href="#">SN74HC74DRG4</a>	Active	Production	SOIC (D)   14	2500   LARGE T&R	Yes	NIPDAU	Level-1-260C-UNLIM	-40 to 85	HC74
SN74HC74DRG4.A	Active	Production	SOIC (D)   14	2500   LARGE T&R	Yes	NIPDAU	Level-1-260C-UNLIM	-40 to 85	HC74
<a href="#">SN74HC74DT</a>	Obsolete	Production	SOIC (D)   14	-	-	Call TI	Call TI	-40 to 85	HC74
<a href="#">SN74HC74N</a>	Active	Production	PDIP (N)   14	25   TUBE	Yes	NIPDAU	N/A for Pkg Type	-40 to 85	SN74HC74N
SN74HC74N.A	Active	Production	PDIP (N)   14	25   TUBE	Yes	NIPDAU	N/A for Pkg Type	-40 to 85	SN74HC74N
SN74HC74NE4	Active	Production	PDIP (N)   14	25   TUBE	Yes	NIPDAU	N/A for Pkg Type	-40 to 85	SN74HC74N
<a href="#">SN74HC74NSR</a>	Active	Production	SOP (NS)   14	2000   LARGE T&R	Yes	NIPDAU	Level-1-260C-UNLIM	-40 to 85	HC74
SN74HC74NSR.A	Active	Production	SOP (NS)   14	2000   LARGE T&R	Yes	NIPDAU	Level-1-260C-UNLIM	-40 to 85	HC74
SN74HC74NSRG4	Active	Production	SOP (NS)   14	2000   LARGE T&R	Yes	NIPDAU	Level-1-260C-UNLIM	-40 to 85	HC74
SN74HC74NSRG4.A	Active	Production	SOP (NS)   14	2000   LARGE T&R	Yes	NIPDAU	Level-1-260C-UNLIM	-40 to 85	HC74
<a href="#">SN74HC74PW</a>	Obsolete	Production	TSSOP (PW)   14	-	-	Call TI	Call TI	-40 to 85	HC74
<a href="#">SN74HC74PWR</a>	Active	Production	TSSOP (PW)   14	2000   LARGE T&R	Yes	NIPDAU   SN	Level-1-260C-UNLIM	-40 to 85	HC74
SN74HC74PWR.A	Active	Production	TSSOP (PW)   14	2000   LARGE T&R	Yes	NIPDAU	Level-1-260C-UNLIM	-40 to 85	HC74
SN74HC74PWR1G4	Active	Production	TSSOP (PW)   14	2000   LARGE T&R	Yes	NIPDAU	Level-1-260C-UNLIM	-40 to 85	HC74
SN74HC74PWR1G4.A	Active	Production	TSSOP (PW)   14	2000   LARGE T&R	Yes	NIPDAU	Level-1-260C-UNLIM	-40 to 85	HC74
<a href="#">SN74HC74PWT</a>	Obsolete	Production	TSSOP (PW)   14	-	-	Call TI	Call TI	-40 to 85	HC74
<a href="#">SNJ54HC74FK</a>	Active	Production	LCCC (FK)   20	55   TUBE	No	SNPB	N/A for Pkg Type	-55 to 125	84056012A SNJ54HC 74FK

Orderable part number	Status (1)	Material type (2)	Package   Pins	Package qty   Carrier	RoHS (3)	Lead finish/ Ball material (4)	MSL rating/ Peak reflow (5)	Op temp (°C)	Part marking (6)
SNJ54HC74FK.A	Active	Production	LCCC (FK)   20	55   TUBE	No	SNPB	N/A for Pkg Type	-55 to 125	84056012A SNJ54HC 74FK
<a href="#">SNJ54HC74J</a>	Active	Production	CDIP (J)   14	25   TUBE	No	SNPB	N/A for Pkg Type	-55 to 125	8405601CA SNJ54HC74J
SNJ54HC74J.A	Active	Production	CDIP (J)   14	25   TUBE	No	SNPB	N/A for Pkg Type	-55 to 125	8405601CA SNJ54HC74J
<a href="#">SNJ54HC74W</a>	Active	Production	CFP (W)   14	25   TUBE	No	SNPB	N/A for Pkg Type	-55 to 125	8405601DA SNJ54HC74W
SNJ54HC74W.A	Active	Production	CFP (W)   14	25   TUBE	No	SNPB	N/A for Pkg Type	-55 to 125	8405601DA SNJ54HC74W

(1) **Status:** For more details on status, see our [product life cycle](#).

(2) **Material type:** When designated, preproduction parts are prototypes/experimental devices, and are not yet approved or released for full production. Testing and final process, including without limitation quality assurance, reliability performance testing, and/or process qualification, may not yet be complete, and this item is subject to further changes or possible discontinuation. If available for ordering, purchases will be subject to an additional waiver at checkout, and are intended for early internal evaluation purposes only. These items are sold without warranties of any kind.

(3) **RoHS values:** Yes, No, RoHS Exempt. See the [TI RoHS Statement](#) for additional information and value definition.

(4) **Lead finish/Ball material:** Parts may have multiple material finish options. Finish options are separated by a vertical ruled line. Lead finish/Ball material values may wrap to two lines if the finish value exceeds the maximum column width.

(5) **MSL rating/Peak reflow:** The moisture sensitivity level ratings and peak solder (reflow) temperatures. In the event that a part has multiple moisture sensitivity ratings, only the lowest level per JEDEC standards is shown. Refer to the shipping label for the actual reflow temperature that will be used to mount the part to the printed circuit board.

(6) **Part marking:** There may be an additional marking, which relates to the logo, the lot trace code information, or the environmental category of the part.

Multiple part markings will be inside parentheses. Only one part marking contained in parentheses and separated by a "~" will appear on a part. If a line is indented then it is a continuation of the previous line and the two combined represent the entire part marking for that device.

**Important Information and Disclaimer:** The information provided on this page represents TI's knowledge and belief as of the date that it is provided. TI bases its knowledge and belief on information provided by third parties, and makes no representation or warranty as to the accuracy of such information. Efforts are underway to better integrate information from third parties. TI has taken and continues to take reasonable steps to provide representative and accurate information but may not have conducted destructive testing or chemical analysis on incoming materials and chemicals. TI and TI suppliers consider certain information to be proprietary, and thus CAS numbers and other limited information may not be available for release.

In no event shall TI's liability arising out of such information exceed the total purchase price of the TI part(s) at issue in this document sold by TI to Customer on an annual basis.

**OTHER QUALIFIED VERSIONS OF SN54HC74, SN54HC74-SP, SN74HC74 :**

- Catalog : [SN74HC74](#), [SN54HC74](#)
  
- Automotive : [SN74HC74-Q1](#), [SN74HC74-Q1](#)
  
- Enhanced Product : [SN74HC74-EP](#), [SN74HC74-EP](#)
  
- Military : [SN54HC74](#)
  
- Space : [SN54HC74-SP](#)

NOTE: Qualified Version Definitions:

- Catalog - TI's standard catalog product
  
- Automotive - Q100 devices qualified for high-reliability automotive applications targeting zero defects
  
- Enhanced Product - Supports Defense, Aerospace and Medical Applications
  
- Military - QML certified for Military and Defense Applications
  
- Space - Radiation tolerant, ceramic packaging and qualified for use in Space-based application

**TAPE AND REEL INFORMATION**

**QUADRANT ASSIGNMENTS FOR PIN 1 ORIENTATION IN TAPE**

\*All dimensions are nominal

Device	Package Type	Package Drawing	Pins	SPQ	Reel Diameter (mm)	Reel Width W1 (mm)	A0 (mm)	B0 (mm)	K0 (mm)	P1 (mm)	W (mm)	Pin1 Quadrant
SN74HC74DBR	SSOP	DB	14	2000	330.0	16.4	8.35	6.6	2.4	12.0	16.0	Q1
SN74HC74DR	SOIC	D	14	2500	330.0	16.4	6.5	9.0	2.1	8.0	16.0	Q1
SN74HC74DR	SOIC	D	14	2500	330.0	16.4	6.5	9.0	2.1	8.0	16.0	Q1
SN74HC74DRG4	SOIC	D	14	2500	330.0	16.4	6.5	9.0	2.1	8.0	16.0	Q1
SN74HC74NSR	SOP	NS	14	2000	330.0	16.4	8.45	10.55	2.5	12.0	16.2	Q1
SN74HC74NSRG4	SOP	NS	14	2000	330.0	16.4	8.45	10.55	2.5	12.0	16.2	Q1
SN74HC74PWR	TSSOP	PW	14	2000	330.0	12.4	6.9	5.6	1.6	8.0	12.0	Q1
SN74HC74PWR1G4	TSSOP	PW	14	2000	330.0	12.4	6.9	5.6	1.6	8.0	12.0	Q1

**TAPE AND REEL BOX DIMENSIONS**

\*All dimensions are nominal

Device	Package Type	Package Drawing	Pins	SPQ	Length (mm)	Width (mm)	Height (mm)
SN74HC74DBR	SSOP	DB	14	2000	353.0	353.0	32.0
SN74HC74DR	SOIC	D	14	2500	340.5	336.1	32.0
SN74HC74DR	SOIC	D	14	2500	340.5	336.1	32.0
SN74HC74DRG4	SOIC	D	14	2500	340.5	336.1	32.0
SN74HC74NSR	SOP	NS	14	2000	353.0	353.0	32.0
SN74HC74NSRG4	SOP	NS	14	2000	353.0	353.0	32.0
SN74HC74PWR	TSSOP	PW	14	2000	356.0	356.0	35.0
SN74HC74PWR1G4	TSSOP	PW	14	2000	353.0	353.0	32.0

**TUBE**

\*All dimensions are nominal

Device	Package Name	Package Type	Pins	SPQ	L (mm)	W (mm)	T (µm)	B (mm)
5962-8405601VDA	W	CFP	14	25	506.98	26.16	6220	NA
5962-8405601VDA.A	W	CFP	14	25	506.98	26.16	6220	NA
84056012A	FK	LCCC	20	55	506.98	12.06	2030	NA
8405601DA	W	CFP	14	25	506.98	26.16	6220	NA
JM38510/65302B2A	FK	LCCC	20	55	506.98	12.06	2030	NA
JM38510/65302B2A.A	FK	LCCC	20	55	506.98	12.06	2030	NA
JM38510/65302BDA	W	CFP	14	25	506.98	26.16	6220	NA
JM38510/65302BDA.A	W	CFP	14	25	506.98	26.16	6220	NA
M38510/65302B2A	FK	LCCC	20	55	506.98	12.06	2030	NA
M38510/65302BDA	W	CFP	14	25	506.98	26.16	6220	NA
SN74HC74N	N	PDIP	14	25	506	13.97	11230	4.32
SN74HC74N	N	PDIP	14	25	506	13.97	11230	4.32
SN74HC74N.A	N	PDIP	14	25	506	13.97	11230	4.32
SN74HC74N.A	N	PDIP	14	25	506	13.97	11230	4.32
SN74HC74NE4	N	PDIP	14	25	506	13.97	11230	4.32
SN74HC74NE4	N	PDIP	14	25	506	13.97	11230	4.32
SNJ54HC74FK	FK	LCCC	20	55	506.98	12.06	2030	NA
SNJ54HC74FK.A	FK	LCCC	20	55	506.98	12.06	2030	NA
SNJ54HC74W	W	CFP	14	25	506.98	26.16	6220	NA
SNJ54HC74W.A	W	CFP	14	25	506.98	26.16	6220	NA



D0014A



# PACKAGE OUTLINE

SOIC - 1.75 mm max height

SMALL OUTLINE INTEGRATED CIRCUIT



4220718/A 09/2016

NOTES:

1. All linear dimensions are in millimeters. Dimensions in parenthesis are for reference only. Dimensioning and tolerancing per ASME Y14.5M.
2. This drawing is subject to change without notice.
3. This dimension does not include mold flash, protrusions, or gate burrs. Mold flash, protrusions, or gate burrs shall not exceed 0.15 mm, per side.
4. This dimension does not include interlead flash. Interlead flash shall not exceed 0.43 mm, per side.
5. Reference JEDEC registration MS-012, variation AB.

# EXAMPLE BOARD LAYOUT

D0014A

SOIC - 1.75 mm max height

SMALL OUTLINE INTEGRATED CIRCUIT



LAND PATTERN EXAMPLE  
SCALE:8X



SOLDER MASK DETAILS

4220718/A 09/2016

NOTES: (continued)

- 6. Publication IPC-7351 may have alternate designs.
- 7. Solder mask tolerances between and around signal pads can vary based on board fabrication site.

# EXAMPLE STENCIL DESIGN

D0014A

SOIC - 1.75 mm max height

SMALL OUTLINE INTEGRATED CIRCUIT



SOLDER PASTE EXAMPLE  
BASED ON 0.125 mm THICK STENCIL  
SCALE:8X

4220718/A 09/2016

NOTES: (continued)

8. Laser cutting apertures with trapezoidal walls and rounded corners may offer better paste release. IPC-7525 may have alternate design recommendations.
9. Board assembly site may have different recommendations for stencil design.

# MECHANICAL DATA

NS (R-PDSO-G\*\*)

PLASTIC SMALL-OUTLINE PACKAGE

14-PINS SHOWN



- NOTES:
- A. All linear dimensions are in millimeters.
  - B. This drawing is subject to change without notice.
  - C. Body dimensions do not include mold flash or protrusion, not to exceed 0,15.

W (R-GDFP-F14)

CERAMIC DUAL FLATPACK



- NOTES:
- A. All linear dimensions are in inches (millimeters).
  - B. This drawing is subject to change without notice.
  - C. This package can be hermetically sealed with a ceramic lid using glass frit.
  - D. Index point is provided on cap for terminal identification only.
  - E. Falls within MIL STD 1835 GDFP1-F14

# DB0014A

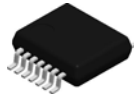

# PACKAGE OUTLINE

## SSOP - 2 mm max height

SMALL OUTLINE PACKAGE



### NOTES:

1. All linear dimensions are in millimeters. Any dimensions in parenthesis are for reference only. Dimensioning and tolerancing per ASME Y14.5M.
2. This drawing is subject to change without notice.
3. This dimension does not include mold flash, protrusions, or gate burrs. Mold flash, protrusions, or gate burrs shall not exceed 0.15 mm per side.
4. Reference JEDEC registration MO-150.

# EXAMPLE BOARD LAYOUT

DB0014A

SSOP - 2 mm max height

SMALL OUTLINE PACKAGE



LAND PATTERN EXAMPLE  
EXPOSED METAL SHOWN  
SCALE: 10X



4220762/A 05/2024

NOTES: (continued)

5. Publication IPC-7351 may have alternate designs.
6. Solder mask tolerances between and around signal pads can vary based on board fabrication site.

# EXAMPLE STENCIL DESIGN

DB0014A

SSOP - 2 mm max height

SMALL OUTLINE PACKAGE



SOLDER PASTE EXAMPLE  
BASED ON 0.125 mm THICK STENCIL  
SCALE: 10X

4220762/A 05/2024

NOTES: (continued)

7. Laser cutting apertures with trapezoidal walls and rounded corners may offer better paste release. IPC-7525 may have alternate design recommendations.
8. Board assembly site may have different recommendations for stencil design.



## GENERIC PACKAGE VIEW

**FK 20**

**LCCC - 2.03 mm max height**

8.89 x 8.89, 1.27 mm pitch

LEADLESS CERAMIC CHIP CARRIER

This image is a representation of the package family, actual package may vary.  
Refer to the product data sheet for package details.



4229370VA\

J 14

**GENERIC PACKAGE VIEW**  
**CDIP - 5.08 mm max height**  
CERAMIC DUAL IN LINE PACKAGE



Images above are just a representation of the package family, actual package may vary.  
Refer to the product data sheet for package details.

4040083-5/G



# EXAMPLE BOARD LAYOUT

J0014A

CDIP - 5.08 mm max height

CERAMIC DUAL IN LINE PACKAGE



LAND PATTERN EXAMPLE  
NON-SOLDER MASK DEFINED  
SCALE: 5X



4214771/A 05/2017

N (R-PDIP-T\*\*)

PLASTIC DUAL-IN-LINE PACKAGE

16 PINS SHOWN



- NOTES:
- A. All linear dimensions are in inches (millimeters).
  - B. This drawing is subject to change without notice.
  - $\triangle C$  Falls within JEDEC MS-001, except 18 and 20 pin minimum body length (Dim A).
  - $\triangle D$  The 20 pin end lead shoulder width is a vendor option, either half or full width.

4040049/E 12/2002

PW0014A



**PACKAGE OUTLINE**  
**TSSOP - 1.2 mm max height**

SMALL OUTLINE PACKAGE



4220202/B 12/2023

NOTES:

1. All linear dimensions are in millimeters. Any dimensions in parenthesis are for reference only. Dimensioning and tolerancing per ASME Y14.5M.
2. This drawing is subject to change without notice.
3. This dimension does not include mold flash, protrusions, or gate burrs. Mold flash, protrusions, or gate burrs shall not exceed 0.15 mm per side.
4. This dimension does not include interlead flash. Interlead flash shall not exceed 0.25 mm per side.
5. Reference JEDEC registration MO-153.

# EXAMPLE BOARD LAYOUT

PW0014A

TSSOP - 1.2 mm max height

SMALL OUTLINE PACKAGE



LAND PATTERN EXAMPLE  
EXPOSED METAL SHOWN  
SCALE: 10X



4220202/B 12/2023

NOTES: (continued)

- 6. Publication IPC-7351 may have alternate designs.
- 7. Solder mask tolerances between and around signal pads can vary based on board fabrication site.

# EXAMPLE STENCIL DESIGN

PW0014A

TSSOP - 1.2 mm max height

SMALL OUTLINE PACKAGE



SOLDER PASTE EXAMPLE  
BASED ON 0.125 mm THICK STENCIL  
SCALE: 10X

4220202/B 12/2023

NOTES: (continued)

8. Laser cutting apertures with trapezoidal walls and rounded corners may offer better paste release. IPC-7525 may have alternate design recommendations.
9. Board assembly site may have different recommendations for stencil design.



## 重要通知和免责声明

TI“按原样”提供技术和可靠性数据（包括数据表）、设计资源（包括参考设计）、应用或其他设计建议、网络工具、安全信息和其他资源，不保证没有瑕疵且不做任何明示或暗示的担保，包括但不限于对适销性、与某特定用途的适用性或不侵犯任何第三方知识产权的暗示担保。

这些资源可供使用 TI 产品进行设计的熟练开发人员使用。您将自行承担以下全部责任：(1) 针对您的应用选择合适的 TI 产品，(2) 设计、验证并测试您的应用，(3) 确保您的应用满足相应标准以及任何其他安全、安保法规或其他要求。

这些资源如有变更，恕不另行通知。TI 授权您仅可将这些资源用于研发本资源所述的 TI 产品的相关应用。严禁以其他方式对这些资源进行复制或展示。您无权使用任何其他 TI 知识产权或任何第三方知识产权。对于因您对这些资源的使用而对 TI 及其代表造成的任何索赔、损害、成本、损失和债务，您将全额赔偿，TI 对此概不负责。

TI 提供的产品受 [TI 销售条款](#)、[TI 通用质量指南](#) 或 [ti.com](#) 上其他适用条款或 TI 产品随附的其他适用条款的约束。TI 提供这些资源并不会扩展或以其他方式更改 TI 针对 TI 产品发布的适用的担保或担保免责声明。除非德州仪器 (TI) 明确将某产品指定为定制产品或客户特定产品，否则其产品均为按确定价格收入目录的标准通用器件。

TI 反对并拒绝您可能提出的任何其他或不同的条款。

版权所有 © 2025，德州仪器 (TI) 公司

最后更新日期：2025 年 10 月