

SN74LVC257A-Q1 具有三态输出的 汽车级四通道 2:1 数据选择器/多路复用器

1 特性

- 符合汽车应用要求
- ESD 保护性能超过 2000V
(根据 MIL-STD-883 方法 3015)
- 工作电压范围为 2V 至 3.6V
- 输入电压高达 5.5V
- 3.3V 时, t_{pd} 最大值为 4.6ns
- V_{OLP} (输出接地反弹) 典型值小于 0.8V ($V_{CC} = 3.3V$ 、 $T_A = 25^\circ C$ 时)
- V_{OHV} (输出 V_{OH} 下冲) 典型值大于 2V ($V_{CC} = 3.3V$ 、 $T_A = 25^\circ C$ 时)

2 说明

SN74LVC257A 四通道 2:1 数据选择器/多路复用器可在 2.7V 至 3.6V V_{CC} 下运行。

封装信息

器件型号	封装 ⁽¹⁾	封装尺寸 ⁽²⁾	本体尺寸 ⁽³⁾
SN74LVC257A-Q1	BQB (WQFN, 16)	3.5mm × 2.5mm	3.5mm × 2.5mm
	D (SOIC, 16)	9.90mm × 6mm	9.90mm × 3.90mm
	PW (TSSOP, 16)	5.00mm × 6.4mm	5.00mm × 4.40mm

- 如需了解更多信息, 请参阅机械、封装和可订购信息。
- 封装尺寸 (长 × 宽) 为标称值, 并包括引脚 (如适用)。
- 本体尺寸 (长 × 宽) 为标称值, 不包括引脚。

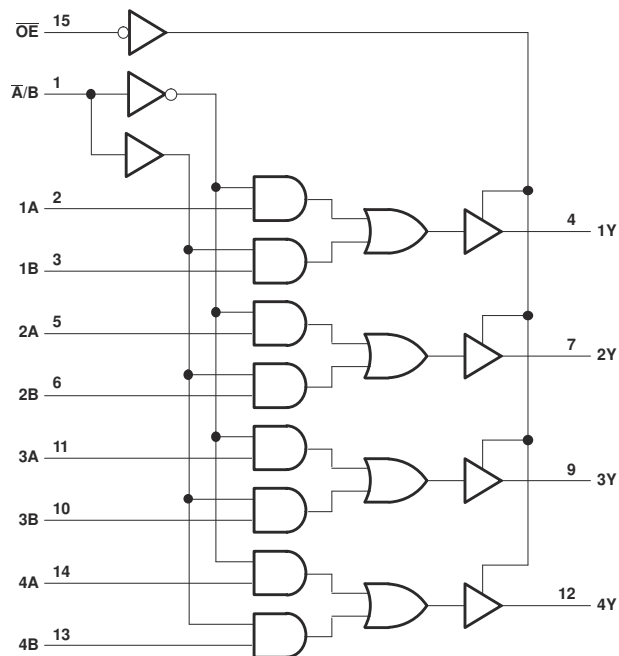

逻辑图 (正逻辑)



Table of Contents

1 特性	1	6.3 Device Functional Modes.....	8
2 说明	1	7 Application and Implementation	9
3 Pin Configuration and Functions	3	7.1 Power Supply Recommendations.....	9
4 Specifications	4	7.2 Layout.....	9
4.1 Absolute Maximum Ratings.....	4	8 Device and Documentation Support	10
4.2 ESD Ratings.....	4	8.1 Documentation Support (Analog).....	10
4.3 Recommended Operating Conditions.....	4	8.2 接收文档更新通知.....	10
4.4 Thermal Information.....	4	8.3 支持资源.....	10
4.5 Electrical Characteristics.....	5	8.4 Trademarks.....	10
4.6 Switching Characteristics.....	5	8.5 静电放电警告.....	10
4.7 Operating Characteristics.....	5	8.6 术语表.....	10
5 Parameter Measurement Information	6	9 Revision History	10
6 Detailed Description	7	10 Mechanical, Packaging, and Orderable Information	10
6.1 Overview.....	7		
6.2 Functional Block Diagram.....	7		

3 Pin Configuration and Functions



图 3-1. D or PW Package, 16-Pin SOIC or TSSOP (Top View)



图 3-2. BQB Package, 16-Pin WQFN with Exposed Thermal Pad (Top View)

表 3-1. Pin Functions

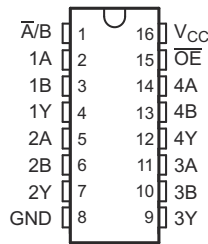
PIN		I/O	DESCRIPTION
NAME	SOIC, TSSOP, or WQFN		
A/B	1	I	Select Pin, Low selects A, High selects B
1A	2	I/O	Multiplexer Signal Input
1B	3	I/O	Multiplexer Signal Input
1Y	4	I/O	Multiplexer Output
2A	5	I/O	Multiplexer Signal Input
2B	6	I/O	Multiplexer Signal Input
2Y	7	I/O	Multiplexer Output
3A	11	I/O	Multiplexer Signal Input
3B	10	I/O	Multiplexer Signal Input
3Y	9	I/O	Multiplexer Output
4A	14	I/O	Multiplexer Signal Input
4B	13	I/O	Multiplexer Signal Input
4Y	12	I/O	Multiplexer Output
GND	8	—	Ground
NC ⁽¹⁾	—	—	No connect
OE	15	I/O	Active low Output enable
V _{CC}	16	—	Power pin

(1) NC - no internal connection

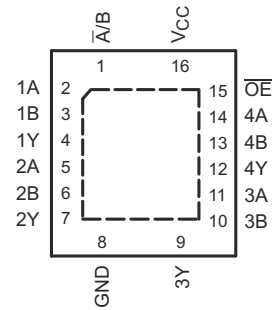
4 Specifications

4.1 Absolute Maximum Ratings

over operating free-air temperature range (unless otherwise noted)

		MIN	MAX	UNIT
V_{CC}	Supply voltage range	- 0.5	6.5	V
V_I	Input voltage range ⁽¹⁾	- 0.5	6.5	V
V_O	Output voltage range ^{(1) (2)}	- 0.5	$V_{CC} + 0.5$	V
I_{IK}	Input clamp current	$V_I < 0$	- 50	mA
I_{OK}	Output clamp current	$V_O < 0$	- 50	mA
I_O	Continuous output current		±50	mA
	Continuous current through V_{CC} or GND		±100	mA
T_{stg}	Storage temperature range	- 65	150	°C

- (1) The input and output negative-voltage ratings may be exceeded if the input and output current ratings are observed.
(2) The value of V_{CC} is provided in the recommended operating conditions table.

4.2 ESD Ratings

			VALUE	UNIT
$V_{(ESD)}$	Electrostatic discharge	Human body model (HBM), per ANSI/ESDA/JEDEC JS-001, all pins ⁽¹⁾	±2000	V

- (1) JEDEC document JEP155 states that 500-V HBM allows safe manufacturing with a standard ESD control process.

4.3 Recommended Operating Conditions

over recommended operating free-air temperature range (unless otherwise noted)

		MIN	MAX	UNIT	
V_{CC}	Supply voltage	Operating	2	3.6	V
		Data retention only	1.5		
V_{IH}	High-level input voltage	$V_{CC} = 2.7\text{ V to }3.6\text{ V}$		V	
V_{IL}	Low-level input voltage	$V_{CC} = 2.7\text{ V to }3.6\text{ V}$		V	
V_I	Input voltage	0	5.5	V	
V_O	Output voltage	0	V_{CC}	V	
I_{OH}	High-level output current	$V_{CC} = 2.7\text{ V}$	- 12	mA	
		$V_{CC} = 3\text{ V}$	- 24		
I_{OL}	Low-level output current	$V_{CC} = 2.7\text{ V}$	12	mA	
		$V_{CC} = 3\text{ V}$	24		
$\Delta t / \Delta v$	Input transition rise or fall rate		10	ns/V	
T_A	Operating free-air temperature	- 40	125	°C	

4.4 Thermal Information

THERMAL METRIC ⁽¹⁾	SN74LVC257A-Q1			UNIT	
	BQB (WQFN)	D (SOIC)	PW (TSSOP)		
	16 PINS				
$R_{\theta JA}$	Junction-to-ambient thermal resistance	98.8	73	108	°C/W

- (1) For more information about traditional and new thermal metrics, see the *Semiconductor and IC Package Thermal Metrics* application report, [SPRA953](#).

4.5 Electrical Characteristics

over recommended operating free-air temperature range (unless otherwise noted)

PARAMETER	TEST CONDITIONS	V _{CC}	MIN	TYP ⁽¹⁾	MAX	UNIT
V _{OH}	I _{OH} = - 100 μA	2.7 V to 3.6 V	V _{CC} - 0.2		V	
	I _{OH} = - 12 mA	2.7 V	2.2			
		3 V	2.4			
	I _{OH} = - 24 mA	3 V	2.2			
V _{OL}	I _{OL} = 100 μA	2.7 V to 3.6 V			0.2	V
	I _{OL} = 12 mA	2.7 V			0.4	
	I _{OL} = 24 mA	3 V			0.55	
I _I	V _I = 5.5 V or GND	3.6 V			±5	μA
I _{OZ}	V _O = V _{CC} or GND	3.6 V			±15	μA
I _{CC}	V _I = V _{CC} or GND, I _O = 0	3.6 V			10	μA
Δ I _{CC}	One input at V _{CC} - 0.6 V, Other inputs at V _{CC} or GND	2.7 V to 3.6 V			500	μA
C _i	V _I = V _{CC} or GND	3.3 V			5	pF
C _o	V _O = V _{CC} or GND	3.3 V			5	pF

(1) All typical values are at V_{CC} = 3.3 V, T_A = 25°C.

4.6 Switching Characteristics

over recommended operating free-air temperature range (unless otherwise noted) (see [Load Circuit and Voltage Waveforms](#))

PARAMETER	FROM (INPUT)	TO (OUTPUT)	V _{CC} = 2.7 V		V _{CC} = 3.3 V ± 0.3 V		UNIT
			MIN	MAX	MIN	MAX	
t _{pd}	A or B	Y	5.4		1	4.6	ns
	\bar{A}/\bar{B}		7.5		1	6.4	
t _{en}	\overline{OE}	Y	6.7		1	5.6	ns
t _{dis}	\overline{OE}	Y	4.7		0.5	4.3	ns
t _{sk(o)}					1		ns

4.7 Operating Characteristics

T_A = 25°C

PARAMETER	TEST CONDITIONS	V _{CC} = 2.5 V	V _{CC} = 3.3 V	UNIT
		TYP	TYP	
C _{pd} Power dissipation capacitance	f = 10 MHz	14.5	15.5	pF

5 Parameter Measurement Information

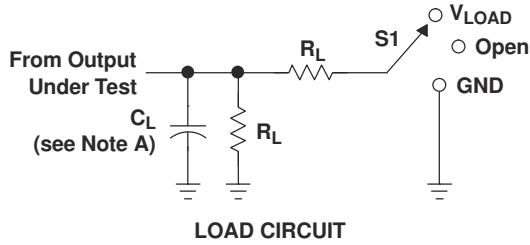

TEST	S1
t_{PLH}/t_{PHL}	Open
t_{PLZ}/t_{PZL}	V_{LOAD}
t_{PHZ}/t_{PZH}	GND

V_{CC}	INPUTS		V_M	V_{LOAD}	C_L	R_L	V_{Δ}
	V_I	t_r/t_f					
2.7 V	2.7 V	≤ 2.5 ns	1.5 V	6 V	50 pF	500 Ω	0.3 V
3.3 V \pm 0.3 V	2.7 V	≤ 2.5 ns	1.5 V	6 V	50 pF	500 Ω	0.3 V

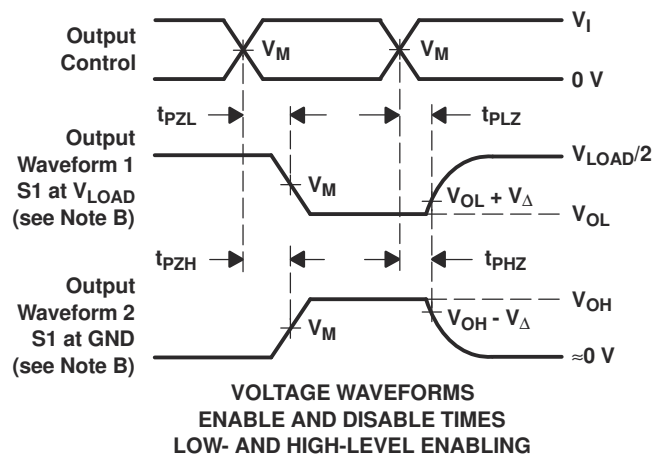
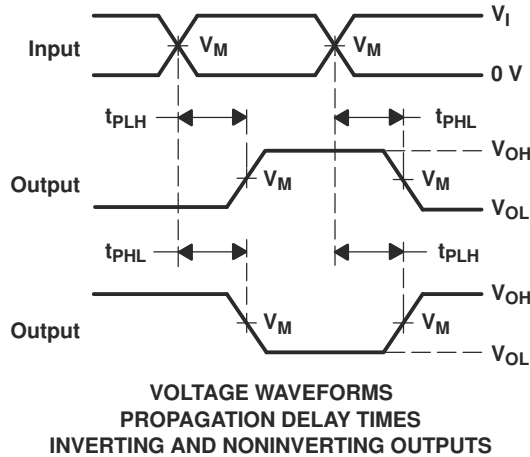
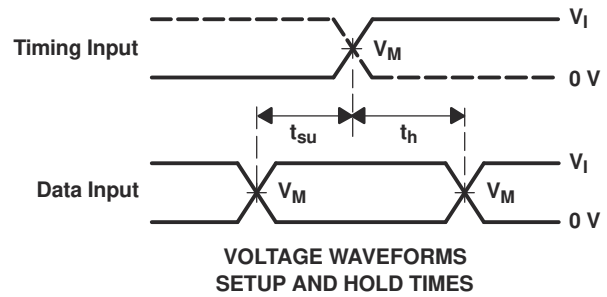
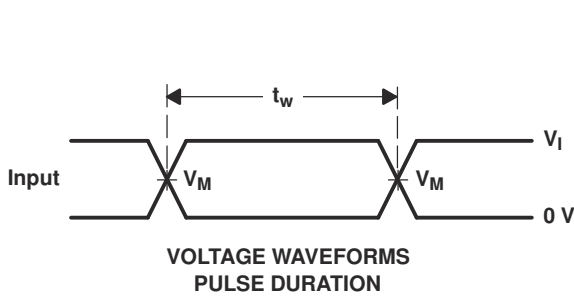

- NOTES:
- A. C_L includes probe and jig capacitance.
 - B. Waveform 1 is for an output with internal conditions such that the output is low, except when disabled by the output control. Waveform 2 is for an output with internal conditions such that the output is high, except when disabled by the output control.
 - C. All input pulses are supplied by generators having the following characteristics: PRR \leq 10 MHz, $Z_O = 50 \Omega$.
 - D. The outputs are measured one at a time, with one transition per measurement.
 - E. t_{PLZ} and t_{PHZ} are the same as t_{dis} .
 - F. t_{PZL} and t_{PZH} are the same as t_{en} .
 - G. t_{PLH} and t_{PHL} are the same as t_{pd} .
 - H. All parameters and waveforms are not applicable to all devices.

图 5-1. Load Circuit and Voltage Waveforms

6 Detailed Description

6.1 Overview

The device is designed to multiplex signals from 4-bit data sources to 4-output data lines in bus-organized systems. The 3-state outputs do not load the data lines when the output-enable (\overline{OE}) input is at a high logic level.

Inputs can be driven from either 3.3V or 5V devices. This feature allows the use of this device as a translator in a mixed 3.3V/5V system environment.

To ensure the high-impedance state during power up or power down, \overline{OE} should be tied to V_{CC} through a pullup resistor; the minimum value of the resistor is determined by the current-sinking capability of the driver.

6.2 Functional Block Diagram



图 6-1. Logic Diagram (Positive Logic)

6.3 Device Functional Modes

[Function Table](#) lists the functional modes for the SN74LVC257A-Q1 devices.

Function Table

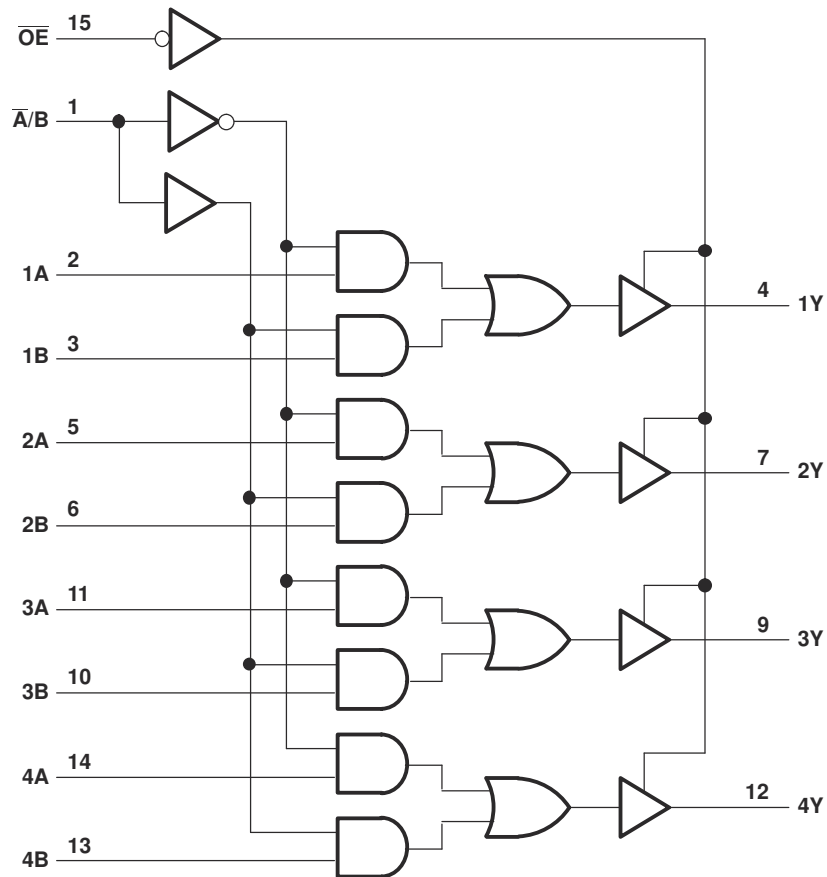
INPUTS				OUTPUT Y
OE	\bar{A}/B	A	B	
H	X	X	X	Z
L	L	L	X	L
L	L	H	X	H
L	H	X	L	L
L	H	X	H	H

7 Application and Implementation

备注

以下应用部分中的信息不属于 TI 器件规格的范围，TI 不担保其准确性和完整性。TI 的客户应负责确定器件是否适用于其应用。客户应验证并测试其设计，以确保系统功能。

7.1 Power Supply Recommendations

The power supply can be any voltage between the minimum and maximum supply voltage rating located in the [节 4.3](#) table.

Each V_{CC} terminal must have a good bypass capacitor to prevent power disturbance. For devices with a single supply, a 0.1- μ F capacitor is recommended. If there are multiple V_{CC} terminals then 0.01- μ F or 0.022- μ F capacitors are recommended for each power terminal. It is ok to parallel multiple bypass capacitors to reject different frequencies of noise. Multiple bypass capacitors may be paralleled to reject different frequencies of noise. The bypass capacitor must be installed as close to the power terminal as possible for the best results.

7.2 Layout

7.2.1 Layout Guidelines

When using multiple bit logic devices, inputs must not float. In many cases, functions or parts of functions of digital logic devices are unused. Some examples are when only two inputs of a triple-input AND gate are used, or when only 3 of the 4-buffer gates are used. Such input pins must not be left unconnected because the undefined voltages at the outside connections result in undefined operational states.

Specified in [Layout Example for the SN74LVC257A-Q1](#) are rules that must be observed under all circumstances. All unused inputs of digital logic devices must be connected to a high or low bias to prevent them from floating. The logic level that must be applied to any particular unused input depends on the function of the device. Generally they will be tied to GND or V_{CC} , whichever makes more sense or is more convenient.

7.2.2 Layout Example



图 7-1. Example Layout for the SN74LVC257A-Q1

8 Device and Documentation Support

8.1 Documentation Support (Analog)

8.1.1 Related Links

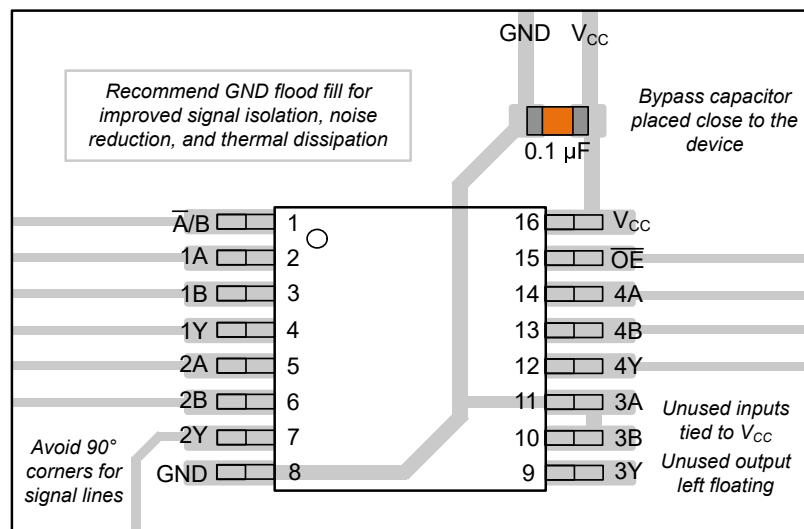
The table below lists quick access links. Categories include technical documents, support and community resources, tools and software, and quick access to sample or buy.

表 8-1. Related Links

PARTS	PRODUCT FOLDER	SAMPLE & BUY	TECHNICAL DOCUMENTS	TOOLS & SOFTWARE	SUPPORT & COMMUNITY
SN74LVC257A-Q1	Click here	Click here	Click here	Click here	Click here

8.2 接收文档更新通知

要接收文档更新通知，请导航至 [ti.com](#) 上的器件产品文件夹。点击 [通知](#) 进行注册，即可每周接收产品信息更改摘要。有关更改的详细信息，请查看任何已修订文档中包含的修订历史记录。

8.3 支持资源

[TI E2E™ 中文支持论坛](#) 是工程师的重要参考资料，可直接从专家处获得快速、经过验证的解答和设计帮助。搜索现有解答或提出自己的问题，获得所需的快速设计帮助。

链接的内容由各个贡献者“按原样”提供。这些内容并不构成 TI 技术规范，并且不一定反映 TI 的观点；请参阅 TI 的 [使用条款](#)。

8.4 Trademarks

TI E2E™ is a trademark of Texas Instruments.

所有商标均为其各自所有者的财产。

8.5 静电放电警告



静电放电 (ESD) 会损坏这个集成电路。德州仪器 (TI) 建议通过适当的预防措施处理所有集成电路。如果不遵守正确的处理和安装程序，可能会损坏集成电路。

ESD 的损坏小至导致微小的性能降级，大至整个器件故障。精密的集成电路可能更容易受到损坏，这是因为非常细微的参数更改都可能会导致器件与其发布的规格不相符。

8.6 术语表

[TI 术语表](#) 本术语表列出并解释了术语、首字母缩略词和定义。

9 Revision History

注：以前版本的页码可能与当前版本的页码不同

Changes from Revision B (February 2008) to Revision C (May 2024)	Page
• 向封装信息表、引脚配置和功能部分以及热性能信息表中添加了 BQA 封装.....	1
• 添加了封装信息表、引脚功能表、ESD 等级表、热性能信息表、器件功能模式、“应用和实施”部分、器件和文档支持部分以及机械、封装和可订购信息部分.....	1
• 删除了整个数据表中对机器放电模型的引用.....	1

10 Mechanical, Packaging, and Orderable Information

The following pages include mechanical, packaging, and orderable information. This information is the most current data available for the designated devices. This data is subject to change without notice and revision of this document. For browser-based versions of this data sheet, refer to the left-hand navigation.

PACKAGING INFORMATION

Orderable Device	Status (1)	Package Type	Package Drawing	Pins	Package Qty	Eco Plan (2)	Lead finish/ Ball material (6)	MSL Peak Temp (3)	Op Temp (°C)	Device Marking (4/5)	Samples
CLVC257AQPWRG4Q1	ACTIVE	TSSOP	PW	16	2000	RoHS & Green	NIPDAU	Level-1-260C-UNLIM	-40 to 125	L257AQ1	Samples
SN74LVC257APWRQ1	ACTIVE	TSSOP	PW	16	3000	RoHS & Green	NIPDAU	Level-1-260C-UNLIM	-40 to 125	LVC257Q	Samples
SN74LVC257AQDRG4Q1	ACTIVE	SOIC	D	16	2500	RoHS & Green	NIPDAU	Level-1-260C-UNLIM	-40 to 125	L257AQ1	Samples
SN74LVC257AWBQBRQ1	ACTIVE	WQFN	BQB	16	3000	RoHS & Green	NIPDAU	Level-1-260C-UNLIM	-40 to 125	LC257Q	Samples

(1) The marketing status values are defined as follows:

ACTIVE: Product device recommended for new designs.

LIFEBUY: TI has announced that the device will be discontinued, and a lifetime-buy period is in effect.

NRND: Not recommended for new designs. Device is in production to support existing customers, but TI does not recommend using this part in a new design.

PREVIEW: Device has been announced but is not in production. Samples may or may not be available.

OBSELETE: TI has discontinued the production of the device.

(2) **RoHS:** TI defines "RoHS" to mean semiconductor products that are compliant with the current EU RoHS requirements for all 10 RoHS substances, including the requirement that RoHS substance do not exceed 0.1% by weight in homogeneous materials. Where designed to be soldered at high temperatures, "RoHS" products are suitable for use in specified lead-free processes. TI may reference these types of products as "Pb-Free".

RoHS Exempt: TI defines "RoHS Exempt" to mean products that contain lead but are compliant with EU RoHS pursuant to a specific EU RoHS exemption.

Green: TI defines "Green" to mean the content of Chlorine (Cl) and Bromine (Br) based flame retardants meet JS709B low halogen requirements of <=1000ppm threshold. Antimony trioxide based flame retardants must also meet the <=1000ppm threshold requirement.

(3) MSL, Peak Temp. - The Moisture Sensitivity Level rating according to the JEDEC industry standard classifications, and peak solder temperature.

(4) There may be additional marking, which relates to the logo, the lot trace code information, or the environmental category on the device.

(5) Multiple Device Markings will be inside parentheses. Only one Device Marking contained in parentheses and separated by a "-" will appear on a device. If a line is indented then it is a continuation of the previous line and the two combined represent the entire Device Marking for that device.

(6) Lead finish/Ball material - Orderable Devices may have multiple material finish options. Finish options are separated by a vertical ruled line. Lead finish/Ball material values may wrap to two lines if the finish value exceeds the maximum column width.

Important Information and Disclaimer:The information provided on this page represents TI's knowledge and belief as of the date that it is provided. TI bases its knowledge and belief on information provided by third parties, and makes no representation or warranty as to the accuracy of such information. Efforts are underway to better integrate information from third parties. TI has taken and

continues to take reasonable steps to provide representative and accurate information but may not have conducted destructive testing or chemical analysis on incoming materials and chemicals. TI and TI suppliers consider certain information to be proprietary, and thus CAS numbers and other limited information may not be available for release.

In no event shall TI's liability arising out of such information exceed the total purchase price of the TI part(s) at issue in this document sold by TI to Customer on an annual basis.

OTHER QUALIFIED VERSIONS OF SN74LVC257A-Q1 :

- Catalog : [SN74LVC257A](#)
- Enhanced Product : [SN74LVC257A-EP](#)
- Military : [SN54LVC257A](#)

NOTE: Qualified Version Definitions:

- Catalog - TI's standard catalog product
- Enhanced Product - Supports Defense, Aerospace and Medical Applications
- Military - QML certified for Military and Defense Applications

TAPE AND REEL INFORMATION

QUADRANT ASSIGNMENTS FOR PIN 1 ORIENTATION IN TAPE

*All dimensions are nominal

Device	Package Type	Package Drawing	Pins	SPQ	Reel Diameter (mm)	Reel Width W1 (mm)	A0 (mm)	B0 (mm)	K0 (mm)	P1 (mm)	W (mm)	Pin1 Quadrant
CLVC257AQPWRG4Q1	TSSOP	PW	16	2000	330.0	12.4	6.9	5.6	1.6	8.0	12.0	Q1
SN74LVC257APWRQ1	TSSOP	PW	16	3000	330.0	12.4	6.9	5.6	1.6	8.0	12.0	Q1
SN74LVC257AWBQBRQ1	WQFN	BQB	16	3000	180.0	12.4	2.8	3.8	1.2	4.0	12.0	Q1

TAPE AND REEL BOX DIMENSIONS

*All dimensions are nominal

Device	Package Type	Package Drawing	Pins	SPQ	Length (mm)	Width (mm)	Height (mm)
CLVC257AQPWRG4Q1	TSSOP	PW	16	2000	356.0	356.0	35.0
SN74LVC257APWRQ1	TSSOP	PW	16	3000	353.0	353.0	32.0
SN74LVC257AWBQBRQ1	WQFN	BQB	16	3000	210.0	185.0	35.0

D (R-PDSO-G16)

PLASTIC SMALL OUTLINE



- NOTES:
- A. All linear dimensions are in inches (millimeters).
 - B. This drawing is subject to change without notice.
 - C. Body length does not include mold flash, protrusions, or gate burrs. Mold flash, protrusions, or gate burrs shall not exceed 0.006 (0,15) each side.
 - D. Body width does not include interlead flash. Interlead flash shall not exceed 0.017 (0,43) each side.
 - E. Reference JEDEC MS-012 variation AC.



4220204/A 02/2017

NOTES:

1. All linear dimensions are in millimeters. Any dimensions in parenthesis are for reference only. Dimensioning and tolerancing per ASME Y14.5M.
2. This drawing is subject to change without notice.
3. This dimension does not include mold flash, protrusions, or gate burrs. Mold flash, protrusions, or gate burrs shall not exceed 0.15 mm per side.
4. This dimension does not include interlead flash. Interlead flash shall not exceed 0.25 mm per side.
5. Reference JEDEC registration MO-153.

EXAMPLE BOARD LAYOUT

PW0016A

TSSOP - 1.2 mm max height

SMALL OUTLINE PACKAGE



LAND PATTERN EXAMPLE
EXPOSED METAL SHOWN
SCALE: 10X



SOLDER MASK DETAILS

4220204/A 02/2017

NOTES: (continued)

- 6. Publication IPC-7351 may have alternate designs.
- 7. Solder mask tolerances between and around signal pads can vary based on board fabrication site.

EXAMPLE STENCIL DESIGN

PW0016A

TSSOP - 1.2 mm max height

SMALL OUTLINE PACKAGE



SOLDER PASTE EXAMPLE
BASED ON 0.125 mm THICK STENCIL
SCALE: 10X

4220204/A 02/2017

NOTES: (continued)

8. Laser cutting apertures with trapezoidal walls and rounded corners may offer better paste release. IPC-7525 may have alternate design recommendations.
9. Board assembly site may have different recommendations for stencil design.

GENERIC PACKAGE VIEW

BQB 16

WQFN - 0.8 mm max height

2.5 x 3.5, 0.5 mm pitch

PLASTIC QUAD FLATPACK - NO LEAD

This image is a representation of the package family, actual package may vary.
Refer to the product data sheet for package details.

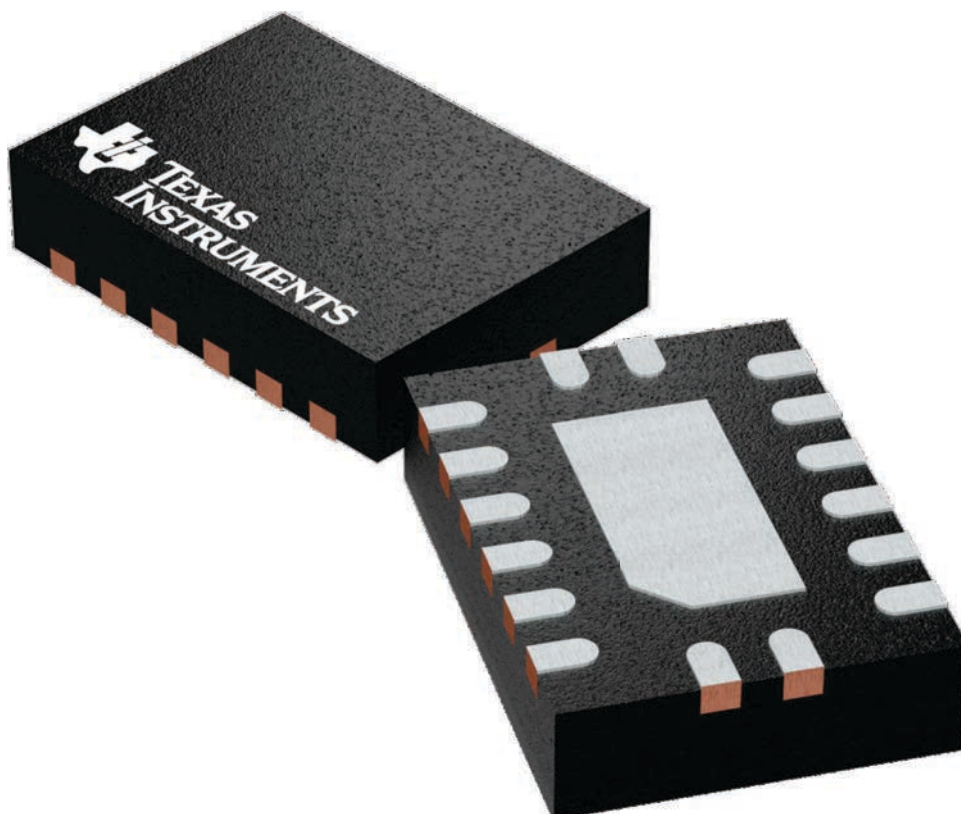

4226161/A

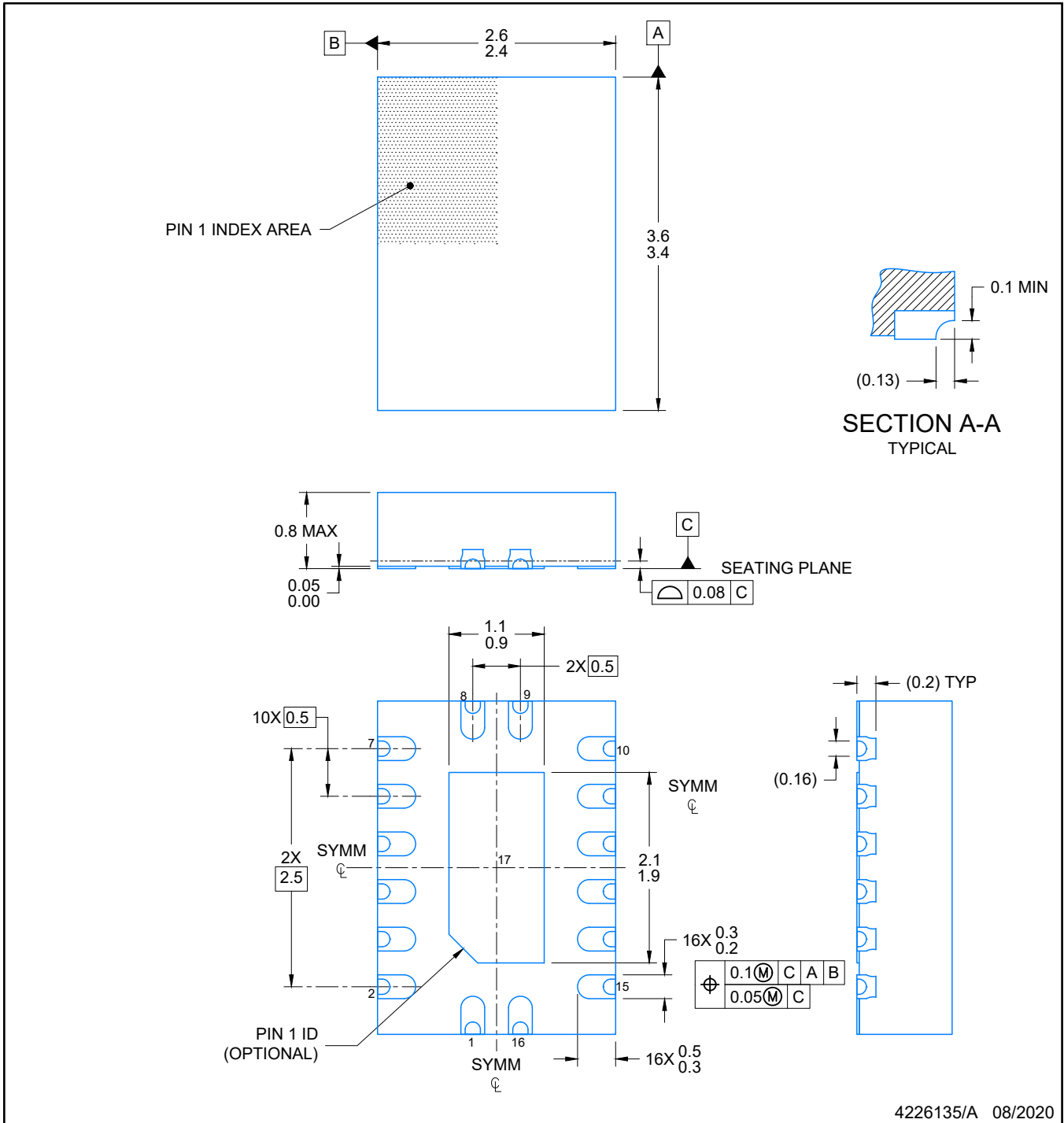

4226135/A 08/2020

NOTES:

1. All linear dimensions are in millimeters. Any dimensions in parenthesis are for reference only. Dimensioning and tolerancing per ASME Y14.5M.
2. This drawing is subject to change without notice.
3. The package thermal pad must be soldered to the printed circuit board for optimal thermal and mechanical performance.

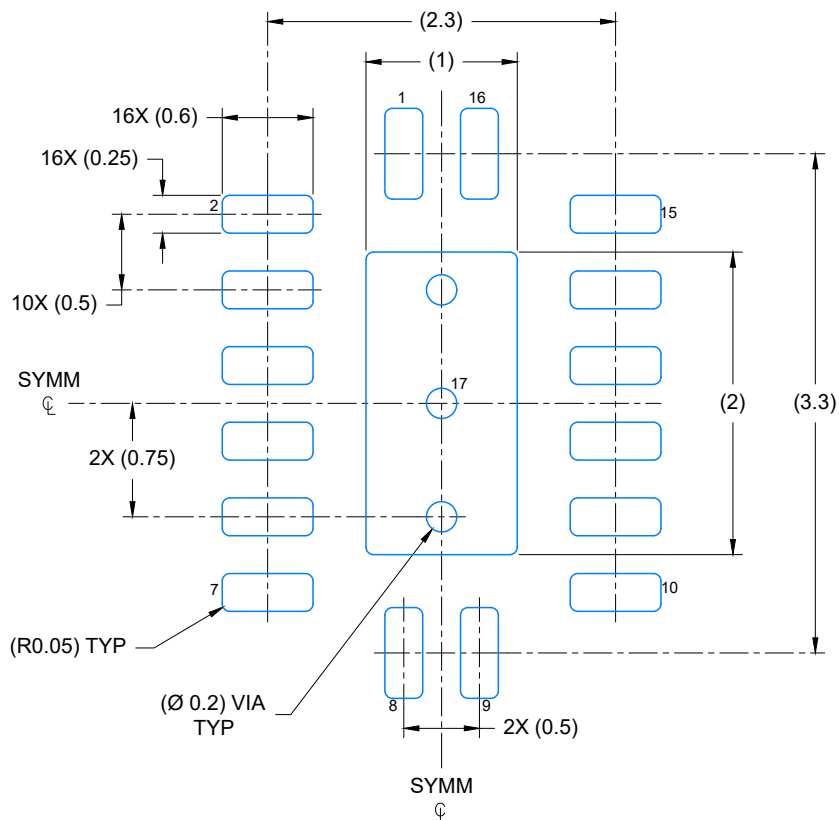

LAND PATTERN EXAMPLE
EXPOSED METAL SHOWN
SCALE: 20X

4226135/A 08/2020

NOTES: (continued)

4. This package is designed to be soldered to a thermal pad on the board. For more information, see Texas Instruments literature number SLUA271 (www.ti.com/lit/sluea271).
5. Vias are optional depending on application, refer to device data sheet. If any vias are implemented, refer to their locations shown on this view. It is recommended that vias under paste be filled, plugged or tented.

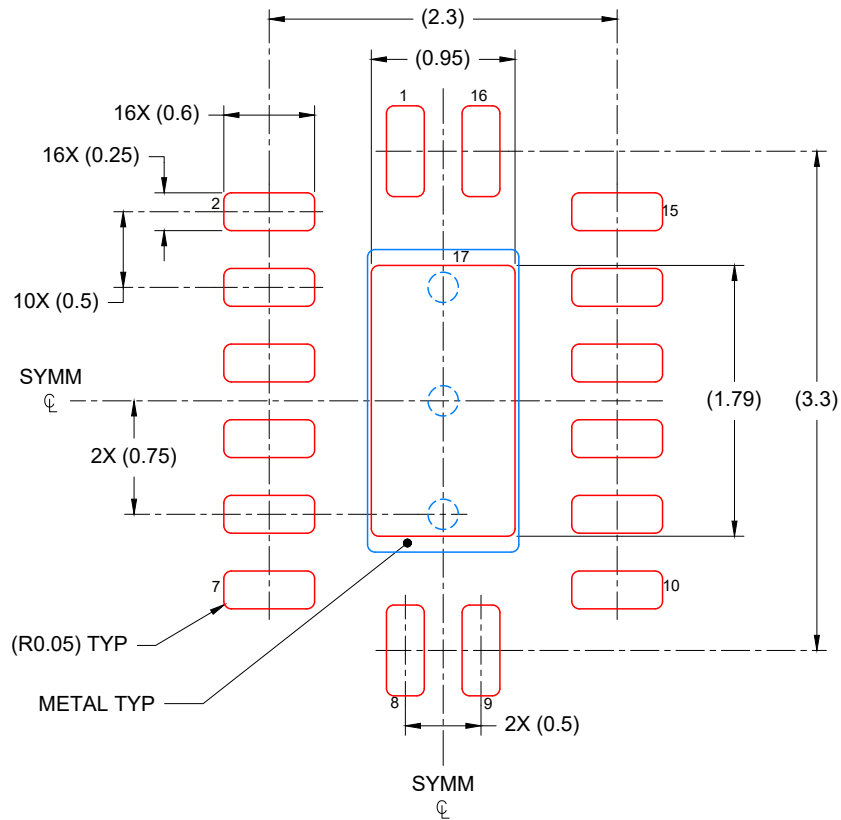

SOLDER PASTE EXAMPLE
 BASED ON 0.125 mm THICK STENCIL

EXPOSED PAD
 85% PRINTED COVERAGE BY AREA
 SCALE: 20X

4226135/A 08/2020

NOTES: (continued)

6. Laser cutting apertures with trapezoidal walls and rounded corners may offer better paste release. IPC-7525 may have alternate design recommendations.

重要声明和免责声明

TI“按原样”提供技术和可靠性数据（包括数据表）、设计资源（包括参考设计）、应用或其他设计建议、网络工具、安全信息和其他资源，不保证没有瑕疵且不做任何明示或暗示的担保，包括但不限于对适销性、某特定用途方面的适用性或不侵犯任何第三方知识产权的暗示担保。

这些资源可供使用 TI 产品进行设计的熟练开发人员使用。您将自行承担以下全部责任：(1) 针对您的应用选择合适的 TI 产品，(2) 设计、验证并测试您的应用，(3) 确保您的应用满足相应标准以及任何其他功能安全、信息安全、监管或其他要求。

这些资源如有变更，恕不另行通知。TI 授权您仅可将这些资源用于研发本资源所述的 TI 产品的应用。严禁对这些资源进行其他复制或展示。您无权使用任何其他 TI 知识产权或任何第三方知识产权。您应全额赔偿因在这些资源的使用中对 TI 及其代表造成的任何索赔、损害、成本、损失和债务，TI 对此概不负责。

TI 提供的产品受 [TI 的销售条款](#) 或 [ti.com](#) 上其他适用条款/TI 产品随附的其他适用条款的约束。TI 提供这些资源并不会扩展或以其他方式更改 TI 针对 TI 产品发布的适用的担保或担保免责声明。

TI 反对并拒绝您可能提出的任何其他或不同的条款。

邮寄地址：Texas Instruments, Post Office Box 655303, Dallas, Texas 75265

Copyright © 2024，德州仪器 (TI) 公司