

## TCAN1046A-Q1 具有待机模式的汽车类双路 CAN FD 收发器

### 1 特性

- AEC-Q100 (等级 1) : 符合汽车应用要求
- 两个具有模式控制功能的独立高速 CAN FD 收发器
- 符合 ISO 11898-2:2016 物理层标准要求
- 提供功能安全
  - 可帮助进行功能安全系统设计的文档
- 支持传统 CAN 和经优化的 CAN FD 性能 (数据速率为 2、5 和 8Mbps)
  - 具有较短的对称传播延迟时间, 可增加时序裕量
- 支持 12V 和 24V 电池应用
- 接收器共模输入电压:  $\pm 12V$
- 保护特性:
  - 总线故障保护:  $\pm 58V$
  - 欠压保护
  - TXD 显性超时 (DTO)
    - 数据速率低至 9.2kbps
  - 热关断保护 (TSD)
- 工作模式:
  - 正常模式
  - 支持远程唤醒请求功能的低功耗待机模式
- 优化了未上电时的性能
  - 总线和逻辑引脚为高阻抗 (运行总线或应用上无负载)
  - 支持热插拔: 在总线和 RXD 输出上可实现上电和断电无干扰运行
- 结温范围:  $-40^{\circ}C$  至  $150^{\circ}C$
- 采用 SOIC (14) 封装和无引线 VSON (14) 封装 (4.5mm x 3.0mm), 具有改进的自动光学检查 (AOI) 功能

### 2 应用

- 汽车和运输
  - 车身控制模块
  - 汽车网关
  - 高级驾驶辅助系统 (ADAS)
  - 信息娱乐系统

### 3 说明

TCAN1046A-Q1 是一款双路高速控制器局域网 (CAN) 收发器, 符合 ISO 11898-2:2016 高速 CAN 规范的物理层要求。

该器件支持传统 CAN 和 CAN FD 网络 (数据速率高达 8 兆位/秒 (Mbps))。此外, 该器件具有两个带独立电源 ( $V_{CC1}$  和  $V_{CC2}$ ) 和模式控制引脚 (STB1 和 STB2) 的 CAN FD 通道, 允许每个 CAN 通道真正地运行。在需要冗余或额外 CAN FD 通道作为系统故障时的备份的应用中, 能够独立操作每个通道的能力非常重要。

该器件具有很多保护和诊断功能, 包括热关断 (TSD)、TXD 显性超时 (DTO) 和高达  $\pm 58V$  的总线故障保护, 并且定义了电源欠压或引脚悬空情况下的失效防护行为。

#### 器件信息

器件型号	封装 <sup>(1)</sup>	封装尺寸 (标称值)
TCAN1046A-Q1	VSON (DMT) (14)	4.50mm x 3.00mm
	SOIC (D) (14)	8.95mm x 3.91mm

(1) 如需了解所有可用封装, 请参阅数据表末尾的可订购产品附录。

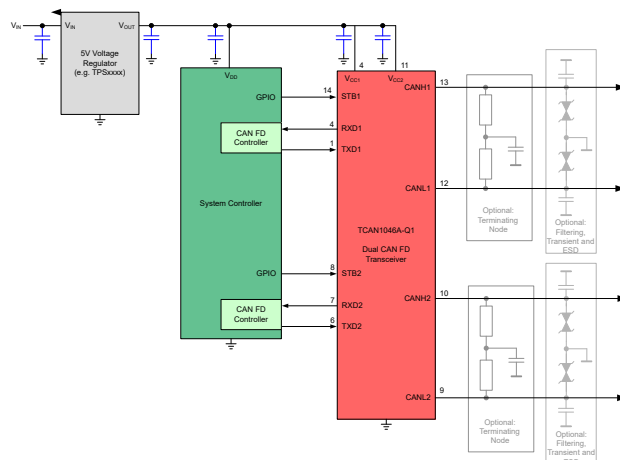

简化版原理图



## 4 Pin Configuration and Functions



图 4-1. D Package, 14 Pin SOIC, Top View



图 4-2. DMT Package, 14 Pin VSON, Top View

表 4-1. Pin Functions

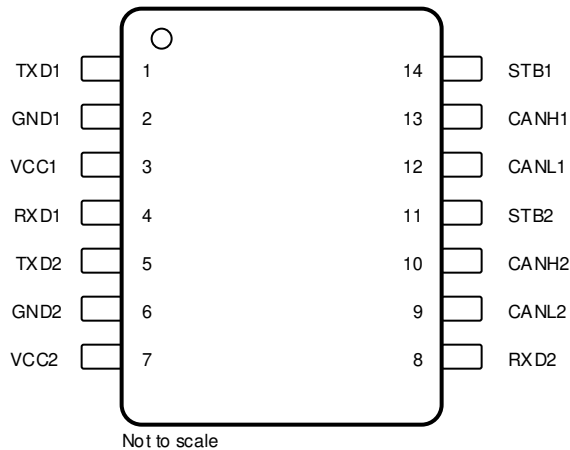
Pins		Type	Description
Name	No.		
TXD1	1	Digital Input	CAN transmit data input 1, integrated pull-up
GND1	2	GND1	Ground connection, transceiver 1
V <sub>CC1</sub>	3	Supply	5-V supply voltage, transceiver 1
RXD1	4	Digital Output	CAN receive data output 1, tri-state when $V_{CC} < UV_{VCC}$
TXD2	5	Digital Input	CAN transmit data input 2, integrated pull-up
GND2	6	GND2	Ground connection, transceiver 2
V <sub>CC2</sub>	7	Supply	5-V supply voltage, transceiver 2
RXD2	8	Digital Output	CAN receive data output 2, tri-state when $V_{CC} < UV_{VCC}$
CANL2	9	Bus IO	Low-level CAN bus 2 input/output line
CANH2	10	Bus IO	High-level CAN bus 2 input/output line
STB2	11	Digital Input	Standby input 2 for mode control, integrated pull-up
CANL1	12	Bus IO	Low-level CAN bus 1 input/output line
CANH1	13	Bus IO	High-level CAN bus 1 input/output line
STB1	14	Digital Input	Standby input 1 for mode control, integrated pull-up
Thermal Pad (VSON only)		—	Electrically connected to GND, connect the thermal pad to the printed circuit board (PCB) ground plane for thermal relief

## 5 Device and Documentation Support

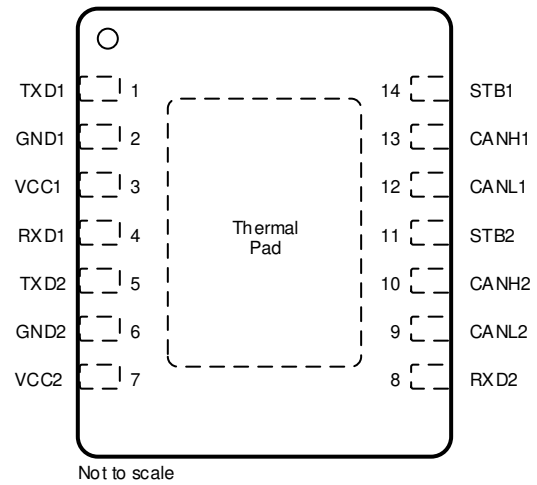
### 5.1 Device Support

This device conforms to the following CAN standards. The core of what is needed is covered within this system specification; however, reference should be made to these standards and any discrepancies pointed out and discussed. This document should provide all the basics of what is needed. However, for a full understanding of CAN including the protocol these additional sources are helpful as the scope of CAN protocol in detail is outside the scope of this physical layer (transceiver) specification.

#### 5.1.1 Device Nomenclature

CAN Transceiver Physical Layer Standards:

- ISO 11898-2:2016 High speed medium access unit (original High Speed CAN transceiver standard)
- ISO 11898-5 High speed medium access unit with low power mode (super sets -2 standard electrically in several specs and adds the original wake up capability via the bus in low power mode).
- ISO 11898-6 High speed medium access unit with selective wake.
- ISO 8802-3: CSMA/CD - referenced for collision detection from ISO11898-2
- CAN FD 1.0 Spec and Papers
- Bosch “Configuration of CAN Bit Timing”, Paper from 6th International CAN Conference (ICC), 1999. This is repeated a lot in the DCAN IP CAN Controller spec copied into this system spec.
- GMW3122: GM requirements for HS CAN
- SAE J2284-2: High Speed CAN (HSC) for Vehicle Applications at 250 kbps
- SAE J2284-3: High Speed CAN (HSC) for Vehicle Applications at 500 kbps

EMC requirements:

- HW Requirements for CAN, LIN, FR V1.3: German OEM requirements for HS CAN

Conformance Test requirements:

- HS\_TRX\_Test\_Spec\_V\_1\_0: GIFT / ICT CAN test requirements for High Speed Physical Layer

### 5.2 接收文档更新通知

要接收文档更新通知，请导航至 [ti.com](https://www.ti.com) 上的器件产品文件夹。点击 [订阅更新](#) 进行注册，即可每周接收产品信息更改摘要。有关更改的详细信息，请查看任何已修订文档中包含的修订历史记录。

### 5.3 支持资源

[TI E2E™ 支持论坛](#) 是工程师的重要参考资料，可直接从专家获得快速、经过验证的解答和设计帮助。搜索现有解答或提出自己的问题可获得所需的快速设计帮助。

链接的内容由各个贡献者“按原样”提供。这些内容并不构成 TI 技术规范，并且不一定反映 TI 的观点；请参阅 TI 的《[使用条款](#)》。

### 5.4 Trademarks

TI E2E™ is a trademark of Texas Instruments.

所有商标均为其各自所有者的财产。

### 5.5 Electrostatic Discharge Caution



This integrated circuit can be damaged by ESD. Texas Instruments recommends that all integrated circuits be handled with appropriate precautions. Failure to observe proper handling and installation procedures can cause damage.

ESD damage can range from subtle performance degradation to complete device failure. Precision integrated circuits may be more susceptible to damage because very small parametric changes could cause the device not to meet its published specifications.

## 5.6 术语表

[TI 术语表](#) 本术语表列出并解释了术语、首字母缩略词和定义。

### **Mechanical, Packaging, and Orderable Information**

The following pages include mechanical, packaging, and orderable information. This information is the most current data available for the designated devices. This data is subject to change without notice and revision of this document. For browser-based versions of this data sheet, refer to the left-hand navigation.

### 6.1 Tape and Reel Information

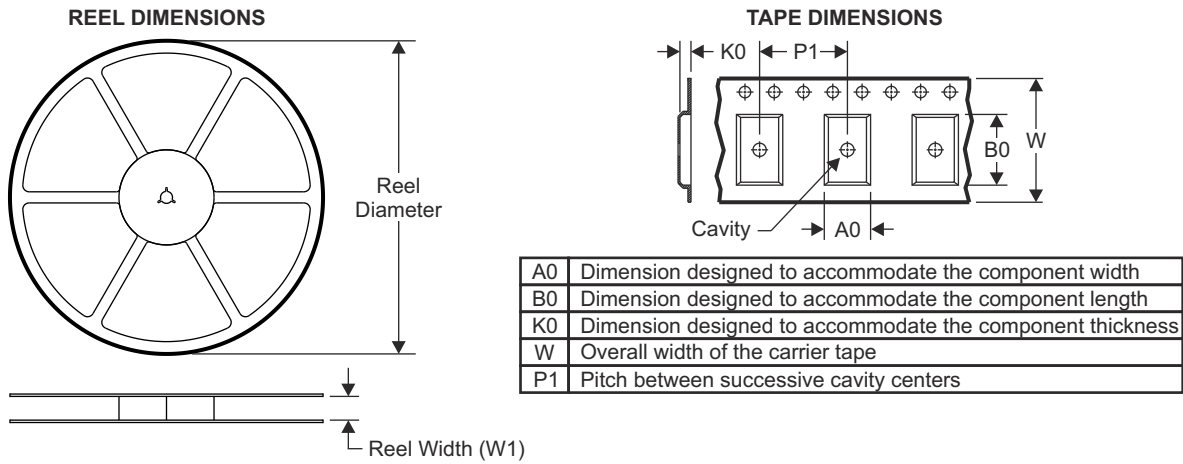

#### QUADRANT ASSIGNMENTS FOR PIN 1 ORIENTATION IN TAPE

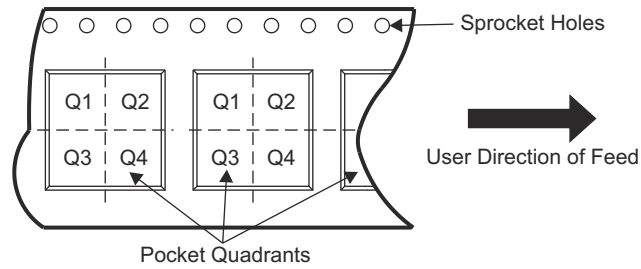

Device	Package Type	Package Drawing	Pins	SPQ	Reel Diameter (mm)	Reel Width W1 (mm)	A0 (mm)	B0 (mm)	K0 (mm)	P1 (mm)	W (mm)	Pin1 Quadrant
TCAN1046ADMTRQ1	VSON	DMT	14	3000	330.0	12.4	3.2	4.7	1.15	8.0	12.0	Q1
TCAN1046ADRQ1	SOIC	D	14	2500	330.0	16.4	6.5	9.0	2.1	8.0	16.0	Q1

**ADVANCE INFORMATION**

**TAPE AND REEL BOX DIMENSIONS**

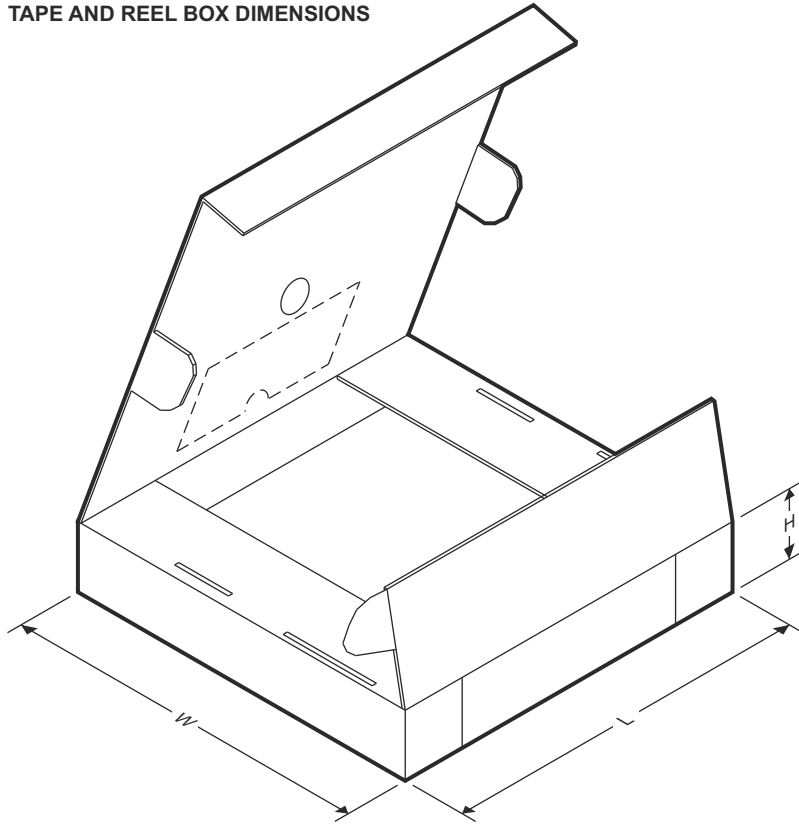

**ADVANCE INFORMATION**

Device	Package Type	Package Drawing	Pins	SPQ	Length (mm)	Width (mm)	Height (mm)
TCAN1046ADMTRQ1	VSON	DMT	14	3000	370.0	355.0	55.0
TCAN1046ADRQ1	SOIC	D	14	2500	853.0	449.0	35.0



## PACKAGE OUTLINE

**D0014A**

**SOIC - 1.75 mm max height**

SMALL OUTLINE INTEGRATED CIRCUIT

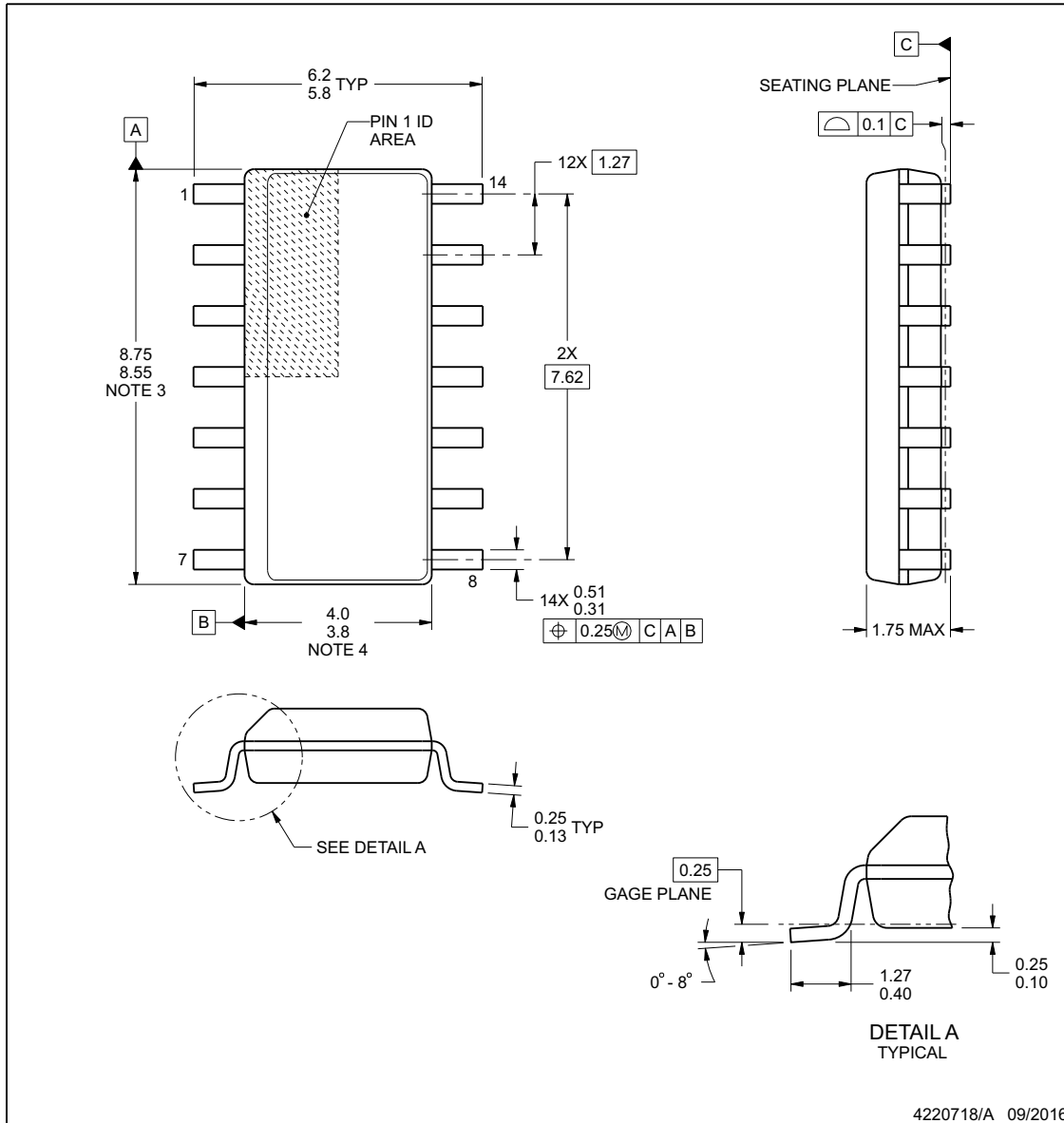

**NOTES:**

1. All linear dimensions are in millimeters. Dimensions in parenthesis are for reference only. Dimensioning and tolerancing per ASME Y14.5M.
2. This drawing is subject to change without notice.
3. This dimension does not include mold flash, protrusions, or gate burrs. Mold flash, protrusions, or gate burrs shall not exceed 0.15 mm, per side.
4. This dimension does not include interlead flash. Interlead flash shall not exceed 0.43 mm, per side.
5. Reference JEDEC registration MS-012, variation AB.

www.ti.com

**ADVANCE INFORMATION**

## EXAMPLE BOARD LAYOUT

**D0014A**

**SOIC - 1.75 mm max height**

SMALL OUTLINE INTEGRATED CIRCUIT

ADVANCE INFORMATION

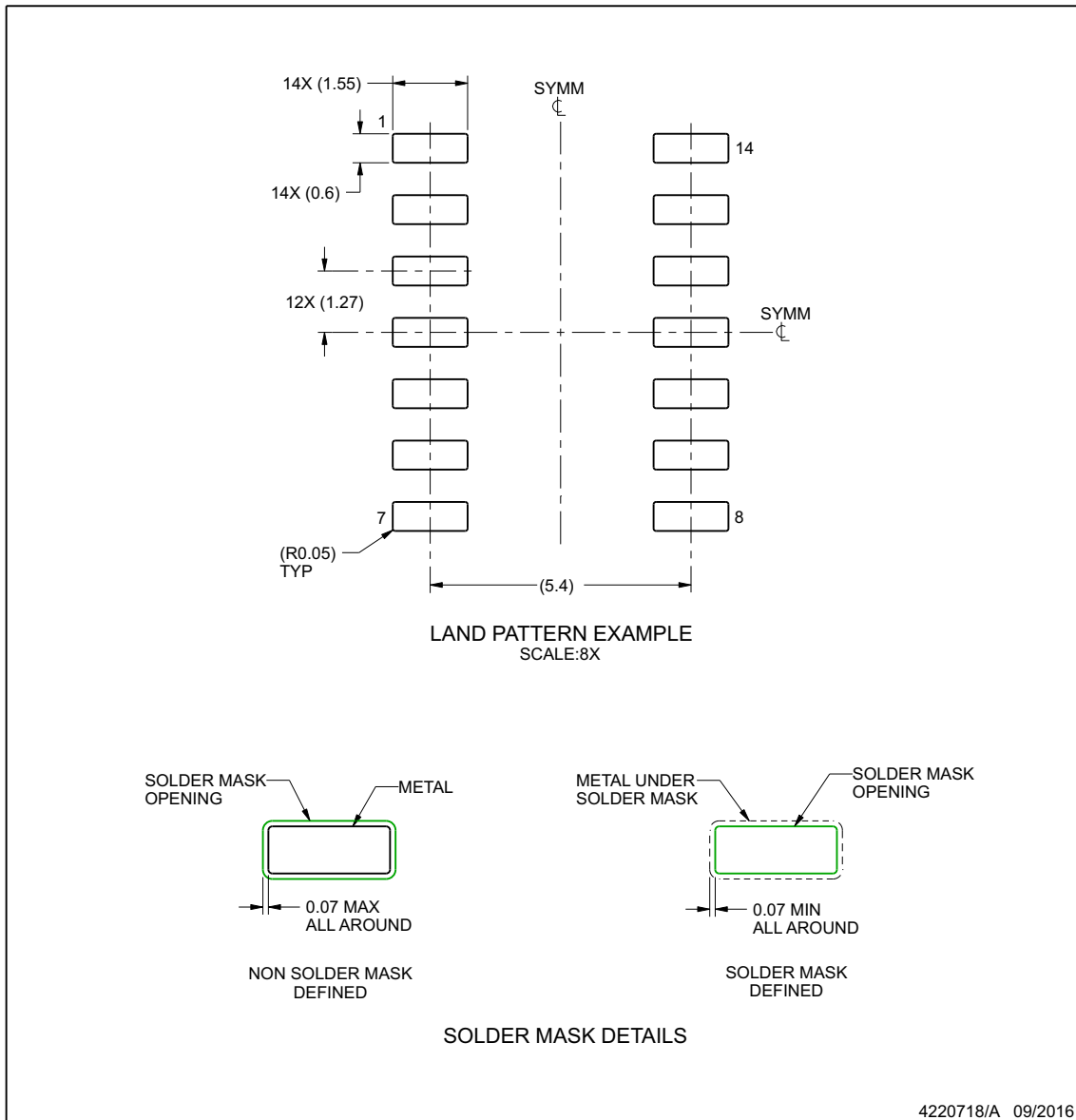

4220718/A 09/2016

NOTES: (continued)

- 6. Publication IPC-7351 may have alternate designs.
- 7. Solder mask tolerances between and around signal pads can vary based on board fabrication site.

www.ti.com



## EXAMPLE STENCIL DESIGN

**D0014A**

**SOIC - 1.75 mm max height**

SMALL OUTLINE INTEGRATED CIRCUIT

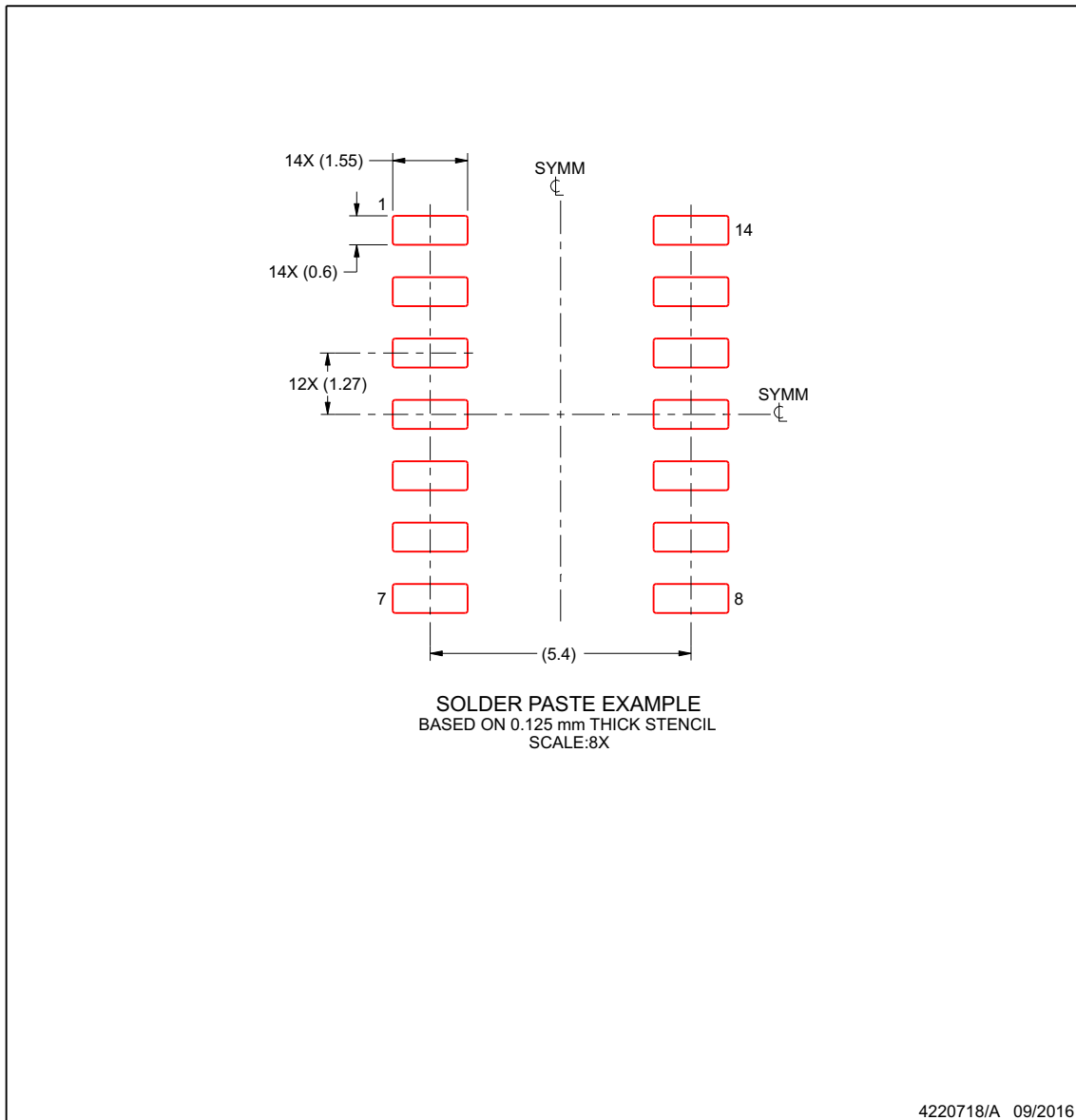

NOTES: (continued)

- 8. Laser cutting apertures with trapezoidal walls and rounded corners may offer better paste release. IPC-7525 may have alternate design recommendations.
- 9. Board assembly site may have different recommendations for stencil design.

www.ti.com

ADVANCE INFORMATION



**DMT0014B**

**PACKAGE OUTLINE**  
**VSON - 1 mm max height**

PLASTIC SMALL OUTLINE - NO LEAD

ADVANCE INFORMATION

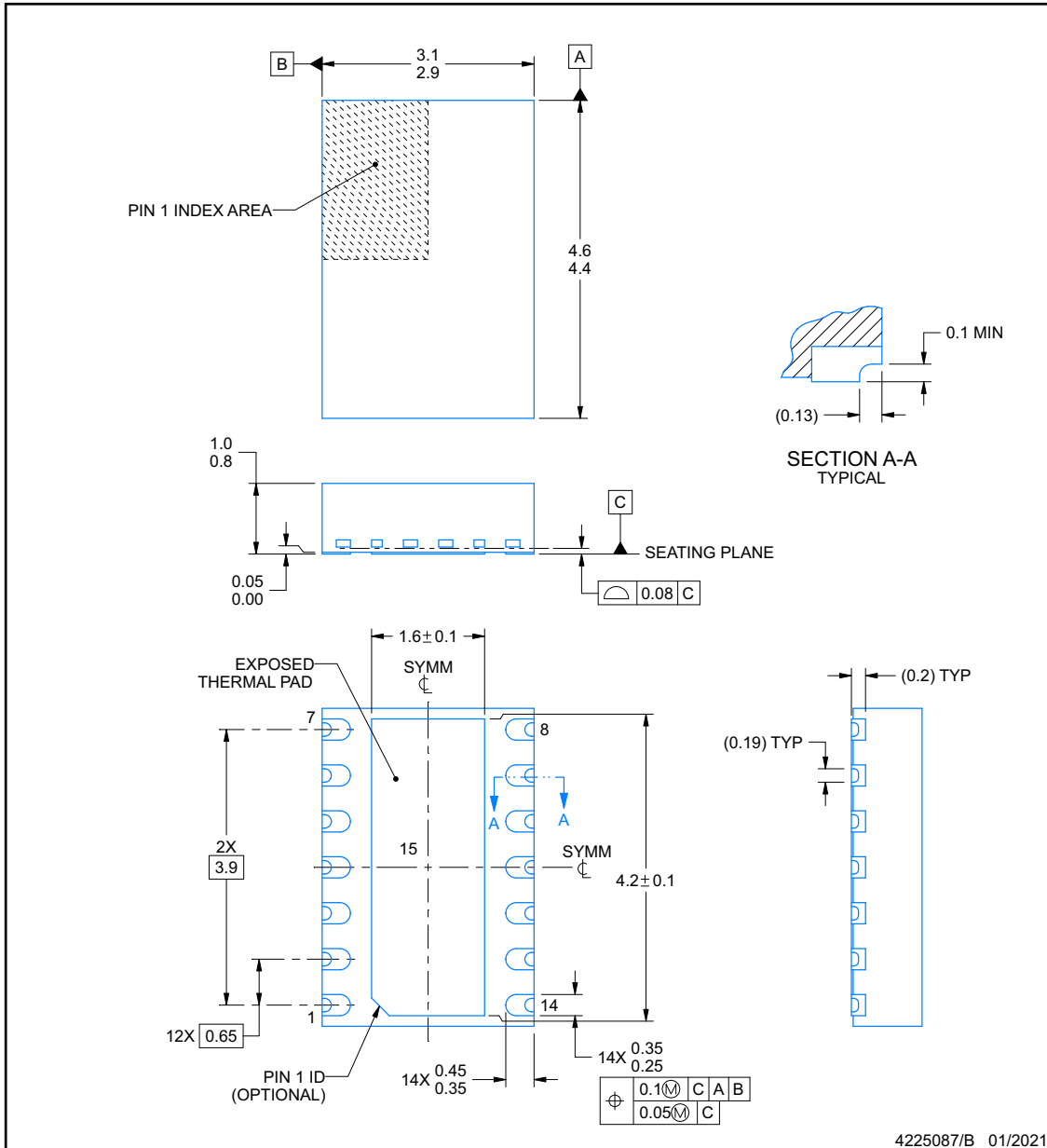

NOTES:

1. All linear dimensions are in millimeters. Any dimensions in parenthesis are for reference only. Dimensioning and tolerancing per ASME Y14.5M.
2. This drawing is subject to change without notice.
3. The package thermal pad must be soldered to the printed circuit board for thermal and mechanical performance.

## EXAMPLE BOARD LAYOUT

**DMT0014B**

**VSON - 1 mm max height**

PLASTIC SMALL OUTLINE - NO LEAD

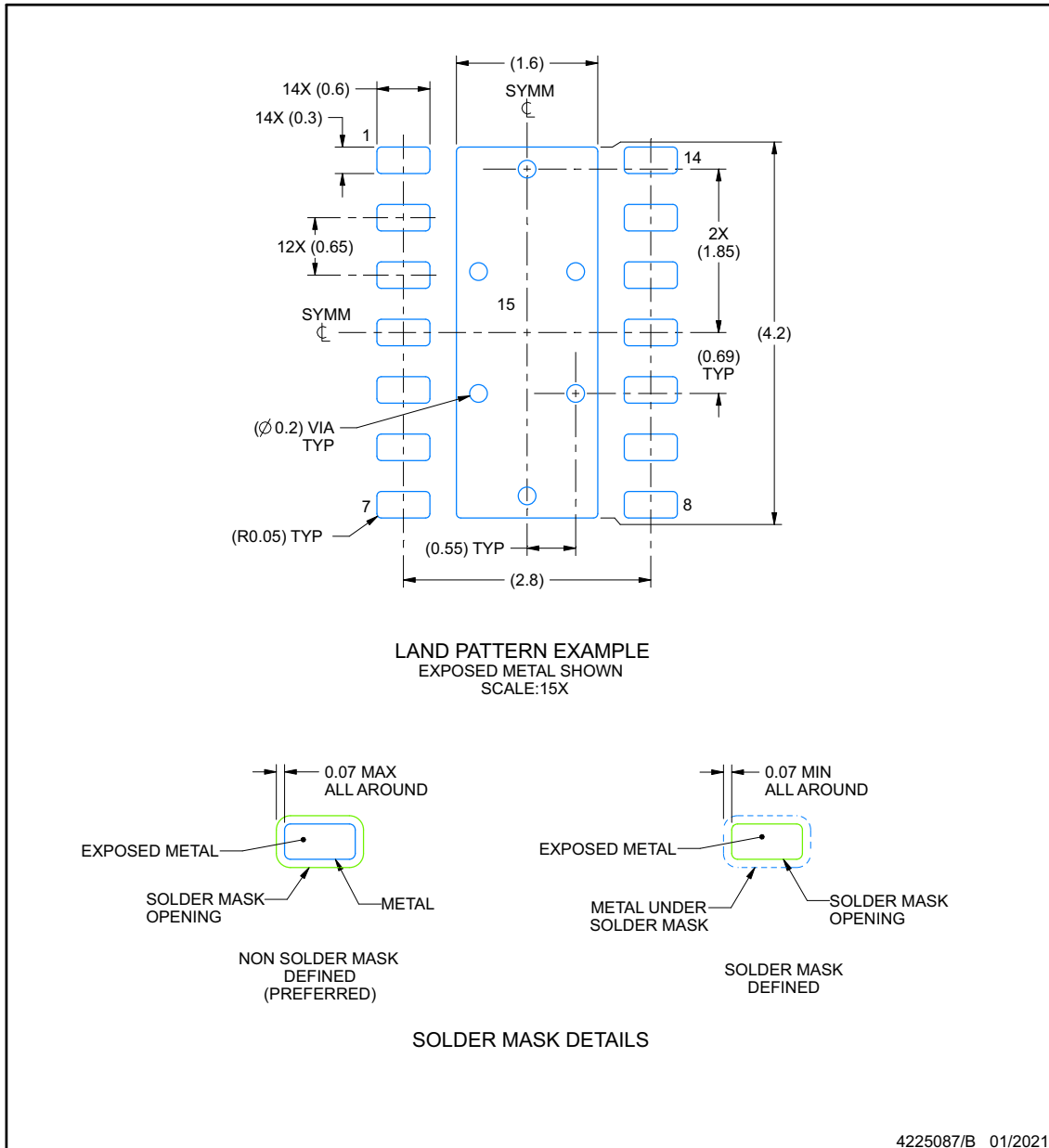

NOTES: (continued)

4. This package is designed to be soldered to a thermal pad on the board. For more information, see Texas Instruments literature number SLUA271 ([www.ti.com/lit/sluea271](http://www.ti.com/lit/sluea271)).
5. Vias are optional depending on application, refer to device data sheet. If any vias are implemented, refer to their locations shown on this view. It is recommended that vias under paste be filled, plugged or tented.

## EXAMPLE STENCIL DESIGN

**DMT0014B**

**VSON - 1 mm max height**

PLASTIC SMALL OUTLINE - NO LEAD

**ADVANCE INFORMATION**

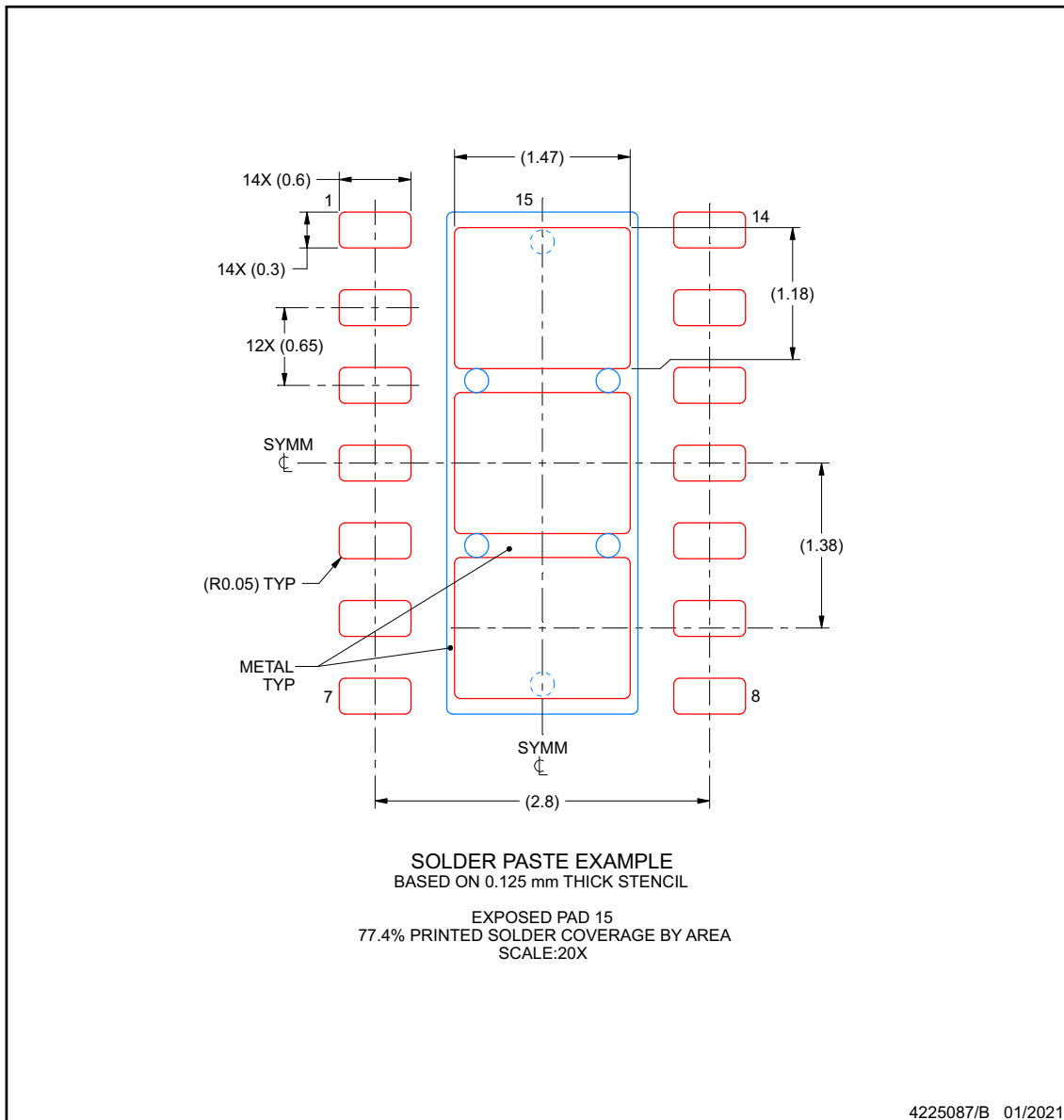

NOTES: (continued)

6. Laser cutting apertures with trapezoidal walls and rounded corners may offer better paste release. IPC-7525 may have alternate design recommendations.

## 重要声明和免责声明

TI 提供技术和可靠性数据 (包括数据表)、设计资源 (包括参考设计)、应用或其他设计建议、网络工具、安全信息和其他资源, 不保证没有瑕疵且不做任何明示或暗示的担保, 包括但不限于对适销性、某特定用途方面的适用性或不侵犯任何第三方知识产权的暗示担保。

这些资源可供使用 TI 产品进行设计的熟练开发人员使用。您将自行承担以下全部责任: (1) 针对您的应用选择合适的 TI 产品, (2) 设计、验证并测试您的应用, (3) 确保您的应用满足相应标准以及任何其他安全、安保或其他要求。这些资源如有变更, 恕不另行通知。TI 授权您仅可将这些资源用于研发本资源所述的 TI 产品的应用。严禁对这些资源进行其他复制或展示。您无权使用任何其他 TI 知识产权或任何第三方知识产权。您应全额赔偿因在这些资源的使用中对 TI 及其代表造成的任何索赔、损害、成本、损失和债务, TI 对此概不负责。

TI 提供的产品受 TI 的销售条款 (<https://www.ti.com/legal/termsofsale.html>) 或 [ti.com](https://www.ti.com) 上其他适用条款/TI 产品随附的其他适用条款的约束。TI 提供这些资源并不会扩展或以其他方式更改 TI 针对 TI 产品发布的适用的担保或担保免责声明。

邮寄地址: Texas Instruments, Post Office Box 655303, Dallas, Texas 75265  
Copyright © 2021, 德州仪器 (TI) 公司

**PACKAGING INFORMATION**

Orderable Device	Status (1)	Package Type	Package Drawing	Pins	Package Qty	Eco Plan (2)	Lead finish/ Ball material (6)	MSL Peak Temp (3)	Op Temp (°C)	Device Marking (4/5)	Samples
TCAN1046ADMTRQ1	ACTIVE	VSON	DMT	14	3000	RoHS & Green	NIPDAU	Level-2-260C-1 YEAR	-40 to 150	1046A	<a href="#">Samples</a>
TCAN1046ADRQ1	ACTIVE	SOIC	D	14	2500	RoHS & Green	NIPDAU	Level-1-260C-UNLIM	-40 to 150	1046A	<a href="#">Samples</a>

(1) The marketing status values are defined as follows:

**ACTIVE:** Product device recommended for new designs.

**LIFEBUY:** TI has announced that the device will be discontinued, and a lifetime-buy period is in effect.

**NRND:** Not recommended for new designs. Device is in production to support existing customers, but TI does not recommend using this part in a new design.

**PREVIEW:** Device has been announced but is not in production. Samples may or may not be available.

**OBSELETE:** TI has discontinued the production of the device.

(2) **RoHS:** TI defines "RoHS" to mean semiconductor products that are compliant with the current EU RoHS requirements for all 10 RoHS substances, including the requirement that RoHS substance do not exceed 0.1% by weight in homogeneous materials. Where designed to be soldered at high temperatures, "RoHS" products are suitable for use in specified lead-free processes. TI may reference these types of products as "Pb-Free".

**RoHS Exempt:** TI defines "RoHS Exempt" to mean products that contain lead but are compliant with EU RoHS pursuant to a specific EU RoHS exemption.

**Green:** TI defines "Green" to mean the content of Chlorine (Cl) and Bromine (Br) based flame retardants meet JS709B low halogen requirements of <=1000ppm threshold. Antimony trioxide based flame retardants must also meet the <=1000ppm threshold requirement.

(3) MSL, Peak Temp. - The Moisture Sensitivity Level rating according to the JEDEC industry standard classifications, and peak solder temperature.

(4) There may be additional marking, which relates to the logo, the lot trace code information, or the environmental category on the device.

(5) Multiple Device Markings will be inside parentheses. Only one Device Marking contained in parentheses and separated by a "~" will appear on a device. If a line is indented then it is a continuation of the previous line and the two combined represent the entire Device Marking for that device.

(6) Lead finish/Ball material - Orderable Devices may have multiple material finish options. Finish options are separated by a vertical ruled line. Lead finish/Ball material values may wrap to two lines if the finish value exceeds the maximum column width.

**Important Information and Disclaimer:**The information provided on this page represents TI's knowledge and belief as of the date that it is provided. TI bases its knowledge and belief on information provided by third parties, and makes no representation or warranty as to the accuracy of such information. Efforts are underway to better integrate information from third parties. TI has taken and continues to take reasonable steps to provide representative and accurate information but may not have conducted destructive testing or chemical analysis on incoming materials and chemicals. TI and TI suppliers consider certain information to be proprietary, and thus CAS numbers and other limited information may not be available for release.

In no event shall TI's liability arising out of such information exceed the total purchase price of the TI part(s) at issue in this document sold by TI to Customer on an annual basis.





# D0014A

# PACKAGE OUTLINE

## SOIC - 1.75 mm max height

SMALL OUTLINE INTEGRATED CIRCUIT



4220718/A 09/2016

### NOTES:

1. All linear dimensions are in millimeters. Dimensions in parenthesis are for reference only. Dimensioning and tolerancing per ASME Y14.5M.
2. This drawing is subject to change without notice.
3. This dimension does not include mold flash, protrusions, or gate burrs. Mold flash, protrusions, or gate burrs shall not exceed 0.15 mm, per side.
4. This dimension does not include interlead flash. Interlead flash shall not exceed 0.43 mm, per side.
5. Reference JEDEC registration MS-012, variation AB.



# EXAMPLE BOARD LAYOUT

D0014A

SOIC - 1.75 mm max height

SMALL OUTLINE INTEGRATED CIRCUIT



LAND PATTERN EXAMPLE  
SCALE:8X



SOLDER MASK DETAILS

4220718/A 09/2016

NOTES: (continued)

- 6. Publication IPC-7351 may have alternate designs.
- 7. Solder mask tolerances between and around signal pads can vary based on board fabrication site.

# EXAMPLE STENCIL DESIGN

D0014A

SOIC - 1.75 mm max height

SMALL OUTLINE INTEGRATED CIRCUIT



SOLDER PASTE EXAMPLE  
BASED ON 0.125 mm THICK STENCIL  
SCALE:8X

4220718/A 09/2016

NOTES: (continued)

8. Laser cutting apertures with trapezoidal walls and rounded corners may offer better paste release. IPC-7525 may have alternate design recommendations.
9. Board assembly site may have different recommendations for stencil design.

## GENERIC PACKAGE VIEW

**DMT 14**

**VSON - 0.9 mm max height**

3 x 4.5, 0.65 mm pitch

PLASTIC SMALL OUTLINE - NO LEAD

This image is a representation of the package family, actual package may vary.  
Refer to the product data sheet for package details.

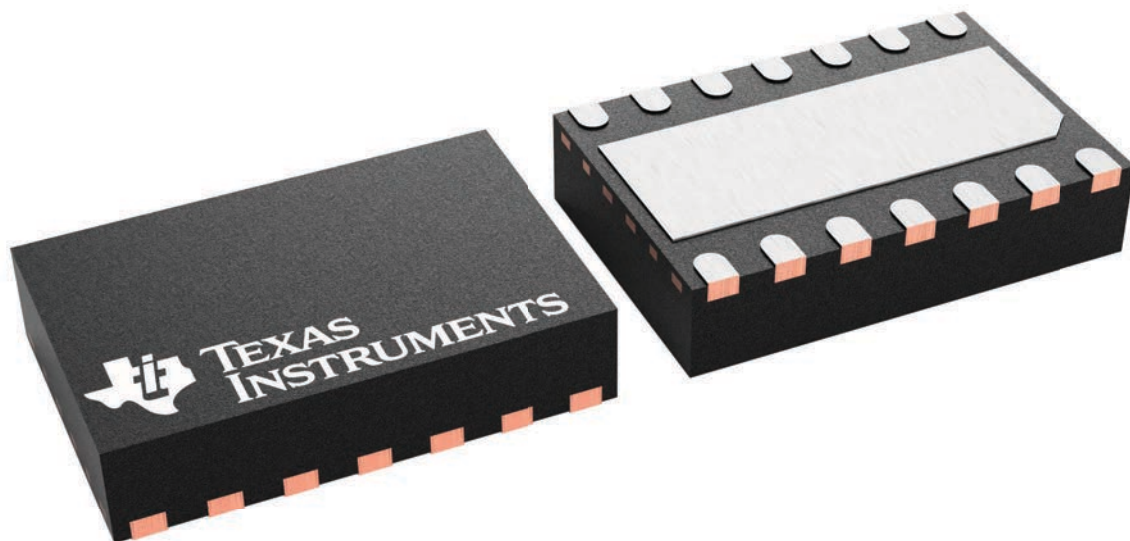

4225088/A

# DMT0014B



## PACKAGE OUTLINE

VSON - 1 mm max height

PLASTIC SMALL OUTLINE - NO LEAD

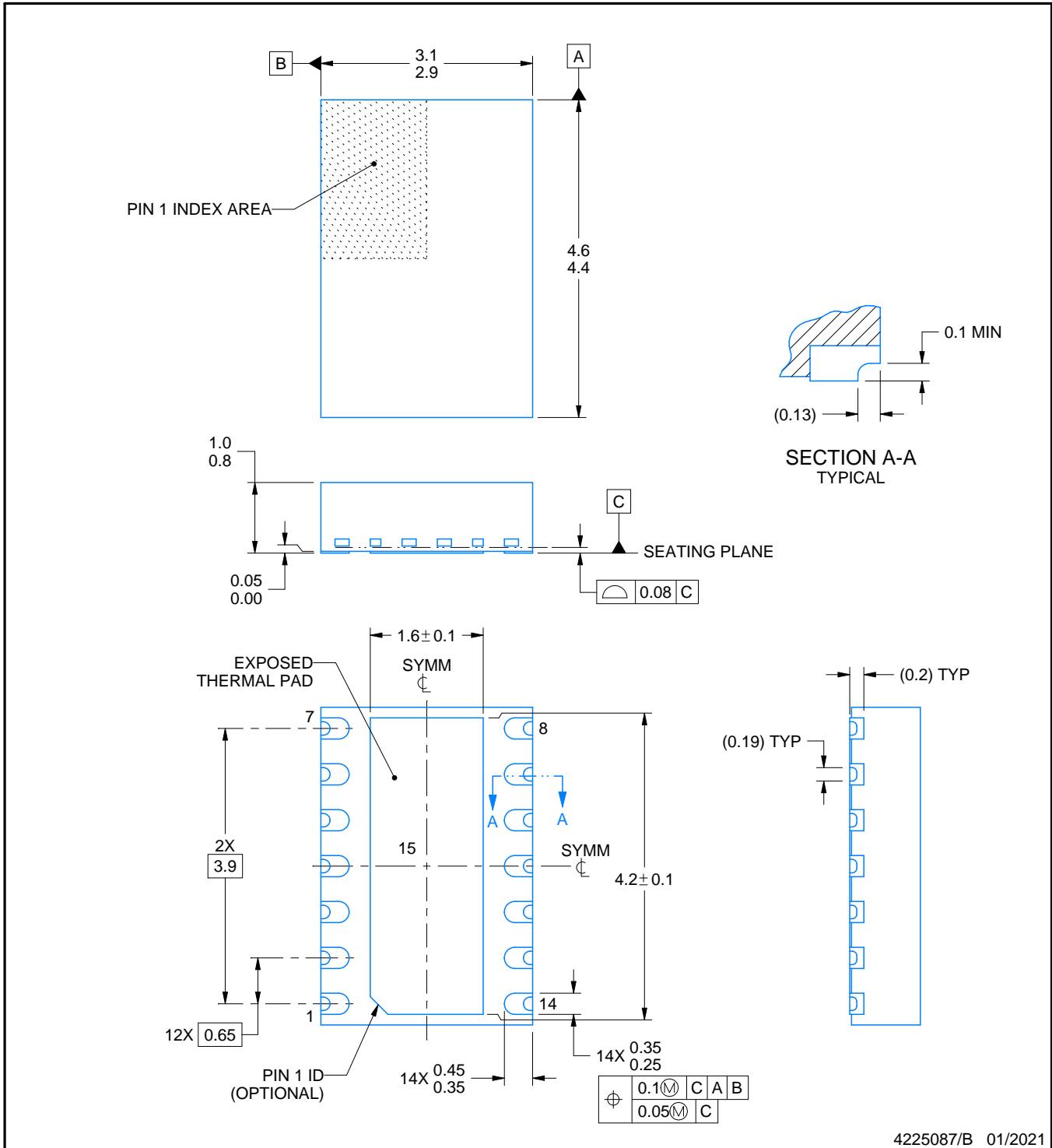

4225087/B 01/2021

**NOTES:**

1. All linear dimensions are in millimeters. Any dimensions in parenthesis are for reference only. Dimensioning and tolerancing per ASME Y14.5M.
2. This drawing is subject to change without notice.
3. The package thermal pad must be soldered to the printed circuit board for thermal and mechanical performance.



# EXAMPLE STENCIL DESIGN

DMT0014B

VSON - 1 mm max height

PLASTIC SMALL OUTLINE - NO LEAD

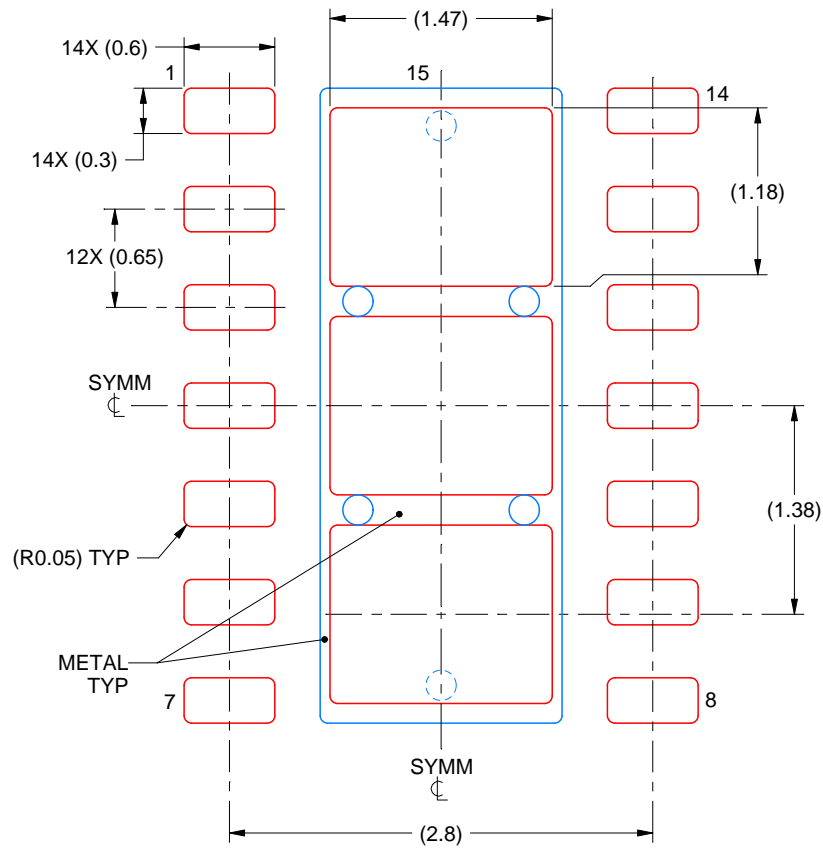

SOLDER PASTE EXAMPLE  
BASED ON 0.125 mm THICK STENCIL  
EXPOSED PAD 15  
77.4% PRINTED SOLDER COVERAGE BY AREA  
SCALE:20X

4225087/B 01/2021

NOTES: (continued)

6. Laser cutting apertures with trapezoidal walls and rounded corners may offer better paste release. IPC-7525 may have alternate design recommendations.

## 重要声明和免责声明

TI“按原样”提供技术和可靠性数据（包括数据表）、设计资源（包括参考设计）、应用或其他设计建议、网络工具、安全信息和其他资源，不保证没有瑕疵且不做任何明示或暗示的担保，包括但不限于对适销性、某特定用途方面的适用性或不侵犯任何第三方知识产权的暗示担保。

这些资源可供使用 TI 产品进行设计的熟练开发人员使用。您将自行承担以下全部责任：(1) 针对您的应用选择合适的 TI 产品，(2) 设计、验证并测试您的应用，(3) 确保您的应用满足相应标准以及任何其他功能安全、信息安全、监管或其他要求。

这些资源如有变更，恕不另行通知。TI 授权您仅可将这些资源用于研发本资源所述的 TI 产品的应用。严禁对这些资源进行其他复制或展示。您无权使用任何其他 TI 知识产权或任何第三方知识产权。您应全额赔偿因在这些资源的使用中对 TI 及其代表造成的任何索赔、损害、成本、损失和债务，TI 对此概不负责。

TI 提供的产品受 [TI 的销售条款](#) 或 [ti.com](#) 上其他适用条款/TI 产品随附的其他适用条款的约束。TI 提供这些资源并不会扩展或以其他方式更改 TI 针对 TI 产品发布的适用的担保或担保免责声明。

TI 反对并拒绝您可能提出的任何其他或不同的条款。

邮寄地址：Texas Instruments, Post Office Box 655303, Dallas, Texas 75265  
Copyright © 2024，德州仪器 (TI) 公司