

TLC69629-Q1 汽车 60mA、48 通道 LED 驱动器，配备集成振荡器、高级诊断功能和级联串行接口

1 特性

- 符合面向汽车应用的 AEC-Q100 标准
 - 1 级：-40°C 至 125°C 环境工作温度范围
 - 器件 HBM 分类等级 H1C
 - 器件 CDM 分类等级 C4B
- 以符合功能安全标准为目标
 - 专为功能安全应用开发
 - 有助于使 ISO 26262 系统设计满足 ASIL-B 要求的文档
- 48 个集成的电流吸收器
 - 可编程的 16 位 PWM/混合调光
 - 可编程的 7 位模拟点校正 (DC)
 - 最大输出电流/电压：60mA/16V
- 集成的 33MHz 振荡器
 - 500Hz 的 16 位 PWM 输出
 - 采用增强频谱 (ES) PWM 时，刷新率大于 20KHz
- 高速通信
 - 级联串行接口 (CSI)
 - 数据速率高达 17Mbps
- 电源效率优化
 - 自适应余量电压控制 (AHVC)
 - 器件节电模式 (PSM)
- 降低 EMI
 - 接口：可编程缓冲器驱动能力
 - 电流吸收器：相移/展频
- 保护和诊断
 - LED：开路/短路检测/运行状况检查
 - 电流吸收器：相邻引脚短路/运行状况检查
 - 接口：CRC/命令错误/超时错误/通信看门狗
 - 器件：欠压/ISET 超出范围/热关断/存储器 CRC/OTP CRC/OSC 看门狗

2 应用

- 汽车中心信息显示屏
- 汽车仪表组显示屏
- 汽车抬头显示

3 说明

TLC69629-Q1 是一款 LED 驱动器，它具有 48 条恒定电流吸收器通道，可提供高达 16 位的独立像素级 LED PWM 控制。每条通道还实施额外的 7 位点校正 (DC) 以控制峰值电流。每个器件通过级联串行接口 (CSI) 共享数据流，其最多支持 511 个器件的连接。该接口与同一组中的 LED 驱动器软件兼容，可根据 LED 电流和 LED 总数应用于不同的应用场景。

为了优化整体系统电源效率，该器件配备了自适应余量电压控制 (AHVC) 方案，用于优化每条通道和每个器件的余量电压。只需要将菊花链最后一个器件的 OUT47 引脚编程为 FB 引脚，即可优化来自 DC/DC 的 LED 电源电压。

TLC69629-Q1 配备了 LED、电流吸收器、通信和器件的诊断功能。

器件信息

器件型号	封装 ⁽¹⁾	封装尺寸 (标称值)
TLC69629-Q1	VQFN (56) 可湿性侧面	8mm × 8mm
	HTSSOP (56)	14mm × 6.1mm

- (1) 如需了解所有可用封装，请参阅数据表末尾的可订购产品附录。

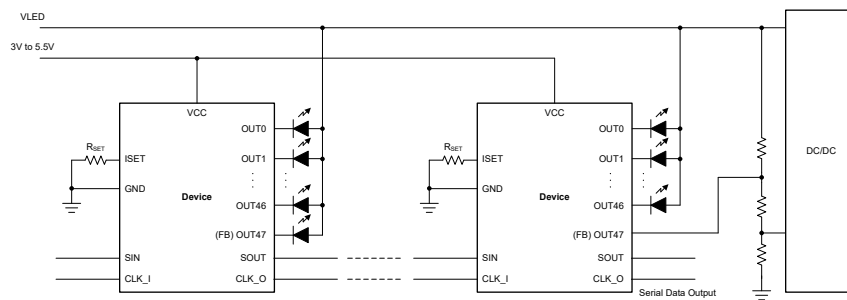

简化版原理图



内容

1 特性.....	1	5.3 商标.....	4
2 应用.....	1	5.4 静电放电警告.....	4
3 说明.....	1	5.5 术语表.....	4
4 器件比较.....	3	6 修订历史记录.....	4
5 器件和文档支持.....	4	7 机械、封装和可订购信息.....	5
5.1 接收文档更新通知.....	4	7.1 卷带包装信息.....	15
5.2 支持资源.....	4		

4 器件比较

器件型号	通道编号	最大值通道电流	功能安全分类	接口	软件兼容
TLC69621-Q1 ⁽¹⁾	8	60mA	功能安全型	SPI	组 1
TLC69624-Q1 ⁽¹⁾	24				
TLC69627-Q1	48				
TLC69631-Q1 ⁽¹⁾	8	100mA	功能安全型	SPI	组 1
TLC69634-Q1 ⁽¹⁾	24				
TLC69637-Q1	48				
TLC69622-Q1 ⁽¹⁾	8	60mA	符合功能安全标准	SPI	组 2
TLC69625-Q1 ⁽¹⁾	24				
TLC69628-Q1	48				
TLC69632-Q1 ⁽¹⁾	8	100mA	符合功能安全标准	SPI	组 2
TLC69635-Q1 ⁽¹⁾	24				
TLC69638-Q1	48				
TLC69623-Q1 ⁽¹⁾	8	60mA	符合功能安全标准	CSI	组 3
TLC69626-Q1 ⁽¹⁾	24				
TLC69629-Q1	48				
TLC69633-Q1 ⁽¹⁾	8	100mA	符合功能安全标准	CSI	组 3
TLC69636-Q1 ⁽¹⁾	24				
TLC69639-Q1	48				

(1) 产品预发布

5 器件和文档支持

TI 提供广泛的开发工具。下面列出了用于评估器件性能、生成代码和开发解决方案的工具和软件。

5.1 接收文档更新通知

要接收文档更新通知，请导航至 [ti.com](https://www.ti.com) 上的器件产品文件夹。点击 [通知](#) 进行注册，即可每周接收产品信息更改摘要。有关更改的详细信息，请查看任何已修订文档中包含的修订历史记录。

5.2 支持资源

[TI E2E™ 中文支持论坛](#) 是工程师的重要参考资料，可直接从专家处获得快速、经过验证的解答和设计帮助。搜索现有解答或提出自己的问题，获得所需的快速设计帮助。

链接的内容由各个贡献者“按原样”提供。这些内容并不构成 TI 技术规范，并且不一定反映 TI 的观点；请参阅 TI 的 [使用条款](#)。

5.3 商标

TI E2E™ is a trademark of Texas Instruments.

所有商标均为其各自所有者的财产。

5.4 静电放电警告



静电放电 (ESD) 会损坏这个集成电路。德州仪器 (TI) 建议通过适当的预防措施处理所有集成电路。如果不遵守正确的处理和安装程序，可能会损坏集成电路。

ESD 的损坏小至导致微小的性能降级，大至整个器件故障。精密的集成电路可能更容易受到损坏，这是因为非常细微的参数更改都可能会导致器件与其发布的规格不相符。

5.5 术语表

TI 术语表

本术语表列出并解释了术语、首字母缩略词和定义。

6 修订历史记录

注：以前版本的页码可能与当前版本的页码不同

日期	修订版本	注释
2025 年 1 月	*	预告信息发布

7 机械、封装和可订购信息

以下页面包含机械、封装和可订购信息。这些信息是指定器件可用的最新数据。数据如有变更，恕不另行通知，且不会对此文档进行修订。有关此数据表的浏览器版本，请查阅左侧的导航栏。

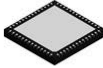
RTQ0056K  **PACKAGE OUTLINE**
VQFN - 1 mm max height
PLASTIC QUAD FLATPACK - NO LEAD

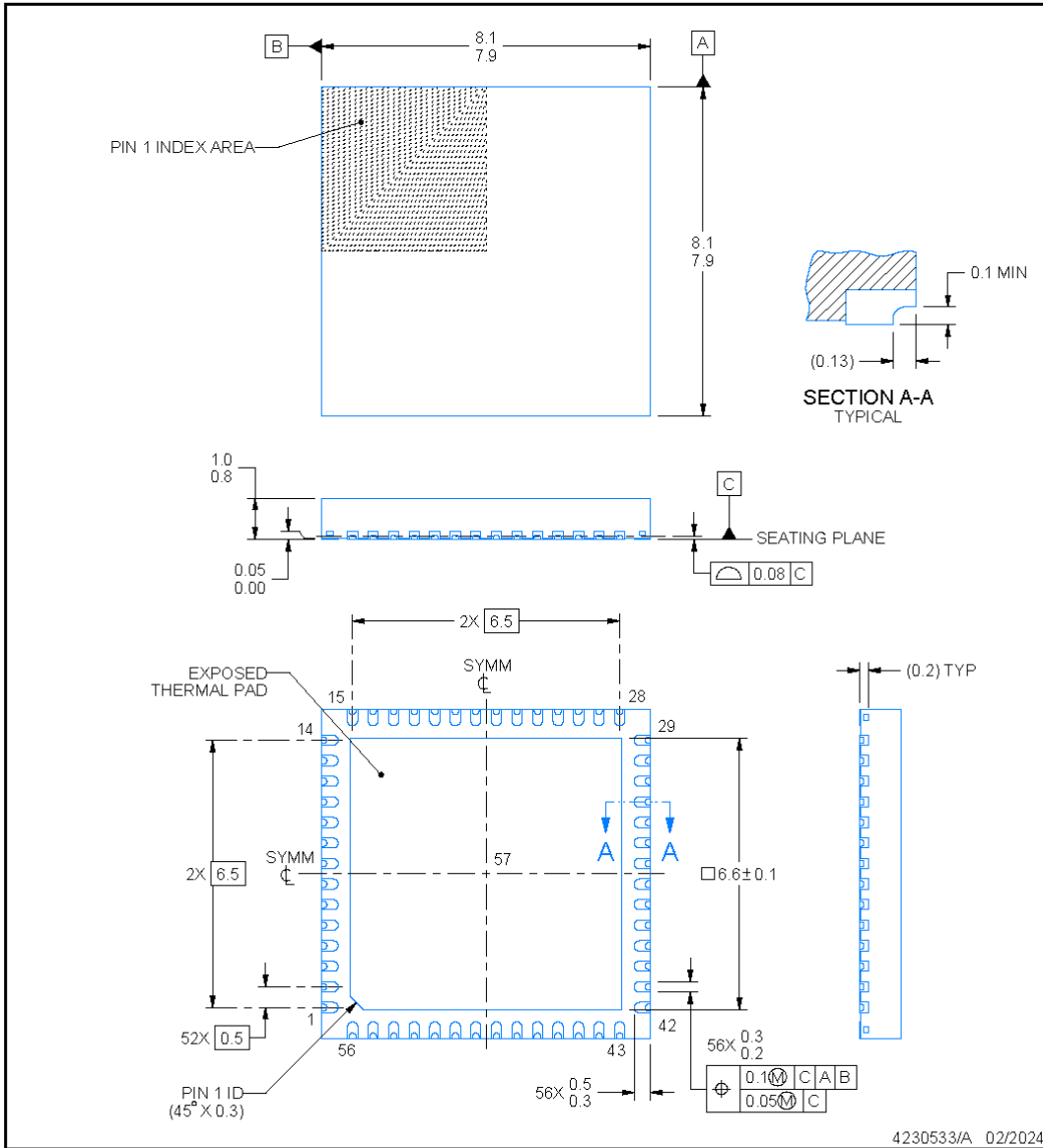

NOTES:

1. All linear dimensions are in millimeters. Any dimensions in parenthesis are for reference only. Dimensioning and tolerancing per ASME Y14.5M.
2. This drawing is subject to change without notice.
3. The package thermal pad must be soldered to the printed circuit board for thermal and mechanical performance.

EXAMPLE BOARD LAYOUT

RTQ0056K

VQFN - 1 mm max height

PLASTIC QUAD FLATPACK - NO LEAD

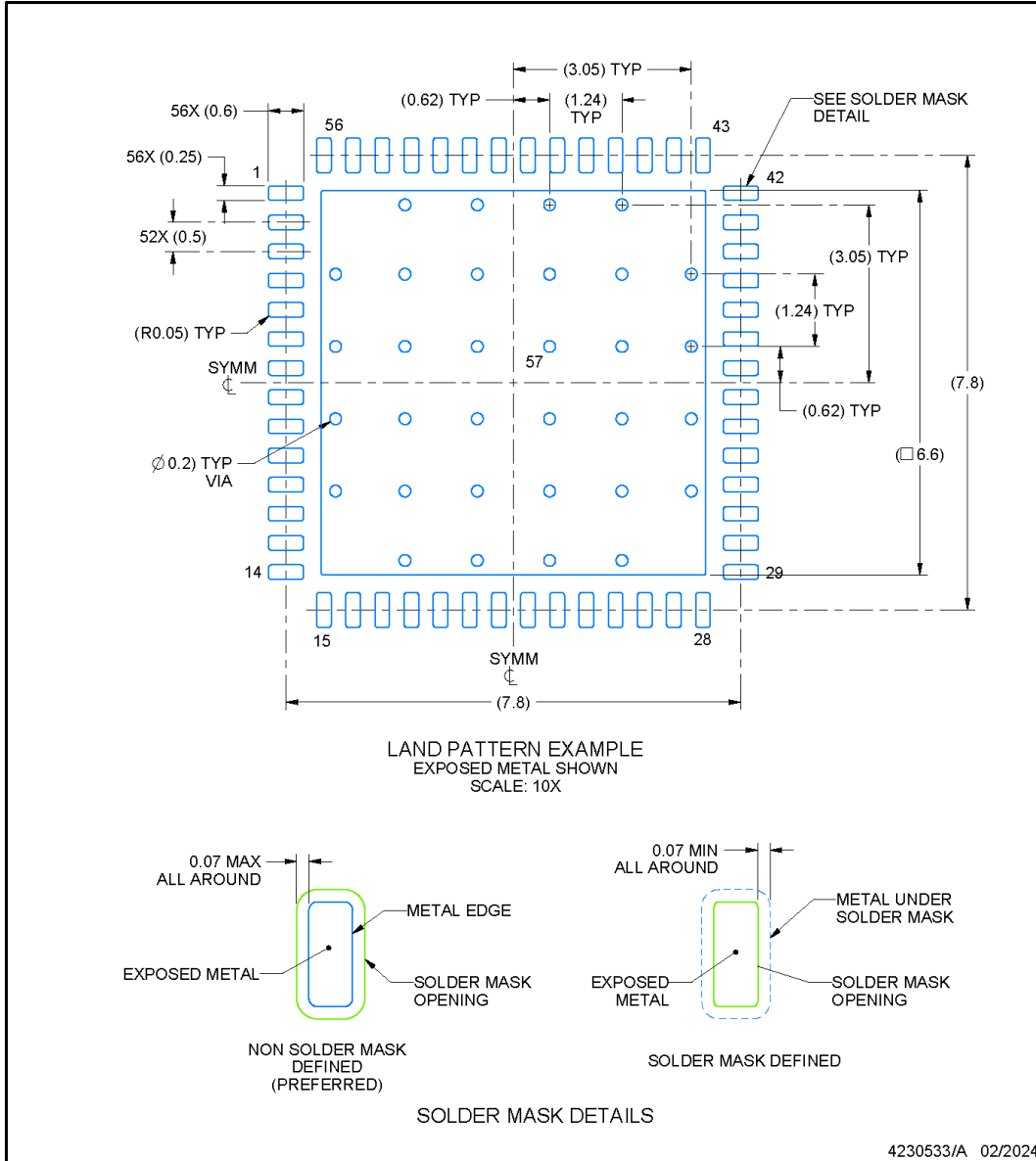

NOTES: (continued)

- This package is designed to be soldered to a thermal pad on the board. For more information, see Texas Instruments literature number SLUA271 (www.ti.com/lit/sl原因271).
- Vias are optional depending on application, refer to device data sheet. If any vias are implemented, refer to their locations shown on this view. It is recommended that vias under paste be filled, plugged or tented.

EXAMPLE STENCIL DESIGN

RTQ0056K

VQFN - 1 mm max height

PLASTIC QUAD FLATPACK - NO LEAD

ADVANCE INFORMATION

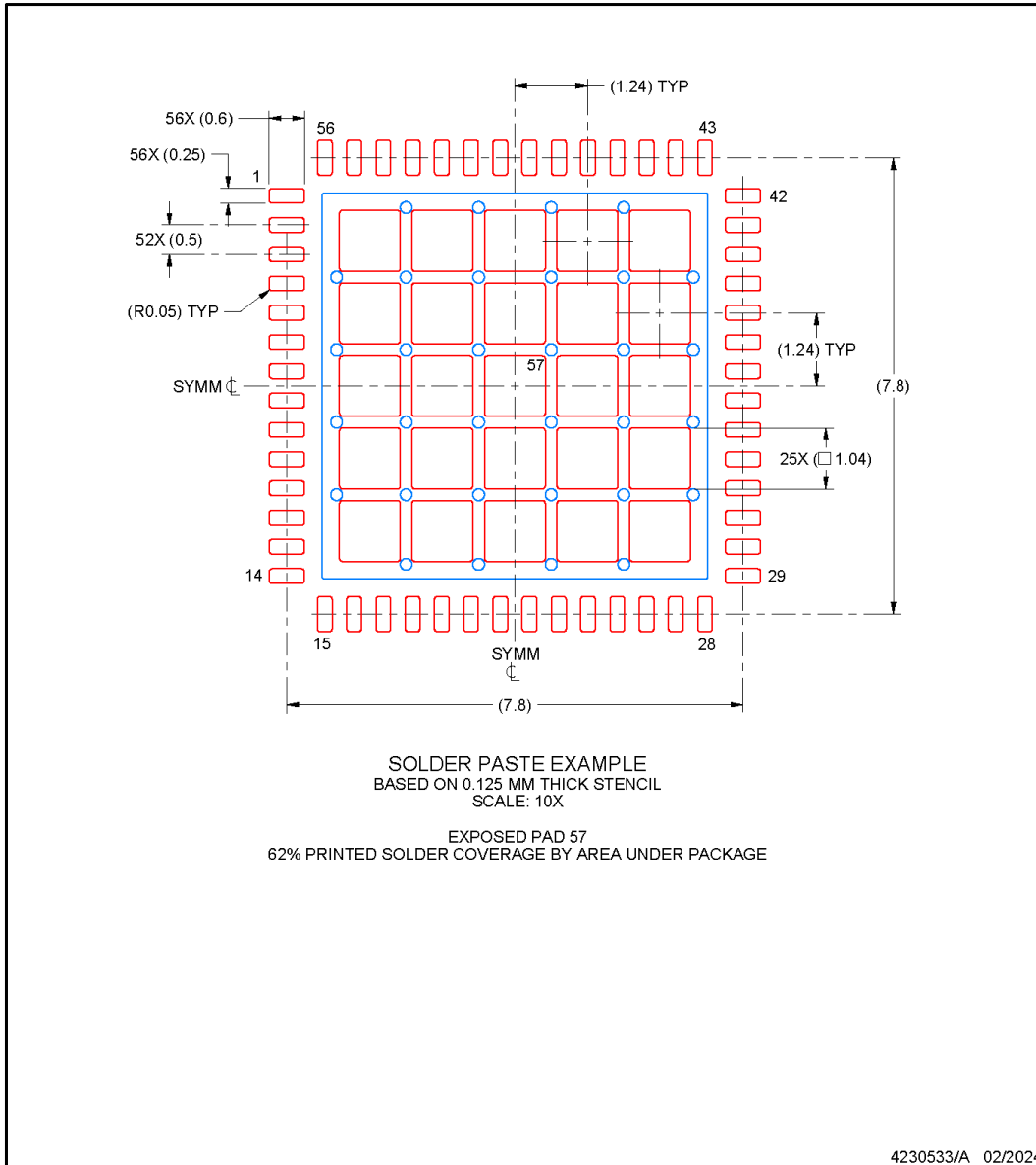

NOTES: (continued)

6. Laser cutting apertures with trapezoidal walls and rounded corners may offer better paste release. IPC-7525 may have alternate design recommendations.

PACKAGE OUTLINE

DCA0056F

HTSSOP - 1.2 mm max height

PowerPAD™ HTSSOP

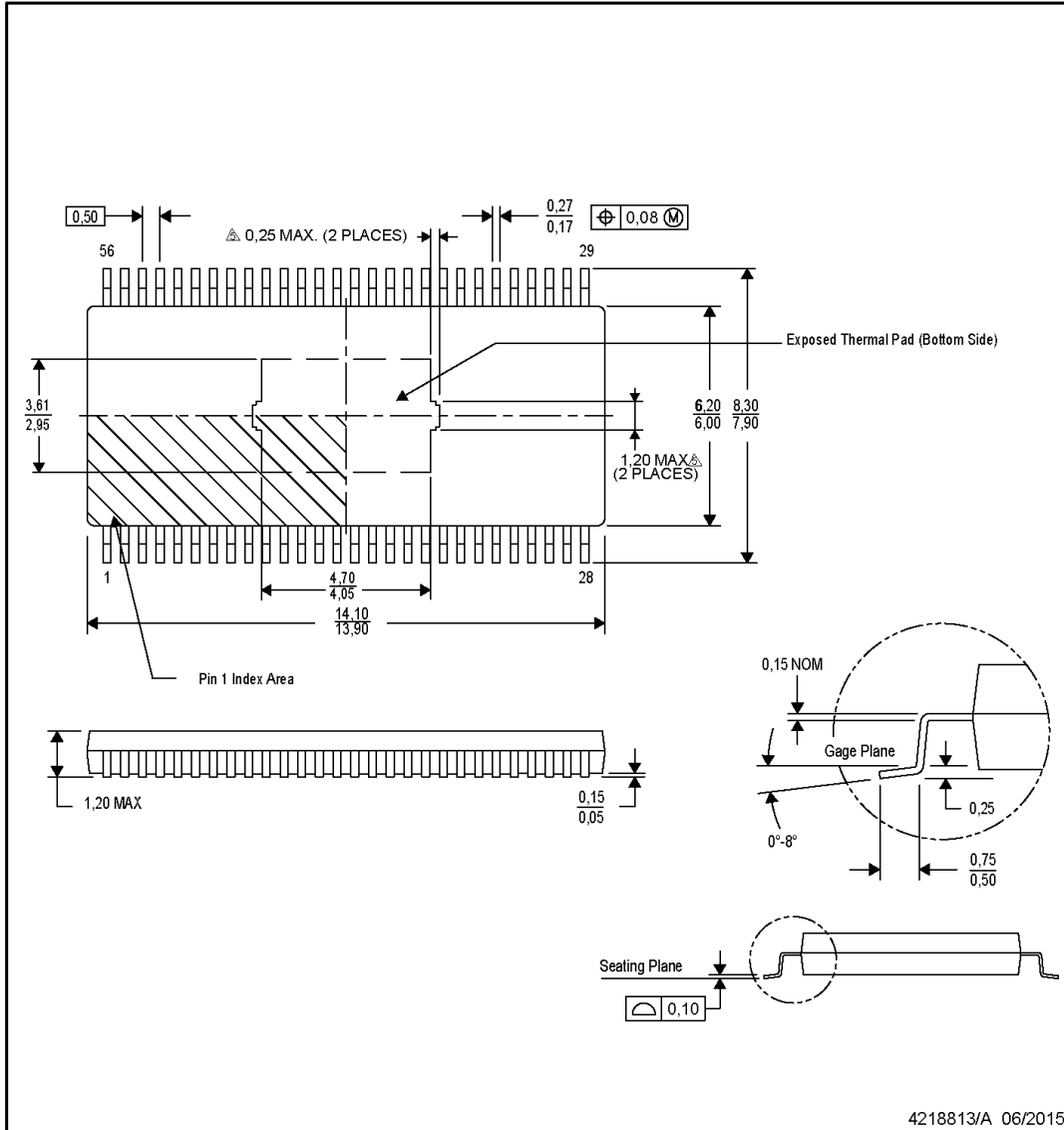

NOTES:

PowerPAD is a trademark of Texas Instruments

1. All linear dimensions are in millimeters. Dimensions in parenthesis are for reference only. Dimensioning and tolerancing per ASME Y14.5M.
2. This drawing is subject to change without notice.
3. Body length does not include mold flash, protrusions, or gate burrs. Mold flash, protrusions, or gate burrs shall not exceed 0.15 per side.
4. This package falls within JEDEC MO-153.
5. Keep-out features are identified to prevent board routing interference. These exposed metal features may vary within the identified area or completely absent on some devices.

EXAMPLE BOARD LAYOUT
HTSSOP - 1.2 mm max height

PowerPAD™ HTSSOP

DCA0056F

ADVANCE INFORMATION

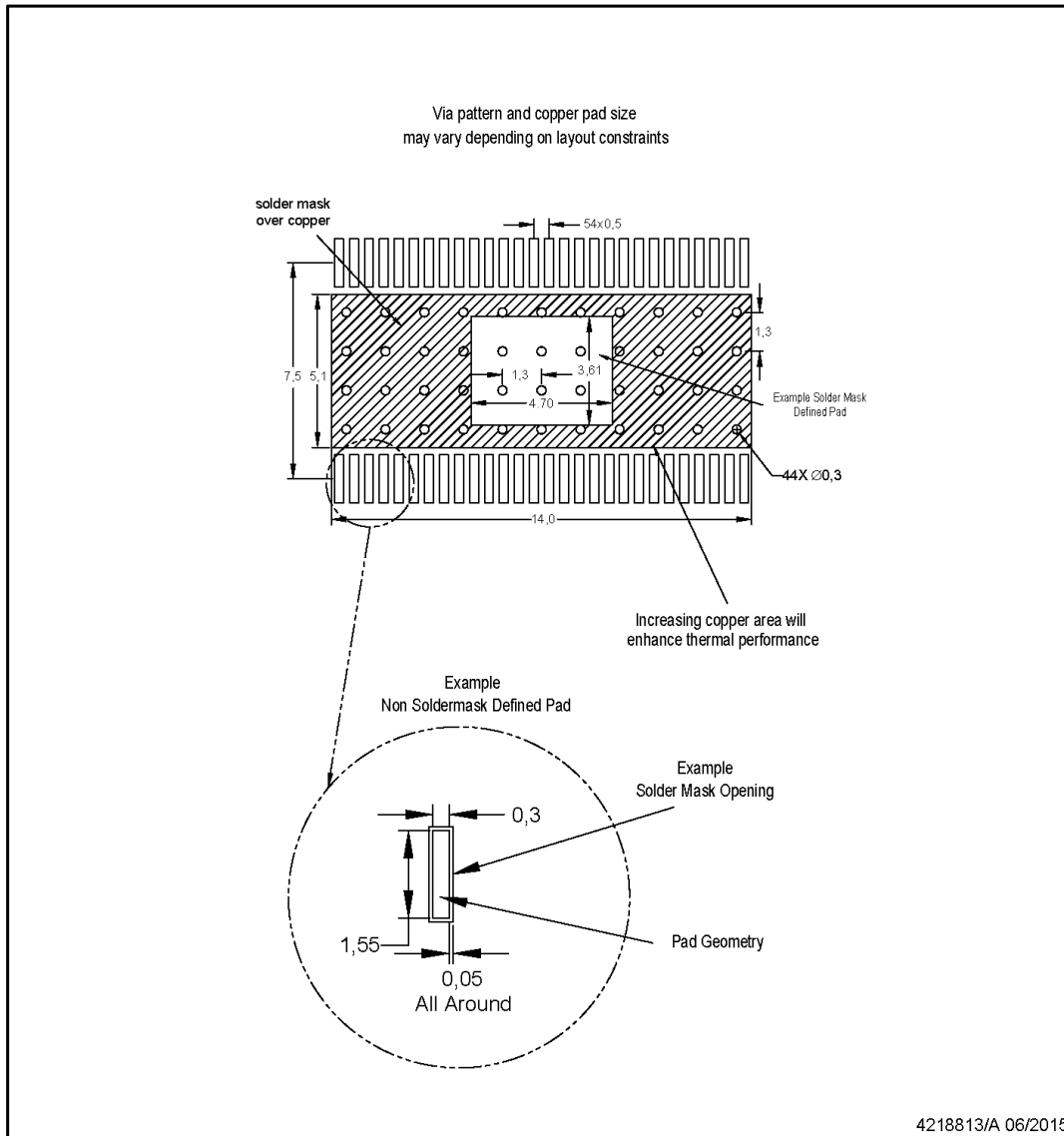

NOTES: (continued)

6. Publication IPC-7351 may have alternate designs.
7. Solder mask tolerances between and around signal pads can vary based on board fabrication site.
8. This package is designed to be soldered to a thermal pad on the board. Refer to technical brief, Powerpad Thermally Enhanced Package, Texas Instruments Literature No. SLMA002 (www.ti.com/lit/slma002) and SLMA004 (www.ti.com/lit/slma004).

EXAMPLE STENCIL DESIGN
HTSSOP - 1.2 mm max height

DCA0056F

PowerPAD™ HTSSOP

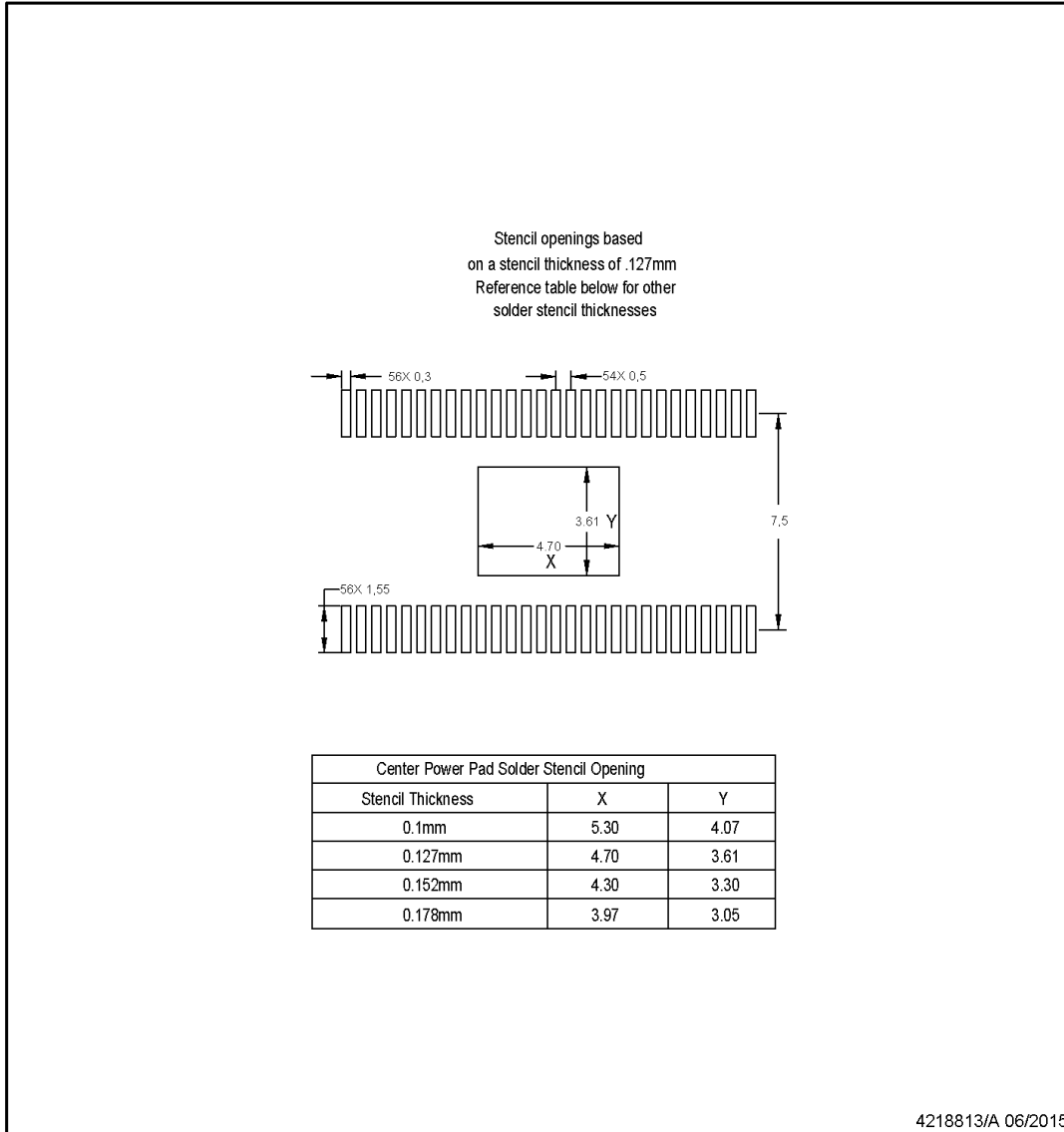

NOTES: (continued)

9. Laser cutting apertures with trapezoidal walls and rounded corners may offer better paste release. IPC-7525 may have alternate design recommendations.
10. Board assembly site may have different recommendations for stencil design.

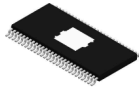

PACKAGE OUTLINE

DFD0056D

PowerPAD™ TSSOP - 1.2 mm max height

PLASTIC SMALL OUTLINE

ADVANCE INFORMATION

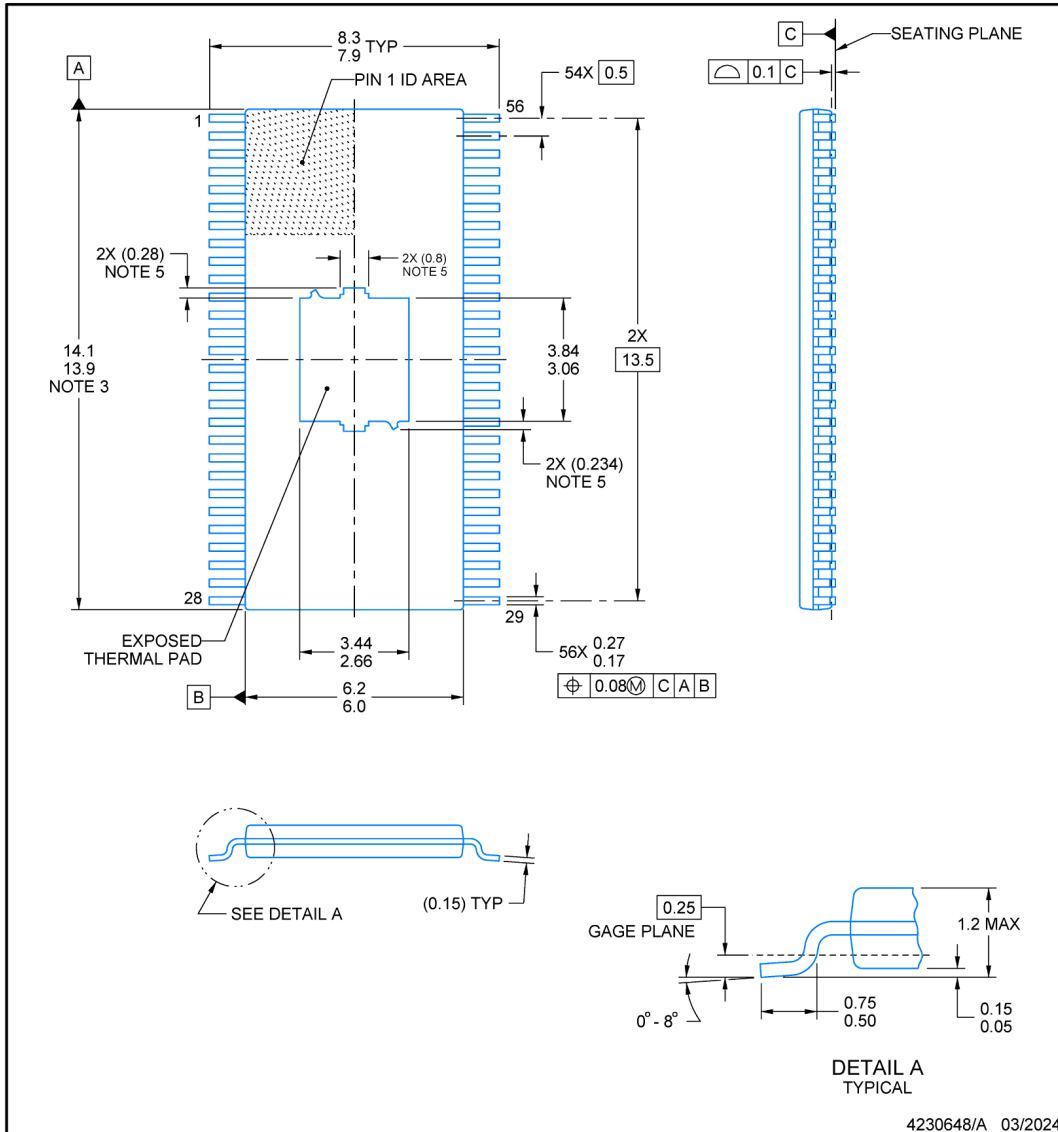

- NOTES:
1. All linear dimensions are in millimeters. Any dimensions in parenthesis are for reference only. Dimensioning and tolerancing per ASME Y14.5M.
 2. This drawing is subject to change without notice.
 3. This dimension does not include mold flash, protrusions, or gate burrs. Mold flash, protrusions, or gate burrs shall not exceed 0.15 mm per side.
 4. Reference JEDEC registration MO-153.
 5. Features may not present.
 6. This package incorporates an exposed thermal pad that is designed to be attached directly to an external heat sink. This optimizes the heat transfer from the integrated circuit (IC).
- PowerPAD is a trademark of Texas Instruments.



EXAMPLE BOARD LAYOUT

DFD0056D

PowerPAD™ TSSOP - 1.2 mm max height

PLASTIC SMALL OUTLINE

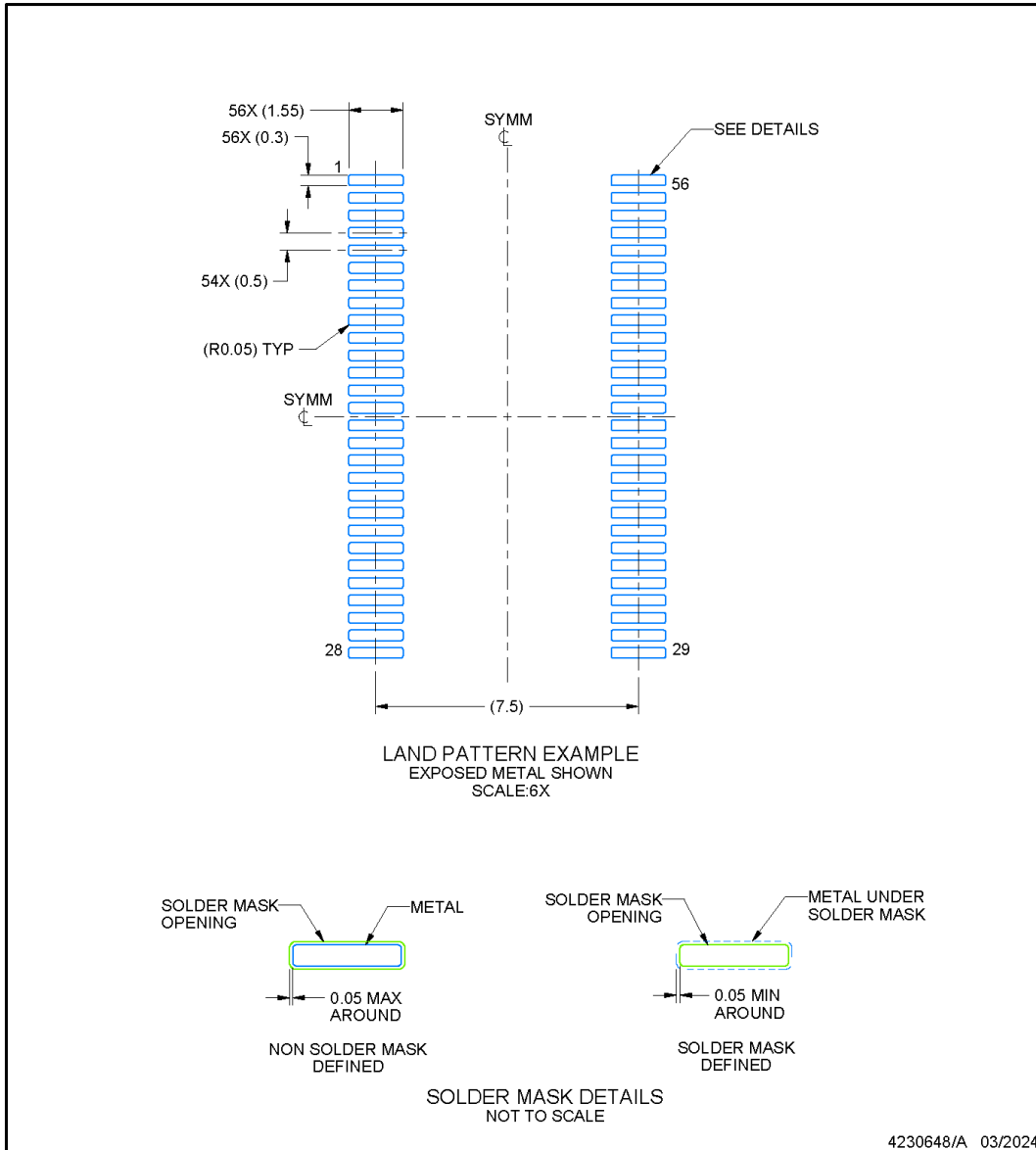

NOTES: (continued)

- 7. Publication IPC-7351 may have alternate designs.
- 8. Solder mask tolerances between and around signal pads can vary based on board fabrication site.

EXAMPLE STENCIL DESIGN
HTSSOP - 1.2 mm max height

DCA0056F

PowerPAD™ HTSSOP

Stencil openings based
on a stencil thickness of .127mm
Reference table below for other
solder stencil thicknesses

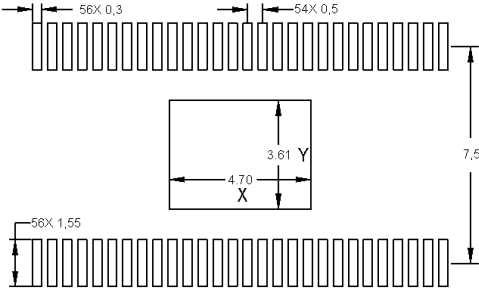

Center Power Pad Solder Stencil Opening		
Stencil Thickness	X	Y
0.1mm	5.30	4.07
0.127mm	4.70	3.61
0.152mm	4.30	3.30
0.178mm	3.97	3.05

4218813/A 06/2015

NOTES: (continued)

9. Laser cutting apertures with trapezoidal walls and rounded corners may offer better paste release. IPC-7525 may have alternate design recommendations.
10. Board assembly site may have different recommendations for stencil design.

7.1 卷带包装信息

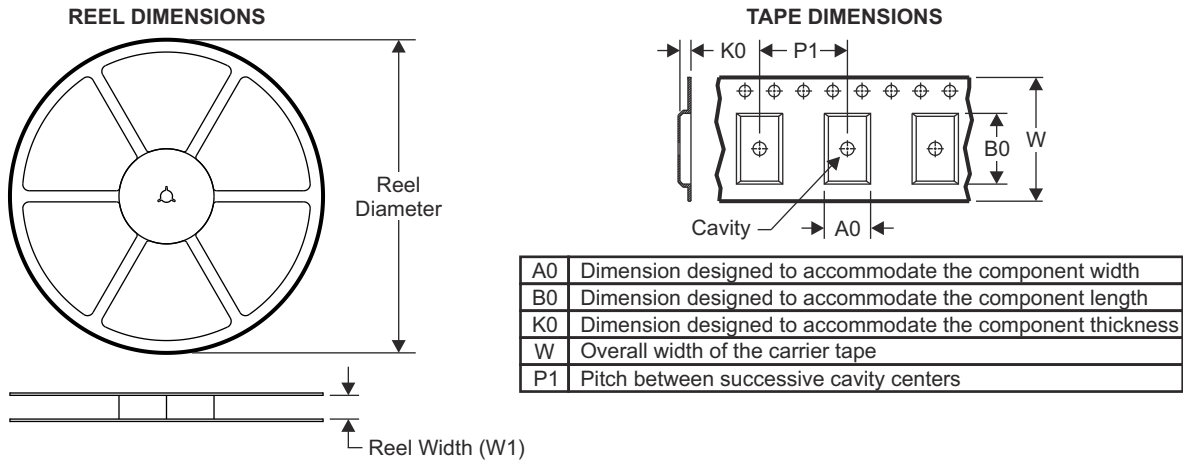

QUADRANT ASSIGNMENTS FOR PIN 1 ORIENTATION IN TAPE

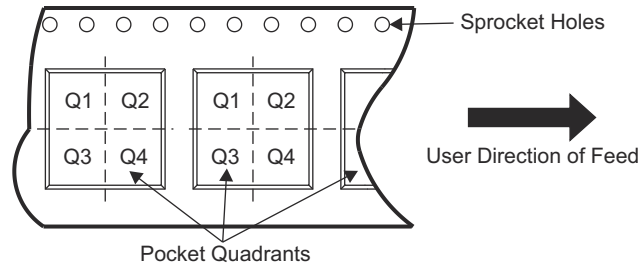

器件	封装类型	封装图	引脚	SPQ	卷带直径 (mm)	卷带宽度 W1 (mm)	A0 (mm)	B0 (mm)	K0 (mm)	P1 (mm)	W (mm)	Pin1 象限
TLC69629QDCARQ1	HTSSOP	DCA	56	2500	330	24.4	8.6	15.6	1.8	12	24	Q1
TLC69629QRTQRQ1	VQFN	RTQ	56	3500	330	16.4	8.3	8.3	1.1	12	16	Q2
TLC69629QDFDRQ1	HTSSOP	DFD	56	2500	330	24.4	8.9	14.7	1.4	12	24	Q1

TAPE AND REEL BOX DIMENSIONS

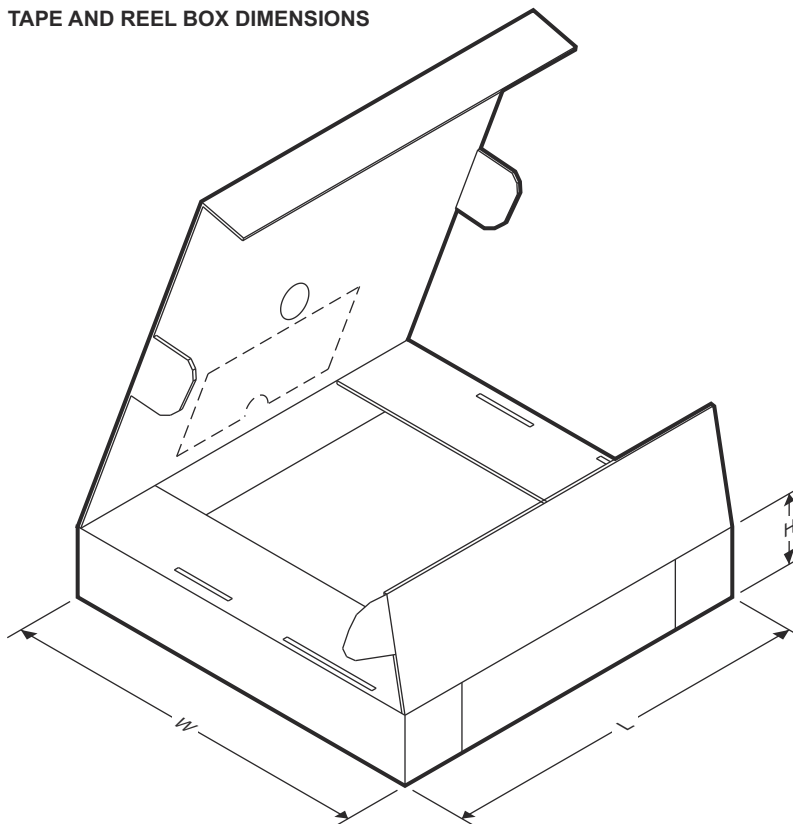

器件	封装类型	封装图	引脚	SPQ	长度 (mm)	宽度 (mm)	高度 (mm)
TLC69629QDCARQ1	HTSSOP	DCA	56	2500	367	367	45
TLC69629QRTQRQ1	VQFN	RTQ	56	3500	367	367	35
TLC69629QDFDRQ1	HTSSOP	DFD	56	2500	350	350	43

ADVANCE INFORMATION

PACKAGING INFORMATION

Orderable Device	Status (1)	Package Type	Package Drawing	Pins	Package Qty	Eco Plan (2)	Lead finish/ Ball material (6)	MSL Peak Temp (3)	Op Temp (°C)	Device Marking (4/5)	Samples
PTLC69629QRTQRQ1	ACTIVE	QFN	RTQ	56	3500	TBD	Call TI	Call TI	-40 to 125		Samples

(1) The marketing status values are defined as follows:

ACTIVE: Product device recommended for new designs.

LIFEBUY: TI has announced that the device will be discontinued, and a lifetime-buy period is in effect.

NRND: Not recommended for new designs. Device is in production to support existing customers, but TI does not recommend using this part in a new design.

PREVIEW: Device has been announced but is not in production. Samples may or may not be available.

OBSELETE: TI has discontinued the production of the device.

(2) **RoHS:** TI defines "RoHS" to mean semiconductor products that are compliant with the current EU RoHS requirements for all 10 RoHS substances, including the requirement that RoHS substance do not exceed 0.1% by weight in homogeneous materials. Where designed to be soldered at high temperatures, "RoHS" products are suitable for use in specified lead-free processes. TI may reference these types of products as "Pb-Free".

RoHS Exempt: TI defines "RoHS Exempt" to mean products that contain lead but are compliant with EU RoHS pursuant to a specific EU RoHS exemption.

Green: TI defines "Green" to mean the content of Chlorine (Cl) and Bromine (Br) based flame retardants meet JS709B low halogen requirements of <=1000ppm threshold. Antimony trioxide based flame retardants must also meet the <=1000ppm threshold requirement.

(3) MSL, Peak Temp. - The Moisture Sensitivity Level rating according to the JEDEC industry standard classifications, and peak solder temperature.

(4) There may be additional marking, which relates to the logo, the lot trace code information, or the environmental category on the device.

(5) Multiple Device Markings will be inside parentheses. Only one Device Marking contained in parentheses and separated by a "-" will appear on a device. If a line is indented then it is a continuation of the previous line and the two combined represent the entire Device Marking for that device.

(6) Lead finish/Ball material - Orderable Devices may have multiple material finish options. Finish options are separated by a vertical ruled line. Lead finish/Ball material values may wrap to two lines if the finish value exceeds the maximum column width.

Important Information and Disclaimer:The information provided on this page represents TI's knowledge and belief as of the date that it is provided. TI bases its knowledge and belief on information provided by third parties, and makes no representation or warranty as to the accuracy of such information. Efforts are underway to better integrate information from third parties. TI has taken and continues to take reasonable steps to provide representative and accurate information but may not have conducted destructive testing or chemical analysis on incoming materials and chemicals. TI and TI suppliers consider certain information to be proprietary, and thus CAS numbers and other limited information may not be available for release.

In no event shall TI's liability arising out of such information exceed the total purchase price of the TI part(s) at issue in this document sold by TI to Customer on an annual basis.

GENERIC PACKAGE VIEW

RTQ 56

VQFN - 1 mm max height

8 x 8, 0.5 mm pitch

PLASTIC QUAD FLATPACK - NO LEAD

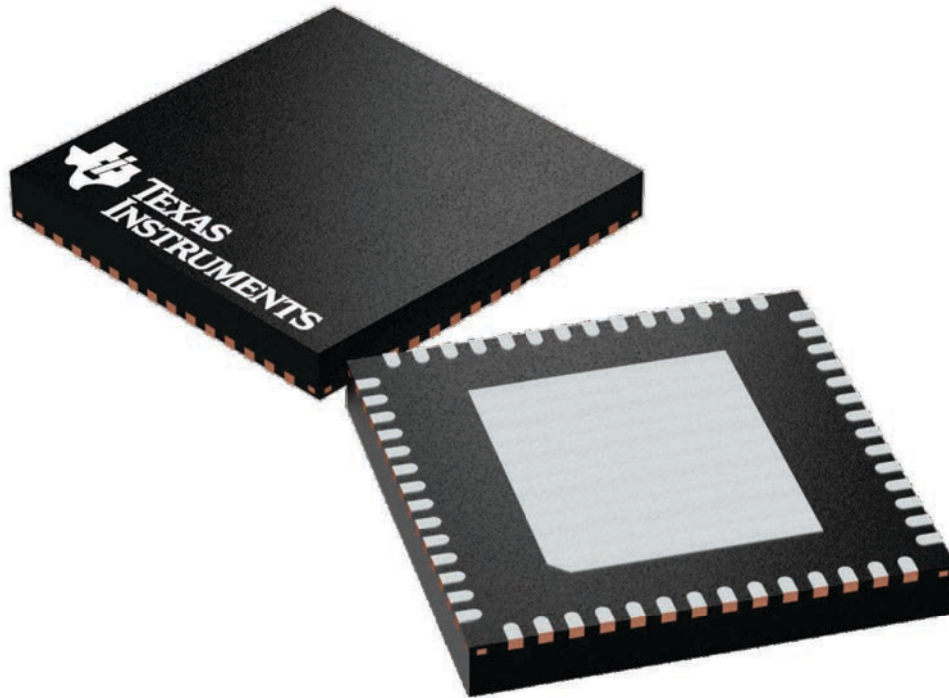

Images above are just a representation of the package family, actual package may vary.
Refer to the product data sheet for package details.

4224653/A

重要通知和免责声明

TI“按原样”提供技术和可靠性数据（包括数据表）、设计资源（包括参考设计）、应用或其他设计建议、网络工具、安全信息和其他资源，不保证没有瑕疵且不做任何明示或暗示的担保，包括但不限于对适销性、某特定用途方面的适用性或不侵犯任何第三方知识产权的暗示担保。

这些资源可供使用 TI 产品进行设计的熟练开发人员使用。您将自行承担以下全部责任：(1) 针对您的应用选择合适的 TI 产品，(2) 设计、验证并测试您的应用，(3) 确保您的应用满足相应标准以及任何其他功能安全、信息安全、监管或其他要求。

这些资源如有变更，恕不另行通知。TI 授权您仅可将这些资源用于研发本资源所述的 TI 产品的相关应用。严禁以其他方式对这些资源进行复制或展示。您无权使用任何其他 TI 知识产权或任何第三方知识产权。您应全额赔偿因在这些资源的使用中对 TI 及其代表造成的任何索赔、损害、成本、损失和债务，TI 对此概不负责。

TI 提供的产品受 [TI 的销售条款](#) 或 [ti.com](#) 上其他适用条款/TI 产品随附的其他适用条款的约束。TI 提供这些资源并不会扩展或以其他方式更改 TI 针对 TI 产品发布的适用的担保或担保免责声明。

TI 反对并拒绝您可能提出的任何其他或不同的条款。

邮寄地址：Texas Instruments, Post Office Box 655303, Dallas, Texas 75265
版权所有 © 2025，德州仪器 (TI) 公司