

采用 WCSP 封装、具有双线制串行接口的 TMP108 低功耗数字温度传感器

1 特性

- 具有欠温和过热警报的动态可编程限制窗口
- 精度：
 - 20°C 至 +85°C 范围内为 $\pm 0.75^\circ\text{C}$ （最大值）
 - 40°C 至 +125°C 范围内为 $\pm 1^\circ\text{C}$ （最大值）
- 低静态电流：
 - 40°C 至 +125°C 范围内为 $6\mu\text{A}$ 有源（最大值）
- 电源电压范围：1.4V 至 3.6V
- 分辨率：12 位 (0.0625°C)
- 封装：1.2mm × 0.8mm，6 焊球 WCSP 封装

2 应用

- 智能手机和平板电脑热管理
- 电池管理
- 恒温器控制
- 欠温和过热保护
- 环境监测和 HVAC

3 说明

TMP108 是一款数字输出温度传感器，具有动态可编程限制窗口和欠温与过热警报功能。这些特性在无需由控制器或应用处理器频繁读取温度的情况下，提供经优化的温度控制。

TMP108 具有 SMBus 和双线制接口兼容性，借助 SMBus 警报功能在一条总线上最多支持 4 个器件。

TMP108 专为各种消费类产品、计算机和环境应用的热管理优化而设计。此器件的额定工作温度范围为 –40°C 至 +125°C。

器件信息⁽¹⁾

器件型号	封装	封装尺寸（标称值）
TMP108	DSBGA (6)	1.20mm × 0.80mm

(1) 如需了解所有可用封装，请参阅数据表末尾的可订购产品附录。

方框图

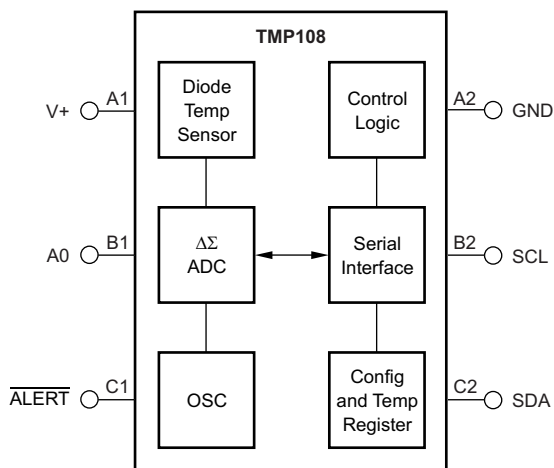

目录

1	特性	1	7.4	Device Functional Modes	11
2	应用	1	7.5	Programming	12
3	说明	1	8	Application and Implementation	17
4	修订历史记录	2	8.1	Application Information	17
5	Pin Configuration and Functions	3	8.2	Typical Application	17
6	Specifications	3	9	Power Supply Recommendations	18
6.1	Absolute Maximum Ratings	3	10	Layout	19
6.2	ESD Ratings	3	10.1	Layout Guidelines	19
6.3	Recommended Operating Conditions	4	10.2	Layout Example	19
6.4	Thermal Information	4	11	器件和文档支持	20
6.5	Electrical Characteristics	4	11.1	接收文档更新通知	20
6.6	Timing Diagrams	5	11.2	支持资源	20
6.7	Typical Characteristics	8	11.3	商标	20
7	Detailed Description	9	11.4	静电放电警告	20
7.1	Overview	9	11.5	Glossary	20
7.2	Functional Block Diagram	9	12	机械、封装和可订购信息	20
7.3	Feature Description	9			

4 修订历史记录

Changes from Original (April 2013) to Revision A	Page
• 已添加 添加了引脚配置和功能 部分、ESD 额定值表、特性 说明 部分、器件功能模式、应用和实施 部分、电源建议 部分、布局 部分、器件和文档支持 部分以及机械、封装和可订购信息 部分	1
• Changed supply voltage maximum value from: 3.6 V to: 4 V	3
• Changed input voltage maximum value for the SDA and SCL pins from: 3.6 V to: 4 V	3
• Changed input voltage maximum value for the A0 and $\overline{\text{ALERT}}$ pins from: (V+) + 0.3 V to: ((V+) + 0.5) and ≤ 4 V	3
• Changed <i>Temperature Error at +25°C</i> graph	8

5 Pin Configuration and Functions

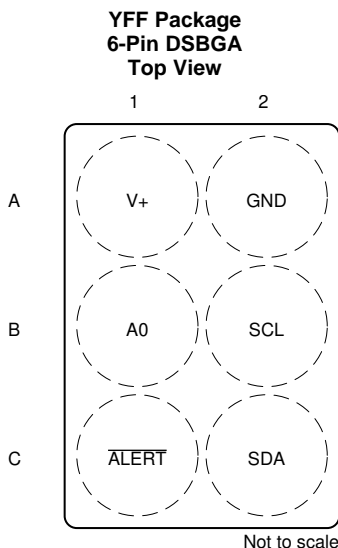

Pin Functions

PIN		I/O	DESCRIPTION
NAME	NO.		
A0	B1	I	Address selection pin. Connect to GND, V+, SDA, or SCL.
$\overline{\text{ALERT}}$	C1	O	Alert output pin
GND	A2	—	Ground
SCL	B2	I	Input clock pin
SDA	C2	I/O	Input/output data pin
V+	A1	I	Supply voltage (1.4 V to 3.6 V)

6 Specifications

6.1 Absolute Maximum Ratings⁽¹⁾

		MIN	MAX	UNIT
Supply voltage			4	V
Input voltage	SDA and SCL ⁽²⁾	-0.5	4	V
	A0 and $\overline{\text{ALERT}}$	-0.5	$((V+) + 0.5)$ and ≤ 4	V
Operating temperature		-55	150	°C
Junction temperature			150	°C
Storage temperature, T _{stg}		-60	150	°C

(1) Stresses beyond those listed under *Absolute Maximum Ratings* may cause permanent damage to the device. These are stress ratings only, which do not imply functional operation of the device at these or any other conditions beyond those indicated under *Recommended Operating Conditions*. Exposure to absolute-maximum-rated conditions for extended periods may affect device reliability.

(2) If A0 is connected to SCL or SDA, the input voltage rating for A0 applies to SCL or SDA.

6.2 ESD Ratings

		VALUE	UNIT
V _(ESD)	Electrostatic discharge	Human-body model (HBM), per ANSI/ESDA/JEDEC JS-001 ⁽¹⁾	±2000
		Charged-device model (CDM), per JEDEC specification JESD22-C101 ⁽²⁾	±1000

(1) JEDEC document JEP155 states that 500-V HBM allows safe manufacturing with a standard ESD control process.

(2) JEDEC document JEP157 states that 250-V CDM allows safe manufacturing with a standard ESD control process.

6.3 Recommended Operating Conditions

		MIN	MAX	UNIT
V+	Supply voltage	1.4	3.6	V
T _A	Operating free-air temperature	-40	+125	°C

6.4 Thermal Information

THERMAL METRIC		TMP108		UNIT
		YFF (DSBGA)		
		6 PINS		
θ _{JA}	Junction-to-ambient thermal resistance	132.7		°C/W
θ _{JC(top)}	Junction-to-case(top) thermal resistance	1.7		°C/W
θ _{JB}	Junction-to-board thermal resistance	23		°C/W
ψ _{JT}	Junction-to-top characterization parameter	6		°C/W
ψ _{JB}	Junction-to-board characterization parameter	22.6		°C/W
θ _{JC(bottom)}	Junction-to-case(bottom) thermal resistance	N/A		°C/W

6.5 Electrical Characteristics

At T_A = +25°C, and V+ = +1.8 V, unless otherwise noted.

PARAMETER	TEST CONDITIONS	MIN	TYP	MAX	UNIT	
TEMPERATURE INPUT						
Range		-40		+125	°C	
Accuracy (temperature error)	-20°C to +85°C	-0.75	±0.15	0.75	°C	
	-40°C to +125°C	-1	±0.3	1	°C	
Accuracy vs supply		-0.3	±0.03	0.3	°C/V	
DIGITAL INPUT/OUTPUT						
V _{IH}	Input logic high level	0.7 (V+)		V+	V	
V _{IL}	Input logic low level	-0.5		0.3 (V+)	V	
I _{IN}	Input current	0 V < V _{IN} < (V+) +0.3 V		1	μA	
V _{OL}	Output logic low level	V+ > 2 V, I _{OUT} = 3 mA		0.4	V	
		V+ < 2 V, I _{OUT} = 3 mA		0.2 (V+)	V	
	$\overline{\text{ALERT}}$ internal pullup resistor	80	100	120	kΩ	
	Resolution	12			Bit	
	Conversion time	21	27	33	ms	
Conversion modes	CR1 = 0, CR0 = 0	0.25			Conv/s	
	CR1 = 0, CR0 = 1 (default)	1			Conv/s	
	CR1 = 1, CR0 = 0	4			Conv/s	
	CR1 = 1, CR0 = 1	16			Conv/s	
	Timeout time	21	28	35	ms	
POWER SUPPLY						
I _Q	Quiescent current	Serial bus inactive, CR1 = 0, CR0 = 1 (default)		2	3.5	μA
		Serial bus inactive, CR1 = 0, CR0 = 1 (default), -40°C to +125°C		6		μA
		Serial bus active, SCL frequency = 400 kHz, CR1 = 0, CR0 = 1 (default)		12		μA
		Serial bus active, SCL frequency = 3.4 MHz, CR1 = 0, CR0 = 1 (default)		82		μA
I _{SD}	Shutdown current	Serial bus inactive		0.3	1	μA
		Serial bus active, SCL frequency = 400 kHz		10		μA
		Serial bus active, SCL frequency = 3.4 MHz		80		μA

6.6 Timing Diagrams

The TMP108 is two-wire and SMBus compatible. [Figure 1](#) to [Figure 4](#) describe the various operations on the TMP108. Parameters for [Figure 1](#) are defined in [Table 1](#). Bus definitions are:

Bus Idle: Both SDA and SCL lines remain high.

Start Data Transfer: A change in the state of the SDA line, from high to low, while the SCL line is high defines a start condition. Each data transfer is initiated with a start condition.

Stop Data Transfer: A change in the state of the SDA line from low to high while the SCL line is high defines a stop condition. Each data transfer is terminated with a repeated start or stop condition.

Data Transfer: The number of data bytes transferred between a start and a stop condition is not limited, and is determined by the master device. The receiver acknowledges the transfer of data. It is also possible to use the TMP108 for single-byte updates. To update only the MS byte, terminate communication by issuing a start or stop condition on the bus.

Acknowledge: Each receiving device, when addressed, must generate an acknowledge bit. A device that acknowledges must pull down the SDA line during the acknowledge clock pulse so that the SDA line is stable low during the high period of the acknowledge clock pulse. Setup and hold times must be taken into account. When a master receives data, the termination of the data transfer can be signaled by the master generating a *not-acknowledge* (1) on the last byte transmitted by the slave.

Table 1. Timing Diagram Definitions

		FAST MODE		HIGH-SPEED MODE		UNIT
		MIN	MAX	MIN	MAX	
$f_{(SCL)}$	SCL operating frequency, $V+ \geq 1.8$ V	0.001	0.4	0.001	3.4	MHz
	SCL operating frequency, $V+ < 1.8$ V	0.001	0.4	0.001	2.5	MHz
$t_{(BUF)}$	Bus free time between stop and start conditions, $V+ \geq 1.8$ V	1300		160		ns
	Bus free time between stop and start conditions, $V+ < 1.8$ V	1300		260		ns
$t_{(HDSTA)}$	Hold time after repeated start condition. After this period, the first clock is generated.	600		160		ns
$t_{(SUSTA)}$	Repeated start condition setup time	600		160		ns
$t_{(SUSTO)}$	Stop condition setup time	600		160		ns
$t_{(HDDAT)}$	Data hold time, $V+ \geq 1.8$ V	0	900	0	70	ns
	Data hold time, $V+ < 1.8$ V	0	900	0	130	ns
$t_{(SUDAT)}$	Data setup time, $V+ \geq 1.8$ V	100		10		ns
	Data setup time, $V+ < 1.8$ V	100		50		ns
$t_{(LOW)}$	SCL clock low period, $V+ \geq 1.8$ V	1300		160		ns
	SCL clock low period, $V+ < 1.8$ V	1300		260		ns
$t_{(HIGH)}$	SCL clock high period	600		60		ns
t_R, t_F - SDA	Data rise/fall time		300		80	ns
t_R, t_F - SCL	Clock rise/fall time		300		40	ns
t_R	Clock/data rise time for $SCLK \leq 100$ kHz		1000			ns

6.6.1 Two-Wire Timing Diagrams

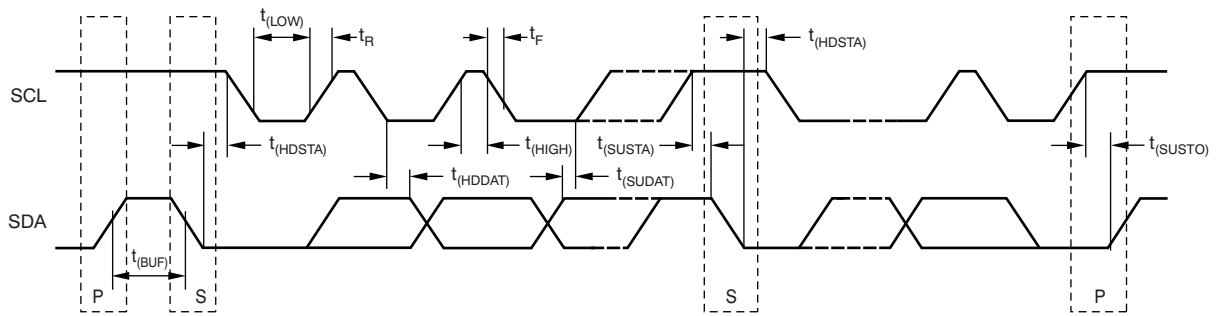
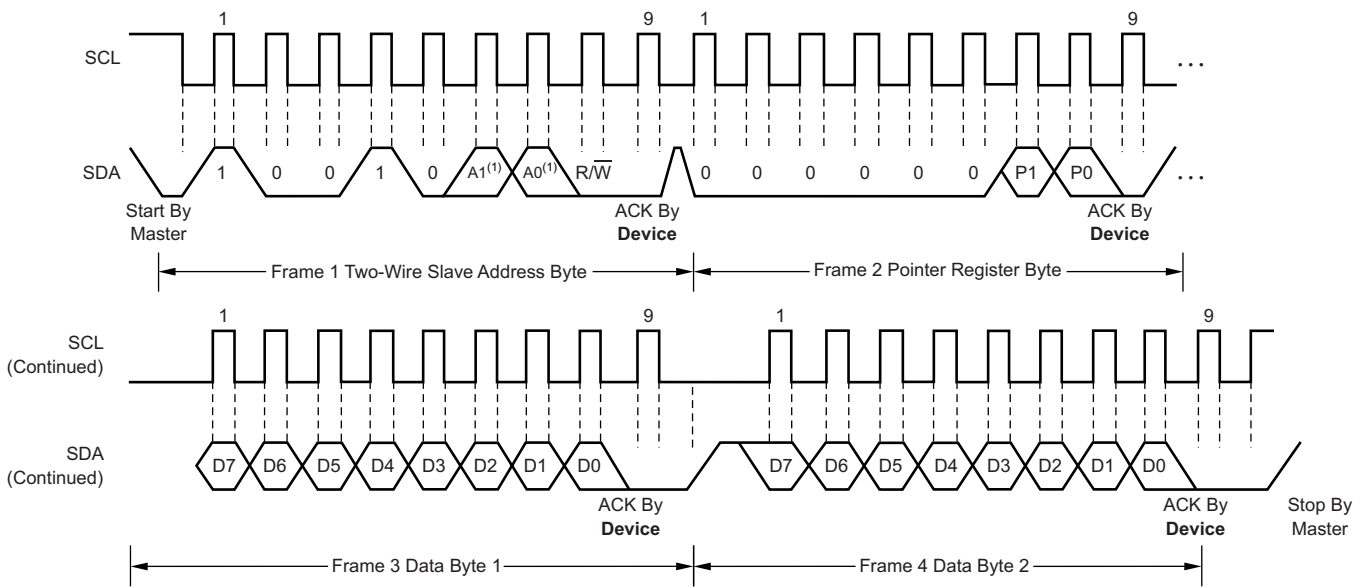
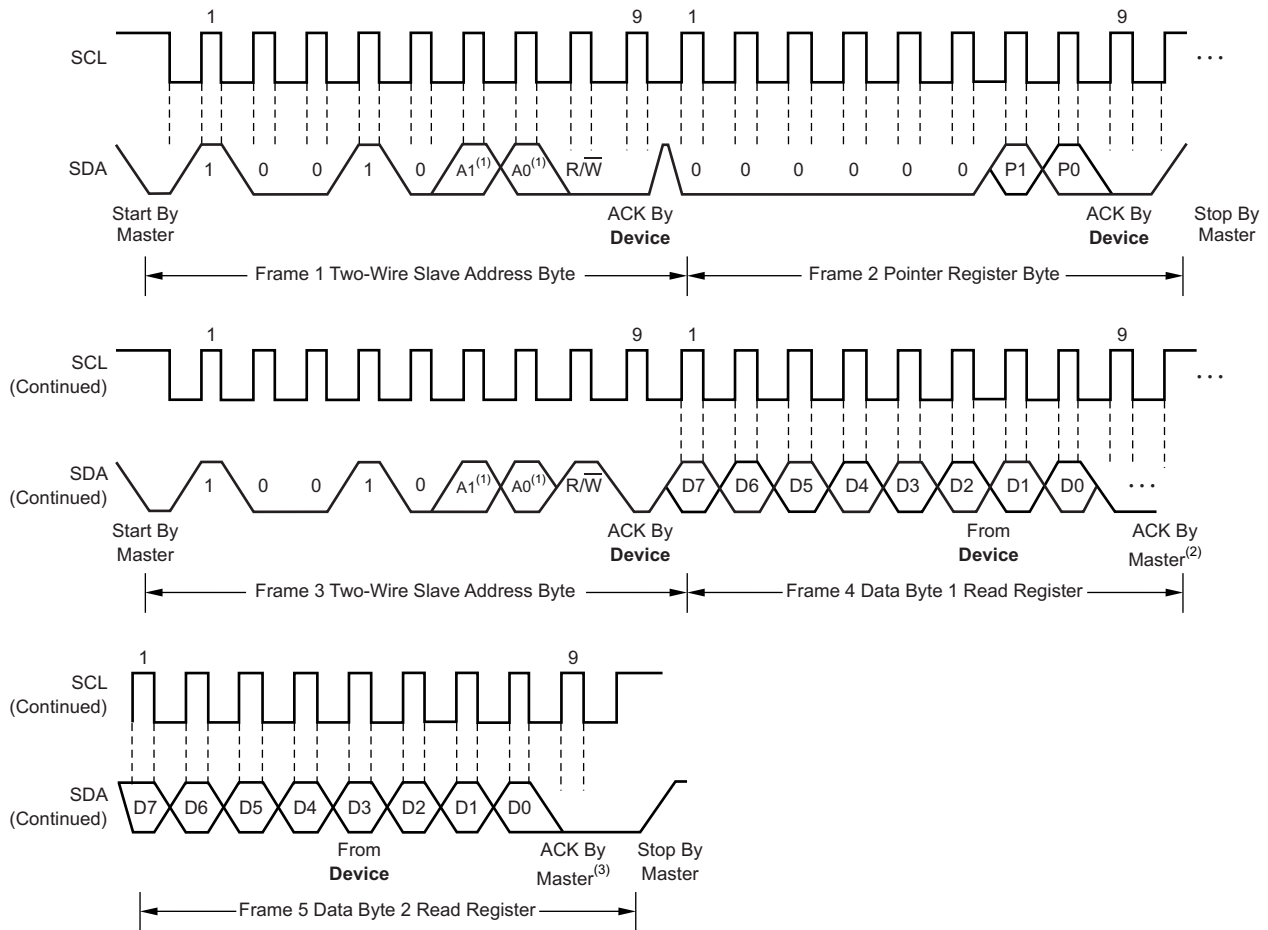

Figure 1. Two-Wire Timing Diagram



(1) The value of A0 and A1 are determined by the A0 pin.

Figure 2. Two-Wire Timing Diagram for Write Word Format



- (1) The value of A0 and A1 are determined by the A0 pin.
- (2) Master should leave SDA high to terminate a single-byte read operation.
- (3) Master should leave SDA high to terminate a two-byte read operation.

Figure 3. Two-Wire Timing Diagram for Read Word Format

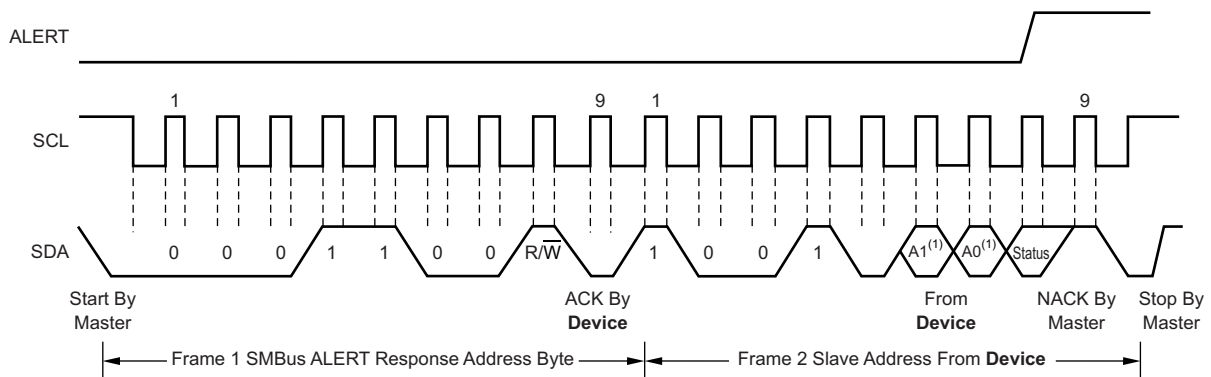

- (1) The value of A0 and A1 are determined by the A0 pin.

Figure 4. Timing Diagram for SMBus Alert

6.7 Typical Characteristics

At $T_A = +25^\circ\text{C}$ and $V_+ = 1.8\text{ V}$, unless otherwise noted.

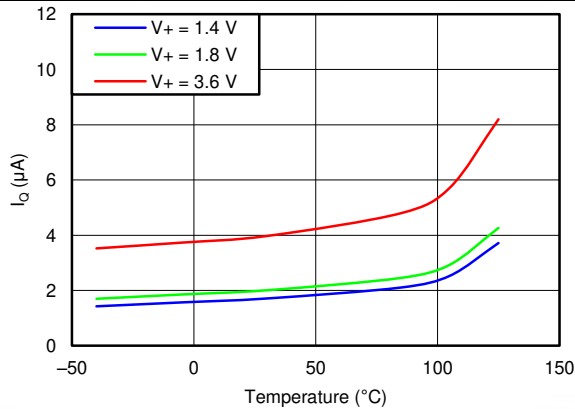

Figure 5. Quiescent Current vs Temperature (1 Conversion per Second)

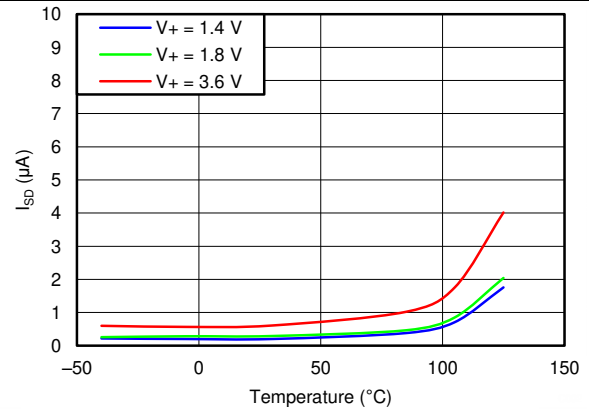

Figure 6. Shutdown Current vs Temperature

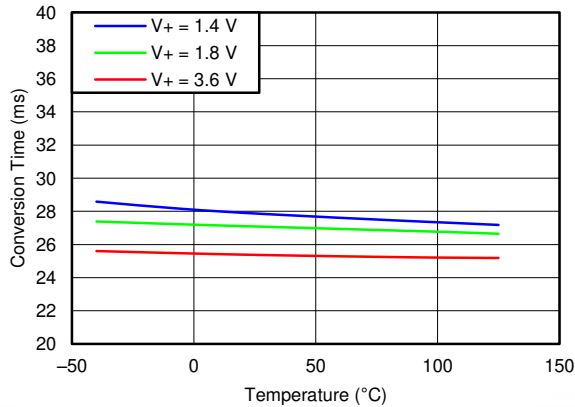

Figure 7. Conversion Time vs Temperature

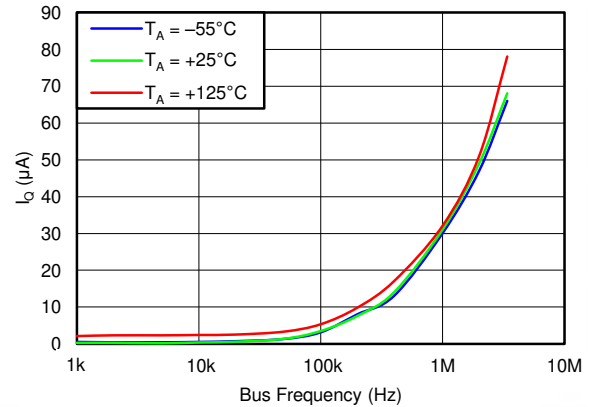

Figure 8. Quiescent Current vs Bus Frequency

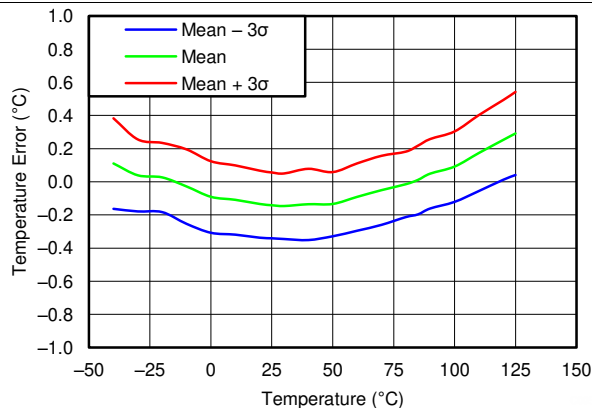

Figure 9. Temperature Error vs Temperature

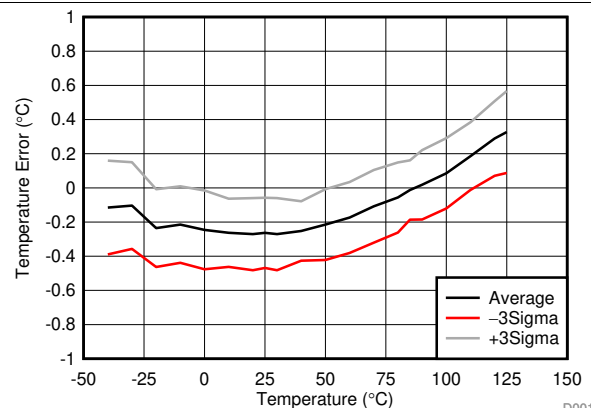

Figure 10. Temperature Error at +25°C

7 Detailed Description

7.1 Overview

The TMP108 is a digital temperature sensor optimal for thermal management and thermal protection applications. The TMP108 is two-wire and SMBus Interface compatible, and is specified over a temperature range of -40°C to $+125^{\circ}\text{C}$.

The TMP108 temperature sensor is the chip itself. The solder bumps provide the primary thermal path as a result of the lower thermal resistance of metal. The temperature sensor result is equivalent to the local temperature of the printed-circuit board (PCB) on which the sensor is mounted.

7.2 Functional Block Diagram

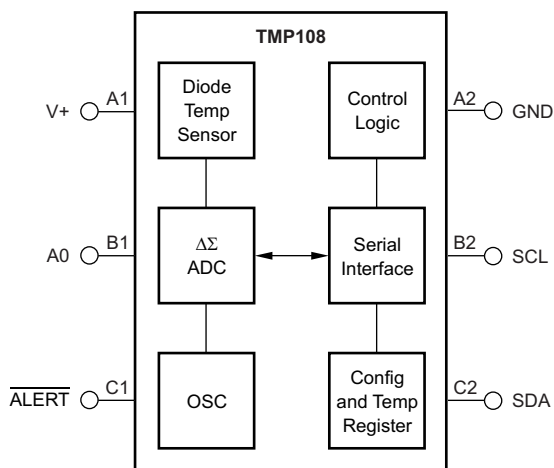

7.3 Feature Description

7.3.1 Serial Interface

The TMP108 operates as a slave device only on the two-wire bus and SMBus. Connections to the bus are made using the open-drain I/O lines, SDA and SCL. The SDA and SCL pins feature integrated spike-suppression filters and Schmitt triggers to minimize the effects of input spikes and bus noise. The TMP108 supports the transmission protocol for both fast (1 kHz to 400 kHz) and high-speed (1 kHz to 3.4 MHz) modes. All data bytes are transmitted MSB first.

7.3.2 Serial Bus Address

To communicate with the TMP108, the master must first communicate with slave devices using a slave address byte. The slave address byte consists of seven address bits, and a direction bit indicating the intent of executing either a read or write operation. The TMP108 features an address pin that allows up to four devices to be addressed on a single bus. The TMP108 latches the status of the address pin at the start of a communication. [Table 2](#) describes the pin logic levels and the corresponding address values. Other values for the fixed address bits are available by request.

Table 2. Address Pin and Slave Addresses

DEVICE TWO-WIRE ADDRESS		A0 PIN CONNECTION
TMP108		
1001000		Ground
1001001		V+
1001010		SDA
1001011		SCL

7.3.3 Bus Overview

The device that initiates the transfer is called a *master*, and the devices controlled by the master are *slaves*. The bus must be controlled by a master device that generates the serial clock (SCL), controls the bus access, and generates the start and stop conditions.

To address a specific device, initiate a start condition by pulling the data line (SDA) from a high to a low logic level while SCL is high. All slaves on the bus shift in the slave address byte, and the last bit indicates whether a read or write operation follows. During the ninth clock pulse, the slave being addressed responds to the master by generating an acknowledge bit and pulling SDA low.

Data transfer is then initiated and sent over eight clock pulses followed by an acknowledge bit. During data transfer, SDA must remain stable while SCL is high because any change in SDA while SCL is high is interpreted as a start or stop signal.

After all data have been transferred, the master generates a stop condition indicated by pulling SDA from low to high, while SCL is high.

7.3.4 Writing and Reading Operation

Accessing a particular register on the TMP108 is accomplished by writing the appropriate value to the pointer register. The value for the pointer register is the first byte transferred after the slave address byte with the R/\overline{W} bit low. Every write operation to the TMP108 requires a value for the pointer register (see [Figure 2](#)).

When reading from the TMP108, the last value stored in the pointer register by a write operation is used to determine which register is read by a read operation. To change the register pointer for a read operation, a new value must be written to the pointer register. This action is accomplished by issuing a slave address byte with the R/\overline{W} bit low, followed by the pointer register byte. No additional data are required. The master can then generate a start condition and send the slave address byte with the R/\overline{W} bit high to initiate the read command. See [Figure 3](#) for details of this sequence. If repeated reads from the same register are desired, it is not necessary to continually send the pointer register bytes because the TMP108 stores the pointer register value until it is changed by the next write operation.

Note that register bytes are sent with the most significant byte first, followed by the least significant byte.

7.3.5 Slave Mode Operations

The TMP108 can operate as a slave receiver or slave transmitter.

7.3.5.1 Slave Receiver Mode:

The first byte transmitted by the master is the slave address, with the R/\overline{W} bit low. The TMP108 then acknowledges reception of a valid address. The next byte transmitted by the master is the pointer register. The TMP108 then acknowledges reception of the pointer register byte. The next byte or bytes are written to the register addressed by the pointer register. The TMP108 acknowledges reception of each data byte. The master can terminate data transfer by generating a start or stop condition.

7.3.5.2 Slave Transmitter Mode:

The first byte transmitted by the master is the slave address, with the R/\overline{W} bit high. The slave acknowledges reception of a valid slave address. The next byte is transmitted by the slave and is the most significant byte of the register indicated by the pointer register. The master acknowledges reception of the data byte. The next byte transmitted by the slave is the least significant byte. The master acknowledges reception of the data byte. The master can terminate data transfer by generating a not-acknowledge bit on reception of any data byte, or by generating a start or stop condition.

7.3.6 SMBus Alert Function

The TMP108 supports the SMBus alert function. When the TMP108 operates in interrupt mode ($TM = 1$), the ALERT pin may be connected as an SMBus alert signal. When a master senses that an alert condition is present on the ALERT line, the master sends an SMBus alert command (00011001) to the bus. If the ALERT pin is active, the device acknowledges the SMBus alert command and responds by returning its slave address on the SDA line. The eighth bit (LSB) of the slave address byte indicates whether the alert condition is caused by the temperature exceeding T_{HIGH} or falling below T_{LOW} . The LSB is high if the temperature is greater than T_{HIGH} , or low if the temperature is less than T_{LOW} . See [Figure 4](#) for details of this sequence.

If multiple devices on the bus respond to the SMBus alert command, arbitration during the slave address portion of the SMBus alert command determines which device clears its alert status first. If the TMP108 wins the arbitration, its ALERT pin becomes inactive at the completion of the SMBus alert command. If the TMP108 loses the arbitration, its ALERT pin remains active.

7.3.7 General Call

The TMP108 responds to a two-wire general call address (0000000) if the eighth bit is 0. The device acknowledges the general call address and responds to commands in the second byte. If the second byte is 00000100, the TMP108 latches the status of the address pin, but does not reset. If the second byte is 00000110, the TMP108 internal registers are reset to power-up values. The TMP108 does not support the general address acquire command.

7.3.8 High-Speed (Hs) Mode

In order for the two-wire bus to operate at frequencies above 400 kHz, the master device must issue an SMBus Hs-mode master code (00001xxx) as the first byte after a start condition to switch the bus to high-speed operation. The TMP108 does not acknowledge this byte, but does switch its input filters on SDA and SCL and its output filters on SDA to operate in Hs-mode, allowing transfers at up to 3.4 MHz. After the Hs-mode master code has been issued, the master transmits a two-wire slave address to initiate a data-transfer operation. The bus continues to operate in Hs-mode until a stop condition occurs on the bus. Upon receiving the stop condition, the TMP108 switches the input and output filters back to fast-mode operation.

7.3.9 Timeout Function

The TMP108 resets the serial interface if SCL or SDA are held low for 28 ms (typical) between a start and stop condition. If the TMP108 is pulled low, it releases the bus and then waits for a start condition. To avoid activating the timeout function, it is necessary to maintain a communication speed of at least 1 kHz for the SCL operating frequency.

7.4 Device Functional Modes

The mode bits, M1 and M0, can be set to three different modes: shutdown, one-shot, or continuous conversion.

7.4.1 Shutdown Mode (M1 = 0, M0 = 0)

Shutdown mode saves power by shutting down all device circuitry other than the serial interface, thus reducing current consumption to typically less than 0.5 μ A. Shutdown mode is enabled when M1 and M0 = 00. The device shuts down when current conversion is completed.

7.4.2 One-Shot Mode (M1 = 0, M0 = 1)

The TMP108 features a *one-shot* temperature measurement mode. When the device is in shutdown mode, writing a '01' to the M1 and M0 bits starts a single temperature conversion. During the conversion, the M1 and M0 bits reads 01. The device returns to the shutdown state at the completion of the single conversion. After the conversion, the M1 and M0 bits read 00. This feature is useful for reducing the power consumption of the TMP108 when continuous temperature monitoring is not required.

As a result of the short conversion time, the TMP108 can achieve a higher conversion rate. A single conversion typically takes 27 ms and a read can take place in less than 20 μ s. However, when using one-shot mode, 30 or more conversions per second are possible.

7.4.3 Continuous Conversion Mode (M1 = 1)

When the TMP108 is in continuous conversion mode (M1 = 1), a single conversion is performed at a rate determined by the conversion rate bits (CR1 and CR0 in the configuration register). The TMP108 performs a single conversion, and then goes in standby and waits for the appropriate delay set by the CR1 and CR0 bits. See [Table 10](#) for CR1 and CR0 settings.

7.5 Programming

7.5.1 Pointer Register

Figure 11 shows the internal register structure of the TMP108. Use the 8-bit pointer register to address a given data register. The pointer register uses the two LSBs (see Table 12) to identify which of the data registers respond to a read or write command. Table 3 identifies the bits of the pointer register byte. Table 4 describes the pointer address of the registers available in the TMP108. The power-up reset value of the P1 and P0 bits is 00.

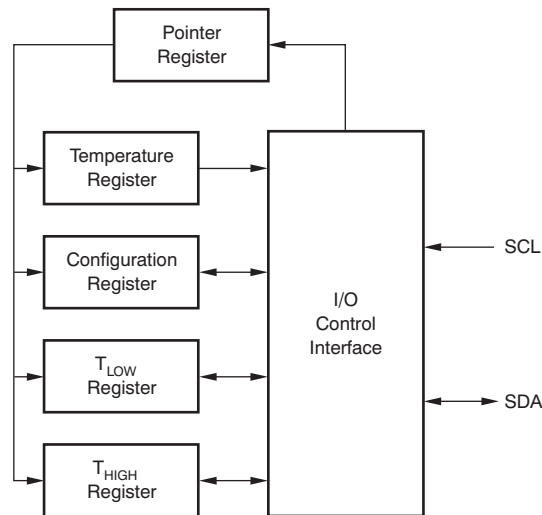

Figure 11. Internal Register Structure

Table 3. Pointer Register Byte

P7	P6	P5	P4	P3	P2	P1	P0
0	0	0	0	0	0	Register Bits	

Table 4. Pointer Addresses

P1	P0	REGISTER
0	0	Temperature register (read only, default)
0	1	Configuration register (read/write)
1	0	T _{LOW} register (read/write)
1	1	T _{HIGH} register (read/write)

7.5.2 Temperature Register

The temperature register is configured as a 12-bit, read-only register that stores the output of the most recent conversion. Two bytes must be read to obtain data, as shown in Table 5 and Table 6. Note that byte 1 is the most significant byte, followed by byte 2, the least significant byte. The first 12 bits are used to indicate temperature. There is no requirement to read the least significant byte if that information is not needed (for example, for resolution lower than 1°C). Table 7 summarizes the temperature data format. One LSB equals 0.0625°C. Negative numbers are represented in binary twos complement format. Following power-up or reset, the temperature register reads 0°C until the first conversion is complete. The unused bits in the temperature register always read 0.

Table 5. Byte 1 of Temperature Register

D7	D6	D5	D4	D3	D2	D1	D0
T11	T10	T9	T8	T7	T6	T5	T4

Table 6. Byte 2 of Temperature Register

D7	D6	D5	D4	D3	D2	D1	D0
T3	T2	T1	T0	0	0	0	0

Table 7. Temperature Data Format⁽¹⁾

TEMPERATURE (°C)	DIGITAL OUTPUT	
	BINARY	HEX
128	0111 1111 1111	7FF
127.9375	0111 1111 1111	7FF
100	0110 0100 0000	640
80	0101 0000 0000	500
75	0100 1011 0000	4B0
50	0011 0010 0000	320
25	0001 1001 0000	190
0.25	0000 0000 0100	004
0	0000 0000 0000	000
-0.25	1111 1111 1100	FFC
-25	1110 0111 0000	E70
-55	1100 1001 0000	C90

(1) The temperature sensor ADC resolution is 0.0625°C/count.

Table 7 does not supply a full list of all temperatures. Use the following rules to obtain the digital data format for a given temperature.

To convert positive temperatures to a digital data format:

Divide the temperature by the resolution. Then, convert the result to binary code with a 12-bit, left-justified format, and MSB = 0 to denote a positive sign.

Example: $(+50^{\circ}\text{C}) / (0.0625^{\circ}\text{C}/\text{count}) = 800 = 320\text{h} = 0011\ 0010\ 0000$

To convert negative temperatures to a digital data format:

Divide the absolute value of the temperature by the resolution, and convert the result to binary code with a 12-bit, left-justified format. Then, generate the twos complement of the result by complementing the binary number and adding one. Denote a negative number with MSB = 1.

Example: $(|-25^{\circ}\text{C}|) / (0.0625^{\circ}\text{C}/\text{count}) = 400 = 190\text{h} = 0001\ 1001\ 0000$

Twos complement format: $1110\ 0110\ 1111 + 1 = 1110\ 0111\ 0000$

7.5.3 Configuration Register

The configuration register is a 16-bit read and write register used to store bits that control the operational modes of the temperature sensor. Read and write operations are performed MSB first. The format and power-up (reset) default value of the configuration register is shown in Table 8, followed by an explanation of the register bits. Other options for the default values are available by request.

Table 8. Configuration and Power-Up/Reset Format

BYTE	D7	D6	D5	D4	D3	D2	D1	D0
1	ID	CR1	CR0	FH	FL	TM	M1	M0
	0	0	1	0	0	0	1	0
2	POL	0	HYS1	HYS0	0	0	0	0
	0	0	0	1	0	0	0	0

7.5.3.1 Hysteresis Control (HYS1 and HYS0)

When operating in comparator mode, the hysteresis control bits (HYS1 and HYS0) configure the hysteresis for the limit comparison of the TMP108 to 0°C, 1°C, 2°C, or 4°C. The default hysteresis is 1°C. Table 9 shows the settings for HYS1 and HYS0.

Table 9. Hysteresis Settings

HYS1	HYS0	HYSTERESIS
0	0	0°C
0	1	1°C (default)
1	0	2°C
1	1	4°C

7.5.3.2 Polarity (POL)

The polarity of the $\overline{\text{ALERT}}$ pin can be programmed using the POL bit. If POL = 0 (default), the $\overline{\text{ALERT}}$ is active low. For POL = 1, the $\overline{\text{ALERT}}$ pin is active high, and the state of the $\overline{\text{ALERT}}$ pin is inverted.

7.5.3.3 Thermostat Mode (TM)

The thermostat mode bit indicates to the device whether to operate in comparator mode (TM = 0, default) or interrupt mode (TM = 1). For more information on comparator and interrupt modes, see the [High- and Low-Limit Registers](#) section.

7.5.3.4 Temperature Watchdog Flags (FL and FH)

The TMP108 uses temperature watchdog flags in the configuration register that indicate the result of comparing the device temperature at the end of every conversion to the values stored in the temperature limit registers (T_{HIGH} and T_{LOW}). If the temperature of the TMP108 exceeds the value in the T_{HIGH} register, then the flag-high bit (FH) in the configuration register is set to 1. If the temperature falls below the value in the T_{LOW} register, then the flag-low bit (FL) is set to 1. If both flag bits remain 0, then the temperature is within the temperature range set by the temperature limit registers. In interrupt mode, when any of the flags is set by an under- or overtemperature event, the SMBus ALERT Response only clears the pin and not the flags. Reading the configuration register clears both the flags and the pin.

7.5.3.5 Conversion Rate

The conversion rate bits, CR1 and CR0, configure the TMP108 for conversion rates of 0.25 Hz, 1 Hz, 4 Hz, or 16 Hz. The default rate is 1 Hz. The TMP108 has a typical conversion time of 27 ms. To achieve different conversion rates, the TMP108 makes a conversion, and then powers down and waits for the appropriate delay set by CR1 and CR0. [Table 10](#) shows the settings for CR1 and CR0.

Table 10. Conversion Rate Settings

CR1	CR0	CONVERSION RATE	I_q (TYP)
0	0	0.25 Hz	1 μA
0	1	1 Hz (default)	2 μA
1	0	4 Hz	5 μA
1	1	16 Hz	18 μA

After power-up or a general-call reset, the TMP108 immediately starts a conversion, as shown in Figure 12. The first result is available after 27 ms (typical). The active quiescent current during conversion is 40 μA (typical at +25°C). The quiescent current during delay is 0.7 μA (typical at +25°C).

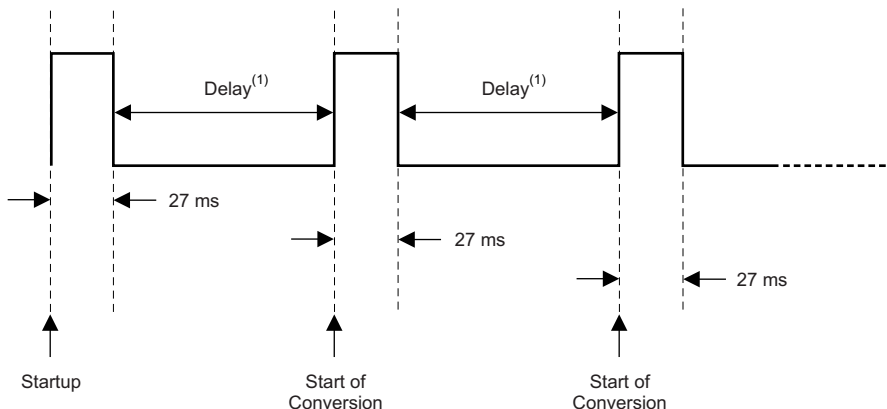

(1) Delay is set by the CR1 and CR0 bits in the configuration register.

Figure 12. Conversion Start

7.5.4 High- and Low-Limit Registers

In comparator mode (TM = 0), the $\overline{\text{ALERT}}$ pin becomes active when the temperature exceeds the value in the T_{HIGH} register or drops below the value in the T_{LOW} register. The $\overline{\text{ALERT}}$ pin remains active until the temperature returns to a value that is within the range set by:

$$(T_{\text{LOW}} + \text{HYS}) \text{ and } (T_{\text{HIGH}} - \text{HYS})$$

where

- HYS is the hysteresis set by the hysteresis control bits (HYS1 and HYS0). (1)

In interrupt mode (TM = 1), the $\overline{\text{ALERT}}$ pin becomes active when the temperature exceeds the value in the T_{HIGH} register or drops below the value in the T_{LOW} register, and remains active until a read operation of the configuration register occurs (also clears the values latched in the watchdog flags, FL and FH), or the device successfully responds to the SMBus alert response address. The $\overline{\text{ALERT}}$ pin is also cleared by resetting the device with the general call reset command.

Both operational modes are represented in Figure 13 and Figure 14.

Table 11 and Table 12 describe the format for the T_{HIGH} and T_{LOW} registers. Note that the most significant byte is sent first, followed by the least significant byte. Power-up (reset) default values are $T_{\text{HIGH}} = +127.9375^\circ\text{C}$ (0x7FF8) and $T_{\text{LOW}} = -128^\circ\text{C}$ (0x8000). These values ensure that upon power-up, the limit window is set to maximum, and the $\overline{\text{ALERT}}$ pin does not become active until the desired limit values are programmed in the registers. Other default values for the temperature limits are available by request. The format of the data for T_{HIGH} and T_{LOW} is the same as for the temperature register.

Table 11. Bytes 1 and 2 of T_{HIGH} Register

BYTE	D7	D6	D5	D4	D3	D2	D1	D0
1	H11	H10	H9	H8	H7	H6	H5	H4
BYTE	D7	D6	D5	D4	D3	D2	D1	D0
2	H3	H2	H1	H0	0	0	0	0

Table 12. Bytes 1 and 2 of T_{LOW} Register

BYTE	D7	D6	D5	D4	D3	D2	D1	D0
1	L11	L10	L9	L8	L7	L6	L5	L4
BYTE	D7	D6	D5	D4	D3	D2	D1	D0
2	L3	L2	L1	L0	0	0	0	0

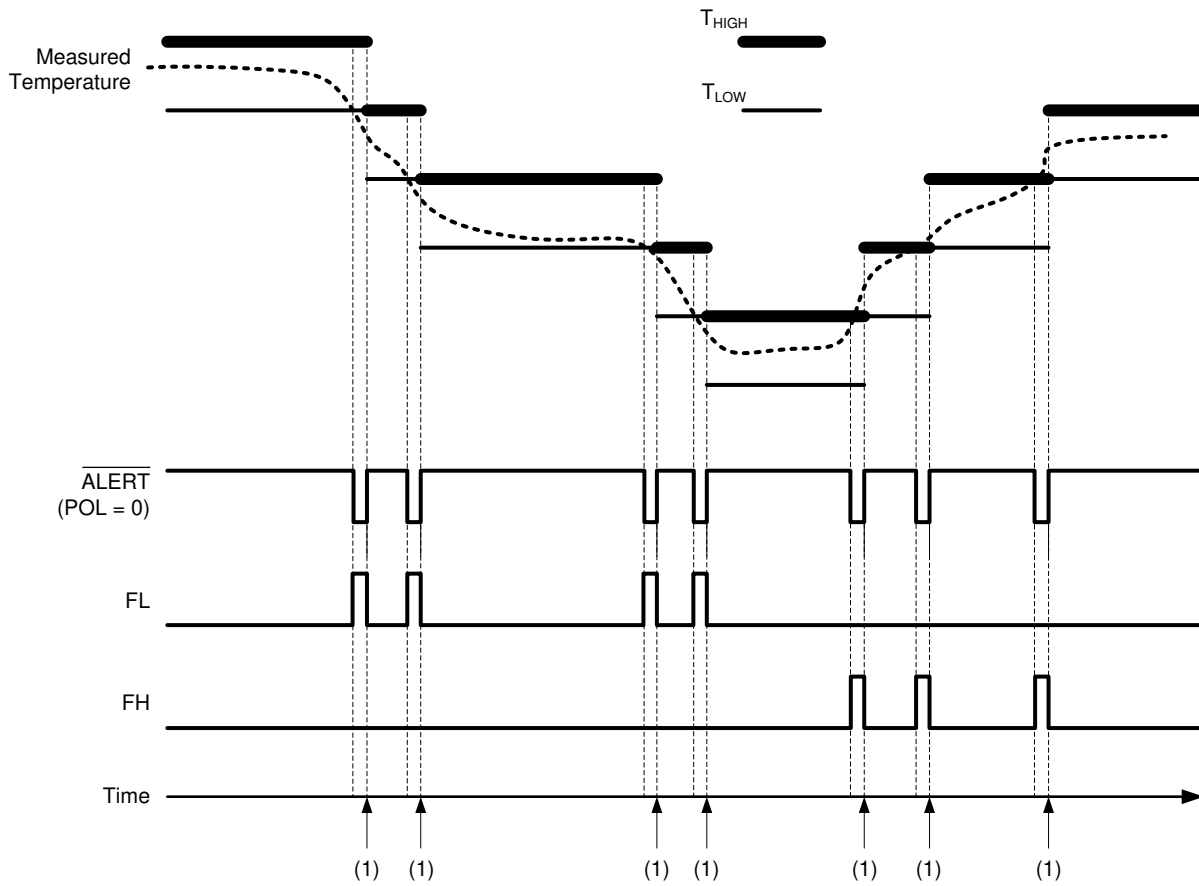

(1) Update T_{HIGH} and T_{LOW} limit. Read the configuration register to clear the flags and the $\overline{\text{ALERT}}$ pin.

Figure 13. Interrupt Mode

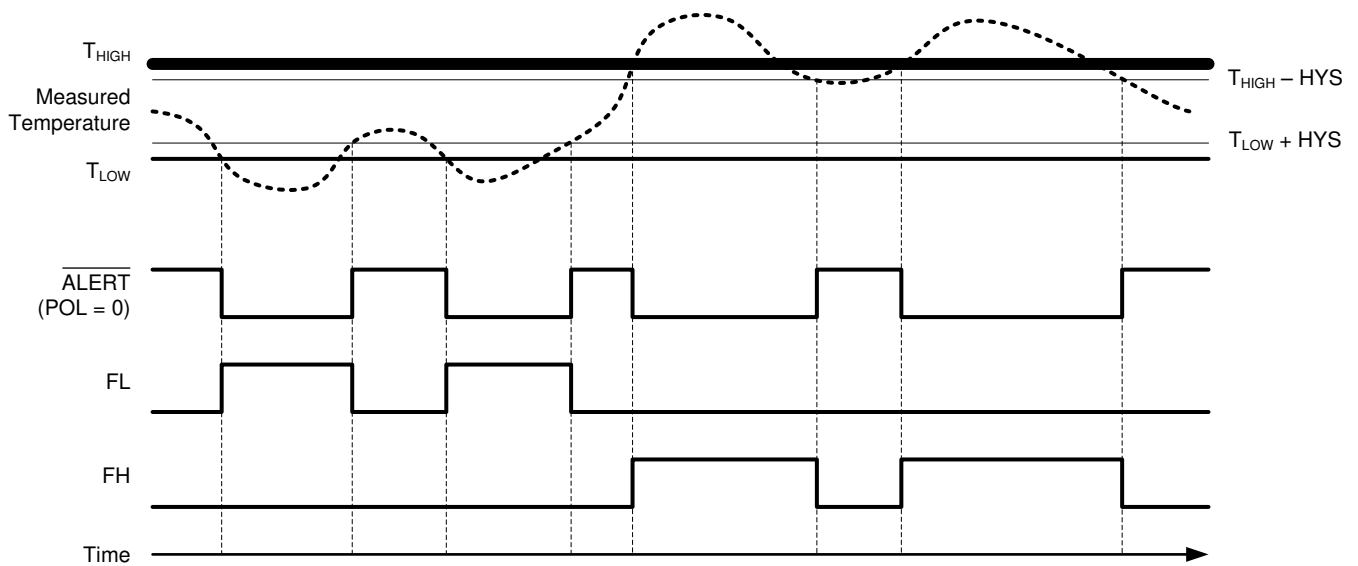

Figure 14. Comparator Mode

8 Application and Implementation

NOTE

Information in the following applications sections is not part of the TI component specification, and TI does not warrant its accuracy or completeness. TI's customers are responsible for determining suitability of components for their purposes. Customers should validate and test their design implementation to confirm system functionality.

8.1 Application Information

The TMP108 is used to measure the temperature of the board location where the device is mounted. The programmable address options allow up to four locations on the board to be monitored with a single serial bus.

8.2 Typical Application

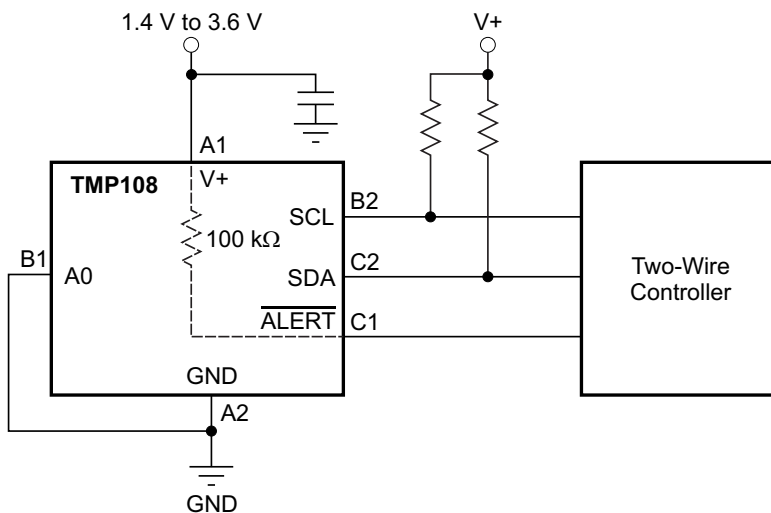

Figure 15. Typical Application Circuit

8.2.1 Design Requirements

The TMP108 only requires pullup resistors on SCL and SDA, but TI also recommends to use a 0.01- μ F bypass capacitor as shown in Figure 15. There is an internal 100-k Ω pullup resistor connected to supply on the ALERT pin. If required, use an external resistor of smaller value on the ALERT pin for a stronger pullup to V+. The SCL and SDA lines can be pulled up to a supply that is equal to or higher than V+ through the pullup resistors. To configure one of four different addresses on the bus, connect A0 to either V+, GND, SCL, or SDA. If A0 is connected to SCL or SDA, make their pullup supply equal to V+.

8.2.2 Detailed Design Procedure

The TMP108 devices must be placed in close proximity to the heat source that must be monitored, with a proper layout for good thermal coupling. This placement ensures that temperature changes are captured within the shortest possible time interval. To maintain accuracy in applications that require air or surface temperature measurement, take care to isolate the package and leads from PCB heat sources.

Typical Application (continued)

8.2.3 Application Curves

Figure 16 shows the step response of the TMP108 device to a submersion in an oil bath of 100°C from room temperature (25°C.) The time constant, or the time for the output to reach 63% of the input step, is about 1 second. Figure 17 shows the step response of the TMP108 device to an insertion in an air chamber of 100°C from room temperature (25°C.) The time-constant is 68 seconds. The time-constant result depends on the printed-circuit board (PCB) that the TMP108 device is mounted. For this test, the PCB is 0.5 in x 0.5 in, and the PCB thickness is 32 mils.

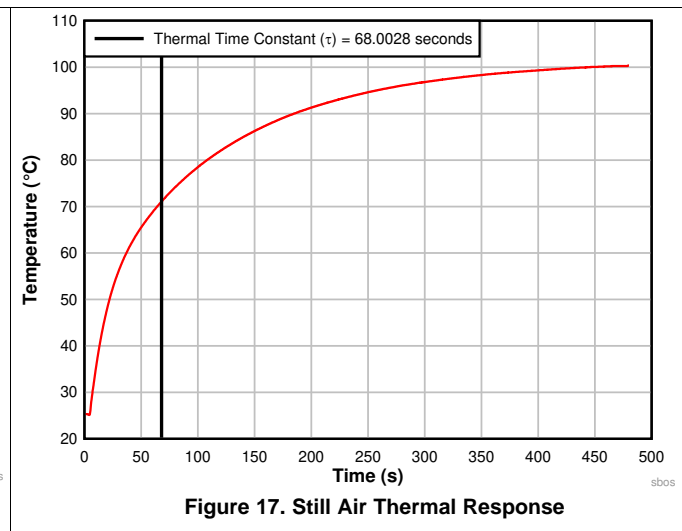
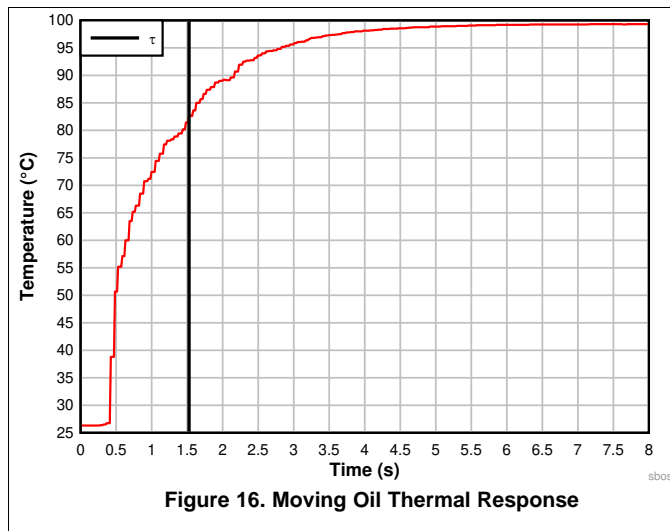

9 Power Supply Recommendations

The TMP108 operates on a power supply range from 1.4 V to 3.6 V. A power-supply bypass capacitor is required, which must be placed as close to the supply and ground pins of the device as possible. A typical supply bypass capacitor is 100 nF.

10 Layout

10.1 Layout Guidelines

Place the power-supply bypass capacitor as close as possible to the supply and ground pins. The recommended value of this bypass capacitor is 0.01 μF . Additional decoupling capacitance can be added to compensate for noisy or high-impedance power supplies. Pull up the open-drain output pins (SDA, SCL and ALERT) through 5-k Ω pullup resistors.

10.2 Layout Example

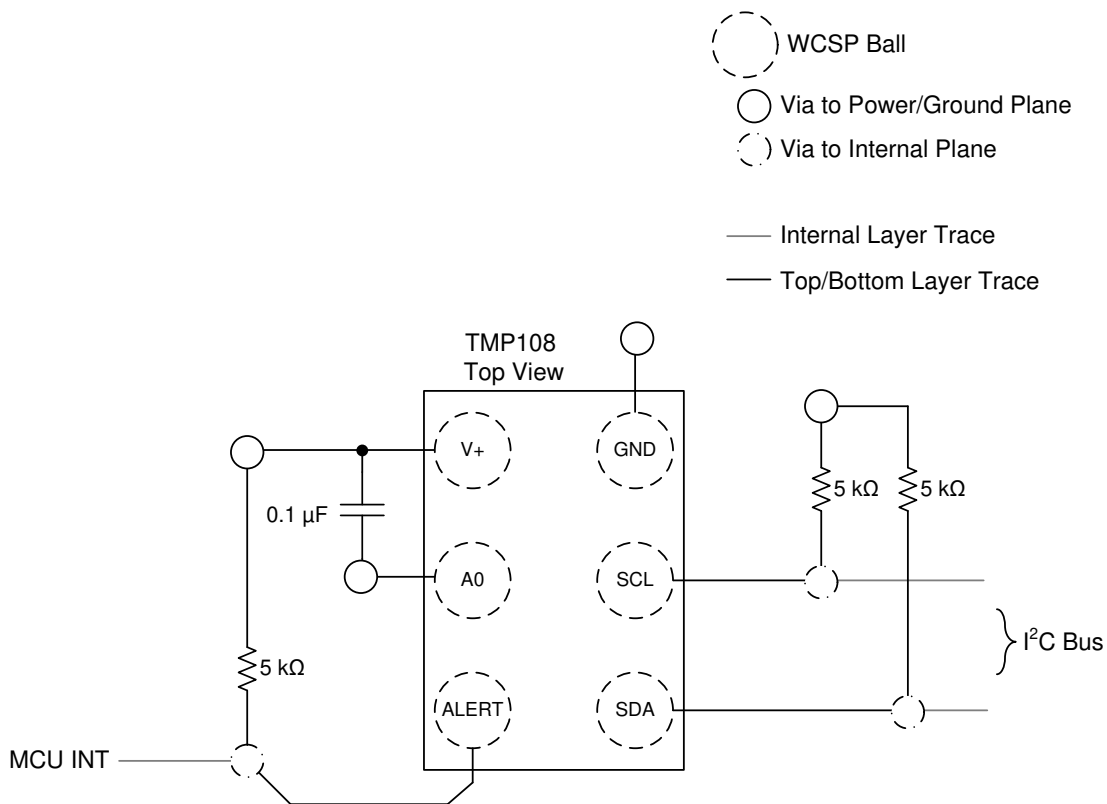

11 器件和文档支持

11.1 接收文档更新通知

要接收文档更新通知，请导航至 ti.com 上的器件产品文件夹。单击右上角的通知我进行注册，即可每周接收产品信息更改摘要。有关更改的详细信息，请查看任何已修订文档中包含的修订历史记录。

11.2 支持资源

TI E2E™ support forums are an engineer's go-to source for fast, verified answers and design help — straight from the experts. Search existing answers or ask your own question to get the quick design help you need.

Linked content is provided "AS IS" by the respective contributors. They do not constitute TI specifications and do not necessarily reflect TI's views; see TI's [Terms of Use](#).

11.3 商标

E2E is a trademark of Texas Instruments.

All other trademarks are the property of their respective owners.

11.4 静电放电警告



ESD 可能会损坏该集成电路。德州仪器 (TI) 建议通过适当的预防措施处理所有集成电路。如果不遵守正确的处理措施和安装程序，可能会损坏集成电路。

ESD 的损坏小至导致微小的性能降级，大至整个器件故障。精密的集成电路可能更容易受到损坏，这是因为非常细微的参数更改都可能会导致器件与其发布的规格不相符。

11.5 Glossary

[SLYZ022](#) — *TI Glossary*.

This glossary lists and explains terms, acronyms, and definitions.

12 机械、封装和可订购信息

以下页面包含机械、封装和可订购信息。这些信息是指定器件的最新可用数据。数据如有变更，恕不另行通知，且不会对此文档进行修订。如需获取此数据表的浏览器版本，请查阅左侧的导航栏。

PACKAGING INFORMATION

Orderable Device	Status (1)	Package Type	Package Drawing	Pins	Package Qty	Eco Plan (2)	Lead finish/ Ball material (6)	MSL Peak Temp (3)	Op Temp (°C)	Device Marking (4/5)	Samples
TMP108AIYFFR	ACTIVE	DSBGA	YFF	6	3000	RoHS & Green	SNAGCU	Level-1-260C-UNLIM	-40 to 125	T8	Samples
TMP108AIYFFT	OBSOLETE	DSBGA	YFF	6		TBD	Call TI	Call TI	-40 to 125	T8	

(1) The marketing status values are defined as follows:

ACTIVE: Product device recommended for new designs.

LIFEBUY: TI has announced that the device will be discontinued, and a lifetime-buy period is in effect.

NRND: Not recommended for new designs. Device is in production to support existing customers, but TI does not recommend using this part in a new design.

PREVIEW: Device has been announced but is not in production. Samples may or may not be available.

OBSOLETE: TI has discontinued the production of the device.

(2) **RoHS:** TI defines "RoHS" to mean semiconductor products that are compliant with the current EU RoHS requirements for all 10 RoHS substances, including the requirement that RoHS substance do not exceed 0.1% by weight in homogeneous materials. Where designed to be soldered at high temperatures, "RoHS" products are suitable for use in specified lead-free processes. TI may reference these types of products as "Pb-Free".

RoHS Exempt: TI defines "RoHS Exempt" to mean products that contain lead but are compliant with EU RoHS pursuant to a specific EU RoHS exemption.

Green: TI defines "Green" to mean the content of Chlorine (Cl) and Bromine (Br) based flame retardants meet JS709B low halogen requirements of <=1000ppm threshold. Antimony trioxide based flame retardants must also meet the <=1000ppm threshold requirement.

(3) MSL, Peak Temp. - The Moisture Sensitivity Level rating according to the JEDEC industry standard classifications, and peak solder temperature.

(4) There may be additional marking, which relates to the logo, the lot trace code information, or the environmental category on the device.

(5) Multiple Device Markings will be inside parentheses. Only one Device Marking contained in parentheses and separated by a "~" will appear on a device. If a line is indented then it is a continuation of the previous line and the two combined represent the entire Device Marking for that device.

(6) Lead finish/Ball material - Orderable Devices may have multiple material finish options. Finish options are separated by a vertical ruled line. Lead finish/Ball material values may wrap to two lines if the finish value exceeds the maximum column width.

Important Information and Disclaimer:The information provided on this page represents TI's knowledge and belief as of the date that it is provided. TI bases its knowledge and belief on information provided by third parties, and makes no representation or warranty as to the accuracy of such information. Efforts are underway to better integrate information from third parties. TI has taken and continues to take reasonable steps to provide representative and accurate information but may not have conducted destructive testing or chemical analysis on incoming materials and chemicals. TI and TI suppliers consider certain information to be proprietary, and thus CAS numbers and other limited information may not be available for release.

In no event shall TI's liability arising out of such information exceed the total purchase price of the TI part(s) at issue in this document sold by TI to Customer on an annual basis.

TAPE AND REEL INFORMATION

QUADRANT ASSIGNMENTS FOR PIN 1 ORIENTATION IN TAPE

*All dimensions are nominal

Device	Package Type	Package Drawing	Pins	SPQ	Reel Diameter (mm)	Reel Width W1 (mm)	A0 (mm)	B0 (mm)	K0 (mm)	P1 (mm)	W (mm)	Pin1 Quadrant
TMP108AIYFFR	DSBGA	YFF	6	3000	180.0	8.4	0.89	1.29	0.69	4.0	8.0	Q1
TMP108AIYFFR	DSBGA	YFF	6	3000	178.0	8.4	0.91	1.31	0.71	4.0	8.0	Q1

TAPE AND REEL BOX DIMENSIONS

*All dimensions are nominal

Device	Package Type	Package Drawing	Pins	SPQ	Length (mm)	Width (mm)	Height (mm)
TMP108AIYFFR	DSBGA	YFF	6	3000	182.0	182.0	20.0
TMP108AIYFFR	DSBGA	YFF	6	3000	220.0	220.0	35.0

EXAMPLE BOARD LAYOUT

YFF0006

DSBGA - 0.625 mm max height

DIE SIZE BALL GRID ARRAY

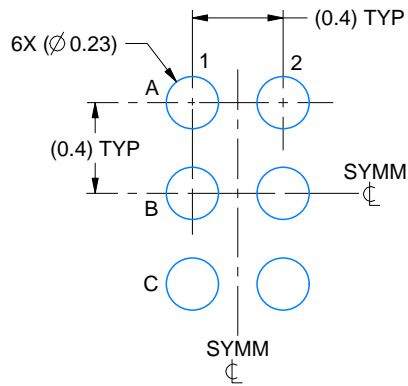

LAND PATTERN EXAMPLE
EXPOSED METAL SHOWN
SCALE:30X

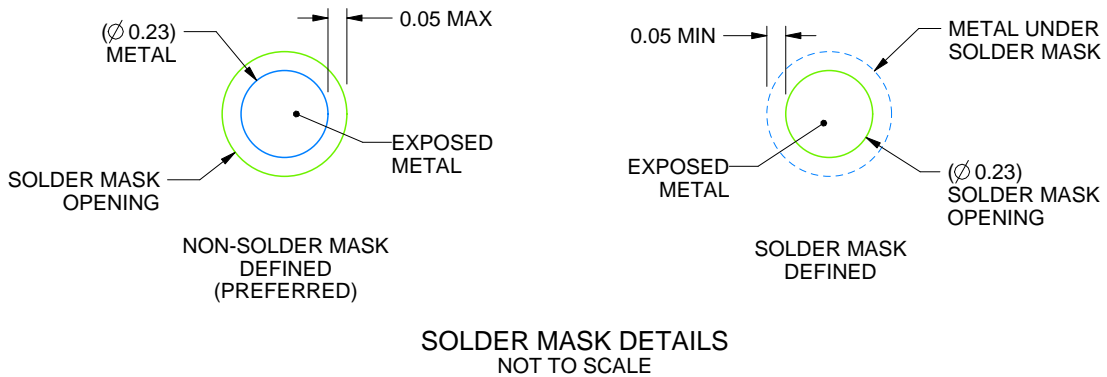

SOLDER MASK DETAILS
NOT TO SCALE

4223785/A 06/2017

NOTES: (continued)

- Final dimensions may vary due to manufacturing tolerance considerations and also routing constraints. For more information, see Texas Instruments literature number SNVA009 (www.ti.com/lit/snva009).

EXAMPLE STENCIL DESIGN

YFF0006

DSBGA - 0.625 mm max height

DIE SIZE BALL GRID ARRAY

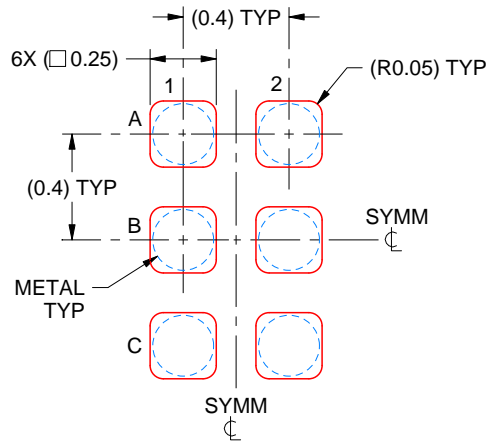

SOLDER PASTE EXAMPLE
BASED ON 0.1 mm THICK STENCIL
SCALE:35X

4223785/A 06/2017

NOTES: (continued)

4. Laser cutting apertures with trapezoidal walls and rounded corners may offer better paste release.

重要声明和免责声明

TI“按原样”提供技术和可靠性数据（包括数据表）、设计资源（包括参考设计）、应用或其他设计建议、网络工具、安全信息和其他资源，不保证没有瑕疵且不做任何明示或暗示的担保，包括但不限于对适销性、某特定用途方面的适用性或不侵犯任何第三方知识产权的暗示担保。

这些资源可供使用 TI 产品进行设计的熟练开发人员使用。您将自行承担以下全部责任：(1) 针对您的应用选择合适的 TI 产品，(2) 设计、验证并测试您的应用，(3) 确保您的应用满足相应标准以及任何其他功能安全、信息安全、监管或其他要求。

这些资源如有变更，恕不另行通知。TI 授权您仅可将这些资源用于研发本资源所述的 TI 产品的应用。严禁对这些资源进行其他复制或展示。您无权使用任何其他 TI 知识产权或任何第三方知识产权。您应全额赔偿因在这些资源的使用中对 TI 及其代表造成的任何索赔、损害、成本、损失和债务，TI 对此概不负责。

TI 提供的产品受 [TI 的销售条款](#) 或 [ti.com](#) 上其他适用条款/TI 产品随附的其他适用条款的约束。TI 提供这些资源并不会扩展或以其他方式更改 TI 针对 TI 产品发布的适用的担保或担保免责声明。

TI 反对并拒绝您可能提出的任何其他或不同的条款。

邮寄地址：Texas Instruments, Post Office Box 655303, Dallas, Texas 75265

Copyright © 2024，德州仪器 (TI) 公司