

TMUX720x 具有闩锁效应抑制和 1.8V 逻辑电平的 44V、低 RON、1:1 (SPST)、单通道精密开关

1 特性

- 闩锁效应抑制
- 双电源电压范围：±4.5 V 至 ±22 V
- 单电源电压范围：4.5 V 至 44 V
- 低导通电阻：1.2 Ω
- 低电荷注入：-10 pC
- -40°C 至 +125°C 工作温度
- 逻辑引脚上带有集成下拉电阻器
- 兼容 1.8V 逻辑电平
- 失效防护逻辑
- 轨到轨运行
- 双向信号路径
- 先断后合开关

2 应用

- 光纤网络
- 光学测试设备
- 有线网络
- 工厂自动化和工业控制
- 可编程逻辑控制器 (PLC)
- 半导体测试
- 超声波扫描仪
- 患者监护和诊断
- 远程无线电单元
- 数据采集系统

3 说明

TMUX720x 是一款具有闩锁效应抑制特性的互补金属氧化物半导体 (CMOS) 开关，采用单通道 1:1 (SPST) 配置。此器件在单电源 (4.5 V 至 44 V)、双电源 (±4.5 V 至 ±22 V) 或非对称电源 (例如 $V_{DD} = 12\text{ V}$, $V_{SS} = -5\text{ V}$) 供电时均能正常运行。TMUX720x 可在源极 (S) 和漏极 (D) 引脚上支持从 V_{SS} 到 V_{DD} 的双向模拟和数字信号。

可以通过控制 SEL 引脚来启用或禁用 TMUX720x。当禁用时，两个信号路径开关都被关闭。所有逻辑控制输入均支持 1.8V 至 V_{DD} 的逻辑电平，当器件在有效电源电压范围内运行时，可与 TTL 和 CMOS 逻辑兼容。失效防护逻辑电路允许先在控制引脚上施加电压，然后在电源引脚上施加电压，从而保护器件免受潜在的损害。

TMUX72xx 系列具有闩锁效应抑制特性，可防止器件内寄生结构之间通常由过压事件引起的大电流不良事件。闩锁状态通常会一直持续到电源轨关闭为止，并可能导致器件故障。闩锁效应抑制特性使得 TMUX72xx 系列开关和多路复用器能够在恶劣的环境中使用。

封装信息⁽¹⁾

| 器件型号 | 封装 | 封装尺寸 (标称值) |
|----------|----------------|-----------------|
| TMUX7202 | DGK (VSSOP, 8) | 3.00mm × 3.00mm |
| TMUX7201 | RQX (WQFN, 8) | 3.00mm × 2.00mm |

(1) 如需了解所有可用封装，请参阅数据表末尾的封装选项附录。

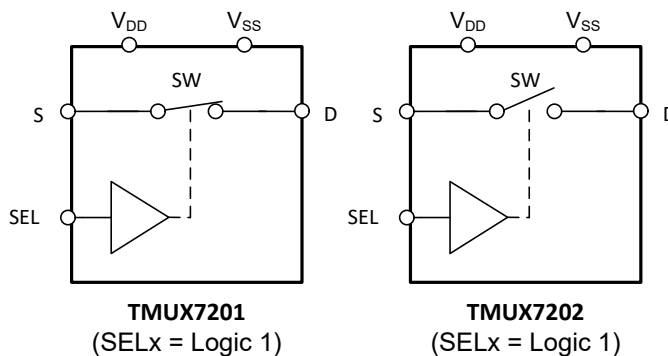

方框图



Table of Contents

| | | | |
|---|----|--|----|
| 1 特性 | 1 | 7.6 Propagation Delay..... | 21 |
| 2 应用 | 1 | 7.7 Charge Injection..... | 22 |
| 3 说明 | 1 | 7.8 Off Isolation..... | 22 |
| 4 Revision History | 2 | 7.9 Bandwidth..... | 23 |
| 5 Pin Configuration and Functions | 3 | 7.10 THD + Noise..... | 23 |
| 6 Specifications | 4 | 7.11 Power Supply Rejection Ratio (PSRR)..... | 24 |
| 6.1 Absolute Maximum Ratings..... | 4 | 8 Detailed Description | 24 |
| 6.2 ESD Ratings..... | 4 | 8.1 Overview..... | 24 |
| 6.3 Thermal Information..... | 5 | 8.2 Functional Block Diagram..... | 24 |
| 6.4 Recommended Operating Conditions..... | 5 | 8.3 Feature Description..... | 25 |
| 6.5 Source or Drain Continuous Current..... | 5 | 8.4 Device Functional Modes..... | 27 |
| 6.6 ±15 V Dual Supply: Electrical Characteristics | 6 | 8.5 Truth Tables..... | 27 |
| 6.7 ±15 V Dual Supply: Switching Characteristics | 7 | 9 Application and Implementation | 28 |
| 6.8 ±20 V Dual Supply: Electrical Characteristics..... | 8 | 9.1 Application Information..... | 28 |
| 6.9 ±20 V Dual Supply: Switching Characteristics..... | 9 | 9.2 Typical Applications..... | 28 |
| 6.10 44 V Single Supply: Electrical Characteristics | 10 | 9.3 Power Supply Recommendations..... | 30 |
| 6.11 44 V Single Supply: Switching Characteristics | 11 | 9.4 Layout..... | 30 |
| 6.12 12 V Single Supply: Electrical Characteristics | 12 | 10 Device and Documentation Support | 32 |
| 6.13 12 V Single Supply: Switching Characteristics | 13 | 10.1 Documentation Support..... | 32 |
| 6.14 Typical Characteristics..... | 14 | 10.2 接收文档更新通知..... | 32 |
| 7 Parameter Measurement Information | 19 | 10.3 支持资源..... | 32 |
| 7.1 On-Resistance..... | 19 | 10.4 Trademarks..... | 32 |
| 7.2 Off-Leakage Current..... | 19 | 10.5 静电放电警告..... | 32 |
| 7.3 On-Leakage Current..... | 20 | 10.6 术语表..... | 32 |
| 7.4 t_{ON} and t_{OFF} Time..... | 20 | 11 Mechanical, Packaging, and Orderable Information | 32 |
| 7.5 $t_{ON(VDD)}$ Time..... | 21 | | |

4 Revision History

注：以前版本的页码可能与当前版本的页码不同

Changes from Revision * (October 2022) to Revision A (March 2023)

| | Page |
|--|------|
| • 将数据表的状态从 <i>预告信息</i> 更改为 <i>量产数据</i> | 1 |

5 Pin Configuration and Functions



图 5-1. DGK Package, 8-Pin VSSOP (Top View)



图 5-2. RQX Package, 8-Pin WSON (Top View)

表 5-1. Pin Functions

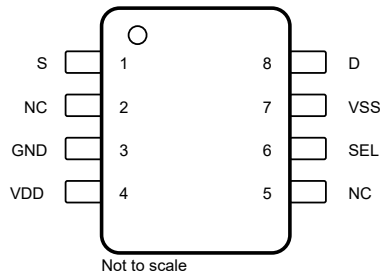
| NAME | PIN | | TYPE ⁽¹⁾ | DESCRIPTION ⁽²⁾ |
|-----------------|-----|-----|---------------------|---|
| | DGK | RQX | | |
| S | 1 | 1 | I/O | Source pin. Can be an input or output. |
| NC | 2 | 2 | NC | No connection. Not internally connected. |
| GND | 3 | 3 | P | Ground (0 V) reference |
| V _{DD} | 4 | 4 | P | Positive power supply. This pin is the most positive power-supply potential. For reliable operation, connect a decoupling capacitor ranging from 0.1 μ F to 10 μ F between V _{DD} and GND. |
| NC | 5 | 5 | NC | No connection. Not internally connected. |
| SEL | 6 | 6 | I | Logic control input, has internal Pull-Down resistor. For information about the switch connection controls, see 节 8.5. |
| V _{SS} | 7 | 7 | P | Negative power supply. This pin is the most negative power-supply potential. In single-supply applications, this pin can be connected to ground. For reliable operation, connect a decoupling capacitor ranging from 0.1 μ F to 10 μ F between V _{SS} and GND. |
| D | 8 | 8 | I/O | Drain pin. Can be an input or output. |
| Thermal Pad | | | — | The thermal pad is not connected internally. No requirement to solder this pad, if connected it is recommended that the pad be left floating or tied to GND |

(1) I = input, O = output, I/O = input or output, P = power, NC = no connection.

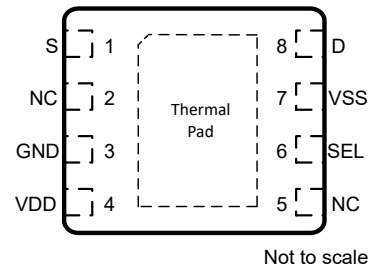
(2) For what to do with unused pins, refer to 节 8.4.

6 Specifications

6.1 Absolute Maximum Ratings

over operating free-air temperature range (unless otherwise noted)^{(1) (2)}

| | | MIN | MAX | UNIT |
|-----------------------|---|----------------|-----------------------|------|
| $V_{DD} - V_{SS}$ | Supply voltage | | 48 | V |
| V_{DD} | | - 0.5 | 48 | V |
| V_{SS} | | - 48 | 0.5 | V |
| V_{SEL} or V_{EN} | Logic control input pin voltage (SELx) | - 0.5 | 48 | V |
| I_{SEL} or I_{EN} | Logic control input pin current (SELx) | - 30 | 30 | mA |
| V_S or V_D | Source or drain voltage (Sx, Dx) | $V_{SS} - 0.5$ | $V_{DD} + 0.5$ | V |
| I_{IK} | Diode clamp current ⁽³⁾ | - 30 | 30 | mA |
| I_S or $I_D (CONT)$ | Source or drain continuous current (Sx, Dx) | | $I_{DC} + 10\%^{(4)}$ | mA |
| T_A | Ambient temperature | - 55 | 150 | °C |
| T_{stg} | Storage temperature | - 65 | 150 | °C |
| T_J | Junction temperature | | 150 | °C |

- (1) Operation outside the *Absolute Maximum Ratings* may cause permanent device damage. *Absolute Maximum Ratings* do not imply functional operation of the device at these or any other conditions beyond those listed under *Absolute Maximum Ratings*. If used outside the *Absolute Maximum Ratings* but within the *Absolute Maximum Ratings*, the device may not be fully functional, and this may affect device reliability, functionality, performance, and shorten the device lifetime.
- (2) All voltages are with respect to ground, unless otherwise specified.
- (3) Pins are diode-clamped to the power-supply rails. Over voltage signals must be voltage and current limited to maximum ratings.
- (4) Refer to *Source or Drain Continuous Current* table for I_{DC} specifications.

6.2 ESD Ratings

| | | VALUE | UNIT |
|-----------------|-------------------------|--|-------|
| TMUX720x | | | |
| $V_{(ESD)}$ | Electrostatic discharge | Human body model (HBM), per ANSI/ESDA/ JEDEC JS-001, all pins ⁽¹⁾ | ±2000 |
| | | Charged device model (CDM), per ANSI/ESDA/ JEDEC JS-002, all pins ⁽²⁾ | ±500 |

- (1) JEDEC document JEP155 states that 500-V HBM allows safe manufacturing with a standard ESD control process.
- (2) JEDEC document JEP157 states that 250-V CDM allows safe manufacturing with a standard ESD control process.

6.3 Thermal Information

| THERMAL METRIC ⁽¹⁾ | | TMUX720x | | UNIT |
|-------------------------------|--|-------------|------------|------|
| | | DGK (VSSOP) | RQX (WQFN) | |
| | | 8 PINS | 8 PINS | |
| $R_{\theta JA}$ | Junction-to-ambient thermal resistance | 152.1 | 62.9 | °C/W |
| $R_{\theta JC(top)}$ | Junction-to-case (top) thermal resistance | 48.4 | 54.0 | °C/W |
| $R_{\theta JB}$ | Junction-to-board thermal resistance | 73.2 | 31.0 | °C/W |
| Ψ_{JT} | Junction-to-top characterization parameter | 4.1 | 0.8 | °C/W |
| Ψ_{JB} | Junction-to-board characterization parameter | 71.8 | 30.9 | °C/W |
| $R_{\theta JC(bot)}$ | Junction-to-case (bottom) thermal resistance | N/A | 23.4 | °C/W |

(1) For more information about traditional and new thermal metrics, see the [Semiconductor and IC Package Thermal Metrics](#) application report.

6.4 Recommended Operating Conditions

over operating free-air temperature range (unless otherwise noted)

| | | MIN | NOM | MAX | UNIT |
|----------------------------------|--|----------|-----|-------------------------|------|
| $V_{DD} - V_{SS}$ ⁽¹⁾ | Power supply voltage differential | 4.5 | | 44 | V |
| V_{DD} | Positive power supply voltage | 4.5 | | 44 | V |
| V_S or V_D | Signal path input/output voltage (source or drain pin) (Sx, D) | V_{SS} | | V_{DD} | V |
| V_{SEL} or V_{EN} | Address or enable pin voltage | 0 | | 44 | V |
| I_S or $I_D (CONT)$ | Source or drain continuous current (Sx, D) | | | I_{DC} ⁽²⁾ | mA |
| T_A | Ambient temperature | - 40 | | 125 | °C |

(1) V_{DD} and V_{SS} can be any value as long as $4.5\text{ V} \leq (V_{DD} - V_{SS}) \leq 44\text{ V}$, and the minimum V_{DD} is met.

(2) Refer to *Source or Drain Continuous Current* table for I_{DC} specifications.

6.5 Source or Drain Continuous Current

at supply voltage of $V_{DD} \pm 10\%$, $V_{SS} \pm 10\%$ (unless otherwise noted)

| CONTINUOUS CURRENT PER CHANNEL (I_{DC}) ⁽²⁾ | | $T_A = 25^\circ\text{C}$ | $T_A = 85^\circ\text{C}$ | $T_A = 125^\circ\text{C}$ | UNIT |
|--|------------------------------------|--------------------------|--------------------------|---------------------------|------|
| PACKAGE | TEST CONDITIONS | | | | |
| DSK (VSSOP) | +44 V Dual Supply ⁽¹⁾ | 440 | 280 | 140 | mA |
| | ±15 V Dual Supply | 420 | 260 | 130 | mA |
| | +12 V Single Supply | 330 | 210 | 125 | mA |
| | ±5 V Dual Supply | 300 | 200 | 120 | mA |
| RQX (WQFN) | +44 V Single Supply ⁽¹⁾ | 650 | 350 | 165 | mA |
| | ±15 V Dual Supply | 600 | 340 | 150 | mA |
| | +12 V Single Supply | 500 | 300 | 145 | mA |
| | ±5 V Dual Supply | 450 | 265 | 135 | mA |

(1) Specified for nominal supply voltage only.

(2) Refer to Total power dissipation (P_{tot}) limits in *Absolute Maximum Ratings* table that must be followed with max continuous current specification.

6.6 ±15 V Dual Supply: Electrical Characteristics

$V_{DD} = +15\text{ V} \pm 10\%$, $V_{SS} = -15\text{ V} \pm 10\%$, GND = 0 V (unless otherwise noted)

Typical at $V_{DD} = +15\text{ V}$, $V_{SS} = -15\text{ V}$, $T_A = 25^\circ\text{C}$ (unless otherwise noted)

| PARAMETER | | TEST CONDITIONS | T_A | MIN | TYP | MAX | UNIT | |
|-------------------------------------|---|---|-----------------|-------|--------|------|-------------------------|----|
| ANALOG SWITCH | | | | | | | | |
| R_{ON} | On-resistance | $V_S = -10\text{ V to }+10\text{ V}$ $I_D = -10\text{ mA}$ | 25°C | 1.2 | 1.7 | | Ω | |
| | | | -40°C to +85°C | | | 2 | Ω | |
| | | | -40°C to +125°C | | | 2.5 | Ω | |
| $R_{ON\ FLAT}$ | On-resistance flatness | $V_S = -10\text{ V to }+10\text{ V}$ $I_D = -10\text{ mA}$ | 25°C | 0.3 | 0.5 | | Ω | |
| | | | -40°C to +85°C | | | 0.7 | Ω | |
| | | | -40°C to +125°C | | | 0.8 | Ω | |
| $R_{ON\ DRIFT}$ | On-resistance drift | $V_S = 0\text{ V}$, $I_S = -10\text{ mA}$ | -40°C to +125°C | 0.01 | | | $\Omega/^\circ\text{C}$ | |
| $I_{S(OFF)}$ | Source off leakage current ⁽¹⁾ | $V_{DD} = 16.5\text{ V}$, $V_{SS} = -16.5\text{ V}$ Switch state is off $V_S = +10\text{ V} / -10\text{ V}$ $V_D = -10\text{ V} / +10\text{ V}$ | 25°C | -0.3 | 0.05 | 0.3 | nA | |
| | | | -40°C to +85°C | | | -3.4 | 3.4 | nA |
| | | | -40°C to +125°C | | | -33 | 33 | nA |
| $I_{D(OFF)}$ | Drain off leakage current ⁽¹⁾ | $V_{DD} = 16.5\text{ V}$, $V_{SS} = -16.5\text{ V}$ Switch state is off $V_S = +10\text{ V} / -10\text{ V}$ $V_D = -10\text{ V} / +10\text{ V}$ | 25°C | -0.3 | 0.05 | 0.3 | nA | |
| | | | -40°C to +85°C | | | -3.4 | 3.4 | nA |
| | | | -40°C to +125°C | | | -33 | 33 | nA |
| $I_{S(ON)}$ $I_{D(ON)}$ | Channel on leakage current ⁽²⁾ | $V_{DD} = 16.5\text{ V}$, $V_{SS} = -16.5\text{ V}$ Switch state is on $V_S = V_D = \pm 10\text{ V}$ | 25°C | -0.65 | 0.05 | 0.65 | nA | |
| | | | -40°C to +85°C | | | -2 | 2 | nA |
| | | | -40°C to +125°C | | | -16 | 16 | nA |
| LOGIC INPUTS (SEL / EN pins) | | | | | | | | |
| V_{IH} | Logic voltage high | | -40°C to +125°C | 1.3 | | 44 | V | |
| V_{IL} | Logic voltage low | | -40°C to +125°C | 0 | | 0.8 | V | |
| I_{IH} | Input leakage current | | -40°C to +125°C | | 0.4 | 2 | μA | |
| I_{IL} | Input leakage current | | -40°C to +125°C | -0.1 | -0.005 | | μA | |
| C_{IN} | Logic input capacitance | | -40°C to +125°C | | 3.5 | | pF | |
| POWER SUPPLY | | | | | | | | |
| I_{DD} | V_{DD} supply current | $V_{DD} = 16.5\text{ V}$, $V_{SS} = -16.5\text{ V}$ Logic inputs = 0 V, 5 V, or V_{DD} | 25°C | 30 | 45 | | μA | |
| | | | -40°C to +85°C | | | 50 | μA | |
| | | | -40°C to +125°C | | | 55 | μA | |
| I_{SS} | V_{SS} supply current | $V_{DD} = 16.5\text{ V}$, $V_{SS} = -16.5\text{ V}$ Logic inputs = 0 V, 5 V, or V_{DD} | 25°C | 7 | 12 | | μA | |
| | | | -40°C to +85°C | | | 15 | μA | |
| | | | -40°C to +125°C | | | 17 | μA | |

(1) When V_S is positive, V_D is negative, or when V_S is negative, V_D is positive.

(2) When V_S is at a voltage potential, V_D is floating, or when V_D is at a voltage potential, V_S is floating.

6.7 ±15 V Dual Supply: Switching Characteristics

 $V_{DD} = +15\text{ V} \pm 10\%$, $V_{SS} = -15\text{ V} \pm 10\%$, $GND = 0\text{ V}$ (unless otherwise noted)

 Typical at $V_{DD} = +15\text{ V}$, $V_{SS} = -15\text{ V}$, $T_A = 25^\circ\text{C}$ (unless otherwise noted)

| PARAMETER | | TEST CONDITIONS | T_A | MIN | TYP | MAX | UNIT |
|------------------------------|---|--|-----------------|-----|--------|-----|------|
| t_{ON} | Turn-on time from control input | $V_S = 10\text{ V}$ $R_L = 300\ \Omega$, $C_L = 35\text{ pF}$ | 25°C | | 120 | 140 | ns |
| | | | -40°C to +85°C | | | 155 | ns |
| | | | -40°C to +125°C | | | 170 | ns |
| t_{OFF} | Turn-off time from control input | $V_S = 10\text{ V}$ $R_L = 300\ \Omega$, $C_L = 35\text{ pF}$ | 25°C | | 130 | 150 | ns |
| | | | -40°C to +85°C | | | 160 | ns |
| | | | -40°C to +125°C | | | 190 | ns |
| $t_{ON(VDD)}$ | Device turn on time (V_{DD} to output) | V_{DD} rise time = 1 μs $R_L = 300\ \Omega$, $C_L = 35\text{ pF}$ | -40°C to +125°C | | 0.2 | | ms |
| t_{PD} | Propagation delay | $R_L = 50\ \Omega$, $C_L = 5\text{ pF}$ | 25°C | | 450 | | ps |
| Q_{INJ} | Charge injection | $V_S = 0\text{ V}$, $C_L = 100\text{ pF}$ | 25°C | | -15 | | pC |
| O_{ISO} | Off-isolation | $R_L = 50\ \Omega$, $C_L = 5\text{ pF}$ $V_S = 0\text{ V}$, $f = 100\text{ kHz}$ | 25°C | | -70 | | dB |
| O_{ISO} | Off-isolation | $R_L = 50\ \Omega$, $C_L = 5\text{ pF}$ $V_S = 0\text{ V}$, $f = 1\text{ MHz}$ | 25°C | | -46 | | dB |
| BW | -3 dB Bandwidth | $R_L = 50\ \Omega$, $C_L = 5\text{ pF}$ $V_S = 0\text{ V}$ | 25°C | | 22 | | MHz |
| I_L | Insertion loss | $R_L = 50\ \Omega$, $C_L = 5\text{ pF}$ $V_S = 0\text{ V}$, $f = 1\text{ MHz}$ | 25°C | | -0.11 | | dB |
| ACPSRR | AC Power Supply Rejection Ratio | $V_{PP} = 0.62\text{ V}$ on V_{DD} and V_{SS} $R_L = 50\ \Omega$, $C_L = 5\text{ pF}$, $f = 1\text{ MHz}$ | 25°C | | -40 | | dB |
| THD+N | Total Harmonic Distortion + Noise | $V_{PP} = 15\text{ V}$, $V_{BIAS} = 0\text{ V}$ $R_L = 10\text{ k}\Omega$, $C_L = 5\text{ pF}$, $f = 20\text{ Hz}$ to 20 kHz | 25°C | | 0.0007 | | % |
| $C_{S(OFF)}$ | Source off capacitance | $V_S = 0\text{ V}$, $f = 1\text{ MHz}$ | 25°C | | 45 | | pF |
| $C_{D(OFF)}$ | Drain off capacitance | $V_S = 0\text{ V}$, $f = 1\text{ MHz}$ | 25°C | | 65 | | pF |
| $C_{S(ON)}$, $C_{D(ON)}$ | On capacitance | $V_S = 0\text{ V}$, $f = 1\text{ MHz}$ | 25°C | | 240 | | pF |

6.8 ±20 V Dual Supply: Electrical Characteristics

$V_{DD} = +20\text{ V} \pm 10\%$, $V_{SS} = -20\text{ V} \pm 10\%$, GND = 0 V (unless otherwise noted)

Typical at $V_{DD} = +20\text{ V}$, $V_{SS} = -20\text{ V}$, $T_A = 25^\circ\text{C}$ (unless otherwise noted)

| PARAMETER | | TEST CONDITIONS | T_A | MIN | TYP | MAX | UNIT | |
|-------------------------------------|---|---|-----------------|------|--------|-----|-------------------------|----|
| ANALOG SWITCH | | | | | | | | |
| R_{ON} | On-resistance | $V_S = -15\text{ V to }+15\text{ V}$ $I_D = -10\text{ mA}$ | 25°C | | 1 | 1.5 | Ω | |
| | | | -40°C to +85°C | | | 1.8 | Ω | |
| | | | -40°C to +125°C | | | 2.3 | Ω | |
| $R_{ON\ FLAT}$ | On-resistance flatness | $V_S = -15\text{ V to }+15\text{ V}$ $I_S = -10\text{ mA}$ | 25°C | | 0.3 | 0.5 | Ω | |
| | | | -40°C to +85°C | | | 0.7 | Ω | |
| | | | -40°C to +125°C | | | 0.8 | Ω | |
| $R_{ON\ DRIFT}$ | On-resistance drift | $V_S = 0\text{ V}$, $I_S = -10\text{ mA}$ | -40°C to +125°C | | 0.009 | | $\Omega/^\circ\text{C}$ | |
| $I_{S(OFF)}$ | Source off leakage current ⁽¹⁾ | $V_{DD} = 22\text{ V}$, $V_{SS} = -22\text{ V}$ Switch state is off $V_S = +15\text{ V} / -15\text{ V}$ $V_D = -15\text{ V} / +15\text{ V}$ | 25°C | -0.4 | 0.05 | 0.4 | nA | |
| | | | -40°C to +85°C | | -5 | | 5 | nA |
| | | | -40°C to +125°C | | -35 | | 35 | nA |
| $I_{D(OFF)}$ | Drain off leakage current ⁽¹⁾ | $V_{DD} = 22\text{ V}$, $V_{SS} = -22\text{ V}$ Switch state is off $V_S = +15\text{ V} / -15\text{ V}$ $V_D = -15\text{ V} / +15\text{ V}$ | 25°C | -0.4 | 0.05 | 0.4 | nA | |
| | | | -40°C to +85°C | | -5 | | 5 | nA |
| | | | -40°C to +125°C | | -35 | | 35 | nA |
| $I_{S(ON)}$ $I_{D(ON)}$ | Channel on leakage current ⁽²⁾ | $V_{DD} = 22\text{ V}$, $V_{SS} = -22\text{ V}$ Switch state is on $V_S = V_D = \pm 15\text{ V}$ | 25°C | -0.7 | 0.05 | 0.7 | nA | |
| | | | -40°C to +85°C | | -2 | | 2 | nA |
| | | | -40°C to +125°C | | -18 | | 18 | nA |
| LOGIC INPUTS (SEL / EN pins) | | | | | | | | |
| V_{IH} | Logic voltage high | | -40°C to +125°C | 1.3 | | 44 | V | |
| V_{IL} | Logic voltage low | | -40°C to +125°C | 0 | | 0.8 | V | |
| I_{IH} | Input leakage current | | -40°C to +125°C | | 0.4 | 2 | μA | |
| I_{IL} | Input leakage current | | -40°C to +125°C | -0.1 | -0.005 | | μA | |
| C_{IN} | Logic input capacitance | | -40°C to +125°C | | 3.5 | | pF | |
| POWER SUPPLY | | | | | | | | |
| I_{DD} | V_{DD} supply current | $V_{DD} = 22\text{ V}$, $V_{SS} = -22\text{ V}$ Logic inputs = 0 V, 5 V, or V_{DD} | 25°C | | 38 | 50 | μA | |
| | | | -40°C to +85°C | | | 60 | μA | |
| | | | -40°C to +125°C | | | 70 | μA | |
| I_{SS} | V_{SS} supply current | $V_{DD} = 22\text{ V}$, $V_{SS} = -22\text{ V}$ Logic inputs = 0 V, 5 V, or V_{DD} | 25°C | | 8 | 15 | μA | |
| | | | -40°C to +85°C | | | 19 | μA | |
| | | | -40°C to +125°C | | | 23 | μA | |

(1) When V_S is positive, V_D is negative, or when V_S is negative, V_D is positive.

(2) When V_S is at a voltage potential, V_D is floating, or when V_D is at a voltage potential, V_S is floating.

6.9 ±20 V Dual Supply: Switching Characteristics

$V_{DD} = +20\text{ V} \pm 10\%$, $V_{SS} = -20\text{ V} \pm 10\%$, $GND = 0\text{ V}$ (unless otherwise noted)

Typical at $V_{DD} = +20\text{ V}$, $V_{SS} = -20\text{ V}$, $T_A = 25^\circ\text{C}$ (unless otherwise noted)

| PARAMETER | | TEST CONDITIONS | T_A | MIN | TYP | MAX | UNIT |
|------------------------------|---|--|-----------------|-----|--------|-----|------|
| t_{ON} | Turn-on time from control input | $V_S = 10\text{ V}$ $R_L = 300\ \Omega$, $C_L = 35\text{ pF}$ | 25°C | | 120 | 140 | ns |
| | | | -40°C to +85°C | | | 155 | ns |
| | | | -40°C to +125°C | | | 190 | ns |
| t_{OFF} | Turn-off time from control input | $V_S = 10\text{ V}$ $R_L = 300\ \Omega$, $C_L = 35\text{ pF}$ | 25°C | | 120 | 150 | ns |
| | | | -40°C to +85°C | | | 160 | ns |
| | | | -40°C to +125°C | | | 190 | ns |
| $t_{ON(VDD)}$ | Device turn on time (V_{DD} to output) | V_{DD} rise time = 1 μs $R_L = 300\ \Omega$, $C_L = 35\text{ pF}$ | -40°C to +125°C | | 0.2 | | ms |
| t_{PD} | Propagation delay | $R_L = 50\ \Omega$, $C_L = 5\text{ pF}$ | 25°C | | 400 | | ps |
| Q_{INJ} | Charge injection | $V_S = 0\text{ V}$, $C_L = 100\text{ pF}$ | 25°C | | -20 | | pC |
| O_{ISO} | Off-isolation | $R_L = 50\ \Omega$, $C_L = 5\text{ pF}$ $V_S = 0\text{ V}$, $f = 100\text{ kHz}$ | 25°C | | -65 | | dB |
| O_{ISO} | Off-isolation | $R_L = 50\ \Omega$, $C_L = 5\text{ pF}$ $V_S = 0\text{ V}$, $f = 1\text{ MHz}$ | 25°C | | -45 | | dB |
| BW | -3 dB Bandwidth | $R_L = 50\ \Omega$, $C_L = 5\text{ pF}$ $V_S = 0\text{ V}$ | 25°C | | 22 | | MHz |
| I_L | Insertion loss | $R_L = 50\ \Omega$, $C_L = 5\text{ pF}$ $V_S = 0\text{ V}$, $f = 1\text{ MHz}$ | 25°C | | -0.10 | | dB |
| ACPSRR | AC Power Supply Rejection Ratio | $V_{PP} = 0.62\text{ V}$ on V_{DD} and V_{SS} $R_L = 50\ \Omega$, $C_L = 5\text{ pF}$, $f = 1\text{ MHz}$ | 25°C | | -40 | | dB |
| THD+N | Total Harmonic Distortion + Noise | $V_{PP} = 20\text{ V}$, $V_{BIAS} = 0\text{ V}$ $R_L = 10\text{ k}\Omega$, $C_L = 5\text{ pF}$, $f = 20\text{ Hz}$ to 20 kHz | 25°C | | 0.0008 | | % |
| $C_{S(OFF)}$ | Source off capacitance | $V_S = 0\text{ V}$, $f = 1\text{ MHz}$ | 25°C | | 42 | | pF |
| $C_{D(OFF)}$ | Drain off capacitance | $V_S = 0\text{ V}$, $f = 1\text{ MHz}$ | 25°C | | 62 | | pF |
| $C_{S(ON)}$, $C_{D(ON)}$ | On capacitance | $V_S = 0\text{ V}$, $f = 1\text{ MHz}$ | 25°C | | 240 | | pF |

6.10 44 V Single Supply: Electrical Characteristics

$V_{DD} = +44\text{ V}$, $V_{SS} = 0\text{ V}$, $GND = 0\text{ V}$ (unless otherwise noted)

Typical at $V_{DD} = +44\text{ V}$, $V_{SS} = 0\text{ V}$, $T_A = 25^\circ\text{C}$ (unless otherwise noted)

| PARAMETER | | TEST CONDITIONS | T_A | MIN | TYP | MAX | UNIT | |
|-------------------------------------|---|---|-----------------|-------|--------|-----|-------------------------|----|
| ANALOG SWITCH | | | | | | | | |
| R_{ON} | On-resistance | $V_S = 0\text{ V to }40\text{ V}$ $I_D = -10\text{ mA}$ | 25°C | 1.2 | | 1.6 | Ω | |
| | | | -40°C to +85°C | | | 2 | Ω | |
| | | | -40°C to +125°C | | | 2.4 | Ω | |
| $R_{ON\ FLAT}$ | On-resistance flatness | $V_S = 0\text{ V to }40\text{ V}$ $I_D = -10\text{ mA}$ | 25°C | 0.25 | | 0.9 | Ω | |
| | | | -40°C to +85°C | | | 1.1 | Ω | |
| | | | -40°C to +125°C | | | 1.3 | Ω | |
| $R_{ON\ DRIFT}$ | On-resistance drift | $V_S = 22\text{ V}$, $I_S = -10\text{ mA}$ | -40°C to +125°C | 0.008 | | | $\Omega/^\circ\text{C}$ | |
| $I_{S(OFF)}$ | Source off leakage current ⁽¹⁾ | $V_{DD} = 44\text{ V}$, $V_{SS} = 0\text{ V}$ Switch state is off $V_S = 40\text{ V} / 1\text{ V}$ $V_D = 1\text{ V} / 40\text{ V}$ | 25°C | -1 | 0.05 | 1 | nA | |
| | | | -40°C to +85°C | | | -10 | 10 | nA |
| | | | -40°C to +125°C | | | -60 | 60 | nA |
| $I_{D(OFF)}$ | Drain off leakage current ⁽¹⁾ | $V_{DD} = 44\text{ V}$, $V_{SS} = 0\text{ V}$ Switch state is off $V_S = 40\text{ V} / 1\text{ V}$ $V_D = 1\text{ V} / 40\text{ V}$ | 25°C | -1 | 0.05 | 1 | nA | |
| | | | -40°C to +85°C | | | -10 | 10 | nA |
| | | | -40°C to +125°C | | | -60 | 60 | nA |
| $I_{S(ON)}$ $I_{D(ON)}$ | Channel on leakage current ⁽²⁾ | $V_{DD} = 44\text{ V}$, $V_{SS} = 0\text{ V}$ Switch state is on $V_S = V_D = 40\text{ V or }1\text{ V}$ | 25°C | -2 | 0.05 | 2 | nA | |
| | | | -40°C to +85°C | | | -5 | 5 | nA |
| | | | -40°C to +125°C | | | -30 | 30 | nA |
| LOGIC INPUTS (SEL / EN pins) | | | | | | | | |
| V_{IH} | Logic voltage high | | -40°C to +125°C | 1.3 | | 44 | V | |
| V_{IL} | Logic voltage low | | -40°C to +125°C | 0 | | 0.8 | V | |
| I_{IH} | Input leakage current | | -40°C to +125°C | | 0.6 | 2 | μA | |
| I_{IL} | Input leakage current | | -40°C to +125°C | -0.1 | -0.005 | | μA | |
| C_{IN} | Logic input capacitance | | -40°C to +125°C | | 3.5 | | pF | |
| POWER SUPPLY | | | | | | | | |
| I_{DD} | V_{DD} supply current | $V_{DD} = 44\text{ V}$, $V_{SS} = 0\text{ V}$ Logic inputs = 0 V, 5 V, or V_{DD} | 25°C | | 30 | 56 | μA | |
| | | | -40°C to +85°C | | | 64 | μA | |
| | | | -40°C to +125°C | | | 68 | μA | |

(1) When V_S is positive, V_D is negative, or when V_S is negative, V_D is positive.

(2) When V_S is at a voltage potential, V_D is floating, or when V_D is at a voltage potential, V_S is floating.

6.11 44 V Single Supply: Switching Characteristics

$V_{DD} = +44\text{ V}$, $V_{SS} = 0\text{ V}$, $GND = 0\text{ V}$ (unless otherwise noted)

Typical at $V_{DD} = +44\text{ V}$, $V_{SS} = 0\text{ V}$, $T_A = 25^\circ\text{C}$ (unless otherwise noted)

| PARAMETER | | TEST CONDITIONS | T_A | MIN | TYP | MAX | UNIT |
|------------------------------|---|---|-----------------|-----|--------|-----|------|
| t_{ON} | Turn-on time from control input | $V_S = 18\text{ V}$ $R_L = 300\ \Omega$, $C_L = 35\text{ pF}$ | 25°C | | 100 | 140 | ns |
| | | | -40°C to +85°C | | | 150 | ns |
| | | | -40°C to +125°C | | | 180 | ns |
| t_{OFF} | Turn-off time from control input | $V_S = 18\text{ V}$ $R_L = 300\ \Omega$, $C_L = 35\text{ pF}$ | 25°C | | 125 | 150 | ns |
| | | | -40°C to +85°C | | | 160 | ns |
| | | | -40°C to +125°C | | | 180 | ns |
| $t_{ON(VDD)}$ | Device turn on time (V_{DD} to output) | V_{DD} rise time = 1 μs $R_L = 300\ \Omega$, $C_L = 35\text{ pF}$ | -40°C to +125°C | | 0.17 | | ms |
| t_{PD} | Propagation delay | $R_L = 50\ \Omega$, $C_L = 5\text{ pF}$ | 25°C | | 1000 | | ps |
| Q_{INJ} | Charge injection | $V_S = 22\text{ V}$, $C_L = 100\text{ pF}$ | 25°C | | -20 | | pC |
| O_{ISO} | Off-isolation | $R_L = 50\ \Omega$, $C_L = 5\text{ pF}$ $V_S = 6\text{ V}$, $f = 100\text{ kHz}$ | 25°C | | -66 | | dB |
| O_{ISO} | Off-isolation | $R_L = 50\ \Omega$, $C_L = 5\text{ pF}$ $V_S = 6\text{ V}$, $f = 1\text{ MHz}$ | 25°C | | -46 | | dB |
| BW | -3 dB Bandwidth | $R_L = 50\ \Omega$, $C_L = 5\text{ pF}$ $V_S = 6\text{ V}$ | 25°C | | 22 | | MHz |
| I_L | Insertion loss | $R_L = 50\ \Omega$, $C_L = 5\text{ pF}$ $V_S = 6\text{ V}$, $f = 1\text{ MHz}$ | 25°C | | -0.11 | | dB |
| ACPSRR | AC Power Supply Rejection Ratio | $V_{PP} = 0.62\text{ V}$ on V_{DD} and V_{SS} $R_L = 50\ \Omega$, $C_L = 5\text{ pF}$, $f = 1\text{ MHz}$ | 25°C | | -36 | | dB |
| THD+N | Total Harmonic Distortion + Noise | $V_{PP} = 22\text{ V}$, $V_{BIAS} = 22\text{ V}$ $R_L = 10\text{ k}\Omega$, $C_L = 5\text{ pF}$, $f = 20\text{ Hz}$ to 20 kHz | 25°C | | 0.0008 | | % |
| $C_{S(OFF)}$ | Source off capacitance | $V_S = 22\text{ V}$, $f = 1\text{ MHz}$ | 25°C | | 45 | | pF |
| $C_{D(OFF)}$ | Drain off capacitance | $V_S = 22\text{ V}$, $f = 1\text{ MHz}$ | 25°C | | 66 | | pF |
| $C_{S(ON)}$, $C_{D(ON)}$ | On capacitance | $V_S = 22\text{ V}$, $f = 1\text{ MHz}$ | 25°C | | 240 | | pF |

6.12 12 V Single Supply: Electrical Characteristics

$V_{DD} = +12\text{ V} \pm 10\%$, $V_{SS} = 0\text{ V}$, $GND = 0\text{ V}$ (unless otherwise noted)

Typical at $V_{DD} = +12\text{ V}$, $V_{SS} = 0\text{ V}$, $T_A = 25^\circ\text{C}$ (unless otherwise noted)

| PARAMETER | | TEST CONDITIONS | T_A | MIN | TYP | MAX | UNIT | |
|-------------------------------------|---|---|-----------------|-------|--------|------|-------------------------|----|
| ANALOG SWITCH | | | | | | | | |
| R_{ON} | On-resistance | $V_S = 0\text{ V to }10\text{ V}$ $I_D = -10\text{ mA}$ | 25°C | | 2.1 | 3.2 | Ω | |
| | | | -40°C to +85°C | | | 3.8 | Ω | |
| | | | -40°C to +125°C | | | 4.2 | Ω | |
| $R_{ON\ FLAT}$ | On-resistance flatness | $V_S = 0\text{ V to }10\text{ V}$ $I_S = -10\text{ mA}$ | 25°C | | 0.5 | 1.2 | Ω | |
| | | | -40°C to +85°C | | | 1.4 | Ω | |
| | | | -40°C to +125°C | | | 1.6 | Ω | |
| $R_{ON\ DRIFT}$ | On-resistance drift | $V_S = 6\text{ V}$, $I_S = -10\text{ mA}$ | -40°C to +125°C | | 0.017 | | $\Omega/^\circ\text{C}$ | |
| $I_{S(OFF)}$ | Source off leakage current ⁽¹⁾ | $V_{DD} = 13.2\text{ V}$, $V_{SS} = 0\text{ V}$ Switch state is off $V_S = 10\text{ V} / 1\text{ V}$ $V_D = 1\text{ V} / 10\text{ V}$ | 25°C | -0.4 | 0.05 | 0.4 | nA | |
| | | | -40°C to +85°C | | -3 | | 3 | nA |
| | | | -40°C to +125°C | | -25 | | 25 | nA |
| $I_{D(OFF)}$ | Drain off leakage current ⁽¹⁾ | $V_{DD} = 13.2\text{ V}$, $V_{SS} = 0\text{ V}$ Switch state is off $V_S = 10\text{ V} / 1\text{ V}$ $V_D = 1\text{ V} / 10\text{ V}$ | 25°C | -0.4 | 0.05 | 0.4 | nA | |
| | | | -40°C to +85°C | | -3 | | 3 | nA |
| | | | -40°C to +125°C | | -25 | | 25 | nA |
| $I_{S(ON)}$ $I_{D(ON)}$ | Channel on leakage current ⁽²⁾ | $V_{DD} = 13.2\text{ V}$, $V_{SS} = 0\text{ V}$ Switch state is on $V_S = V_D = 10\text{ V or }1\text{ V}$ | 25°C | -0.65 | 0.05 | 0.65 | nA | |
| | | | -40°C to +85°C | | -2 | | 2 | nA |
| | | | -40°C to +125°C | | -12 | | 12 | nA |
| LOGIC INPUTS (SEL / EN pins) | | | | | | | | |
| V_{IH} | Logic voltage high | | -40°C to +125°C | 1.3 | | 44 | V | |
| V_{IL} | Logic voltage low | | -40°C to +125°C | 0 | | 0.8 | V | |
| I_{IH} | Input leakage current | | -40°C to +125°C | | 0.4 | 2 | μA | |
| I_{IL} | Input leakage current | | -40°C to +125°C | -0.1 | -0.005 | | μA | |
| C_{IN} | Logic input capacitance | | -40°C to +125°C | | 3.5 | | pF | |
| POWER SUPPLY | | | | | | | | |
| I_{DD} | V_{DD} supply current | $V_{DD} = 13.2\text{ V}$, $V_{SS} = 0\text{ V}$ Logic inputs = 0 V, 5 V, or V_{DD} | 25°C | | 27 | 35 | μA | |
| | | | -40°C to +85°C | | | 40 | μA | |
| | | | -40°C to +125°C | | | 45 | μA | |

(1) When V_S is positive, V_D is negative, or when V_S is negative, V_D is positive.

(2) When V_S is at a voltage potential, V_D is floating, or when V_D is at a voltage potential, V_S is floating.

6.13 12 V Single Supply: Switching Characteristics

$V_{DD} = +12\text{ V} \pm 10\%$, $V_{SS} = 0\text{ V}$, $GND = 0\text{ V}$ (unless otherwise noted)

Typical at $V_{DD} = +12\text{ V}$, $V_{SS} = 0\text{ V}$, $T_A = 25^\circ\text{C}$ (unless otherwise noted)

| PARAMETER | | TEST CONDITIONS | T_A | MIN | TYP | MAX | UNIT |
|------------------------------|---|---|-----------------|-----|--------|-----|------|
| t_{ON} | Turn-on time from control input | $V_S = 8\text{ V}$ $R_L = 300\ \Omega$, $C_L = 35\text{ pF}$ | 25°C | | 125 | 145 | ns |
| | | | -40°C to +85°C | | | 160 | ns |
| | | | -40°C to +125°C | | | 180 | ns |
| t_{OFF} | Turn-off time from control input | $V_S = 8\text{ V}$ $R_L = 300\ \Omega$, $C_L = 35\text{ pF}$ | 25°C | | 150 | 180 | ns |
| | | | -40°C to +85°C | | | 205 | ns |
| | | | -40°C to +125°C | | | 220 | ns |
| $t_{ON(VDD)}$ | Device turn on time (V_{DD} to output) | V_{DD} rise time = 1 μs $R_L = 300\ \Omega$, $C_L = 35\text{ pF}$ | -40°C to +125°C | | 0.2 | | ms |
| t_{PD} | Propagation delay | $R_L = 50\ \Omega$, $C_L = 5\text{ pF}$ | 25°C | | 1000 | | ps |
| Q_{INJ} | Charge injection | $V_S = 6\text{ V}$, $C_L = 100\text{ pF}$ | 25°C | | -4 | | pC |
| O_{ISO} | Off-isolation | $R_L = 50\ \Omega$, $C_L = 5\text{ pF}$ $V_S = 6\text{ V}$, $f = 100\text{ kHz}$ | 25°C | | -65 | | dB |
| O_{ISO} | Off-isolation | $R_L = 50\ \Omega$, $C_L = 5\text{ pF}$ $V_S = 6\text{ V}$, $f = 1\text{ MHz}$ | 25°C | | -45 | | dB |
| BW | -3 dB Bandwidth | $R_L = 50\ \Omega$, $C_L = 5\text{ pF}$ $V_S = 6\text{ V}$ | 25°C | | 23 | | MHz |
| I_L | Insertion loss | $R_L = 50\ \Omega$, $C_L = 5\text{ pF}$ $V_S = 6\text{ V}$, $f = 1\text{ MHz}$ | 25°C | | -0.18 | | dB |
| ACPSRR | AC Power Supply Rejection Ratio | $V_{PP} = 0.62\text{ V}$ on V_{DD} and V_{SS} $R_L = 50\ \Omega$, $C_L = 5\text{ pF}$, $f = 1\text{ MHz}$ | 25°C | | -40 | | dB |
| THD+N | Total Harmonic Distortion + Noise | $V_{PP} = 6\text{ V}$, $V_{BIAS} = 6\text{ V}$ $R_L = 10\text{ k}\Omega$, $C_L = 5\text{ pF}$, $f = 20\text{ Hz}$ to 20 kHz | 25°C | | 0.0009 | | % |
| $C_{S(OFF)}$ | Source off capacitance | $V_S = 6\text{ V}$, $f = 1\text{ MHz}$ | 25°C | | 53 | | pF |
| $C_{D(OFF)}$ | Drain off capacitance | $V_S = 6\text{ V}$, $f = 1\text{ MHz}$ | 25°C | | 75 | | pF |
| $C_{S(ON)}$, $C_{D(ON)}$ | On capacitance | $V_S = 6\text{ V}$, $f = 1\text{ MHz}$ | 25°C | | 240 | | pF |

6.14 Typical Characteristics

at $T_A = 25^\circ\text{C}$



图 6-1. On-Resistance vs Source or Drain Voltage - Dual Supply



图 6-2. On-Resistance vs Source or Drain Voltage - Dual Supply

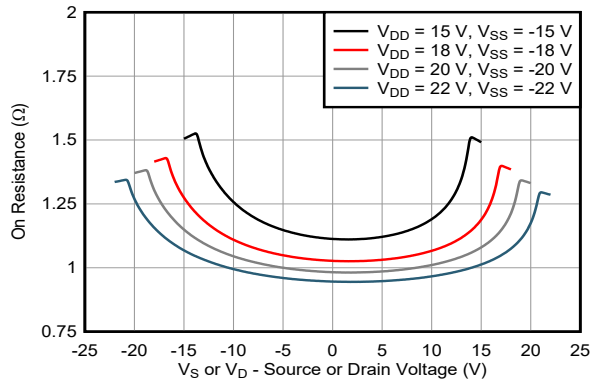

图 6-3. On-Resistance vs Source or Drain Voltage - Single Supply

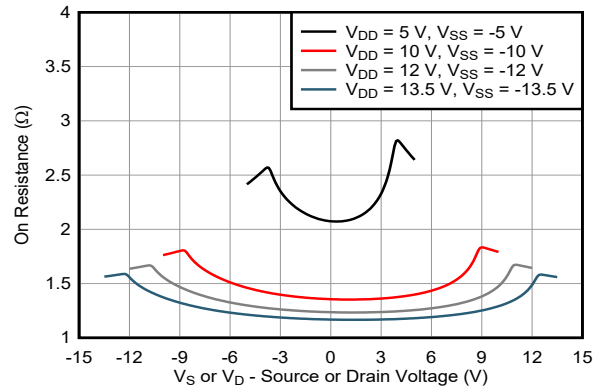

图 6-4. On-Resistance vs Source or Drain Voltage - Single Supply

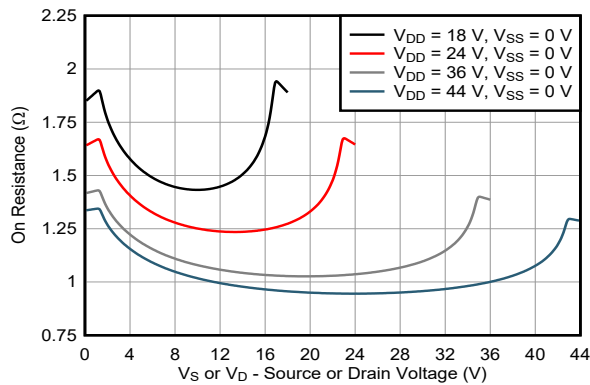

图 6-5. On-Resistance vs Temperature

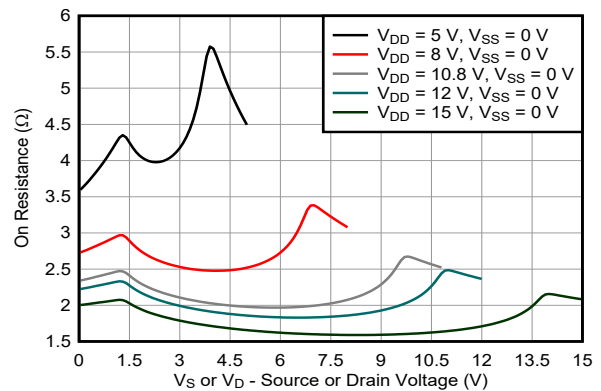

图 6-6. On-Resistance vs Temperature

6.14 Typical Characteristics (continued)

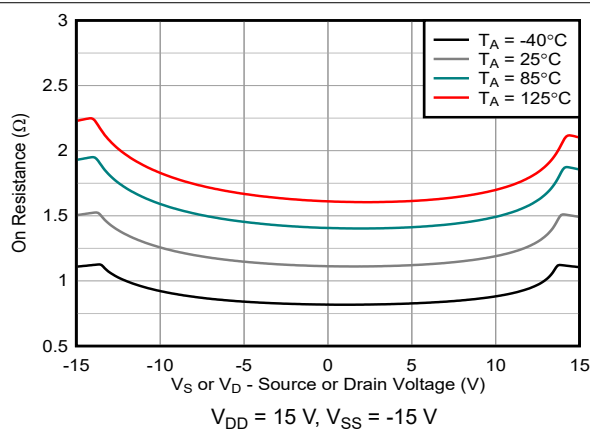
at $T_A = 25^\circ\text{C}$

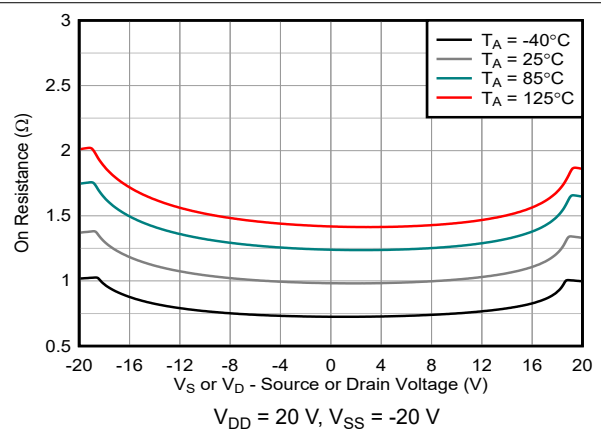

图 6-7. On-Resistance vs Temperature



图 6-8. On-Resistance vs Temperature

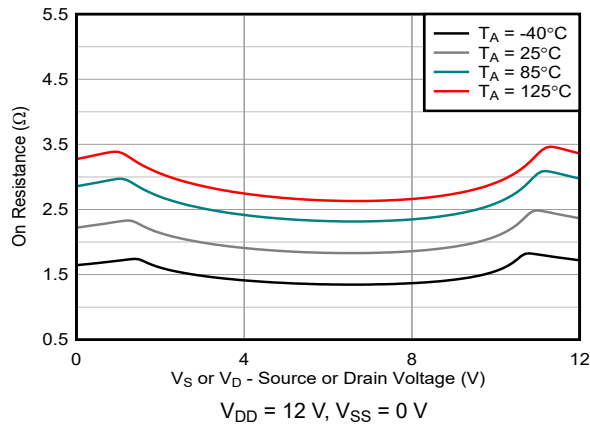

图 6-9. Leakage Current vs Temperature

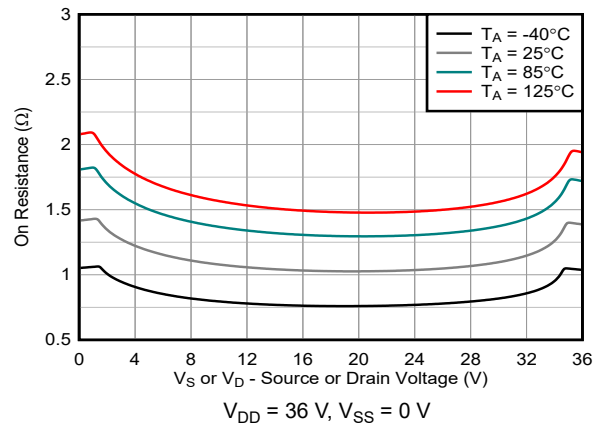

图 6-10. Leakage Current vs Temperature

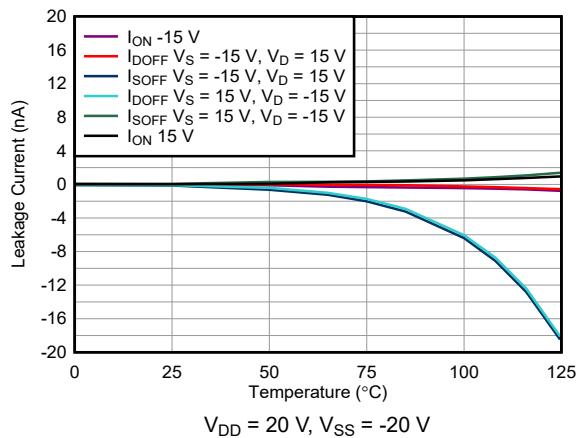

图 6-11. Leakage Current vs Temperature

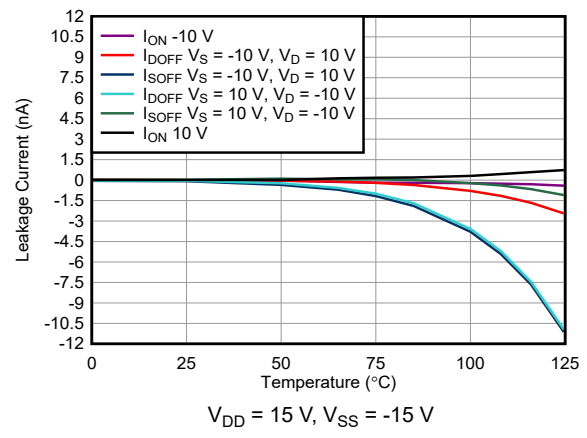

图 6-12. Leakage Current vs Temperature

6.14 Typical Characteristics (continued)

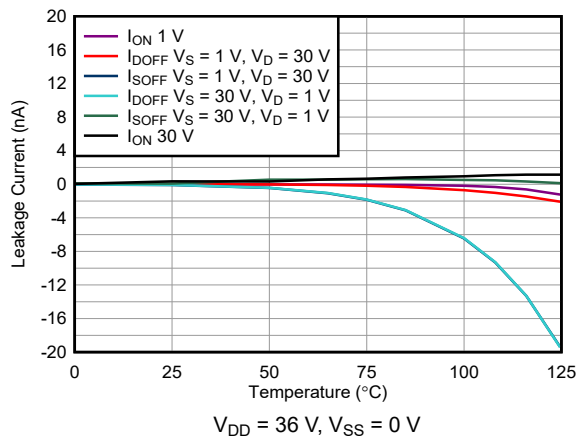
at $T_A = 25^\circ\text{C}$

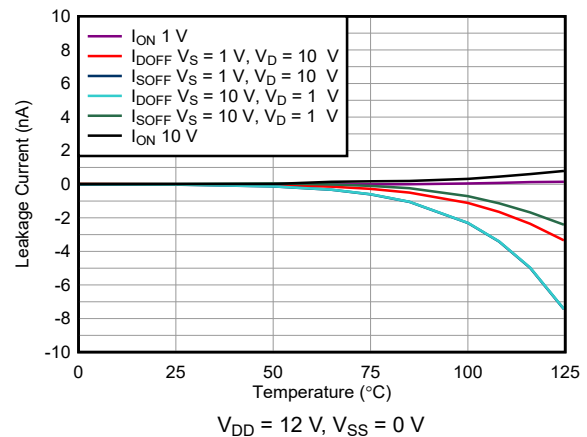

图 6-13. Supply Current vs Logic Voltage



图 6-14. Charge Injection vs Source Voltage - Dual Supplies

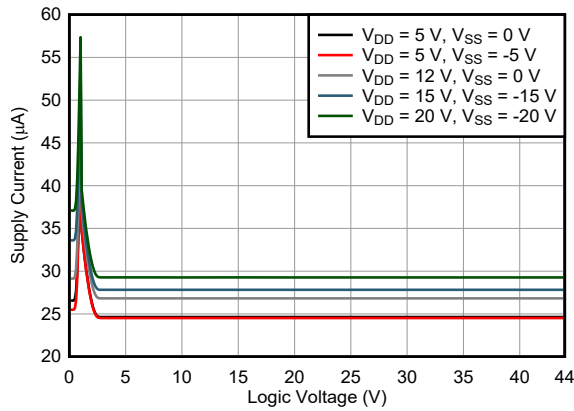

图 6-15. Charge Injection vs Drain Voltage - Dual Supplies

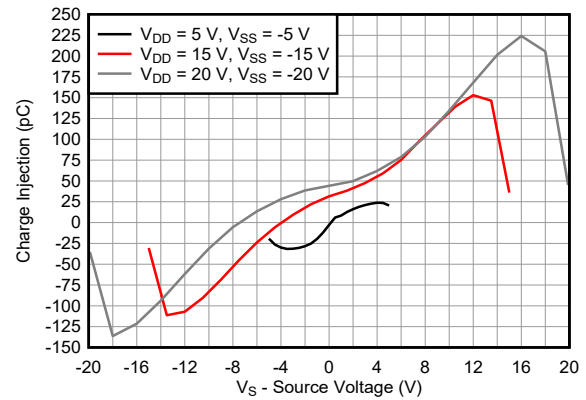

图 6-16. Charge Injection vs Source Voltage - Single Supplies

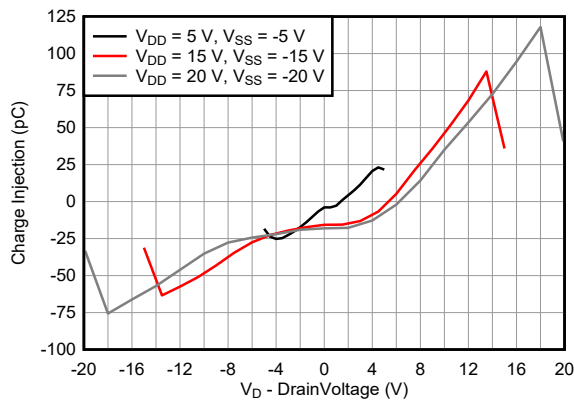

图 6-17. Charge Injection vs Drain Voltage - Single Supplies

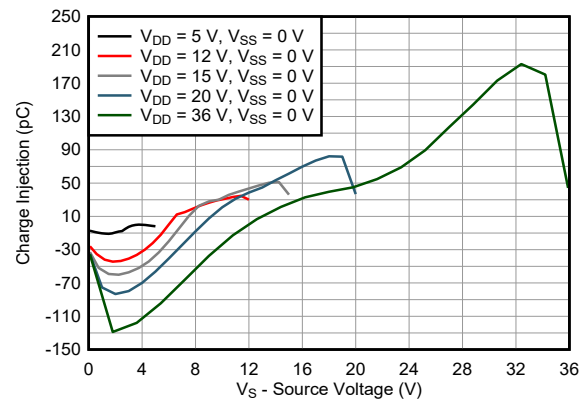

图 6-18. T_{ON} and T_{OFF} vs Temperature

6.14 Typical Characteristics (continued)

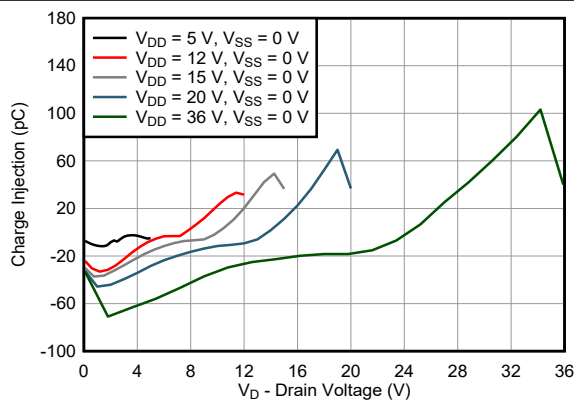
at $T_A = 25^\circ\text{C}$

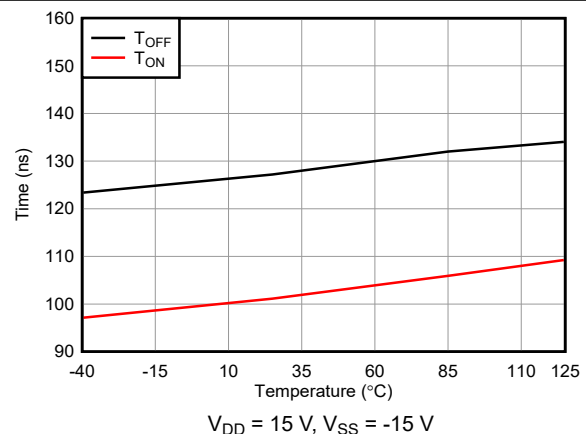

图 6-19. T_{ON} and T_{OFF} vs Temperature



图 6-20. Off-Isolation vs Frequency

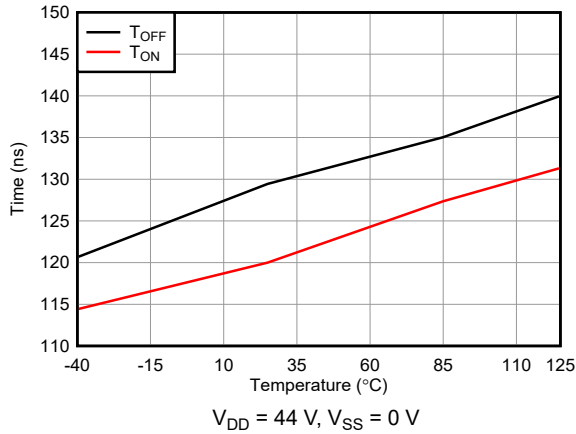

图 6-21. THD+N vs Frequency (Dual Supplies)

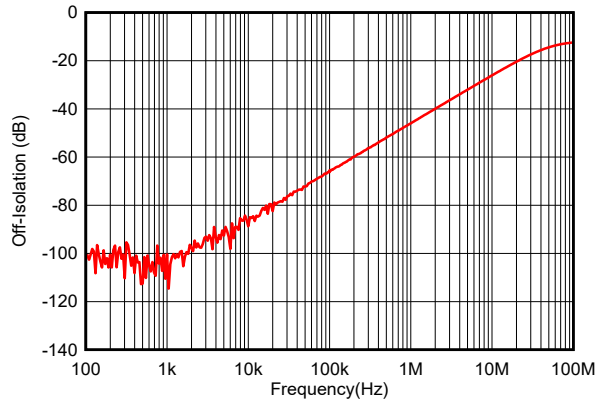

图 6-22. THD+N vs Frequency (Single Supplies)

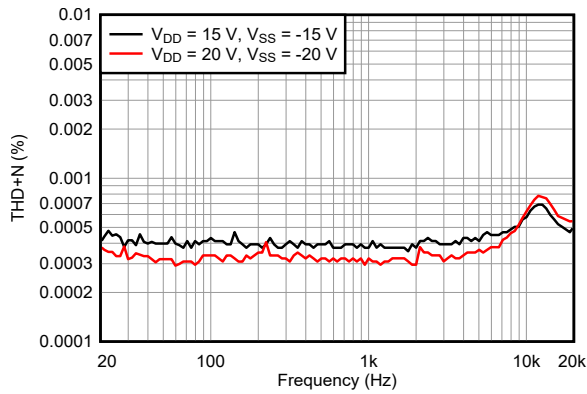

图 6-23. On Response vs Frequency

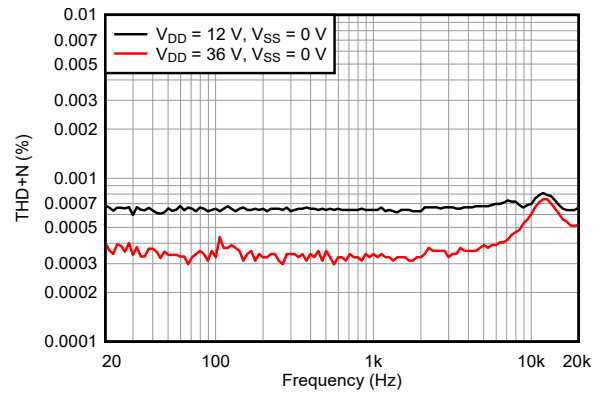

图 6-24. ACPSRR vs Frequency

6.14 Typical Characteristics (continued)

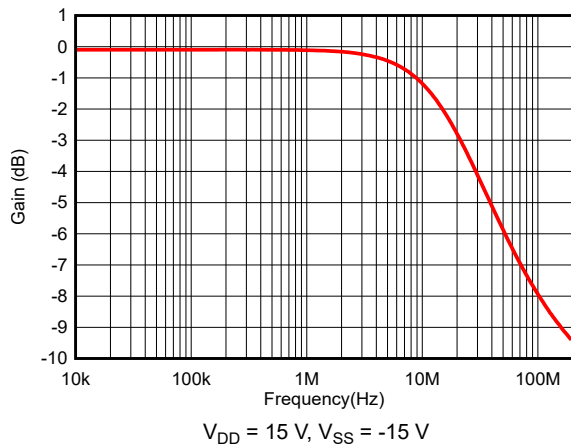
at $T_A = 25^\circ\text{C}$

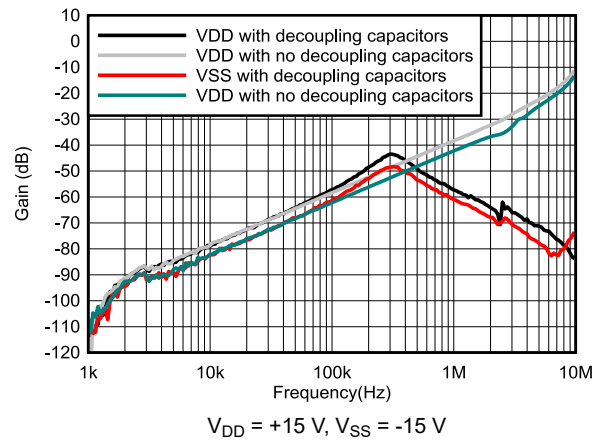

图 6-25. Capacitance vs Source Voltage or Drain Voltage



图 6-26. Capacitance vs Source Voltage or Drain Voltage

7 Parameter Measurement Information

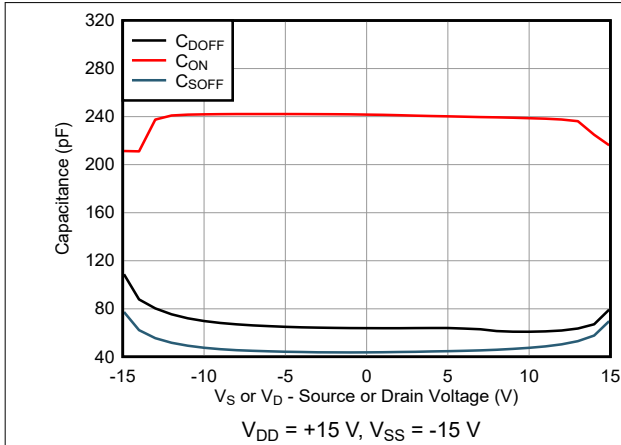
7.1 On-Resistance

The On-Resistance of a device is the ohmic resistance between the source (Sx) and drain (Dx) pins of the device. The On-Resistance varies with input voltage and supply voltage. The symbol R_{ON} is used to denote On-Resistance. 图 7-1 shows the measurement setup used to measure R_{ON} . Voltage (V) and current (I_{SD}) are measured using this setup, and R_{ON} is computed with $R_{ON} = V / I_{SD}$.

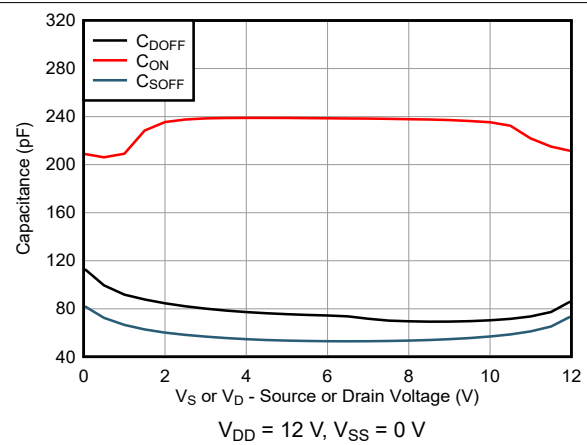

图 7-1. On-Resistance Measurement Setup

7.2 Off-Leakage Current

There are two types of leakage currents associated with a switch during the off state:

1. Source Off-Leakage current.
2. Drain Off-Leakage current.

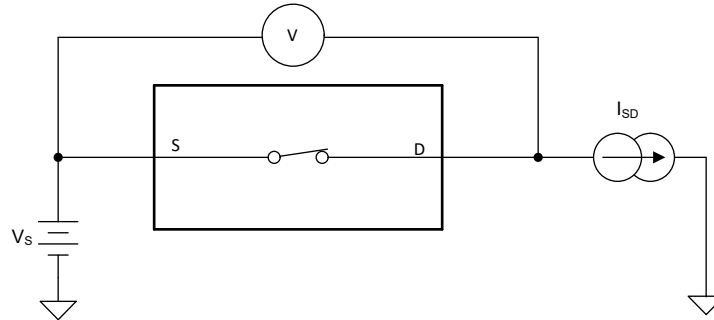
Source leakage current is defined as the leakage current flowing into or out of the source pin when the switch is off. This current is denoted by the symbol $I_{S(OFF)}$.

Drain leakage current is defined as the leakage current flowing into or out of the drain pin when the switch is off. This current is denoted by the symbol $I_{D(OFF)}$.

图 7-2 shows the setup used to measure both Off-Leakage currents.



图 7-2. Off-Leakage Measurement Setup

7.3 On-Leakage Current

Source on-leakage current is defined as the leakage current flowing into or out of the source pin when the switch is on. This current is denoted by the symbol $I_{S(ON)}$.

Drain on-leakage current is defined as the leakage current flowing into or out of the drain pin when the switch is on. This current is denoted by the symbol $I_{D(ON)}$.

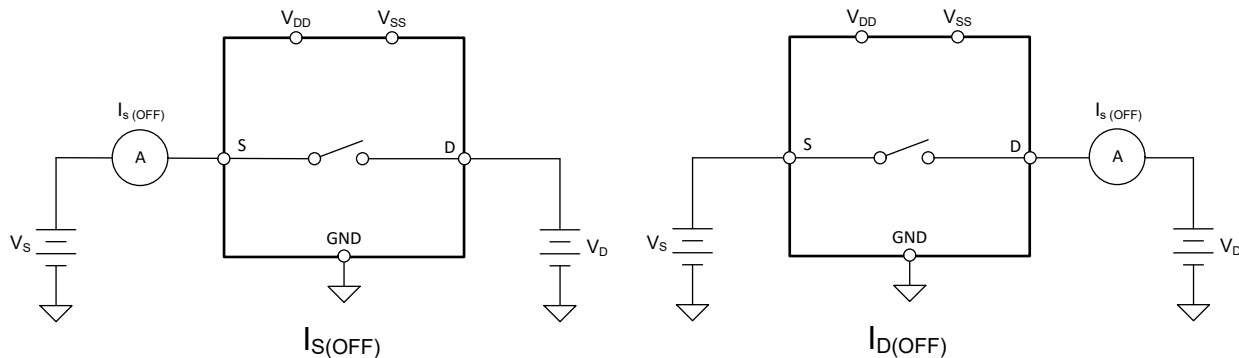
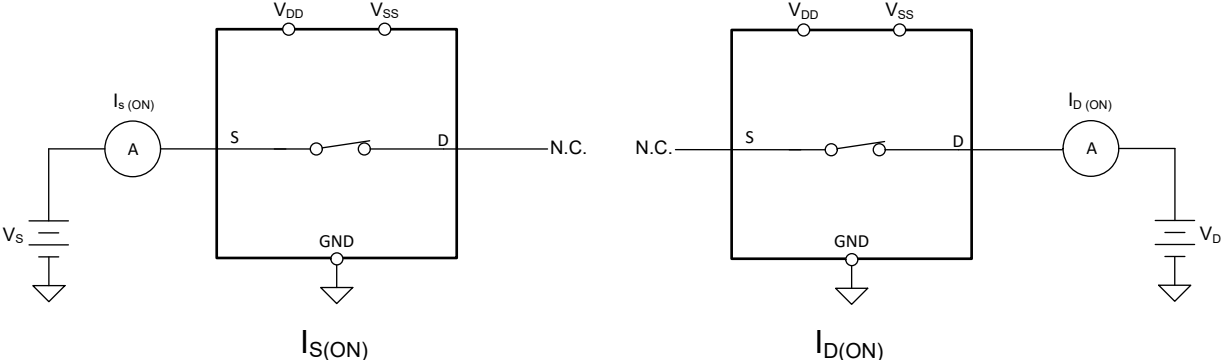
Either the source pin or drain pin is left floating during the measurement.  shows the circuit used for measuring the on-leakage current, denoted by $I_{S(ON)}$ or $I_{D(ON)}$.



图 7-3. On-Leakage Measurement Setup

7.4 t_{ON} and t_{OFF} Time

Turn-on time is defined as the time taken by the output of the device to rise to 90% after the enable has risen past the logic threshold. The 90% measurement is utilized to provide the timing of the device. System level timing can then account for the time constant added from the load resistance and load capacitance.  shows the setup used to measure turn-on time, denoted by the symbol t_{ON} .

Turn-off time is defined as the time taken by the output of the device to fall to 10% after the enable has fallen past the logic threshold. The 10% measurement is utilized to provide the timing of the device. System level timing can then account for the time constant added from the load resistance and load capacitance.  shows the setup used to measure turn-off time, denoted by the symbol t_{OFF} .

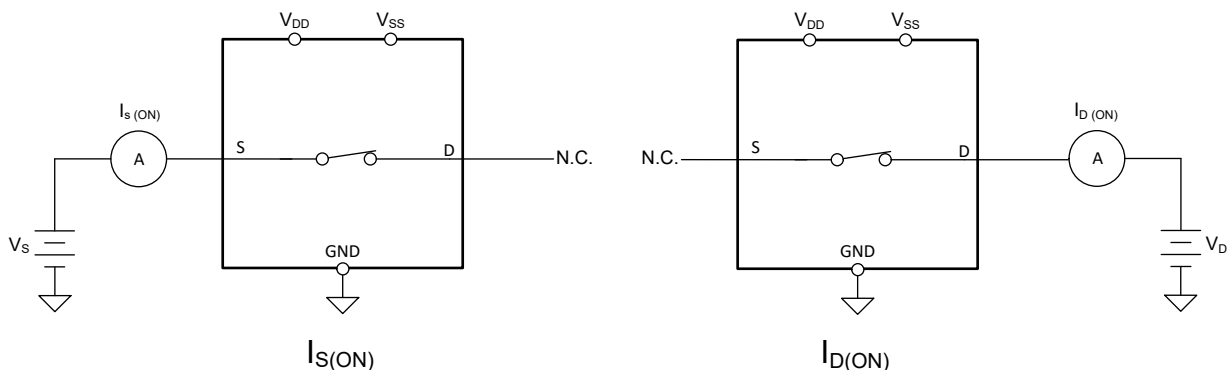
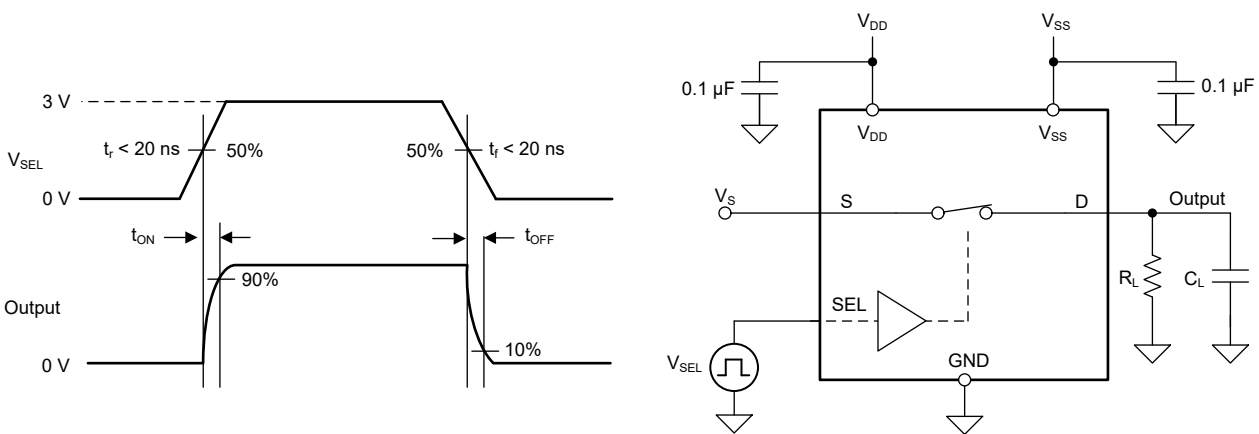
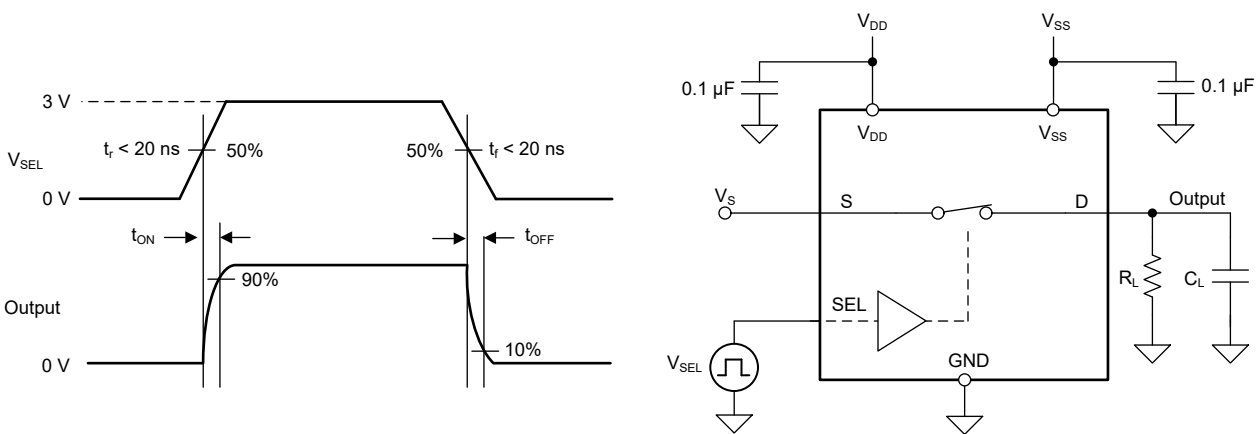

图 7-4. Turn-On and Turn-Off Time Measurement Setup

7.5 $t_{ON(VDD)}$ Time

The $t_{ON(VDD)}$ time is defined as the time taken by the output of the device to rise to 90% after the supply has risen past the supply threshold. The 90% measurement is used to provide the timing of the device turning on in the system. 图 7-5 shows the setup used to measure turn on time, denoted by the symbol $t_{ON(VDD)}$.

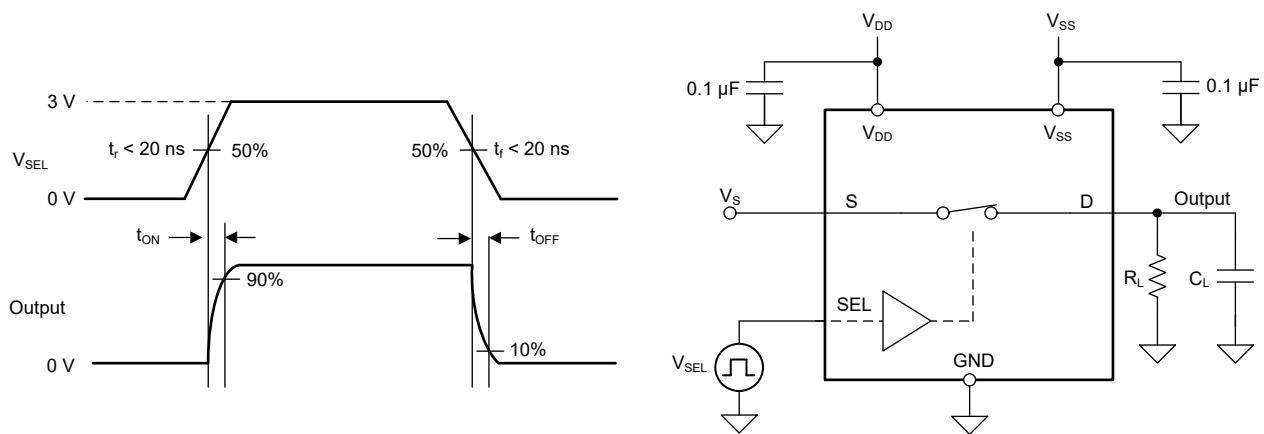

图 7-5. $t_{ON(VDD)}$ Time Measurement Setup

7.6 Propagation Delay

Propagation delay is defined as the time taken by the output of the device to rise or fall 50% after the input signal has risen or fallen past the 50% threshold. 图 7-6 and 方程式 1 shows the setup used to measure propagation delay, denoted by the symbol t_{PD} .

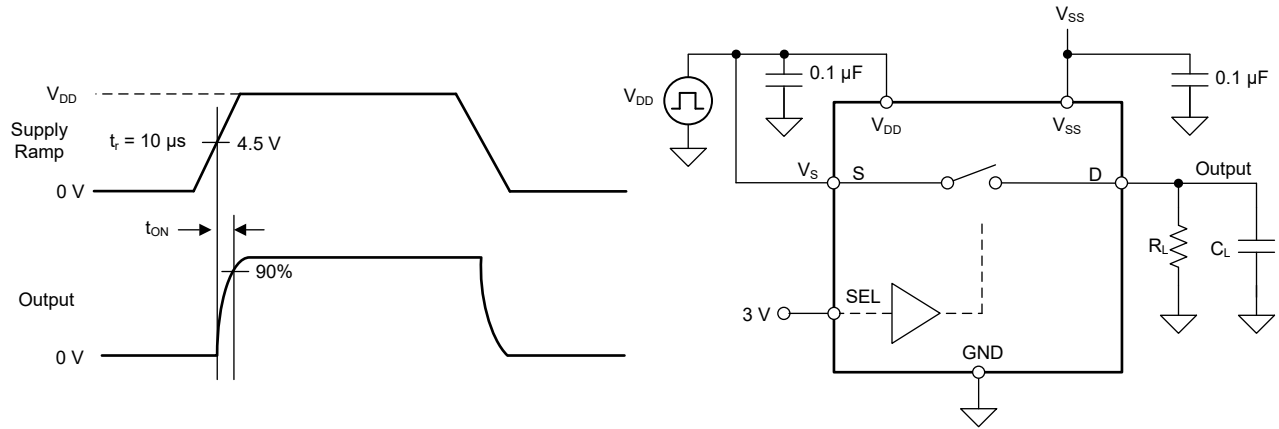

图 7-6. Propagation Delay Measurement Setup

$$t_{Prop Delay} = \max(t_{PD 1}, t_{PD 2}) \quad (1)$$

7.7 Charge Injection

The TMUX720x devices have a transmission-gate topology. Any mismatch in capacitance between the NMOS and PMOS transistors results in a charge injected into the drain or source during the falling or rising edge of the gate signal. The amount of charge injected into the source or drain of the device is known as charge injection, and is denoted by the symbol Q_C . 图 7-7 shows the setup used to measure charge injection from source (Sx) to drain (Dx).

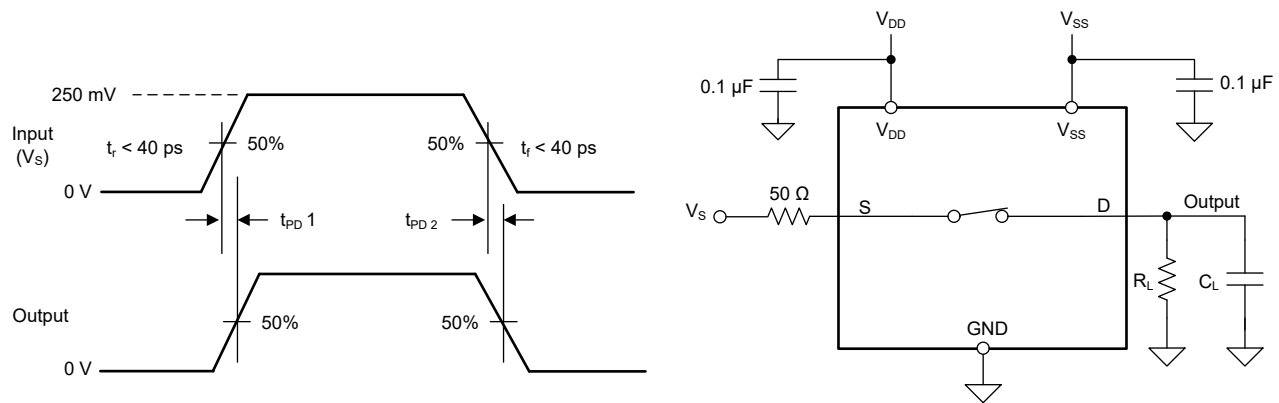

图 7-7. Charge-Injection Measurement Setup

7.8 Off Isolation

Off isolation is defined as the ratio of the signal at the drain pin (Dx) of the device when a signal is applied to the source pin (Sx) of an off-channel. The characteristic impedance, Z_0 , for the measurement is 50Ω . 图 7-8 and 方程式 2 shows the setup used to measure off isolation. Use off isolation equation to compute off isolation.

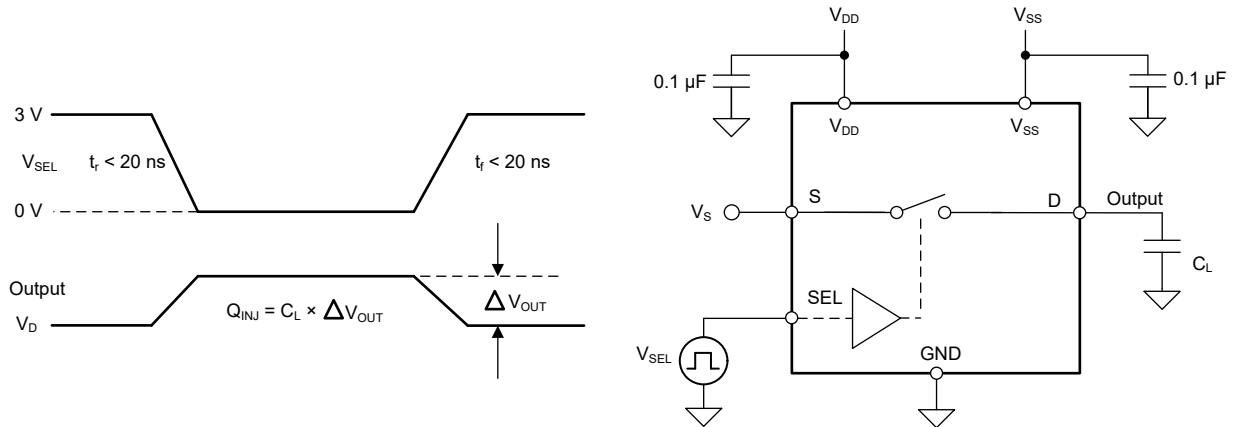

图 7-8. Off Isolation Measurement Setup

$$Off - Isolation = 20 \times \text{Log} \left(\frac{V_{OUT}}{V_S} \right) \tag{2}$$

7.9 Bandwidth

Bandwidth is defined as the range of frequencies that are attenuated by less than 3 dB when the input is applied to the source pin (Sx) of an on-channel, and the output is measured at the drain pin (Dx) of the device. The characteristic impedance, Z_0 , for the measurement is 50 Ω . 图 7-9 和 方程式 3 shows the setup used to measure bandwidth.

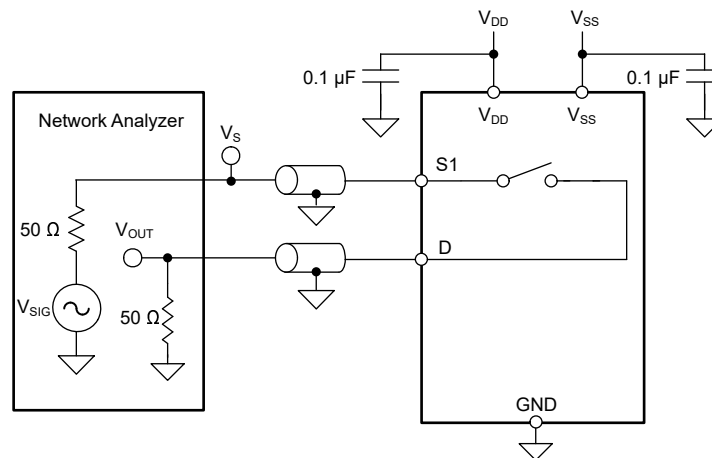

图 7-9. Bandwidth Measurement Setup

$$Bandwidth = 20 \times \text{Log} \left(\frac{V_{OUT}}{V_S} \right) \quad (3)$$

7.10 THD + Noise

The total harmonic distortion (THD) of a signal is a measurement of the harmonic distortion, and is defined as the ratio of the sum of the powers of all harmonic components to the power of the fundamental frequency at the mux output. The On-Resistance of the device varies with the amplitude of the input signal and results in distortion when the drain pin is connected to a low-impedance load. Total harmonic distortion plus noise is denoted as THD + N.

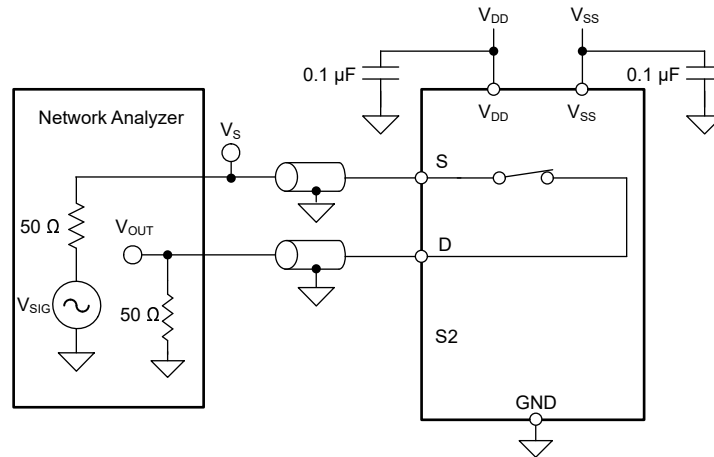

图 7-10. THD + N Measurement Setup

7.11 Power Supply Rejection Ratio (PSRR)

PSRR measures the ability of a device to prevent noise and spurious signals that appear on the supply voltage pin from coupling to the output of the switch. The DC voltage on the device supply is modulated by a sine wave of 100 mV_{PP}. The ratio of the amplitude of signal on the output to the amplitude of the modulated signal is the AC PSRR.

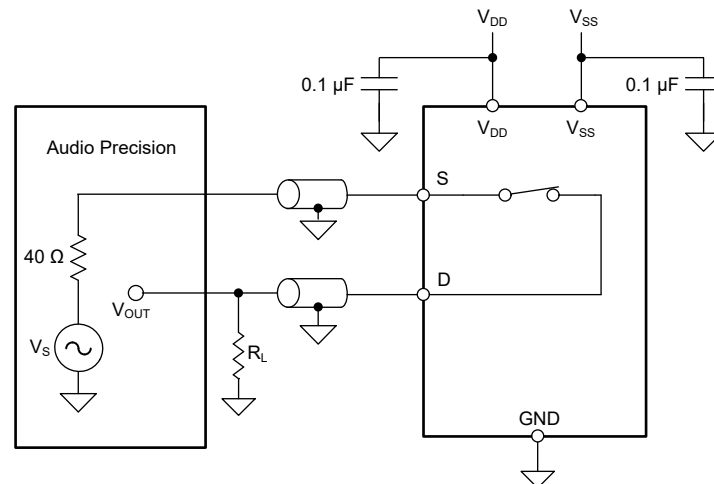

图 7-11. AC PSRR Measurement Setup

$$PSRR = 20 \times \text{Log} \left(\frac{V_{OUT}}{V_{IN}} \right) \quad (4)$$

8 Detailed Description

8.1 Overview

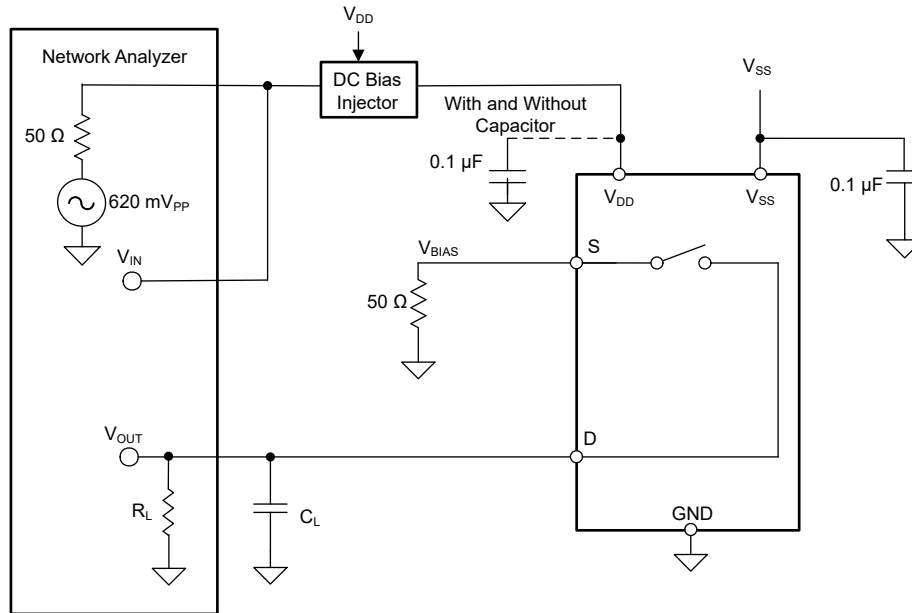
The TMUX720x are 1:1, 1-channel switches. The switch is turned on or turned off based on the state of the select pin.

8.2 Functional Block Diagram

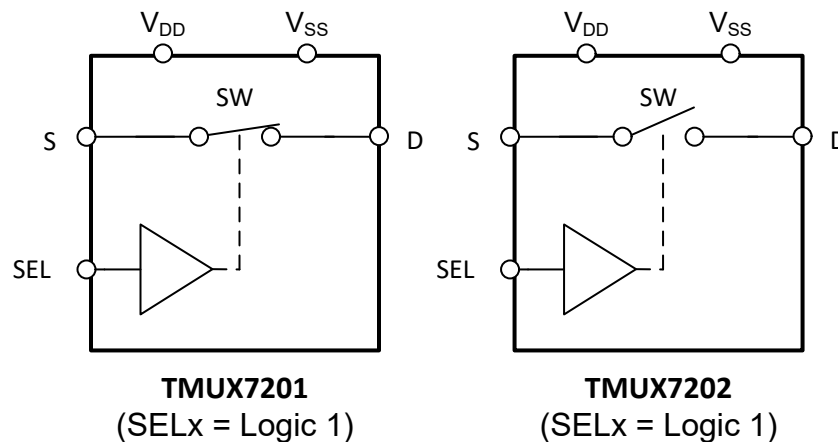

8.3 Feature Description

8.3.1 Bidirectional Operation

The TMUX720x conducts equally well from source (S) to drain (D) or from drain (D) to source (S). The switch has very similar characteristics in both directions and supports both analog and digital signals.

8.3.2 Rail-to-Rail Operation

The valid signal path input and output voltage for TMUX720x ranges from V_{SS} to V_{DD} .

8.3.3 1.8 V Logic Compatible Inputs

The TMUX720x has 1.8 V logic compatible control for all logic control inputs. 1.8 V logic level inputs allows the device to interface with processors that have lower logic I/O rails and eliminates the need for an external translator, which saves both space and BOM cost. For more information on 1.8 V logic implementations, refer to [Simplifying Design with 1.8 V logic Muxes and Switches](#).

8.3.4 Integrated Pull-Down Resistor on Logic Pins

The TMUX7201 and TMUX7202 have internal weak Pull-Down resistors to GND to ensure the logic pins are not left floating. The value of this Pull-Down resistor is approximately $4\text{ M}\Omega$, but is clamped to about $1\ \mu\text{A}$ at higher voltages. This feature integrates an external component and reduces system size and cost.

8.3.5 Fail-Safe Logic

The TMUX720x supports Fail-Safe Logic on the control input pins (SEL) allowing for operation up to 44 V above ground, regardless of the state of the supply pins. This feature allows voltages on the control pins to be applied before the supply pin, protecting the device from potential damage. Fail-Safe Logic minimizes system complexity by removing the need for power supply sequencing on the logic control pins. For example, the Fail-Safe Logic feature allows the logic input pins of the TMUX720x to be ramped to +44 V while V_{DD} and $V_{SS} = 0\text{ V}$. The logic control inputs are protected against positive faults of up to +44 V in powered-off condition, but do not offer protection against negative overvoltage conditions.

8.3.6 Latch-Up Immune

Latch-up is a condition where a low impedance path is created between a supply pin and ground. This condition is caused by a trigger (current injection or overvoltage), but once activated, the low impedance path remains even after the trigger is no longer present. This low impedance path may cause system upset or catastrophic damage due to excessive current levels. The Latch-Up condition typically requires a power cycle to eliminate the low impedance path.

The TMUX720x family of devices are constructed on silicon-on-insulator (SOI) based process where an oxide layer is added between the PMOS and NMOS transistor of each CMOS switch to prevent parasitic structures from forming. The oxide layer is also known as an insulating trench and prevents triggering of latch up events due to overvoltage or current injections. The Latch-Up immunity feature allows the TMUX720x family of switches and multiplexers to be used in harsh environments.

8.3.7 Ultra-Low Charge Injection

图 8-1 shows how the TMUX720x devices have a transmission gate topology. Any mismatch in the stray capacitance associated with the NMOS and PMOS causes an output level change whenever the switch is opened or closed.



图 8-1. Transmission Gate Topology

The TMUX720x contains specialized architecture to reduce charge injection on the Drain (Dx). To further reduce charge injection in a sensitive application, a compensation capacitor (C_p) can be added on the Source (S). By design, the excess charge from the switch transition will be pushed into the compensation capacitor on the Source (S) instead of the Drain (D). As a general rule, C_p should be 20x larger than the equivalent load capacitance on the Drain (D). 图 8-2 shows charge injection variation with different compensation capacitors on the Source side. This plot was captured on the TMUX7219 as part of the TMUX72xx family with a 100 pF load capacitance.

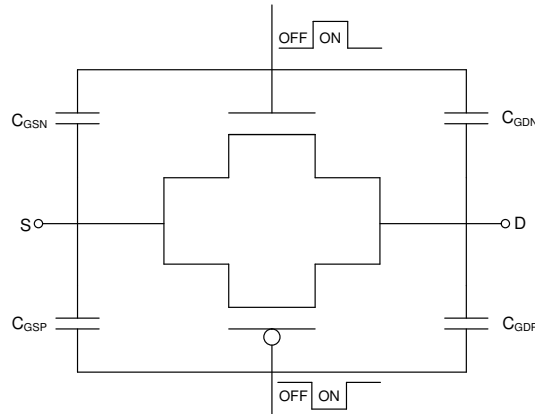

图 8-2. Charge Injection Compensation

8.4 Device Functional Modes

When the SEL pin of the TMUX720x is pulled high, the switches will close. When the SEL pin is pulled low, the switches will open. The control pins can be as high as 44 V.

The TMUX720x can operate without any external components except for the supply decoupling capacitors. The SEL pin has an internal Pull-Down resistor of 4 M Ω . If unused, then the SEL pin must be tied to GND so the device does not consume additional current as highlighted in [Implications of Slow or Floating CMOS Inputs](#).

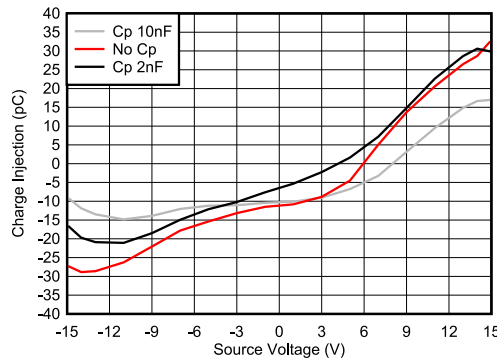
8.5 Truth Tables

表 8-1 provides the truth tables for the TMUX720x.

表 8-1. TMUX720x Truth Table

| SEL | Selected Source Connected To Drain (D) – TMUX7201 | Selected Source Connected To Drain (D) – TMUX7202 |
|-----|---|---|
| 0 | All sources are off (HI-Z) | S |
| 1 | S | All sources are off (HI-Z) |

9 Application and Implementation

备注

Information in the following applications sections is not part of the TI component specification, and TI does not warrant its accuracy or completeness. TI's customers are responsible for determining suitability of components for their purposes, as well as validating and testing their design implementation to confirm system functionality.

9.1 Application Information

TMUX720x is part of the precision switches and multiplexers family of devices. TMUX720x offers low RON, low on and off leakage currents and Ultra-Low charge injection performance. These properties make TMUX720x ideal for implementing high precision industrial systems requiring selection of one of two inputs or outputs.

9.2 Typical Applications

9.2.1 TIA Feedback Gain Switch

One application of the TMUX720x is to configure the feedback on a discrete transimpedance amplifier (TIA) implementation. Often, TIAs are used in applications such as photodiode inputs, which then feeds into an ADC or MCU/processor. Depending on the expected strength of the photodiode input, and the needed accuracy, multiple gain levels are needed. A switch like the TMUX720x allows for different gain values to be selected, changing the level of amplifications. This solution can be scaled, but as much as needed for multiple gain options.

图 9-1 shows the TMUX720x configured with a precision op amp to enable multiple gains.



图 9-1. TIA Feedback Control

9.2.1.1 Design Requirements

For this design example, use the parameters listed in 表 9-1.

表 9-1. Design Parameters

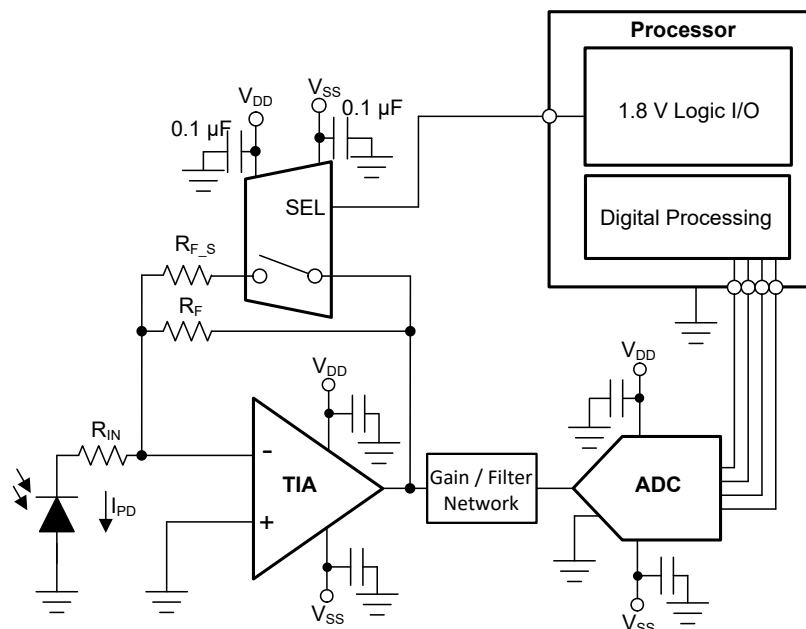
| PARAMETERS | VALUES |
|--------------------------|------------------------------------|
| Supply (V_{DD}) | 15 V |
| Supply (V_{SS}) | -15 V |
| MUX I/O signal range | -15 V to 15 V (Rail-to-Rail) |
| Control logic thresholds | 1.8 V compatible (up to V_{DD}) |

9.2.1.2 Detailed Design Procedure

图 9-1 shows an application that demonstrates how the TMUX720x can be used to select the gain of a TIA amplifier. Here R_F is used to prevent any open loop configuration. For the lowest error, the R_{ON} of the switch should be much smaller than R_{F_S} , as this will scale linearly with the potential error.

The TMUX720x can support 1.8 V logic signals on the control input, allowing the device to interface with low logic controls of an FPGA or MCU. The TMUX720x can operate without any external components except for the supply decoupling capacitors. The select pin has an internal Pull-Down resistor to prevent floating input logic. All inputs to the switch must fall within the recommend operating conditions of the TMUX720x including signal range and continuous current. For this design with a positive supply of 15 V on V_{DD} and negative supply of -15 V on V_{SS} , the signal range can be 15 V to -15 V. The maximum continuous current (I_{DC}) can be up to 330 mA (for wide-range current measurement, see the [Recommended Operating Conditions](#) section).

9.2.1.3 Application Curves

The low on and off leakage currents of TMUX720x and Ultra-Low charge injection performance make this device ideal for implementing high precision industrial systems. The TMUX720x contains specialized architecture to reduce charge injection on the source (S_x) (for more details, see 节 8.3.7). 图 9-2 shows the plot for the charge injection versus source voltage for the TMUX720x.



图 9-2. Charge Injection vs Source Voltage

9.3 Power Supply Recommendations

The TMUX720x operates across a wide supply range of $\pm 4.5\text{ V}$ to $\pm 22\text{ V}$ (4.5 V to 44 V in single-supply mode). The device also performs well with asymmetrical supplies such as $V_{DD} = 12\text{ V}$ and $V_{SS} = -5\text{ V}$.

Power-supply bypassing improves noise margin and prevents switching noise propagation from the supply rails to other components. Good power-supply decoupling is important to achieve optimum performance. For improved supply noise immunity, use a supply decoupling capacitor ranging from $0.1\ \mu\text{F}$ to $10\ \mu\text{F}$ at both the V_{DD} and V_{SS} pins to ground. Place the bypass capacitors as close to the power supply pins of the device as possible using low-impedance connections. TI recommends using multi-layer ceramic chip capacitors (MLCCs) that offer low equivalent series resistance (ESR) and inductance (ESL) characteristics for power-supply decoupling purposes. For very sensitive systems, or for systems in harsh noise environments, avoiding the use of vias for connecting the capacitors to the device pins may offer superior noise immunity. The use of multiple vias in parallel lowers the overall inductance and is beneficial for connections to ground and power planes. Always ensure the ground (GND) connection is established before supplies are ramped.

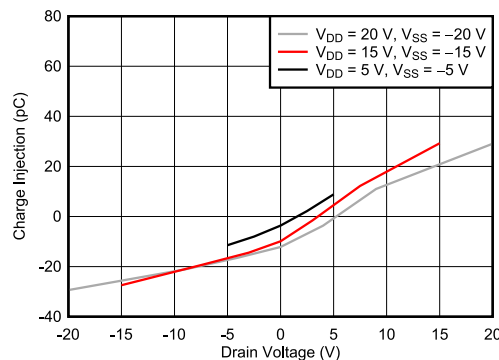
9.4 Layout

9.4.1 Layout Guidelines

When a PCB trace turns a corner at a 90° angle, a reflection can occur. A reflection occurs primarily because of the change of width of the trace. At the apex of the turn, the trace width increases to 1.414 times the width. This increase upsets the transmission-line characteristics, especially the distributed capacitance and self-inductance of the trace which results in the reflection. Not all PCB traces can be straight and therefore some traces must turn corners. [Figure 9-3](#) shows progressively better techniques of rounding corners. Only the last example (BEST) maintains constant trace width and minimizes reflections.



图 9-3. Trace Example

Route high-speed signals using a minimum of vias and corners which reduces signal reflections and impedance changes. When a via must be used, increase the clearance size around it to minimize its capacitance. Each via introduces discontinuities in the signal's transmission line and increases the chance of picking up interference from the other layers of the board. Be careful when designing test points, through-hole pins are not recommended at high frequencies.

[Figure 9-4](#) shows an example of a PCB layout with the TMUX720x. Some key considerations are as follows:

- For reliable operation, connect a decoupling capacitor ranging from $0.1\ \mu\text{F}$ to $10\ \mu\text{F}$ between V_{DD}/V_{SS} and GND. We recommend a $0.1\ \mu\text{F}$ and $1\ \mu\text{F}$ capacitor, placing the lowest value capacitor as close to the pin as possible. Make sure that the capacitor voltage rating is sufficient for the supply voltage.
- Keep the input lines as short as possible.
- Use a solid ground plane to help reduce electromagnetic interference (EMI) noise pickup.
- Do not run sensitive analog traces in parallel with digital traces. Avoid crossing digital and analog traces if possible, and only make perpendicular crossings when necessary.
- Using multiple vias in parallel will lower the overall inductance and is beneficial for connection to ground planes.

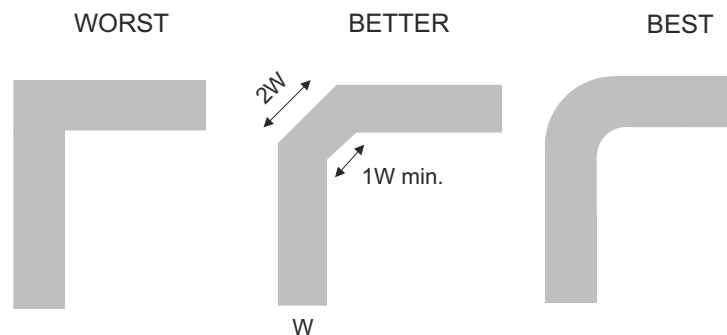
9.4.2 Layout Example



图 9-4. TMUX720x Layout Example

10 Device and Documentation Support

10.1 Documentation Support

10.1.1 Related Documentation

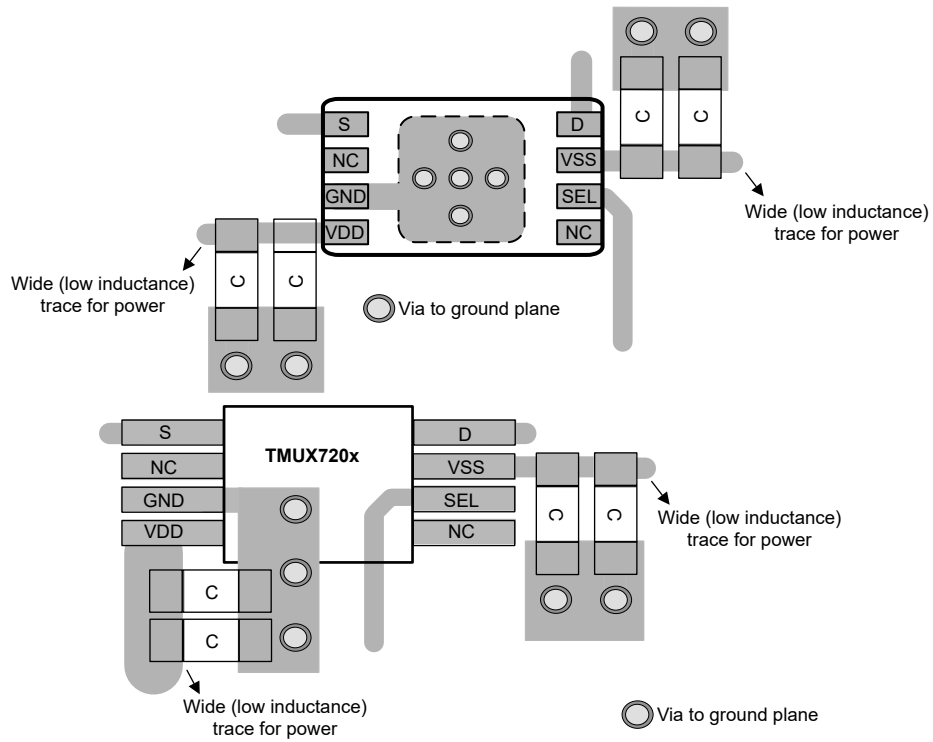
For related documentation, see the following:

- Texas Instruments, [Improve Stability Issues with Low CON Multiplexers](#) application brief
- Texas Instruments, [Improving Signal Measurement Accuracy in Automated Test Equipment](#) application brief
- Texas Instruments, [Multiplexers and Signal Switches Glossary](#) application note
- Texas Instruments, [QFN/SON PCB Attachment](#) application note
- Texas Instruments, [Quad Flatpack No-Lead Logic Packages](#) application note
- Texas Instruments, [Simplifying Design with 1.8 V logic Muxes and Switches](#) application brief
- Texas Instruments, [System-Level Protection for High-Voltage Analog Multiplexers](#) application notes
- Texas Instruments, [True Differential, 4 x 2 MUX, Analog Front End, Simultaneous-Sampling ADC Circuit circuit design](#)

10.2 接收文档更新通知

要接收文档更新通知，请导航至 [ti.com](https://www.ti.com) 上的器件产品文件夹。点击 [订阅更新](#) 进行注册，即可每周接收产品信息更改摘要。有关更改的详细信息，请查看任何已修订文档中包含的修订历史记录。

10.3 支持资源

TI E2E™ [支持论坛](#) 是工程师的重要参考资料，可直接从专家获得快速、经过验证的解答和设计帮助。搜索现有解答或提出自己的问题可获得所需的快速设计帮助。

链接的内容由各个贡献者“按原样”提供。这些内容并不构成 TI 技术规范，并且不一定反映 TI 的观点；请参阅 TI 的《[使用条款](#)》。

10.4 Trademarks

TI E2E™ is a trademark of Texas Instruments.

所有商标均为其各自所有者的财产。

10.5 静电放电警告



静电放电 (ESD) 会损坏这个集成电路。德州仪器 (TI) 建议通过适当的预防措施处理所有集成电路。如果不遵守正确的处理和安装程序，可能会损坏集成电路。

ESD 的损坏小至导致微小的性能降级，大至整个器件故障。精密的集成电路可能更容易受到损坏，这是因为非常细微的参数更改都可能会导致器件与其发布的规格不相符。

10.6 术语表

[TI 术语表](#) 本术语表列出并解释了术语、首字母缩略词和定义。

11 Mechanical, Packaging, and Orderable Information

The following pages include mechanical, packaging, and orderable information. This information is the most current data available for the designated devices. This data is subject to change without notice and revision of this document. For browser-based versions of this data sheet, refer to the left-hand navigation.

PACKAGING INFORMATION

| Orderable Device | Status (1) | Package Type | Package Drawing | Pins | Package Qty | Eco Plan (2) | Lead finish/ Ball material (6) | MSL Peak Temp (3) | Op Temp (°C) | Device Marking (4/5) | Samples |
|------------------|---------------|--------------|-----------------|------|-------------|-----------------|--------------------------------------|----------------------|--------------|-------------------------|-------------------------|
| TMUX7201RQXR | ACTIVE | WSON | RQX | 8 | 2500 | RoHS & Green | NIPDAU | Level-1-260C-UNLIM | -40 to 125 | H201 | Samples |
| TMUX7202RQXR | ACTIVE | WSON | RQX | 8 | 2500 | RoHS & Green | NIPDAU | Level-1-260C-UNLIM | -40 to 125 | H202 | Samples |

(1) The marketing status values are defined as follows:

ACTIVE: Product device recommended for new designs.

LIFEBUY: TI has announced that the device will be discontinued, and a lifetime-buy period is in effect.

NRND: Not recommended for new designs. Device is in production to support existing customers, but TI does not recommend using this part in a new design.

PREVIEW: Device has been announced but is not in production. Samples may or may not be available.

OBSOLETE: TI has discontinued the production of the device.

(2) **RoHS:** TI defines "RoHS" to mean semiconductor products that are compliant with the current EU RoHS requirements for all 10 RoHS substances, including the requirement that RoHS substance do not exceed 0.1% by weight in homogeneous materials. Where designed to be soldered at high temperatures, "RoHS" products are suitable for use in specified lead-free processes. TI may reference these types of products as "Pb-Free".

RoHS Exempt: TI defines "RoHS Exempt" to mean products that contain lead but are compliant with EU RoHS pursuant to a specific EU RoHS exemption.

Green: TI defines "Green" to mean the content of Chlorine (Cl) and Bromine (Br) based flame retardants meet JS709B low halogen requirements of <=1000ppm threshold. Antimony trioxide based flame retardants must also meet the <=1000ppm threshold requirement.

(3) MSL, Peak Temp. - The Moisture Sensitivity Level rating according to the JEDEC industry standard classifications, and peak solder temperature.

(4) There may be additional marking, which relates to the logo, the lot trace code information, or the environmental category on the device.

(5) Multiple Device Markings will be inside parentheses. Only one Device Marking contained in parentheses and separated by a "~" will appear on a device. If a line is indented then it is a continuation of the previous line and the two combined represent the entire Device Marking for that device.

(6) Lead finish/Ball material - Orderable Devices may have multiple material finish options. Finish options are separated by a vertical ruled line. Lead finish/Ball material values may wrap to two lines if the finish value exceeds the maximum column width.

Important Information and Disclaimer:The information provided on this page represents TI's knowledge and belief as of the date that it is provided. TI bases its knowledge and belief on information provided by third parties, and makes no representation or warranty as to the accuracy of such information. Efforts are underway to better integrate information from third parties. TI has taken and continues to take reasonable steps to provide representative and accurate information but may not have conducted destructive testing or chemical analysis on incoming materials and chemicals. TI and TI suppliers consider certain information to be proprietary, and thus CAS numbers and other limited information may not be available for release.

In no event shall TI's liability arising out of such information exceed the total purchase price of the TI part(s) at issue in this document sold by TI to Customer on an annual basis.

重要声明和免责声明

TI“按原样”提供技术和可靠性数据（包括数据表）、设计资源（包括参考设计）、应用或其他设计建议、网络工具、安全信息和其他资源，不保证没有瑕疵且不做任何明示或暗示的担保，包括但不限于对适销性、某特定用途方面的适用性或不侵犯任何第三方知识产权的暗示担保。

这些资源可供使用 TI 产品进行设计的熟练开发人员使用。您将自行承担以下全部责任：(1) 针对您的应用选择合适的 TI 产品，(2) 设计、验证并测试您的应用，(3) 确保您的应用满足相应标准以及任何其他功能安全、信息安全、监管或其他要求。

这些资源如有变更，恕不另行通知。TI 授权您仅可将这些资源用于研发本资源所述的 TI 产品的应用。严禁对这些资源进行其他复制或展示。您无权使用任何其他 TI 知识产权或任何第三方知识产权。您应全额赔偿因在这些资源的使用中对 TI 及其代表造成的任何索赔、损害、成本、损失和债务，TI 对此概不负责。

TI 提供的产品受 [TI 的销售条款](#) 或 [ti.com](#) 上其他适用条款/TI 产品随附的其他适用条款的约束。TI 提供这些资源并不会扩展或以其他方式更改 TI 针对 TI 产品发布的适用的担保或担保免责声明。

TI 反对并拒绝您可能提出的任何其他或不同的条款。

邮寄地址：Texas Instruments, Post Office Box 655303, Dallas, Texas 75265

Copyright © 2023，德州仪器 (TI) 公司