

TMUXHS4412 4 通道 20Gbps 差分 2:1/1:2 多路复用器/多路信号分离器

1 特性

- 为四个差分通道提供双向无源 2:1 多路复用器/1:2 多路信号分离器
- 支持高达 20Gbps 的数据速率
- 支持速率高达 16Gbps 的 PCI Express 4.0
- 还支持 USB 3.2、USB 4.0、TBT 3.0、DP 2.0、SATA、SAS、MIPI DSI/CSI、FPD-Link III、LVDS、SFI 和以太网接口
- -3dB 差分带宽为 13GHz
- 出色的 PCIe 4.0 信号动态特性
 - 插入损耗 = -1.3dB (8GHz 时)
 - 回波损耗 = -22dB (8GHz 时)
 - 串扰 = -58dB (8GHz 时)
- 自适应共模电压跟踪
- 支持高达 0V 至 1.8V 的共模电压
- 单电源电压 VCC 为 3.3V 或 1.8V
- 超低有功功耗 (320 μ A) 和待机功耗 (0.1 μ A)
- -40° 至 105°C 的工业温度选项
- [DS160PR421](#) 和 [DS160PR412](#) 的引脚对引脚 PCIe 4.0 线性转接驱动器选项
- 采用 3.5mm x 9mm QFN 封装

2 应用

- [PC 和笔记本电脑](#)
- [游戏、家庭影院与娱乐系统和电视](#)
- [数据中心和企业级计算](#)
- [医疗应用](#)
- [测试和测量](#)
- [工厂自动化和控制](#)
- [航天和国防](#)
- [电子销售终端 \(EPOS\)](#)
- [无线基础设施](#)

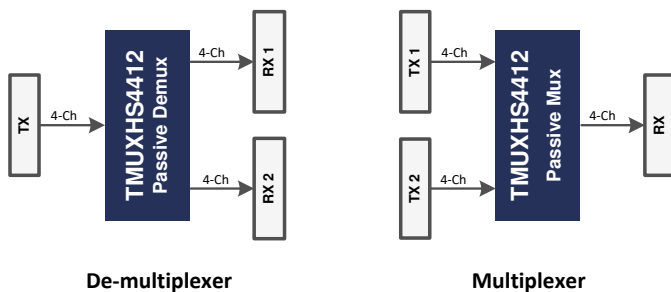

3 说明

TMUXHS4412 是一款高速双向无源开关，可用于多路复用器 (mux) 和多路信号分离器 (Demux) 配置。TMUXHS4412 是一款模拟差分无源多路复用器或多路信号分离器，适用于许多数据速率高达 20Gbps 的高速差分接口，包括 PCI Express 4.0。该器件可用于电气通道具有信号完整性裕量的更高数据速率。TMUXHS4412 支持差分信号，其共模电压范围 (CMV) 高达 0V 至 1.8V，差分振幅高达 1800mVpp。自适应 CMV 跟踪可帮助用户确保通过器件的通道在整个共模电压范围内保持不变。

TMUXHS4412 具有出色的动态特性，从而使信号眼图具有最小的衰减，并且几乎不会增加抖动。该设计中的芯片设计经过优化，可在较高信号频谱上实现出色的频率响应。芯片信号布线和开关网络相匹配，以实现最佳的差分对内延迟差性能。

TMUXHS4412 具有工业级工作温度范围，适合多种严苛应用，包括工业和高可靠性用例。

封装信息 (1)

器件型号	封装	封装大小(2)
TMUXHS4412	RUA (WQFN , 42)	9mm × 3.5mm × 0.5mm 间距
TMUXHS4412I		

(1) 有关所有可用封装，请参阅节 10。

(2) 封装尺寸 (长 × 宽) 为标称值，并包括引脚 (如适用)。

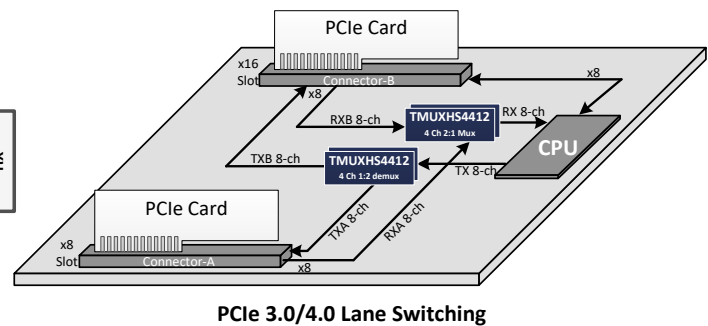

应用用例



Table of Contents

1 特性	1	6.4 Device Functional Modes.....	11
2 应用	1	7 Application and Implementation	12
3 说明	1	7.1 Application Information.....	12
4 Pin Configuration and Functions	3	7.2 Typical Applications.....	13
5 Specifications	5	7.3 Systems Examples.....	17
5.1 Absolute Maximum Ratings.....	5	7.4 Power Supply Recommendations.....	18
5.2 ESD Ratings.....	5	7.5 Layout.....	18
5.3 Recommended Operating Conditions.....	5	8 Device and Documentation Support	20
5.4 Thermal Information.....	5	8.1 Related Documentation.....	20
5.5 Electrical Characteristics.....	6	8.2 接收文档更新通知.....	20
5.6 High-Speed Performance Parameters.....	6	8.3 支持资源.....	20
5.7 Switching Characteristics.....	7	8.4 Trademarks.....	20
5.8 Typical Characteristics.....	8	8.5 静电放电警告.....	20
6 Detailed Description	10	8.6 术语表.....	20
6.1 Overview.....	10	9 Revision History	20
6.2 Functional Block Diagram.....	10	10 Mechanical, Packaging, and Orderable Information	20
6.3 Feature Description.....	11		

4 Pin Configuration and Functions



图 4-1. RUA Package 42-Pin WQFN Top View

表 4-1. Pin Functions

PIN		TYPE	DESCRIPTION
NAME	NO.		
D0P	3	I/O	Common Port (D), channel 0, high-speed positive signal
D0N	4	I/O	Common Port, channel 0, high-speed negative signal
D1P	7	I/O	Common Port, channel 1, high-speed positive signal
D1N	8	I/O	Common Port, channel 1, high-speed negative signal
D2P	10	I/O	Common Port, channel 2, high-speed positive signal
D2N	11	I/O	Common Port, channel 2, high-speed negative signal
D3P	14	I/O	Common Port, channel 3, high-speed positive signal
D3N	15	I/O	Common Port, channel 3, high-speed negative signal
DA0P	38	I/O	Port A (DA), channel 0, high-speed positive signal
DA0N	37	I/O	Port A, channel 0, high-speed negative signal
DA1P	34	I/O	Port A, channel 1, high-speed positive signal
DA1N	33	I/O	Port A, channel 1, high-speed negative signal
DA2P	29	I/O	Port A, channel 2, high-speed positive signal

表 4-1. Pin Functions (续)

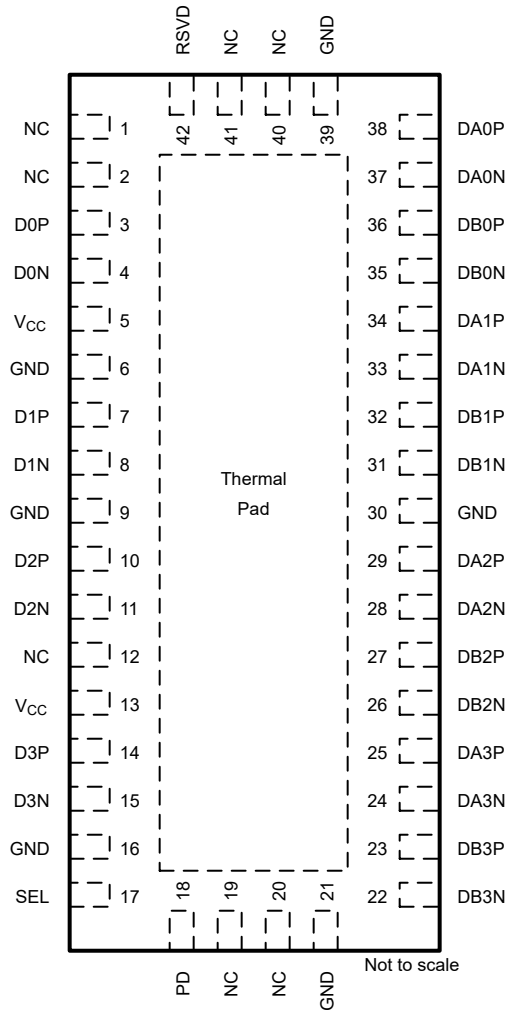
PIN		TYPE	DESCRIPTION
NAME	NO.		
DA2N	28	I/O	Port A, channel 2, high-speed negative signal
DA3P	25	I/O	Port A, channel 3, high-speed positive signal
DA3N	24	I/O	Port A, channel 3, high-speed negative signal
DB0P	36	I/O	Port B (DB), channel 0, high-speed positive signal
DB0N	35	I/O	Port B, channel 0, high-speed negative signal
DB1P	32	I/O	Port B, channel 1, high-speed positive signal
DB1N	31	I/O	Port B, channel 1, high-speed negative signal
DB2P	27	I/O	Port B, channel 2, high-speed positive signal
DB2N	26	I/O	Port B, channel 2, high-speed negative signal
DB3P	23	I/O	Port B, channel 3, high-speed positive signal
DB3N	22	I/O	Port B, channel 3, high-speed negative signal
GND	6, 9, 16, 21,30, 39	G	Ground
PD	18	I	Active-low chip enable. H: Shutdown
NC	1, 2, 12, 19, 20, 40, 41	NA	Leave unconnected
RSVD	42	NA	Reserved - TI test mode. Pulldown to GND using a resistor such as 4.7k Ω
SEL	17	I	Port select pin. L: Common Port (D) to Port A (DA) H: Common Port (D) to Port B (DB)
V _{CC}	5, 13	P	3.3 or 1.8V power

5 Specifications

5.1 Absolute Maximum Ratings

over operating free-air temperature range (unless otherwise noted)⁽¹⁾

		MIN	MAX	UNIT	
V _{CC-ABS} MAX	Supply voltage	- 0.5	4	V	
V _{HS-ABS} MAX	Voltage	Differential I/O pins	- 0.5	2.4	V
V _{CTR-ABS} MAX	Voltage	Control pins	- 0.5	V _{CC} +0.4	V
T _{STG}	Storage temperature	- 65	150	°C	

- (1) Stresses beyond those listed under *Absolute Maximum Ratings* may cause permanent damage to the device. These are stress ratings only, which do not imply functional operation of the device at these or any other conditions beyond those indicated under *Recommended Operating Conditions*. Exposure to absolute-maximum-rated conditions for extended periods may affect device reliability.

5.2 ESD Ratings

			VALUE	UNIT
V _{ESD}	Electrostatic discharge	Human-body model (HBM), per ANSI/ESDA/JEDEC JS-001 ⁽¹⁾	±2000	V
		Charged-device model (CDM), per JEDEC specification JESD22-C101 ⁽²⁾	±1000	

- (1) JEDEC document JEP155 states that 500-V HBM allows safe manufacturing with a standard ESD control process.
 (2) JEDEC document JEP157 states that 250-V CDM allows safe manufacturing with a standard ESD control process.

5.3 Recommended Operating Conditions

over operating free-air temperature range (unless otherwise noted)

		MIN	TYP	MAX	UNIT	
V _{CC}	Supply voltage	1.8 V supply voltage mode	1.71	1.8	1.98	V
		3.3 V supply voltage mode	3.0	3.3	3.6	V
V _{CC-RAMP}	Supply voltage ramp time	0.1		100	ms	
V _{IH}	Input high voltage	SEL, PD pins	0.75V _{CC}		V	
V _{IL}	Input low voltage	SEL, PD pins		0.25V _{CC}	V	
V _{DIFF}	High-speed signal pins differential voltage	0		1.8	V _{pp}	
V _{CM}	High speed signal pins common mode voltage	1.8 V supply voltage mode, biased from common port (D)	0	0.9	V	
		3.3 V supply voltage mode, biased from D or DA/DB ports.	0	1.8	V	
T _A	Operating free-air/ambient temperature	TMUXHS4412	0	70	°C	
		TMUXHS4412I	-40	105	°C	

5.4 Thermal Information

THERMAL METRIC ⁽¹⁾		TMUXHS4412	UNIT
		RUA (WQFN)	
		42 PINS	
R _{θJA}	Junction-to-ambient thermal resistance - High K	32.6	°C/W
R _{θJC(top)}	Junction-to-case (top) thermal resistance	21.8	°C/W
R _{θJB}	Junction-to-board thermal resistance	14.4	°C/W
ψ _{JT}	Junction-to-top characterization parameter	1.4	°C/W
ψ _{JB}	Junction-to-board characterization parameter	14.3	°C/W
R _{θJC(bot)}	Junction-to-case (bottom) thermal resistance	7.8	°C/W

- (1) For more information about traditional and new thermalmetrics, see the [Semiconductor and IC Package ThermalMetrics](#) application report.

5.5 Electrical Characteristics

over operating free-air temperature and supply voltage range (unless otherwise noted)

PARAMETER		TEST CONDITIONS	MIN	TYP	MAX	UNIT
I _{CC}	Device active current	PD = 0; 0 V ≤ V _{CM} ≤ 1.8; SEL = 0 or V _{CC}		320	480	μA
I _{STDN}	Device shutdown current	PD = V _{CC}		0.1	2	μA
C _{ON}	Output ON capacitance to GND	PD = 0; f = 8 GHz		0.45		pF
R _{ON}	Output ON resistance	0 V ≤ V _{CM} ≤ 1.8 V; I _O = - 8 mA		5	8	Ω
I _{IH,CTRL}	Input high current, control pins (SEL, PD)	V _{IN} = 3.6 V			2	μA
I _{IL,CTRL}	Input low current, control pins (SEL, PD)	V _{IN} = 0 V			1	μA
R _{CM,HS}	Common mode resistance to ground on D pins (Dx[P/N])	Each pin to GND		1.0	1.4	MΩ
I _{IH,HS,SEL}	Input high current, high-speed pins [Dx/DAx/DBx] [P/N]	V _{IN} = 1.8 V for selected port, D and DA pins with SEL = 0, and D and DB pins with SEL = V _{CC}			5	μA
I _{IH,HS,NSEL}	Input high current, high-speed pins [Dx/DAx/DBx] [P/N]	V _{IN} = 1.8 V for non-selected port, DB with SEL = 0, and DA with SEL = V _{CC} ⁽¹⁾			150	μA
I _{HIZ,HS}	Leakage current through turned off switch between Dx[P/N] and [DA/DB]x[P/N]	PD = V _{CC} ; Dx[P/N] = 1.8 V, [DA/DB]x[P/N] = 0 V and Dx[P/N] = 0 V, [DA/DB]x[P/N] = 1.8 V			4	μA
R _{A,p2n}	DC Impedance between Dx[P] and Dx[N] pins	PD = 0 and V _{CC}		20		KΩ

(1) There is a 20-kΩ pull-down in non-selected port.

5.6 High-Speed Performance Parameters

PARAMETER	TEST CONDITION	MIN	TYP	MAX	UNIT
I _L	Differential insertion loss	f = 10 MHz	-0.4		dB
		f = 2.5 GHz	-0.7		
		f = 4 GHz	-0.8		
		f = 5 GHz	-0.9		
		f = 8 GHz	-1.3		
		f = 10 GHz	-1.8		
BW	- 3-dB bandwidth		13		GHz
R _L	Differential return loss	f = 10 MHz	-30		dB
		f = 2.5 GHz	-23		
		f = 4 GHz	-23		
		f = 5 GHz	-22		
		f = 8 GHz	-22		
		f = 10 GHz	-15		
O _{IRR}	Differential OFF isolation	f = 10 MHz	-57		dB
		f = 2.5 GHz	-27		
		f = 4 GHz	-22		
		f = 5 GHz	-20		
		f = 8 GHz	-15		
		f = 10 GHz	-12		
X _{TALK}	Differential crosstalk	f = 10 MHz	-73		dB
		f = 2.5 GHz	-64		
		f = 4 GHz	-61		
		f = 5 GHz	-61		
		f = 8 GHz	-58		
		f = 10 GHz	-54		
SCD11,22	Mode conversion - differential to common mode	f = 8 GHz	-29		dB

PARAMETER		TEST CONDITION	MIN	TYP	MAX	UNIT
SCD21,12	Mode conversion - differential to common mode	$f = 8 \text{ GHz}$		-25		dB
SDC11,22	Mode conversion - common mode to differential	$f = 8 \text{ GHz}$		-29		dB
SDC21,12	Mode conversion - common mode to differential	$f = 8 \text{ GHz}$		-25		dB

5.7 Switching Characteristics

PARAMETER			MIN	TYP	MAX	UNIT
t_{PD}	Switch propagation delay	$f = 1 \text{ Ghz}$		50		ps
t_{SW_ON}	Switching time SEL-to-Switch ON	Biased from DA/DB side with CMV difference is <100mV, DA/DB pins at 90% of final value			130	ns
t_{SW_OFF}	Switching time SEL-to-Switch OFF	Biased from DA/DB side with CMV difference is <100mV, DA/DB pins at 90% of final value			100	ns
t_{SK_INTRA}	Intra-pair output skew between P and N pins for same channel	$f = 1 \text{ Ghz}$		4.0		ps
t_{SK_INTER}	Inter-pair output skew between channels	$f = 1 \text{ Ghz}$		4.0		ps

5.8 Typical Characteristics

The following figures show differential insertion loss on the top plot and return loss on the bottom plot of a typical TMUXHS4412 channel. Note measurements are performed in TI evaluation board with board and equipment parasitics calibrated out.



图 5-1. S-Parameter Plots for a TMUXHS4412 Channel: Differential Insertion Loss



图 5-2. S-Parameter Plots for a TMUXHS4412 Channel: Return Loss vs Frequency

The following figures show side-by-side comparisons of 10Gbps signals through calibration traces and a typical TMUXHS4412 channels.

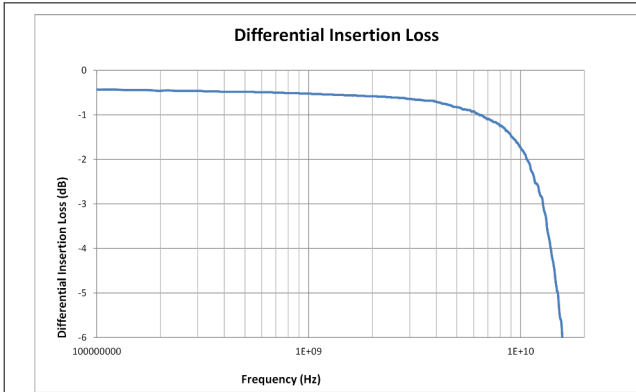

图 5-3. Jitter Decomposition of 10Gbps PRBS-7 Signals in TI Evaluation Board Through Calibration Traces

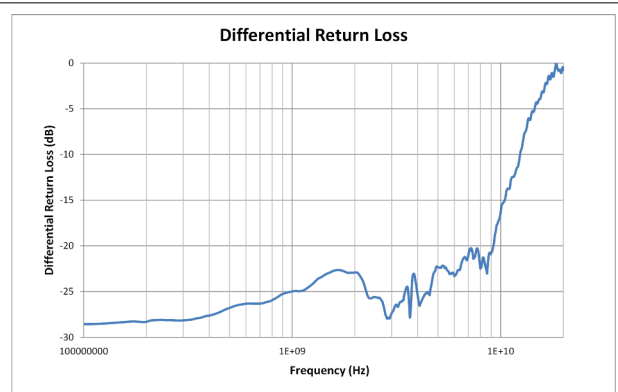

图 5-4. Jitter Decomposition of 10Gbps PRBS-7 Signals in TI Evaluation Board Through a Typical TMUXHS4412 Channel

The following figures show side-by-side comparisons of 20Gbps signals through calibration traces and a typical TMUXHS4412 channels.

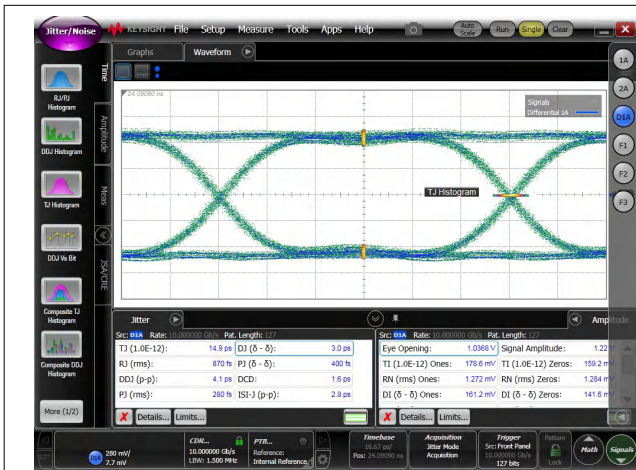

图 5-5. Jitter Decomposition of 20Gbps PRBS-7 Signals in TI Evaluation Board Through Calibration Traces

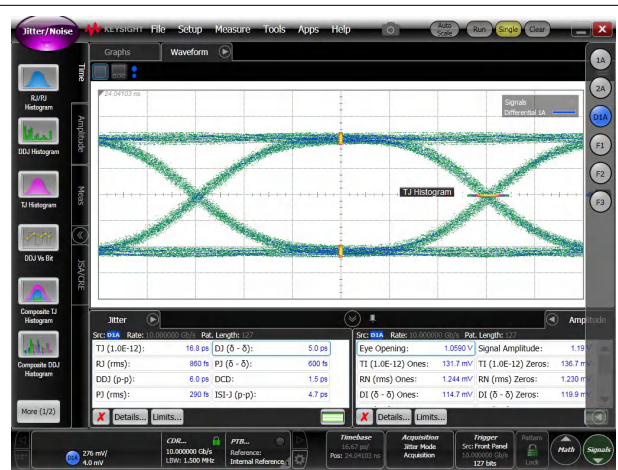

图 5-6. Jitter Decomposition of 20Gbps PRBS-7 Signals in TI Evaluation Board Through a Typical TMUXHS4412 Channels

6 Detailed Description

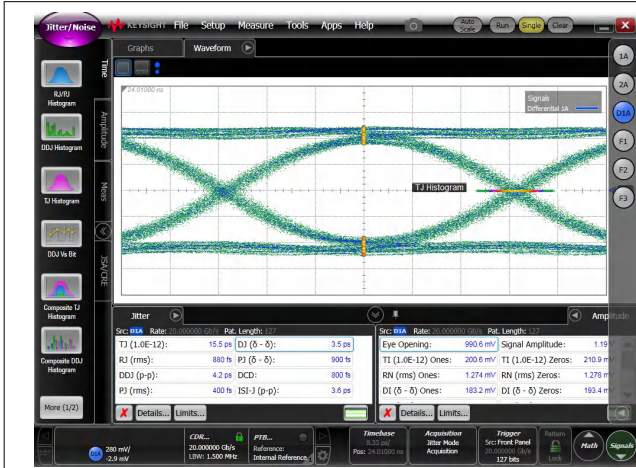
6.1 Overview

The TMUXHS4412 is an analog passive mux/demux that can work for any high-speed interface as long as the signaling is differential, has a common-mode voltage (CMV) that is within valid range (0V to 1.8V for 3.3V supply voltage mode), and has amplitude up to 1800mVpp-differential. The device has adaptive input voltage tracking to help users ensure the channel remains unchanged for the entire common-mode voltage range. Two channels of the device can be used for electrical signals that have different CMV between them. Two channels can also be used in such a way that the device switches two different interface signals with different data and electrical characteristics.

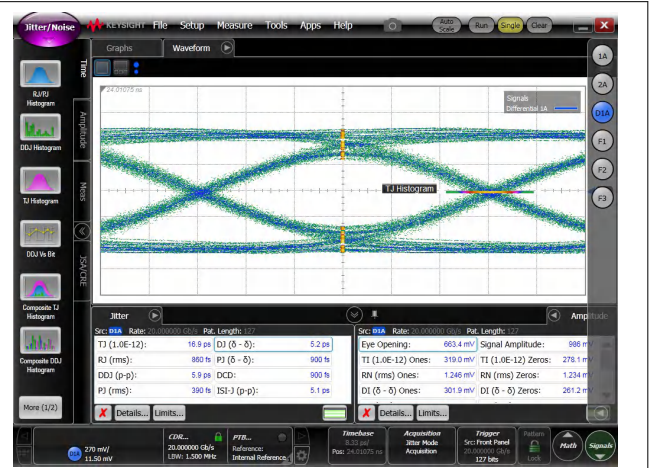
Excellent dynamic characteristics of the device allow high speed switching with minimum attenuation to the signal eye diagram with very little added jitter. While the device is recommended for the interfaces up to 20Gbps, actual data rate where the device can be used highly depends on the electrical channels. For low loss channels where adequate margin is maintained the device can potentially be used for higher data rates.

The TMUXHS4412 is only recommended for differential signaling. If the two signals on differential lines are completely uncorrelated, then internal circuits can create certain artifacts. TI recommends to analyze the data line biasing of the device for such single-ended use cases. The device parameters are characterized for differential signaling only.

6.2 Functional Block Diagram

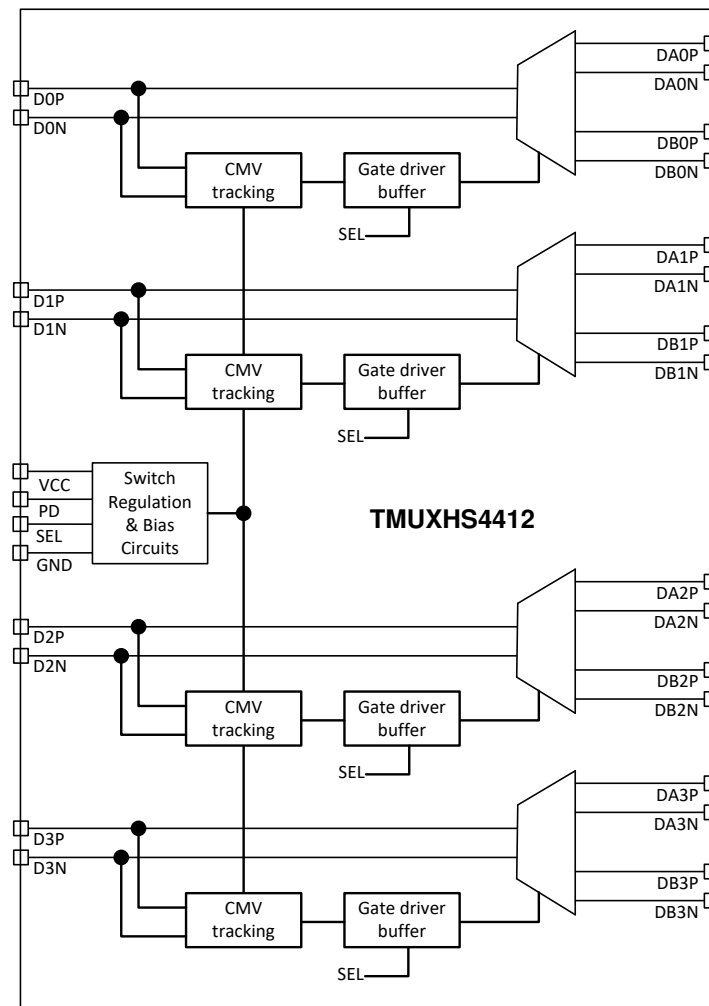

6.3 Feature Description

6.3.1 Output Enable and Power Savings

The TMUXHS4412 has two power modes, active/normal operating mode and standby/shutdown mode. During standby mode, the device consumes very little current to achieve ultra-low power in systems where power saving is critical. To enter standby mode, the PD control pin is pulled high through a resistor and must remain high. For active/normal operation, pull the PD control pin low to GND or dynamically controlled to switch between H or L.

6.3.2 Data Line Biasing

The TMUXHS4412 has a weak pulldown of $1M\ \Omega$ from D[0/1/2/3][P/N] pins to GND. While these resistors biases the device data channels to common-mode voltage (CMV) of 0V with very weak strength, TI recommends that the device is biased by a stronger impedance from either side of the device to a valid value. To avoid double biasing, ensure appropriate AC coupling capacitors are on either side of the device.

In certain use cases where both sides of the TMUXHS4412 is AC-coupled, TI recommends to use appropriate CMV biasing for the device. $10k\ \Omega$ to GND or any other bias voltage in the CMV range for each D[0/1/2/3][P/N] pin will suffice for most use cases.

The high-speed data ports incorporate $20k\ \Omega$ pulldown resistors that are switched in when a port is not selected and switched out when the port is selected. For example: when SEL = L, the DB[0/1/2/3][P/N] pins have $20k\ \Omega$ resistors to GND. The feature ensures that unselected port is always biased to a known voltage for long term reliability of the device and the electrical channel.

The positive and negative terminals of data pins D[0/1/2/3] have a weak ($20k\ \Omega$) differential resistor in between the terminals for device switch regulation operation. This does not impact signal integrity or functionality of high-speed differential signaling that typically has much stronger differential impedance (such as $100\ \Omega$).

6.4 Device Functional Modes

表 6-1. Port Select Control Logic ⁽¹⁾

PORT D CHANNEL	PORT DA OR PORT DB CHANNEL CONNECTED TO PORT D CHANNEL	
	SEL = L	SEL = H
D0P	DA0P	DB0P
D0N	DA0N	DB0N
D1P	DA1P	DB1P
D1N	DA1N	DB1N
D2P	DA2P	DB2P
D2N	DA2N	DB2N
D3P	DA3P	DB3P
D3N	DA3N	DB3N

- (1) The TMUXHS4412 can tolerate polarity inversions for all differential signals on Ports D, DA, and DB. In such flexible implementation, users must ensure that the same polarity is maintained on Port D versus Ports DA/DB.

7 Application and Implementation

备注

Information in the following applications sections is not part of the TI component specification, and TI does not warrant its accuracy or completeness. TI's customers are responsible for determining suitability of components for their purposes. Customers should validate and test their design implementation to confirm system functionality.

7.1 Application Information

The TMUXHS4412 is an analog 4-channel high-speed mux/demux type of switch that can be used for routing high-speed signals between two different locations on a circuit board. The TMUXHS4412 can be used for many high-speed interfaces including:

- Peripheral Component Interconnect Express (PCIe) Gen 1.0, 2.0, 3.0, 4.0
- USB 4.0
- Universal Serial Bus (USB) 3.2 Gen 1.0, 2.0
- Serial ATA (SATA/eSATA)
- Serial Attached SCSI (SAS)
- Display Port (DP) 1.4, 2.0
- Thunderbolt (TBT) 3.0
- MIPI Camera Serial Interface (CSI-2), Display Serial Interface (DSI)
- Low Voltage Differential Signaling (LVDS)
- Serdes Framer Interface (SFI)
- Ethernet Interfaces

The mux/demux selection pin SEL can easily be controlled by an available GPIO pin of a controller or hard tie to voltage level H or L as an application requires.

The TMUXHS4412 with adaptive voltage tracking technology can support applications where the common mode is different between the RX and TX pair. The switch paths of the TMUXHS4412 have internal weak pulldown resistors of $1M\Omega$ on the common port pins. While these resistors biases the device data channels to common-mode voltage (CMV) of 0V with a weak strength, TI recommends to bias the device from either side of the device to a valid value (in the range of 0V to 1.8V in 3.3V supply voltage mode). It is expected that the system/host controller and device/end point common-mode bias impedances are much stronger (smaller) than the TMUXHS4412 internal pulldown resistors and are therefore not impacted.

Many interfaces require AC coupling between the transmitter and receiver. The 0201 or 0402 capacitors are the preferred option to provide AC coupling. Avoid the 0603, 0805 size capacitors and C-packs. When placing AC-coupling capacitors, symmetric placement is best. The capacitor value must be chosen according to the specific interface the device is being used. Make sure the value of the capacitor matches the positive and negative signal pair. For many interfaces such as USB 3.2 and PCIe, the designer can place them along the TX pairs on the system board, which are usually routed on the top layer of the board. Use the appropriate value for AC-coupling capacitors based on the application and interface specifications.

The AC-coupling capacitors have several placement options. Typical use cases warrant that the capacitors are placed on one side of the TMUXHS4412. In certain use cases, if both sides of the TMUXHS4412 is AC-coupled, TI recommends to use appropriate CMV biasing for the device. $10k\Omega$ to GND or any other bias voltage in the valid CMV range for each D[0/1/2/3][P/N] pin of the common port suffice for most use cases. [图 7-1](#) shows a few placement options. Note for brevity not all channels are illustrated in the block diagrams. Some interfaces such as USB SS and PCIe recommend placing AC-coupling capacitors on the TX signals before a connector. Option (a) features TX AC-coupling capacitors on the connector side of the TMUXHS4412. Option (b) illustrates the capacitors on the host of the TMUXHS4412. Option (c) showcases where the TMUXHS4412 is AC-coupled on both sides. VBIAS must be within the valid CMV of the device.



图 7-1. AC-Coupling Capacitors Placement Options Between Host and Device / Endpoint

7.2 Typical Applications

7.2.1 PCIe Lane Muxing

The TMUXHS4412 can be used to switch PCIe lanes between two slots. In many PC and server motherboards, the CPU does not have enough PCIe lanes to provide desired system flexibility for end customers. In such applications, the TMUXHS4412 can be used to switch PCIe TX and RX lanes between two slots. 图 7-2 provides a schematic where four TMUXHS4412 are used to switch eight PCIe lanes (8-TX and 8-RX channels). Note the common-mode voltage (CMV) bias for the TMUXHS4412 must be within the valid range. In implementations where receiver CMV bias of a PCIe root complex or an end point can not be ensured within the CMV range, additional DC-blocking capacitors and appropriate CMV biasing must be implemented. One side of the device has AC-coupling capacitors. Additionally the PD pin must be low for device to work. This pin can be driven by a processor.

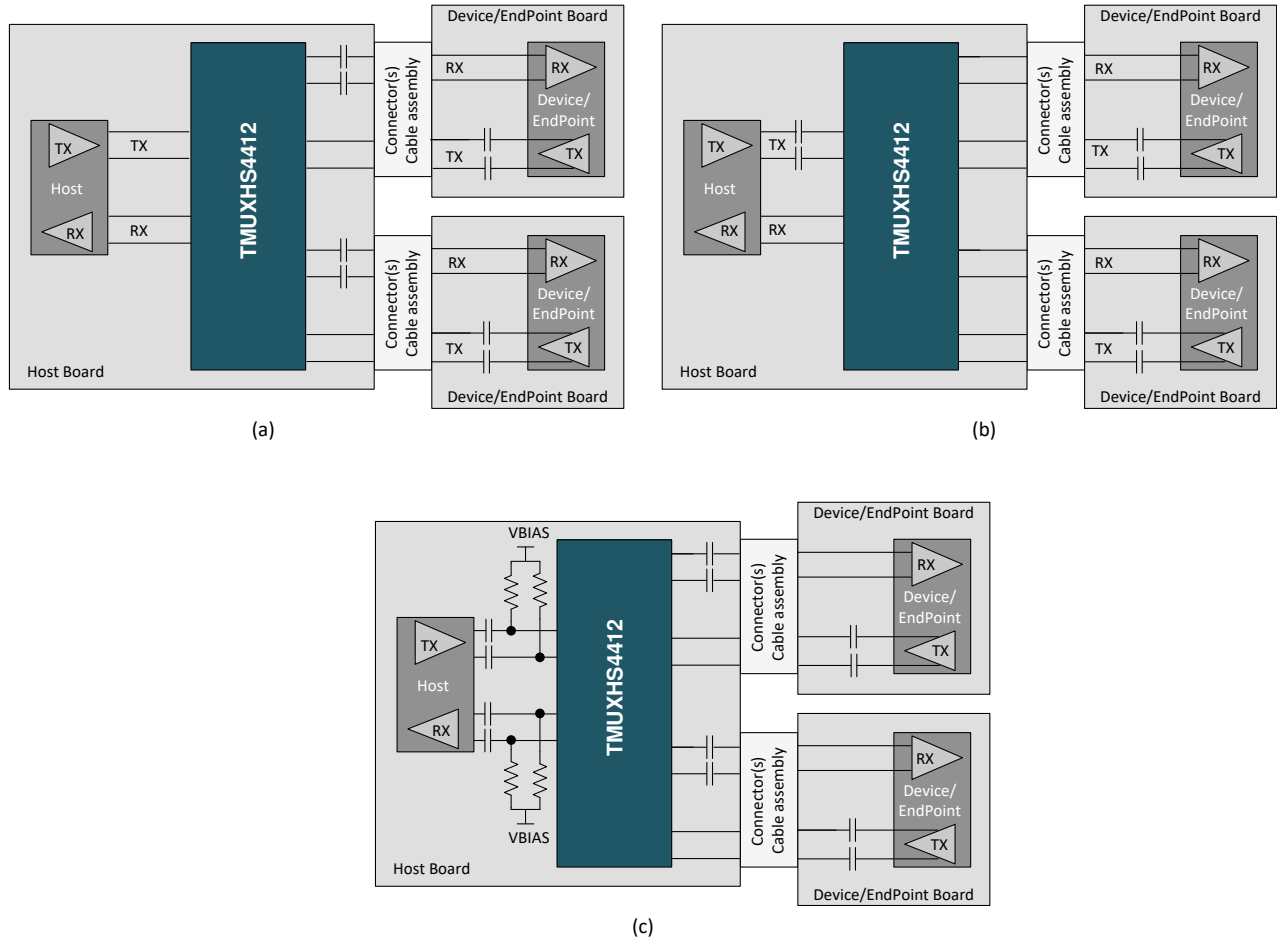

图 7-2. PCIe Lane Muxing

7.2.1.1 Design Requirements

表 7-1 provides various parameters and the expected values to implement the PCIe lane switching topology. Note the recommendation is for illustration purpose only.

表 7-1. Design Parameters

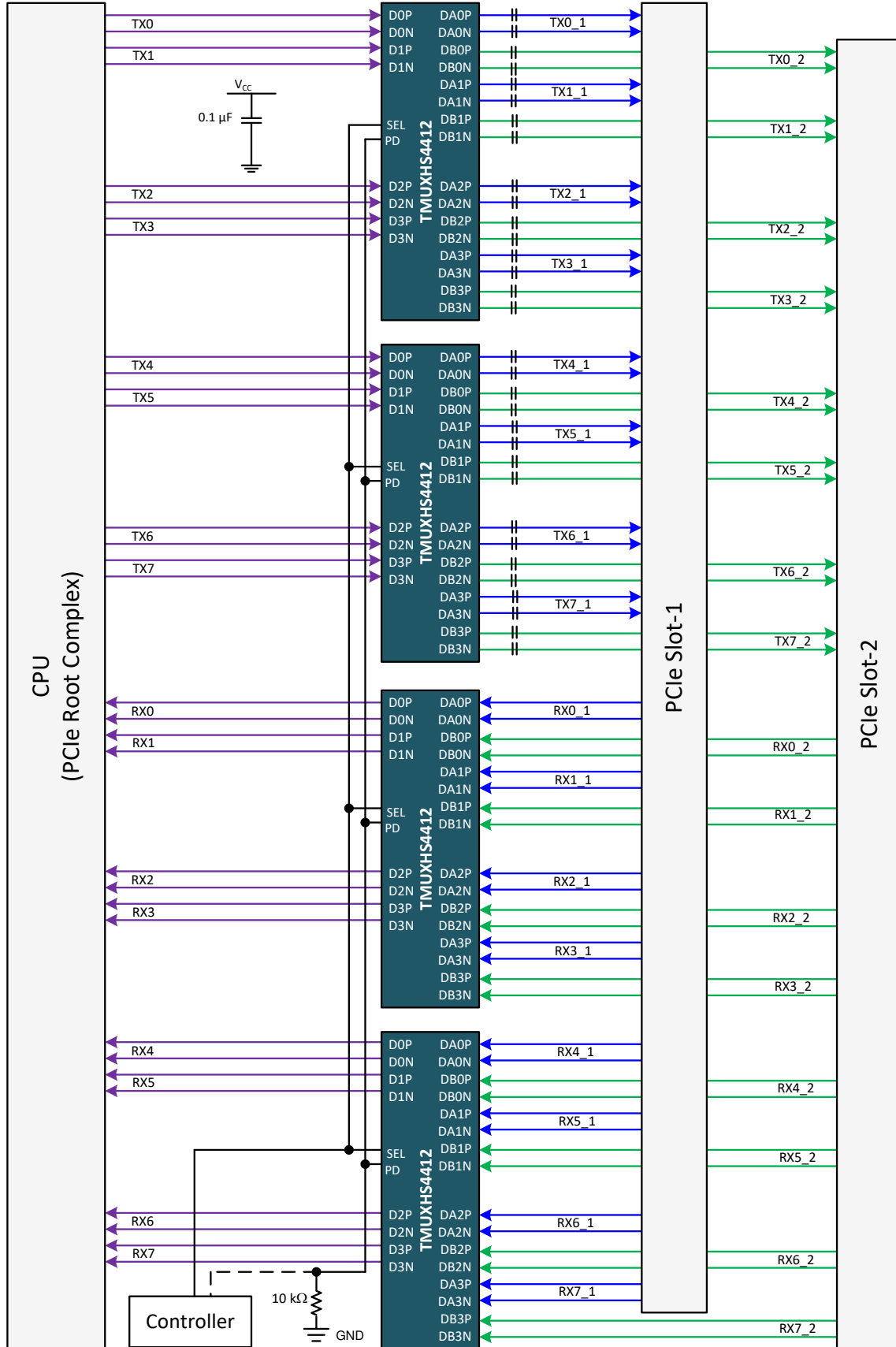
DESIGN PARAMETER	VALUE (V _{CC} = 3.3V)	VALUE (V _{CC} = 1.8V)
Dx[P/N], DAx[P/N], DBx[P/N] CM input voltage	0V to 1.8V	0V to 0.9V Must be biased from Dx[P/N] side)
SEL/PD pin max voltage for low	<0.25 × V _{CC}	
SEL/PD pin min voltage for high	>0.75 × V _{CC}	
AC coupling capacitor for PCIe TX pins	75nF to 265nF	
Decoupling capacitor for V _{CC}	0.1μF	

7.2.1.2 Detailed Design Procedure

The TMUXHS4412 is a high-speed passive switch device that can behave as a mux or demux. The TMUXHS4412 is a passive switch that provides no signal conditioning capability, therefore signal integrity is important. To implement PCIe lane switching topology, the designer must understand the following.

- Determine the loss profile between circuits that are to be muxed or demuxed.
- Provide clean impedance and electrical length matched board traces.
- Provide a control signal for the SEL and PD pins.
- The thermal pad must be connected to ground.
- See the application schematics on recommended decouple capacitors from V_{CC} pins to ground.

7.2.1.3 Pin-to-Pin Passive Versus Redriver Option

For 8-lane PCIe lane muxing application a topology with four TMUXHS4412 devices is illustrated. TMUXHS4412 is a passive mux/demux component that does not provide any signal conditioning. If a specific board implementation has too much loss from CPU to PCIe CEM connectors, a signal conditioning device such as linear redriver may be required for best fidelity of the PCIe link. DS160PR421 is a PCIe 4.0 linear redriver with integrated mux and DS160PR412 is a PCIe 4.0 linear redriver with integrated demux. Both of these devices are pin-to-pin (p2p) compatible with the TMUXHS4412, which allows an easy transition if signal conditioning function is needed to extend the PCIe link reach. 图 7-3 illustrates p2p passive versus redriver option to implement PCIe lane switching.



图 7-3. Pin-to-Pin Passive vs Redriver Option for PCIe Lane Switching

TMUXHS4412

ZHCSN19A – DECEMBER 2020 – REVISED OCTOBER 2024

7.2.1.4 Application Curves

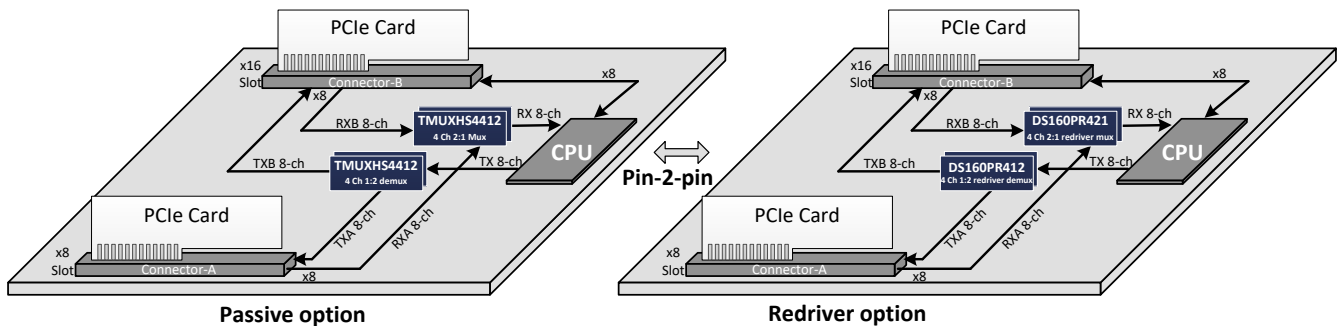
The following figures show the eye diagrams for PRBS-7 signals through calibration trace and TMUXHS4412 for PCIe 3.0 (8Gbps) and PCIe 4.0 (16Gbps), respectively.



图 7-4. 8Gbps PRBS-7 Signals in TI Evaluation Board Through Calibration Traces



图 7-5. 8Gbps PRBS-7 Signals in TI Evaluation Board Through a Typical TMUXHS4412 Channel

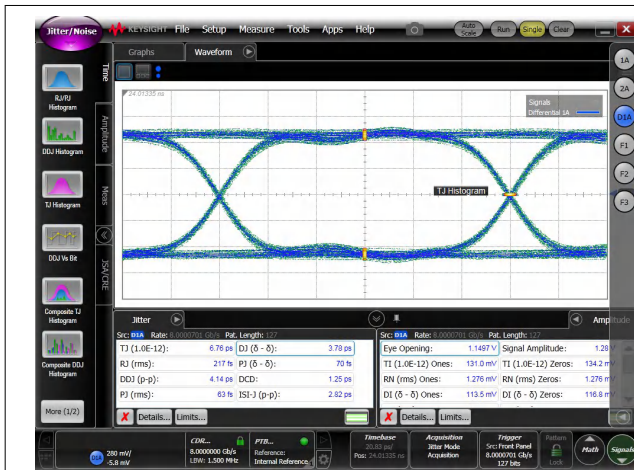

图 7-6. 16Gbps PRBS-7 Signals in TI Evaluation Board Through Calibration Traces

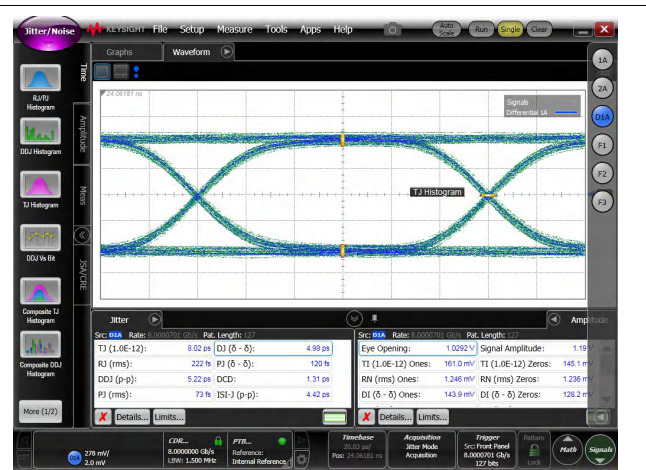

图 7-7. 16Gbps PRBS-7 Signals in TI Evaluation Board Through a Typical TMUXHS4412 Channel

7.3 Systems Examples

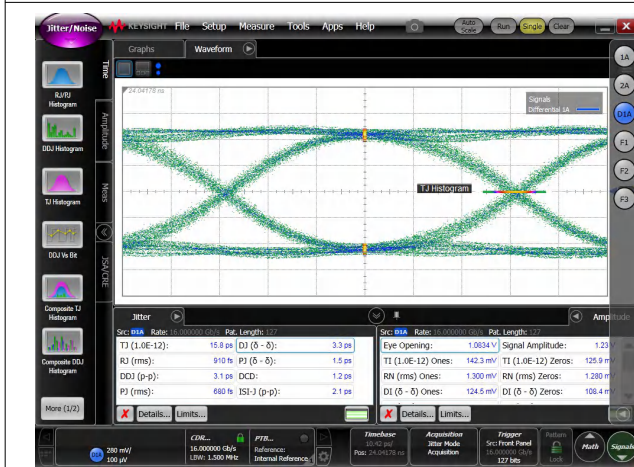
7.3.1 PCIe Muxing for Hybrid SSD

图 7-8 illustrate a use case where a hybrid SSD is shared by CPU and an IO expander (PCH).

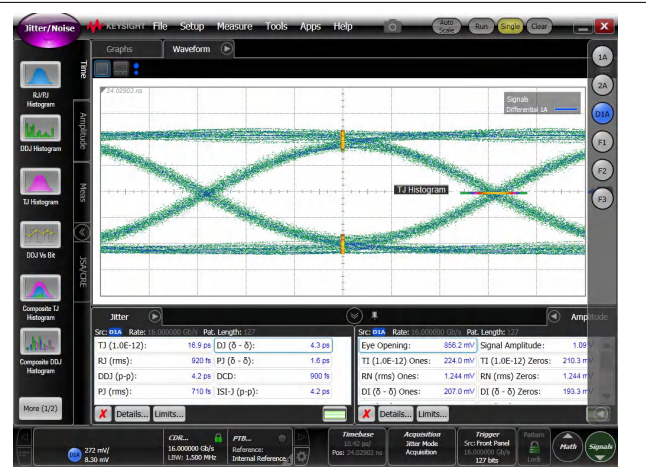

图 7-8. PCIe Muxing to M.2 Connectivity for Hybrid SSD

7.3.2 DisplayPort Main Link

图 7-9 shows an application block diagram to implement DisplayPort (DP) main link switch either in mux or demux configuration. Note DP link also has sideband signals such as Auxiliary (AUX) and Hot Plug Detect (HPD) which must be switched outside of this device.

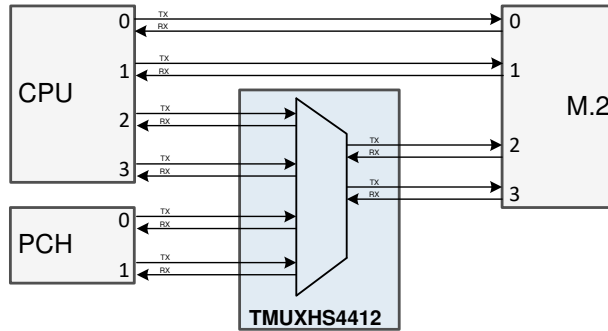

图 7-9. DisplayPort Main Link Demuxing/Muxing

7.3.3 USB 4.0 / TBT 3.0 Demuxing

图 7-10 shows an application block diagram where TMUXHS4412 is used to demultiplex USB 4.0 / TBT 3.0 TX and RX signals. Note SBU signals within USB-C interface must be switched outside of this device.

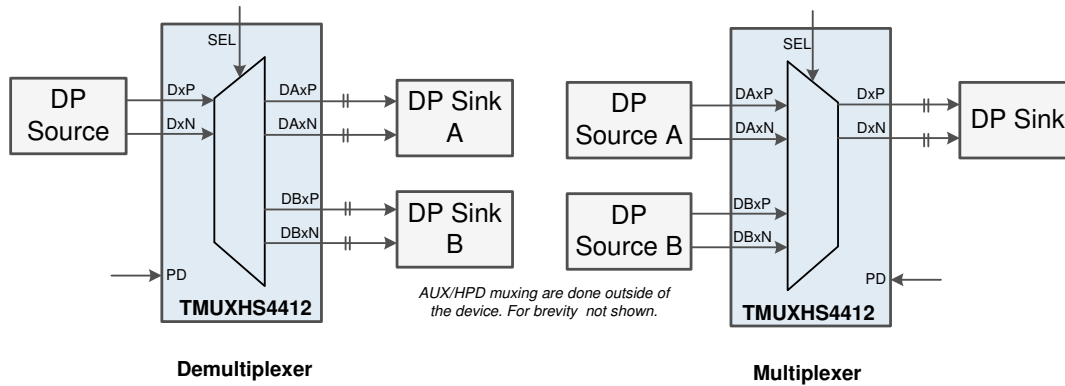

图 7-10. USB 4.0 / TBT 3.0 Demuxing

7.4 Power Supply Recommendations

The TMUXHS4412 does not require a power supply sequence. However, TI recommends that PD is asserted low after device supply V_{CC} is stable and in specification. TI also recommends to place ample decoupling capacitors at the device V_{CC} near the pin.

7.5 Layout

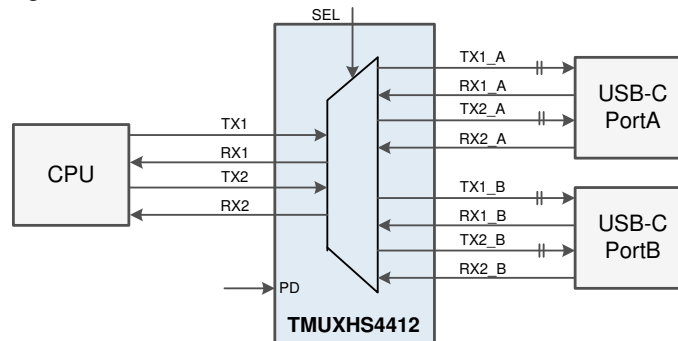
7.5.1 Layout Guidelines

On a high-K board, TI always recommends to solder the PowerPAD™ integrated circuit package onto the thermal land. A thermal land is the area of solder-tinned-copper underneath the PowerPAD integrated circuit package. On a high-K board, the TMUXHS4412 can operate over the full temperature range by soldering the Power-pad onto the thermal land without vias.

For high speed layout guidelines refer to the [High-Speed Layout Guidelines for Signal Conditioners and USB Hubs application note](#).

On a low-K board, for the device to operate across the temperature range, the designer must use a 1oz Cu trace connecting the GND pins to the thermal land. A general PCB design guide for PowerPAD integrated circuit packages is provided in [PowerPAD™ Thermally Enhanced Package application note](#).

7.5.2 Layout Example

图 7-11 shows TMUXHS4412 layout example.



图 7-11. TMUXHS4412 Layout Example

图 7-12 shows a layout illustration here four TMUXHS4412 is used to switch eight PCIe lanes between two PCIe connectors.

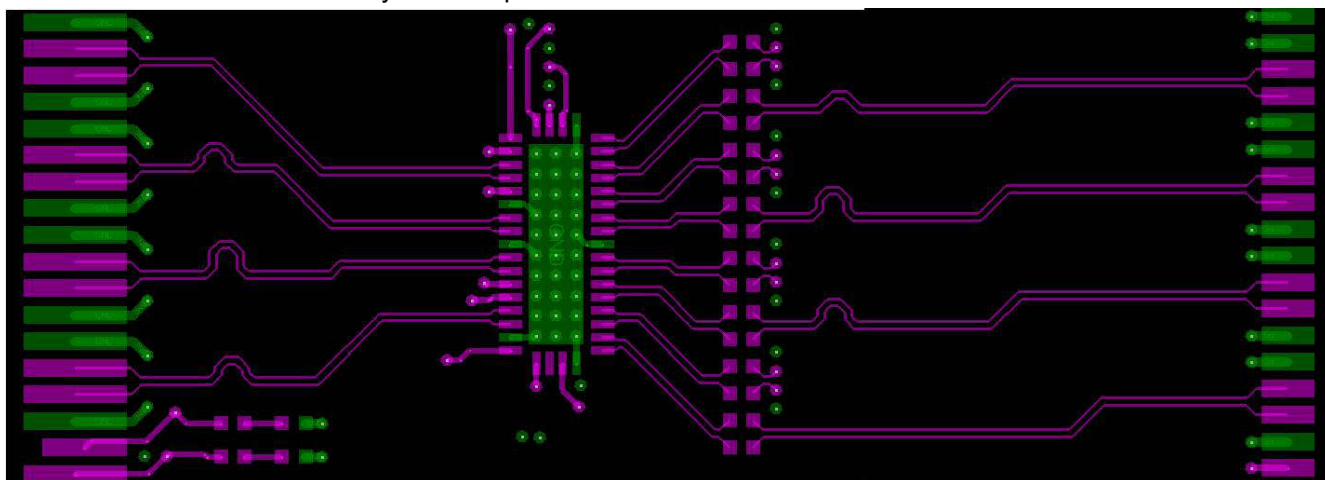

图 7-12. Layout Example for PCIe Lane Muxing Application

8 Device and Documentation Support

8.1 Related Documentation

8.1.1 Documentation Support

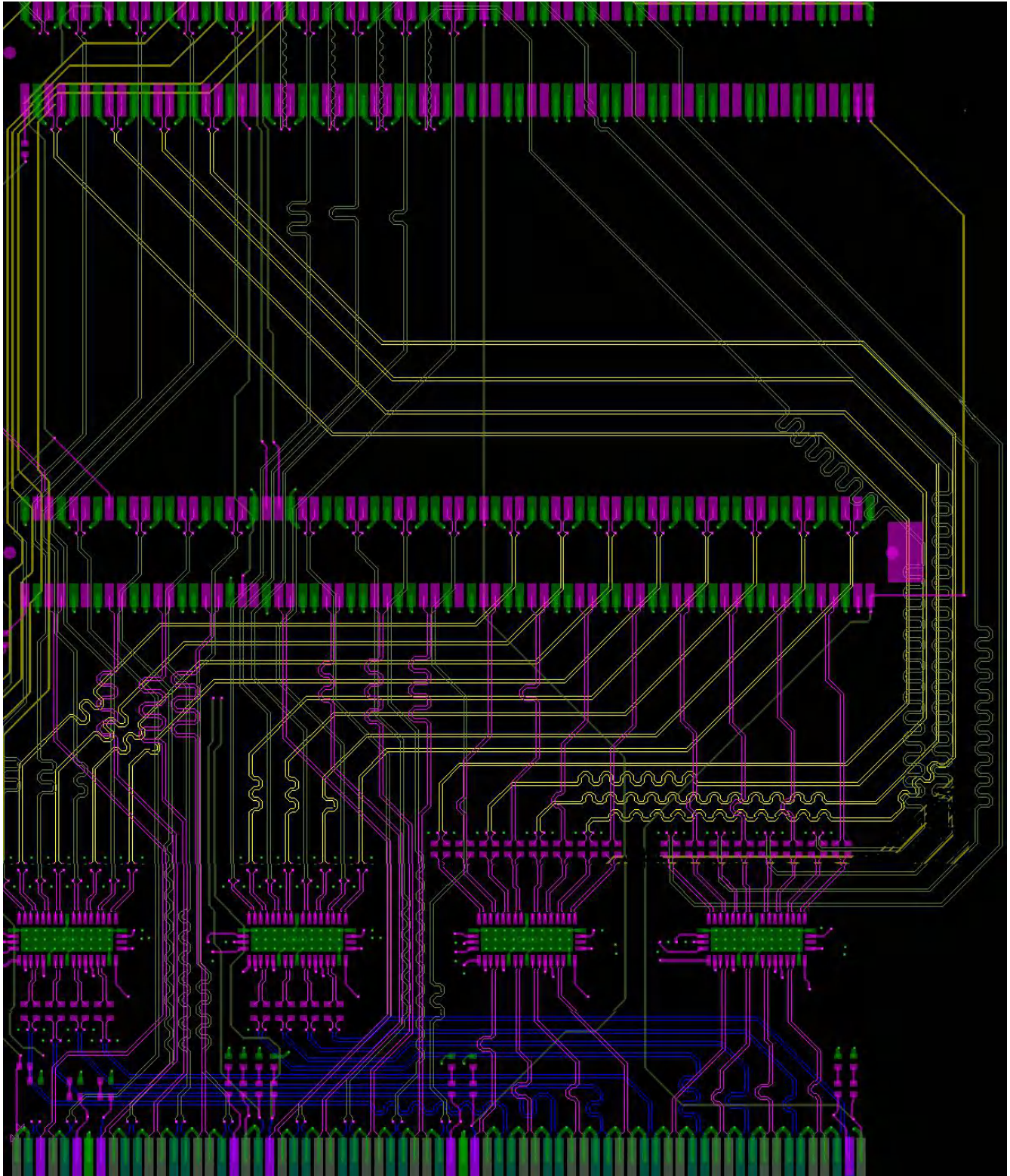
For related documentation, see the following:

- Texas Instruments, [DS160PR412 PCIe® 4.0 16Gbps 4-Channel Linear Redriver with Integrated 1:2 Demux data sheet](#)
- Texas Instruments, [DS160PR421 PCIe® 4.0 16Gbps 4-Channel Linear Redriver with Integrated 2:1 Mux data sheet](#)
- Texas Instruments, [High-Speed Layout Guidelines for Signal Conditioners and USB Hubs application note](#)
- Texas Instruments, [PowerPAD™ Thermally Enhanced Package application note](#)

8.2 接收文档更新通知

要接收文档更新通知，请导航至 [ti.com](https://www.ti.com) 上的器件产品文件夹。点击 [通知](#) 进行注册，即可每周接收产品信息更改摘要。有关更改的详细信息，请查看任何已修订文档中包含的修订历史记录。

8.3 支持资源

[TI E2E™ 中文支持论坛](#) 是工程师的重要参考资料，可直接从专家处获得快速、经过验证的解答和设计帮助。搜索现有解答或提出自己的问题，获得所需的快速设计帮助。

链接的内容由各个贡献者“按原样”提供。这些内容并不构成 TI 技术规范，并且不一定反映 TI 的观点；请参阅 TI 的 [使用条款](#)。

8.4 Trademarks

PowerPAD™ and TI E2E™ are trademarks of Texas Instruments.

所有商标均为其各自所有者的财产。

8.5 静电放电警告



静电放电 (ESD) 会损坏这个集成电路。德州仪器 (TI) 建议通过适当的预防措施处理所有集成电路。如果不遵守正确的处理和安装程序，可能会损坏集成电路。

ESD 的损坏小至导致微小的性能降级，大至整个器件故障。精密的集成电路可能更容易受到损坏，这是因为非常细微的参数更改都可能会导致器件与其发布的规格不相符。

8.6 术语表

[TI 术语表](#) 本术语表列出并解释了术语、首字母缩略词和定义。

9 Revision History

注：以前版本的页码可能与当前版本的页码不同

Changes from Revision * (December 2020) to Revision A (October 2024)	Page
• Changed Charged-device model (CDM) value from 250V to 1000V.....	5

10 Mechanical, Packaging, and Orderable Information

The following pages include mechanical, packaging, and orderable information. This information is the most current data available for the designated devices. This data is subject to change without notice and revision of this document. For browser-based versions of this data sheet, refer to the left-hand navigation.

PACKAGING INFORMATION

Orderable Device	Status (1)	Package Type	Package Drawing	Pins	Package Qty	Eco Plan (2)	Lead finish/ Ball material (6)	MSL Peak Temp (3)	Op Temp (°C)	Device Marking (4/5)	Samples
TMUXHS4412IRUAR	ACTIVE	WQFN	RUA	42	3000	RoHS & Green	NIPDAU	Level-2-260C-1 YEAR	-40 to 105	HS4412	Samples
TMUXHS4412IRUAT	ACTIVE	WQFN	RUA	42	250	RoHS & Green	NIPDAU	Level-2-260C-1 YEAR	-40 to 105	HS4412	Samples
TMUXHS4412RUAR	ACTIVE	WQFN	RUA	42	3000	RoHS & Green	NIPDAU	Level-2-260C-1 YEAR	0 to 70	HS4412	Samples
TMUXHS4412RUAT	ACTIVE	WQFN	RUA	42	250	RoHS & Green	NIPDAU	Level-2-260C-1 YEAR	0 to 70	HS4412	Samples

(1) The marketing status values are defined as follows:

ACTIVE: Product device recommended for new designs.

LIFEBUY: TI has announced that the device will be discontinued, and a lifetime-buy period is in effect.

NRND: Not recommended for new designs. Device is in production to support existing customers, but TI does not recommend using this part in a new design.

PREVIEW: Device has been announced but is not in production. Samples may or may not be available.

OBSELETE: TI has discontinued the production of the device.

(2) **RoHS:** TI defines "RoHS" to mean semiconductor products that are compliant with the current EU RoHS requirements for all 10 RoHS substances, including the requirement that RoHS substance do not exceed 0.1% by weight in homogeneous materials. Where designed to be soldered at high temperatures, "RoHS" products are suitable for use in specified lead-free processes. TI may reference these types of products as "Pb-Free".

RoHS Exempt: TI defines "RoHS Exempt" to mean products that contain lead but are compliant with EU RoHS pursuant to a specific EU RoHS exemption.

Green: TI defines "Green" to mean the content of Chlorine (Cl) and Bromine (Br) based flame retardants meet JS709B low halogen requirements of <=1000ppm threshold. Antimony trioxide based flame retardants must also meet the <=1000ppm threshold requirement.

(3) MSL, Peak Temp. - The Moisture Sensitivity Level rating according to the JEDEC industry standard classifications, and peak solder temperature.

(4) There may be additional marking, which relates to the logo, the lot trace code information, or the environmental category on the device.

(5) Multiple Device Markings will be inside parentheses. Only one Device Marking contained in parentheses and separated by a "-" will appear on a device. If a line is indented then it is a continuation of the previous line and the two combined represent the entire Device Marking for that device.

(6) Lead finish/Ball material - Orderable Devices may have multiple material finish options. Finish options are separated by a vertical ruled line. Lead finish/Ball material values may wrap to two lines if the finish value exceeds the maximum column width.

Important Information and Disclaimer:The information provided on this page represents TI's knowledge and belief as of the date that it is provided. TI bases its knowledge and belief on information provided by third parties, and makes no representation or warranty as to the accuracy of such information. Efforts are underway to better integrate information from third parties. TI has taken and

continues to take reasonable steps to provide representative and accurate information but may not have conducted destructive testing or chemical analysis on incoming materials and chemicals. TI and TI suppliers consider certain information to be proprietary, and thus CAS numbers and other limited information may not be available for release.

In no event shall TI's liability arising out of such information exceed the total purchase price of the TI part(s) at issue in this document sold by TI to Customer on an annual basis.

TAPE AND REEL INFORMATION

QUADRANT ASSIGNMENTS FOR PIN 1 ORIENTATION IN TAPE

*All dimensions are nominal

Device	Package Type	Package Drawing	Pins	SPQ	Reel Diameter (mm)	Reel Width W1 (mm)	A0 (mm)	B0 (mm)	K0 (mm)	P1 (mm)	W (mm)	Pin1 Quadrant
TMUXHS4412IRUAR	WQFN	RUA	42	3000	330.0	16.4	3.8	9.3	1.0	8.0	16.0	Q1
TMUXHS4412IRUAT	WQFN	RUA	42	250	180.0	16.4	3.8	9.3	1.0	8.0	16.0	Q1
TMUXHS4412RUAR	WQFN	RUA	42	3000	330.0	16.4	3.8	9.3	1.0	8.0	16.0	Q1
TMUXHS4412RUAT	WQFN	RUA	42	250	180.0	16.4	3.8	9.3	1.0	8.0	16.0	Q1

TAPE AND REEL BOX DIMENSIONS



*All dimensions are nominal

Device	Package Type	Package Drawing	Pins	SPQ	Length (mm)	Width (mm)	Height (mm)
TMUXHS4412IRUAR	WQFN	RUA	42	3000	367.0	367.0	35.0
TMUXHS4412IRUAT	WQFN	RUA	42	250	210.0	185.0	35.0
TMUXHS4412RUAR	WQFN	RUA	42	3000	367.0	367.0	35.0
TMUXHS4412RUAT	WQFN	RUA	42	250	210.0	185.0	35.0

GENERIC PACKAGE VIEW

RUA 42

WQFN - 0.8 mm max height

9 x 3.5, 0.5 mm pitch

PLASTIC QUAD FLATPACK - NO LEAD

This image is a representation of the package family, actual package may vary.
Refer to the product data sheet for package details.

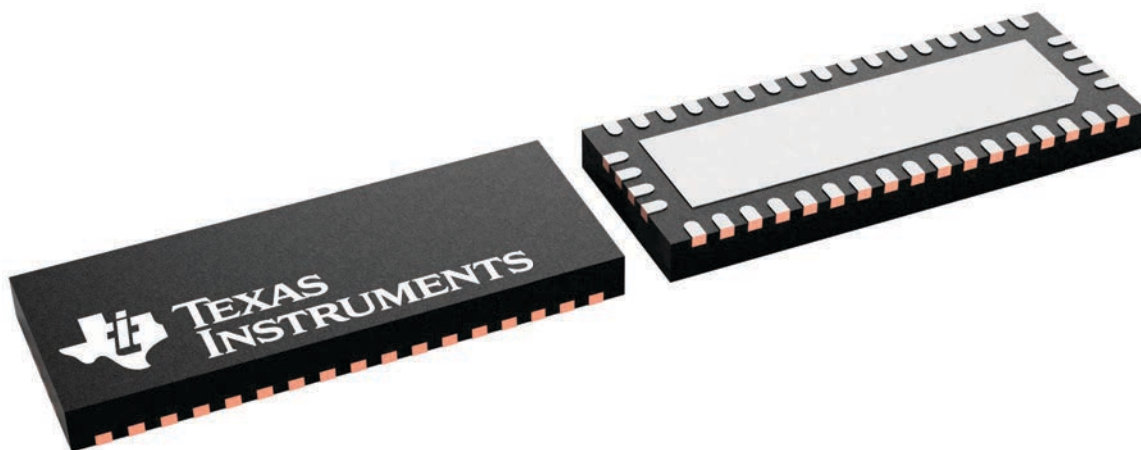

4226504/A

EXAMPLE STENCIL DESIGN

RUA0042A

WQFN - 0.8 mm max height

PLASTIC QUAD FLATPACK - NO LEAD

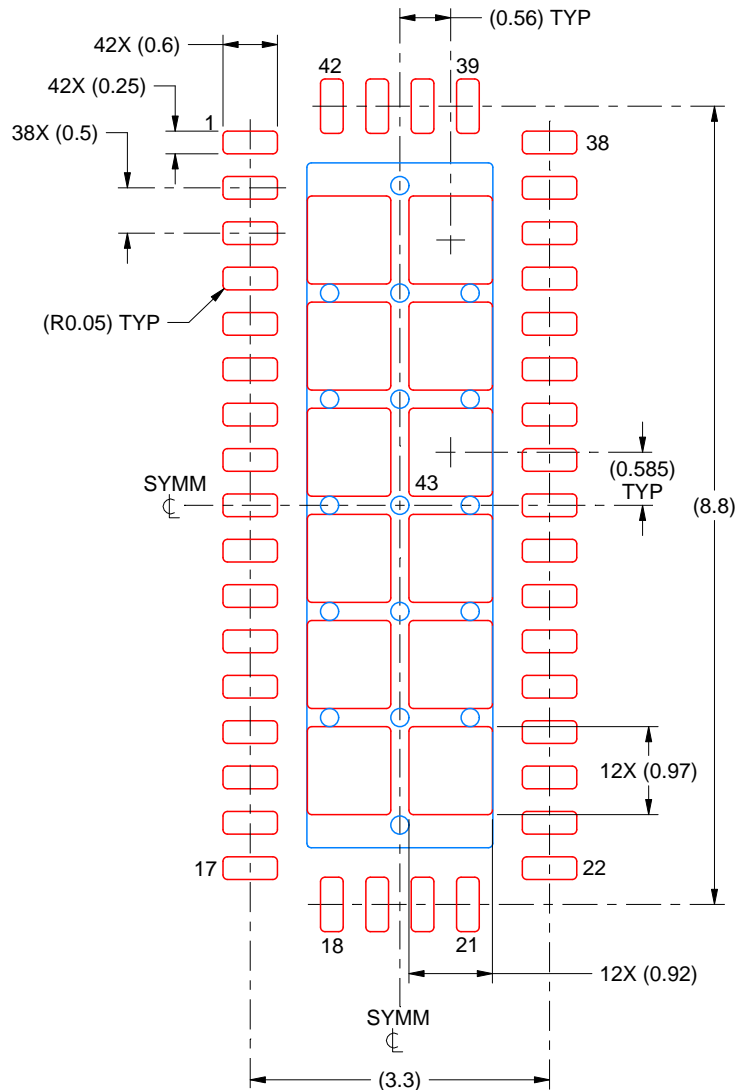

SOLDER PASTE EXAMPLE
BASED ON 0.125 MM THICK STENCIL
SCALE: 12X

EXPOSED PAD 43
69% PRINTED SOLDER COVERAGE BY AREA UNDER PACKAGE

4219139/A 03/2020

NOTES: (continued)

6. Laser cutting apertures with trapezoidal walls and rounded corners may offer better paste release. IPC-7525 may have alternate design recommendations.

重要声明和免责声明

TI“按原样”提供技术和可靠性数据（包括数据表）、设计资源（包括参考设计）、应用或其他设计建议、网络工具、安全信息和其他资源，不保证没有瑕疵且不做任何明示或暗示的担保，包括但不限于对适销性、某特定用途方面的适用性或不侵犯任何第三方知识产权的暗示担保。

这些资源可供使用 TI 产品进行设计的熟练开发人员使用。您将自行承担以下全部责任：(1) 针对您的应用选择合适的 TI 产品，(2) 设计、验证并测试您的应用，(3) 确保您的应用满足相应标准以及任何其他功能安全、信息安全、监管或其他要求。

这些资源如有变更，恕不另行通知。TI 授权您仅可将这些资源用于研发本资源所述的 TI 产品的应用。严禁对这些资源进行其他复制或展示。您无权使用任何其他 TI 知识产权或任何第三方知识产权。您应全额赔偿因在这些资源的使用中对 TI 及其代表造成的任何索赔、损害、成本、损失和债务，TI 对此概不负责。

TI 提供的产品受 [TI 的销售条款](#) 或 [ti.com](#) 上其他适用条款/TI 产品随附的其他适用条款的约束。TI 提供这些资源并不会扩展或以其他方式更改 TI 针对 TI 产品发布的适用的担保或担保免责声明。

TI 反对并拒绝您可能提出的任何其他或不同的条款。

邮寄地址：Texas Instruments, Post Office Box 655303, Dallas, Texas 75265
Copyright © 2024，德州仪器 (TI) 公司