

TPIC1021 LIN 物理接口

1 特性

- 符合 LIN 物理层规范修订版本 2.1，并符合适用于 LIN 的 SAEJ2602 推荐实践要求
- LIN 总线速度高达 20kbps
- LIN 引脚提供 12kV (人体放电模型) ESD 保护
- LIN 引脚可处理 -40V 至 40V 的电压
- 可在汽车环境中耐受瞬态损伤 (ISO 7637)
- 7V 至 27V 的直流电源工作电压范围
- 两种工作模式：正常模式和低功耗 (睡眠) 模式
- 低功耗模式下，电流消耗低
- 可通过 LIN 总线、唤醒输入 (外部开关) 或主机 MCU 唤醒
- 使用 5V 或者 3.3V I/O 引脚连接到 MCU
- TXD 引脚上提供显性状态超时保护
- RXD 引脚上提供唤醒请求功能
- 使用 INH 引脚控制外部稳压器
- 集成上拉电阻器和串联二极管适用于 LIN 响应器应用
- 低 EME (电磁辐射)、高 EMI (电磁抗扰度)
- 针对电池短路或接地短路提供总线端子短路保护
- 具有热保护功能
- 系统级接地断开失效防护
- 系统级接地漂移运行
- 未供电节点不会干扰网络

2 应用

- 工业感应
- 白色家电分布式控制

3 说明

TPIC1021 是 LIN (本地互连网络) 物理接口，集成了具有唤醒和保护功能的串行收发器。LIN 总线为单线制双向总线，通常用于低速车载网络，波特率范围为 2.4-20kbps。

LIN 总线有两个逻辑值：显性状态 (电压接近接地值) 表示逻辑值 0，而隐性状态 (电压接近电池值) 表示逻辑值 1。

在隐性状态下，LIN 总线由 TPIC1021 内部上拉电阻器 (30kΩ) 和串联二极管拉高，因此响应器应用无需外部上拉元件。指挥器应用需要外部上拉电阻器 (1kΩ) 及串联二极管。

器件信息

器件型号	封装 ⁽¹⁾	封装尺寸 (标称值)
TPIC1021	SOIC (8)	4.90mm × 3.91mm

(1) 如需了解所有可用封装，请参阅数据表末尾的可订购产品附录。

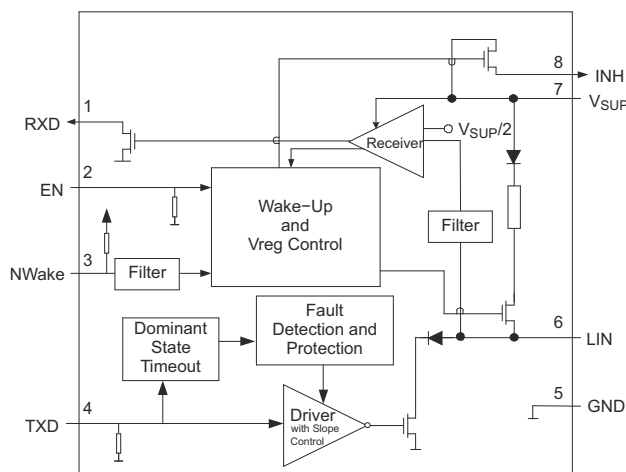

功能方框图



Table of Contents

1 特性.....	1	8.2 Functional Block Diagram.....	8
2 应用.....	1	8.3 Feature Description.....	8
3 说明.....	1	8.4 Device Functional Modes.....	10
4 Revision History.....	2	9 Application and Implementation.....	13
5 说明 (续).....	3	9.1 Application Information.....	13
6 Pin Configuration and Functions.....	3	9.2 Typical Application.....	13
7 Specifications.....	4	9.3 Power Supply Recommendations.....	14
7.1 Absolute Maximum Ratings.....	4	9.4 Layout.....	14
7.2 ESD Ratings.....	4	10 Device and Documentation Support.....	16
7.3 Recommended Operating Conditions.....	4	10.1 接收文档更新通知.....	16
7.4 Thermal Information.....	4	10.2 支持资源.....	16
7.5 Electrical Characteristics.....	5	10.3 Trademarks.....	16
7.6 Timing Requirements.....	6	10.4 Electrostatic Discharge Caution.....	16
7.7 Typical Characteristics.....	7	10.5 术语表.....	16
8 Detailed Description.....	8	11 Mechanical, Packaging, and Orderable Information.....	16
8.1 Overview.....	8		

4 Revision History

Changes from Revision D (June 2015) to Revision E (May 2022)	Page
• 将“特性”从“...符合修订版本 2.0”更改为“...符合修订版本 2.1”.....	1
• 将提到的所有旧术语实例更改为“指挥官”和“响应者”.....	1
• 将说明 (续) 中的“LIN 物理层规范修订版本 2.0”更改为“LIN 物理层规范修订版本 2.1”.....	3
• Added: (LIN 2.1 compatible) to Note 2 of the <i>Timing Requirements</i>	6
• Changed paragraph three in the Transmitter Characteristics section.....	8
• Changed three instances of "IHN" to "INH" in 图 8-1.....	10

Changes from Revision C (July 2005) to Revision D (June 2015)	Page
• 添加了引脚配置和功能部分、ESD 等级表、特性说明部分、器件功能模式、应用和实施部分、电源相关建议部分、布局部分、器件和文档支持部分以及机械、封装和可订购信息部分.....	1

5 说明 (续)

如 LIN 物理层规范修订版本 2.1 中所述，借助具有控制功能的限流波形整形低侧驱动器，TPIC1021 将 TXD 引脚上的 LIN 协议输出数据流转换为 LIN 总线信号。接收器转换 LIN 总线上的数据流，然后通过 RXD 引脚输出数据流。

在低功耗模式下，即使唤醒电路保持工作状态，TPIC1021 也需要非常低的静态电流，从而支持通过 LIN 总线进行远程唤醒，或者通过 NWake 或 EN 引脚进行本地唤醒。

TPIC1021 旨在用于恶劣的汽车环境。该器件可处理从 40V 向下至接地的 LIN 总线电压摆幅，并且可在 -40V 的电压下运行。该器件还可在接地漂移或电源电压断开的情况下防止反馈电流经 LIN 流向电源输入。它还具有欠压、过热和接地失效保护功能。如果发生故障，输出会立即关断，并在排除故障之前一直保持关断状态。

6 Pin Configuration and Functions



图 6-1. D Package, 8-Pin SOIC

表 6-1. Pin Functions

PIN		TYPE	DESCRIPTION
NO.	NAME		
1	RXD	O	RXD output (open drain) pin interface reporting state of LIN bus voltage
2	ED	I	Enable input pin
3	NWake	I	High voltage input pin for device wake up
4	TXD	I	TXD input pin interface to control state of LIN output
5	GND	I	Ground connection
6	LIN	I/O	LIN bus pin single wire transmitter and receiver
7	V _{SUP}	Supply	Device supply pin (connected to battery in series with external reverse blocking diode)
8	INH	O	Inhibit pin controls external voltage regulator with inhibit input

7 Specifications

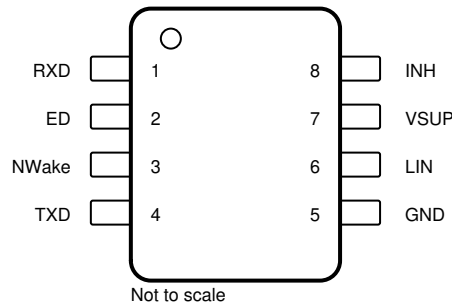
7.1 Absolute Maximum Ratings

over operating free-air temperature range (unless otherwise noted)⁽¹⁾

		MIN	MAX	UNIT	
V _{SUP} ⁽²⁾	Supply line supply voltage	Continuous	0	27	V
		Transient	0	40	V
NWake DC and transient input voltage (through 33-kΩ serial resistor)		- 1	40	V	
Logic pin input voltage (RXD, TXD, EN)		- 0.3	5.5	V	
LIN DC input voltage		- 40	40	V	
T _A	Operational free-air temperature	- 40	125	°C	
T _J	Junction temperature	- 40	150	°C	
Thermal shutdown			200	°C	
Thermal shutdown hysteresis			25	°C	
T _{stg}	Storage temperature range	- 40	165	°C	

- (1) Stresses beyond those listed under Absolute Maximum Ratings may cause permanent damage to the device. These are stress ratings only and functional operation of the device at these or any other conditions beyond those indicated under [# 7.3](#) is not implied. Exposure to absolute-maximum-rated conditions for extended periods may affect device reliability.
- (2) All voltage values are with respect to GND.

7.2 ESD Ratings

			VALUE	UNIT	
V _(ESD)	Electrostatic discharge	Human body model (HBM), per ANSI/ESDA/JEDEC JS-001 ^{(1) (2)}	LIN pin	±12000	V
			NWake pin	±9000	
			All other pins	±3000	
		Machine model ⁽³⁾	LIN and NWake pins	±400	
			All other pins	±200	

- (1) JEDEC document JEP155 states that 500-V HBM allows safe manufacturing with a standard ESD control process.
- (2) The human body model is a 100-pF capacitor discharged through a 1.5-kΩ resistor into each pin.
- (3) The machine model is a 200-pF capacitor through a 10-Ω resistor and a 0.75-μH coil.

7.3 Recommended Operating Conditions

over operating free-air temperature range (unless otherwise noted)

		MIN	NOM	MAX	UNIT
T _{SUP}	Supply voltage	7		27	V
T _{AMB}	Ambient temperature	- 40		125	°C

7.4 Thermal Information

THERMAL METRIC ⁽¹⁾		TPIC1021	UNIT
		D (SOIC)	
		8 PINS	
R _{θJA}	Junction-to-ambient thermal resistance	145	°C/W
R _{θJC(top)}	Junction-to-case (top) thermal resistance	61.9	°C/W
R _{θJB}	Junction-to-board thermal resistance	55.5	°C/W
ψ _{JT}	Junction-to-top characterization parameter	14.3	°C/W
ψ _{JB}	Junction-to-board characterization parameter	55	°C/W

- (1) For more information about traditional and new thermal metrics, see the [Semiconductor and IC Package Thermal Metrics](#) application report.

7.5 Electrical Characteristics

 $V_{SUP} = 7\text{ V to }27\text{ V}$, $T_A = -40^\circ\text{C to }125^\circ\text{C}$ (unless otherwise noted)

PARAMETER		TEST CONDITIONS	MIN	TYP ⁽¹⁾	MAX	UNIT
SUPPLY						
	Operational supply voltage ⁽²⁾		7	14	27	V
	Nominal supply line voltage ⁽²⁾		7	14	18	V
	V_{SUP} undervoltage threshold ⁽²⁾			4.5		V
I_{CC}	Supply Current	Normal Mode, EN = 1, Bus dominant (total bus load > 500 Ω) ⁽³⁾		1.2	2.5	mA
		Standby Mode, EN = 0, Bus dominant (total bus load > 500 Ω) ⁽³⁾		1	2.1	mA
		Normal Mode, EN = 1, Bus recessive		300	500	μA
		Standby Mode, EN = 0, Bus recessive		300	500	μA
		Low Power Mode, EN = 0, $V_{SUP} < 14\text{ V}$, $NWake = V_{SUP}$, $LIN = V_{SUP}$		20	50	μA
		Low Power Mode, EN = 0, $14\text{ V} < V_{SUP} < 27\text{ V}$, $NWake = V_{SUP}$, $LIN = V_{SUP}$		50	100	μA
RXD OUTPUT PIN						
V_O	Output voltage		-0.3		5.5	V
I_{OL}	Low-level output current, open drain	LIN = 0 V, RXD = 0.4 V	3.5			mA
I_{IKG}	Leakage current, high-level	LIN = V_{SUP} , RXD = 5 V	-5	0	5	μA
TXD INPUT PIN						
V_{IL}	Low-level input voltage ⁽²⁾		-0.3		0.8	V
V_{IH}	High-level input voltage ⁽²⁾		2		5.5	V
V_{IT}	Input threshold hysteresis voltage ⁽²⁾		30		500	mV
	Pull-down resistor		125	350	800	k Ω
I_{IL}	Low-level input current	TXD = 0	-5	0	5	μA
LIN PIN (Referenced to V_{SUP})						
V_{OH}	High-level output voltage ⁽²⁾	LIN recessive, TXD = High, $I_O = 0\text{ mA}$	$V_{SUP}-1\text{V}$			V
V_{OL}	Low-level output voltage ⁽²⁾	LIN dominant, TXD = Low, $I_O = 40\text{ mA}$	0		$0.2 \times V_{SUP}$	V
	Pull-up resistor to V_{SUP}		20	30	60	k Ω
I_L	Limiting current	TXD = Low	50	150	250	mA
I_{IKG}	Leakage current	LIN = V_{SUP}	-5	0	5	μA
V_{IL}	Low-level input voltage ⁽²⁾	LIN dominant	$0 \times V_{SUP}$		$0.4 \times V_{SUP}$	V
V_{IH}	High-level input voltage ⁽²⁾	LIN recessive	$0.6 \times V_{SUP}$		V_{SUP}	V
V_{IT}	Input threshold voltage ⁽²⁾		$0.4 \times V_{SUP}$	$0.5 \times V_{SUP}$	$0.6 \times V_{SUP}$	V
V_{hys}	Hysteresis voltage ⁽²⁾		$0.05 \times V_{SUP}$		$0.175 \times V_{SUP}$	V
V_{IL}	Low-level input voltage for wake-up ⁽²⁾		0		$0.4 \times V_{SUP}$	V
EN PIN						
V_{IL}	Low-level input voltage ⁽²⁾		-0.3		0.8	V
V_{IH}	High-level input voltage ⁽²⁾		2		5.5	V
V_{hys}	Hysteresis voltage ⁽²⁾		30		500	mV
	Pull-down resistor		125	350	800	k Ω
I_{IL}	Low-level input current	EN = 0 V	-5	0	5	μA

7.5 Electrical Characteristics (continued)

V_{SUP} = 7 V to 27 V, T_A = - 40°C to 125°C (unless otherwise noted)

PARAMETER	TEST CONDITIONS	MIN	TYP ⁽¹⁾	MAX	UNIT		
INH PIN							
V _O	DC output voltage	Transient voltage		-0.3	V _{SUP} +0.3	V	
I _O	Output current			-50	2	mA	
R _{on}	On state resistance	Between V _{SUP} and INH, INH = 2 mA drive, Normal or Standby Mode		25	40	100	Ω
I _{IKG}	Leakage current	Low Power mode, 0 < INH < V _{SUP}		-5	0	5	μA
NWake PIN							
V _{IL}	Low-level input voltage ⁽²⁾			-0.3	V _{SUP} -3.3	V	
V _{IH}	High-level input voltage ⁽²⁾			V _{SUP} -1	V _{SUP} +0.3	V	
	Pull-up current	NWake = 0 V		-40	-10	-4	μA
I _{IKG}	Leakage current	V _{SUP} = NWake		-5	0	5	μA
THERMAL SHUTDOWN							
	Shutdown junction thermal temperature			185		°C	

- (1) Typical values are given for V_{SUP} = 14 V at 25°C.
- (2) All voltages are defined with respect to ground; positive currents flow into the TPIC1021 device.
- (3) In the dominant state the supply current increases as the supply voltage increases due to the integrated LIN responder termination resistance. At higher voltages the majority of supply current is through the termination resistance. The minimum resistance of the LIN responder termination is 20 kΩ so the maximum supply current attributed to the termination is: I_{SUP (dom) max termination} ≈ (V_{SUP} - (V_{LIN_Dominant}+0.7 V) / 20 kΩ.

7.6 Timing Requirements

		MIN	NOM	MAX	UNIT
D1	Duty cycle 1 ^{(1) (2)}	T _{HREC(max)} = 0.744×V _{SUP} , T _{HDOM(max)} = 0.581×V _{SUP} , V _{SUP} = 7.0 V to 18 V, t _{BIT} = 50 μs (20 kbps), See Fig 7-1		0.396	
D2	Duty cycle 2 ^{(1) (2)}	T _{HREC(max)} = 0.284×V _{SUP} , T _{HDOM(max)} = 0.422×V _{SUP} , V _{SUP} = 7.6 V to 18 V, t _{BIT} = 50 μs (20 kbps), See Fig 7-1			0.581
D3	Duty cycle 3 ^{(1) (2)}	T _{HREC(max)} = 0.778×V _{SUP} , T _{HDOM(max)} = 0.616×V _{SUP} , V _{SUP} = 7.0 V to 18 V, t _{BIT} = 96 μs (10.4 kbps), See Fig 7-1		0.417	
D4	Duty cycle 4 ^{(1) (2)}	T _{HREC(max)} = 0.251×V _{SUP} , T _{HDOM(max)} = 0.389×V _{SUP} , V _{SUP} = 7.6 V to 18 V, t _{BIT} = 96 μs (10.4 kbps), See Fig 7-1			0.590
t _{rx_pdr}	Receiver rising propagation delay time	R _L = 2.4 kΩ, C _L = 20 pF, See Fig 7-1			6 μs
t _{rx_pdf}	Receiver rising propagation delay time	R _L = 2.4 kΩ, C _L = 20 pF, See Fig 7-1			6 μs
t _{rx_sym}	Symmetry of receiver propagation delay time (rising edge)	with respect to falling edge, See Fig 7-1		- 2	2 μs
t _{NWake}	NWake filter time for local wake-up	See Fig 7-1		25	50 100 μs
t _{LINBUS}	LIN wake-up filter time (dominant time for wake-up via LIN bus)	See Fig 7-1		25	50 100 μs
t _{DST}	Dominant state timeout ⁽³⁾	See Fig 7-1		6	9 14 ms

- (1) Duty cycle = t_{BUS_rec(min)} / (2×t_{BIT})
- (2) Duty Cycles: LIN Driver bus load conditions (CLINBUS, RLINBUS): Load1 = 1 nF, 1 kΩ; Load2 = 6.8 nF, 660 Ω; Load3 = 10 nF, 500 Ω. Duty Cycles 3 and 4 are defined for 10.4 kbps operation. The TPIC1021 also meets these lower speed requirements, while it is capable of the higher speed 20.0 kbps operation as specified by Duty Cycles 1 and 2. SAEJ2602 derives propagation delay equations from the LIN 2.0 duty cycle definitions (LIN 2.1 compatible), for details please refer to the SAEJ2602 specification.
- (3) Dominant state timeout will limit the minimum data rate to 2.4 kbps.



图 7-1. Definition of Bus Timing Parameters

7.7 Typical Characteristics



图 7-2. V_{OH} vs V_{SUPPLY} and Temperature

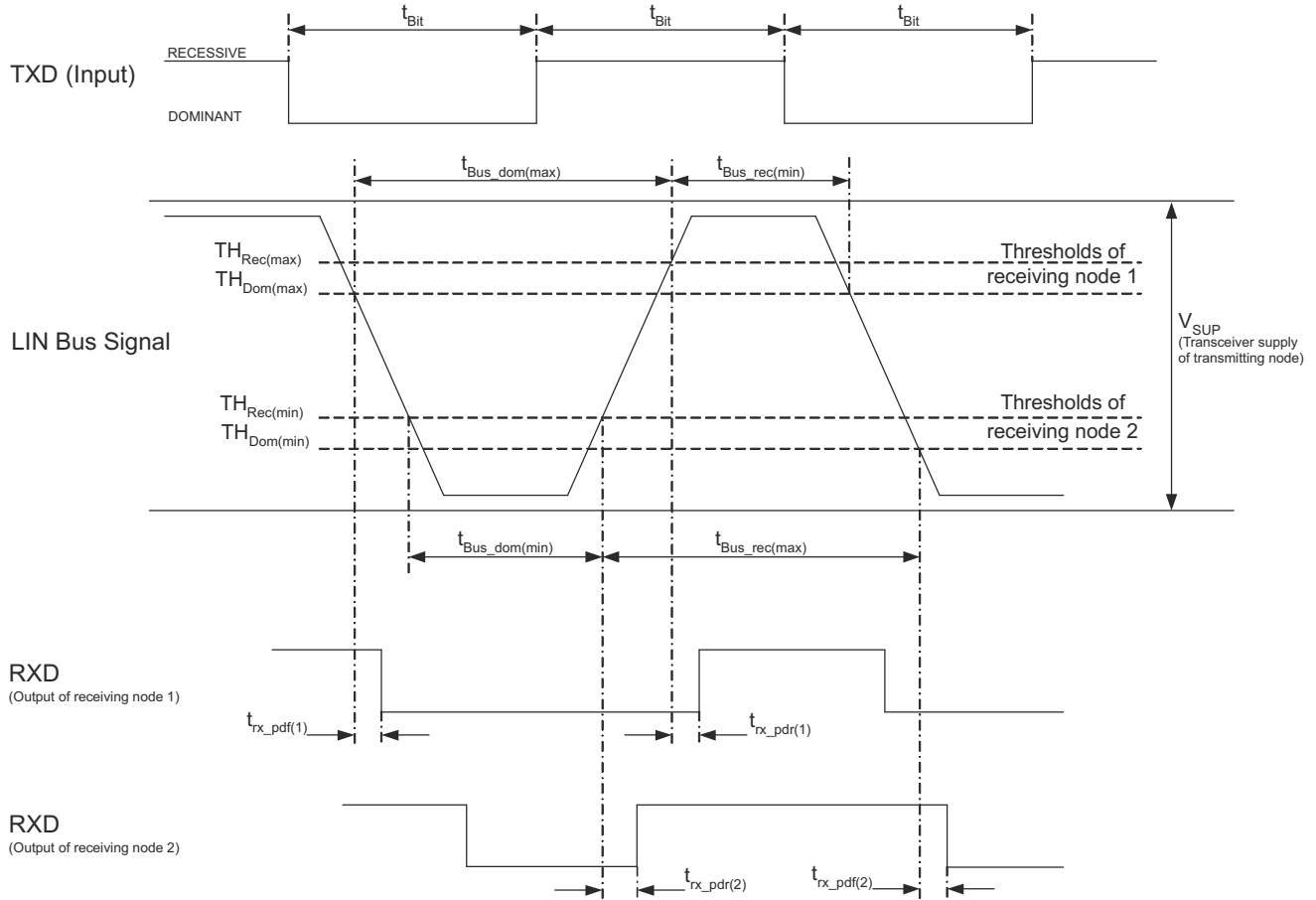

图 7-3. V_{OL} vs V_{SUPPLY} and Temperature

8 Detailed Description

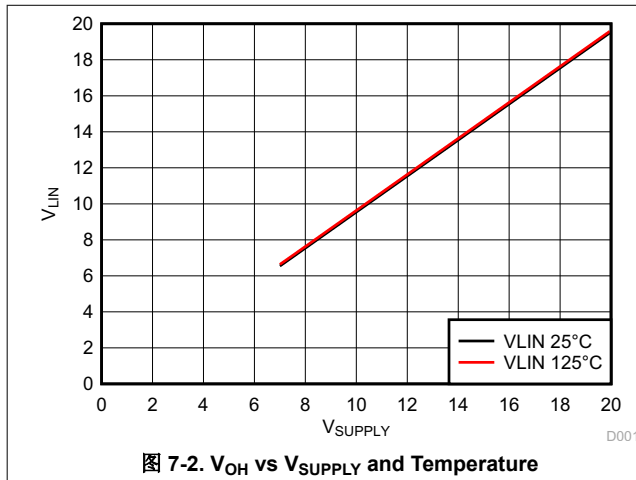
8.1 Overview

The TPIC1021 is a LIN (Local Interconnect Network) physical layer transceiver which integrates a serial transceiver with wake up and protection features. The LIN bus is a single wire, bi-directional bus that typically is used in low speed in vehicle networks with data rates that range from 2.4 kbps to 20 kbps.

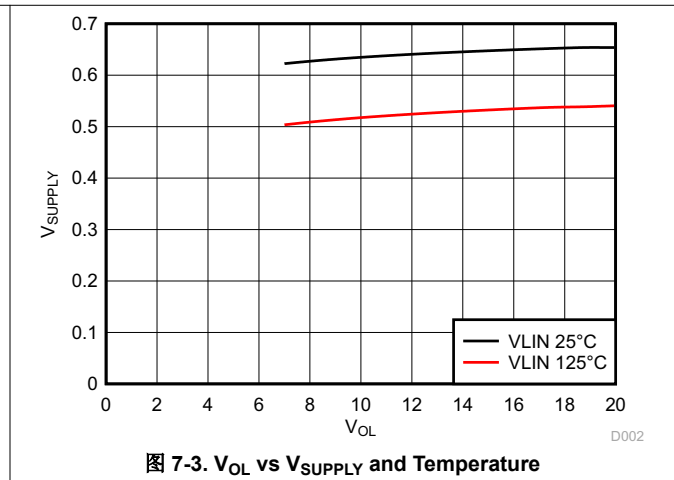
8.2 Functional Block Diagram

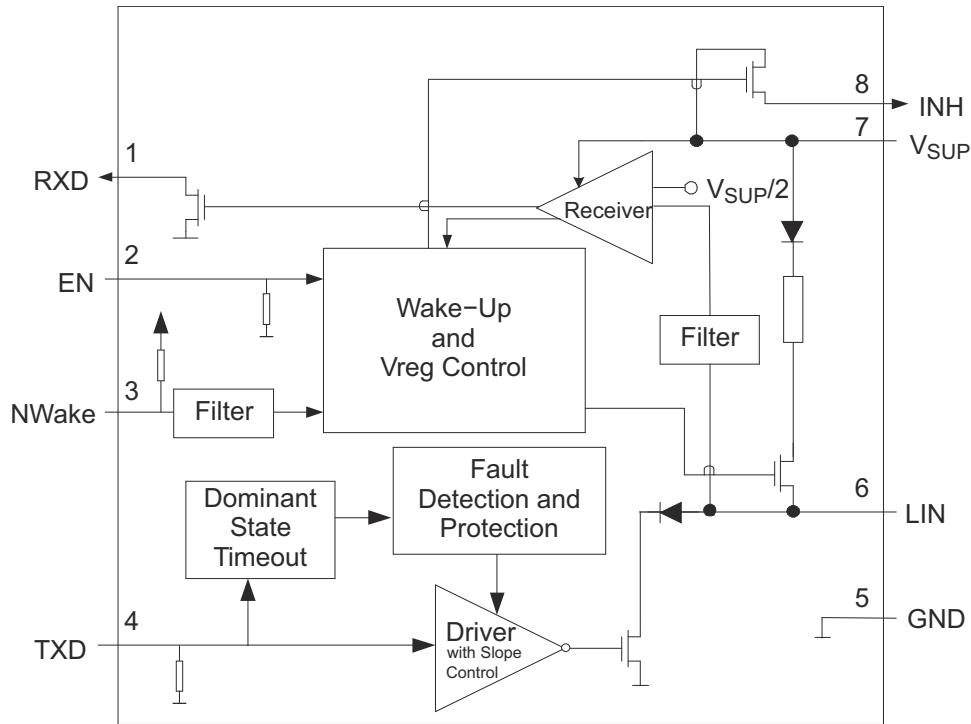

8.3 Feature Description

8.3.1 LIN Bus Pin

This I/O pin is the single-wire LIN bus transmitter and receiver.

8.3.1.1 Transmitter Characteristics

The driver is a low side transistor with internal current limitation and thermal shutdown. There is an internal 30-k Ω pull-up resistor with a serial diode structure to V_{sup} so no external pull-up components are required for LIN responder mode applications. An external pull-up resistor of 1 k Ω plus a series diode to V_{sup} must be added when the device is used for commander node applications.

Voltage on the LIN pin can go from -40 V to +40 V DC without any currents other than through the pull-up resistance. There are no reverse currents from the LIN bus to supply (V_{sup}), even in the event of a ground shift or loss of supply (V_{sup}).

The LIN thresholds and AC parameters are up-to-date with LIN Protocol Specification Revision 2.0, and compatible with Revision 2.1.

During a thermal shut down condition the driver is disabled.

8.3.1.2 Receiver Characteristics

The characteristic thresholds of the receiver are ratio-metric with the device supply pin. Typical thresholds are 50%, with a hysteresis between 5% and 17.5% of supply.

8.3.2 Transmit Input Pin (TXD)

This pin is the interface to the MCU's LIN Protocol Controller or SCI/UART used to control the state of the LIN output. When TXD is low, LIN output is dominant (near ground). When TXD is high, LIN output is recessive (near battery). TXD input structure is compatible with microcontrollers with 3.3 V and 5.0 V I/O. This pin has an internal pull-down resistor.

8.3.2.1 TXD Dominant State Timeout

If the TXD pin is inadvertently driven permanently low by a hardware or software application failure, the LIN bus is protected by TPIC1021's Dominant State Timeout Timer. This timer is triggered by a falling edge on the TXD pin. If the low signal remains on the TXD pin for longer than t_{DST} , the transmitter is disabled thus allowing the LIN bus to return to the recessive state and communication to resume on the bus. The timer is reset by a rising edge on TXD pin.

8.3.3 Receive Output Pin (RXD)

This pin is the interface to the LIN protocol controller or SCI/UART of the MCU, which reports the state of the LIN bus voltage. LIN recessive (near battery) is represented by a high level on RXD and LIN dominant (near ground) is represented by a low level on RXD. The RXD output structure is an open-drain output stage. This allows the TPIC1021 to be used with 3.3 V and 5 V I/O microcontrollers. If the microcontroller's RXD pin does not have an integrated pull-up, an external pull-up resistor to the microcontroller I/O supply voltage is required.

8.3.3.1 RXD Wake-up Request

When the TPIC1021 has been in low power mode and encounters a wake-up event from the LIN bus or NWake pin the RXD pin will go LOW while the device enters and remains in Standby Mode (until EN is re-asserted high and the device enters Normal Mode).

8.3.4 Ground (GND)

This is the TPIC1021 device ground connection. The TPIC1021 operates with a ground shift as long as the ground shift does not reduce V_{SUP} below the minimum operating voltage. If there is a loss of ground at the ECU level, the TPIC1021 does not have a significant current consumption on the LIN pin while in the recessive state (<100 μ A sourced via the LIN pin) and for the dominant state the pull-up resistor should be active.

8.3.5 Enable Input Pin (EN)

The enable input pin controls the operation mode of the TPIC1021 (Normal or Low Power Mode). When enable is high, the TPIC1021 is in normal mode allowing a transmission path from TXD to LIN and from LIN to RXD. When the enable input is low, the device is put into low power (sleep) mode and there are no transmission paths. The device can enter normal operating mode only after being woken up. The enable pin has an internal pull-down resistor to ensure the device remains in low power mode even if the enable pin floats.

8.3.6 NWake Input Pin (NWake)

The NWake input pin is a high-voltage input used to wake up the TPIC1021 from low power mode. NWake is usually connected to an external switch in the application. A falling edge on NWake with a low that is asserted longer than the filter time (t_{NWAKE}) results in a local wake-up. The NWake pin provides an internal pull-up current source to V_{SUP} .

8.3.7 Inhibit Output Pin (INH)

The inhibit output pin is used to control an external voltage regulator that has an inhibit input. When the TPIC1021 is in normal operating mode, the inhibit high-side switch is enabled and the external voltage regulator is activated. When TPIC1021 is in low power mode, the inhibit switch is turned off, which disables the voltage regulator. A wake-up event on for the TPIC1021 will return the INH pin to V_{SUP} level. The INH pin output current is limited to 2 mA. The INH pin can also drive an external transistor connected to an MCU interrupt input.

8.4 Device Functional Modes

8.4.1 Operating States



图 8-1. Operating States Diagram

表 8-1. Operating Modes

MODE	EN	RXD	LIN BUS TERMINATION	INH	TRANSMITTER	COMMENTS
Low Power	0	Floating	High impedance	High impedance	Off	
Standby	0	Low	30 kΩ (typical)	High	Off	Wake-up event detected, waiting on MCU to set EN
Normal	1	LIN bus data	30 kΩ (typical)	High	On	

8.4.1.1 Normal Mode

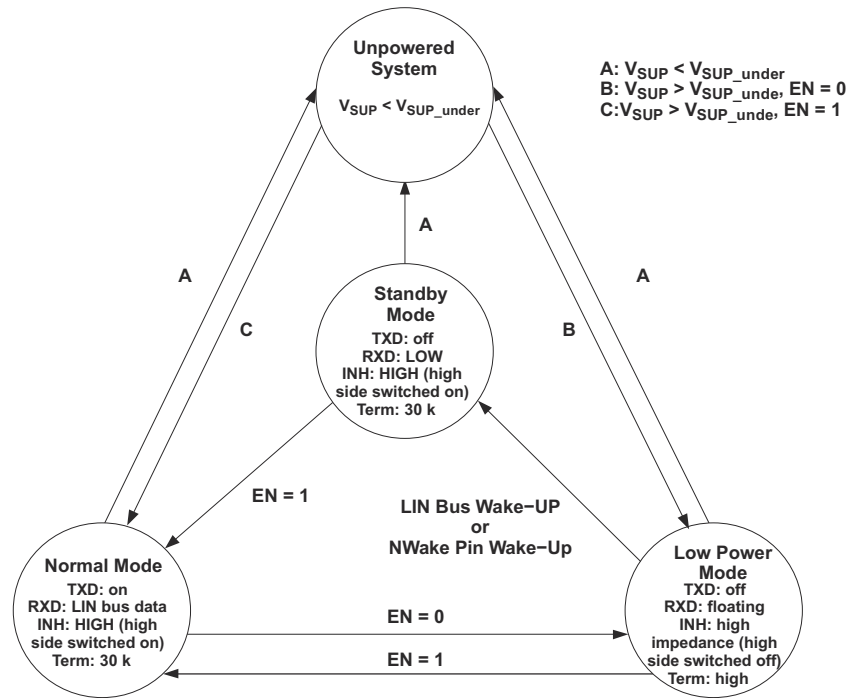
This is the normal operational mode where the receiver and driver are active. The receiver detects the data stream on the LIN bus and outputs it on the RXD pin for the LIN controller where recessive on the LIN bus is a digital high and dominate on the LIN bus is digital low. The driver transmits input data on the TXD pin to the LIN bus.

8.4.1.2 Low Power Mode

The power saving mode for the TPIC1021 and the default state after power-up (assuming EN=0). Even with the extremely low current consumption in this mode, the TPIC1021 can still wake-up from LIN bus activity, a falling edge on the NWake pin or if EN is set high. The LIN bus and NWake pins are filtered to prevent false wake-up events. The wake-up events must be active for their respective time periods: t_{LINBUS} , t_{NWake} .

The low power mode is entered by setting the EN pin low.

While the device is in low power mode the following conditions exist:

- The LIN bus driver is disabled and the internal LIN bus termination is switched off (to minimize power loss if LIN is short-circuited to ground).
- The normal receiver is disabled.
- The INH pin is high impedance.
- EN input, NWake input and the LIN wake-up receiver are active.

8.4.1.3 Wake-Up Events

There are three ways to wake-up the TPIC1021 from Low Power Mode.

- Remote wake-up via recessive (high) to dominant (low) state transition on LIN Bus where dominant bus state of 50% threshold is detected. The dominant state must be held for t_{LINBUS} filter time (to eliminate false wake ups from disturbances on the LIN Bus).
- Local wake-up via falling edge on NWake pin which is held low for filter time t_{NWake} (to eliminate false wake ups from disturbances on NWake).
- Local wake-up via EN being set high

8.4.1.4 Standby Mode

This mode is entered whenever a wake-up event occurs via the LIN bus or NWake pin while the TPIC1021 is in low power mode. The LIN bus responder termination circuit and the INH pin are turned on when standby mode is entered. The application system powers up once the INH pin is driven high assuming it is using a voltage regulator connected via INH pin. Standby Mode is signaled via a low level on RXD pin.

When EN pin is set high while the TPIC1021 is in Standby Mode the device returns to Normal Mode and the normal transmission paths from TXD to LIN bus and LIN bus to RXD are turned on.



图 8-2. Wake-Up Via LIN Bus Timing Diagram



图 8-3. Wake-Up Via NWake Timing Diagram

8.4.2 Supply Voltage (V_{SUP})

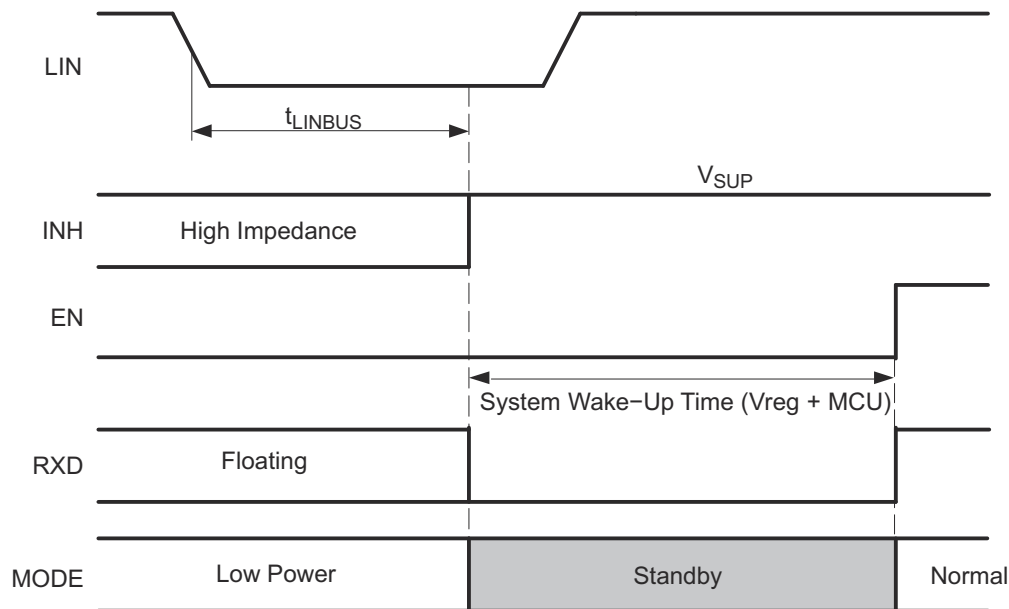
This is the TPIC1021 device power supply pin. This pin is connected to the battery through an external reverse battery blocking diode. The continuous DC operating voltage range for the TPIC1021 is from 7 V to +27 V. The V_{SUP} is protected for harsh automotive conditions of up to +40 V.

The device contains a reset circuit to avoid false bus messages during undervoltage conditions when V_{SUP} is less than V_{SUP_UNDER} .

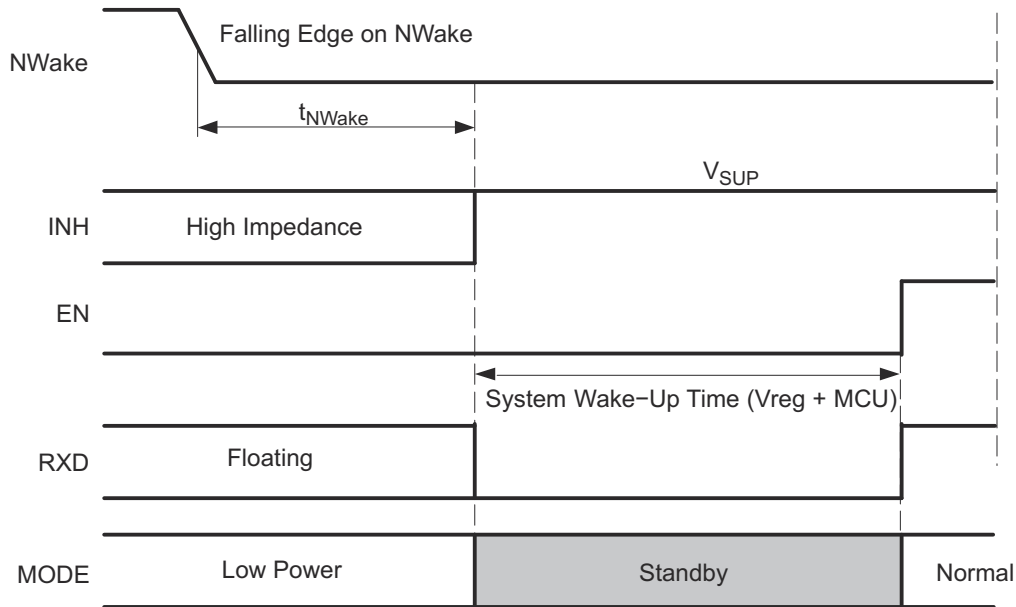
9 Application and Implementation

备注

Information in the following applications sections is not part of the TI component specification, and TI does not warrant its accuracy or completeness. TI's customers are responsible for determining suitability of components for their purposes. Customers should validate and test their design implementation to confirm system functionality.

9.1 Application Information

The TPIC1021 can be used as both a responder device and a commander device in a LIN network. It comes with the ability to support both remote wake-up requests and local wake-up requests.

9.2 Typical Application

The device comes with an integrated 30-k Ω pullup resistor and series diode for responder applications, and for commander applications an external 1-k Ω pullup with series blocking diode can be used. 图 9-1 shows the device being used in both types of applications.

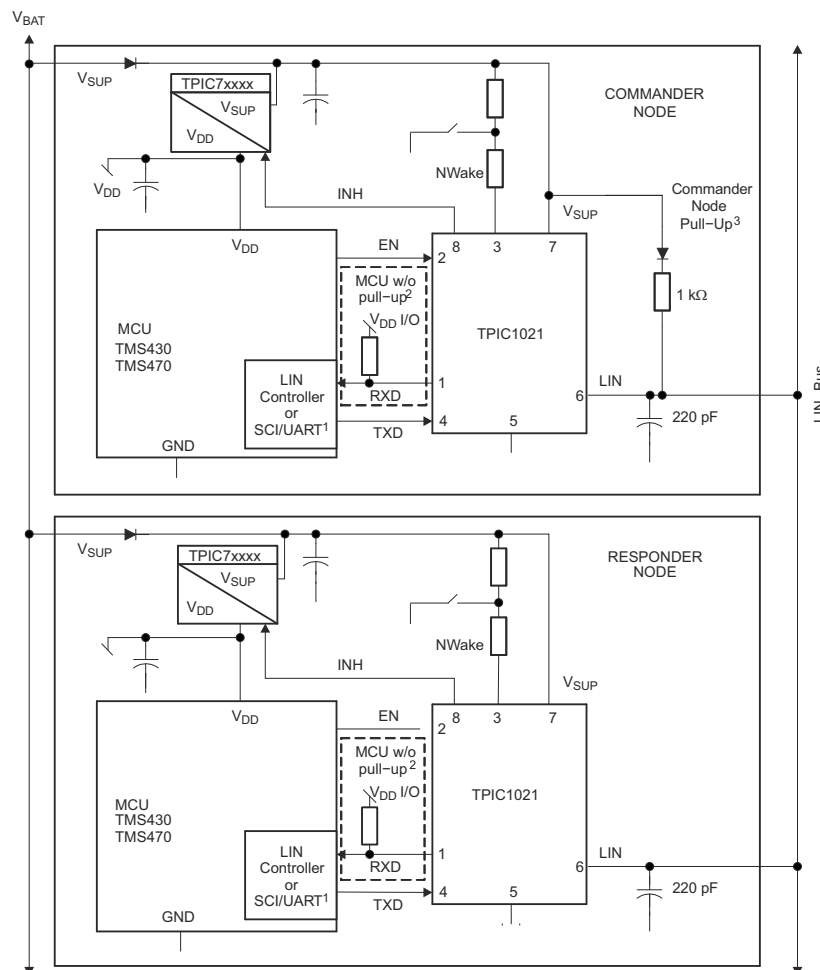

- A. See 1 in the 9.2.1 section
- B. See 2 in the 9.2.1 section
- C. See 3 in the 9.2.1 section

图 9-1. Typical Application Schematic

9.2.1 Design Requirements

For this design, use these requirements:

1. RXD on MCU or LIN Responder has internal pullup, no external pullup resistor is needed.
2. RXD on MCU or LIN Responder without internal pull-up, requires external pullup resistor.
3. Commander Node applications require an external 1-k Ω pullup resistor and serial diode.

9.2.2 Detailed Design Procedure

The RXD output structure is an open-drain output stage. This allows the TPIC1021 to be used with 3.3-V and 5-V I/O microcontrollers. If the RXD pin of the microcontroller does not have an integrated pull-up, an external pullup resistor to the microcontroller I/O supply voltage is required.

The V_{SUP} pin of the device should be decoupled with a 100-nF capacitor as close to the supply pin of the device as possible.

The NWAKE pin is a high voltage wake-up input to the device. If this pin is not being used it should be tied to V_{SUP}.

9.2.3 Application Curves

图 9-2 and 图 9-3 show the propagation delay from the TXD pin to the LIN pin for both the recessive to dominant and dominant to recessive states under lightly loaded conditions.

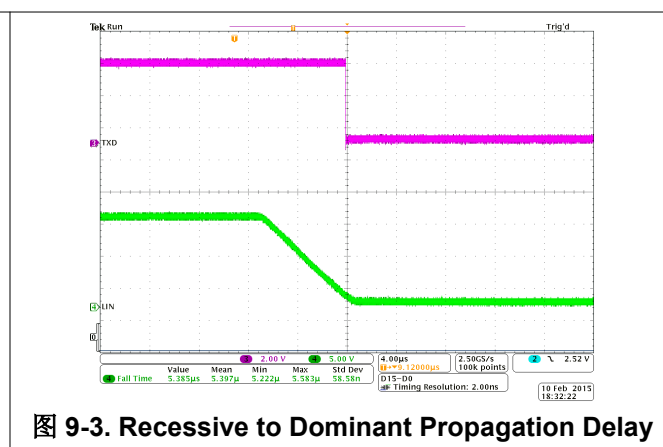
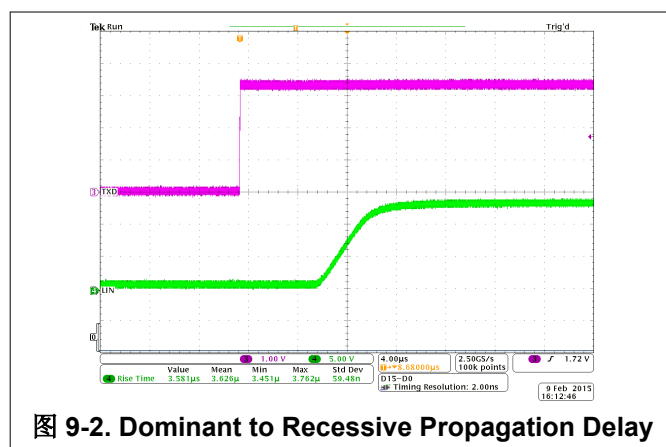

9.3 Power Supply Recommendations

The TPIC1021 was designed to operate directly off car battery, or any other DC supply ranging from 7 V to 27 V. A 100-nF decoupling capacitor should be placed as close to the V_{SUP} pin of the device as possible.

9.4 Layout

9.4.1 Layout Guidelines

- Pin 1 is the RXD output of the TPIC1021. It is an open drain output and requires an external pull-up resistor in the range of 1 to 10 k Ω to function properly. If the micro-processor paired with the transceiver does not have an integrated pullup and external resistor should be placed between RXD and the regulated voltage supply for the micro-processor.
- Pin 2 is the EN input pin for the device that is used to place the device in low power sleep mode. If this feature is not used on the device, the pin should be pulled high to the regulated voltage supply of the micro-processor through a series 1-k Ω to 10-k Ω series resistor. Additionally, a series resistor may be placed on the pin to limit the current on the digital lines in the case of an overvoltage fault.
- Pin 3 is a high-voltage local wake up input pin. The device is typically externally controlled by a normally open switch tied between NWAKE and ground. When the momentary switch is pressed the NWAKE pin is pulled to ground signaling a local wake-up event. A series resistor between VBATT and the switch, and NWAKE and

the switch should be placed to limit current. If the NWAKE local wake-up feature is not used, the pin can be tied to V_{SUP} through a 1-k Ω to 10-k Ω pullup resistor.

- Pin 4 is the transmit input signal to the device. A series resistor can be placed to limit the input current to the device in the case of an overvoltage on this pin. Also a capacitor to ground can be placed close to the input pin of the device to filter noise.
- Pin 5 is the ground connection of the device. This pin should be tied to a ground plane through a short trace with the use of two vias to limit total return inductance.
- Pin 6 is the LIN bus connection of the device. For responder applications a 220pF bus capacitor is implemented. For commander applications an additional series resistor and blocking diode should be placed between the LIN pin and the V_{SUP} pin.
- Pin 7 is the supply pin for the device. A 100-nF decoupling capacitor should be placed as close to the device as possible.
- Pin 8 is a high-voltage output pin that may be used to control the local power supplies. If this feature is not used the pin may be left floating.

备注

All ground and power connections should be made as short as possible and use at least two vias to minimize the total loop inductance.

9.4.2 Layout Example



图 9-4. Layout Example

10 Device and Documentation Support

10.1 接收文档更新通知

要接收文档更新通知，请导航至 ti.com 上的器件产品文件夹。点击 [订阅更新](#) 进行注册，即可每周接收产品信息更改摘要。有关更改的详细信息，请查看任何已修订文档中包含的修订历史记录。

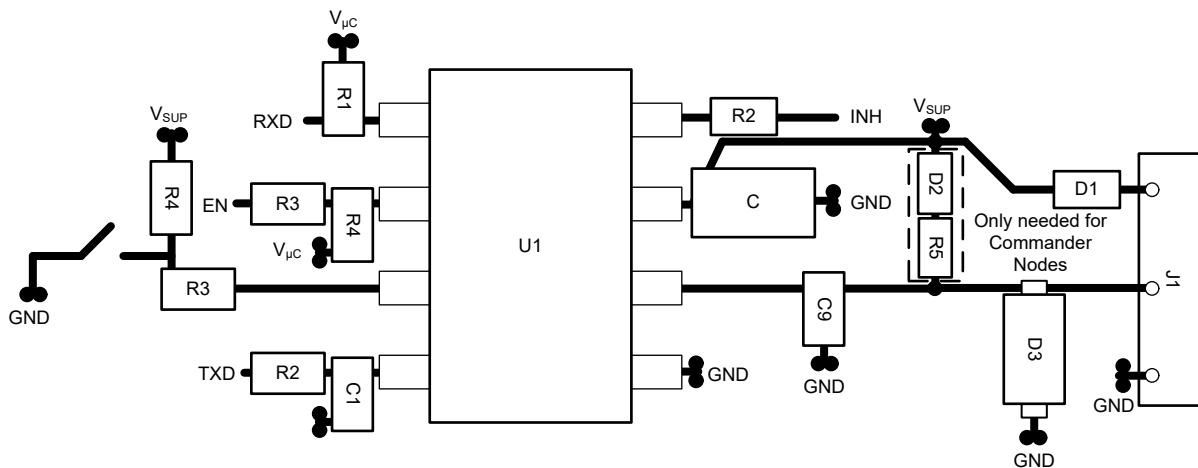
10.2 支持资源

[TI E2E™ 支持论坛](#) 是工程师的重要参考资料，可直接从专家获得快速、经过验证的解答和设计帮助。搜索现有解答或提出自己的问题可获得所需的快速设计帮助。

链接的内容由各个贡献者“按原样”提供。这些内容并不构成 TI 技术规范，并且不一定反映 TI 的观点；请参阅 TI 的《[使用条款](#)》。

10.3 Trademarks

TI E2E™ is a trademark of Texas Instruments.

所有商标均为其各自所有者的财产。

10.4 Electrostatic Discharge Caution



This integrated circuit can be damaged by ESD. Texas Instruments recommends that all integrated circuits be handled with appropriate precautions. Failure to observe proper handling and installation procedures can cause damage.

ESD damage can range from subtle performance degradation to complete device failure. Precision integrated circuits may be more susceptible to damage because very small parametric changes could cause the device not to meet its published specifications.

10.5 术语表

[TI 术语表](#) 本术语表列出并解释了术语、首字母缩略词和定义。

11 Mechanical, Packaging, and Orderable Information

The following pages include mechanical, packaging, and orderable information. This information is the most current data available for the designated devices. This data is subject to change without notice and revision of this document. For browser-based versions of this data sheet, refer to the left-hand navigation.

PACKAGING INFORMATION

Orderable Device	Status (1)	Package Type	Package Drawing	Pins	Package Qty	Eco Plan (2)	Lead finish/ Ball material (6)	MSL Peak Temp (3)	Op Temp (°C)	Device Marking (4/5)	Samples
TPIC1021D	NRND	SOIC	D	8	75	RoHS & Green	NIPDAU	Level-1-260C-UNLIM	-40 to 125	T1021	
TPIC1021DG4	NRND	SOIC	D	8	75	RoHS & Green	NIPDAU	Level-1-260C-UNLIM		T1021	
TPIC1021DR	NRND	SOIC	D	8	2500	RoHS & Green	NIPDAU	Level-1-260C-UNLIM	-40 to 125	T1021	
TPIC1021DRG4	NRND	SOIC	D	8	2500	RoHS & Green	NIPDAU	Level-1-260C-UNLIM		T1021	

(1) The marketing status values are defined as follows:

ACTIVE: Product device recommended for new designs.

LIFEBUY: TI has announced that the device will be discontinued, and a lifetime-buy period is in effect.

NRND: Not recommended for new designs. Device is in production to support existing customers, but TI does not recommend using this part in a new design.

PREVIEW: Device has been announced but is not in production. Samples may or may not be available.

OBSOLETE: TI has discontinued the production of the device.

(2) **RoHS:** TI defines "RoHS" to mean semiconductor products that are compliant with the current EU RoHS requirements for all 10 RoHS substances, including the requirement that RoHS substance do not exceed 0.1% by weight in homogeneous materials. Where designed to be soldered at high temperatures, "RoHS" products are suitable for use in specified lead-free processes. TI may reference these types of products as "Pb-Free".

RoHS Exempt: TI defines "RoHS Exempt" to mean products that contain lead but are compliant with EU RoHS pursuant to a specific EU RoHS exemption.

Green: TI defines "Green" to mean the content of Chlorine (Cl) and Bromine (Br) based flame retardants meet JS709B low halogen requirements of <=1000ppm threshold. Antimony trioxide based flame retardants must also meet the <=1000ppm threshold requirement.

(3) **MSL, Peak Temp.** - The Moisture Sensitivity Level rating according to the JEDEC industry standard classifications, and peak solder temperature.

(4) There may be additional marking, which relates to the logo, the lot trace code information, or the environmental category on the device.

(5) Multiple Device Markings will be inside parentheses. Only one Device Marking contained in parentheses and separated by a "~" will appear on a device. If a line is indented then it is a continuation of the previous line and the two combined represent the entire Device Marking for that device.

(6) **Lead finish/Ball material** - Orderable Devices may have multiple material finish options. Finish options are separated by a vertical ruled line. Lead finish/Ball material values may wrap to two lines if the finish value exceeds the maximum column width.

Important Information and Disclaimer:The information provided on this page represents TI's knowledge and belief as of the date that it is provided. TI bases its knowledge and belief on information provided by third parties, and makes no representation or warranty as to the accuracy of such information. Efforts are underway to better integrate information from third parties. TI has taken and continues to take reasonable steps to provide representative and accurate information but may not have conducted destructive testing or chemical analysis on incoming materials and chemicals. TI and TI suppliers consider certain information to be proprietary, and thus CAS numbers and other limited information may not be available for release.

In no event shall TI's liability arising out of such information exceed the total purchase price of the TI part(s) at issue in this document sold by TI to Customer on an annual basis.

TAPE AND REEL INFORMATION

QUADRANT ASSIGNMENTS FOR PIN 1 ORIENTATION IN TAPE

*All dimensions are nominal

Device	Package Type	Package Drawing	Pins	SPQ	Reel Diameter (mm)	Reel Width W1 (mm)	A0 (mm)	B0 (mm)	K0 (mm)	P1 (mm)	W (mm)	Pin1 Quadrant
TPIC1021DR	SOIC	D	8	2500	330.0	12.4	6.4	5.2	2.1	8.0	12.0	Q1
TPIC1021DRG4	SOIC	D	8	2500	330.0	12.4	6.4	5.2	2.1	8.0	12.0	Q1

TAPE AND REEL BOX DIMENSIONS

*All dimensions are nominal

Device	Package Type	Package Drawing	Pins	SPQ	Length (mm)	Width (mm)	Height (mm)
TPIC1021DR	SOIC	D	8	2500	356.0	356.0	35.0
TPIC1021DRG4	SOIC	D	8	2500	356.0	356.0	35.0

TUBE

*All dimensions are nominal

Device	Package Name	Package Type	Pins	SPQ	L (mm)	W (mm)	T (μm)	B (mm)
TPIC1021D	D	SOIC	8	75	505.46	6.76	3810	4
TPIC1021D	D	SOIC	8	75	506.6	8	3940	4.32
TPIC1021DG4	D	SOIC	8	75	506.6	8	3940	4.32
TPIC1021DG4	D	SOIC	8	75	505.46	6.76	3810	4



D0008A

PACKAGE OUTLINE

SOIC - 1.75 mm max height

SMALL OUTLINE INTEGRATED CIRCUIT



4214825/C 02/2019

NOTES:

1. Linear dimensions are in inches [millimeters]. Dimensions in parenthesis are for reference only. Controlling dimensions are in inches. Dimensioning and tolerancing per ASME Y14.5M.
2. This drawing is subject to change without notice.
3. This dimension does not include mold flash, protrusions, or gate burrs. Mold flash, protrusions, or gate burrs shall not exceed $.006$ [0.15] per side.
4. This dimension does not include interlead flash.
5. Reference JEDEC registration MS-012, variation AA.

EXAMPLE BOARD LAYOUT

D0008A

SOIC - 1.75 mm max height

SMALL OUTLINE INTEGRATED CIRCUIT



LAND PATTERN EXAMPLE
 EXPOSED METAL SHOWN
 SCALE:8X



SOLDER MASK DETAILS

4214825/C 02/2019

NOTES: (continued)

- 6. Publication IPC-7351 may have alternate designs.
- 7. Solder mask tolerances between and around signal pads can vary based on board fabrication site.

EXAMPLE STENCIL DESIGN

D0008A

SOIC - 1.75 mm max height

SMALL OUTLINE INTEGRATED CIRCUIT



SOLDER PASTE EXAMPLE
BASED ON .005 INCH [0.125 MM] THICK STENCIL
SCALE:8X

4214825/C 02/2019

NOTES: (continued)

8. Laser cutting apertures with trapezoidal walls and rounded corners may offer better paste release. IPC-7525 may have alternate design recommendations.
9. Board assembly site may have different recommendations for stencil design.

重要声明和免责声明

TI“按原样”提供技术和可靠性数据（包括数据表）、设计资源（包括参考设计）、应用或其他设计建议、网络工具、安全信息和其他资源，不保证没有瑕疵且不做任何明示或暗示的担保，包括但不限于对适销性、某特定用途方面的适用性或不侵犯任何第三方知识产权的暗示担保。

这些资源可供使用 TI 产品进行设计的熟练开发人员使用。您将自行承担以下全部责任：(1) 针对您的应用选择合适的 TI 产品，(2) 设计、验证并测试您的应用，(3) 确保您的应用满足相应标准以及任何其他功能安全、信息安全、监管或其他要求。

这些资源如有变更，恕不另行通知。TI 授权您仅可将这些资源用于研发本资源所述的 TI 产品的应用。严禁对这些资源进行其他复制或展示。您无权使用任何其他 TI 知识产权或任何第三方知识产权。您应全额赔偿因在这些资源的使用中对 TI 及其代表造成的任何索赔、损害、成本、损失和债务，TI 对此概不负责。

TI 提供的产品受 [TI 的销售条款](#) 或 [ti.com](#) 上其他适用条款/TI 产品随附的其他适用条款的约束。TI 提供这些资源并不会扩展或以其他方式更改 TI 针对 TI 产品发布的适用的担保或担保免责声明。

TI 反对并拒绝您可能提出的任何其他或不同的条款。

邮寄地址：Texas Instruments, Post Office Box 655303, Dallas, Texas 75265

Copyright © 2022，德州仪器 (TI) 公司