

限流配电开关

特性

- 单一电源开关系列产品
- 与现有的德州仪器 (TI) 系列产品引脚到引脚对应
- **0.5A, 1A, 1.5A, 2A** 的额定电流
- **±20%** 精确、固定、恒定电流限制
- 快速过流响应时间为 **-2ns**
- 去尖峰脉冲故障报告
- 已选择具有 (TPS20xxC) 和没有 (TPS20xxC-2) 输出放电的部件
- 反向电流阻断
- 内置软启动
- 环境温度范围: **-40°C 至 85°C**
- 经 **UL** 检测和认证以及 **CB** 认证-文件号**E169910**

应用范围

- **USB** 端口/集线器、笔记本、台式机
- 高清数字电视
- 机顶盒
- 短路保护功能

说明

TPS20xxC 和 TPS20xxC-2 配电开关系列产品用于诸如 USB 等有可能遇到高电容负载和短路的应用。这一系列产品为电流介于 0.5A 和 2A 之间的应用提供具有固定电流限值阈值的多种器件。

当输出负载超过电流限值阈值时, TPS20xxC 和 TPS20xxC-2 通过运行在恒定电流模式下来将输出电流限制在安全的水平上。这就在所有条件下提供了一个可预计的故障电流。当输出被短接时, 快速过载响应时间减轻了主 5V 电源提供稳压电源的负担。为了大大减少打开和关闭期间的电流冲击, 电源开关的上升和下降次数受到控制。



图 1. 典型应用

中删除了注释 2
表 1. 器件⁽¹⁾

最大运行 电流	器件	状态		
		MSOP-8 (PowerPad™) 封装	小外形尺寸晶体管 (SOT) 23-5	MSOP-8
0.5	TPS2041C 和 51C	—	激活和激活	—
1	TPS2061C 和 65C	激活和激活	激活和激活	—
1	TPS2065C-2	激活	激活	—
1.5	TPS2068C 和 69C	激活和激活	— 和激活	—
1.5	TPS2069C-2	激活	—	—
2	TPS2000C 和 01C	激活和激活	—	激活和激活

(1) 要获得更多细节, 请见此器件信息表。

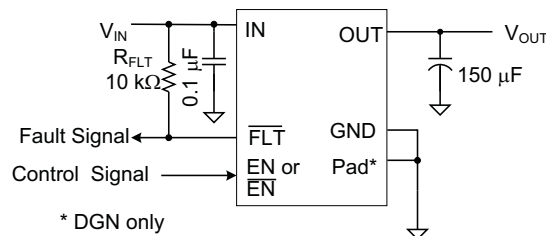
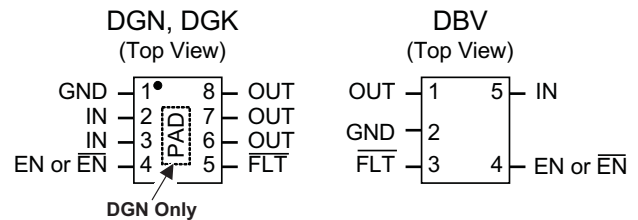

Please be aware that an important notice concerning availability, standard warranty, and use in critical applications of Texas Instruments semiconductor products and disclaimers thereto appears at the end of this data sheet.

PowerPad is a trademark of Texas Instruments.

TPS20xxC, TPS20xxC-2

ZHCS443G – JUNE 2011 – REVISED JULY 2013

www.ti.com.cn



This integrated circuit can be damaged by ESD. Texas Instruments recommends that all integrated circuits be handled with appropriate precautions. Failure to observe proper handling and installation procedures can cause damage.

ESD damage can range from subtle performance degradation to complete device failure. Precision integrated circuits may be more susceptible to damage because very small parametric changes could cause the device not to meet its published specifications.

DEVICE INFORMATION⁽¹⁾

MAXIMUM OPERATING CURRENT	OUTPUT DISCHARGE	ENABLE	BASE PART NUMBER	PACKAGED DEVICE AND MARKING ⁽²⁾		
				MSOP-8 (DGN) PowerPAD™	SOT23-5 (DBV)	MSOP-8 (DGK)
0.5	Y	Low	TPS2041C	–	PYJI	–
0.5	Y	High	TPS2051C	–	VBYQ	–
1	Y	Low	TPS2061C	PXMI	PXLI	–
1	Y	High	TPS2065C	VCAQ	VCAQ	–
1	N	High	TPS2065C-2	PYRI	PYQI	–
1.5	Y	Low	TPS2068C	PXNI	–	–
1.5	Y	High	TPS2069C	VBUQ	PYKI	–
1.5	N	High	TPS2069C-2	PYSI	–	–
2	Y	Low	TPS2000C	BCMS	–	PXFI
2	Y	High	TPS2001C	VBWQ	–	PXGI

(1) For the most current packaging and ordering information, see the Package Option Addendum at the end of this document, or see the TI website at www.ti.com.

(2) "-" indicates the device is not available in this package.

ABSOLUTE MAXIMUM RATINGS⁽¹⁾⁽²⁾

	VALUE		UNIT
	MIN	MAX	
Voltage range on IN, OUT, EN or \overline{EN} , \overline{FLT} ⁽³⁾	-0.3	6	V
Voltage range from IN to OUT	-6	6	V
Maximum junction temperature, T _J	Internally Limited		
Electrostatic Discharge	HBM	2	kV
	CDM	500	V
	IEC 61000-4-2, Contact / Air ⁽⁴⁾	8	15

(1) Absolute maximum ratings apply over recommended junction temperature range.

(2) Voltages are with respect to GND unless otherwise noted.

(3) See the [Input and Output Capacitance](#) section.

(4) V_{OUT} was surged on a pcb with input and output bypassing per [Figure 1](#) (except input capacitor was 22 μF) with no device failures.

THERMAL INFORMATION

THERMAL METRIC ⁽¹⁾ (See DEVICE INFORMATION table.)	0.5 A or 1 A Rated	1.5 A or 2 A Rated	0.5 A or 1 A Rated	1.5 A or 2 A Rated	2 A Rated	UNITS
	DBV	DBV	DGN	DGN	DGK	
	5 PINS	5 PINS	8 PINS	8 PINS	8 PINS	
θ _{JA} Junction-to-ambient thermal resistance	224.9	220.4	72.1	67.1	205.5	°C/W
θ _{JCtop} Junction-to-case (top) thermal resistance	95.2	89.7	87.3	80.8	94.3	
θ _{JB} Junction-to-board thermal resistance	51.4	46.9	42.2	37.2	126.9	
ψ _{JT} Junction-to-top characterization parameter	6.6	5.2	7.3	5.6	24.7	
ψ _{JB} Junction-to-board characterization parameter	50.3	46.2	42.0	36.9	125.2	
θ _{JCbot} Junction-to-case (bottom) thermal resistance	N/A	N/A	39.2	32.1	N/A	
θ _{JA} Custom See the Power Dissipation and Junction Temperature section	139.3	134.9	66.5	61.3	110.3	

(1) For more information about traditional and new thermal metrics, see the *IC Package Thermal Metrics* application report, [SPRA953](#).

RECOMMENDED OPERATING CONDITIONS

		MIN	NOM	MAX	UNIT
V_{IN}	Input voltage, IN	4.5		5.5	V
V_{EN}	Input voltage, EN or \overline{EN}	0		5.5	V
V_{IH}	High-level input voltage, EN or \overline{EN}	2			V
V_{IL}	Low-level input voltage, EN or \overline{EN}			0.7	V
I_{OUT}	Continuous output current, $I_{OUT}^{(1)}$	TPS2041C and TPS2051C		0.5	A
		TPS2061C, TPS2065C and TPS2065C-2		1	
		TPS2068C, TPS2069C and TPS2069C-2		1.5	
		TPS2000C and TPS2001C		2	
T_J	Operating junction temperature	-40		125	°C
I_{FLT}	Sink current into \overline{FLT}	0		5	mA

(1) Some package and current rating may request an ambient temperature derating of 85°C.

ELECTRICAL CHARACTERISTICS: $T_J = T_A = 25^\circ\text{C}^{(1)}$

Unless otherwise noted:, $V_{IN} = 5\text{ V}$, $V_{EN} = V_{IN}$ or $V_{\overline{EN}} = \text{GND}$, $I_{OUT} = 0\text{ A}$. See the 'Device Information' table for the rated current of each part number. Parametrics over a wider operational range are shown in the second 'Electrical Characteristics' table.

PARAMETER		TEST CONDITIONS ⁽¹⁾		MIN	TYP	MAX	UNIT
POWER SWITCH							
$R_{DS(on)}$	Input – output resistance	0.5 A rated output, 25°C	DBV		97	110	mΩ
		0.5 A rated output, -40°C ≤ (T _J , T _A) ≤ 85°C	DBV		96	130	mΩ
		1 A rated output, 25°C	DBV		96	110	mΩ
			DGN		86	100	
		1 A rated output, -40°C ≤ (T _J , T _A) ≤ 85°C	DBV		96	130	mΩ
			DGN		86	120	
		1.5 A rated output, 25°C	DBV		76	91	mΩ
			DGN		69	84	
		1.5 A rated output, -40°C ≤ (T _J , T _A) ≤ 85°C	DBV		76	106	mΩ
			DGN		69	98	
2 A rated output, 25°C	DGN, DGK		72	84	mΩ		
2 A rated output, -40°C ≤ (T _J , T _A) ≤ 85°C	DGN, DGK		72	98	mΩ		
CURRENT LIMIT							
$I_{OS}^{(2)}$	Current-limit, See Figure 7	0.5A rated output	TPS20xxC	0.67	0.85	1.01	A
		1 A rated output	TPS20xxC	1.3	1.55	1.8	
			TPS20xxC-2	1.18	1.53	1.88	
		1.5 A rated output	TPS20xxC	1.7	2.15	2.5	
			TPS20xxC-2	1.71	2.23	2.75	
2 A rated output	TPS20xxC	2.35	2.9	3.4			
SUPPLY CURRENT							
I_{SD}	Supply current, switch disabled	$I_{OUT} = 0\text{ A}$			0.01	1	μA
		-40°C ≤ (T _J , T _A) ≤ 85°C, $V_{IN} = 5.5\text{ V}$, $I_{OUT} = 0\text{ A}$				2	
I_{SE}	Supply current, switch enabled	$I_{OUT} = 0\text{ A}$			60	70	μA
		-40°C ≤ (T _J , T _A) ≤ 85°C, $V_{IN} = 5.5\text{ V}$, $I_{OUT} = 0\text{ A}$				85	
I_{lkg}	Leakage current	$V_{OUT} = 0\text{ V}$, $V_{IN} = 5\text{ V}$, disabled, measure I_{VIN}	TPS20xxC-2		0.05	1	μA
		-40°C ≤ (T _J , T _A) ≤ 85°C, $V_{OUT} = 0\text{ V}$, $V_{IN} = 5\text{ V}$, disabled, measure I_{VIN}				2	

(1) Pulsed testing techniques maintain junction temperature approximately equal to ambient temperature

(2) See **CURRENT LIMIT** section for explanation of this parameter.

TPS20xxC, TPS20xxC-2

ZHCS443G – JUNE 2011 – REVISED JULY 2013

www.ti.com.cn

ELECTRICAL CHARACTERISTICS: $T_J = T_A = 25^\circ\text{C}^{(1)}$ (continued)

Unless otherwise noted: $V_{IN} = 5\text{ V}$, $V_{EN} = V_{IN}$ or $\overline{V_{EN}} = \text{GND}$, $I_{OUT} = 0\text{ A}$. See the 'Device Information' table for the rated current of each part number. Parametrics over a wider operational range are shown in the second 'Electrical Characteristics' table.

PARAMETER	TEST CONDITIONS ⁽¹⁾	MIN	TYP	MAX	UNIT	
I_{REV} Reverse leakage current	$V_{OUT} = 5\text{ V}$, $V_{IN} = 0\text{ V}$, measure I_{VOUT}		0.1	1	μA	
	$-40^\circ\text{C} \leq (T_J, T_A) \leq 85^\circ\text{C}$, $V_{OUT} = 5\text{ V}$, $V_{IN} = 0\text{ V}$, measure I_{VOUT}			5		
OUTPUT DISCHARGE						
R_{PD} Output pull-down resistance ⁽³⁾	$V_{IN} = V_{OUT} = 5\text{ V}$, disabled	TPS20xxC	400	470	600	Ω

(3) These parameters are provided for reference only, and do not constitute part of TI's published device specifications for purposes of TI's product warranty.

ELECTRICAL CHARACTERISTICS: $-40^\circ\text{C} \leq T_J \leq 125^\circ\text{C}$

Unless otherwise noted: $4.5\text{ V} \leq V_{IN} \leq 5.5\text{ V}$, $V_{EN} = V_{IN}$ or $\overline{V_{EN}} = \text{GND}$, $I_{OUT} = 0\text{ A}$, typical values are at 5 V and 25°C . See the DEVICE INFORMATION table for the rated current of each part number.

PARAMETER	TEST CONDITIONS ⁽¹⁾	MIN	TYP	MAX	UNIT	
POWER SWITCH						
$R_{DS(ON)}$ Input – output resistance	0.5 A rated output	DBV	97	154	$\text{m}\Omega$	
	1 A rated output	DBV	96	154		
		DGN	86	140		
	1.5 A rated output	DBV	76	121	$\text{m}\Omega$	
		DGN	69	112	$\text{m}\Omega$	
2 A rated output	DGN, DGK	72	112	$\text{m}\Omega$		
ENABLE INPUT (EN or $\overline{\text{EN}}$)						
Threshold	Input rising	1	1.45	2	V	
Hysteresis		0.07	0.13	0.20	V	
Leakage current	$(V_{EN} \text{ or } \overline{V_{EN}}) = 0\text{ V or } 5.5\text{ V}$	-1	0	1	μA	
t_{ON} Turnon time	$V_{IN} = 5\text{ V}$, $C_L = 1\text{ }\mu\text{F}$, $R_L = 100\text{ }\Omega$, EN \uparrow or $\overline{\text{EN}}$ \downarrow . See Figure 2 , Figure 4 , and Figure 5				ms	
	0.5A / 1A Rated	1	1.4	1.8		
	1.5A / 2A Rated	1.2	1.7	2.2		
t_{OFF} Turnoff time	$V_{IN} = 5\text{ V}$, $C_L = 1\text{ }\mu\text{F}$, $R_L = 100\text{ }\Omega$, EN \downarrow or $\overline{\text{EN}}$ \uparrow . See Figure 2 , Figure 4 , and Figure 5				ms	
	0.5A and 1A Rated	1.3	1.65	2		
	1.5A / 2A Rated	1.7	2.1	2.5		
t_R Rise time, output	$C_L = 1\text{ }\mu\text{F}$, $R_L = 100\text{ }\Omega$, $V_{IN} = 5\text{ V}$. See Figure 3				ms	
	0.5A / 1A Rated	0.4	0.55	0.7		
	1.5A / 2A Rated	0.5	0.7	1.0		
t_F Fall time, output	$C_L = 1\text{ }\mu\text{F}$, $R_L = 100\text{ }\Omega$, $V_{IN} = 5\text{ V}$. See Figure 3				ms	
	0.5A / 1A Rated	0.25	0.35	0.45		
	1.5A / 2A Rated	0.3	0.43	0.55		
CURRENT LIMIT						
$I_{OS}^{(2)}$ Current-limit, See Figure 10	0.5 A rated output	TPS20xxC	0.65	0.85	1.05	A
	1 A rated output	TPS20xxC	1.2	1.55	1.9	
		TPS20xxC-2	1.1	1.53	1.96	
	1.5 A rated output	TPS20xxC	1.6	2.15	2.7	
		TPS20xxC-2	1.6	2.23	2.86	
2 A rated output	TPS20xxC	2.3	2.9	3.6		

(1) Pulsed testing techniques maintain junction temperature approximately equal to ambient temperature

(2) See [CURRENT LIMIT](#) section for explanation of this parameter.

ELECTRICAL CHARACTERISTICS: $-40^{\circ}\text{C} \leq T_J \leq 125^{\circ}\text{C}$ (continued)

Unless otherwise noted: $4.5\text{ V} \leq V_{IN} \leq 5.5\text{ V}$, $V_{EN} = V_{IN}$ or $V_{\overline{EN}} = \text{GND}$, $I_{OUT} = 0\text{ A}$, typical values are at 5 V and 25°C . See the DEVICE INFORMATION table for the rated current of each part number.

PARAMETER	TEST CONDITIONS ⁽¹⁾	MIN	TYP	MAX	UNIT	
t_{IOS} Short-circuit response time ⁽³⁾	$V_{IN} = 5\text{ V}$ (see Figure 7), One-half full load $\rightarrow R_{SHORT} = 50\text{ m}\Omega$, Measure from application to when current falls below 120% of final value		2		μs	
SUPPLY CURRENT						
I_{SD} Supply current, switch disabled	$I_{OUT} = 0\text{ A}$		0.01	10	μA	
I_{SE} Supply current, switch enabled	$I_{OUT} = 0\text{ A}$		65	90	μA	
I_{lkg} Leakage current	$V_{OUT} = 0\text{ V}$, $V_{IN} = 5\text{ V}$, disabled, measure I_{VIN}	TPS20XXC-2			μA	
I_{REV} Reverse leakage current	$V_{OUT} = 5.5\text{ V}$, $V_{IN} = 0\text{ V}$, measure I_{VOUT}		0.2	20	μA	
UNDERVOLTAGE LOCKOUT						
V_{UVLO} Rising threshold	$V_{IN}\uparrow$	3.5	3.75	4	V	
Hysteresis ⁽³⁾	$V_{IN}\downarrow$		0.14		V	
FLT						
Output low voltage, \overline{FLT}	$I_{\overline{FLT}} = 1\text{ mA}$			0.2	V	
Off-state leakage	$V_{\overline{FLT}} = 5.5\text{ V}$			1	μA	
$t_{\overline{FLT}}$ \overline{FLT} deglitch	\overline{FLT} assertion or deassertion deglitch	6	9	12	ms	
OUTPUT DISCHARGE						
R_{PD} Output pull-down resistance	$V_{IN} = 4\text{ V}$, $V_{OUT} = 5\text{ V}$, disabled	TPS20XXC	350	560	1200	Ω
	$V_{IN} = 5\text{ V}$, $V_{OUT} = 5\text{ V}$, disabled	TPS20XXC	300	470	800	
THERMAL SHUTDOWN						
Rising threshold (T_J)	In current limit		135		$^{\circ}\text{C}$	
	Not in current limit		155			
Hysteresis ⁽⁴⁾			20			

(3) These parameters are provided for reference only, and do not constitute part of TI's published device specifications for purposes of TI's product warranty.

(4) These parameters are provided for reference only, and do not constitute part of TI's published device specifications for purposes of TI's product warranty.

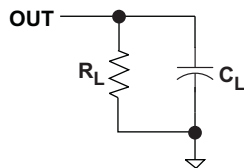

Figure 2. Output Rise / Fall Test Load

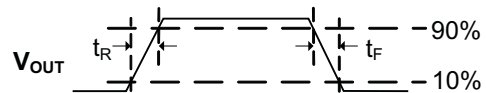

Figure 3. Power-On and Off Timing

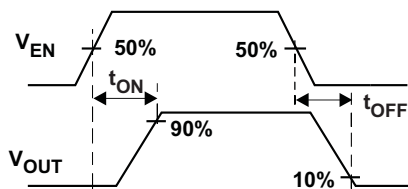

Figure 4. Enable Timing, Active High Enable

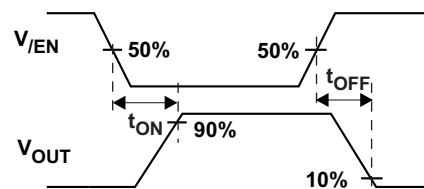

Figure 5. Enable Timing, Active Low Enable

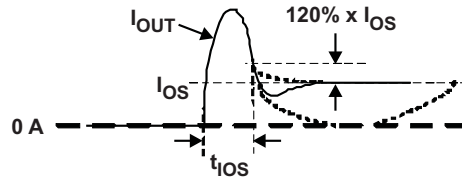

Figure 6. Output Short Circuit Parameters

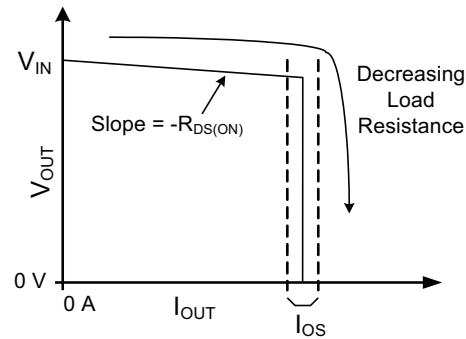

Figure 7. Output Characteristic Showing Current Limit

FUNCTIONAL BLOCK DIAGRAM

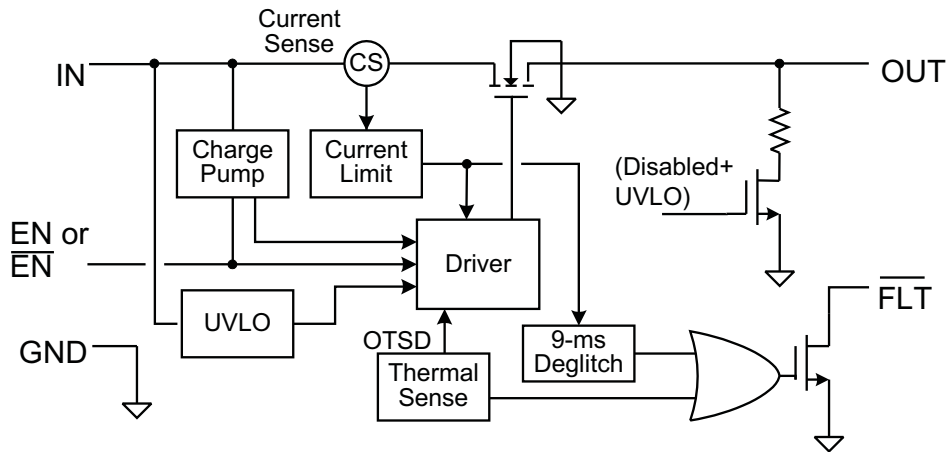

Figure 8. TPS20xxC Block Diagram

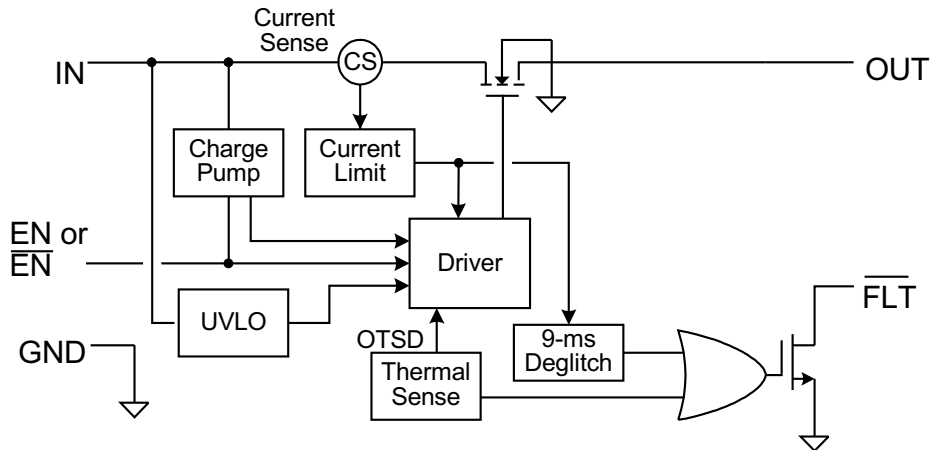

Figure 9. TPS20xxC-2 Block Diagram

DEVICE INFORMATION

PIN FUNCTIONS

NAME	PINS	DESCRIPTION
8-PIN PACKAGE		
EN or $\overline{\text{EN}}$	4	Enable input, logic high turns on power switch
GND	1	Ground connection
IN	2, 3	Input voltage and power-switch drain; connect a 0.1 μF or greater ceramic capacitor from IN to GND close to the IC
$\overline{\text{FLT}}$	5	Active-low open-drain output, asserted during over-current, or over-temperature conditions
OUT	6, 7, 8	Power-switch output, connect to load
PowerPAD (DGN ONLY)	PAD	Internally connected to GND. Connect PAD to GND plane as a heatsink for the best thermal performance. PAD may be left floating if desired. See POWER DISSIPATION AND JUNCTION TEMPERATURE section for guidance.
5-PIN PACKAGE		
EN or $\overline{\text{EN}}$	4	Enable input, logic high turns on power switch
GND	2	Ground connection
IN	5	Input voltage and power-switch drain; connect a 0.1 μF or greater ceramic capacitor from IN to GND close to the IC
$\overline{\text{FLT}}$	3	Active-low open-drain output, asserted during over-current, or over-temperature conditions
OUT	1	Power-switch output, connect to load.

TYPICAL CHARACTERISTICS

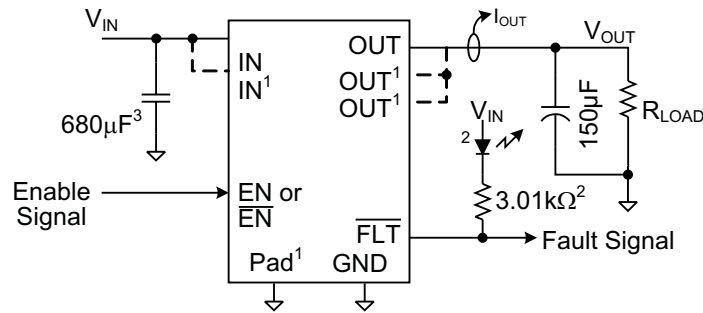

- (1) Not every package has all pins
- (2) These parts are for test purposes
- (3) Helps with output shorting tests when external supply is used.

Figure 10. Test Circuit for System Operation in Typical Characteristics Section

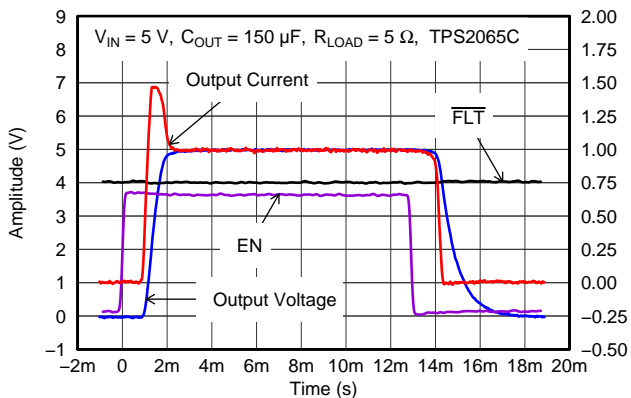

Figure 11. TPS2065C Output Rise / Fall 5Ω

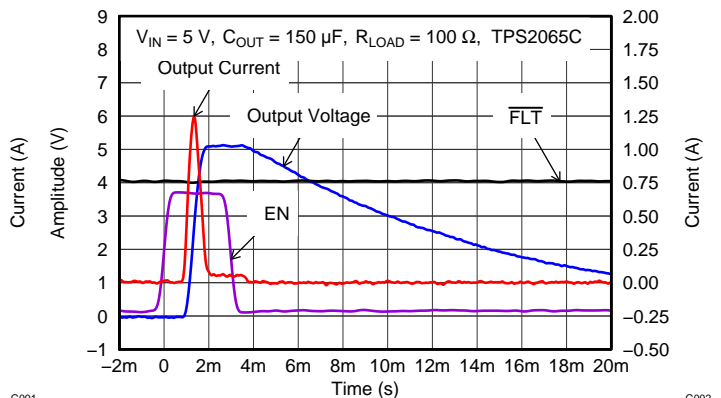

Figure 12. TPS2065C Output Rise / Fall 100Ω

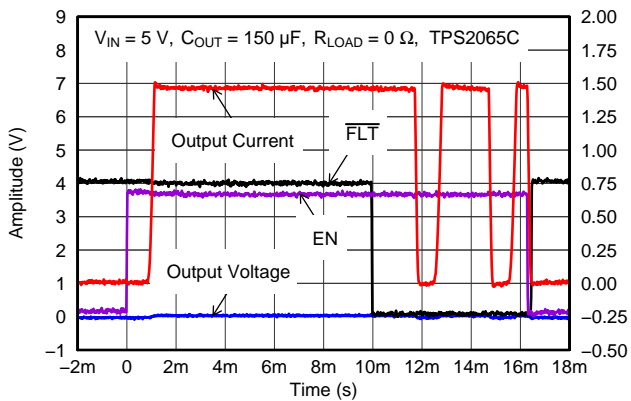

Figure 13. TPS2065C Enable into Output Short

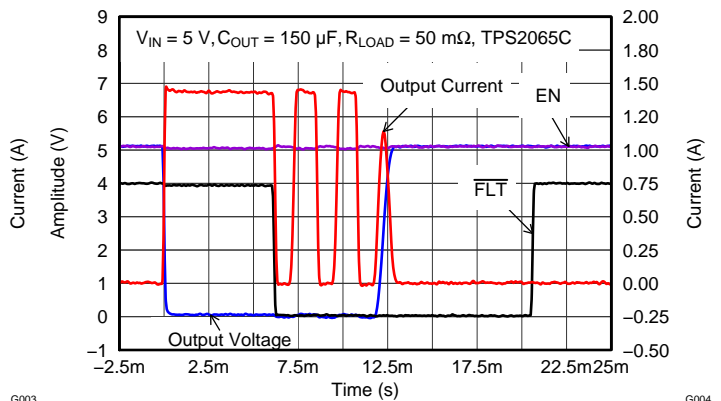

Figure 14. TPS2065C Pulsed Short Applied

TYPICAL CHARACTERISTICS (continued)

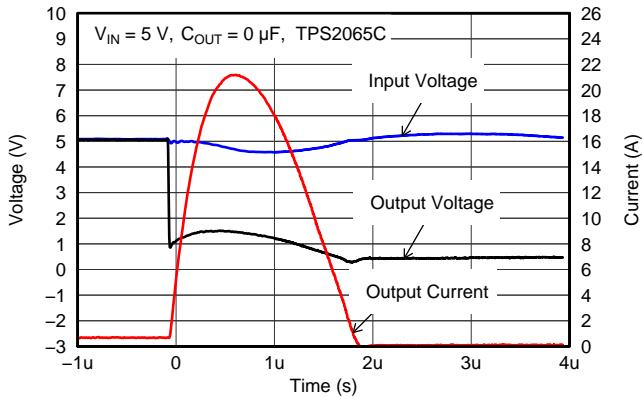

Figure 15. TPS2065C Short Applied

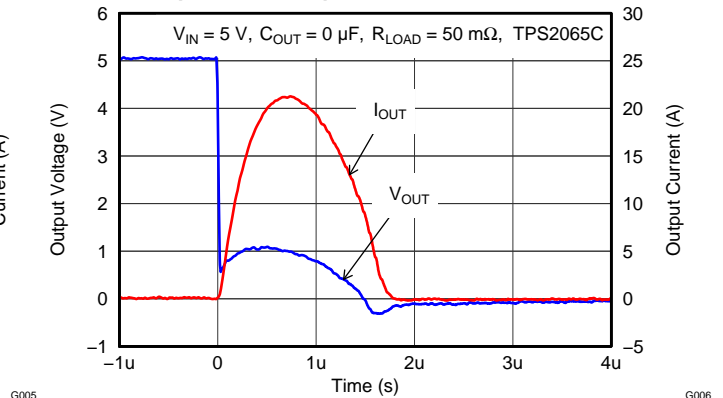

Figure 16. TPS2065C Pulsed 1.45-A Load

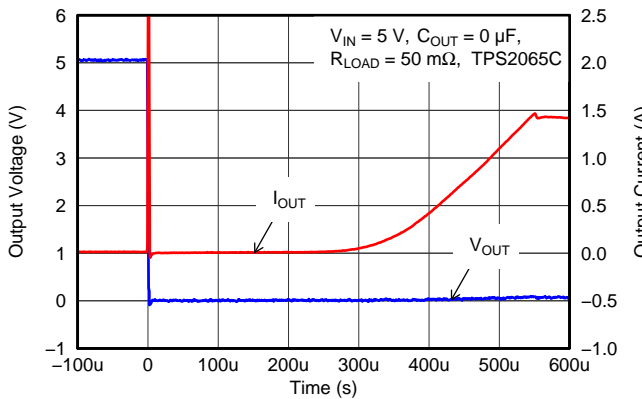

Figure 17. TPS2065C 50 mΩ Short Circuit

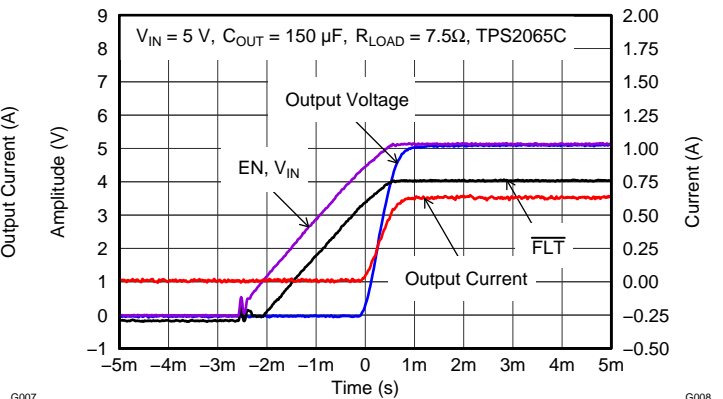

Figure 18. TPS2065C Power Up - Enabled

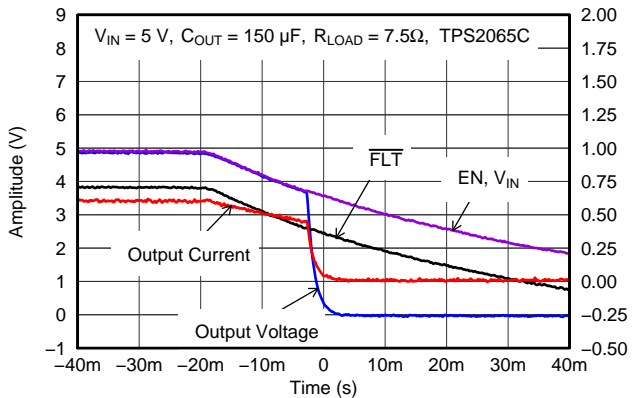

Figure 19. TPS2065C Power Down - Enabled

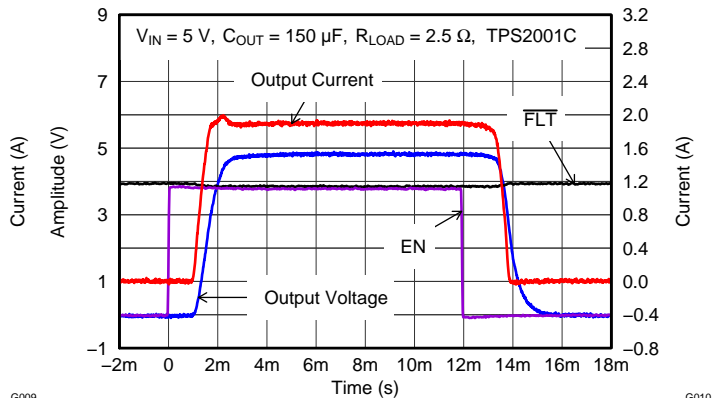

Figure 20. TPS2001C Turn ON into 2.5Ω

TYPICAL CHARACTERISTICS (continued)

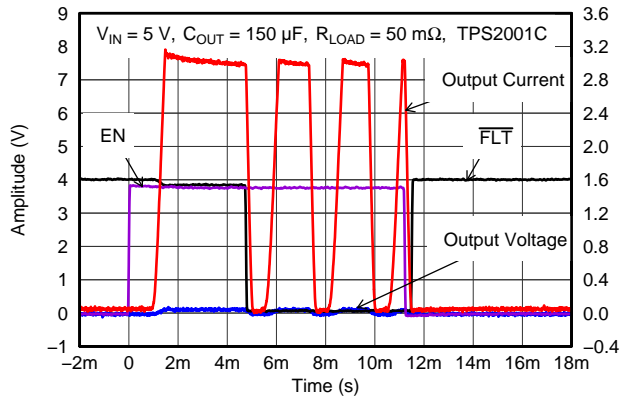

Figure 21. TPS2001C Enable into Short

G011

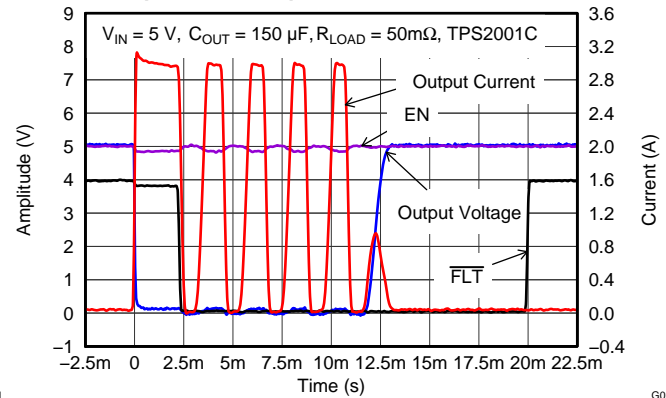

Figure 22. TPS2001C Pulsed Output Short

G012

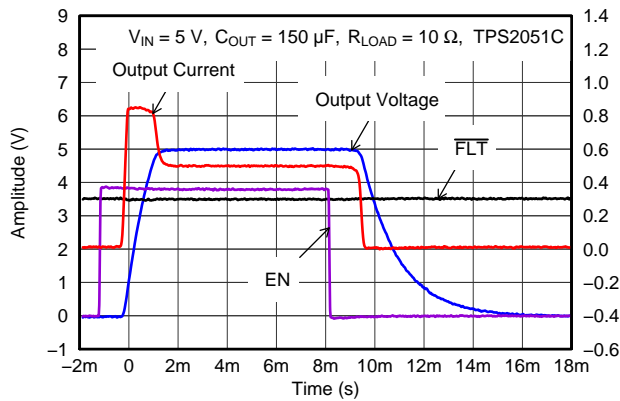

Figure 23. TPS2051C Turn ON into 10Ω

G013

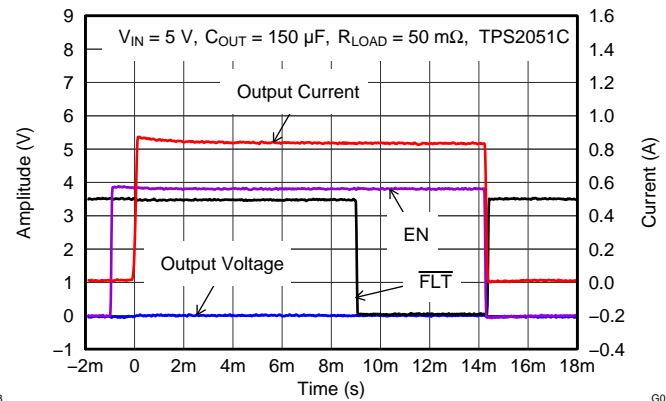

Figure 24. TPS2051C Enable into Short

G014

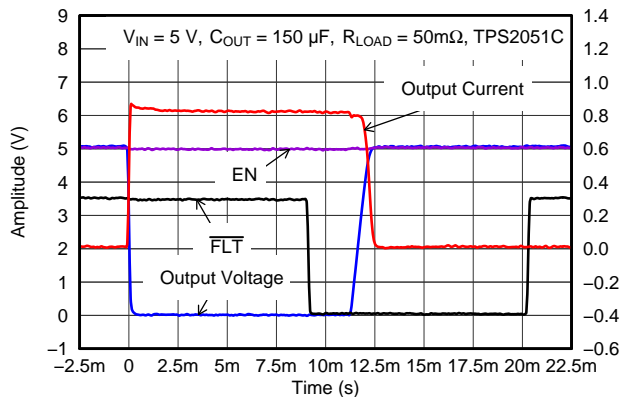

Figure 25. TPS2051C Pulsed Output Short

G015

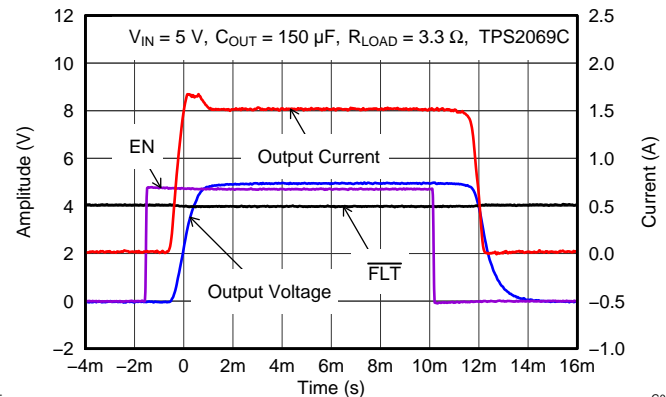

Figure 26. TPS2069C Turn ON into 3.3Ω

G016

TYPICAL CHARACTERISTICS (continued)

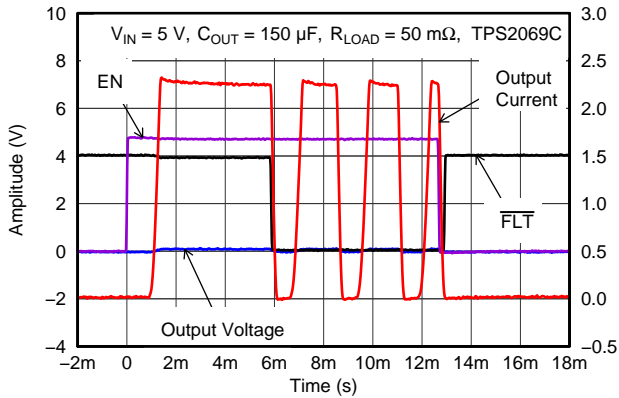

Figure 27. TPS2069C Enable into Short

G017

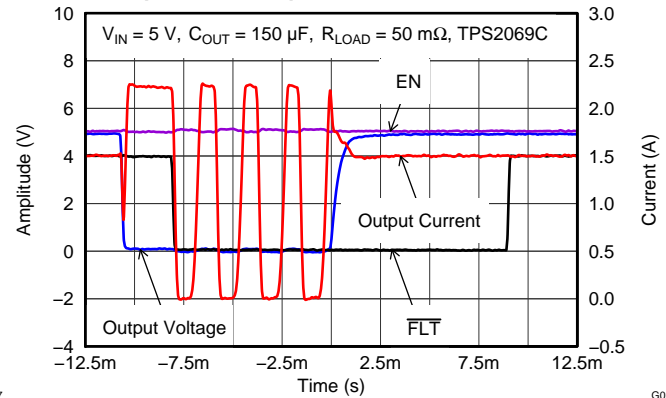

Figure 28. TPS2069C Pulsed Output Short

G018

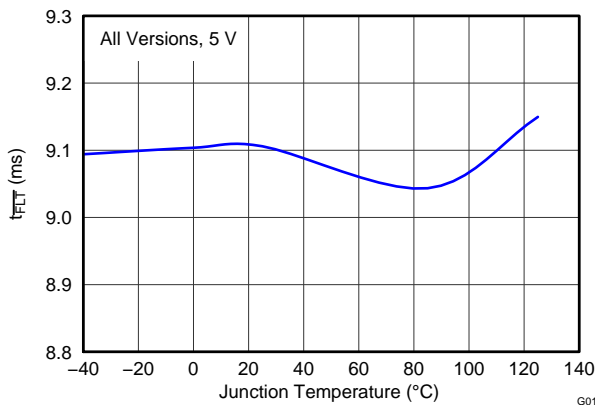

Figure 29. Deglitch Period (t_{FLT}) vs Temperature

G019

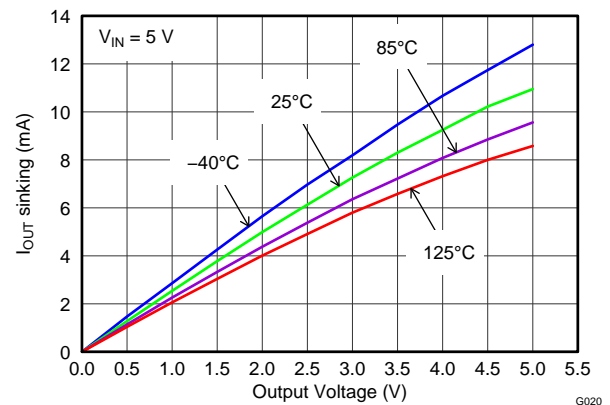

Figure 30. Output Discharge Current vs Output Voltage

G020

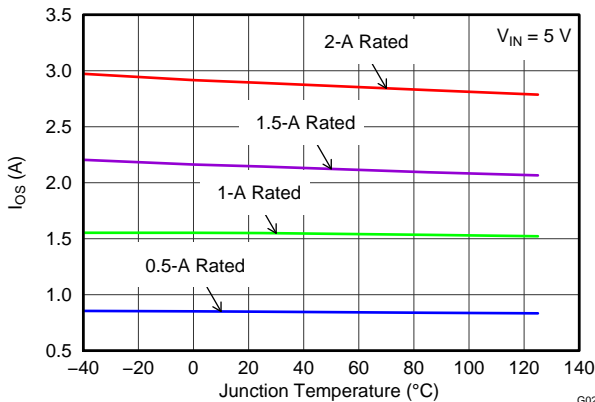

Figure 31. Short Circuit Current (I_{OS}) vs Temperature

G021

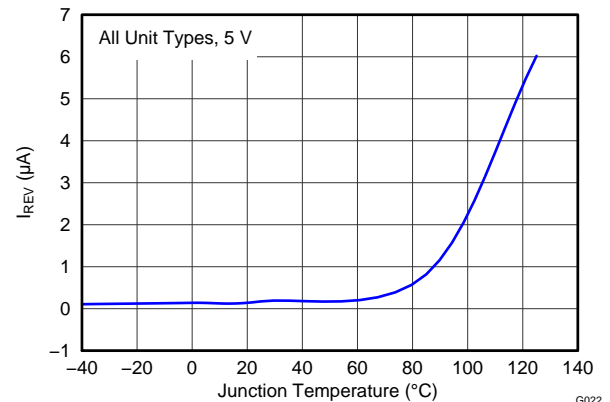

Figure 32. Reverse Leakage Current (I_{REV}) vs Temperature

G022

TYPICAL CHARACTERISTICS (continued)

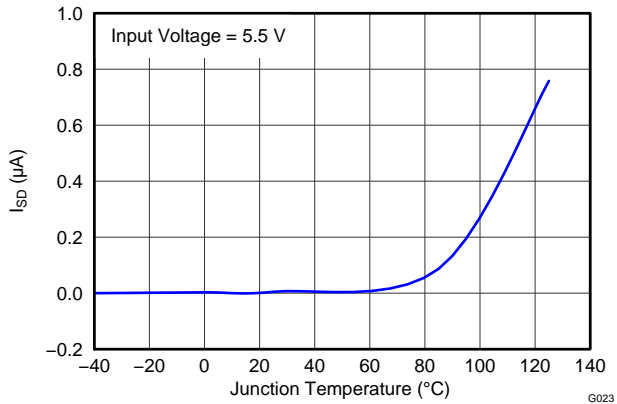

Figure 33. Disabled Supply Current (I_{SD}) vs Temperature

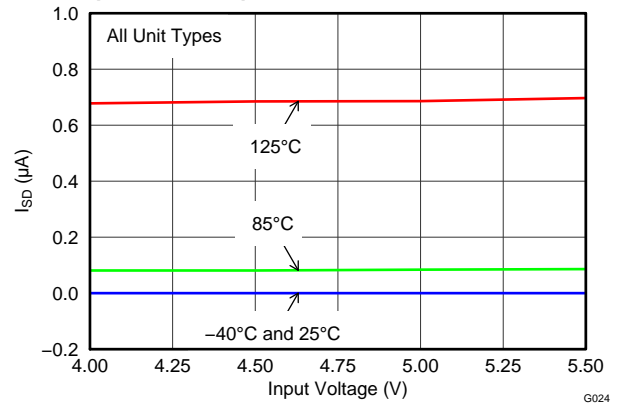

Figure 34. Disabled Supply Current (I_{SD}) vs Input Voltage

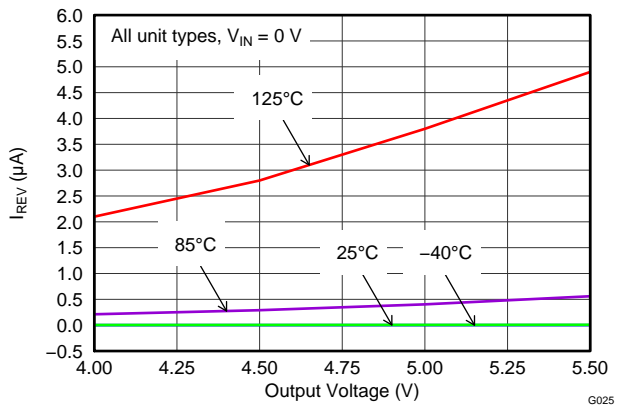

Figure 35. Reverse Leakage Current (I_{REV}) vs Output Voltage

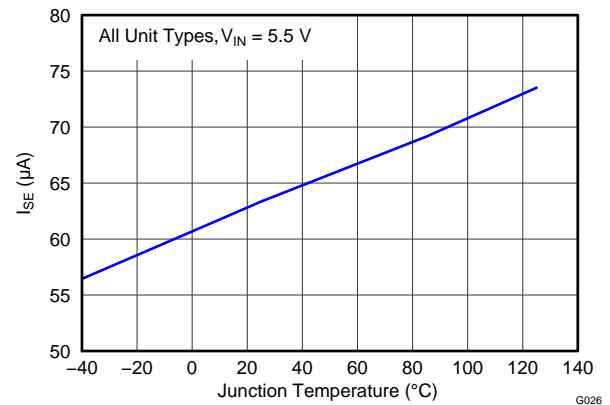

Figure 36. Enabled Supply Current (I_{SE}) vs Temperature

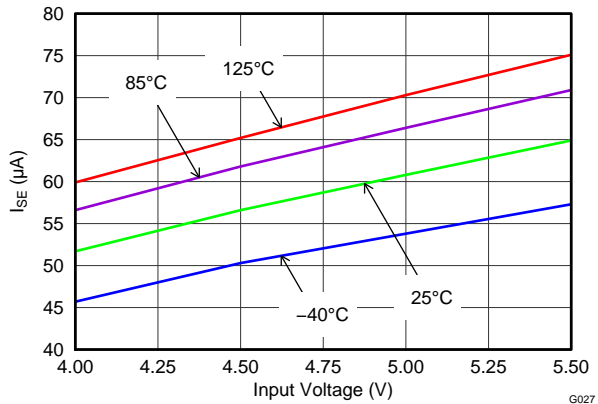

Figure 37. Enabled Supply Current (I_{SE}) vs Input Voltage

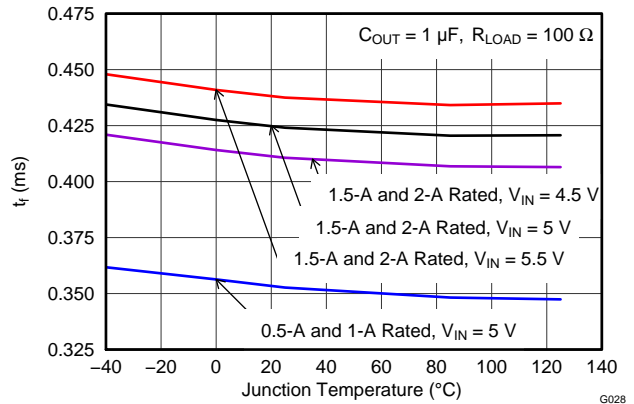

Figure 38. Output Fall Time (t_F) vs Temperature

TYPICAL CHARACTERISTICS (continued)

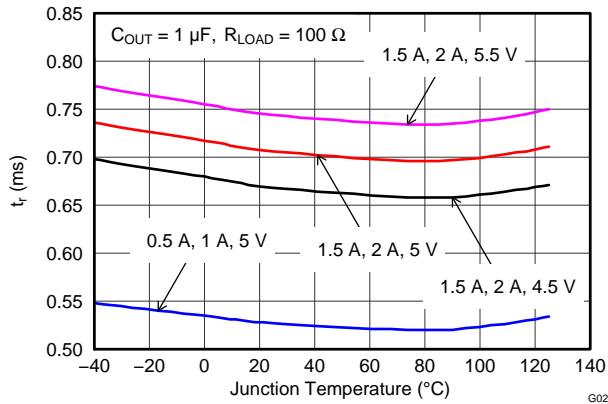

Figure 39. Output Rise Time (t_R) vs Temperature

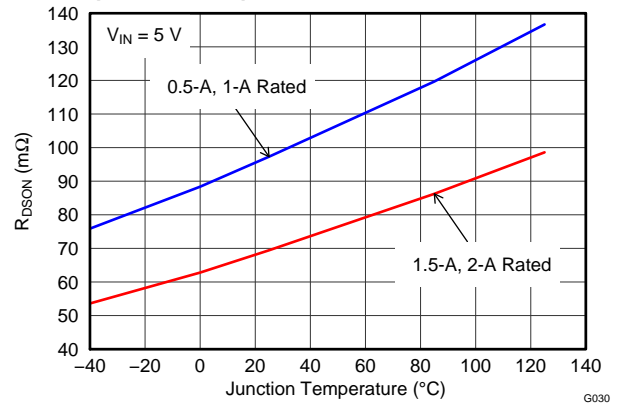

Figure 40. Input-Output Resistance ($R_{DS(ON)}$) vs Temperature

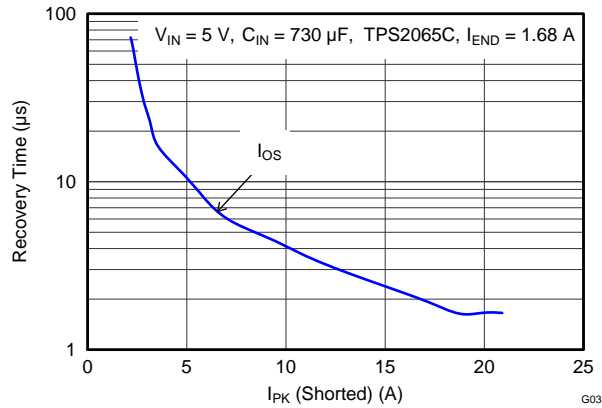

Figure 41. Recovery vs Current Peak

DETAILED DESCRIPTION

The TPS20xxC and TPS20xxC-2 are current-limited, power-distribution switches providing between 0.5 A and 2 A of continuous load current in 5 V circuits. These parts use N-channel MOSFETs for low resistance, maintaining voltage regulation to the load. They are designed for applications where short circuits or heavy capacitive loads will be encountered. Device features include enable, reverse blocking when disabled, output discharge pulldown, overcurrent protection, over-temperature protection, and deglitched fault reporting.

UVLO

The undervoltage lockout (UVLO) circuit disables the power switch until the input voltage reaches the UVLO turn-on threshold. Built-in hysteresis prevents unwanted on/off cycling due to input voltage drop from large current surges. FLT is high impedance when the TPS20xxC and TPS20xxC-2 are in UVLO.

ENABLE

The logic enable input (EN, or $\overline{\text{EN}}$), controls the power switch, bias for the charge pump, driver, and other circuits. The supply current is reduced to less than 1 μA when the TPS20xxC and TPS20xxC-2 are disabled. Disabling the TPS20xxC and TPS20xxC-2 will immediately clear an active $\overline{\text{FLT}}$ indication. The enable input is compatible with both TTL and CMOS logic levels.

The turnon and turnoff times (t_{ON} , t_{OFF}) are composed of a delay and a rise or fall time (t_{R} , t_{F}). The delay times are internally controlled. The rise time is controlled by both the TPS20xxC and TPS20xxC-2 and the external loading (especially capacitance). TPS20xxC fall time is controlled by the loading (R and C), and the output discharge (R_{PD}). TPS20xxC-2 does not have the output discharge (R_{PD}), fall time is controlled by the loading (R and C). An output load consisting of only a resistor will experience a fall time set by the TPS20xxC and TPS20xxC-2. An output load with parallel R and C elements will experience a fall time determined by the (R \times C) time constant if it is longer than the TPS20xxC and TPS20xxC-2's t_{F} .

The enable should not be left open, and may be tied to VIN or GND depending on the device.

INTERNAL CHARGE PUMP

The device incorporates an internal charge pump and gate drive circuitry necessary to drive the N-channel MOSFET. The charge pump supplies power to the gate driver circuit and provides the necessary voltage to pull the gate of the MOSFET above the source. The driver incorporates circuitry that controls the rise and fall times of the output voltage to limit large current and voltage surges on the input supply, and provides built-in soft-start functionality. The MOSFET power switch will block current from OUT to IN when turned off by the UVLO or disabled.

CURRENT LIMIT

The TPS20xxC and TPS20xxC-2 responds to overloads by limiting output current to the static I_{OS} levels shown in the Electrical Characteristics table. When an overload condition is present, the device maintains a constant output current, with the output voltage determined by ($I_{\text{OS}} \times R_{\text{LOAD}}$). Two possible overload conditions can occur.

The first overload condition occurs when either: 1) input voltage is first applied, enable is true, and a short circuit is present (load which draws $I_{\text{OUT}} > I_{\text{OS}}$), or 2) input voltage is present and the TPS20xxC and TPS20xxC-2 are enabled into a short circuit. The output voltage is held near zero potential with respect to ground and the TPS20xxC and TPS20xxC-2 ramps the output current to I_{OS} . The TPS20xxC and TPS20xxC-2 will limit the current to I_{OS} until the overload condition is removed or the device begins to thermal cycle. This is demonstrated in [Figure 13](#) where the device was enabled into a short, and subsequently cycles current off and on as the thermal protection engages.

The second condition is when an overload occurs while the device is enabled and fully turned on. The device responds to the overload condition within t_{IOS} ([Figure 6](#) and [Figure 7](#)) when the specified overload (per Electrical Characteristics table) is applied. The response speed and shape will vary with the overload level, input circuit, and rate of application. The current-limit response will vary between simply settling to I_{OS} , or turnoff and controlled return to I_{OS} . Similar to the previous case, the TPS20xxC and TPS20xxC-2 will limit the current to I_{OS} until the overload condition is removed or the device begins to thermal cycle. This is demonstrated by [Figure 14](#), [Figure 15](#), and [Figure 16](#).

The TPS20xxC and TPS20xxC-2 thermal cycles if an overload condition is present long enough to activate thermal limiting in any of the above cases. This is due to the relatively large power dissipation $[(V_{IN} - V_{OUT}) \times I_{OS}]$ driving the junction temperature up. The device turns off when the junction temperature exceeds 135°C (min) while in current limit. The device remains off until the junction temperature cools 20°C and then restarts.

There are two kinds of current limit profiles typically available in TI switch products similar to the TPS20xxC and TPS20xxC-2. Many older designs have an output I vs V characteristic similar to the plot labeled "Current Limit with Peaking" in Figure 42. This type of limiting can be characterized by two parameters, the current limit corner (I_{OC}), and the short circuit current (I_{OS}). I_{OC} is often specified as a maximum value. The TPS20xxC and TPS20xxC-2 family of parts does not present noticeable peaking in the current limit, corresponding to the characteristic labeled "Flat Current Limit" in Figure 42. This is why the I_{OC} parameter is not present in the Electrical Characteristics tables.

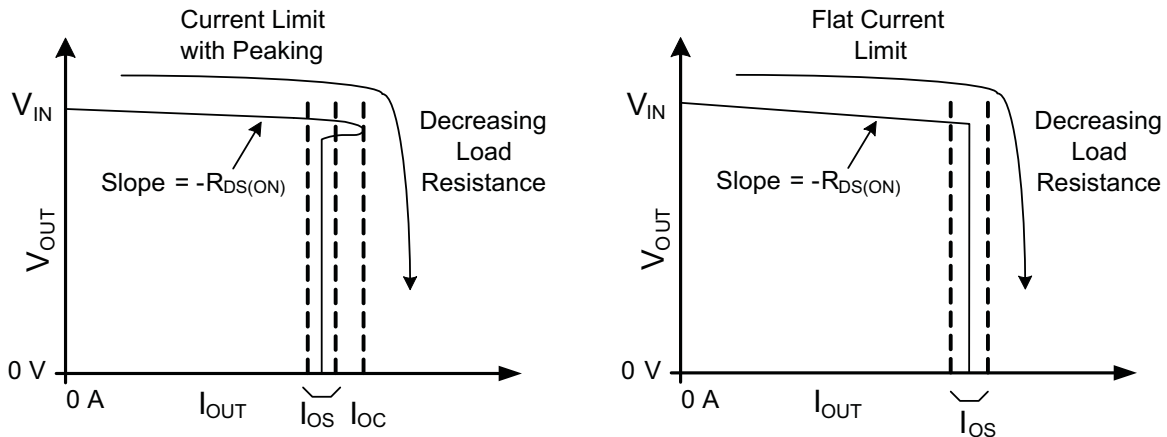

Figure 42. Current Limit Profiles

FLT

The \overline{FLT} open-drain output is asserted (active low) during an overload or over-temperature condition. A 9 ms deglitch on both the rising and falling edges avoids false reporting at startup and during transients. A current limit condition shorter than the deglitch period will clear the internal timer upon termination. The deglitch timer will not integrate multiple short overloads and declare a fault. This is also true for exiting from a faulted state. An input voltage with excessive ripple and large output capacitance may interfere with operation of \overline{FLT} around I_{OS} as the ripple will drive the TPS20xxC and TPS20xxC-2 in and out of current limit.

If the TPS20xxC and TPS20xxC-2 are in current limit and the over-temperature circuit goes active, \overline{FLT} will go true immediately (see Figure 14) however exiting this condition is deglitched (see Figure 16). \overline{FLT} is tripped just as the knee of the constant-current limiting is entered. Disabling the TPS20xxC and TPS20xxC-2 will clear an active \overline{FLT} as soon as the switch turns off (see Figure 13). \overline{FLT} is high impedance when the TPS20xxC and TPS20xxC-2 are disabled or in under-voltage lockout (UVLO).

OUTPUT DISCHARGE

A 470Ω (typical) output discharge will dissipate stored charge and leakage current on OUT when the TPS20xxC is in UVLO or disabled. The pull-down circuit will lose bias gradually as V_{IN} decreases, causing a rise in the discharge resistance as V_{IN} falls towards 0 V. The TPS20xxC-2 does not have this function. The output is be controlled by an external loadings when the device is in ULVO or disabled.

APPLICATION INFORMATION

INPUT AND OUTPUT CAPACITANCE

Input and output capacitance improves the performance of the device; the actual capacitance should be optimized for the particular application. For all applications, a 0.1 μF or greater ceramic bypass capacitor between IN and GND is recommended as close to the device as possible for local noise decoupling.

All protection circuits such as the TPS20xxC and TPS20xxC-2 will have the potential for input voltage overshoots and output voltage undershoots.

Input voltage overshoots can be caused by either of two effects. The first cause is an abrupt application of input voltage in conjunction with input power bus inductance and input capacitance when the IN terminal is high impedance (before turn on). Theoretically, the peak voltage is 2 times the applied. The second cause is due to the abrupt reduction of output short circuit current when the TPS20xxC and TPS20xxC-2 turns off and energy stored in the input inductance drives the input voltage high. Input voltage droops may also occur with large load steps and as the TPS20xxC and TPS20xxC-2 output is shorted. Applications with large input inductance (e.g. connecting the evaluation board to the bench power-supply through long cables) may require large input capacitance reduce the voltage overshoot from exceeding the absolute maximum voltage of the device. The fast current-limit speed of the TPS20xxC and TPS20xxC-2 to hard output short circuits isolates the input bus from faults. However, ceramic input capacitance in the range of 1 μF to 22 μF adjacent to the TPS20xxC and TPS20xxC-2 input aids in both speeding the response time and limiting the transient seen on the input power bus. Momentary input transients to 6.5V are permitted.

Output voltage undershoot is caused by the inductance of the output power bus just after a short has occurred and the TPS20xxC and TPS20xxC-2 has abruptly reduced OUT current. Energy stored in the inductance will drive the OUT voltage down and potentially negative as it discharges. Applications with large output inductance (such as from a cable) benefit from use of a high-value output capacitor to control the voltage undershoot. When implementing USB standard applications, a 120 μF minimum output capacitance is required. Typically a 150 μF electrolytic capacitor is used, which is sufficient to control voltage undershoots. However, if the application does not require 120 μF of capacitance, and there is potential to drive the output negative, a minimum of 10 μF ceramic capacitance on the output is recommended. The voltage undershoot should be controlled to less than 1.5 V for 10 μs .

POWER DISSIPATION AND JUNCTION TEMPERATURE

It is good design practice to estimate power dissipation and maximum expected junction temperature of the TPS20xxC and TPS20xxC-2. The system designer can control choices of package, proximity to other power dissipating devices, and printed circuit board (PCB) design based on these calculations. These have a direct influence on maximum junction temperature. Other factors, such as airflow and maximum ambient temperature, are often determined by system considerations. It is important to remember that these calculations do not include the effects of adjacent heat sources, and enhanced or restricted air flow.

Addition of extra PCB copper area around these devices is recommended to reduce the thermal impedance and maintain the junction temperature as low as practical. The lower junction temperatures achieved by soldering the pad improve the efficiency and reliability of both TPS20xxC and TPS20xxC-2 parts and the system. The following examples were used to determine the θ_{JA} Custom thermal impedances noted in the THERMAL INFORMATION table. They were based on use of the JEDEC high-k circuit board construction (2 signal and 2 plane) with 4, 1oz. copper weight, layers.

While it is recommended that the DGN package PAD be soldered to circuit board copper fill and vias for low thermal impedance, there may be cases where this is not desired. For example, use of routing area under the IC. Some devices are available in packages without the Power Pad (DGK) specifically for this purpose. The θ_{JA} for the DGN package with the pad not soldered and no extra copper, is approximately 141°C/W for 0.5 - A and 1- A rated parts, and 139°C/W for the 1.5 - A and 2- A rated parts. The θ_{JA} for the DGK mounted per [Figure 45](#) is 110.3C/W. These values may be used in [Equation 1](#) to determine the maximum junction temperature.

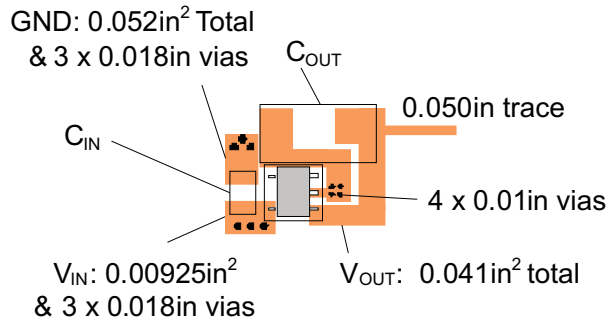

Figure 43. DBV Package PCB Layout Example

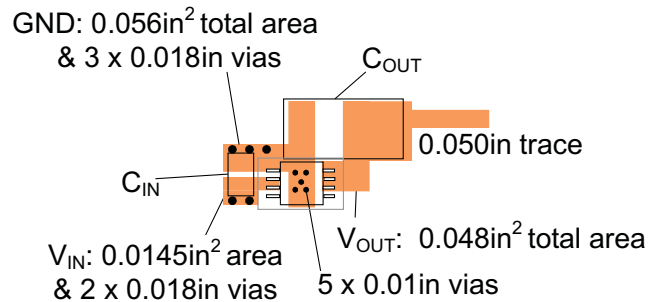

Figure 44. DGN Package PCB Layout Example

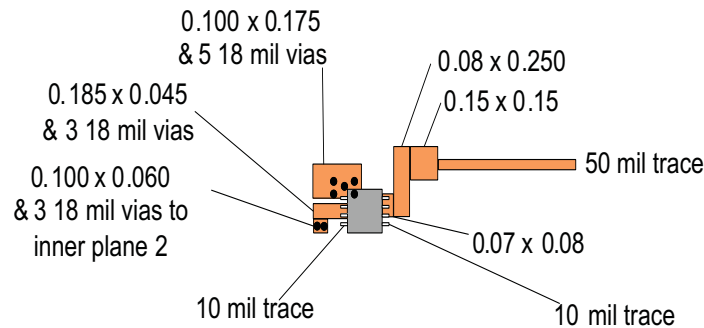

Figure 45. DGK Package PCB Layout Example

The following procedure requires iteration because power loss is due to the internal MOSFET $I^2 \times R_{DS(ON)}$, and $R_{DS(ON)}$ is a function of the junction temperature. As an initial estimate, use the $R_{DS(ON)}$ at 125°C from the TYPICAL CHARACTERISTICS, and the preferred package thermal resistance for the preferred board construction from the THERMAL INFORMATION table.

$$T_J = T_A + ((I_{OUT}^2 \times R_{DS(ON)}) \times \theta_{JA}) \quad (1)$$

Where:

- I_{OUT} = rated OUT pin current (A)
- $R_{DS(ON)}$ = Power switch on-resistance at an assumed T_J (Ω)
- T_A = Maximum ambient temperature ($^{\circ}\text{C}$)
- T_J = Maximum junction temperature ($^{\circ}\text{C}$)
- θ_{JA} = Thermal resistance ($^{\circ}\text{C}/\text{W}$)

If the calculated T_J is substantially different from the original assumption, estimate a new value of $R_{DS(ON)}$ using the typical characteristic plot and recalculate.

If the resulting T_J is not less than 125°C, try a PCB construction and/or package with lower θ_{JA} .

REVISION HISTORY

Changes from Original (June 2011) to Revision A	Page
• 在整个数据表中添加了 DGK 封装信息	1
• 将 TPS2051C、TPS2065C、和 TPS2069C 器件的状态从：预览改为：激活	1
• Corrected pinout numbers for the 5-PIN PACKAGE	7
Changes from Revision A (July 2011) to Revision B	Page
• Changed title of Figure 17 From: NEW FIG To: TPS2065C 50 Ω Short Circuit	9
Changes from Revision B (September 2011) to Revision C	Page
• Changed 在表 1 中，TPS2000C (MSOP-8) 的状态从：预览改为：激活	1
• Changed From: PXF1 To: PXFI and From: PSG1 To: PXGI in the DEVICE INFORMATION table MOSP-8 (DGK) column	2
• Changed the θ_{JA} Custom 2 A Rated DGK value from N/A to 110.3	2
• Added Figure 45 - DGK Package PCB Layout Example	17
Changes from Revision C (October 2011) to Revision D	Page
• 经 UL 检测和认证的添加的特性和和 CB 认证-文件号E169910 (参见 表 1)	1
• 添加了表注释 2，经 UL 检测和认证且 CB 认证完整。	1
• Added V_{IH} and V_{IL} information to the ROC Table	3
Changes from Revision D (February 2012) to Revision E	Page
• Changed the POWER DISSIPATION AND JUNCTION TEMPERATURE section. Replaced paragraph " While it is recommended..."	16

Changes from Revision E (April 2012) to Revision F
Page

• Added 器件 TPS20xxC-2	1
• 将特性从：当 TPS20XXC 被禁用时输出放电改为：已选择具有 (TPS20xxC) 和没有 (TPS20xxC-2) 输出放电的部件	1
• 将 TPS2041C, TPS2061C, TPS2065C-2, TPS2068C 和 TPS2069C-2 添加到表 1 并删除产品预览	1
• 添加了 TPS2069C-2 器件	1
• Added devices TPS2041C, TPS2061C, TPS2065C-2, TPS2068C, and TPS2069C-2 to the Device Information table	2
• Added PTKI in the DEVICE INFORMATION table SOT23-5 (DBV) column (TPS2069C)	2
• Added Note 1 to the RECOMMENDED OPERATING CONDITIONS table	3
• Added TPS2041C, TPS2061C, TPS2068C, TPS2065C-2 and TPS2069C-2 devices to I_{OUT} in the RECOMMENDED OPERATING CONDITIONS table	3
• Added the DBV option to Power Switch $R_{DS(on)}$ 1.5 A rated output, 25°C mΩ	3
• Added the DBV option to Power Switch $R_{DS(on)}$ 1.5 A rated output	3
• Changed I_{SO} Current Limit	3
• Added Leakage Current	3
• Added the DBV option to Power Switch $R_{DS(on)}$ 1.5 A rated output	4
• Changed I_{SO} Current Limit	4
• Added Leakage Current	5
• Changed the second para graph of the ENABLE section	14
• Added sentence to end of paragraph in the OUTPUT DISCHARGE section	15

Changes from Revision F (August 2012) to Revision G
Page

• 从特性中删除：(请见表 1)：经 UL 检测和认证以及 CB 认证-文件号E169910	1
• 从表 1：“经 UL 检测和认证并且 CB 完整”	1
• Changed From: PTKI To: PYKI in the DEVICE INFORMATION table SOT23-5 (DBV) column (TPS2069C)	2

PACKAGING INFORMATION

Orderable Device	Status (1)	Package Type	Package Drawing	Pins	Package Qty	Eco Plan (2)	Lead finish/ Ball material (6)	MSL Peak Temp (3)	Op Temp (°C)	Device Marking (4/5)	Samples
905X0205100	ACTIVE	SOT-23	DBV	5	3000	RoHS & Green	NIPDAU	Level-2-260C-1 YEAR	-40 to 85	VBYQ	Samples
TPS2000CDGK	ACTIVE	VSSOP	DGK	8	80	RoHS & Green	NIPDAUAG SN	Level-2-260C-1 YEAR	-40 to 125	PXFI	Samples
TPS2000CDGKR	ACTIVE	VSSOP	DGK	8	2500	RoHS & Green	NIPDAU SN NIPDAUAG	Level-2-260C-1 YEAR	-40 to 125	PXFI	Samples
TPS2000CDGN	ACTIVE	HVSSOP	DGN	8	80	RoHS & Green	NIPDAU NIPDAUAG	Level-2-260C-1 YEAR	-40 to 125	BCMS	Samples
TPS2000CDGNR	ACTIVE	HVSSOP	DGN	8	2500	RoHS & Green	NIPDAU NIPDAUAG	Level-2-260C-1 YEAR	-40 to 125	BCMS	Samples
TPS2001CDGK	ACTIVE	VSSOP	DGK	8	80	RoHS & Green	NIPDAUAG SN	Level-2-260C-1 YEAR	-40 to 125	PXGI	Samples
TPS2001CDGKR	ACTIVE	VSSOP	DGK	8	2500	RoHS & Green	NIPDAU SN NIPDAUAG	Level-2-260C-1 YEAR	-40 to 125	PXGI	Samples
TPS2001CDGN	ACTIVE	HVSSOP	DGN	8	80	RoHS & Green	NIPDAU NIPDAUAG	Level-2-260C-1 YEAR	-40 to 125	VBWQ	Samples
TPS2001CDGNR	ACTIVE	HVSSOP	DGN	8	2500	RoHS & Green	NIPDAU NIPDAUAG	Level-2-260C-1 YEAR	-40 to 125	VBWQ	Samples
TPS2041CDBVR	ACTIVE	SOT-23	DBV	5	3000	RoHS & Green	NIPDAU SN	Level-2-260C-1 YEAR	-40 to 125	PYJI	Samples
TPS2041CDBVT	ACTIVE	SOT-23	DBV	5	250	RoHS & Green	NIPDAU SN	Level-2-260C-1 YEAR	-40 to 125	PYJI	Samples
TPS2051CDBVR	ACTIVE	SOT-23	DBV	5	3000	RoHS & Green	NIPDAU SN	Level-2-260C-1 YEAR	-40 to 125	VBYQ	Samples
TPS2051CDBVT	ACTIVE	SOT-23	DBV	5	250	RoHS & Green	NIPDAU SN	Level-2-260C-1 YEAR	-40 to 125	VBYQ	Samples
TPS2061CDBVR	ACTIVE	SOT-23	DBV	5	3000	RoHS & Green	NIPDAU	Level-2-260C-1 YEAR	-40 to 125	PXLI	Samples
TPS2061CDBVT	ACTIVE	SOT-23	DBV	5	250	RoHS & Green	NIPDAU SN	Level-2-260C-1 YEAR	-40 to 125	PXLI	Samples
TPS2061CDGN	ACTIVE	HVSSOP	DGN	8	80	RoHS & Green	NIPDAUAG	Level-2-260C-1 YEAR	-40 to 125	PXMI	Samples
TPS2061CDGNR	ACTIVE	HVSSOP	DGN	8	2500	RoHS & Green	NIPDAUAG	Level-2-260C-1 YEAR	-40 to 125	PXMI	Samples
TPS2065CDBVR	ACTIVE	SOT-23	DBV	5	3000	RoHS & Green	NIPDAU	Level-2-260C-1 YEAR	-40 to 125	VCAQ	Samples
TPS2065CDBVR-2	ACTIVE	SOT-23	DBV	5	3000	RoHS & Green	NIPDAU	Level-2-260C-1 YEAR	-40 to 125	PYQI	Samples

Orderable Device	Status (1)	Package Type	Package Drawing	Pins	Package Qty	Eco Plan (2)	Lead finish/ Ball material (6)	MSL Peak Temp (3)	Op Temp (°C)	Device Marking (4/5)	Samples
TPS2065CDBVT	ACTIVE	SOT-23	DBV	5	250	RoHS & Green	NIPDAU	Level-2-260C-1 YEAR	-40 to 125	VCAQ	Samples
TPS2065CDBVT-2	ACTIVE	SOT-23	DBV	5	250	RoHS & Green	NIPDAU SN	Level-2-260C-1 YEAR	-40 to 125	PYQI	Samples
TPS2065CDGN	ACTIVE	HVSSOP	DGN	8	80	RoHS & Green	NIPDAU NIPDAUAG	Level-2-260C-1 YEAR	-40 to 125	VCAQ	Samples
TPS2065CDGN-2	ACTIVE	HVSSOP	DGN	8	80	RoHS & Green	NIPDAUAG	Level-2-260C-1 YEAR	-40 to 125	PYRI	Samples
TPS2065CDGNR	ACTIVE	HVSSOP	DGN	8	2500	RoHS & Green	NIPDAU NIPDAUAG	Level-2-260C-1 YEAR	-40 to 125	VCAQ	Samples
TPS2065CDGNR-2	ACTIVE	HVSSOP	DGN	8	2500	RoHS & Green	NIPDAUAG	Level-2-260C-1 YEAR	-40 to 125	PYRI	Samples
TPS2068CDGN	ACTIVE	HVSSOP	DGN	8	80	RoHS & Green	NIPDAUAG	Level-2-260C-1 YEAR	-40 to 125	PXNI	Samples
TPS2068CDGNR	ACTIVE	HVSSOP	DGN	8	2500	RoHS & Green	NIPDAUAG	Level-2-260C-1 YEAR	-40 to 125	PXNI	Samples
TPS2069CDBVR	ACTIVE	SOT-23	DBV	5	3000	RoHS & Green	NIPDAU SN	Level-2-260C-1 YEAR	-40 to 125	PYKI	Samples
TPS2069CDBVT	ACTIVE	SOT-23	DBV	5	250	RoHS & Green	NIPDAU SN	Level-2-260C-1 YEAR	-40 to 125	PYKI	Samples
TPS2069CDGN	ACTIVE	HVSSOP	DGN	8	80	RoHS & Green	NIPDAU NIPDAUAG	Level-2-260C-1 YEAR	-40 to 125	VBUQ	Samples
TPS2069CDGN-2	ACTIVE	HVSSOP	DGN	8	80	RoHS & Green	NIPDAUAG	Level-2-260C-1 YEAR	-40 to 125	PYSI	Samples
TPS2069CDGNR	ACTIVE	HVSSOP	DGN	8	2500	RoHS & Green	NIPDAU NIPDAUAG	Level-2-260C-1 YEAR	-40 to 125	VBUQ	Samples
TPS2069CDGNR-2	ACTIVE	HVSSOP	DGN	8	2500	RoHS & Green	NIPDAUAG	Level-2-260C-1 YEAR	-40 to 125	PYSI	Samples

(1) The marketing status values are defined as follows:

ACTIVE: Product device recommended for new designs.

LIFEBUY: TI has announced that the device will be discontinued, and a lifetime-buy period is in effect.

NRND: Not recommended for new designs. Device is in production to support existing customers, but TI does not recommend using this part in a new design.

PREVIEW: Device has been announced but is not in production. Samples may or may not be available.

OBSELETE: TI has discontinued the production of the device.

(2) **RoHS:** TI defines "RoHS" to mean semiconductor products that are compliant with the current EU RoHS requirements for all 10 RoHS substances, including the requirement that RoHS substance do not exceed 0.1% by weight in homogeneous materials. Where designed to be soldered at high temperatures, "RoHS" products are suitable for use in specified lead-free processes. TI may reference these types of products as "Pb-Free".

RoHS Exempt: TI defines "RoHS Exempt" to mean products that contain lead but are compliant with EU RoHS pursuant to a specific EU RoHS exemption.

Green: TI defines "Green" to mean the content of Chlorine (Cl) and Bromine (Br) based flame retardants meet JS709B low halogen requirements of <=1000ppm threshold. Antimony trioxide based flame retardants must also meet the <=1000ppm threshold requirement.

- (3) MSL, Peak Temp. - The Moisture Sensitivity Level rating according to the JEDEC industry standard classifications, and peak solder temperature.
- (4) There may be additional marking, which relates to the logo, the lot trace code information, or the environmental category on the device.
- (5) Multiple Device Markings will be inside parentheses. Only one Device Marking contained in parentheses and separated by a "~" will appear on a device. If a line is indented then it is a continuation of the previous line and the two combined represent the entire Device Marking for that device.
- (6) Lead finish/Ball material - Orderable Devices may have multiple material finish options. Finish options are separated by a vertical ruled line. Lead finish/Ball material values may wrap to two lines if the finish value exceeds the maximum column width.

Important Information and Disclaimer:The information provided on this page represents TI's knowledge and belief as of the date that it is provided. TI bases its knowledge and belief on information provided by third parties, and makes no representation or warranty as to the accuracy of such information. Efforts are underway to better integrate information from third parties. TI has taken and continues to take reasonable steps to provide representative and accurate information but may not have conducted destructive testing or chemical analysis on incoming materials and chemicals. TI and TI suppliers consider certain information to be proprietary, and thus CAS numbers and other limited information may not be available for release.

In no event shall TI's liability arising out of such information exceed the total purchase price of the TI part(s) at issue in this document sold by TI to Customer on an annual basis.

TAPE AND REEL INFORMATION



QUADRANT ASSIGNMENTS FOR PIN 1 ORIENTATION IN TAPE



*All dimensions are nominal

Device	Package Type	Package Drawing	Pins	SPQ	Reel Diameter (mm)	Reel Width W1 (mm)	A0 (mm)	B0 (mm)	K0 (mm)	P1 (mm)	W (mm)	Pin1 Quadrant
TPS2000CDGKR	VSSOP	DGK	8	2500	330.0	12.4	5.3	3.4	1.4	8.0	12.0	Q1
TPS2000CDGNR	HVSSOP	DGN	8	2500	330.0	12.4	5.3	3.4	1.4	8.0	12.0	Q1
TPS2001CDGKR	VSSOP	DGK	8	2500	330.0	12.4	5.3	3.4	1.4	8.0	12.0	Q1
TPS2001CDGNR	HVSSOP	DGN	8	2500	330.0	12.4	5.3	3.4	1.4	8.0	12.0	Q1
TPS2001CDGNR	HVSSOP	DGN	8	2500	330.0	12.4	5.3	3.3	1.3	8.0	12.0	Q1
TPS2041CDBVR	SOT-23	DBV	5	3000	180.0	8.4	3.2	3.2	1.4	4.0	8.0	Q3
TPS2041CDBVT	SOT-23	DBV	5	250	180.0	8.4	3.2	3.2	1.4	4.0	8.0	Q3
TPS2051CDBVR	SOT-23	DBV	5	3000	180.0	8.4	3.2	3.2	1.4	4.0	8.0	Q3
TPS2051CDBVR	SOT-23	DBV	5	3000	180.0	8.4	3.2	3.2	1.4	4.0	8.0	Q3
TPS2051CDBVT	SOT-23	DBV	5	250	180.0	8.4	3.2	3.2	1.4	4.0	8.0	Q3
TPS2061CDBVR	SOT-23	DBV	5	3000	180.0	8.4	3.2	3.2	1.4	4.0	8.0	Q3
TPS2061CDBVT	SOT-23	DBV	5	250	178.0	8.4	3.23	3.17	1.37	4.0	8.0	Q3
TPS2061CDBVT	SOT-23	DBV	5	250	180.0	8.4	3.2	3.2	1.4	4.0	8.0	Q3
TPS2061CDGNR	HVSSOP	DGN	8	2500	330.0	12.4	5.3	3.4	1.4	8.0	12.0	Q1
TPS2065CDBVR	SOT-23	DBV	5	3000	178.0	9.0	3.23	3.17	1.37	4.0	8.0	Q3
TPS2065CDBVR-2	SOT-23	DBV	5	3000	180.0	8.4	3.2	3.2	1.4	4.0	8.0	Q3

Device	Package Type	Package Drawing	Pins	SPQ	Reel Diameter (mm)	Reel Width W1 (mm)	A0 (mm)	B0 (mm)	K0 (mm)	P1 (mm)	W (mm)	Pin1 Quadrant
TPS2065CDBVT	SOT-23	DBV	5	250	178.0	8.4	3.23	3.17	1.37	4.0	8.0	Q3
TPS2065CDBVT-2	SOT-23	DBV	5	250	180.0	8.4	3.2	3.2	1.4	4.0	8.0	Q3
TPS2065CDBVT-2	SOT-23	DBV	5	250	178.0	8.4	3.23	3.17	1.37	4.0	8.0	Q3
TPS2065CDGNR	HVSSOP	DGN	8	2500	330.0	12.4	5.3	3.4	1.4	8.0	12.0	Q1
TPS2065CDGNR-2	HVSSOP	DGN	8	2500	330.0	12.4	5.3	3.4	1.4	8.0	12.0	Q1
TPS2068CDGNR	HVSSOP	DGN	8	2500	330.0	12.4	5.3	3.4	1.4	8.0	12.0	Q1
TPS2069CDBVR	SOT-23	DBV	5	3000	180.0	8.4	3.2	3.2	1.4	4.0	8.0	Q3
TPS2069CDBVT	SOT-23	DBV	5	250	180.0	8.4	3.2	3.2	1.4	4.0	8.0	Q3
TPS2069CDGNR	HVSSOP	DGN	8	2500	330.0	12.4	5.3	3.3	1.3	8.0	12.0	Q1
TPS2069CDGNR	HVSSOP	DGN	8	2500	330.0	12.4	5.3	3.4	1.4	8.0	12.0	Q1
TPS2069CDGNR-2	HVSSOP	DGN	8	2500	330.0	12.4	5.3	3.4	1.4	8.0	12.0	Q1

TAPE AND REEL BOX DIMENSIONS



*All dimensions are nominal

Device	Package Type	Package Drawing	Pins	SPQ	Length (mm)	Width (mm)	Height (mm)
TPS2000CDGKR	VSSOP	DGK	8	2500	353.0	353.0	32.0
TPS2000CDGNR	HVSSOP	DGN	8	2500	360.0	162.0	98.0
TPS2001CDGKR	VSSOP	DGK	8	2500	366.0	364.0	50.0
TPS2001CDGNR	HVSSOP	DGN	8	2500	360.0	162.0	98.0
TPS2001CDGNR	HVSSOP	DGN	8	2500	370.0	355.0	55.0
TPS2041CDBVR	SOT-23	DBV	5	3000	210.0	185.0	35.0
TPS2041CDBVT	SOT-23	DBV	5	250	210.0	185.0	35.0
TPS2051CDBVR	SOT-23	DBV	5	3000	210.0	185.0	35.0
TPS2051CDBVR	SOT-23	DBV	5	3000	210.0	185.0	35.0
TPS2051CDBVT	SOT-23	DBV	5	250	210.0	185.0	35.0
TPS2061CDBVR	SOT-23	DBV	5	3000	210.0	185.0	35.0
TPS2061CDBVT	SOT-23	DBV	5	250	180.0	180.0	18.0
TPS2061CDBVT	SOT-23	DBV	5	250	210.0	185.0	35.0
TPS2061CDGNR	HVSSOP	DGN	8	2500	366.0	364.0	50.0
TPS2065CDBVR	SOT-23	DBV	5	3000	180.0	180.0	18.0
TPS2065CDBVR-2	SOT-23	DBV	5	3000	210.0	185.0	35.0
TPS2065CDBVT	SOT-23	DBV	5	250	180.0	180.0	18.0
TPS2065CDBVT-2	SOT-23	DBV	5	250	210.0	185.0	35.0

Device	Package Type	Package Drawing	Pins	SPQ	Length (mm)	Width (mm)	Height (mm)
TPS2065CDBVT-2	SOT-23	DBV	5	250	180.0	180.0	18.0
TPS2065CDGNR	HVSSOP	DGN	8	2500	360.0	162.0	98.0
TPS2065CDGNR-2	HVSSOP	DGN	8	2500	366.0	364.0	50.0
TPS2068CDGNR	HVSSOP	DGN	8	2500	366.0	364.0	50.0
TPS2069CDBVR	SOT-23	DBV	5	3000	210.0	185.0	35.0
TPS2069CDBVT	SOT-23	DBV	5	250	210.0	185.0	35.0
TPS2069CDGNR	HVSSOP	DGN	8	2500	370.0	355.0	55.0
TPS2069CDGNR	HVSSOP	DGN	8	2500	366.0	364.0	50.0
TPS2069CDGNR-2	HVSSOP	DGN	8	2500	366.0	364.0	50.0

TUBE

*All dimensions are nominal

Device	Package Name	Package Type	Pins	SPQ	L (mm)	W (mm)	T (µm)	B (mm)
TPS2000CDGK	DGK	VSSOP	8	80	330	6.55	500	2.88
TPS2000CDGN	DGN	HVSSOP	8	80	322	6.55	1000	3.01
TPS2000CDGN	DGN	HVSSOP	8	80	330	6.55	500	2.88
TPS2001CDGK	DGK	VSSOP	8	80	330	6.55	500	2.88
TPS2001CDGN	DGN	HVSSOP	8	80	322	6.55	1000	3.01
TPS2001CDGN	DGN	HVSSOP	8	80	330	6.55	500	2.88
TPS2061CDGN	DGN	HVSSOP	8	80	330	6.55	500	2.88
TPS2065CDGN	DGN	HVSSOP	8	80	330	6.55	500	2.88
TPS2065CDGN	DGN	HVSSOP	8	80	322	6.55	1000	3.01
TPS2065CDGN-2	DGN	HVSSOP	8	80	330	6.55	500	2.88
TPS2068CDGN	DGN	HVSSOP	8	80	330	6.55	500	2.88
TPS2069CDGN	DGN	HVSSOP	8	80	322	6.55	1000	3.01
TPS2069CDGN	DGN	HVSSOP	8	80	330	6.55	500	2.88
TPS2069CDGN-2	DGN	HVSSOP	8	80	330	6.55	500	2.88

GENERIC PACKAGE VIEW

DGN 8

PowerPAD™ HVSSOP - 1.1 mm max height

3 x 3, 0.65 mm pitch

SMALL OUTLINE PACKAGE

This image is a representation of the package family, actual package may vary.
Refer to the product data sheet for package details.

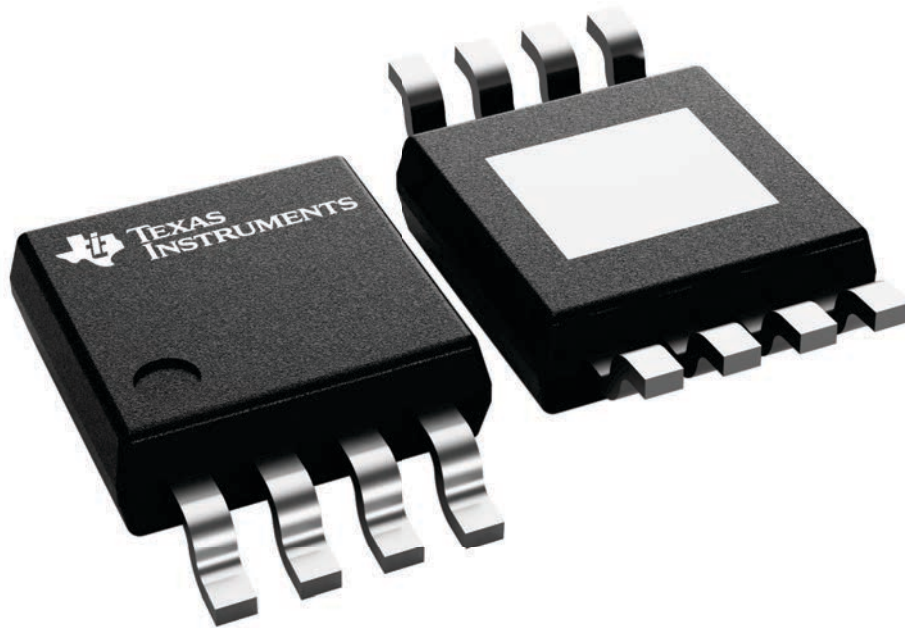

4225482/B

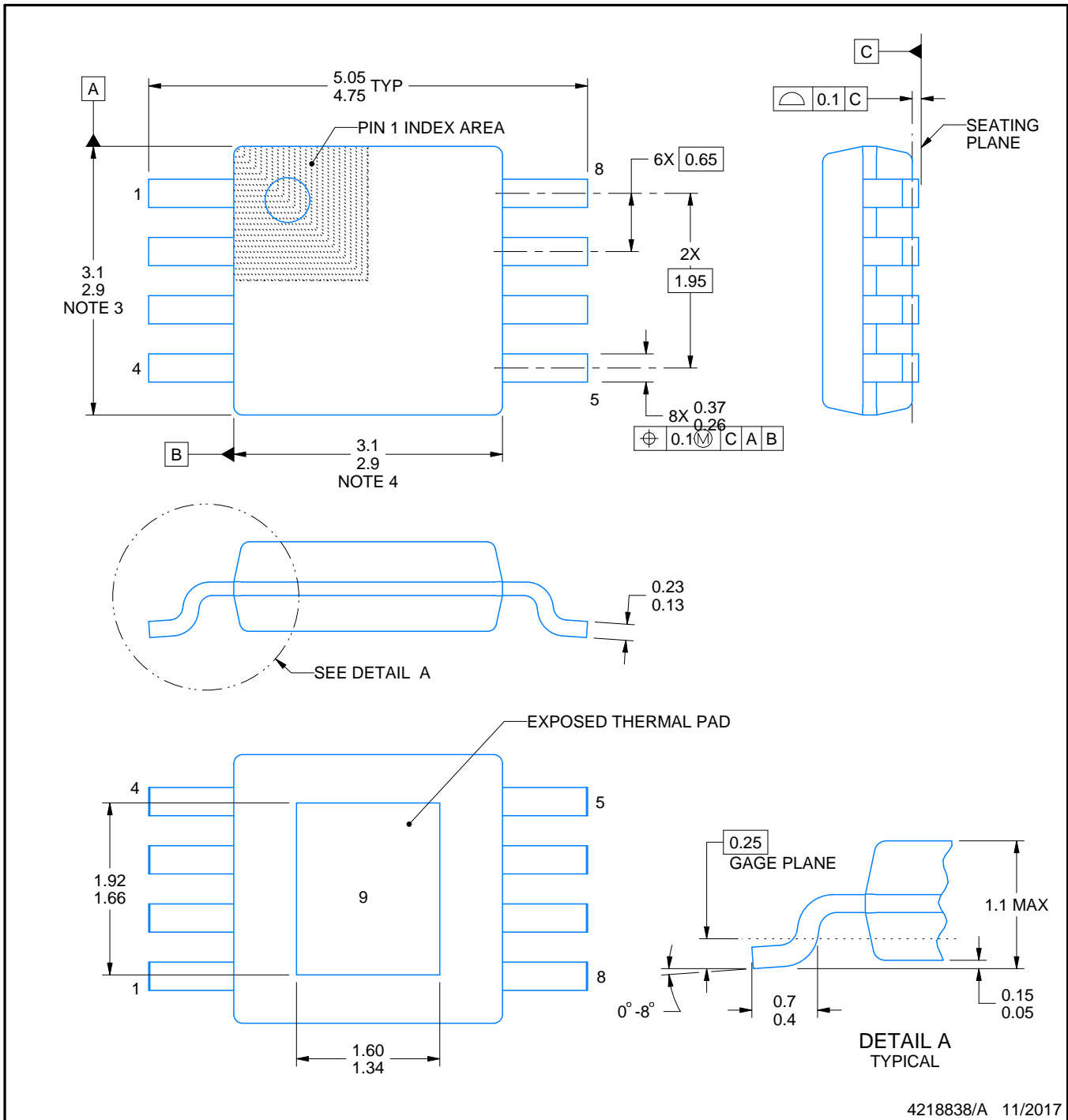
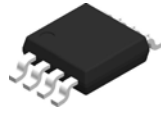

4218838/A 11/2017

NOTES:

1. All linear dimensions are in millimeters. Any dimensions in parenthesis are for reference only. Dimensioning and tolerancing per ASME Y14.5M.
2. This drawing is subject to change without notice.
3. This dimension does not include mold flash, protrusions, or gate burrs. Mold flash, protrusions, or gate burrs shall not exceed 0.15 mm per side.
4. This dimension does not include interlead flash. Interlead flash shall not exceed 0.25 mm per side.
5. Reference JEDEC registration MO-187.

EXAMPLE BOARD LAYOUT

DGN0008C

HVSSOP - 1.1 mm max height

SMALL OUTLINE PACKAGE

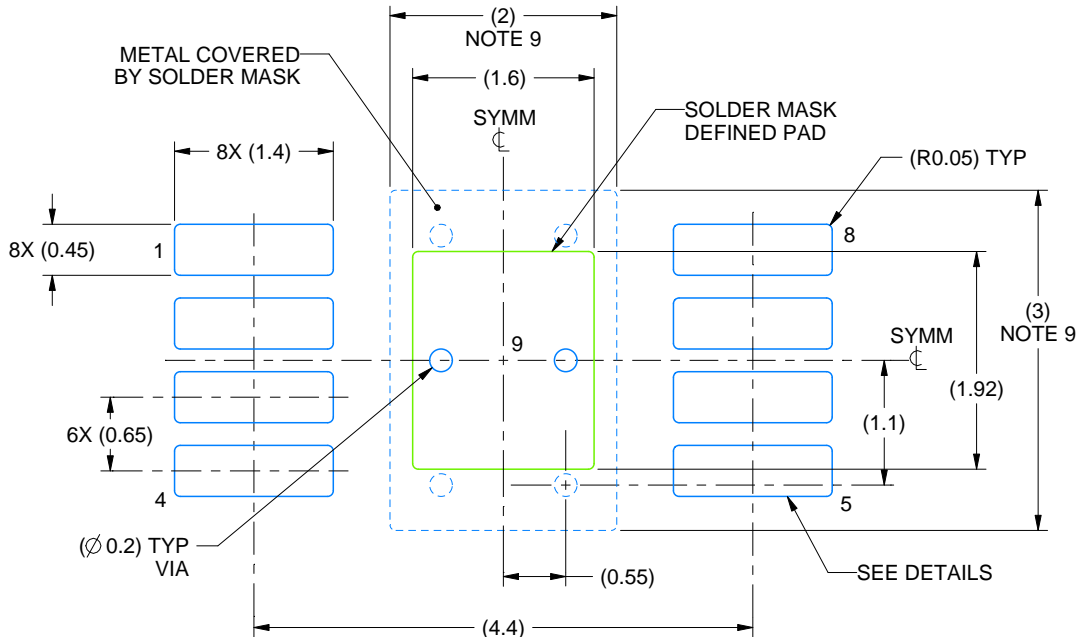

LAND PATTERN EXAMPLE
EXPOSED METAL SHOWN
SCALE: 15X

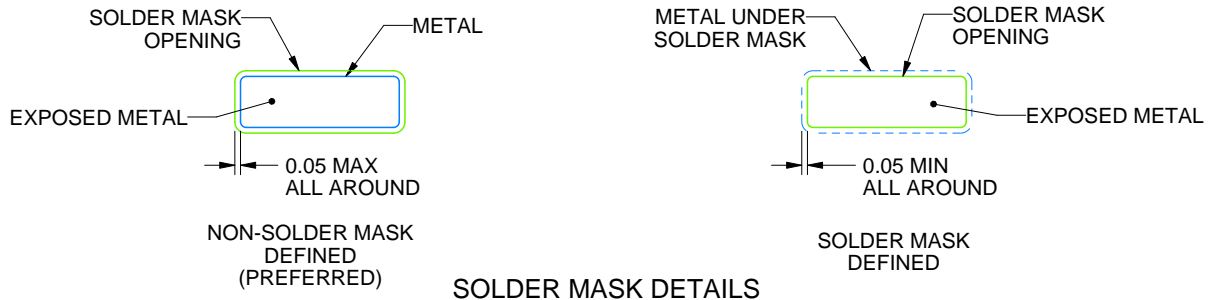

SOLDER MASK DETAILS

4218838/A 11/2017

NOTES: (continued)

6. Publication IPC-7351 may have alternate designs.
7. Solder mask tolerances between and around signal pads can vary based on board fabrication site.
8. Vias are optional depending on application, refer to device data sheet. If any vias are implemented, refer to their locations shown on this view. It is recommended that vias under paste be filled, plugged or tented.
9. Size of metal pad may vary due to creepage requirement.

EXAMPLE STENCIL DESIGN

DGN0008C

HVSSOP - 1.1 mm max height

SMALL OUTLINE PACKAGE

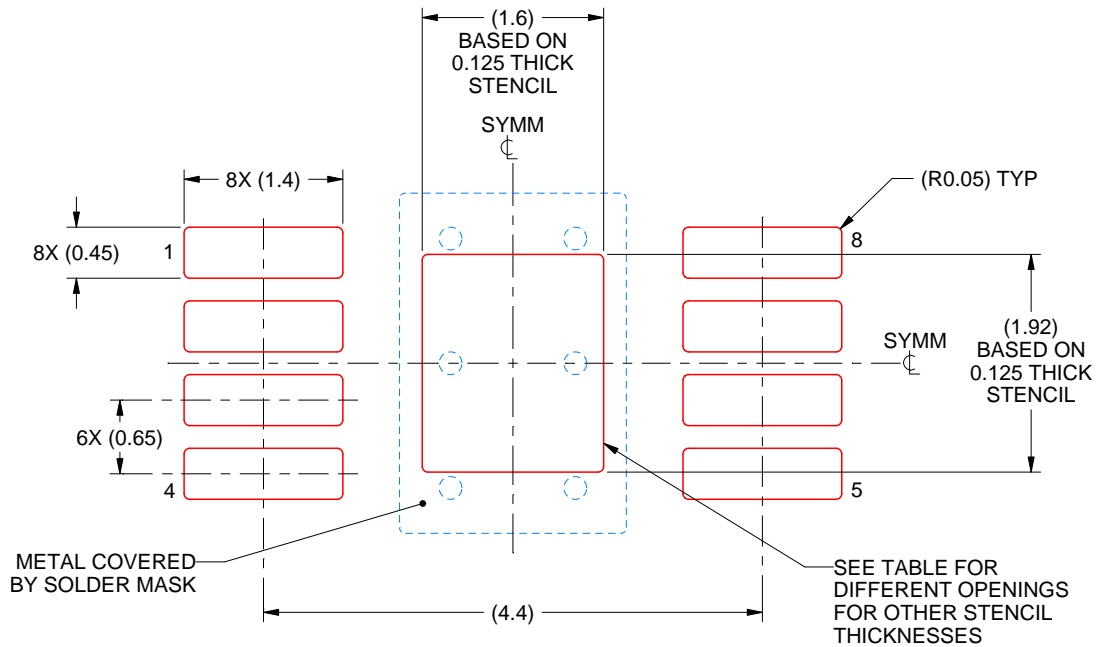

SOLDER PASTE EXAMPLE
EXPOSED PAD 9:
100% PRINTED SOLDER COVERAGE BY AREA
SCALE: 15X

STENCIL THICKNESS	SOLDER STENCIL OPENING
0.1	1.79 X 2.15
0.125	1.60 X 1.92 (SHOWN)
0.15	1.46 X 1.75
0.175	1.35 X 1.62

4218838/A 11/2017

NOTES: (continued)

10. Laser cutting apertures with trapezoidal walls and rounded corners may offer better paste release. IPC-7525 may have alternate design recommendations.
11. Board assembly site may have different recommendations for stencil design.

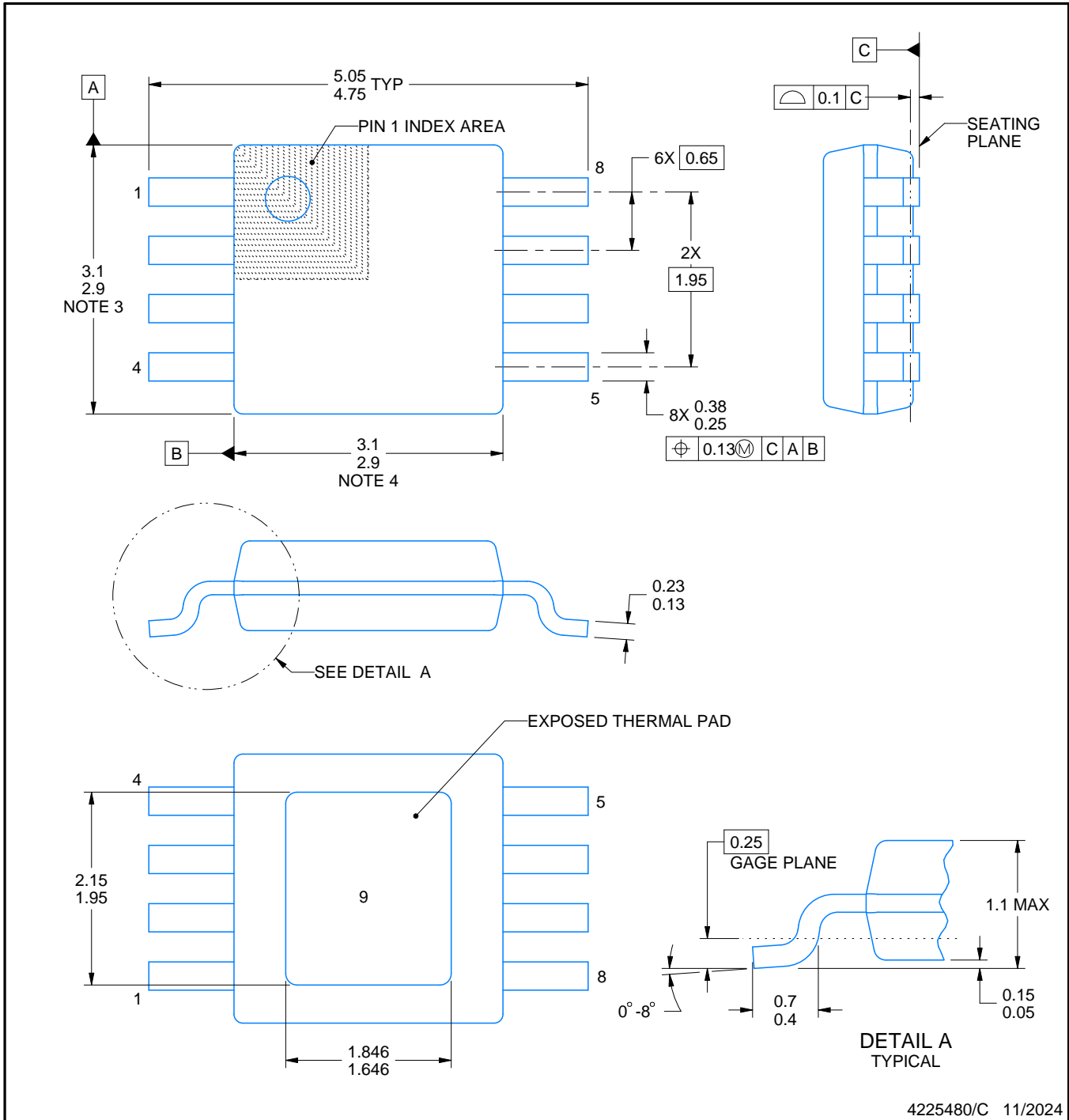
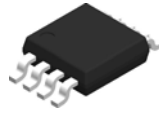

4225480/C 11/2024

NOTES:

PowerPAD is a trademark of Texas Instruments.

1. All linear dimensions are in millimeters. Any dimensions in parenthesis are for reference only. Dimensioning and tolerancing per ASME Y14.5M.
2. This drawing is subject to change without notice.
3. This dimension does not include mold flash, protrusions, or gate burrs. Mold flash, protrusions, or gate burrs shall not exceed 0.15 mm per side.
4. This dimension does not include interlead flash. Interlead flash shall not exceed 0.25 mm per side.
5. Reference JEDEC registration MO-187.

EXAMPLE BOARD LAYOUT

DGN0008G

PowerPAD™ HVSSOP - 1.1 mm max height

SMALL OUTLINE PACKAGE

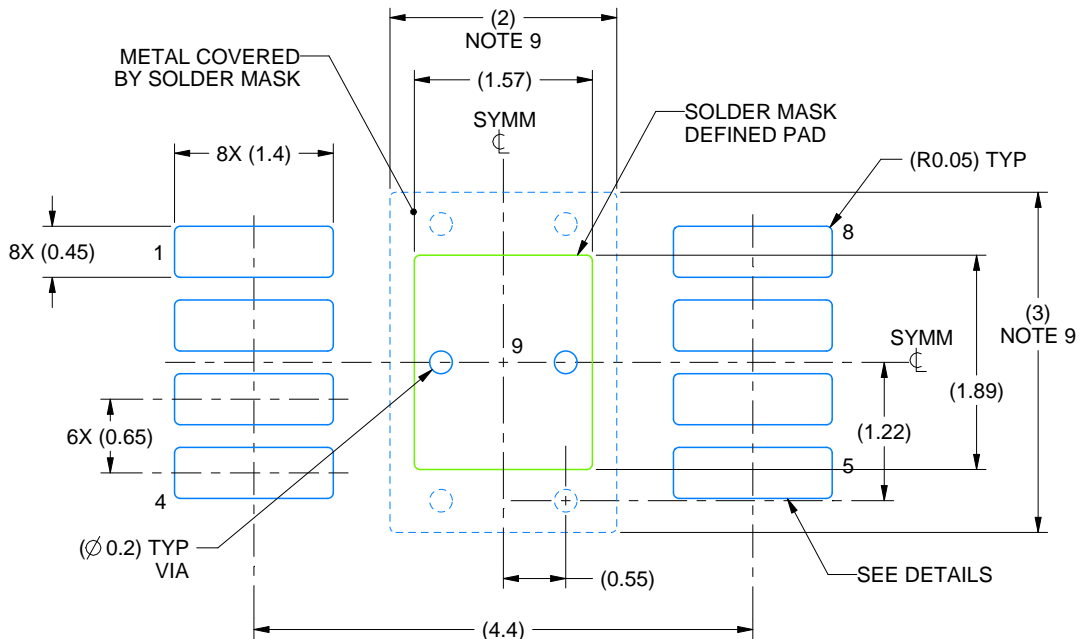

LAND PATTERN EXAMPLE
EXPOSED METAL SHOWN
SCALE: 15X

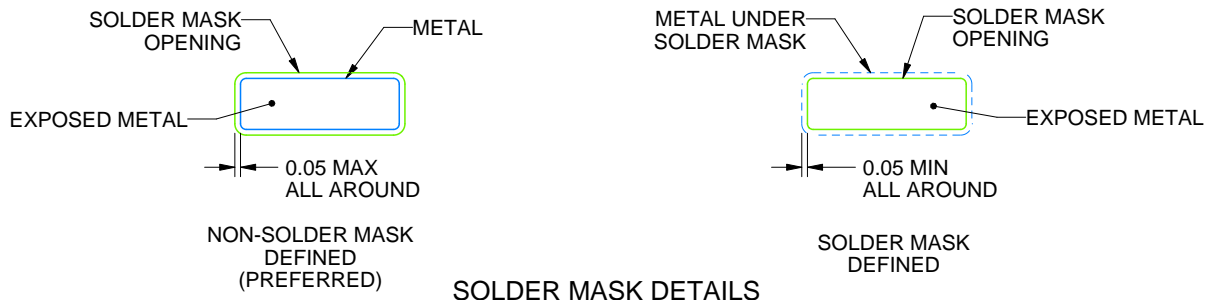

SOLDER MASK DETAILS

4225480/C 11/2024

NOTES: (continued)

- 6. Publication IPC-7351 may have alternate designs.
- 7. Solder mask tolerances between and around signal pads can vary based on board fabrication site.
- 8. Vias are optional depending on application, refer to device data sheet. If any vias are implemented, refer to their locations shown on this view. It is recommended that vias under paste be filled, plugged or tented.
- 9. Size of metal pad may vary due to creepage requirement.

EXAMPLE STENCIL DESIGN

DGN0008G

PowerPAD™ HVSSOP - 1.1 mm max height

SMALL OUTLINE PACKAGE

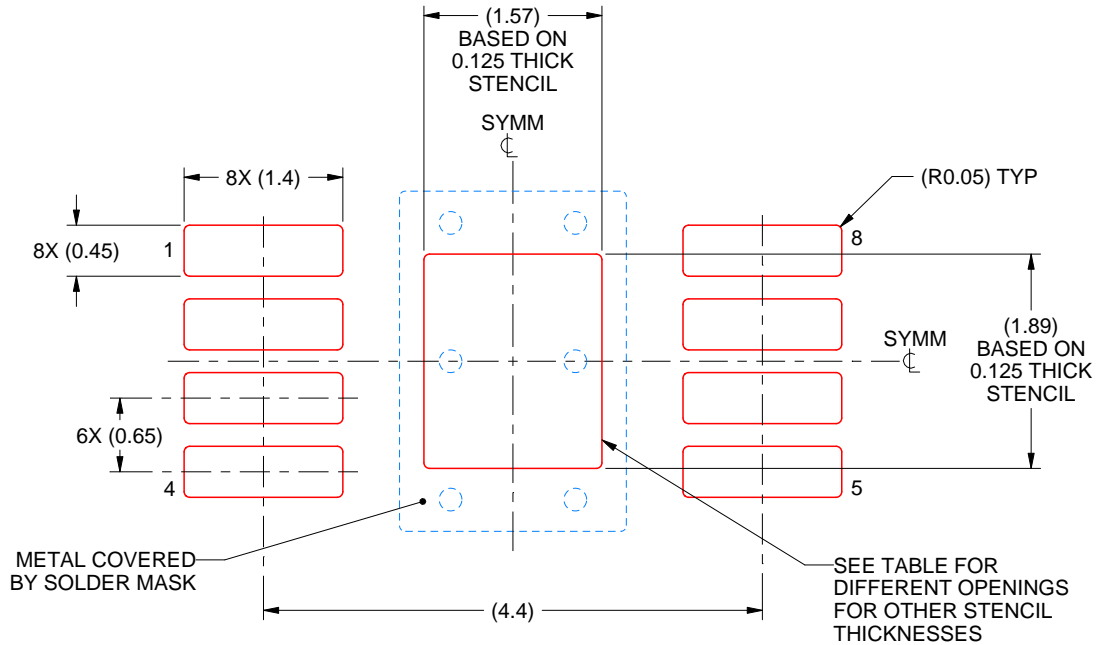

SOLDER PASTE EXAMPLE
EXPOSED PAD 9:
100% PRINTED SOLDER COVERAGE BY AREA
SCALE: 15X

STENCIL THICKNESS	SOLDER STENCIL OPENING
0.1	1.76 X 2.11
0.125	1.57 X 1.89 (SHOWN)
0.15	1.43 X 1.73
0.175	1.33 X 1.60

4225480/C 11/2024

NOTES: (continued)

10. Laser cutting apertures with trapezoidal walls and rounded corners may offer better paste release. IPC-7525 may have alternate design recommendations.
11. Board assembly site may have different recommendations for stencil design.

DBV0005A



PACKAGE OUTLINE

SOT-23 - 1.45 mm max height

SMALL OUTLINE TRANSISTOR

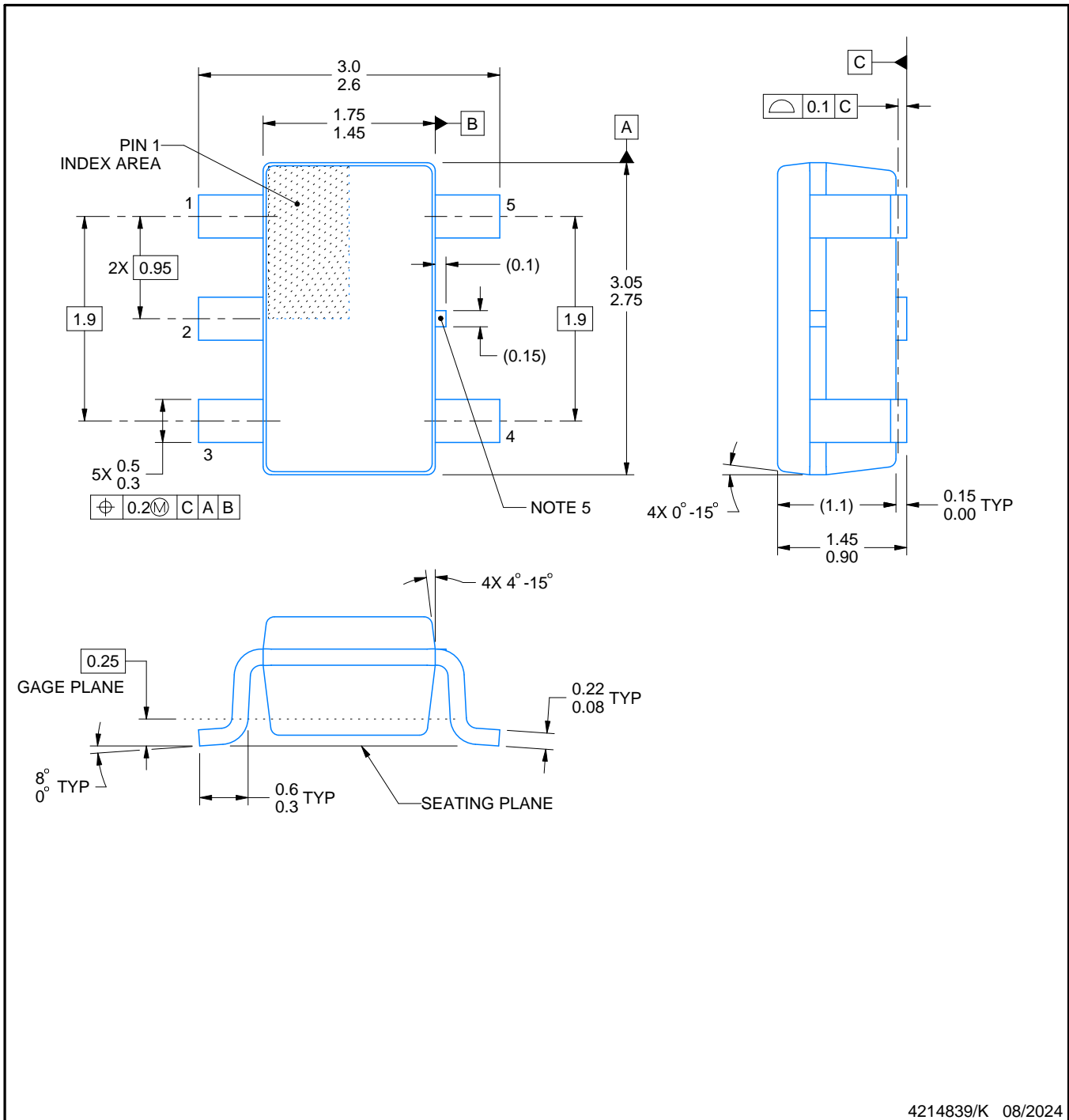

4214839/K 08/2024

NOTES:

1. All linear dimensions are in millimeters. Any dimensions in parenthesis are for reference only. Dimensioning and tolerancing per ASME Y14.5M.
2. This drawing is subject to change without notice.
3. Reference JEDEC MO-178.
4. Body dimensions do not include mold flash, protrusions, or gate burrs. Mold flash, protrusions, or gate burrs shall not exceed 0.25 mm per side.
5. Support pin may differ or may not be present.

EXAMPLE BOARD LAYOUT

DBV0005A

SOT-23 - 1.45 mm max height

SMALL OUTLINE TRANSISTOR



LAND PATTERN EXAMPLE
EXPOSED METAL SHOWN
SCALE:15X

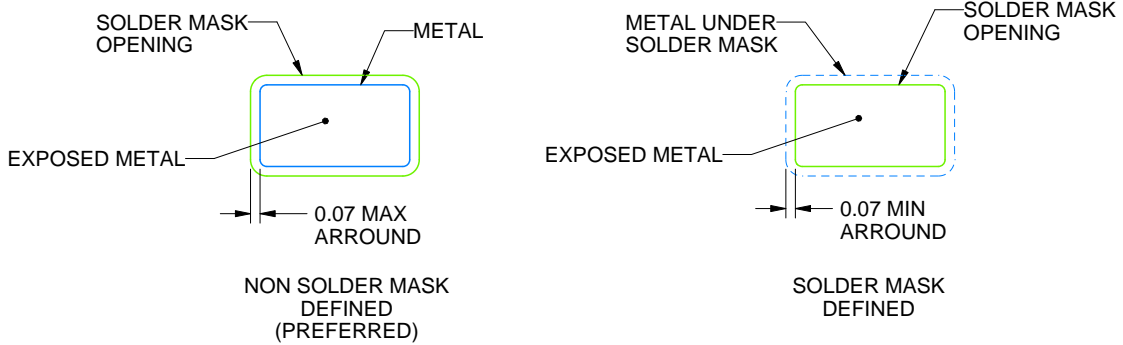

SOLDER MASK DETAILS

4214839/K 08/2024

NOTES: (continued)

- 6. Publication IPC-7351 may have alternate designs.
- 7. Solder mask tolerances between and around signal pads can vary based on board fabrication site.

EXAMPLE STENCIL DESIGN

DBV0005A

SOT-23 - 1.45 mm max height

SMALL OUTLINE TRANSISTOR



SOLDER PASTE EXAMPLE
BASED ON 0.125 mm THICK STENCIL
SCALE:15X

4214839/K 08/2024

NOTES: (continued)

8. Laser cutting apertures with trapezoidal walls and rounded corners may offer better paste release. IPC-7525 may have alternate design recommendations.
9. Board assembly site may have different recommendations for stencil design.

DGK0008A



PACKAGE OUTLINE

VSSOP - 1.1 mm max height

SMALL OUTLINE PACKAGE



4214862/A 04/2023

NOTES:

PowerPAD is a trademark of Texas Instruments.

1. All linear dimensions are in millimeters. Any dimensions in parenthesis are for reference only. Dimensioning and tolerancing per ASME Y14.5M.
2. This drawing is subject to change without notice.
3. This dimension does not include mold flash, protrusions, or gate burrs. Mold flash, protrusions, or gate burrs shall not exceed 0.15 mm per side.
4. This dimension does not include interlead flash. Interlead flash shall not exceed 0.25 mm per side.
5. Reference JEDEC registration MO-187.

EXAMPLE BOARD LAYOUT

DGK0008A

™ VSSOP - 1.1 mm max height

SMALL OUTLINE PACKAGE



LAND PATTERN EXAMPLE
EXPOSED METAL SHOWN
SCALE: 15X



SOLDER MASK DETAILS

4214862/A 04/2023

NOTES: (continued)

6. Publication IPC-7351 may have alternate designs.
7. Solder mask tolerances between and around signal pads can vary based on board fabrication site.
8. Vias are optional depending on application, refer to device data sheet. If any vias are implemented, refer to their locations shown on this view. It is recommended that vias under paste be filled, plugged or tented.
9. Size of metal pad may vary due to creepage requirement.

EXAMPLE STENCIL DESIGN

DGK0008A

TM VSSOP - 1.1 mm max height

SMALL OUTLINE PACKAGE



SOLDER PASTE EXAMPLE
SCALE: 15X

4214862/A 04/2023

NOTES: (continued)

11. Laser cutting apertures with trapezoidal walls and rounded corners may offer better paste release. IPC-7525 may have alternate design recommendations.
12. Board assembly site may have different recommendations for stencil design.

重要通知和免责声明

TI“按原样”提供技术和可靠性数据（包括数据表）、设计资源（包括参考设计）、应用或其他设计建议、网络工具、安全信息和其他资源，不保证没有瑕疵且不做任何明示或暗示的担保，包括但不限于对适销性、某特定用途方面的适用性或不侵犯任何第三方知识产权的暗示担保。

这些资源可供使用 TI 产品进行设计的熟练开发人员使用。您将自行承担以下全部责任：(1) 针对您的应用选择合适的 TI 产品，(2) 设计、验证并测试您的应用，(3) 确保您的应用满足相应标准以及任何其他功能安全、信息安全、监管或其他要求。

这些资源如有变更，恕不另行通知。TI 授权您仅可将这些资源用于研发本资源所述的 TI 产品的相关应用。严禁以其他方式对这些资源进行复制或展示。您无权使用任何其他 TI 知识产权或任何第三方知识产权。您应全额赔偿因在这些资源的使用中对 TI 及其代表造成的任何索赔、损害、成本、损失和债务，TI 对此概不负责。

TI 提供的产品受 [TI 的销售条款](#) 或 [ti.com](#) 上其他适用条款/TI 产品随附的其他适用条款的约束。TI 提供这些资源并不会扩展或以其他方式更改 TI 针对 TI 产品发布的适用的担保或担保免责声明。

TI 反对并拒绝您可能提出的任何其他或不同的条款。

邮寄地址：Texas Instruments, Post Office Box 655303, Dallas, Texas 75265
版权所有 © 2025，德州仪器 (TI) 公司