

限流配电开关

 查询样品: [TPS2062-Q1](#), [TPS2065-Q1](#)

特性

- 符合汽车应用要求
- 70mΩ** 高侧金属氧化物半导体场效应晶体管 (MOSFET)
- 1A** 持续电流
- 散热和短路保护
- 精确电流限制
(最小值 **1.1A**, 最大值**1.9**)
- 工作电压范围: **2.7V** 至 **5.5V**
- 上升时间典型值 **0.6ms**
- 欠压闭锁
- 毛刺脉冲消除故障报告 (\overline{OC})
- 加电期间无 \overline{OC} 毛刺脉冲
- 最大待机电源电流 **1μA**

- 双向开关
- 环境温度范围: **-40°C** 至 **125°C**
- 内置软启动
- UL** 列表-文件号 **E169910**

应用范围

- 大电容负载
- 短路保护

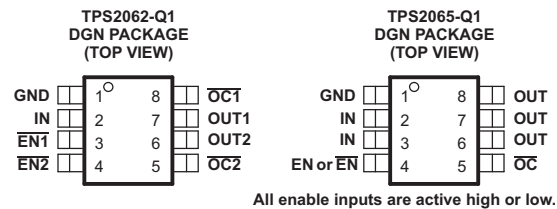

说明

TPS2062/5-Q1 配电开关主要用于很可能出现大电容负载和短路情况的应用。这个器件组装有一个用于配电系统的 70mΩ N-通道 MOSFET 电源开关。此类系统要求在单一封装内具有多个电源开关。每个开关由一个逻辑使能输入控制。栅极驱动由一个内部电荷泵提供, 此电荷泵设计用于控制电源开关上升时间和下降时间以大大减少切换期间的电流涌入。电荷泵无需外部组件并可在低至 2.7V 的电源电压下工作。

当输出负载超过限流阈值或者短路出现时, 此器件通过切换至恒定电流模式, 并通过将过流 (\overline{OCx}) 下拉至逻辑输出低电平来将输出电流限制在安全水平上。当持续重过载和短路增加了开关内的功率耗散时, 将引起结温上升, 这时一个过热保护电路将关闭此开关以避免器件损坏。一旦器件充分冷却, 此器件将自动从热关断中恢复。内部电路确保此开关在有效输入电压出现前保持关闭状态。这个配电开关设计用于将电流限值的典型值设定在 1.5A 上。

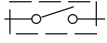
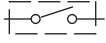
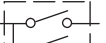
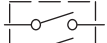
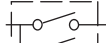
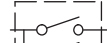
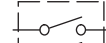
GENERAL SWITCH CATALOG						
33 mΩ, Single  TPS201xA 0.2 A to 2 A TPS202x 0.2 A to 2 A TPS203x 0.2 A to 2 A	80 mΩ, Single  TPS2014 600 mA TPS2015 1 A TPS2041B 500 mA TPS2051B 500 mA TPS2045A 250 mA TPS2049 100 mA TPS2055A 250 mA TPS2061 1 A TPS2065 1 A TPS2068 1.5 A TPS2069 1.5 A	80 mΩ, Dual  TPS2042B 500 mA TPS2052B 500 mA TPS2046B 250 mA TPS2056 250 mA TPS2062 1 A TPS2066 1 A TPS2060 1.5 A TPS2064 1.5 A	80 mΩ, Dual  TPS2080 500 mA TPS2081 500 mA TPS2082 500 mA TPS2090 250 mA TPS2091 250 mA TPS2092 250 mA	80 mΩ, Triple  TPS2043B 500 mA TPS2053B 500 mA TPS2047B 250 mA TPS2057A 250 mA TPS2063 1 A TPS2067 1 A	80 mΩ, Quad  TPS2044B 500 mA TPS2054B 500 mA TPS2048A 250 mA TPS2058 250 mA	80 mΩ, Quad  TPS2085 500 mA TPS2086 500 mA TPS2087 500 mA TPS2095 250 mA TPS2096 250 mA TPS2097 250 mA



Please be aware that an important notice concerning availability, standard warranty, and use in critical applications of Texas Instruments semiconductor products and disclaimers thereto appears at the end of this data sheet.

PowerPAD is a trademark of Texas Instruments.

PRODUCTION DATA information is current as of publication date. Products conform to specifications per the terms of the Texas Instruments standard warranty. Production processing does not necessarily include testing of all parameters.

Copyright © 2011–2012, Texas Instruments Incorporated
English Data Sheet: [SLVSA01](#)



These devices have limited built-in ESD protection. The leads should be shorted together or the device placed in conductive foam during storage or handling to prevent electrostatic damage to the MOS gates.

ORDERING INFORMATION⁽¹⁾

T _A	PACKAGE ⁽²⁾		ORDERABLE PART NUMBER	TOP-SIDE MARKING
-40°C to 125°C	MSOP – DGN	Reel of 2500	TPS2062QDGNRQ1	PSOQ
	VSSOP - DGN	Reel of 2500	TPS2065QDGNRQ1	PTLQ

- (1) For the most current package and ordering information, see the Package Option Addendum at the end of this document, or see the TI web site at www.ti.com.
- (2) Package drawings, thermal data, and symbolization are available at www.ti.com/packaging.

ABSOLUTE MAXIMUM RATINGS

over operating free-air temperature range unless otherwise noted⁽¹⁾

Input voltage range, V _{I(IN)} ⁽²⁾	-0.3 V to 6 V	
Output voltage range ⁽²⁾ , V _{O(OUTX)}	-0.3 V to 6 V	
Input voltage range, V _{I(ENx)}	-0.3 V to 6 V	
Voltage range, V _{I(OCCx)}	-0.3 V to 6 V	
Continuous output current, I _{O(OUTX)}	Internally limited	
Continuous total power dissipation	See Dissipation Rating Table	
Operating virtual junction temperature range, T _J	-40°C to 150°C	
Storage temperature range, T _{stg}	-65°C to 150°C	
Electrostatic discharge (ESD) protection	Human body model (HBM)	2 kV
	Charge device model (CDM)	1000 V
	Machine model (MM)	100 V

- (1) Stresses beyond those listed under *absolute maximum ratings* may cause permanent damage to the device. These are stress ratings only, and functional operation of the device at these or any other conditions beyond those indicated under *recommended operating conditions* is not implied. Exposure to absolute-maximum-rated conditions for extended periods may affect device reliability.
- (2) All voltages are with respect to GND.

DISSIPATING RATING TABLE

PACKAGE	T _A ≤ 25°C POWER RATING	DERATING FACTOR ABOVE T _A = 25°C	T _A = 125°C POWER RATING
DGN-8	2.14 W	17.123 mW/°C	428 mW

RECOMMENDED OPERATING CONDITIONS

	MIN	MAX	UNIT
Input voltage, V _{I(IN)}	2.7	5.5	V
Input voltage, V _{I(ENx)}	0	5.5	V
Continuous output current, I _{O(OUTX)}	0	1	A
Ambient temperature, T _A	-40	125	°C
Operating virtual junction temperature, T _J	-40	150	°C

ELECTRICAL CHARACTERISTICS

 over recommended operating junction temperature range, $V_{I(IN)} = 5.5\text{ V}$, $I_O = 1\text{ A}$, $V_{I(\overline{ENx})} = 0\text{ V}$ (unless otherwise noted)

PARAMETER		TEST CONDITIONS ⁽¹⁾		MIN	TYP	MAX	UNIT
POWER SWITCH							
$r_{DS(on)}$	Static drain-source on-state resistance, 5-V operation and 3.3-V operation	$V_{I(IN)} = 5\text{ V}$ or 3.3 V , $I_O = 1\text{ A}$, $-40^\circ\text{C} \leq T_A \leq 125^\circ\text{C}$			70	135	m Ω
	Static drain-source on-state resistance, 2.7-V operation ⁽²⁾	$V_{I(IN)} = 2.7\text{ V}$, $I_O = 1\text{ A}$, $-40^\circ\text{C} \leq T_A \leq 125^\circ\text{C}$			75	150	m Ω
t_r	Rise time, output	$V_{I(IN)} = 5.5\text{ V}$	$C_L = 1\text{ }\mu\text{F}$, $R_L = 5\text{ }\Omega$, $T_A = 25^\circ\text{C}$		0.6	1.5	ms
		$V_{I(IN)} = 2.7\text{ V}$			0.4	1	
t_f	Fall time, output	$V_{I(IN)} = 5.5\text{ V}$	$C_L = 1\text{ }\mu\text{F}$, $R_L = 5\text{ }\Omega$, $T_A = 25^\circ\text{C}$		0.05	0.5	ms
		$V_{I(IN)} = 2.7\text{ V}$			0.05	0.5	
ENABLE INPUT \overline{EN} OR EN							
V_{IH}	High-level input voltage	$2.7\text{ V} \leq V_{I(IN)} \leq 5.5\text{ V}$		2			V
V_{IL}	Low-level input voltage	$2.7\text{ V} \leq V_{I(IN)} \leq 5.5\text{ V}$				0.8	
I_I	Input current	$V_{I(\overline{ENx})} = 0\text{ V}$ or 5.5 V		-1		1	μA
t_{on}	Turnon time	$C_L = 100\text{ }\mu\text{F}$, $R_L = 5\text{ }\Omega$				3	ms
t_{off}	Turnoff time	$C_L = 100\text{ }\mu\text{F}$, $R_L = 5\text{ }\Omega$				10	
CURRENT LIMIT							
I_{OS}	Short-circuit output current ⁽¹⁾	$V_{I(IN)} = 5\text{ V}$, OUT connected to GND, Device enabled into short-circuit	$T_A = 25^\circ\text{C}$	1.1	1.5	1.9	A
			$-40^\circ\text{C} \leq T_A \leq 125^\circ\text{C}$	1.1	1.5	2.1	
I_{OC_TRIP}	Overcurrent trip threshold	$V_{I(IN)} = 5\text{ V}$, current ramp ($\leq 100\text{ A/s}$) on OUT		1.6	2.3	2.9	A
SUPPLY CURRENT (TPS2062-Q1)							
Supply current, low-level output	No load on OUT, $V_{I(\overline{ENx})} = 5.5\text{ V}$	$T_A = 25^\circ\text{C}$		0.5	1	μA	
		$-40^\circ\text{C} \leq T_A \leq 125^\circ\text{C}$		0.5	5		
Supply current, high-level output	No load on OUT, $V_{I(\overline{ENx})} = 0\text{ V}$	$T_A = 25^\circ\text{C}$		50	70	μA	
		$-40^\circ\text{C} \leq T_A \leq 125^\circ\text{C}$		50	90		
Leakage current	OUT connected to ground, $V_{I(\overline{ENx})} = 5.5\text{ V}$	$-40^\circ\text{C} \leq T_A \leq 125^\circ\text{C}$			1	μA	
Reverse leakage current	$V_{I(OUTx)} = 5.5\text{ V}$, IN = ground	$T_A = 25^\circ\text{C}$			0.2	μA	
SUPPLY CURRENT (TPS2065-Q1)							
Supply current, low-level output	No load on OUT, $V_{I(\overline{ENx})} = 5.5\text{ V}$, or $V_{I(ENx)} = 0\text{ V}$	$T_A = 25^\circ\text{C}$		0.5	1	μA	
		$-40^\circ\text{C} \leq T_A \leq 125^\circ\text{C}$		0.5	5		
Supply current, high-level output	No load on OUT, $V_{I(\overline{ENx})} = 0\text{ V}$, or $V_{I(ENx)} = 5.5\text{ V}$	$T_A = 25^\circ\text{C}$		43	60	μA	
		$-40^\circ\text{C} \leq T_A \leq 125^\circ\text{C}$		43	70		
Leakage current	OUT connected to ground, $V_{I(\overline{EN})} = 5.5\text{ V}$, or $V_{I(EN)} = 0\text{ V}$	$-40^\circ\text{C} \leq T_A \leq 125^\circ\text{C}$			1	μA	
Reverse leakage current	$V_{I(OUTx)} = 5.5\text{ V}$, IN = ground	$T_A = 25^\circ\text{C}$			0	μA	
UNDERVOLTAGE LOCKOUT							
Low-level input voltage, IN				2		2.5	V
Hysteresis, IN		$T_A = 25^\circ\text{C}$			75		mV
OVERCURRENT $\overline{OC1}$ and $\overline{OC2}$							
Output low voltage, $V_{OL(OCx)}$		$I_{O(\overline{OCx})} = 5\text{ mA}$				0.4	V
Off-state current		$V_{O(\overline{OCx})} = 5\text{ V}$ or 3.3 V				1	μA
\overline{OC} deglitch ⁽²⁾		\overline{OCx} assertion or deassertion		4	8	15	ms
THERMAL SHUTDOWN⁽³⁾							
Thermal shutdown threshold				135			$^\circ\text{C}$
Recovery from thermal shutdown				125			$^\circ\text{C}$
Hysteresis					10		$^\circ\text{C}$

(1) Pulse-testing techniques maintain junction temperature close to ambient temperature; thermal effects must be taken into account separately.

(2) Not tested in production, specified by design.

(3) The thermal shutdown only reacts under overcurrent conditions.

DEVICE INFORMATION

Pin Functions - TPS2062-Q1

PINS		I/O	DESCRIPTION
TPS2062-Q1			
NAME	NO.		
$\overline{\text{EN1}}$	3	I	Enable input, logic low turns on power switch IN-OUT1
$\overline{\text{EN2}}$	4	I	Enable input, logic low turns on power switch IN-OUT2
EN1	-	I	Enable input, logic high turns on power switch IN-OUT1
EN2	-	I	Enable input, logic high turns on power switch IN-OUT2
GND	1		Ground
IN	2	I	Input voltage
$\overline{\text{OC1}}$	8	O	Overcurrent, open-drain output, active low, IN-OUT1
$\overline{\text{OC2}}$	5	O	Overcurrent, open-drain output, active low, IN-OUT2
OUT1	7	O	Power-switch output, IN-OUT1
OUT2	6	O	Power-switch output, IN-OUT2
PowerPAD™	-		Internally connected to GND; used to heat-sink the part to the circuit board traces. Should be connected to GND pin.

Functional Block Diagram - TPS2062-Q1

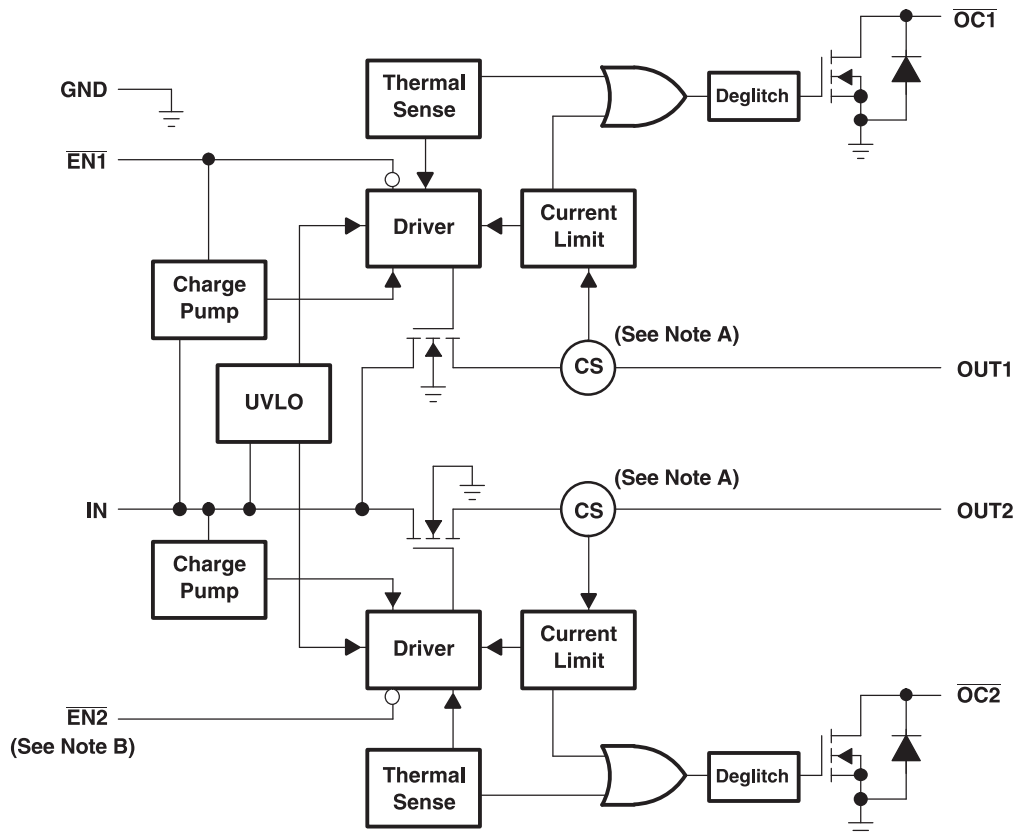

- A. Current sense
- B. Active low ($\overline{\text{EN}}$) for TPS2062-Q1

Pin Functions - TPS2065-Q1

PINS		I/O	DESCRIPTION
TPS2065-Q1			
NAME	NO.		
$\overline{\text{EN}}$	-	I	Enable input, logic low turns on power switch IN-OUT1
EN	4	I	Enable input, logic high turns on power switch IN-OUT1
GND	1		Ground
IN	2, 3	I	Input voltage
$\overline{\text{OC}}$	5	O	Overcurrent, open-drain output, active low, IN-OUT1
OUT	6, 7, 8	O	Power-switch output, IN-OUT1
PowerPAD™	-		Internally connected to GND; used to heat-sink the part to the circuit board traces. Should be connected to GND pin.

Functional Block Diagram - TPS2065-Q1

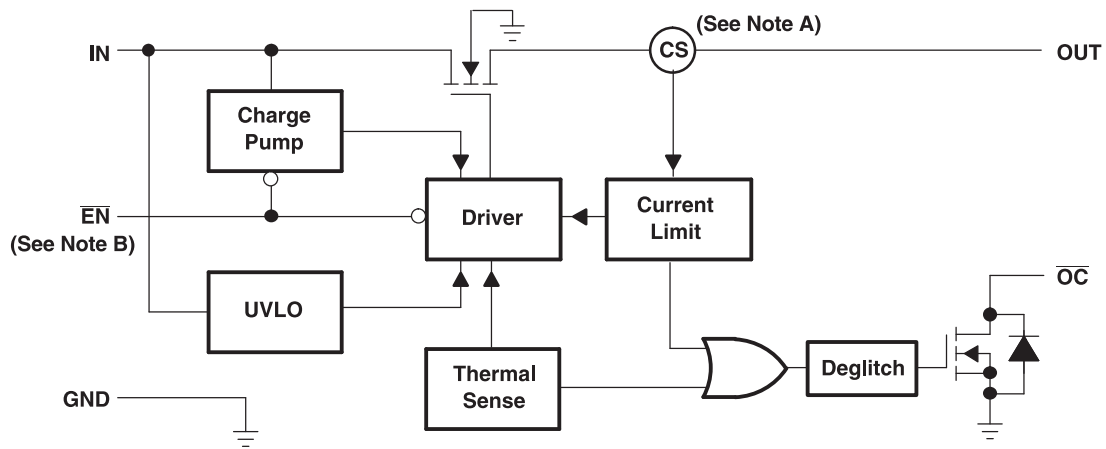

- A. Current sense
- B. Active high (EN) for TPS2065-Q1

PARAMETER MEASUREMENT INFORMATION

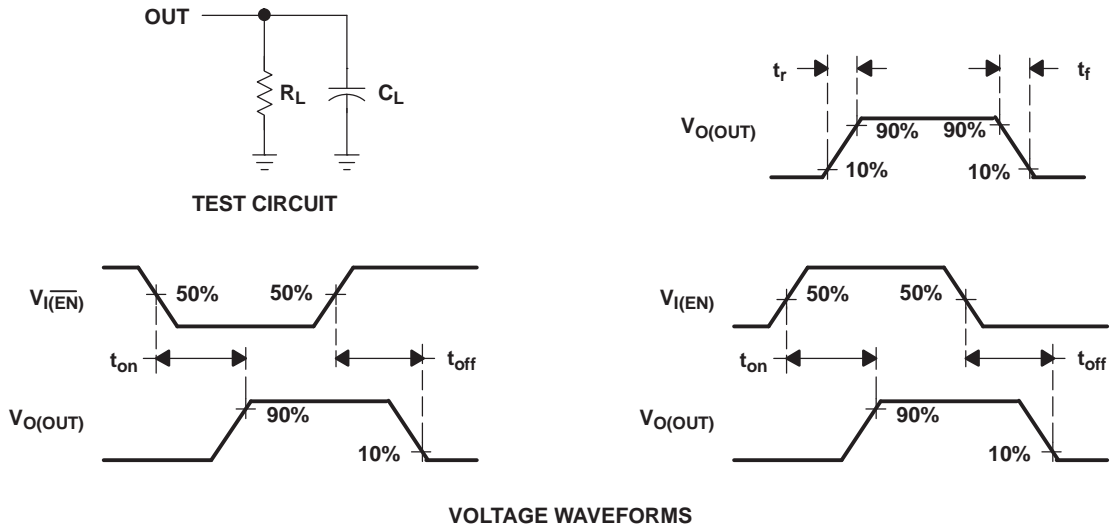

Figure 1. Test Circuit and Voltage Waveforms

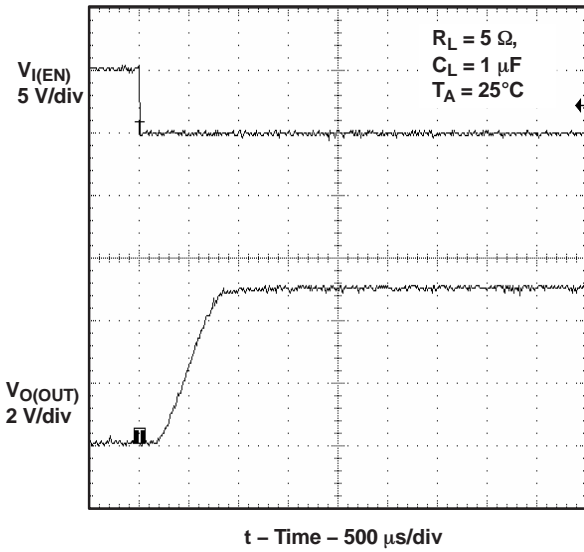

Figure 2. Turnon Delay and Rise Time With 1-µF Load

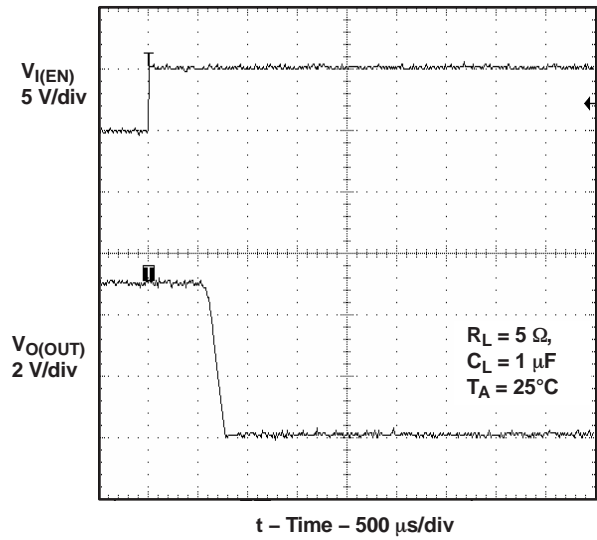

Figure 3. Turnoff Delay and Fall Time With 1-µF Load

PARAMETER MEASUREMENT INFORMATION (continued)

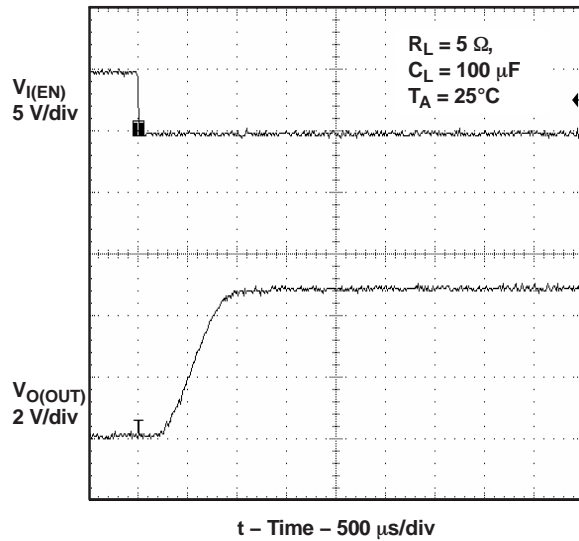

Figure 4. Turnon Delay and Rise Time With 100- μF Load

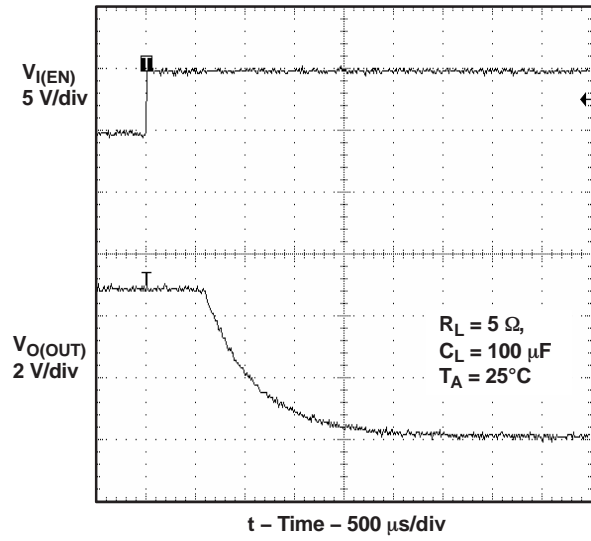

Figure 5. Turnoff Delay and Fall Time With 100- μF Load

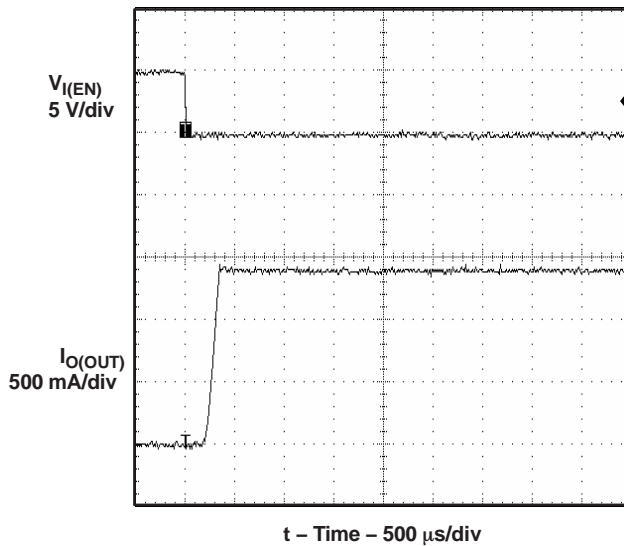

Figure 6. Short-Circuit Current, Device Enabled Into Short

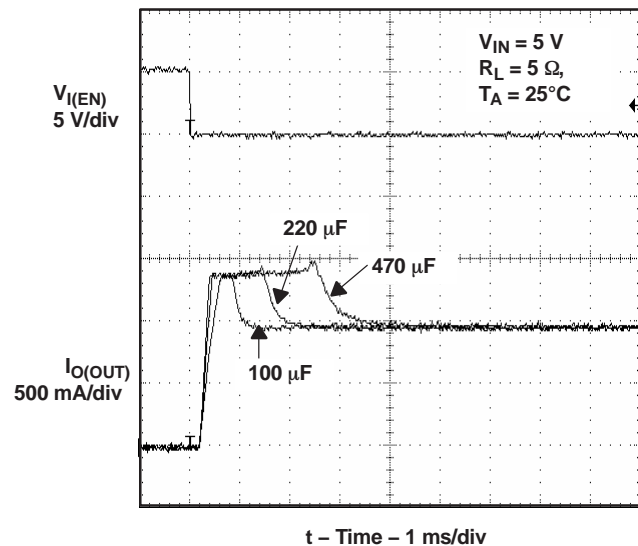

Figure 7. Inrush Current With Different Load Capacitance

PARAMETER MEASUREMENT INFORMATION (continued)

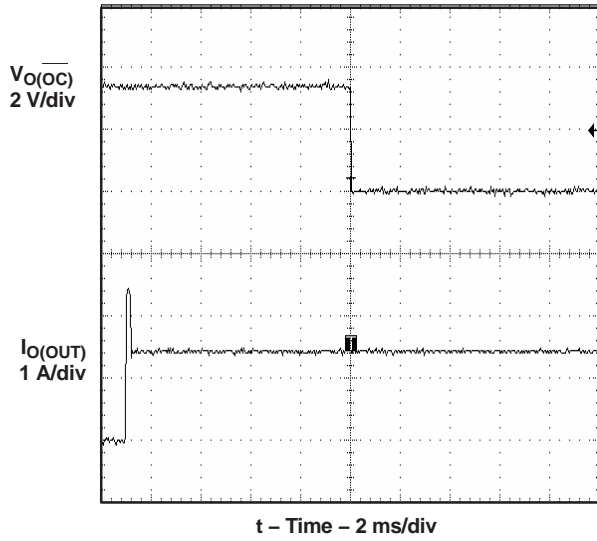

Figure 8. 2-Ω Load Connected to Enabled Device

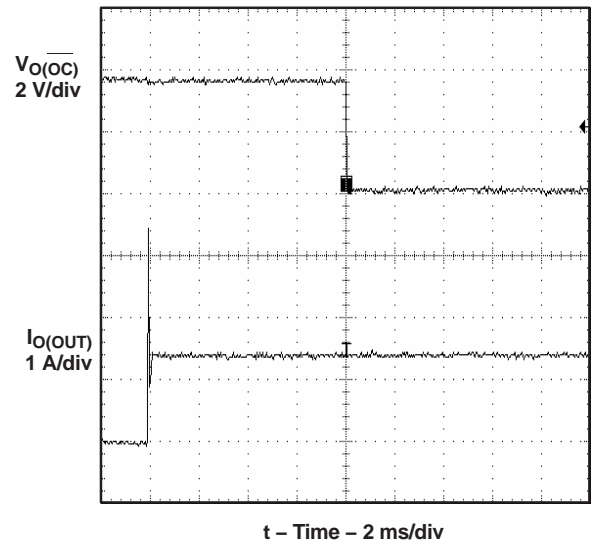

Figure 9. 1-Ω Load Connected to Enabled Device

TYPICAL CHARACTERISTICS

TURNON TIME
VS
INPUT VOLTAGE

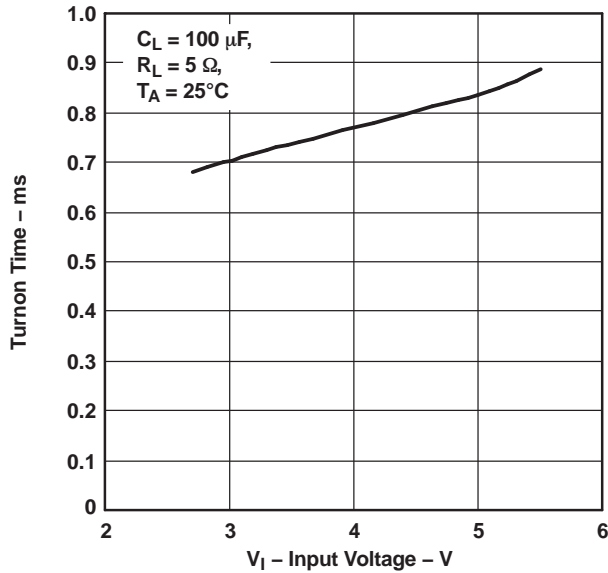

Figure 10.

TURNOFF TIME
VS
INPUT VOLTAGE

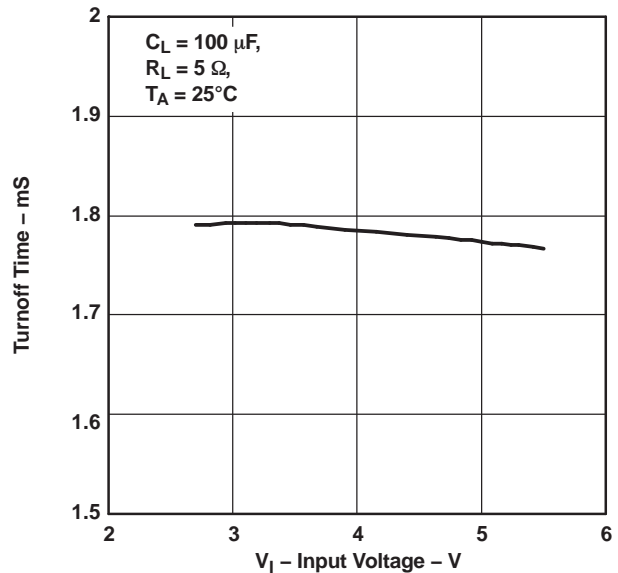

Figure 11.

TYPICAL CHARACTERISTICS (continued)

RISE TIME
vs
INPUT VOLTAGE

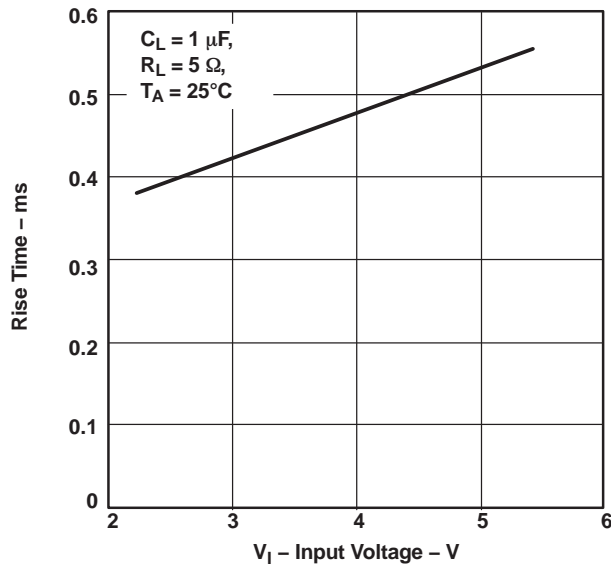

Figure 12.

FALL TIME
vs
INPUT VOLTAGE

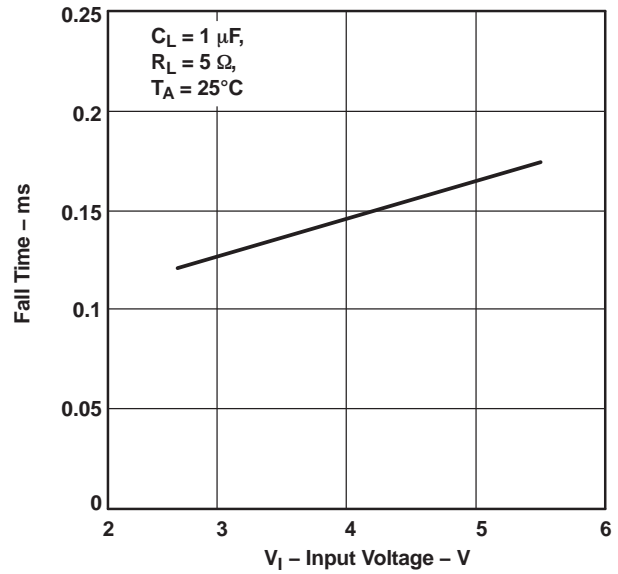

Figure 13.

TPS2062-Q1
SUPPLY CURRENT, OUTPUT ENABLED
vs
JUNCTION TEMPERATURE

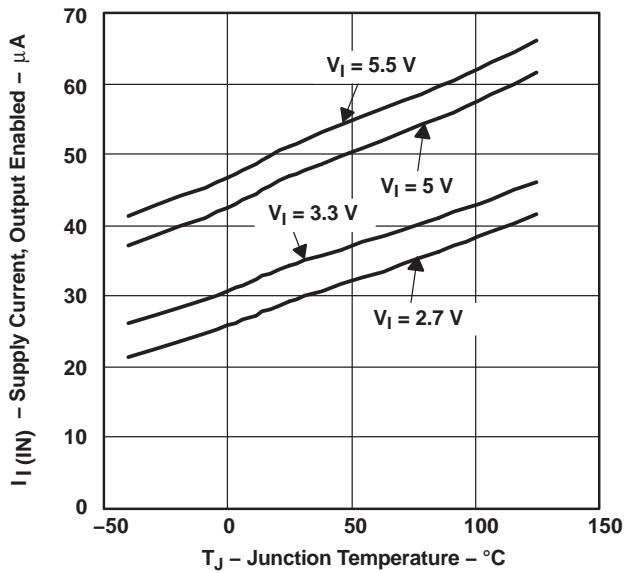

Figure 14.

TPS2065-Q1
SUPPLY CURRENT, OUTPUT ENABLED
vs
JUNCTION TEMPERATURE

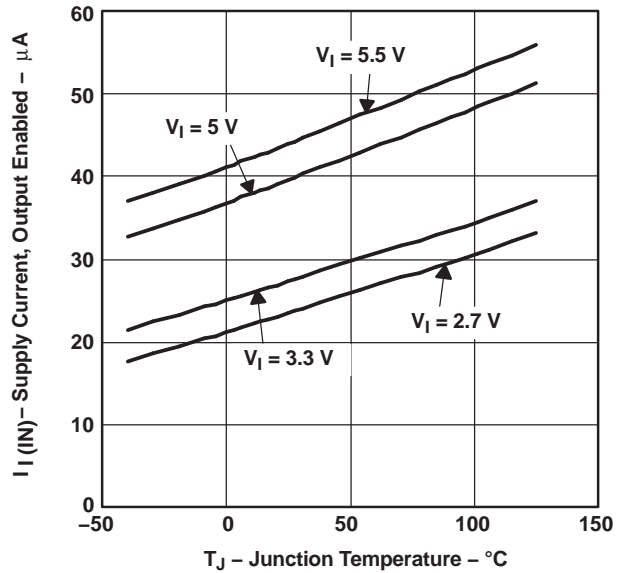

Figure 15.

TYPICAL CHARACTERISTICS (continued)

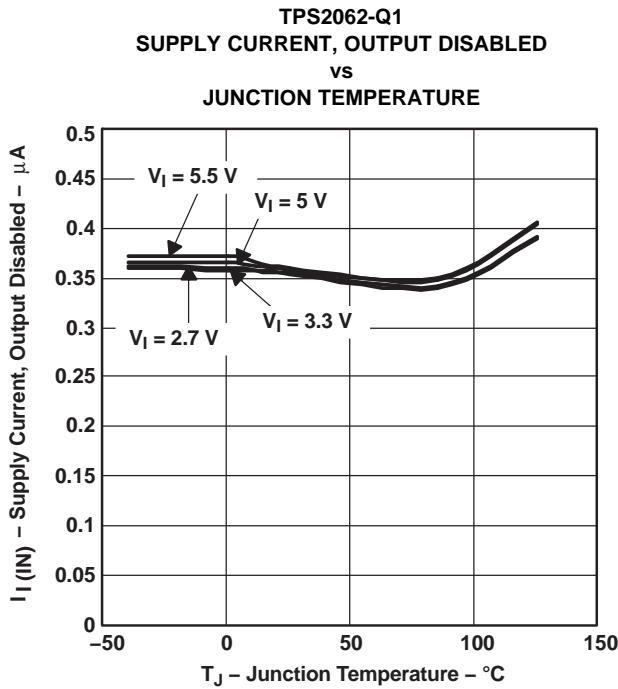

Figure 16.

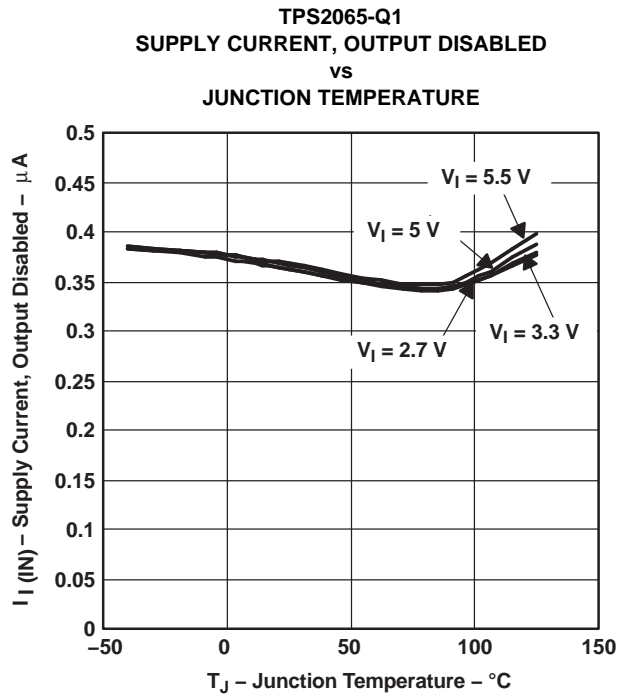

Figure 17.

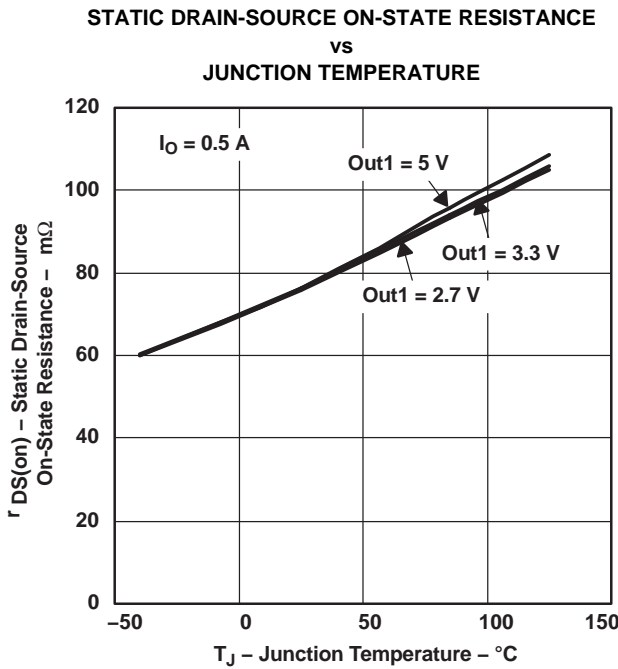

Figure 18.

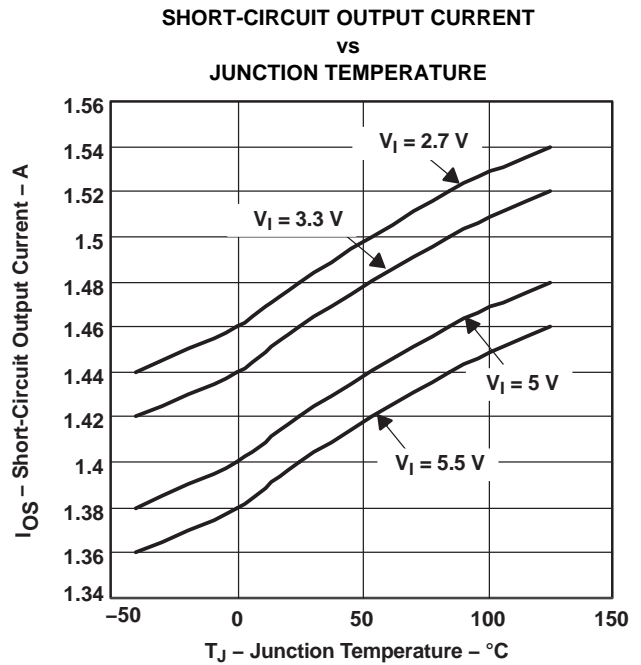

Figure 19.

TYPICAL CHARACTERISTICS (continued)

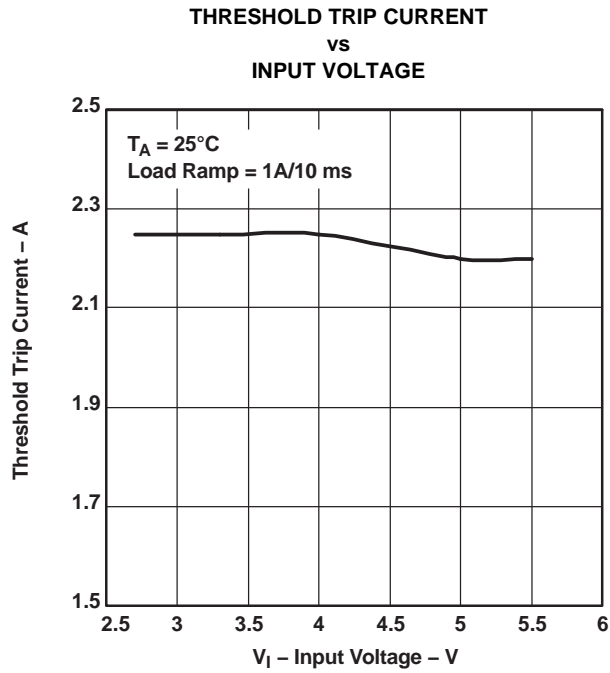

Figure 20.

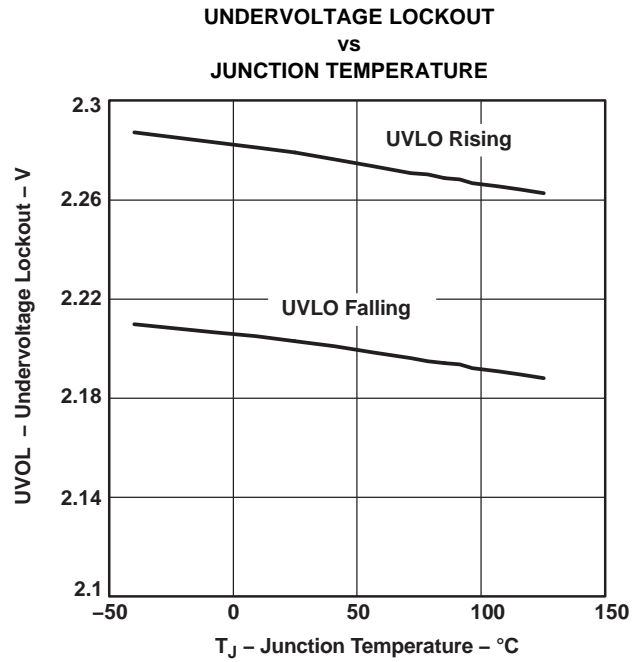

Figure 21.

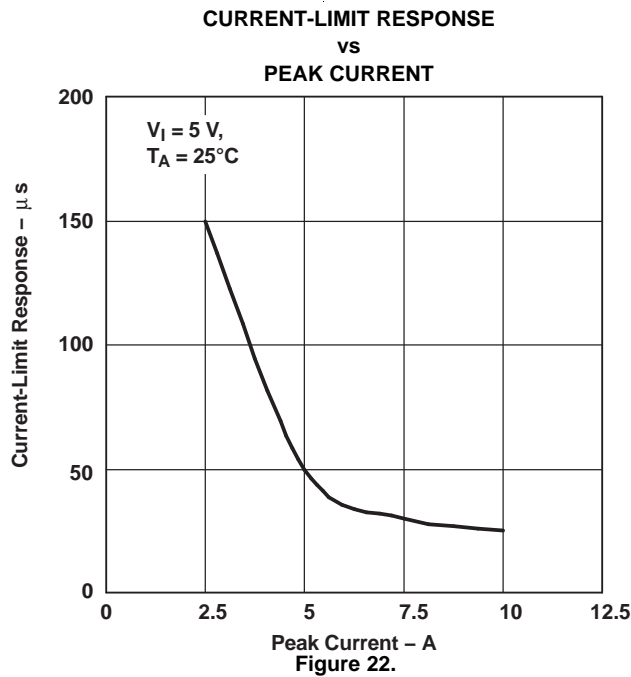

Figure 22.

APPLICATION INFORMATION

POWER-SUPPLY CONSIDERATIONS

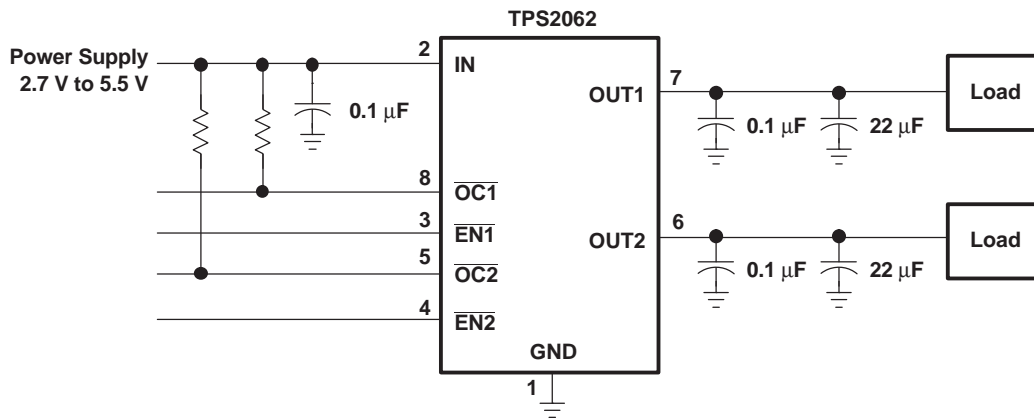

Figure 23. Typical Application

A 0.01- μF to 0.1- μF ceramic bypass capacitor between IN and GND, close to the device, is recommended. Placing a high-value electrolytic capacitor on the output pin(s) is recommended when the output load is heavy. This precaution reduces power-supply transients that may cause ringing on the input. Additionally, bypassing the output with a 0.01- μF to 0.1- μF ceramic capacitor improves the immunity of the device to short-circuit transients.

OVERCURRENT

A sense FET is employed to check for overcurrent conditions. Unlike current-sense resistors, sense FETs do not increase the series resistance of the current path. When an overcurrent condition is detected, the device maintains a constant output current and reduces the output voltage accordingly. Complete shutdown occurs only if the fault is present long enough to activate thermal limiting.

Three possible overload conditions can occur. In the first condition, the output has been shorted before the device is enabled or before $V_{I(IN)}$ has been applied (see Figure 14). The TPS206x-Q1 senses the short and immediately switches into a constant-current output.

In the second condition, a short or an overload occurs while the device is enabled. At the instant the overload occurs, high currents may flow for a short period of time before the current-limit circuit can react. After the current-limit circuit has tripped (reached the overcurrent trip threshold), the device switches into constant-current mode.

In the third condition, the load has been gradually increased beyond the recommended operating current. The current is permitted to rise until the current-limit threshold is reached or until the thermal limit of the device is exceeded (see Figure 16). The TPS2065-Q1 and TPS2062-Q1 are capable of delivering current up to the current-limit threshold without damaging the device. Once the threshold has been reached, the device switches into its constant-current mode.

$\overline{\text{OC}}$ RESPONSE

The $\overline{\text{OCx}}$ open-drain output is asserted (active low) when an overcurrent or overtemperature shutdown condition is encountered after a 10-ms deglitch timeout. The output remains asserted until the overcurrent or overtemperature condition is removed. Connecting a heavy capacitive load to an enabled device can cause a momentary overcurrent condition; however, no false reporting on $\overline{\text{OCx}}$ occurs due to the 10-ms deglitch circuit. The TPS2065-Q1 and TPS2062-Q1 are designed to eliminate false overcurrent reporting. The internal overcurrent deglitch eliminates the need for external components to remove unwanted pulses. $\overline{\text{OCx}}$ is not deglitched when the switch is turned off due to an overtemperature shutdown.

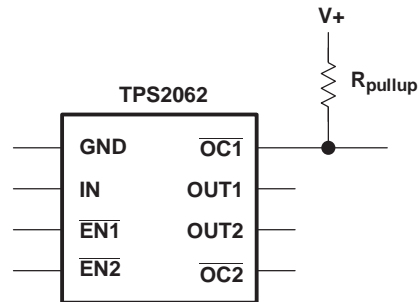

Figure 24. Typical Circuit for the \overline{OC} Pin

POWER DISSIPATION AND JUNCTION TEMPERATURE

The low on-resistance on the N-channel MOSFET allows the small surface-mount packages to pass large currents. The thermal resistances of these packages are high compared to those of power packages; it is good design practice to check power dissipation and junction temperature. Begin by determining the $r_{DS(on)}$ of the N-channel MOSFET relative to the input voltage and operating temperature. As an initial estimate, use the highest operating ambient temperature of interest and read $r_{DS(on)}$ from [Figure 18](#). Using this value, the power dissipation per switch can be calculated by:

- $P_D = r_{DS(on)} \times I^2$

Multiply this number by the number of switches being used. This step renders the total power dissipation from the N-channel MOSFETs.

The thermal resistance, $R_{\theta JA} = 1 / (\text{DERATING FACTOR})$, where DERATING FACTOR is obtained from the [Dissipation Ratings Table](#). Thermal resistance is a strong function of the printed circuit board construction, and the copper trace area connecting the integrated circuit.

Finally, calculate the junction temperature:

- $T_J = P_D \times R_{\theta JA} + T_A$

Where:

- T_A = Ambient temperature °C
- $R_{\theta JA}$ = Thermal resistance
- P_D = Total power dissipation based on number of switches being used.

Compare the calculated junction temperature with the initial estimate. If they do not agree within a few degrees, repeat the calculation, using the calculated value as the new estimate. Two or three iterations are generally sufficient to get a reasonable answer.

THERMAL PROTECTION

Thermal protection prevents damage to the IC when heavy-overload or short-circuit faults are present for extended periods of time. The TPS2065-Q1 and TPS2062-Q1 implement a thermal sensing to monitor the operating junction temperature of the power distribution switch. In an overcurrent or short-circuit condition, the junction temperature rises due to excessive power dissipation. Once the die temperature rises above a minimum of 135°C due to overcurrent conditions, the internal thermal sense circuitry turns the power switch off, thus preventing the power switch from damage. Hysteresis is built into the thermal sense circuit, and after the device has cooled approximately 10°C, the switch turns back on. The switch continues to cycle in this manner until the load fault or input power is removed. The \overline{OCx} open-drain output is asserted (active low) when an overtemperature shutdown or overcurrent occurs.

UNDERVOLTAGE LOCKOUT (UVLO)

An undervoltage lockout ensures that the power switch is in the off state at power up. Whenever the input voltage falls below approximately 2 V, the power switch is quickly turned off. This facilitates the design of hot-insertion systems where it is not possible to turn off the power switch before input power is removed. The UVLO also keeps the switch from being turned on until the power supply has reached at least 2 V, even if the switch is enabled. On reinsertion, the power switch is turned on, with a controlled rise time to reduce EMI and voltage overshoots.

UNIVERSAL SERIAL BUS (USB) APPLICATIONS

The universal serial bus (USB) interface is a 12-Mb/s, or 1.5-Mb/s, multiplexed serial bus designed for low-to-medium bandwidth PC peripherals (e.g., keyboards, printers, scanners, and mice). The four-wire USB interface is conceived for dynamic attach-detach (hot plug-unplug) of peripherals. Two lines are provided for differential data, and two lines are provided for 5-V power distribution.

USB data is a 3.3-V level signal, but power is distributed at 5 V to allow for voltage drops in cases where power is distributed through more than one hub across long cables. Each function must provide its own regulated 3.3 V from the 5-V input or its own internal power supply.

The USB specification defines the following five classes of devices, each differentiated by power-consumption requirements:

- Hosts/self-powered hubs (SPH)
- Bus-powered hubs (BPH)
- Low-power, bus-powered functions
- High-power, bus-powered functions
- Self-powered functions

SPHs and BPHs distribute data and power to downstream functions. The TPS2065-Q1 and TPS2062-Q1 have higher current capability than required by one USB port; so, it can be used on the host side and supplies power to multiple downstream ports or functions.

HOST/SELF-POWERED AND BUS-POWERED HUBS

Hosts and SPHs have a local power supply that powers the embedded functions and the downstream ports (see [Figure 25](#)). This power supply must provide from 5.25 V to 4.75 V to the board side of the downstream connection under full-load and no-load conditions. Hosts and SPHs are required to have current-limit protection and must report overcurrent conditions to the USB controller. Typical SPHs are desktop PCs, monitors, printers, and stand-alone hubs.

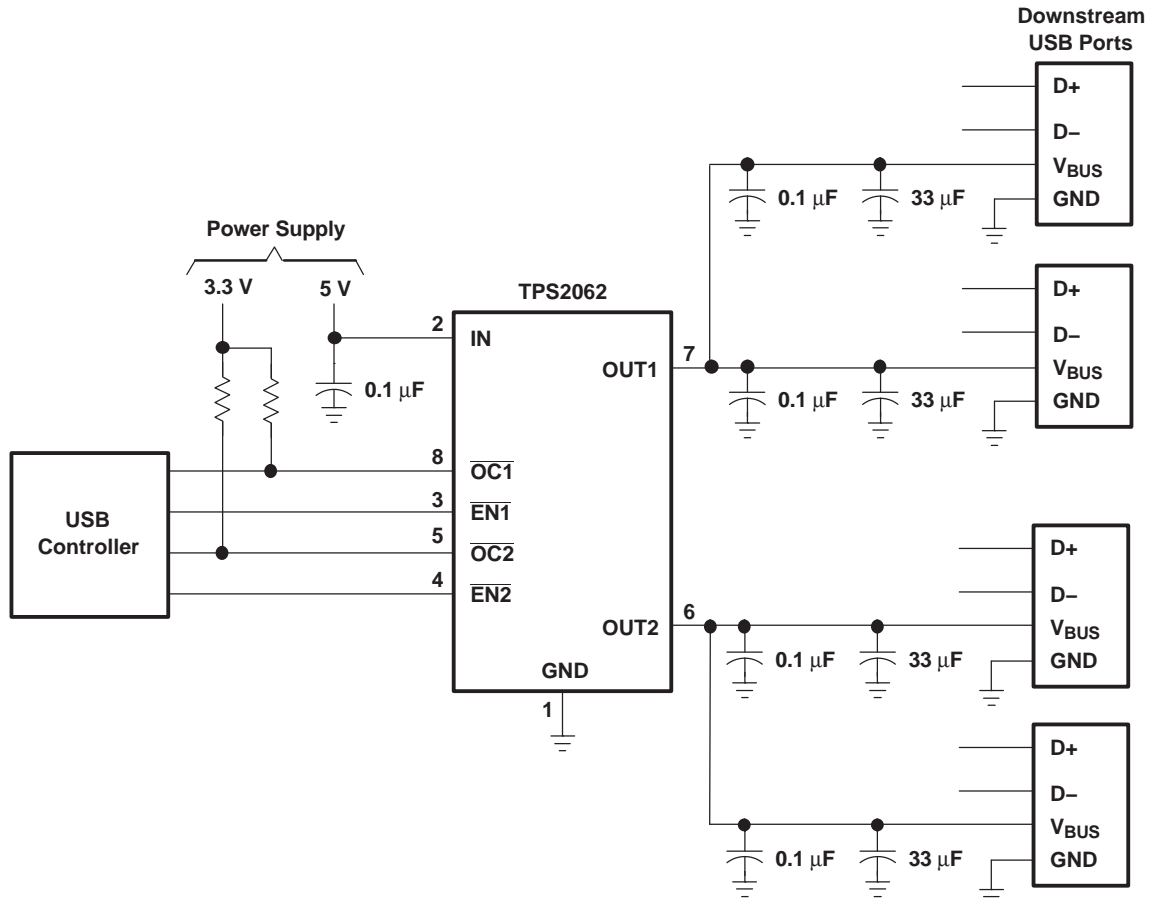

Figure 25. Typical Four-Port USB Host / Self-Powered Hub

BPHs obtain all power from upstream ports and often contain an embedded function. The hubs are required to power up with less than one unit load. The BPH usually has one embedded function, and power is always available to the controller of the hub. If the embedded function and hub require more than 100 mA on power up, the power to the embedded function may need to be kept off until enumeration is completed. This can be accomplished by removing power or by shutting off the clock to the embedded function. Power switching the embedded function is not necessary if the aggregate power draw for the function and controller is less than one unit load. The total current drawn by the bus-powered device is the sum of the current to the controller, the embedded function, and the downstream ports, and it is limited to 500 mA from an upstream port.

LOW-POWER BUS-POWERED AND HIGH-POWER BUS-POWERED FUNCTIONS

Both low-power and high-power bus-powered functions obtain all power from upstream ports; low-power functions always draw less than 100 mA; high-power functions must draw less than 100 mA at power up and can draw up to 500 mA after enumeration. If the load of the function is more than the parallel combination of 44 Ω and 10 μF at power up, the device must implement inrush current limiting (see Figure 26). With TPS2065-Q1 and TPS2062-Q1, the internal functions could draw more than 500 mA, which fits the needs of some applications such as motor driving circuits.

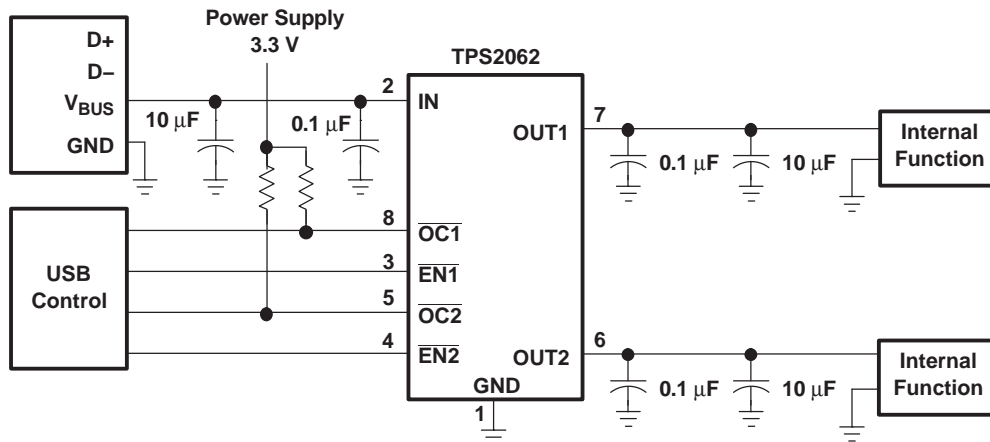

Figure 26. High-Power Bus-Powered Function

USB POWER-DISTRIBUTION REQUIREMENTS

USB can be implemented in several ways, and, regardless of the type of USB device being developed, several power-distribution features must be implemented.

- Hosts/SPHs must:
 - Current-limit downstream ports
 - Report overcurrent conditions on USB V_{BUS}
- BPHs must:
 - Enable/disable power to downstream ports
 - Power up at <100 mA
 - Limit inrush current (<44 Ω and 10 μF)
- Functions must:
 - Limit inrush currents
 - Power up at <100 mA

The feature set of the TPS2065-Q1 and TPS2062-Q1 allows them to meet each of these requirements. The integrated current-limiting and overcurrent reporting is required by hosts and self-powered hubs. The logic-level enable and controlled rise times meet the need of both input and output ports on bus-powered hubs, as well as the input ports for bus-powered functions (see [Figure 27](#)).

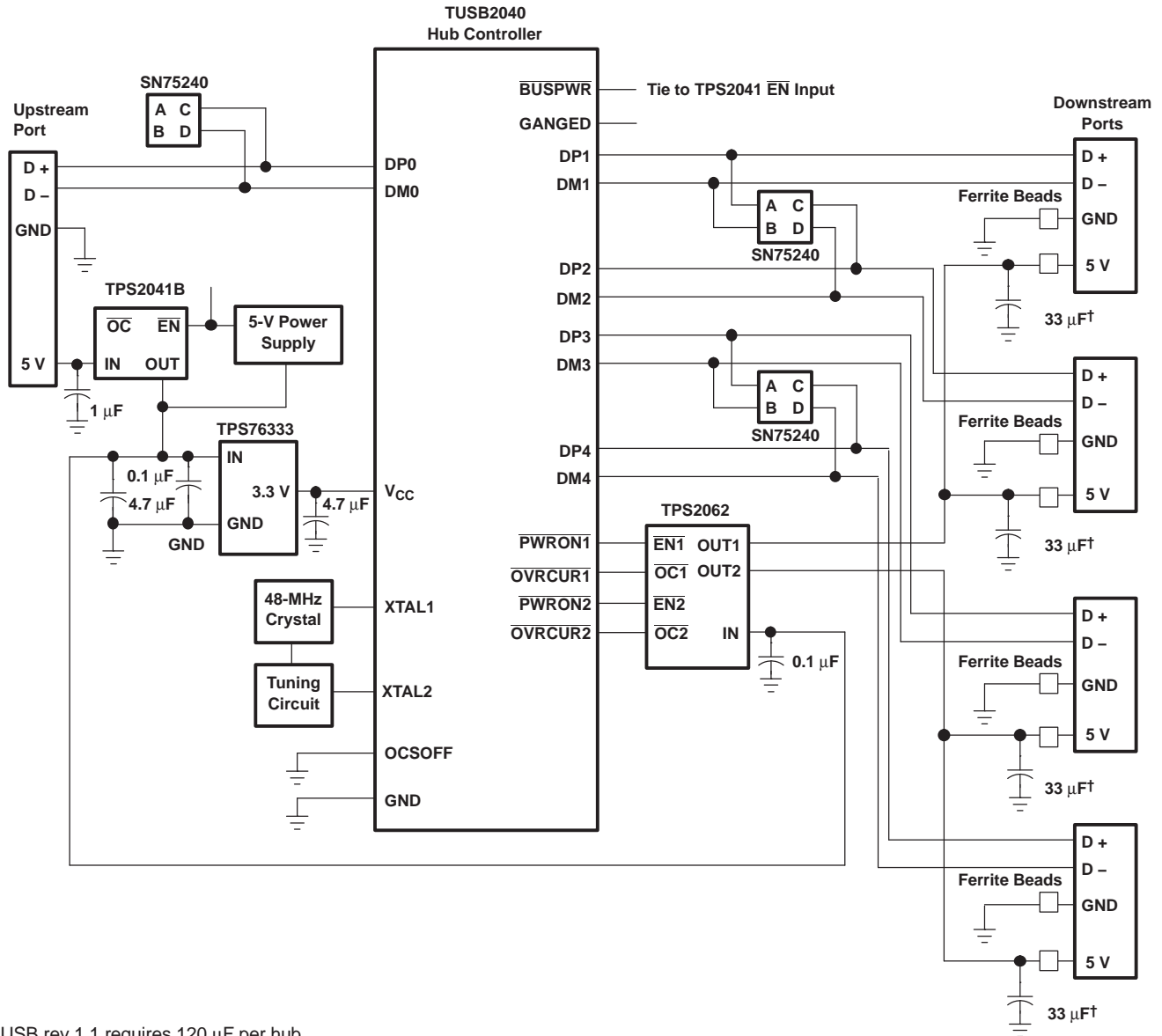

† USB rev 1.1 requires 120 µF per hub.

Figure 27. Hybrid Self / Bus-Powered Hub Implementation

GENERIC HOT-PLUG APPLICATIONS

In many applications it may be necessary to remove modules or pc boards while the main unit is still operating. These are considered hot-plug applications. Such implementations require the control of current surges seen by the main power supply and the card being inserted. The most effective way to control these surges is to limit and slowly ramp the current and voltage being applied to the card, similar to the way in which a power supply normally turns on. Due to the controlled rise times and fall times of the TPS2065-Q1 and TPS2062-Q1, these devices can be used to provide a softer start-up to devices being hot-plugged into a powered system. The UVLO feature of the TPS2065-Q1 and TPS2062-Q1 ensures that the switch is off after the card has been removed, and that the switch is off during the next insertion. The UVLO feature insures a soft start with a controlled rise time for every insertion of the card or module.

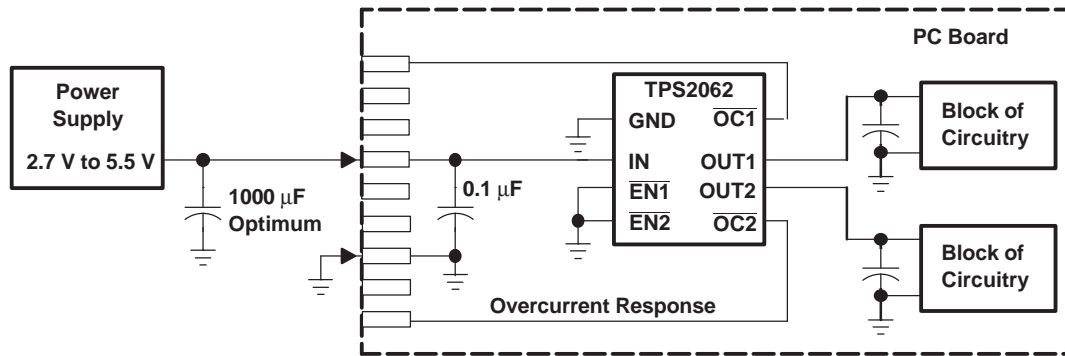

Figure 28. Typical Hot-Plug Implementation

By placing the TPS2065-Q1 and TPS2062-Q1 are between the V_{CC} input and the rest of the circuitry, the input power reaches these devices first after insertion. The typical rise time of the switch is approximately 1 ms, providing a slow voltage ramp at the output of the device. This implementation controls system surge currents and provides a hot-plugging mechanism for any device.

DETAILED DESCRIPTION

Power Switch

The power switch is an N-channel MOSFET with a low on-state resistance. Configured as a high-side switch, the power switch prevents current flow from OUT to IN and IN to OUT when disabled. The power switch supplies a minimum current of 1 A.

Charge Pump

An internal charge pump supplies power to the driver circuit and provides the necessary voltage to pull the gate of the MOSFET above the source. The charge pump operates from input voltages as low as 2.7 V and requires little supply current.

Driver

The driver controls the gate voltage of the power switch. To limit large current surges and reduce the associated electromagnetic interference (EMI) produced, the driver incorporates circuitry that controls the rise times and fall times of the output voltage.

Enable (\overline{ENx})

The logic enable disables the power switch and the bias for the charge pump, driver, and other circuitry to reduce the supply current. The supply current is reduced to less than 1 μA when a logic high is present on \overline{ENx} . A logic zero input on \overline{ENx} restores bias to the drive and control circuits and turns the switch on. The enable input is compatible with both TTL and CMOS logic levels.

Overcurrent (\overline{OCx})

The \overline{OCx} open-drain output is asserted (active low) when an overcurrent or overtemperature condition is encountered. The output remains asserted until the overcurrent or overtemperature condition is removed. A 10-ms deglitch circuit prevents the \overline{OCx} signal from oscillation or false triggering. If an overtemperature shutdown occurs, the \overline{OCx} is asserted instantaneously.

Current Sense

A sense FET monitors the current supplied to the load. The sense FET measures current more efficiently than conventional resistance methods. When an overload or short circuit is encountered, the current-sense circuitry sends a control signal to the driver. The driver in turn reduces the gate voltage and drives the power FET into its saturation region, which switches the output into a constant-current mode and holds the current constant while varying the voltage on the load.

Thermal Sense

The TPS2065-Q1 and TPS2062-Q1 implement a thermal sensing to monitor the operating temperature of the power distribution switch. In an overcurrent or short-circuit condition the junction temperature rises. When the die temperature rises to approximately 140°C due to overcurrent conditions, the internal thermal sense circuitry turns off the switch, thus preventing the device from damage. Hysteresis is built into the thermal sense, and after the device has cooled approximately 10 degrees, the switch turns back on. The switch continues to cycle off and on until the fault is removed. The open-drain false reporting output (\overline{OCx}) is asserted (active low) when an overtemperature shutdown or overcurrent occurs.

Undervoltage Lockout

A voltage sense circuit monitors the input voltage. When the input voltage is below approximately 2 V, a control signal turns off the power switch.

REVISION HISTORY

Changes from Revision A (November 2011) to Revision B	Page
• 经更改的包括使能 (EN) 引脚的引脚分配图。	1
• Added or EN to Electrical Characteristics table.	3

PACKAGING INFORMATION

Orderable Device	Status (1)	Package Type	Package Drawing	Pins	Package Qty	Eco Plan (2)	Lead finish/ Ball material (6)	MSL Peak Temp (3)	Op Temp (°C)	Device Marking (4/5)	Samples
TPS2062QDGNRQ1	ACTIVE	HVSSOP	DGN	8	2500	RoHS & Green	NIPDAU	Level-2-260C-1 YEAR	-40 to 125	PSOQ	Samples
TPS2065QDGNRQ1	ACTIVE	HVSSOP	DGN	8	2500	RoHS & Green	NIPDAU	Level-2-260C-1 YEAR	-40 to 150	PTLQ	Samples

(1) The marketing status values are defined as follows:

ACTIVE: Product device recommended for new designs.

LIFEBUY: TI has announced that the device will be discontinued, and a lifetime-buy period is in effect.

NRND: Not recommended for new designs. Device is in production to support existing customers, but TI does not recommend using this part in a new design.

PREVIEW: Device has been announced but is not in production. Samples may or may not be available.

OBSELETE: TI has discontinued the production of the device.

(2) **RoHS:** TI defines "RoHS" to mean semiconductor products that are compliant with the current EU RoHS requirements for all 10 RoHS substances, including the requirement that RoHS substance do not exceed 0.1% by weight in homogeneous materials. Where designed to be soldered at high temperatures, "RoHS" products are suitable for use in specified lead-free processes. TI may reference these types of products as "Pb-Free".

RoHS Exempt: TI defines "RoHS Exempt" to mean products that contain lead but are compliant with EU RoHS pursuant to a specific EU RoHS exemption.

Green: TI defines "Green" to mean the content of Chlorine (Cl) and Bromine (Br) based flame retardants meet JS709B low halogen requirements of <=1000ppm threshold. Antimony trioxide based flame retardants must also meet the <=1000ppm threshold requirement.

(3) MSL, Peak Temp. - The Moisture Sensitivity Level rating according to the JEDEC industry standard classifications, and peak solder temperature.

(4) There may be additional marking, which relates to the logo, the lot trace code information, or the environmental category on the device.

(5) Multiple Device Markings will be inside parentheses. Only one Device Marking contained in parentheses and separated by a "~" will appear on a device. If a line is indented then it is a continuation of the previous line and the two combined represent the entire Device Marking for that device.

(6) Lead finish/Ball material - Orderable Devices may have multiple material finish options. Finish options are separated by a vertical ruled line. Lead finish/Ball material values may wrap to two lines if the finish value exceeds the maximum column width.

Important Information and Disclaimer:The information provided on this page represents TI's knowledge and belief as of the date that it is provided. TI bases its knowledge and belief on information provided by third parties, and makes no representation or warranty as to the accuracy of such information. Efforts are underway to better integrate information from third parties. TI has taken and continues to take reasonable steps to provide representative and accurate information but may not have conducted destructive testing or chemical analysis on incoming materials and chemicals. TI and TI suppliers consider certain information to be proprietary, and thus CAS numbers and other limited information may not be available for release.

In no event shall TI's liability arising out of such information exceed the total purchase price of the TI part(s) at issue in this document sold by TI to Customer on an annual basis.

OTHER QUALIFIED VERSIONS OF TPS2062-Q1, TPS2065-Q1 :

- Catalog : [TPS2062](#), [TPS2065](#)

NOTE: Qualified Version Definitions:

- Catalog - TI's standard catalog product

TAPE AND REEL INFORMATION

QUADRANT ASSIGNMENTS FOR PIN 1 ORIENTATION IN TAPE

*All dimensions are nominal

Device	Package Type	Package Drawing	Pins	SPQ	Reel Diameter (mm)	Reel Width W1 (mm)	A0 (mm)	B0 (mm)	K0 (mm)	P1 (mm)	W (mm)	Pin1 Quadrant
TPS2062QDGNRQ1	HVSSOP	DGN	8	2500	330.0	12.4	5.3	3.3	1.3	8.0	12.0	Q1
TPS2065QDGNRQ1	HVSSOP	DGN	8	2500	330.0	12.4	5.3	3.3	1.3	8.0	12.0	Q1

TAPE AND REEL BOX DIMENSIONS

*All dimensions are nominal

Device	Package Type	Package Drawing	Pins	SPQ	Length (mm)	Width (mm)	Height (mm)
TPS2062QDGNRQ1	HVSSOP	DGN	8	2500	367.0	367.0	38.0
TPS2065QDGNRQ1	HVSSOP	DGN	8	2500	367.0	367.0	38.0

GENERIC PACKAGE VIEW

DGN 8

PowerPAD™ HVSSOP - 1.1 mm max height

3 x 3, 0.65 mm pitch

SMALL OUTLINE PACKAGE

This image is a representation of the package family, actual package may vary.
Refer to the product data sheet for package details.

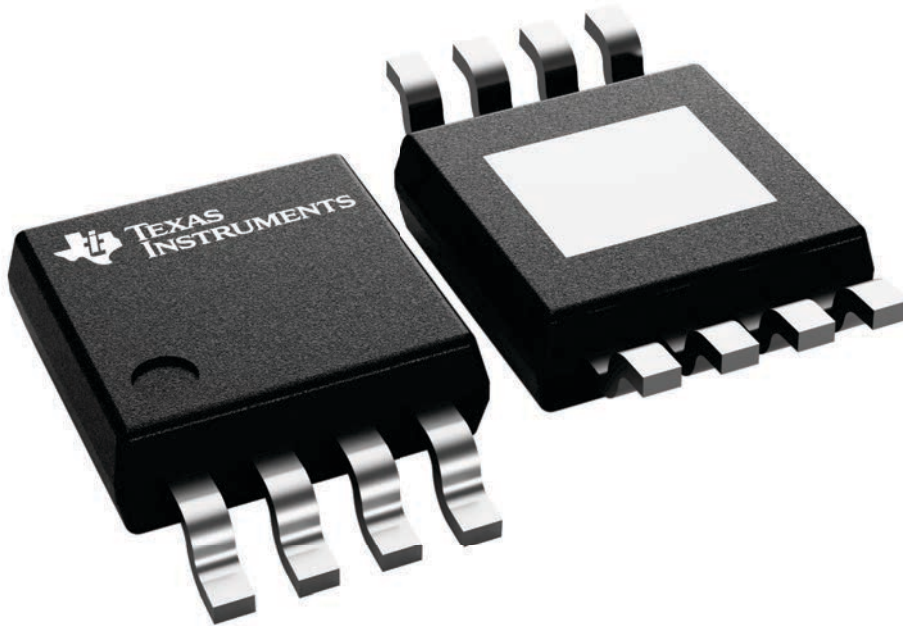

4225482/B

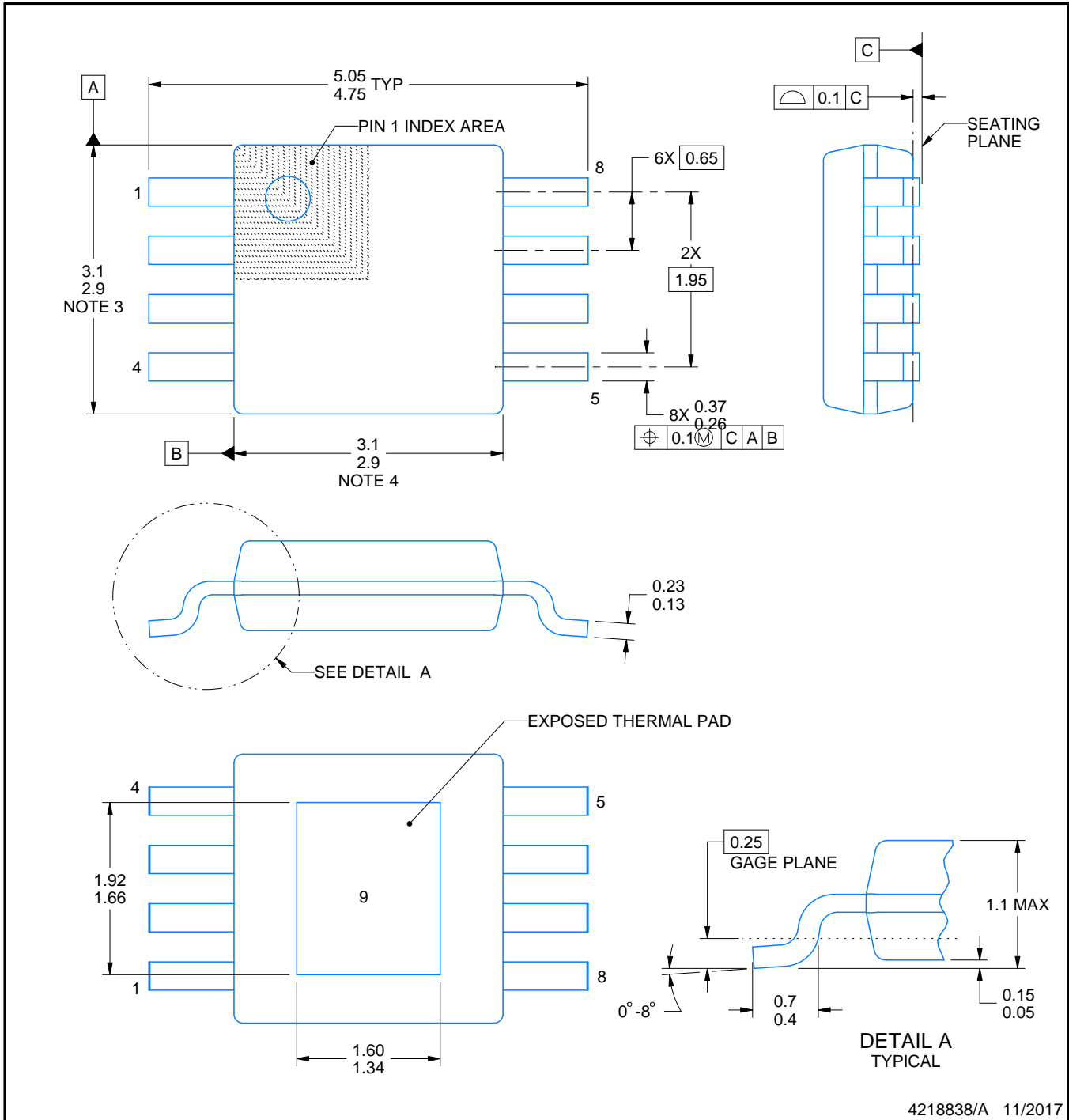
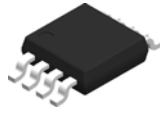

4218838/A 11/2017

NOTES:

1. All linear dimensions are in millimeters. Any dimensions in parenthesis are for reference only. Dimensioning and tolerancing per ASME Y14.5M.
2. This drawing is subject to change without notice.
3. This dimension does not include mold flash, protrusions, or gate burrs. Mold flash, protrusions, or gate burrs shall not exceed 0.15 mm per side.
4. This dimension does not include interlead flash. Interlead flash shall not exceed 0.25 mm per side.
5. Reference JEDEC registration MO-187.

EXAMPLE BOARD LAYOUT

DGN0008C

HVSSOP - 1.1 mm max height

SMALL OUTLINE PACKAGE

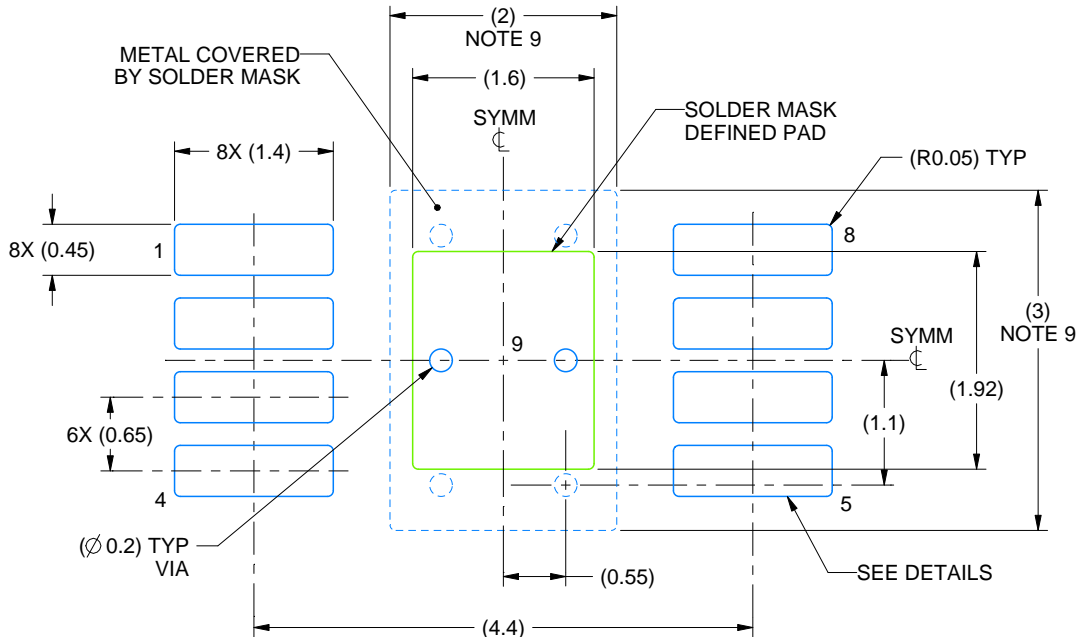

LAND PATTERN EXAMPLE
EXPOSED METAL SHOWN
SCALE: 15X



SOLDER MASK DETAILS

4218838/A 11/2017

NOTES: (continued)

6. Publication IPC-7351 may have alternate designs.
7. Solder mask tolerances between and around signal pads can vary based on board fabrication site.
8. Vias are optional depending on application, refer to device data sheet. If any vias are implemented, refer to their locations shown on this view. It is recommended that vias under paste be filled, plugged or tented.
9. Size of metal pad may vary due to creepage requirement.

EXAMPLE STENCIL DESIGN

DGN0008C

HVSSOP - 1.1 mm max height

SMALL OUTLINE PACKAGE

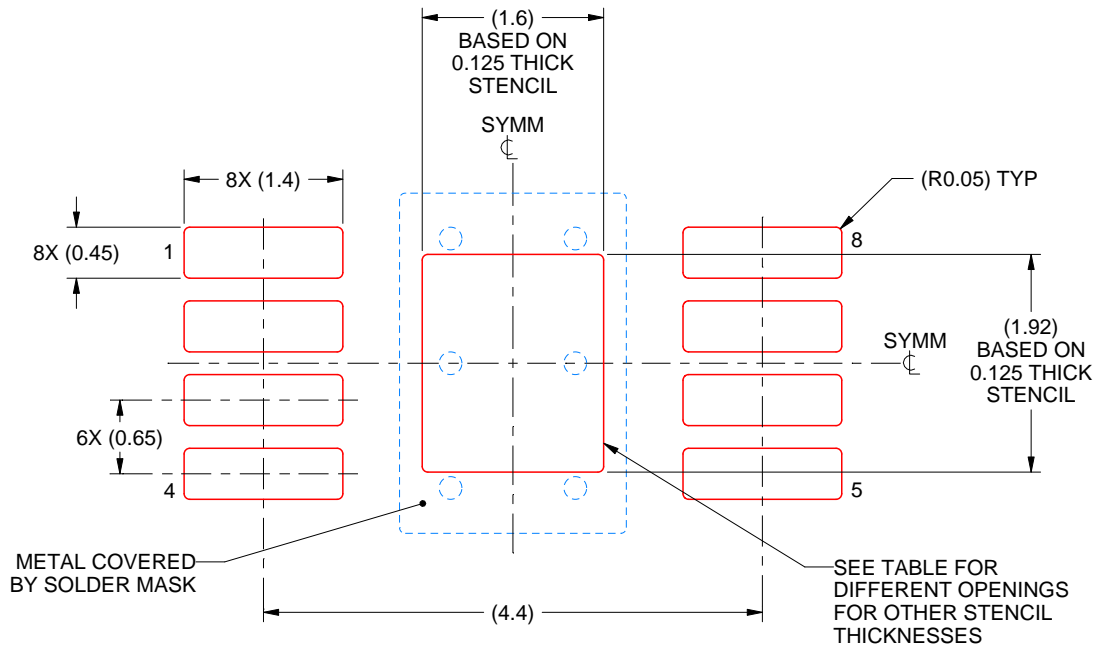

SOLDER PASTE EXAMPLE
 EXPOSED PAD 9:
 100% PRINTED SOLDER COVERAGE BY AREA
 SCALE: 15X

STENCIL THICKNESS	SOLDER STENCIL OPENING
0.1	1.79 X 2.15
0.125	1.60 X 1.92 (SHOWN)
0.15	1.46 X 1.75
0.175	1.35 X 1.62

4218838/A 11/2017

NOTES: (continued)

10. Laser cutting apertures with trapezoidal walls and rounded corners may offer better paste release. IPC-7525 may have alternate design recommendations.
11. Board assembly site may have different recommendations for stencil design.

重要声明和免责声明

TI“按原样”提供技术和可靠性数据（包括数据表）、设计资源（包括参考设计）、应用或其他设计建议、网络工具、安全信息和其他资源，不保证没有瑕疵且不做任何明示或暗示的担保，包括但不限于对适销性、某特定用途方面的适用性或不侵犯任何第三方知识产权的暗示担保。

这些资源可供使用 TI 产品进行设计的熟练开发人员使用。您将自行承担以下全部责任：(1) 针对您的应用选择合适的 TI 产品，(2) 设计、验证并测试您的应用，(3) 确保您的应用满足相应标准以及任何其他功能安全、信息安全、监管或其他要求。

这些资源如有变更，恕不另行通知。TI 授权您仅可将这些资源用于研发本资源所述的 TI 产品的应用。严禁对这些资源进行其他复制或展示。您无权使用任何其他 TI 知识产权或任何第三方知识产权。您应全额赔偿因在这些资源的使用中对 TI 及其代表造成的任何索赔、损害、成本、损失和债务，TI 对此概不负责。

TI 提供的产品受 [TI 的销售条款](#) 或 [ti.com](#) 上其他适用条款/TI 产品随附的其他适用条款的约束。TI 提供这些资源并不会扩展或以其他方式更改 TI 针对 TI 产品发布的适用的担保或担保免责声明。

TI 反对并拒绝您可能提出的任何其他或不同的条款。

邮寄地址：Texas Instruments, Post Office Box 655303, Dallas, Texas 75265

Copyright © 2024，德州仪器 (TI) 公司