

具有手动和优先级切换功能的 TPS2116 1.6V 至 5.5V、2.5A 低 I_Q 电源多路复用器

1 特性

- 输入电压范围：1.6V 至 5.5V
- 最大持续电流：2.5A
- 导通电阻：40m Ω (典型值)
- VIN2 待机电流：50nA (典型值)
- 静态电流：1.32 μ A (典型值)
- 切换模式：
 - 优先级模式
 - 手动模式
- 受控输出压摆率：
 - 电压为 3.3V 时为 1.3ms (典型值)
- VOUT 大于 VINx 时实现反向电流阻断
- 热关断

2 应用

- 备用电池系统
- 电表
- 电机驱动器
- 楼宇自动化

3 说明

TPS2116 是一款电源多路复用器，具有 1.6V 至 5.5V 的额定电压和 2.5A 的最大额定电流。该器件使用 N 沟道 MOSFET 在电源之间切换，同时在第一次施加电压时提供受控的压摆率。

凭借 1.32 μ A (典型值) 的低静态电流和 50nA (典型值) 的低待机电流，TPS2116 适用于其中一个输入由电池供电的系统。这些低电流延长了电池的使用寿命和续航时间。

TPS2116 可根据应用配置用于两种不同的切换操作。自动优先级模式优先选择连接到 VIN1 的电源，在 VIN1 下降时将切换到次级电源 (VIN2)。手动模式允许用户切换 GPIO 或使信号能够在通道之间切换。

器件信息(1)

器件型号	封装	封装尺寸 (标称值)
TPS2116	SOT (8)	2.1mm x 1.6mm

(1) 如需了解所有可用封装，请参阅数据表末尾的可订购产品附录。

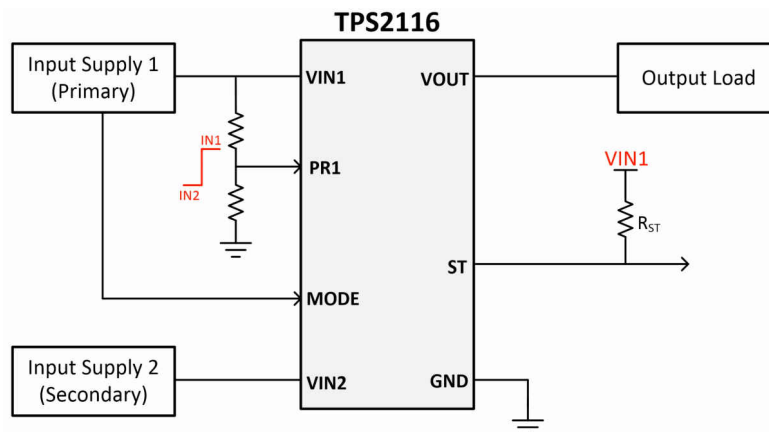

基本应用



Table of Contents

1 特性	1	7.4 VINx Collapse Rate.....	11
2 应用	1	7.5 Output Voltage Drop.....	12
3 说明	1	7.6 Device Functional Modes.....	12
4 Revision History	2	8 Application and Implementation	14
5 Pin Configuration and Functions	3	8.1 Application Information.....	14
6 Specifications	4	8.2 Typical Application.....	14
6.1 Absolute Maximum Ratings	4	9 Power Supply Recommendations	16
6.2 ESD Ratings	4	10 Layout	17
6.3 Recommended Operating Conditions	4	10.1 Layout Guidelines.....	17
6.4 Thermal Information	4	10.2 Layout Example.....	17
6.5 Electrical Characteristics	5	11 Device and Documentation Support	18
6.6 Switching Characteristics	7	11.1 Documentation Support.....	18
6.7 Timing Diagrams	7	11.2 接收文档更新通知.....	18
6.8 Typical Characteristics.....	8	11.3 Trademarks.....	18
7 Detailed Description	10	11.4 Electrostatic Discharge Caution.....	18
7.1 Overview.....	10	11.5 Glossary.....	18
7.2 Functional Block Diagram.....	10	12 Mechanical, Packaging, and Orderable Information	18
7.3 Feature Description.....	10		

4 Revision History

Changes from Revision * (January 2021) to Revision A (May 2021)	Page
• 将状态从“预告信息”更改为“量产数据”	1

5 Pin Configuration and Functions



图 5-1. DRL Package 8-Pin SOT Top View

表 5-1. Pin Functions

PIN		I/O	DESCRIPTION
NAME	NO.		
GND	1	-	Device ground.
VOUT	2, 7	O	Output power.
VIN1	3	I	Channel 1 input power.
PR1	4	I	Selects between VIN1 and VIN2. When PR1 is high VIN1 is selected, and when PR1 is low VIN2 is selected.
MODE	5	I	Device is put into Priority mode when MODE is tied to VIN1 and manual mode when MODE is pulled up to an external voltage.
VIN2	6	I	Channel 2 input power.
ST	8	O	Open drain status pin. Pulled low when VIN1 is not being used.

6 Specifications

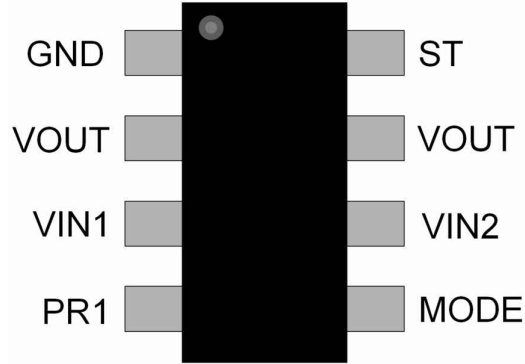
6.1 Absolute Maximum Ratings

over operating free-air temperature range (unless otherwise noted)⁽¹⁾

		MIN	MAX	UNIT
V_{IN1}, V_{IN2}	Input Voltage	- 0.3	6	V
V_{OUT}	Output Voltage	- 0.3	6	V
$V_{ST}, V_{PR1}, V_{MODE}$	Control Pin Voltage	- 0.3	6	V
I_{MAX}	Maximum Current		2.5	A
$I_{MAX,PLS}$	Maximum Pulsed Current Max duration 1ms, Duty cycle of 2%		4	A
T_J	Junction temperature		Internally Limited	°C
T_{stg}	Storage temperature	- 65	150	°C

- (1) Stresses beyond those listed under *Absolute Maximum Rating* may cause permanent damage to the device. These are stress ratings only, which do not imply functional operation of the device at these or any other conditions beyond those indicated under *Recommended Operating Condition*. Exposure to absolute-maximum-rated conditions for extended periods may affect device reliability.

6.2 ESD Ratings

			VALUE	UNIT
$V_{(ESD)}$	Electrostatic discharge	Human body model (HBM), per ANSI/ESDA/ JEDEC JS-001, all pins ⁽¹⁾	±2000	V
		Charged device model (CDM), per JEDEC specification JESD22-C101, all pins ⁽²⁾	±500	

- (1) JEDEC document JEP155 states that 500-V HBM allows safe manufacturing with a standard ESD control process.
 (2) JEDEC document JEP157 states that 250-V CDM allows safe manufacturing with a standard ESD control process.

6.3 Recommended Operating Conditions

over operating free-air temperature range (unless otherwise noted)

		MIN	NOM	MAX	UNIT
V_{IN1}, V_{IN2}	Input Voltage	1.6		5.5	V
V_{OUT}	Output Voltage	0		5.5	V
$V_{ST}, V_{MODE}, V_{PR1}$	Control Pin Voltage	0		5.5	V
T_A	Ambient Temperature	- 40		105	°C

6.4 Thermal Information

THERMAL METRIC ⁽¹⁾		TPS2116		UNIT
		DRL (SOT)		
		8-PINS		
$R_{\theta JA}$	Junction-to-ambient thermal resistance	111.5		°C/W
$R_{\theta JC(top)}$	Junction-to-case (top) thermal resistance	19.4		°C/W
$R_{\theta JB}$	Junction-to-board thermal resistance	35.8		°C/W
Ψ_{JT}	Junction-to-top characterization parameter	1.2		°C/W
Ψ_{JB}	Junction-to-board characterization parameter	19.1		°C/W

6.4 Thermal Information (continued)

THERMAL METRIC ⁽¹⁾		TPS2116	
		DRL (SOT)	
		8-PINS	
			UNIT
$R_{\theta JC(bot)}$	Junction-to-case (bottom) thermal resistance	N/A	°C/W

(1) For more information about traditional and new thermal metrics, see the [Semiconductor and IC Package Thermal Metrics](#) application report.

6.5 Electrical Characteristics

Over operating free-air temperature range and operating voltage range of 1.6V to 5.5V (unless otherwise noted). Typical specifications are at an input voltage of 3.3V and ambient temperature of 25°C.

PARAMETER		TEST CONDITIONS	T _A	MIN	TYP	MAX	UNIT
Power Consumption							
$I_{STBY, VIN1}$	VIN1 Standby Current	VIN2 powers VOUT VIN1 > VIN2 + 0.1V	25°C		1.1		µA
			-40°C to 85°C			1.9	µA
			-40°C to 105°C			2	µA
		VIN2 powers VOUT VIN2 > VIN1 + 0.2V	25°C		0.22		µA
			-40°C to 85°C			0.31	µA
			-40°C to 105°C			0.32	µA
$I_{STBY, VIN2}$	VIN2 Standby Current	VIN1 powers VOUT VIN2 > VIN1 + 0.2V	25°C		1.2		µA
			-40°C to 85°C			2	µA
			-40°C to 105°C			2.1	µA
		VIN1 powers VOUT VIN1 > VIN2 + 0.1V	25°C		0.05		µA
			-40°C to 85°C			0.07	µA
			-40°C to 105°C			0.09	µA
$I_{Q, VIN1}$	VIN1 Quiescent Current	VIN1 powers VOUT VIN1 > VIN2 + 0.1V	25°C		1.32		µA
			-40°C to 85°C			3.6	µA
			-40°C to 105°C			4.4	µA
		VIN1 powers VOUT VIN2 > VIN1 + 0.2V	25°C		0.3		µA
			-40°C to 85°C			0.51	µA
			-40°C to 105°C			0.55	µA
$I_{Q, VIN2}$	VIN2 Quiescent Current	VIN2 powers VOUT VIN2 > VIN1 + 0.2V	25°C		1.35		µA
			-40°C to 85°C			3.7	µA
			-40°C to 105°C			4.5	µA
		VIN2 powers VOUT VIN1 > VIN2 + 0.1V	25°C		0.1		µA
			-40°C to 85°C			0.27	µA
			-40°C to 105°C			0.29	µA
$I_{SD, VIN1}$	VIN1 Shutdown Current	MODE = 0V, PR1 = 5V VIN1 > VIN2 VOUT = 0V	25°C		0.1		µA
			-40°C to 85°C			1.3	µA
			-40°C to 105°C			2.9	µA
		MODE = 0V, PR1 = 5V VIN1 < VIN2 VOUT = 0V	25°C		0.05		µA
			-40°C to 85°C			1	µA
			-40°C to 105°C			2.4	µA

6.5 Electrical Characteristics (continued)

Over operating free-air temperature range and operating voltage range of 1.6V to 5.5V (unless otherwise noted). Typical specifications are at an input voltage of 3.3V and ambient temperature of 25°C.

PARAMETER		TEST CONDITIONS	T _A	MIN	TYP	MAX	UNIT	
I _{SD,VIN2}	VIN2 Shutdown Current	MODE = 0V, PR1 = 5V VIN2 > VIN1 VOUT = 0V	25°C		0.05		µA	
			-40°C to 85°C			1.3	µA	
			-40°C to 105°C			2.9	µA	
		MODE = 0V, PR1 = 5V VIN2 < VIN1 VOUT = 0V	25°C		0.05			µA
			-40°C to 85°C			0.7		µA
			-40°C to 105°C			2.1		µA
I _{REV}	Reverse leakage current out of VIN _x	V _{OUT} = 5.5V V _{INx} = 0V, V _{INy} = Open	25°C		0.001		µA	
			85°C		0.05		µA	
			105°C		0.15		µA	
	Reverse leakage current into VOUT	V _{OUT} = 5.5V V _{INx} = 0V, V _{INy} = Open	25°C		0.01		µA	
			85°C		0.1		µA	
			105°C		0.25		µA	
I _{PR1}	PR1 pin leakage		-40°C to 105°C			0.1	µA	
I _{MODE}	MODE pin leakage		-40°C to 105°C			0.1	µA	
I _{ST}	ST pin leakage		-40°C to 105°C			0.03	µA	
Performance								
R _{ON}	On-Resistance	VIN _x = 5V I _{OUT} = 200mA	25°C		37	46	m Ω	
			-40°C to 85°C			55	m Ω	
			-40°C to 105°C			60	m Ω	
		VIN _x = 3.3V I _{OUT} = 200mA	25°C		40	48	m Ω	
			-40°C to 85°C			55	m Ω	
			-40°C to 105°C			59	m Ω	
		VIN _x = 1.8V I _{OUT} = 200mA	25°C		41	51	m Ω	
			-40°C to 85°C			61	m Ω	
			-40°C to 105°C			66	m Ω	
		VIN _x = 1.6V I _{OUT} = 200mA	25°C		42	52	m Ω	
			-40°C to 85°C			68	m Ω	
			-40°C to 105°C			74	m Ω	
V _{OL,ST}	Status pin V _{OL}	I _{ST} = 1mA	-40°C to 105°C			0.1	V	
t _{ST}	Status pin response time	ST pin pulled high to low R _{ST} = 10k Ω	-40°C to 105°C		5		µs	
V _{REF}	PR1 reference voltage		-40°C to 105°C	0.92	1	1.08	V	
V _{IH,MODE}	MODE logic high threshold		-40°C to 105°C	1		5.5	V	
V _{IL,MODE}	MODE logic low threshold		-40°C to 105°C	0		0.35	V	
Protection								
t _{RCB}	Reverse current blocking response time	V _{OUT} > Selected VIN + 1V	-40°C to 105°C		2		µs	
V _{RCB,R}	Reverse current blocking rising threshold (V _{OUT} - V _{IN})		-40°C to 105°C		42	70	mV	
V _{RCB,F}	Reverse current blocking falling threshold (V _{OUT} - V _{IN})		-40°C to 105°C		17	40	mV	
I _{RCB}	Reverse current blocking activation current		-40°C to 105°C		1.4	4	A	

6.5 Electrical Characteristics (continued)

Over operating free-air temperature range and operating voltage range of 1.6V to 5.5V (unless otherwise noted). Typical specifications are at an input voltage of 3.3V and ambient temperature of 25°C.

PARAMETER		TEST CONDITIONS	T _A	MIN	TYP	MAX	UNIT
TSD	Thermal shutdown		-		170		°C
TSD _{HYS}	Thermal shutdown hysteresis		-		20		°C

6.6 Switching Characteristics

Typical switching characteristics are defined at an ambient temperature of 25°C

PARAMETER		TEST CONDITIONS	MIN	TYP	MAX	UNIT
Switchover						
t _{sw}	Switchover time, VINx = 5 V	R _L = 10 Ω, C _L = 10 uF		8		us
t _{sw}	Switchover time, VINx = 3.3 V	R _L = 10 Ω, C _L = 10 uF		6.2		us
t _{sw}	Switchover time, VINx = 1.8 V	R _L = 10 Ω, C _L = 10 uF		17.7		us
t _D	Delay time, VINx = 5 V	R _L = 100 Ω, C _L = 10 uF		1		ms
t _D	Delay time, VINx = 3.3 V	R _L = 100 Ω, C _L = 10 uF		1.2		ms
t _D	Delay time, VINx = 1.8 V	R _L = 100 Ω, C _L = 10 uF		1.4		ms
t _{ss}	Soft-start time, VINx = 5 V	R _L = 100 Ω, C _L = 10 uF		1.7		ms
t _{ss}	Soft-start time, VINx = 3.3 V	R _L = 100 Ω, C _L = 10 uF		1.3		ms
t _{ss}	Soft-start time, VINx = 1.8 V	R _L = 100 Ω, C _L = 10 uF		0.9		ms

6.7 Timing Diagrams



图 6-1. TPS2116 Timing Diagram

6.8 Typical Characteristics

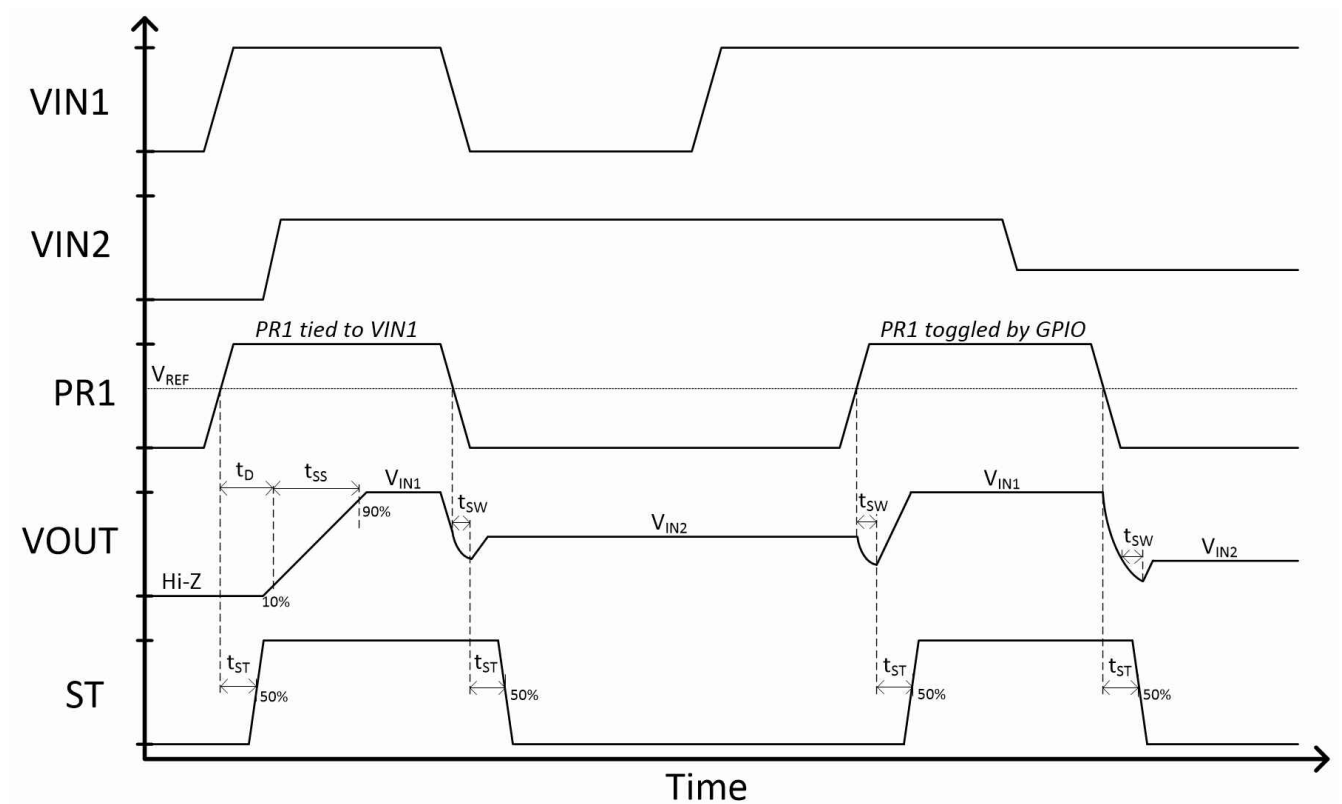
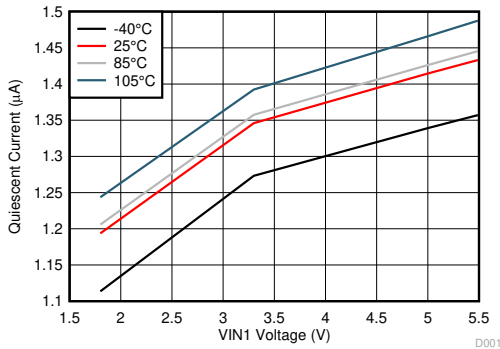

VIN2 = 1.6 V VOUT = Open

图 6-2. VIN1 Quiescent Current vs Input Voltage

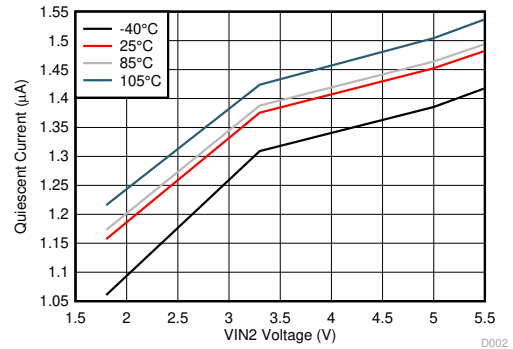

VIN1 = 1.6 V VOUT = Open

图 6-3. VIN2 Quiescent Current vs Input Voltage

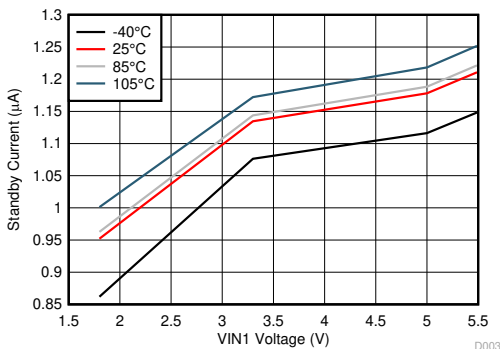

VIN2 = 1.6 V VOUT = Open

图 6-4. VIN1 Standby Current vs Input Voltage

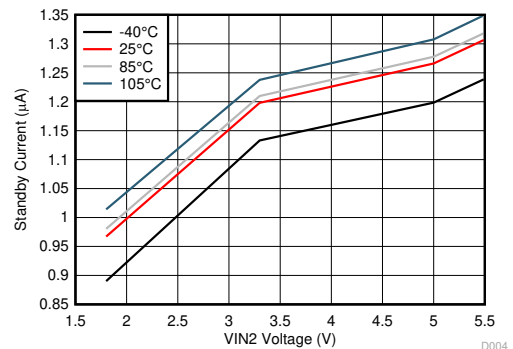

VIN1 = 1.6 V VOUT = Open

图 6-5. VIN2 Standby Current vs Input Voltage

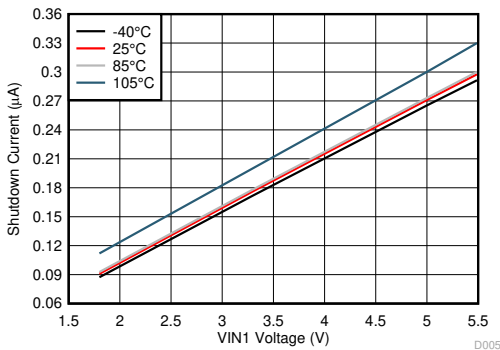

VIN2 = 1.6 V VOUT = Open

图 6-6. VIN1 Shutdown Current vs Input Voltage

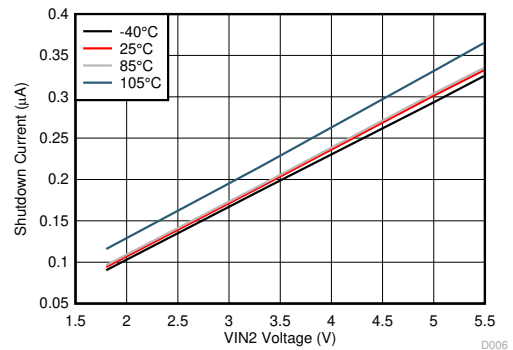

VIN1 = 1.6 V VOUT = 0 V

图 6-7. VIN2 Shutdown Current vs Input Voltage

6.8 Typical Characteristics (continued)

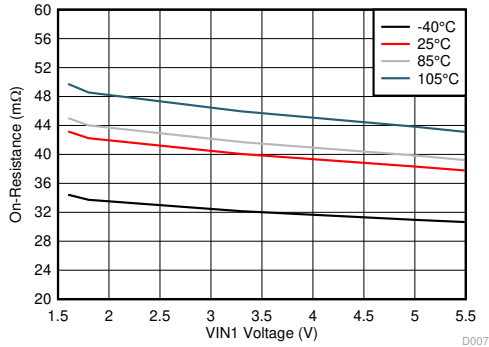

$I_{OUT} = 200 \text{ mA}$

图 6-8. Channel 1 On-Resistance vs Input Voltage

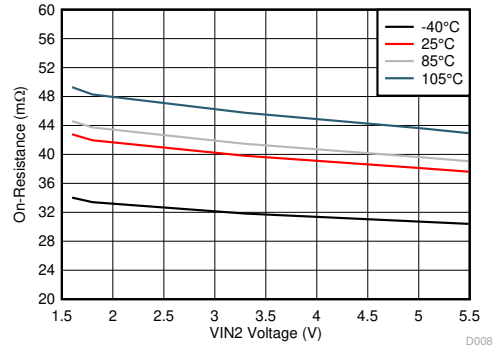

$I_{OUT} = 200 \text{ mA}$

图 6-9. Channel 2 On-Resistance vs Input Voltage

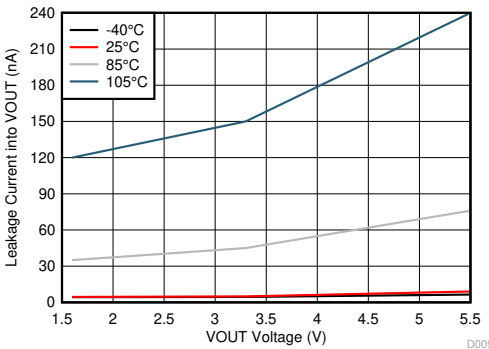

$V_{INx} = 0 \text{ V}$ $V_{INy} = \text{Open}$

图 6-10. Reverse Leakage Current into VOUT

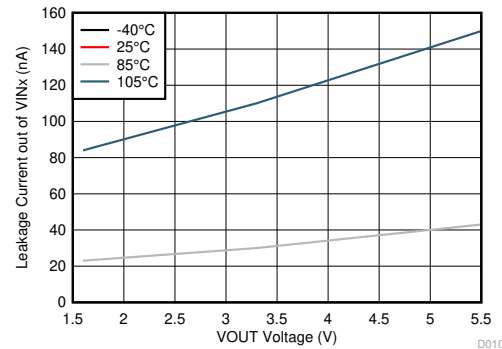

$V_{INx} = 0 \text{ V}$ $V_{INy} = \text{Open}$

图 6-11. Reverse Leakage Current out of VINx



图 6-12. Output Voltage Drop vs Output Capacitance (MODE = 5 V, $R_L = 10 \Omega$)



图 6-13. Manual Mode Switchover Behavior (MODE = 5 V, $R_L = 10 \Omega$, $C_L = 10 \mu\text{F}$)

7 Detailed Description

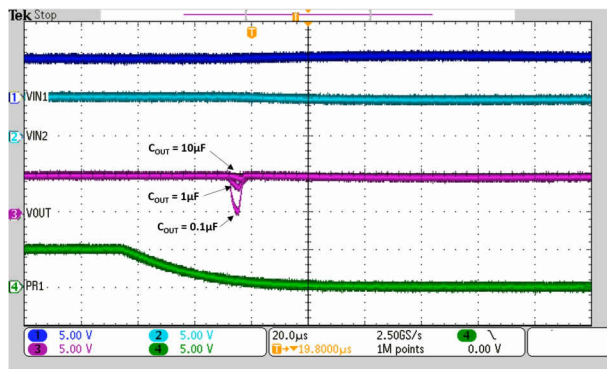
7.1 Overview

The TPS2116 is a power mux device with a voltage rating of 1.6 V to 5.5 V and a maximum current rating of 2.5 A. The device uses N-channel MOSFETs to switch between supplies while providing a controlled slew rate when voltage is first applied.

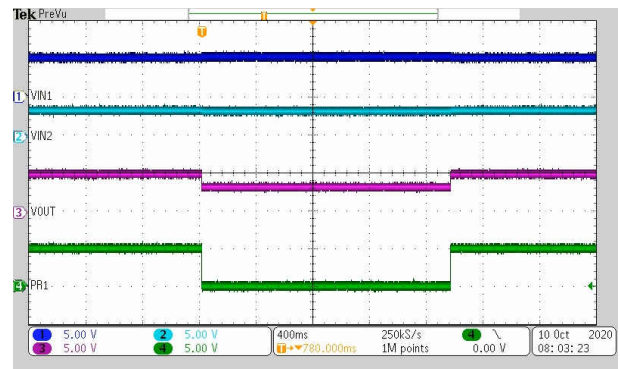
The TPS2116 can be configured for two different switchover behaviors depending on the application. Automatic priority mode prioritizes the supply connected to VIN1 and switches over to the secondary supply (VIN2) when VIN1 drops. Manual mode allows the user to toggle a GPIO or enable signal to switch between channels.

Due to its low quiescent of 1.32 μ A (typical) and standby current of 50 nA (typical), the TPS2116 is ideal for systems where a battery is connected to one of the inputs. These low currents extend the life and operation of the battery when in use.

7.2 Functional Block Diagram

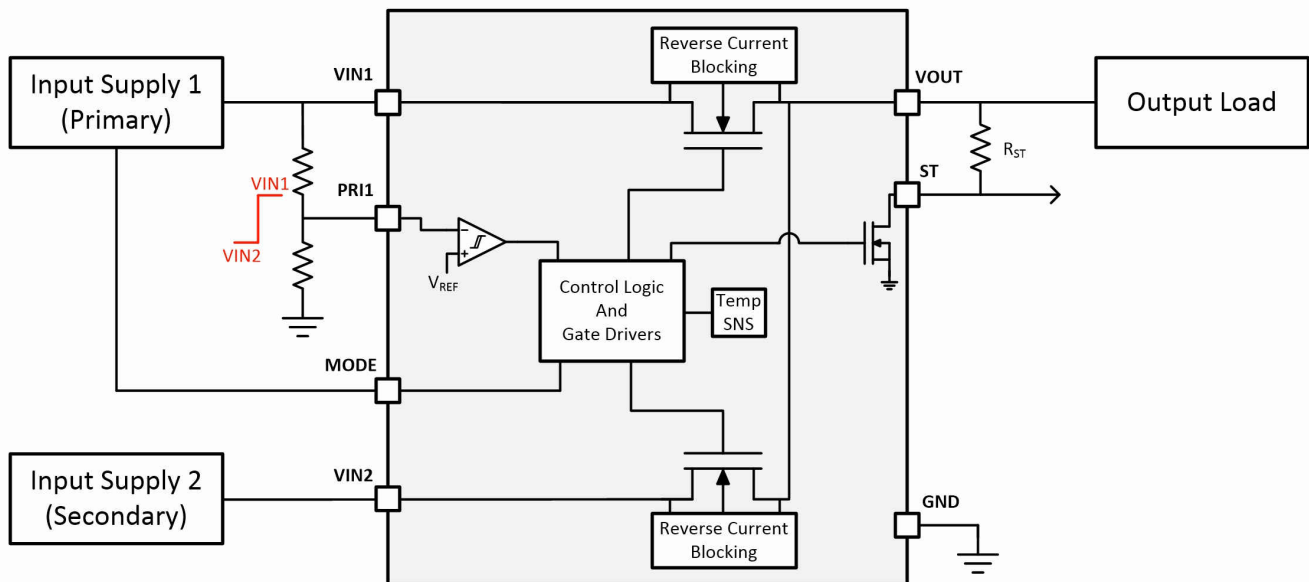

7.3 Feature Description

The below sections detail the features of the TPS2116.

7.3.1 Truth Table

The below table shows the expected behavior of the TPS2116. For Priority mode, VIN1 is connected to PR1 through a resistor divider.

MODE	VIN1	VIN2	PR1	ST	VOUT
VIN1 (Priority mode)	High ($V_{PR1} > V_{REF}$)	X	VIN1 through resistor divider	High	VIN1
	Low ($V_{PR1} < V_{REF}$)	≥ 1.6 V		Low	VIN2
External Bias ≥ 1 V (Manual mode)	≥ 1.6 V	X	High	High	VIN1
	X	≥ 1.6 V	Low	Low	VIN2
External Bias ≤ 0.35 V (Manual mode)	X	X	High	Low	Hi-Z
	$> V_{IN2}$	X	Low	High	VIN1
	X	$> V_{IN1}$	Low	Low	VIN2

X = do not care

7.3.2 Soft Start

When an input voltage is applied to the TPS2116 and the output voltage is lower than 1 V, the output will be brought up with soft start to minimize the inrush current due to output capacitance. However, when the device switches from one power supply to another (switchover) and $V_{OUT} > 1$ V, soft start is not used to minimize the output voltage drop. For linear soft start behavior, it is recommended to have an output capacitance of at least 0.1 μ F.

7.3.3 Status Indication

The ST pin is an open drain output that should be pulled up to an external voltage for proper operation. When the TPS2116 is powering the output using VIN1, the ST pin will be pulled high by the external voltage source. Even if the device is blocking reverse current from VOUT to VIN1, selection of VIN1 will keep the ST pin pulled high. When the TPS2116 is powering the output using VIN2 or both channels are disabled, the ST pin will be pulled low. During thermal shutdown, the ST pin will be pulled low regardless of the channel being used.

7.3.4 Reverse Current Blocking

The TPS2116 initiates reverse current blocking (RCB) when the VOUT voltage is externally biased and exceeds the input voltage supply being used. Once the output voltage is higher than the input voltage by 42mV ($V_{RCB,R}$), the device will shut off. During this state, the leakage into VOUT and out of VIN is defined by I_{REV} . Once the voltage difference between the output and input lowers to 17mV ($V_{RCB,F}$), the channel will turn back on.



图 7-1. Reverse Current Blocking Behavior

If RCB is expected to occur, it is recommended to clamp the output or use a high output capacitance (about 100 μ F). This will prevent voltage spikes from damaging the device due to output inductance.

7.4 VINx Collapse Rate

The TPS2116 uses the highest voltage supply to power the device. When one supply drops below the other, the device changes the supply used to power the device. If the supply powering the device drops at a rate faster than 1 V/10 μ s, the other supply must be at 2.5 V or higher to prevent the device from resetting. If the other supply is lower than 2.5 V, then the device may not be able to switch to the supply quickly enough, and the device will reset and turn on with soft start timing if $V_{OUT} < 1$ V.

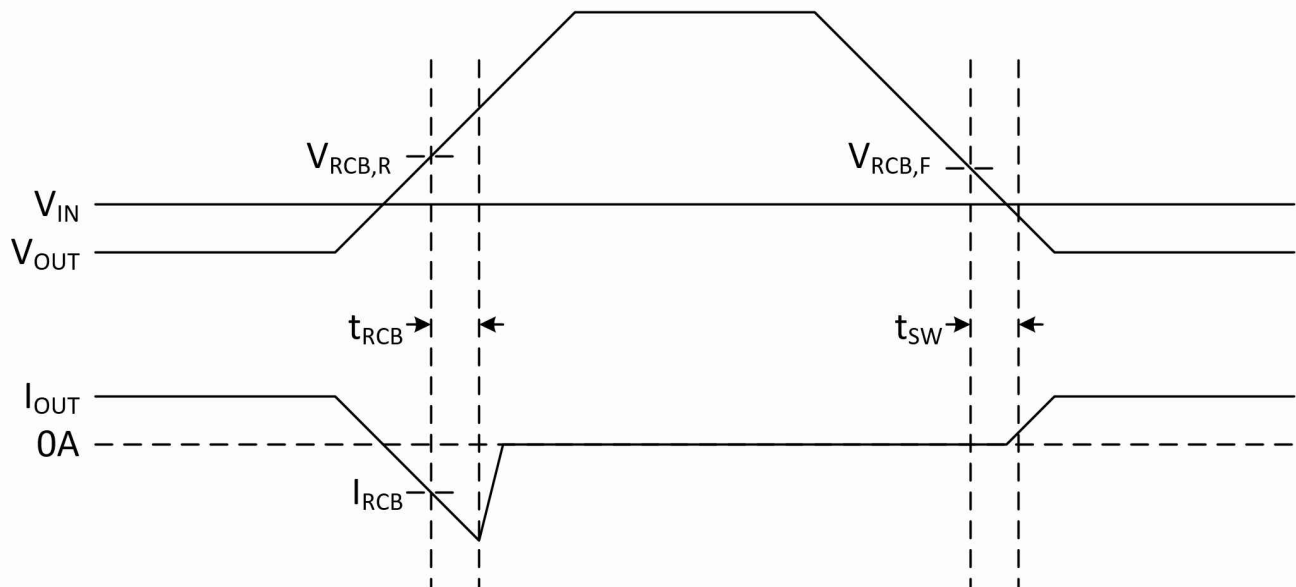
7.5 Output Voltage Drop

The output voltage drop during switchover from one supply to another is based on the load capacitance and load resistance. The stronger the resistive load, the faster the output will discharge. The higher the capacitance on the output, the less the voltage will drop during switchover.

7.6 Device Functional Modes

The below sections detail the two different configuration options for the device.

7.6.1 Priority/Manual Mode

When MODE is tied high, PR1 determines the channel selected. To configure VIN1 as the priority supply, connect MODE to VIN1 and set the proper threshold through a resistor divider from VIN1 to PR1. To configure manual selection, pull up MODE to an external supply and follow the truth table. When PR1 is pulled above V_{REF} , the voltage on VIN1 is used to power the output, and when it is pulled below V_{REF} , VIN2 is used to power the output. The expected behavior for the device is shown in the waveform below.



图 7-2. Priority/Manual Mode Switching

When PR1 is toggled, the device implements a break-before-make switchover which shuts off both channels before turning on the new channel to power the output. This means that for time t_{SW} , the output is unpowered and will dip depending on the load current and output capacitance. If the output voltage is greater than the input supply being switched to, then the device will not turn on the new channel until the output has discharged down to $V_{IN} + V_{RCB}$ to prevent reverse current flow.

When MODE is pulled low and PR1 is pulled high, the device enters shutdown. Both channels are turned off and the output is high impedance. When the PR1 pin is pulled low, the higher voltage supply between VIN1 and VIN2 is passed to the output.

7.6.1.1 Priority Switching

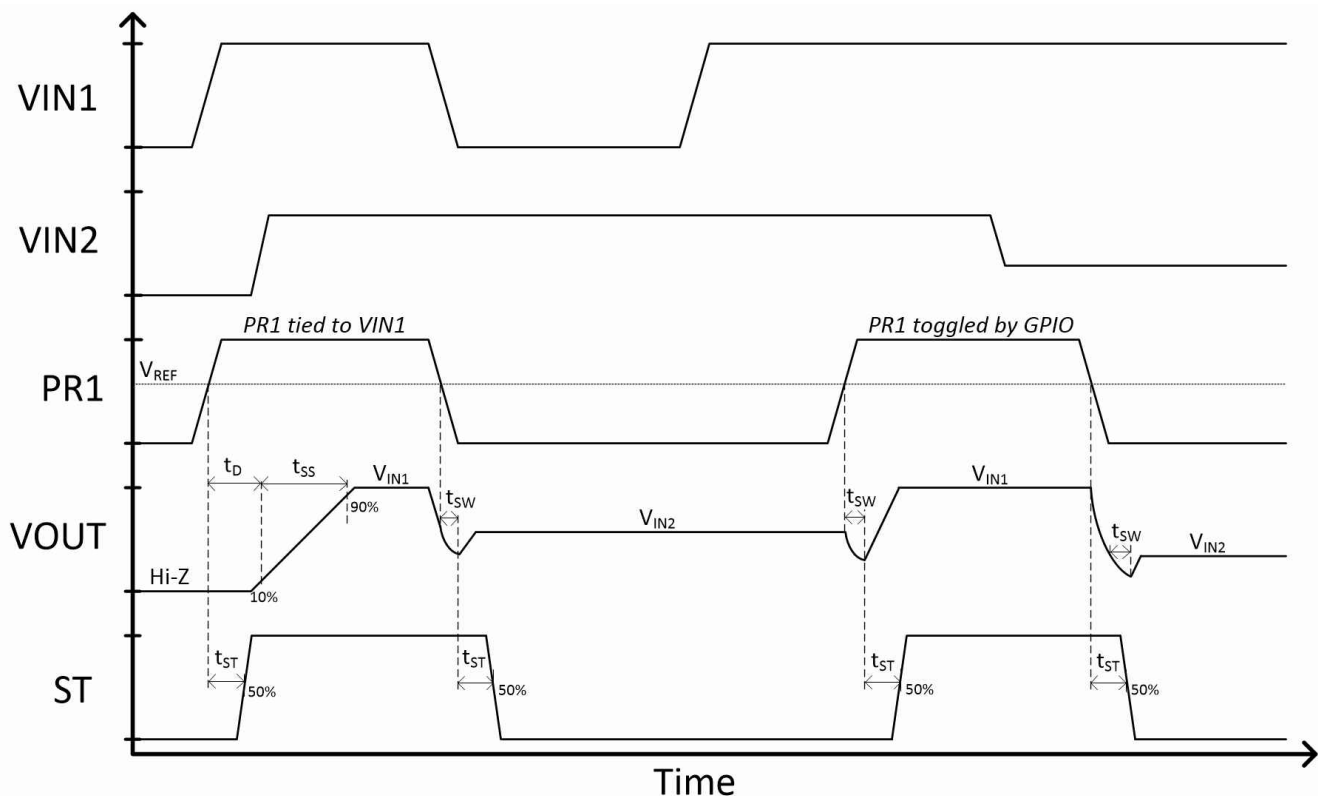
In the case where VIN1 takes priority over VIN2, a resistor divider can be used to set the switchover voltage threshold. When VIN1 is first applied, PR1 is brought high and VOUT is powered by that input. As VIN1 begins to drop, the voltage on PR1 is lowered until it crosses the V_{REF} threshold. At this point, the device switches over to VIN2.

7.6.1.2 Manual Switching

For applications where a GPIO pin is used to select which input passes to the output, the GPIO pin can be directly connected to the PR1 pin when MODE is tied high ($\geq 1V$). When the GPIO is pulled high, VIN1 is used, and when the GPIO pin is pulled low, VIN2 is used.

Manual mode can also disable both channels by pulling the MODE pin low and keeping PR1 high. In this state, the output of the device is high impedance and the leakage on each input is the shutdown current, $I_{SD,VINx}$.

8 Application and Implementation

Note

Information in the following applications sections is not part of the TI component specification, and TI does not warrant its accuracy or completeness. TI's customers are responsible for determining suitability of components for their purposes, as well as validating and testing their design implementation to confirm system functionality.

8.1 Application Information

This section highlights some of the design considerations when implementing this device in various applications.

8.2 Typical Application

This typical application demonstrates how the TPS2116 device can be used to control inrush current for high output capacitances.



图 8-1. TPS2116 Typical Application Diagram

8.2.1 Design Requirements

For this example, the values below are used as the design parameters.

表 8-1. Design Parameters

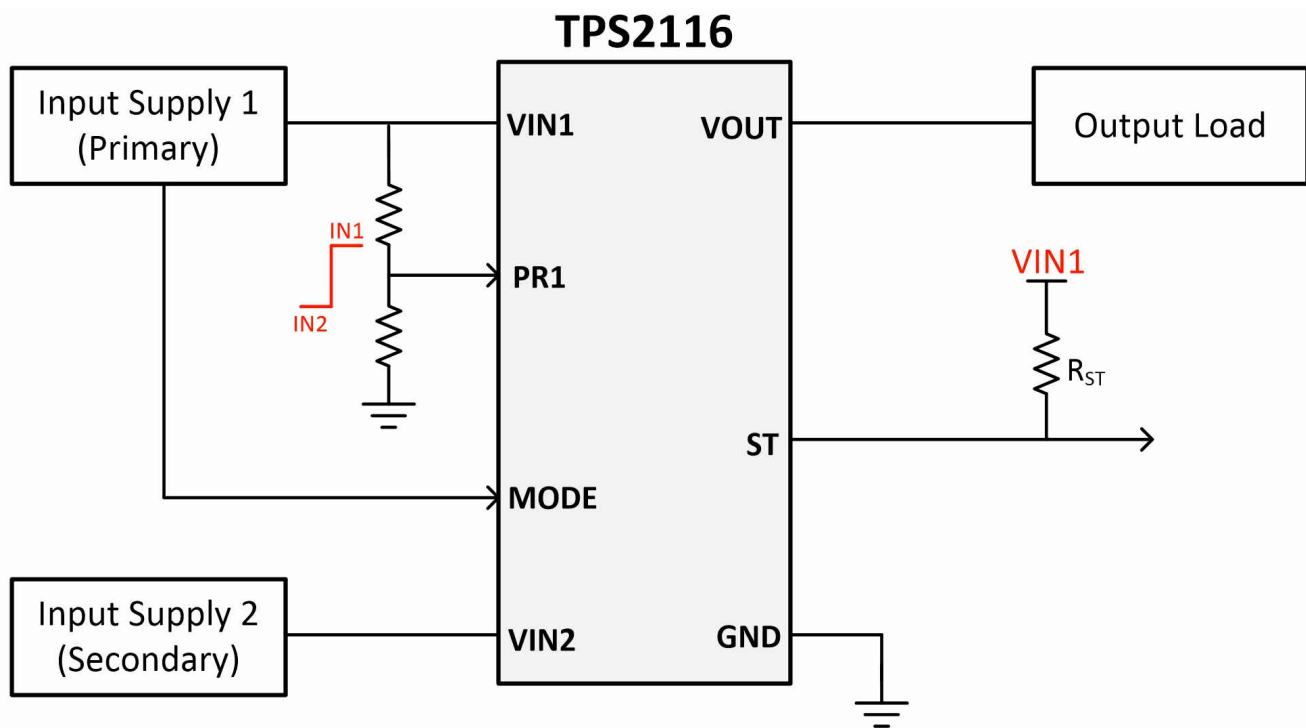
PARAMETER	VALUE
VIN1 Input Voltage	5 V
Mode	Priority
Output Capacitance	100 μ F
Maximum Inrush Current	500 mA

8.2.2 Detailed Design Procedure

To determine how much inrush current is caused by the output capacitor, use the equation below.

$$I_{\text{INRUSH}} = C_{\text{OUT}} \times V_{\text{OUT}} / t_{\text{SS}} \quad (1)$$

where

- I_{INRUSH} = amount of inrush current caused by C_{OUT}
- C_{OUT} = capacitance on V_{OUT}
- t_{SS} = output voltage soft start time
- V_{OUT} = final value of the output voltage

With a final output voltage of 5 V, the expected rise time is 1.7 ms. Using the inrush current equation, the inrush current caused by a 100- μF capacitance would be 294 mA, well below the 500-mA target.

8.2.3 Application Curves

The below oscilloscope capture shows 5 V being applied to V_{IN1} . The output comes up with slew rate control and limits the inrush current to below 500 mA.



图 8-2. TPS2116 Inrush Current Control

9 Power Supply Recommendations

The device is designed to operate with a VIN range of 1.6 V to 5.5 V. The VIN power supplies must be well regulated and placed as close to the device terminals as possible. The power supplies must be able to withstand all transient load current steps. In most situations, using an input capacitance (C_{IN}) of 1 μ F is sufficient to prevent the supply voltage from dipping when the switch is turned on. In cases where the power supply is slow to respond to a large transient current or large load current step, additional bulk capacitance may be required on the input.

10 Layout

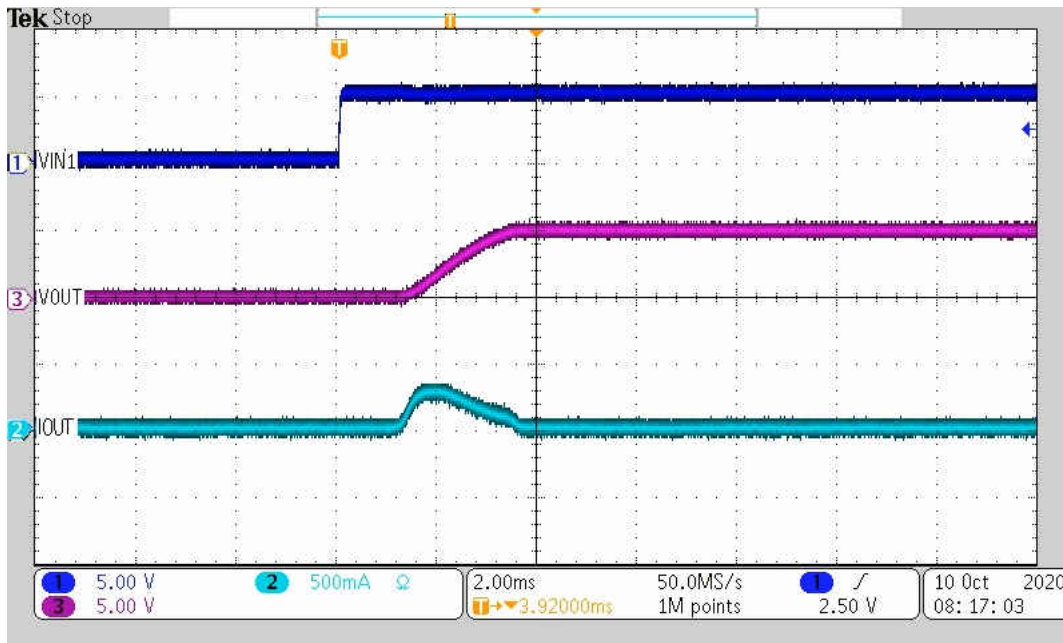
10.1 Layout Guidelines

For best performance, all traces must be as short as possible. To be most effective, the input and output capacitors must be placed close to the device to minimize the effects that parasitic trace inductances may have on normal operation. Using wide traces for VIN1, VIN2, VOUT, and GND helps minimize the parasitic electrical effects.

10.2 Layout Example



图 10-1. TPS2116 Layout Example

11 Device and Documentation Support

11.1 Documentation Support

11.1.1 Related Documentation

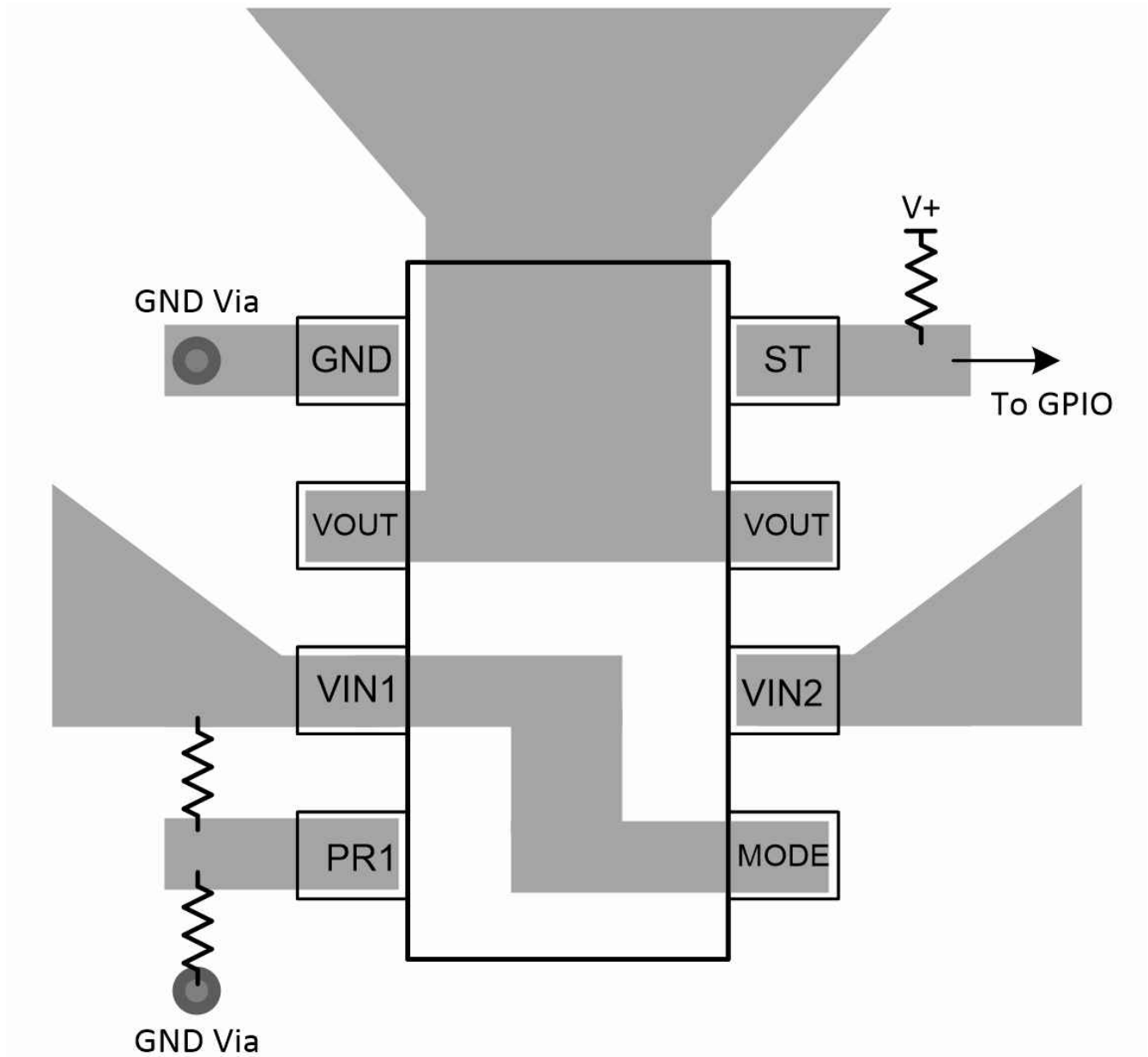
For related documentation see the following:

- [Basics of Power MUX](#)
- [11 Ways to Protect Your Power Path](#)

11.2 接收文档更新通知

要接收文档更新通知，请导航至 [ti.com](https://www.ti.com) 上的器件产品文件夹。点击 [订阅更新](#) 进行注册，即可每周接收产品信息更改摘要。有关更改的详细信息，请查看任何已修订文档中包含的修订历史记录。

11.3 Trademarks

所有商标均为其各自所有者的财产。

11.4 Electrostatic Discharge Caution



This integrated circuit can be damaged by ESD. Texas Instruments recommends that all integrated circuits be handled with appropriate precautions. Failure to observe proper handling and installation procedures can cause damage.

ESD damage can range from subtle performance degradation to complete device failure. Precision integrated circuits may be more susceptible to damage because very small parametric changes could cause the device not to meet its published specifications.

11.5 Glossary

[TI Glossary](#) This glossary lists and explains terms, acronyms, and definitions.

12 Mechanical, Packaging, and Orderable Information

The following pages include mechanical, packaging, and orderable information. This information is the most current data available for the designated devices. This data is subject to change without notice and revision of this document. For browser-based versions of this data sheet, refer to the left-hand navigation.

重要声明和免责声明

TI 提供技术和可靠性数据 (包括数据表)、设计资源 (包括参考设计)、应用或其他设计建议、网络工具、安全信息和其他资源, 不保证没有瑕疵且不做任何明示或暗示的担保, 包括但不限于对适销性、某特定用途方面的适用性或不侵犯任何第三方知识产权的暗示担保。

这些资源可供使用 TI 产品进行设计的熟练开发人员使用。您将自行承担以下全部责任: (1) 针对您的应用选择合适的 TI 产品, (2) 设计、验证并测试您的应用, (3) 确保您的应用满足相应标准以及任何其他安全、安保或其他要求。这些资源如有变更, 恕不另行通知。TI 授权您仅可将这些资源用于研发本资源所述的 TI 产品的应用。严禁对这些资源进行其他复制或展示。您无权使用任何其他 TI 知识产权或任何第三方知识产权。您应全额赔偿因在这些资源的使用中对 TI 及其代表造成的任何索赔、损害、成本、损失和债务, TI 对此概不负责。

TI 提供的产品受 TI 的销售条款 (<https://www.ti.com/legal/termsofsale.html>) 或 [ti.com](https://www.ti.com) 上其他适用条款/TI 产品随附的其他适用条款的约束。TI 提供这些资源并不会扩展或以其他方式更改 TI 针对 TI 产品发布的适用的担保或担保免责声明。

邮寄地址: Texas Instruments, Post Office Box 655303, Dallas, Texas 75265

Copyright © 2021, 德州仪器 (TI) 公司

PACKAGING INFORMATION

Orderable Device	Status (1)	Package Type	Package Drawing	Pins	Package Qty	Eco Plan (2)	Lead finish/ Ball material (6)	MSL Peak Temp (3)	Op Temp (°C)	Device Marking (4/5)	Samples
TPS2116DRLR	ACTIVE	SOT-5X3	DRL	8	4000	RoHS & Green	Call TI SN	Level-1-260C-UNLIM	-40 to 125	2116	Samples

(1) The marketing status values are defined as follows:

ACTIVE: Product device recommended for new designs.

LIFEBUY: TI has announced that the device will be discontinued, and a lifetime-buy period is in effect.

NRND: Not recommended for new designs. Device is in production to support existing customers, but TI does not recommend using this part in a new design.

PREVIEW: Device has been announced but is not in production. Samples may or may not be available.

OBSOLETE: TI has discontinued the production of the device.

(2) **RoHS:** TI defines "RoHS" to mean semiconductor products that are compliant with the current EU RoHS requirements for all 10 RoHS substances, including the requirement that RoHS substance do not exceed 0.1% by weight in homogeneous materials. Where designed to be soldered at high temperatures, "RoHS" products are suitable for use in specified lead-free processes. TI may reference these types of products as "Pb-Free".

RoHS Exempt: TI defines "RoHS Exempt" to mean products that contain lead but are compliant with EU RoHS pursuant to a specific EU RoHS exemption.

Green: TI defines "Green" to mean the content of Chlorine (Cl) and Bromine (Br) based flame retardants meet JS709B low halogen requirements of <=1000ppm threshold. Antimony trioxide based flame retardants must also meet the <=1000ppm threshold requirement.

(3) MSL, Peak Temp. - The Moisture Sensitivity Level rating according to the JEDEC industry standard classifications, and peak solder temperature.

(4) There may be additional marking, which relates to the logo, the lot trace code information, or the environmental category on the device.

(5) Multiple Device Markings will be inside parentheses. Only one Device Marking contained in parentheses and separated by a "-" will appear on a device. If a line is indented then it is a continuation of the previous line and the two combined represent the entire Device Marking for that device.

(6) Lead finish/Ball material - Orderable Devices may have multiple material finish options. Finish options are separated by a vertical ruled line. Lead finish/Ball material values may wrap to two lines if the finish value exceeds the maximum column width.

Important Information and Disclaimer:The information provided on this page represents TI's knowledge and belief as of the date that it is provided. TI bases its knowledge and belief on information provided by third parties, and makes no representation or warranty as to the accuracy of such information. Efforts are underway to better integrate information from third parties. TI has taken and continues to take reasonable steps to provide representative and accurate information but may not have conducted destructive testing or chemical analysis on incoming materials and chemicals. TI and TI suppliers consider certain information to be proprietary, and thus CAS numbers and other limited information may not be available for release.

In no event shall TI's liability arising out of such information exceed the total purchase price of the TI part(s) at issue in this document sold by TI to Customer on an annual basis.

TAPE AND REEL INFORMATION

QUADRANT ASSIGNMENTS FOR PIN 1 ORIENTATION IN TAPE

*All dimensions are nominal

Device	Package Type	Package Drawing	Pins	SPQ	Reel Diameter (mm)	Reel Width W1 (mm)	A0 (mm)	B0 (mm)	K0 (mm)	P1 (mm)	W (mm)	Pin1 Quadrant
TPS2116DRLR	SOT-5X3	DRL	8	4000	180.0	8.4	2.75	1.9	0.8	4.0	8.0	Q3

TAPE AND REEL BOX DIMENSIONS

*All dimensions are nominal

Device	Package Type	Package Drawing	Pins	SPQ	Length (mm)	Width (mm)	Height (mm)
TPS2116DRLR	SOT-5X3	DRL	8	4000	210.0	185.0	35.0

EXAMPLE BOARD LAYOUT

DRL0008A

SOT-5X3 - 0.6 mm max height

PLASTIC SMALL OUTLINE

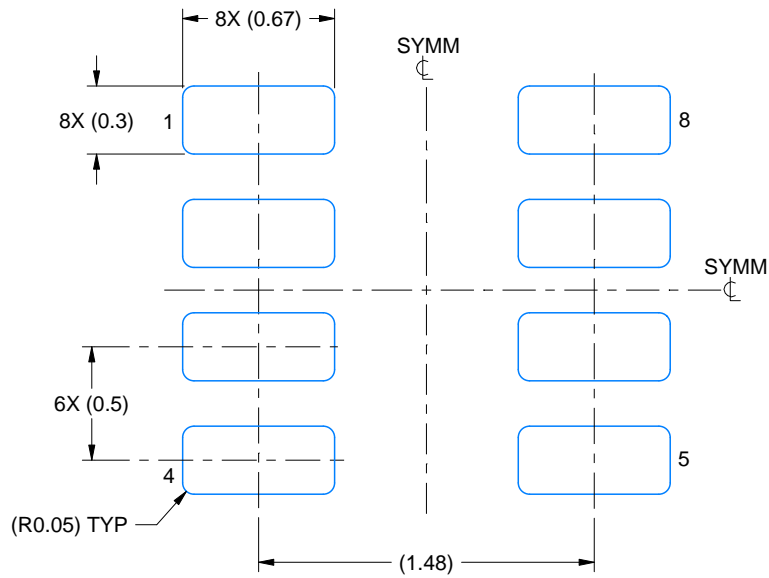

LAND PATTERN EXAMPLE
EXPOSED METAL SHOWN
SCALE:30X

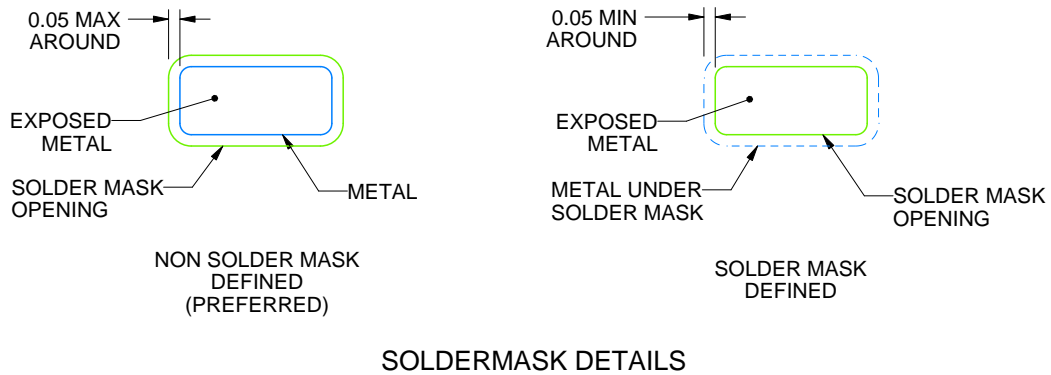

SOLDERMASK DETAILS

4224486/G 11/2024

NOTES: (continued)

5. Publication IPC-7351 may have alternate designs.
6. Solder mask tolerances between and around signal pads can vary based on board fabrication site.
7. Land pattern design aligns to IPC-610, Bottom Termination Component (BTC) solder joint inspection criteria.

EXAMPLE STENCIL DESIGN

DRL0008A

SOT-5X3 - 0.6 mm max height

PLASTIC SMALL OUTLINE

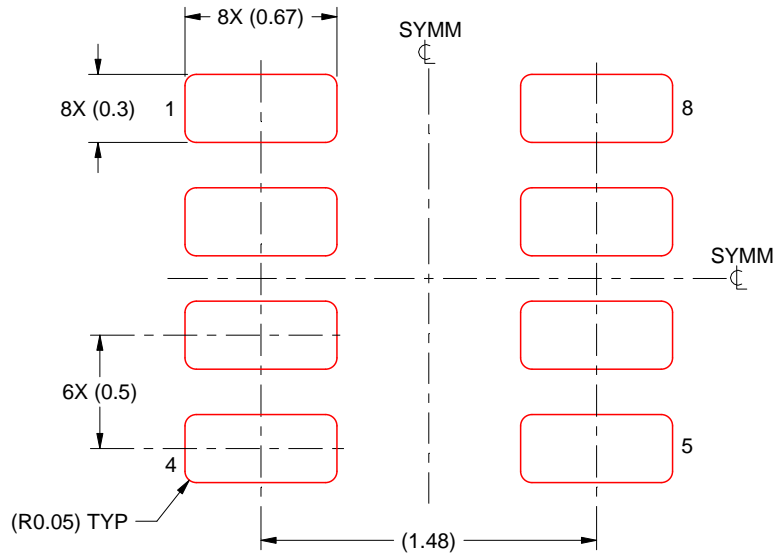

SOLDER PASTE EXAMPLE
BASED ON 0.1 mm THICK STENCIL
SCALE:30X

4224486/G 11/2024

NOTES: (continued)

8. Laser cutting apertures with trapezoidal walls and rounded corners may offer better paste release. IPC-7525 may have alternate design recommendations.
9. Board assembly site may have different recommendations for stencil design.

重要通知和免责声明

TI“按原样”提供技术和可靠性数据（包括数据表）、设计资源（包括参考设计）、应用或其他设计建议、网络工具、安全信息和其他资源，不保证没有瑕疵且不做任何明示或暗示的担保，包括但不限于对适销性、某特定用途方面的适用性或不侵犯任何第三方知识产权的暗示担保。

这些资源可供使用 TI 产品进行设计的熟练开发人员使用。您将自行承担以下全部责任：(1) 针对您的应用选择合适的 TI 产品，(2) 设计、验证并测试您的应用，(3) 确保您的应用满足相应标准以及任何其他功能安全、信息安全、监管或其他要求。

这些资源如有变更，恕不另行通知。TI 授权您仅可将这些资源用于研发本资源所述的 TI 产品的相关应用。严禁以其他方式对这些资源进行复制或展示。您无权使用任何其他 TI 知识产权或任何第三方知识产权。您应全额赔偿因在这些资源的使用中对 TI 及其代表造成的任何索赔、损害、成本、损失和债务，TI 对此概不负责。

TI 提供的产品受 [TI 的销售条款](#) 或 [ti.com](#) 上其他适用条款/TI 产品随附的其他适用条款的约束。TI 提供这些资源并不会扩展或以其他方式更改 TI 针对 TI 产品发布的适用的担保或担保免责声明。

TI 反对并拒绝您可能提出的任何其他或不同的条款。

邮寄地址：Texas Instruments, Post Office Box 655303, Dallas, Texas 75265
版权所有 © 2025，德州仪器 (TI) 公司