

TPS3710 宽 VIN 电压检测器

1 特性

- 符合汽车应用要求
- 具有符合 AEC-Q100 标准的下列特性：
 - 器件温度等级 1：-40°C 至 125°C 环境温度范围
 - 器件 HBM ESD 分类等级 2
 - 器件 CDM ESD 分类等级 C6
- 宽电源电压范围：1.8V 至 18V
- 可调节阈值：低至 400mV
- 高阈值精度：
 - 1.0% 过热
 - 0.25% 典型值
- 低静态电流：5.5μA (典型值)
- 开漏输出
- 内部迟滞：5.5mV (典型值)
- 温度范围：-40°C 至 +125°C
- 封装：
 - SOT-6
 - 1.5mm × 1.5mm WSON-6

2 应用

- 工业控制系统
- 嵌入式计算模块
- DSP、微控制器或微处理器应用
- 笔记本和台式机
- 便携式和电池供电类产品
- FPGA 和 ASIC 应用

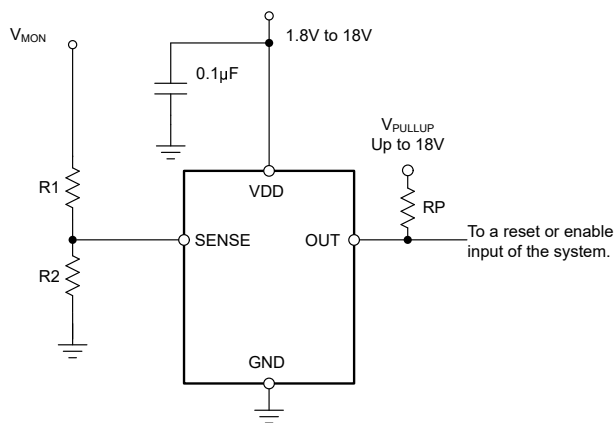

简化原理图

3 说明

TPS3710 宽电源电压检测器可在 1.8V 至 18V 的电压范围内运行。此器件具有一个内部基准电压为 400mV 的高精度比较器，和一个额定电压为 18V 的开漏输出，用于实现精确的电压检测。可以使用外部电阻设置监视电压。

当 SENSE 引脚上的电压下降至低于 (V_{IT-}) 时，OUT 引脚被驱动至低电平，而当电压返回到对应阈值 (V_{IT+}) 之上时，OUT 引脚变为高电平。TPS3710 的比较器包括用于滤波的内部迟滞来抑制短时毛刺脉冲，从而确保器件正确运行，不会引起误触发。

TPS3710 提供 6 引脚 SOT 封装和 1.5mm × 1.5mm 6 引脚 WSON 封装，额定工作结温范围为 -40°C 至 +125°C。

器件信息

器件型号	封装 ⁽¹⁾	封装尺寸 (标称值) ⁽²⁾
TPS3710	SOT (6)	2.90mm x 1.60mm
	WSON (6)	1.50mm x 1.50mm

- 如需了解所有可用封装，请参阅数据表末尾的封装选项附录。
- 封装尺寸 (长 × 宽) 为标称值，并包括引脚 (如适用)。

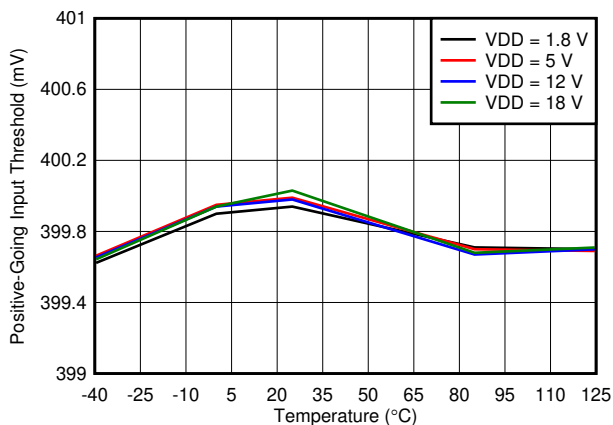

上升输入阈值电压 (V_{IT+}) 与温度间的关系



Table of Contents

1 特性	1	7 Application and Implementation	11
2 应用	1	7.1 Application Information.....	11
3 说明	1	7.2 Typical Application.....	13
4 Pin Configuration and Functions	3	7.3 Do's and Don'ts.....	14
5 Specifications	4	7.4 Power-Supply Recommendations.....	14
5.1 Absolute Maximum Ratings.....	4	7.5 Layout.....	15
5.2 ESD Ratings.....	4	8 Device and Documentation Support	16
5.3 Recommended Operating Conditions.....	4	8.1 Device Support.....	16
5.4 Thermal Information.....	4	8.2 Documentation Support.....	16
5.5 Electrical Characteristics.....	5	8.3 接收文档更新通知.....	16
5.6 Timing Requirements.....	6	8.4 支持资源.....	16
5.7 Switching Characteristics.....	6	8.5 Trademarks.....	16
5.8 Typical Characteristics.....	7	8.6 静电放电警告.....	16
6 Detailed Description	9	8.7 术语表.....	16
6.1 Overview.....	9	9 Revision History	16
6.2 Functional Block Diagram.....	9	10 Mechanical, Packaging, and Orderable Information	16
6.3 Feature Description.....	10		
6.4 Device Functional Modes.....	10		

4 Pin Configuration and Functions

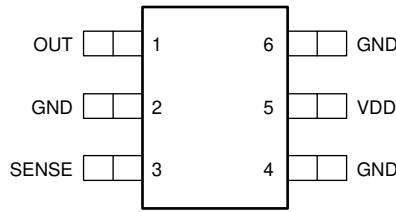

**图 4-1. DDC Package
6-Pin SOT
Top View**

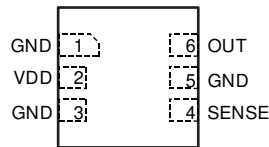

**图 4-2. DSE Package
6-Pin WSON
Top View**

表 4-1. Pin Functions

NAME	PIN		I/O	DESCRIPTION
	DDC	DSE		
GND	2, 4, 6	1, 3, 5	—	Connect all three pins to ground.
OUT	1	6	O	SENSE comparator open-drain output. OUT is driven low when the voltage at this comparator is below (V_{IT-}). The output goes high when the sense voltage returns above the respective threshold (V_{IT+}).
SENSE	3	4	I	This pin is connected to the voltage to be monitored with the use of an external resistor divider. When the voltage at this pin drops below the threshold voltage (V_{IT-}), OUT is driven low.
VDD	5	2	I	Supply voltage input. Connect a 1.8V to 18V supply to VDD to power the device. Good analog design practice is to place a 0.1 μ F ceramic capacitor close to this pin.

5 Specifications

5.1 Absolute Maximum Ratings

over operating temperature range (unless otherwise noted)⁽¹⁾

		MIN	MAX	UNIT
Voltage ⁽²⁾	VDD	- 0.3	20	V
	OUT	- 0.3	20	
	SENSE	- 0.3	7	
Current	OUT (output sink current)		40	mA
Temperature	Operating junction, T _J	- 40	125	°C
	Storage, T _{stg}	- 65	150	

- (1) Stresses beyond those listed under *Absolute Maximum Ratings* may cause permanent damage to the device. These are stress ratings only, which do not imply functional operation of the device at these or any other conditions beyond those indicated under *Recommended Operating Conditions*. Exposure to absolute-maximum-rated conditions for extended periods may affect device reliability.
- (2) All voltages are with respect to network ground pin.

5.2 ESD Ratings

		VALUE	UNIT
V _(ESD)	Electrostatic discharge	Human body model (HBM), per ANSI/ESDA/JEDEC JS-001, all pins ⁽¹⁾	±2500
		Charged device model (CDM), per JEDEC specification JESD22-C101, all pins ⁽²⁾	±1000

- (1) JEDEC document JEP155 states that 500V HBM allows safe manufacturing with a standard ESD control process.
- (2) JEDEC document JEP157 states that 250V CDM allows safe manufacturing with a standard ESD control process.

5.3 Recommended Operating Conditions

over operating temperature range (unless otherwise noted)

		MIN	NOM	MAX	UNIT
V _{DD}	Supply voltage	1.8		18	V
V _I	Input voltage	SENSE	0	6.5	V
V _O	Output voltage	OUT	0	18	V

5.4 Thermal Information

THERMAL METRIC ⁽¹⁾		TPS3710		UNIT
		DDC (SOT)	DSE (WSON)	
		6 PINS	6 PINS	
R _{θJA}	Junction-to-ambient thermal resistance	204.6	194.9	°C/W
R _{θJC(top)}	Junction-to-case (top) thermal resistance	50.5	128.9	°C/W
R _{θJB}	Junction-to-board thermal resistance	54.3	153.8	°C/W
ψ _{JT}	Junction-to-top characterization parameter	0.8	11.9	°C/W
ψ _{JB}	Junction-to-board characterization parameter	52.8	157.4	°C/W
R _{θJC(bot)}	Junction-to-case (bottom) thermal resistance	N/A	N/A	°C/W

- (1) For more information about traditional and new thermal metrics, see the *IC Package Thermal Metrics* application report, [SPRA953](#).

5.5 Electrical Characteristics

Over the operating temperature range of $T_J = -40^\circ\text{C}$ to $+125^\circ\text{C}$, and $1.8\text{V} < V_{DD} < 18\text{V}$ (unless otherwise noted). Typical values are at $T_J = 25^\circ\text{C}$ and $V_{DD} = 5\text{V}$.

PARAMETER		TEST CONDITIONS	MIN	TYP	MAX	UNIT
$V_{(POR)}$	Power-on reset voltage ⁽¹⁾	$V_{OLmax} = 0.2\text{V}$, output sink current = $15\mu\text{A}$			0.8	V
V_{IT+}	Positive-going input threshold voltage	$V_{DD} = 1.8\text{V}$	396	400	404	mV
		$V_{DD} = 18\text{V}$	396	400	404	
V_{IT-}	Negative-going input threshold voltage	$V_{DD} = 1.8\text{V}$	387	394.5	400	mV
		$V_{DD} = 18\text{V}$	387	394.5	400	
V_{hys}	Hysteresis voltage (hys = $V_{IT+} - V_{IT-}$)			5.5	12	mV
$I_{(SENSE)}$	Input current (at the SENSE pin)	$V_{DD} = 1.8\text{V}$ and 18V , $V_I = 6.5\text{V}$	- 25	1	25	nA
V_{OL}	Low-level output voltage	$V_{DD} = 1.3\text{V}$, output sink current = 0.4mA			250	mV
		$V_{DD} = 1.8\text{V}$, output sink current = 3mA			250	
		$V_{DD} = 5\text{V}$, output sink current = 5mA			250	
$I_{lk(OD)}$	Open-drain output leakage-current	$V_{DD} = 1.8\text{V}$ and 18V , $V_O = V_{DD}$			300	nA
		$V_{DD} = 1.8\text{V}$, $V_O = 18\text{V}$			300	
I_{DD}	Supply current	$V_{DD} = 1.8\text{V}$, no load		5.5	11	μA
		$V_{DD} = 5\text{V}$		6	13	
		$V_{DD} = 12\text{V}$		6	13	
		$V_{DD} = 18\text{V}$		7	13	
UVLO	Undervoltage lockout ⁽²⁾	V_{DD} falling	1.3		1.7	V

(1) The lowest supply voltage (V_{DD}) at which output is active; $t_{r(VDD)} > 15\mu\text{s/V}$. Below $V_{(POR)}$, the output cannot be determined.

(2) When V_{DD} falls below UVLO, OUT is driven low. The output cannot be determined below $V_{(POR)}$.

5.6 Timing Requirements

over operating temperature range (unless otherwise noted)

		MIN	NOM	MAX	UNIT
$t_{pd(HL)}$	High-to-low propagation delay ⁽¹⁾	18			μs
$t_{pd(LH)}$	Low-to-high propagation delay ⁽¹⁾	29			μs
$t_{d(start)}$	Start-up delay ⁽²⁾	150			μs

(1) High-to-low and low-to-high refers to the transition at the input pin (SENSE).

(2) During power on, V_{DD} must exceed 1.8V for at least 150 μs before the output is in a correct state.

5.7 Switching Characteristics

over operating temperature range (unless otherwise noted)

PARAMETER	TEST CONDITIONS	MIN	TYP	MAX	UNIT
t_r	Output rise time $V_{DD} = 5V, 10mV$ input overdrive, $R_P = 10k\ \Omega, V_O = (0.1\ to\ 0.9) \times V_{DD}$		2.2		μs
t_f	Output fall time $V_{DD} = 5V, 10mV$ input overdrive, $R_P = 10k\ \Omega, V_O = (0.1\ to\ 0.9) \times V_{DD}$		0.22		μs



图 5-1. Timing Diagram

5.8 Typical Characteristics

at $T_J = 25^\circ\text{C}$ and $V_{DD} = 5\text{V}$ (unless otherwise noted)

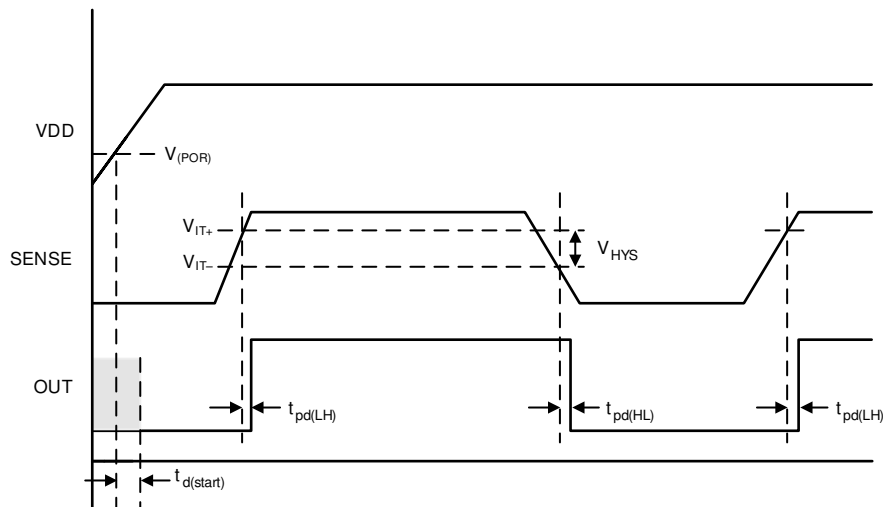

图 5-2. Supply Current (I_{DD}) vs Supply Voltage (V_{DD})



图 5-3. Rising Input Threshold Voltage (V_{IT+}) vs Temperature

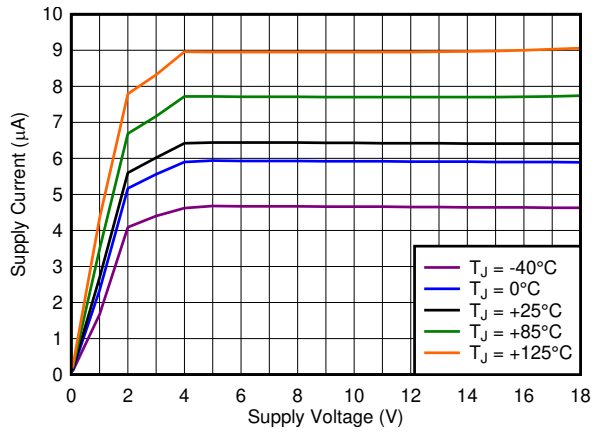

图 5-4. Hysteresis (V_{hys}) vs Temperature

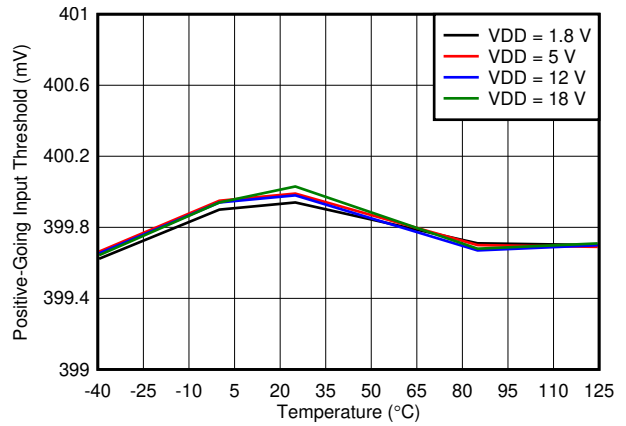

图 5-5. Propagation Delay vs Temperature (High-to-Low Transition at Sense)

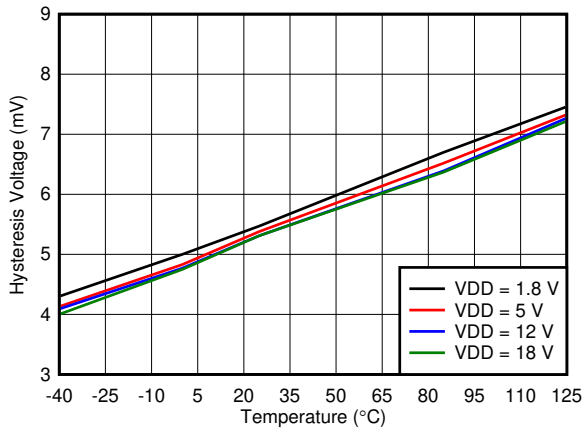

图 5-6. Propagation Delay vs Temperature (Low-to-High Transition at Sense)

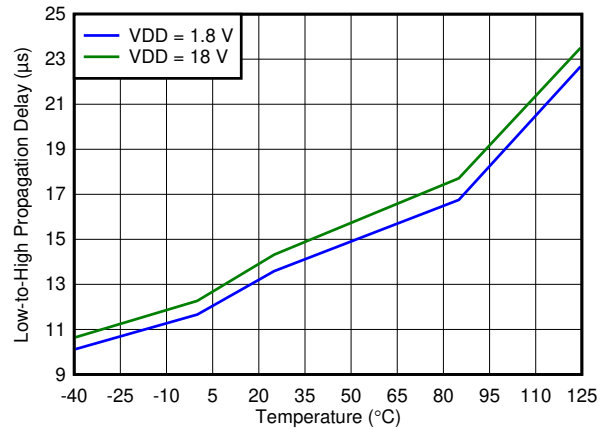

图 5-7. Minimum Pulse Width vs Threshold Overdrive Voltage
SENSE = negative spike below V_{IT-}

5.8 Typical Characteristics (continued)

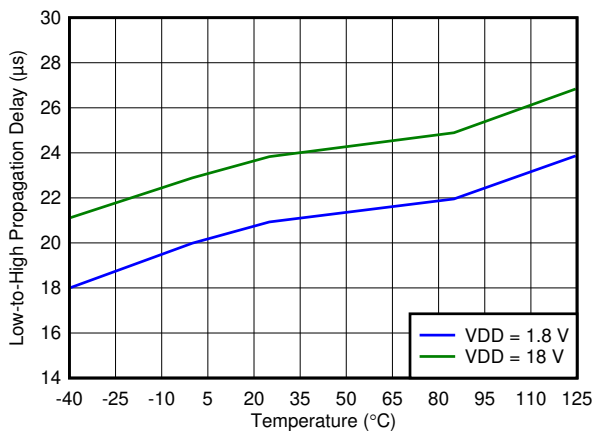
at $T_J = 25^\circ\text{C}$ and $V_{DD} = 5\text{V}$ (unless otherwise noted)

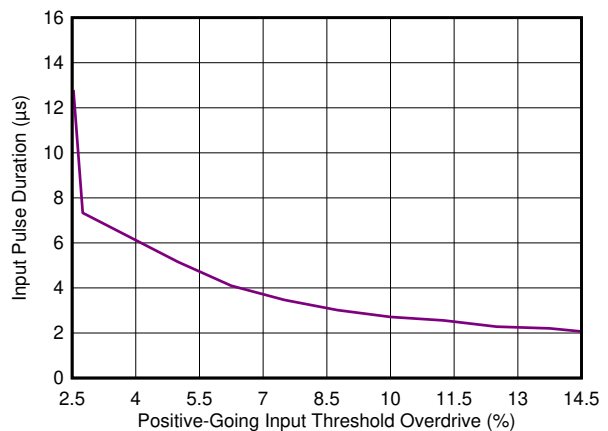

图 5-8. Supply Current (I_{DD}) vs Output Sink Current



图 5-9. Output Voltage Low (V_{OL}) vs Output Sink Current (-40°C)

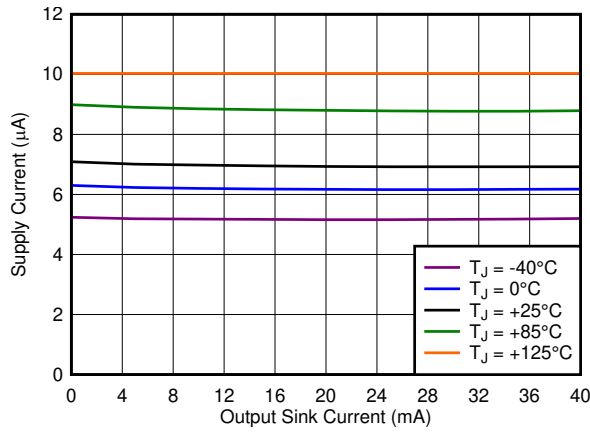

图 5-10. Output Voltage Low (V_{OL}) vs Output Sink Current (0°C)

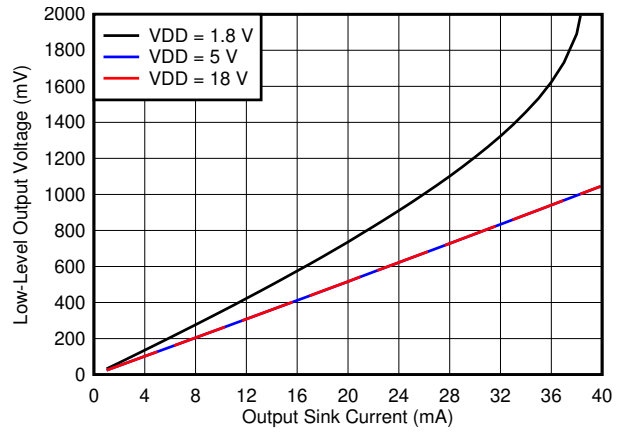

图 5-11. Output Voltage Low (V_{OL}) vs Output Sink Current (25°C)

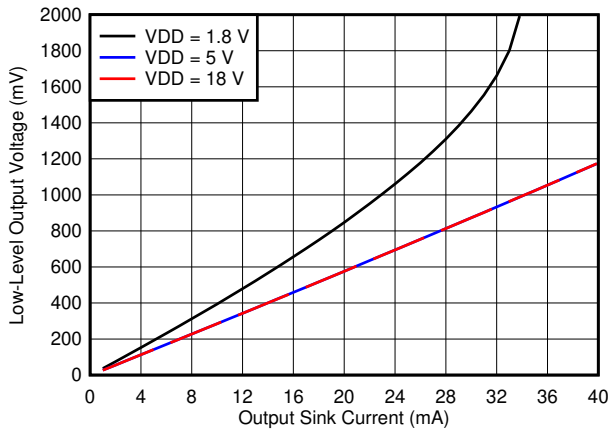

图 5-12. Output Voltage Low (V_{OL}) vs Output Sink Current (85°C)

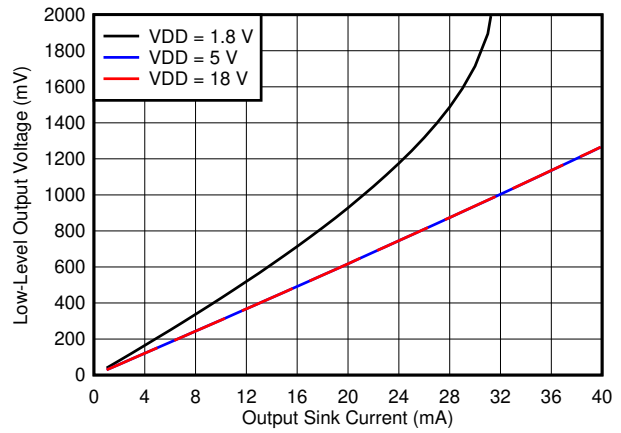

图 5-13. Output Voltage Low (V_{OL}) vs Output Sink Current (125°C)

6 Detailed Description

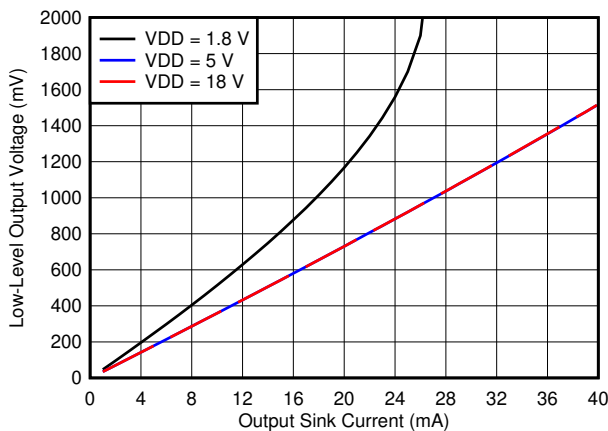
6.1 Overview

The TPS3710 provides precision voltage detection. The TPS3710 is a wide-supply voltage range (1.8V to 18V) device with a high-accuracy rising input threshold of 400mV (1% over temperature) and built-in hysteresis. The output is also rated to 18V, and can sink up to 40mA.

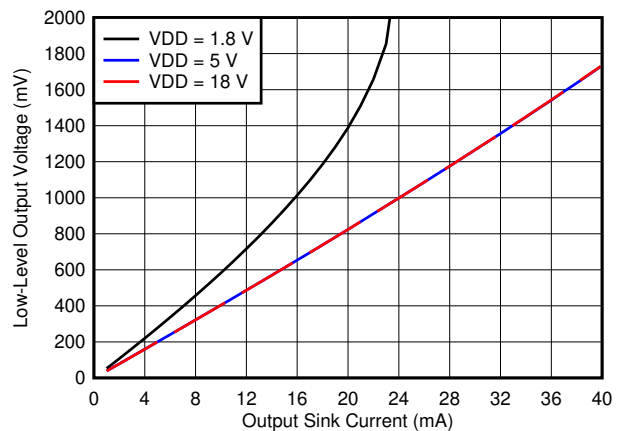
The TPS3710 asserts the output signal, as shown in 表 6-1. To monitor any voltage above 0.4V, set the input using an external resistor divider network. Broad voltage thresholds are supported that enable the device for use in a wide array of applications.

表 6-1. TPS3710 Truth Table

CONDITION	OUTPUT	STATUS
$SENSE > V_{IT+}$	OUT high	Output not asserted
$SENSE < V_{IT-}$	OUT low	Output asserted

6.2 Functional Block Diagram

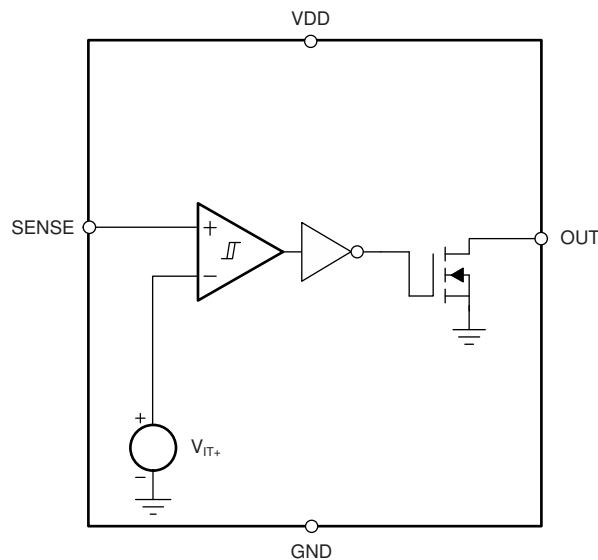

6.3 Feature Description

6.3.1 Input (SENSE)

The TPS3710 comparator has two inputs: one external input, and one input connected to the internal reference. The comparator rising threshold is trimmed to be equal to the reference voltage (400mV). The comparator also has a built-in falling hysteresis that makes the device less sensitive to supply-rail noise and provides stable operation.

The comparator input (SENSE) is able to swing from ground to 6.5V, regardless of the device supply voltage. Although not required in most cases, to reduce sensitivity to transients and layout parasitics for extremely noisy applications, place a 1nF to 10nF bypass capacitor at the comparator input.

OUT is driven to logic low when the input SENSE voltage drops below (V_{IT-}). When the voltage exceeds V_{IT+} , the output (OUT) goes to a high-impedance state; see [图 5-1](#).

6.3.2 Output (OUT)

In a typical TPS3710 application, the output is connected to a reset or enable input of the processor (such as a digital signal processor [DSP], central processing unit [CPU], field-programmable gate array [FPGA], or application-specific integrated circuit [ASIC]) or the output is connected to the enable input of a voltage regulator (such as a dc-dc converter or low-dropout regulator [LDO]).

The TPS3710 device provides an open-drain output (OUT). Use a pullup resistor to hold this line high when the output goes to high impedance (not asserted). To connect the output to another device at the correct interface-voltage level, connect a pullup resistor to the proper voltage rail. The TPS3710 output can be pulled up to 18V, independent of the device supply voltage.

[表 6-1](#) and the [节 6.3.1](#) section describe how the output is asserted or deasserted. See [图 5-1](#) for a timing diagram that describes the relationship between threshold voltage and the respective output.

6.3.3 Immunity to Input-Pin Voltage Transients

The TPS3710 is relatively immune to short voltage transient spikes on the sense pin. Sensitivity to transients depends on both transient duration and amplitude; see [图 5-7](#), *Minimum Pulse Width vs Threshold Overdrive Voltage*.

6.4 Device Functional Modes

6.4.1 Normal Operation ($V_{DD} > UVLO$)

When the voltage on V_{DD} is greater than 1.8V for at least 150 μ s, the OUT signal correspond to the voltage on SENSE as listed in [表 6-1](#).

6.4.2 Undervoltage Lockout ($V_{(POR)} < V_{DD} < UVLO$)

When the voltage on V_{DD} is less than the device UVLO voltage, and greater than the power-on reset voltage, $V_{(POR)}$, the OUT signal is asserted regardless of the voltage on SENSE.

6.4.3 Power-On Reset ($V_{DD} < V_{(POR)}$)

When the voltage on V_{DD} is lower than the required voltage to internally pull the asserted output to GND ($V_{(POR)}$), SENSE is in a high-impedance state and the OUT signal is undefined.

7 Application and Implementation

备注

以下应用部分中的信息不属于 TI 器件规格的范围，TI 不担保其准确性和完整性。TI 的客户应负责确定器件是否适用于其应用。客户应验证并测试其设计，以确保系统功能。

7.1 Application Information

The TPS3710 device is a wide-supply voltage comparator that operates over a V_{DD} range of 1.8V to 18V. The device has a high-accuracy comparator with an internal 400mV reference and an open-drain output rated to 18V for precision voltage detection. The device can be used as a voltage monitor. The monitored voltage are set with the use of external resistors.

7.1.1 V_{PULLUP} to a Voltage Other Than V_{DD}

The output is often tied to V_{DD} through a resistor. However, some applications may require the output to be pulled up to a higher or lower voltage than V_{DD} to correctly interface with the reset and enable pins of other devices.



图 7-1. Interfacing to a Voltage Other Than V_{DD}

7.1.2 Monitoring V_{DD}

Many applications monitor the same rail that is powering V_{DD}. In these applications the resistor divider is simply connected to the V_{DD} rail.

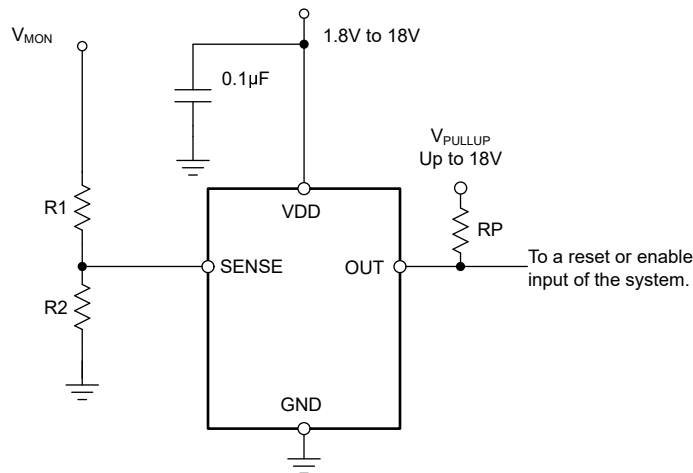

图 7-2. Monitoring the Same Voltage as V_{DD}

7.1.3 Monitoring a Voltage Other Than V_{DD}

Some applications monitor rails other than the one that is powering V_{DD}. In these types of applications the resistor divider used to set the desired threshold is connected to the rail that is being monitored.

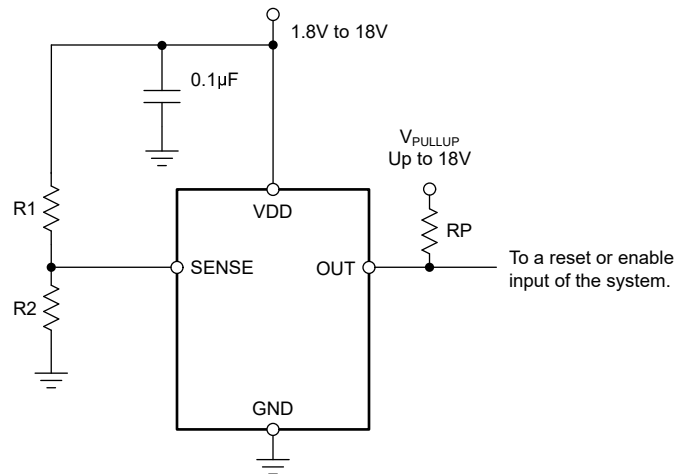
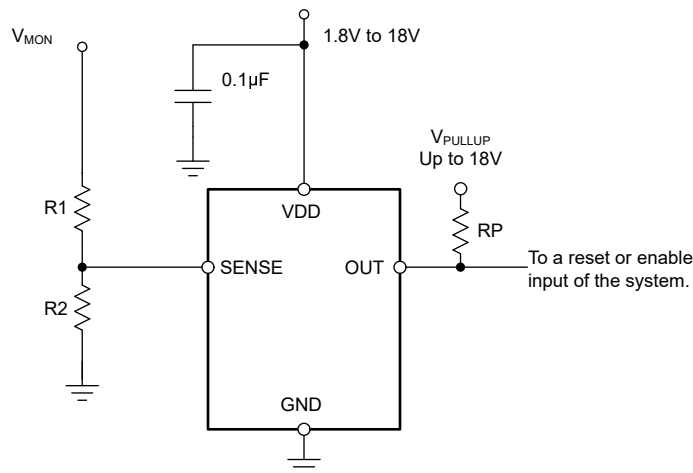

NOTE: The input can monitor a voltage greater than maximum V_{DD} with the use of an external resistor divider network.

图 7-3. Monitoring a Voltage Other Than V_{DD}

7.2 Typical Application

The TPS3710 device is a wide-supply voltage comparator that operates over a V_{DD} range of 1.8 to 18V. The monitored voltage is set with the use of external resistors, so the device can be used either as a precision voltage monitor.



图 7-4. Wide VIN Voltage Monitor

7.2.1 Design Requirements

For this design example, use the values summarized in 表 7-1 as the input parameters.

表 7-1. Design Parameters

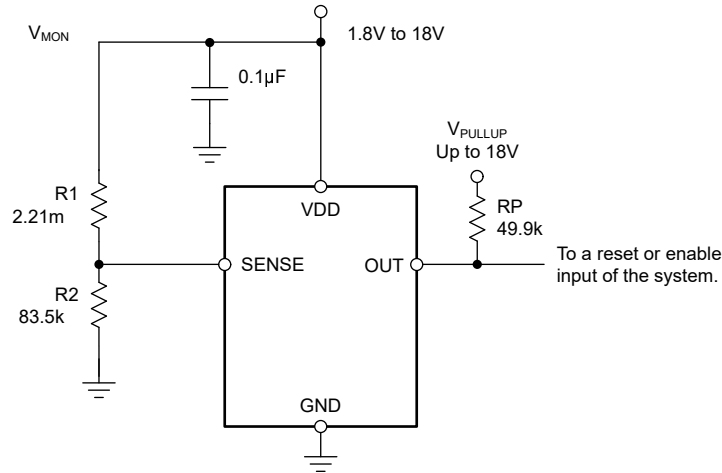
PARAMETER	DESIGN REQUIREMENT	DESIGN RESULT
Monitored voltage	12V nominal rail with maximum falling threshold of 10%	$V_{MON(UV)} = 10.99V$ (8.33%)

7.2.2 Detailed Design Procedure

7.2.2.1 Resistor Divider Selection

The resistor divider values and target threshold voltage can be calculated by using 方程式 1 to determine $V_{MON(UV)}$.

$$V_{MON(UV)} = \left(1 + \frac{R1}{R2}\right) \times V_{IT-} \quad (1)$$

where

- R1 and R2 are the resistor values for the resistor divider on the SENSEx pins
- $V_{MON(UV)}$ is the target voltage at which an undervoltage condition is detected

Choose R_{TOTAL} ($= R1 + R2$) so that the current through the divider is approximately 100 times higher than the input current at the SENSE pin. The resistors can have high values to minimize current consumption as a result of low input bias current without adding significant error to the resistive divider. For details on sizing input resistors, refer to application report [SLVA450, Optimizing Resistor Dividers at a Comparator Input](#), available for download from www.ti.com.

7.2.2.2 Pullup Resistor Selection

To make ensure the proper voltage level, the pullup resistor value is selected by ensuring that the pullup voltage divided by the resistor does not exceed the sink-current capability of the device. This confirmation is calculated by verifying that the pullup voltage minus the output-leakage current ($I_{kg(OD)}$) multiplied by the resistor is greater than the desired logic-high voltage. These values are specified in the [§ 5.5](#).

Use [方程式 2](#) to calculate the value of the pullup resistor.

$$\frac{(V_{HI} - V_{PU})}{I_{kg(OD)}} \geq R_{PU} \geq \frac{V_{PU}}{I_O} \quad (2)$$

7.2.2.3 Input Supply Capacitor

Although an input capacitor is not required for stability, for good analog design practice, connect a 0.1 μ F low equivalent series resistance (ESR) capacitor across the VDD and GND pins. A higher value capacitor can be necessary if large, fast rise-time load transients are anticipated, or if the device is not located close to the power source.

7.2.2.4 Sense Capacitor

Although not required in most cases, for extremely noisy applications, place a 1nF to 10nF bypass capacitor from the comparator input (SENSE) to the GND pin for good analog design practice. This capacitor placement reduces device sensitivity to transients.

7.2.3 Application Curve



图 7-5. Rising Input Threshold Voltage (V_{IT+}) vs Temperature

7.3 Do's and Don'ts

Do connect a 0.1 μ F decoupling capacitor from V_{DD} to GND for best system performance.

If the monitored rail is noisy, do connect a decoupling capacitor from the comparator input (sense) to GND.

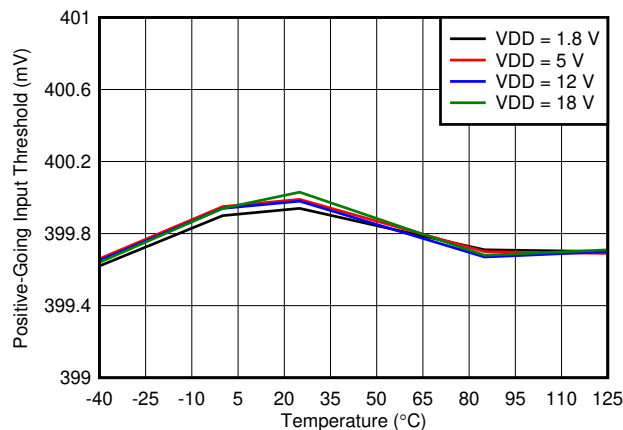
Don't use resistors for the voltage divider that cause the current through them to be less than 100 times the input current of the comparator without also accounting for the effect to the accuracy.

Don't use a pullup resistor that is too small, because the larger current sunk by the output then exceeds the desired low-level output voltage (V_{OL}).

7.4 Power-Supply Recommendations

This device operates from an input voltage supply range between 1.8V and 18V.

7.5 Layout

7.5.1 Layout Guidelines

Placing a 0.1 μ F capacitor close to the VDD pin to reduce the input impedance to the device is good analog design practice.

7.5.2 Layout Example



图 7-6. Layout Example

8 Device and Documentation Support

8.1 Device Support

8.1.1 Device Nomenclature

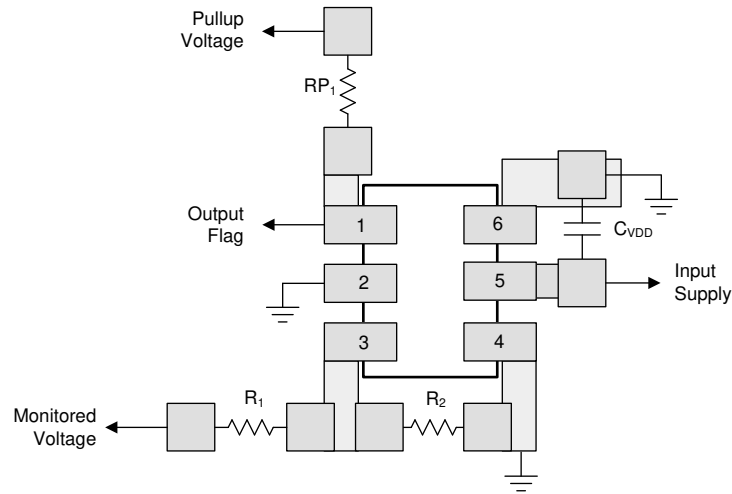
表 8-1. Device Nomenclature

PRODUCT	DESCRIPTION
TPS3710yyyz	yyy is package designator z is package quantity

8.2 Documentation Support

8.2.1 Related Documentation

For related documentation, see the following:

[Optimizing Resistor Dividers at a Comparator Input](#)

8.3 接收文档更新通知

要接收文档更新通知，请导航至 ti.com 上的器件产品文件夹。点击 [通知](#) 进行注册，即可每周接收产品信息更改摘要。有关更改的详细信息，请查看任何已修订文档中包含的修订历史记录。

8.4 支持资源

[TI E2E™ 中文支持论坛](#) 是工程师的重要参考资料，可直接从专家处获得快速、经过验证的解答和设计帮助。搜索现有解答或提出自己的问题，获得所需的快速设计帮助。

链接的内容由各个贡献者“按原样”提供。这些内容并不构成 TI 技术规范，并且不一定反映 TI 的观点；请参阅 TI 的 [使用条款](#)。

8.5 Trademarks

TI E2E™ is a trademark of Texas Instruments.

所有商标均为其各自所有者的财产。

8.6 静电放电警告



静电放电 (ESD) 会损坏这个集成电路。德州仪器 (TI) 建议通过适当的预防措施处理所有集成电路。如果不遵守正确的处理和安装程序，可能会损坏集成电路。

ESD 的损坏小至导致微小的性能降级，大至整个器件故障。精密的集成电路可能更容易受到损坏，这是因为非常细微的参数更改都可能会导致器件与其发布的规格不相符。

8.7 术语表

[TI 术语表](#) 本术语表列出并解释了术语、首字母缩略词和定义。

9 Revision History

注：以前版本的页码可能与当前版本的页码不同

Changes from Revision * (October 2015) to Revision A (February 2024)	Page
• 更新了整个文档中的表格、图和交叉参考的编号格式.....	1
• 通篇更新了图片，将 VDD 引脚处的电容值从 0.01uF 更改为 0.1uF.....	1

10 Mechanical, Packaging, and Orderable Information

The following pages include mechanical, packaging, and orderable information. This information is the most current data available for the designated devices. This data is subject to change without notice and revision of this document. For browser-based versions of this data sheet, refer to the left-hand navigation.

PACKAGING INFORMATION

Orderable Device	Status (1)	Package Type	Package Drawing	Pins	Package Qty	Eco Plan (2)	Lead finish/ Ball material (6)	MSL Peak Temp (3)	Op Temp (°C)	Device Marking (4/5)	Samples
TPS3710DDCR	ACTIVE	SOT-23-THIN	DDC	6	3000	RoHS & Green	NIPDAU	Level-2-260C-1 YEAR	-40 to 125	11AO	Samples
TPS3710DDCT	ACTIVE	SOT-23-THIN	DDC	6	250	RoHS & Green	NIPDAU	Level-2-260C-1 YEAR	-40 to 125	11AO	Samples
TPS3710DSER	ACTIVE	WSO	DSE	6	3000	RoHS & Green	NIPDAU	Level-1-260C-UNLIM	-40 to 125	1A	Samples
TPS3710DSET	ACTIVE	WSO	DSE	6	250	RoHS & Green	NIPDAU	Level-1-260C-UNLIM	-40 to 125	1A	Samples

(1) The marketing status values are defined as follows:

ACTIVE: Product device recommended for new designs.

LIFEBUY: TI has announced that the device will be discontinued, and a lifetime-buy period is in effect.

NRND: Not recommended for new designs. Device is in production to support existing customers, but TI does not recommend using this part in a new design.

PREVIEW: Device has been announced but is not in production. Samples may or may not be available.

OBSELETE: TI has discontinued the production of the device.

(2) **RoHS:** TI defines "RoHS" to mean semiconductor products that are compliant with the current EU RoHS requirements for all 10 RoHS substances, including the requirement that RoHS substance do not exceed 0.1% by weight in homogeneous materials. Where designed to be soldered at high temperatures, "RoHS" products are suitable for use in specified lead-free processes. TI may reference these types of products as "Pb-Free".

RoHS Exempt: TI defines "RoHS Exempt" to mean products that contain lead but are compliant with EU RoHS pursuant to a specific EU RoHS exemption.

Green: TI defines "Green" to mean the content of Chlorine (Cl) and Bromine (Br) based flame retardants meet JS709B low halogen requirements of <=1000ppm threshold. Antimony trioxide based flame retardants must also meet the <=1000ppm threshold requirement.

(3) MSL, Peak Temp. - The Moisture Sensitivity Level rating according to the JEDEC industry standard classifications, and peak solder temperature.

(4) There may be additional marking, which relates to the logo, the lot trace code information, or the environmental category on the device.

(5) Multiple Device Markings will be inside parentheses. Only one Device Marking contained in parentheses and separated by a "-" will appear on a device. If a line is indented then it is a continuation of the previous line and the two combined represent the entire Device Marking for that device.

(6) Lead finish/Ball material - Orderable Devices may have multiple material finish options. Finish options are separated by a vertical ruled line. Lead finish/Ball material values may wrap to two lines if the finish value exceeds the maximum column width.

Important Information and Disclaimer:The information provided on this page represents TI's knowledge and belief as of the date that it is provided. TI bases its knowledge and belief on information provided by third parties, and makes no representation or warranty as to the accuracy of such information. Efforts are underway to better integrate information from third parties. TI has taken and

continues to take reasonable steps to provide representative and accurate information but may not have conducted destructive testing or chemical analysis on incoming materials and chemicals. TI and TI suppliers consider certain information to be proprietary, and thus CAS numbers and other limited information may not be available for release.

In no event shall TI's liability arising out of such information exceed the total purchase price of the TI part(s) at issue in this document sold by TI to Customer on an annual basis.

OTHER QUALIFIED VERSIONS OF TPS3710 :

- Automotive : [TPS3710-Q1](#)

NOTE: Qualified Version Definitions:

- Automotive - Q100 devices qualified for high-reliability automotive applications targeting zero defects

TAPE AND REEL INFORMATION

QUADRANT ASSIGNMENTS FOR PIN 1 ORIENTATION IN TAPE

*All dimensions are nominal

Device	Package Type	Package Drawing	Pins	SPQ	Reel Diameter (mm)	Reel Width W1 (mm)	A0 (mm)	B0 (mm)	K0 (mm)	P1 (mm)	W (mm)	Pin1 Quadrant
TPS3710DDCR	SOT-23-THIN	DDC	6	3000	179.0	8.4	3.2	3.2	1.4	4.0	8.0	Q3
TPS3710DDCT	SOT-23-THIN	DDC	6	250	179.0	8.4	3.2	3.2	1.4	4.0	8.0	Q3
TPS3710DSET	WSO	DSE	6	250	179.0	8.4	1.8	1.8	1.0	4.0	8.0	Q2

TAPE AND REEL BOX DIMENSIONS

*All dimensions are nominal

Device	Package Type	Package Drawing	Pins	SPQ	Length (mm)	Width (mm)	Height (mm)
TPS3710DDCR	SOT-23-THIN	DDC	6	3000	213.0	191.0	35.0
TPS3710DDCT	SOT-23-THIN	DDC	6	250	213.0	191.0	35.0
TPS3710DSET	WSON	DSE	6	250	200.0	183.0	25.0

EXAMPLE BOARD LAYOUT

DDC0006A

SOT-23 - 1.1 max height

SMALL OUTLINE TRANSISTOR

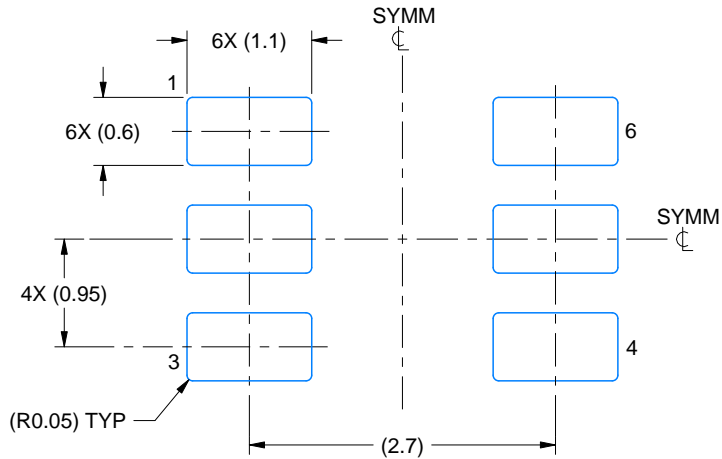

LAND PATTERN EXAMPLE
EXPLODED METAL SHOWN
SCALE:15X



SOLDEMASK DETAILS

4214841/E 08/2024

NOTES: (continued)

- 4. Publication IPC-7351 may have alternate designs.
- 5. Solder mask tolerances between and around signal pads can vary based on board fabrication site.

EXAMPLE STENCIL DESIGN

DDC0006A

SOT-23 - 1.1 max height

SMALL OUTLINE TRANSISTOR



SOLDER PASTE EXAMPLE
BASED ON 0.125 THICK STENCIL
SCALE:15X

4214841/E 08/2024

NOTES: (continued)

6. Laser cutting apertures with trapezoidal walls and rounded corners may offer better paste release. IPC-7525 may have alternate design recommendations.
7. Board assembly site may have different recommendations for stencil design.

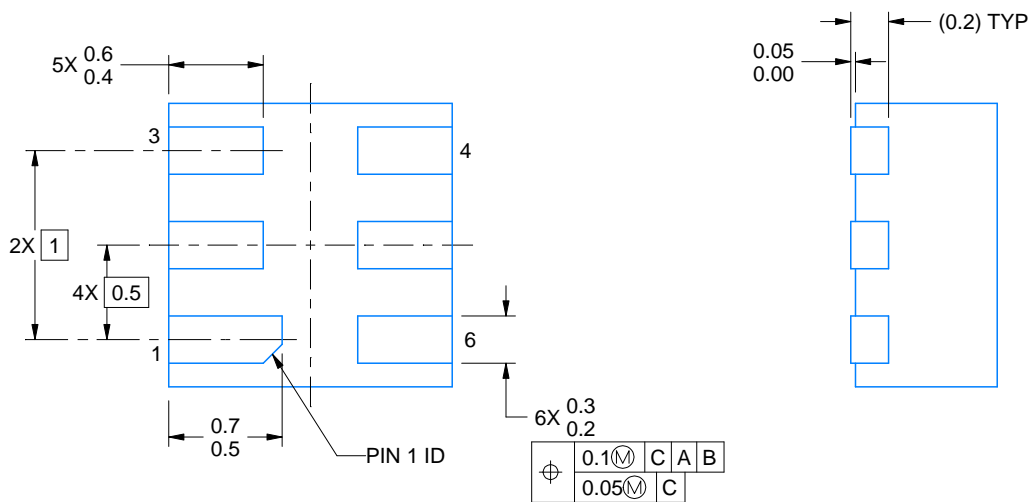
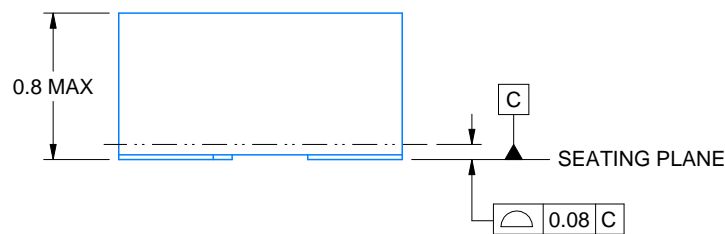
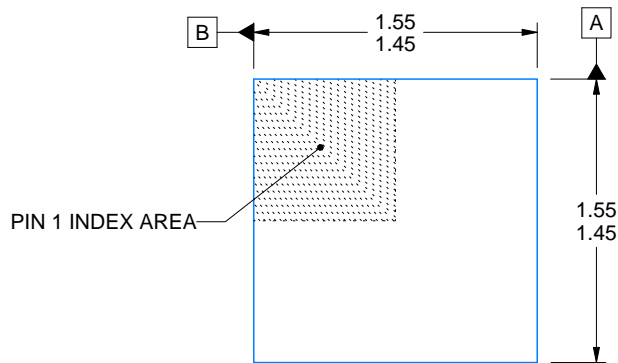
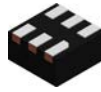

4220552/B 01/2024

NOTES:

1. All linear dimensions are in millimeters. Any dimensions in parenthesis are for reference only. Dimensioning and tolerancing per ASME Y14.5M.
2. This drawing is subject to change without notice.

EXAMPLE BOARD LAYOUT

DSE0006A

WSON - 0.8 mm max height

PLASTIC SMALL OUTLINE - NO LEAD

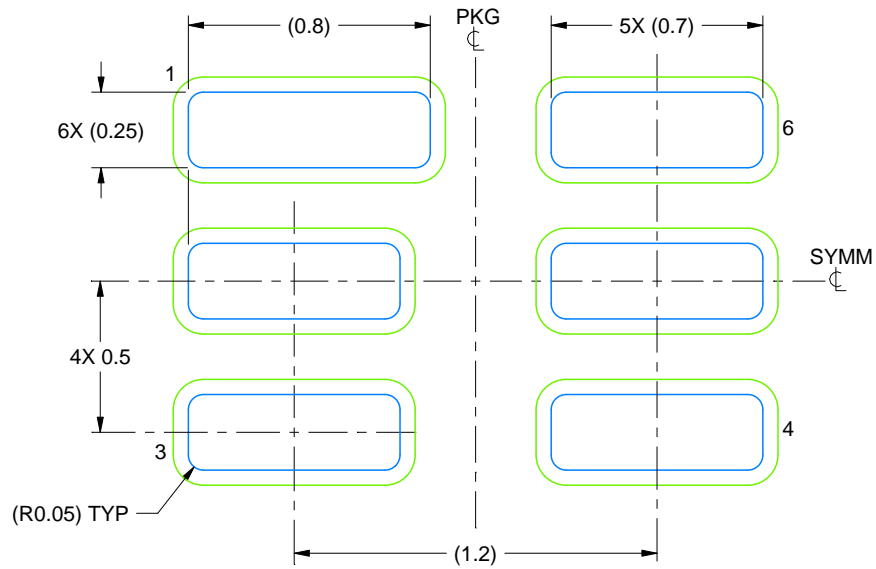

LAND PATTERN EXAMPLE
SCALE:40X

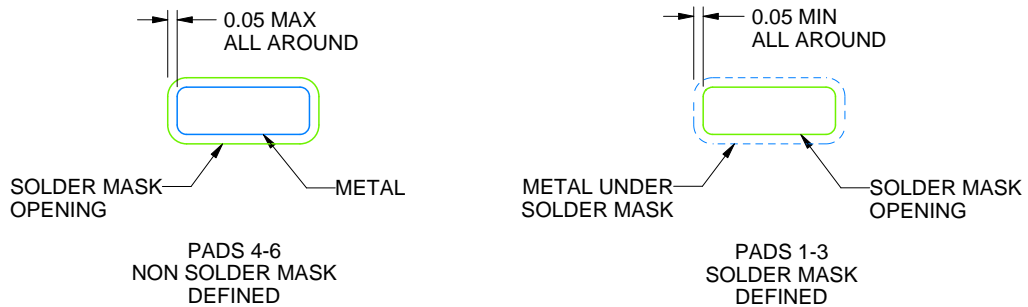

SOLDER MASK DETAILS

4220552/B 01/2024

NOTES: (continued)

3. For more information, see Texas Instruments literature number SLUA271 (www.ti.com/lit/slua271).

EXAMPLE STENCIL DESIGN

DSE0006A

WSON - 0.8 mm max height

PLASTIC SMALL OUTLINE - NO LEAD

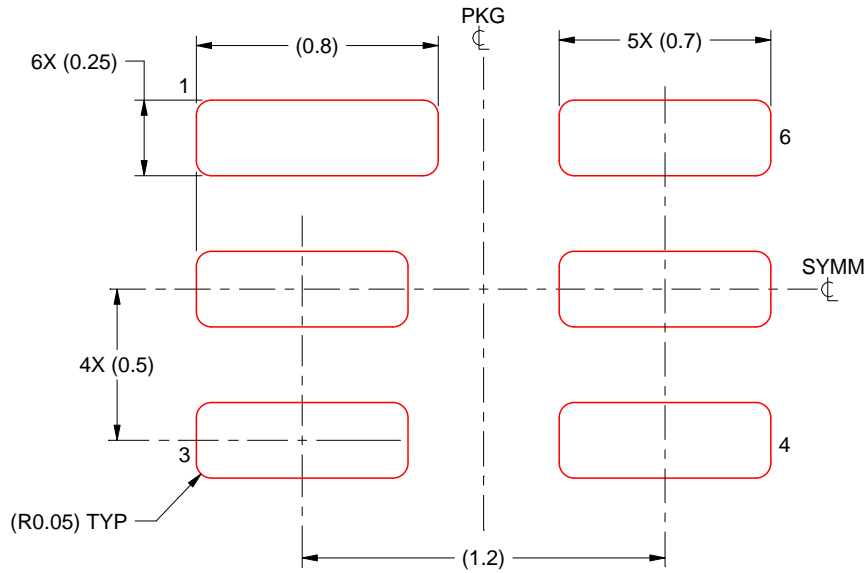

SOLDER PASTE EXAMPLE
BASED ON 0.125 mm THICK STENCIL
SCALE:40X

NOTES: (continued)

4. Laser cutting apertures with trapezoidal walls and rounded corners may offer better paste release. IPC-7525 may have alternate design recommendations.

重要通知和免责声明

TI“按原样”提供技术和可靠性数据（包括数据表）、设计资源（包括参考设计）、应用或其他设计建议、网络工具、安全信息和其他资源，不保证没有瑕疵且不做任何明示或暗示的担保，包括但不限于对适销性、某特定用途方面的适用性或不侵犯任何第三方知识产权的暗示担保。

这些资源可供使用 TI 产品进行设计的熟练开发人员使用。您将自行承担以下全部责任：(1) 针对您的应用选择合适的 TI 产品，(2) 设计、验证并测试您的应用，(3) 确保您的应用满足相应标准以及任何其他功能安全、信息安全、监管或其他要求。

这些资源如有变更，恕不另行通知。TI 授权您仅可将这些资源用于研发本资源所述的 TI 产品的相关应用。严禁以其他方式对这些资源进行复制或展示。您无权使用任何其他 TI 知识产权或任何第三方知识产权。您应全额赔偿因在这些资源的使用中对 TI 及其代表造成的任何索赔、损害、成本、损失和债务，TI 对此概不负责。

TI 提供的产品受 [TI 的销售条款](#) 或 [ti.com](#) 上其他适用条款/TI 产品随附的其他适用条款的约束。TI 提供这些资源并不会扩展或以其他方式更改 TI 针对 TI 产品发布的适用的担保或担保免责声明。

TI 反对并拒绝您可能提出的任何其他或不同的条款。

邮寄地址：Texas Instruments, Post Office Box 655303, Dallas, Texas 75265
版权所有 © 2025，德州仪器 (TI) 公司