

# 具有电压前馈功能的 TPS40077 4.5V 至 28V 输入、电压模式、同步降压控制器

## 1 特性

- 在 4.5V 至 28V 输入范围内运行
- 固定频率高达 1MHz 的可编程电压模式控制器
- 预测性栅极驱动反跨导电路
- <1% 内部 700mV 基准电压
- 用于高侧和同步 N 沟道金属氧化物半导体场效应晶体管 (MOSFET) 的内部栅极驱动输出
- 16 引脚 PowerPAD™ 封装
- 热关断保护
- 与预偏置功能兼容
- 功率级关断功能
- 可编程高侧感应短路保护

## 2 应用

- 电源模块
- 网络/电信
- PCI Express
- 工业
- 服务器

## 3 说明

TPS40077 是一款中压、宽输入电压 (4.5V 至 28V) 同步降压控制器，可以为多种用户可编程功能的设计提供灵活性，包括软启动、欠压锁定 (UVLO)、工作频率、电压前馈以及高侧 FET 检测短路保护。

TPS40077 使用第二代预测性栅极驱动器来驱动外部 N 沟道 MOSFET，以便最大限度降低低侧 FET 的体二极管的导电能力，并最大限度提高效率。其支持预偏置输出，方式是在闭环软启动所需的电压大于预偏置电压之前，禁止打开低侧 FET。电压前馈功能可在发生输入瞬变时即时响应，并在宽输入电压工作范围内提供恒定的 PWM 增益以降低补偿要求。可编程的短路保护提供了故障电流限制和断续恢复功能，可最大限度降低输出短路时的功率耗散。16 引脚 PowerPAD 封装带来良好的热性能和紧凑的外形。

### 器件信息(1)

器件型号	封装	封装尺寸 (标称值)
TPS40077	HTSSOP (16)	5.00mm x 4.40mm

(1) 如需了解所有可用封装，请参阅数据表末尾的可订购产品附录。

### 简化应用示意图

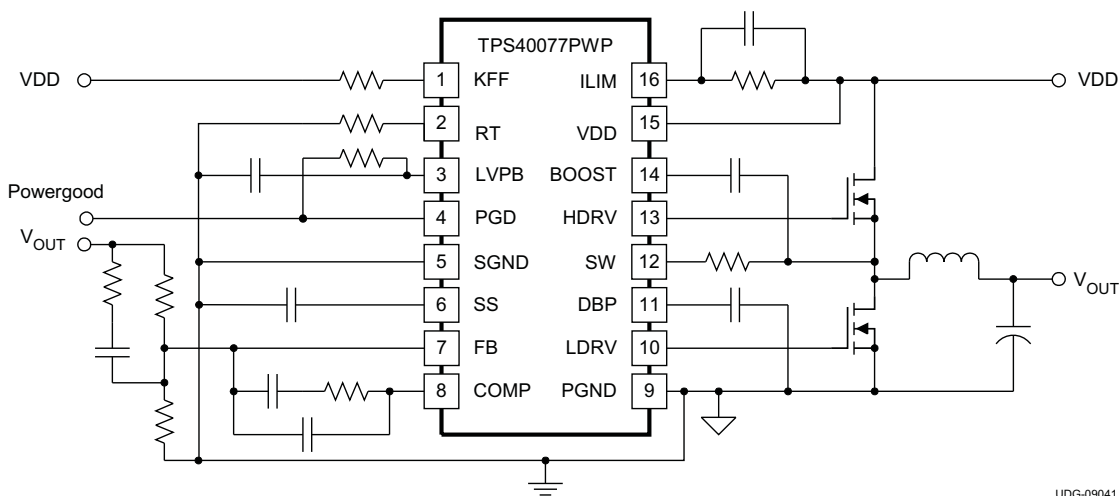

## 目录

<b>1</b>	特性 .....	<b>1</b>	<b>8</b>	<b>Application and Implementation</b> .....	<b>21</b>
<b>2</b>	应用 .....	<b>1</b>	8.1	Application Information.....	21
<b>3</b>	说明 .....	<b>1</b>	8.2	Typical Applications .....	21
<b>4</b>	修订历史记录 .....	<b>2</b>	8.3	Additional System Examples .....	32
<b>5</b>	<b>Pin Configuration and Functions</b> .....	<b>3</b>	<b>9</b>	<b>Layout</b> .....	<b>34</b>
<b>6</b>	<b>Specifications</b> .....	<b>5</b>	9.1	Layout Guidelines .....	34
6.1	Absolute Maximum Ratings .....	5	<b>10</b>	<b>器件和文档支持</b> .....	<b>35</b>
6.2	ESD Ratings.....	5	10.1	器件支持 .....	35
6.3	Recommended Operating Conditions.....	5	10.2	文档支持 .....	35
6.4	Electrical Characteristics.....	6	10.3	接收文档更新通知 .....	35
6.5	Typical Characteristics .....	8	10.4	社区资源 .....	35
<b>7</b>	<b>Detailed Description</b> .....	<b>12</b>	10.5	商标 .....	35
7.1	Overview .....	12	10.6	静电放电警告 .....	35
7.2	Functional Block Diagram .....	12	10.7	Glossary .....	35
7.3	Feature Description.....	13	<b>11</b>	<b>机械、封装和可订购信息</b> .....	<b>35</b>
7.4	Programming.....	17			

## 4 修订历史记录

注：之前版本的页码可能与当前版本有所不同。

<b>Changes from Revision D (April 2009) to Revision E</b>	<b>Page</b>
• 添加了特性说明部分、器件功能模式、应用和实施部分、电源建议部分、布局部分、器件和文档支持部分以及机械、封装和可订购信息部分；编辑性更改 .....	1
• Deleted Ordering Information table .....	3
• Moved Package Dissipation Ratings table to <i>Power Dissipation</i> .....	16

## 5 Pin Configuration and Functions

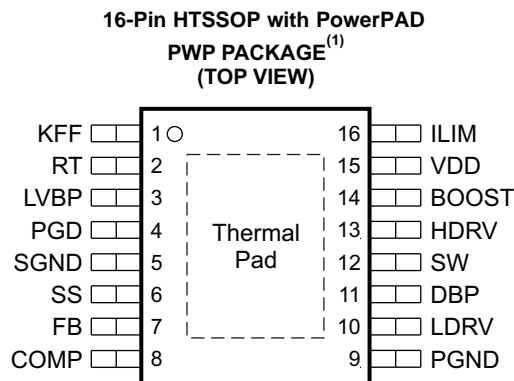

P0047-01

- (1) For more information on the PWP package, see the *PowerPAD Thermally Enhanced Package* technical brief (SLMA002).

### Pin Functions

PIN		I/O	DESCRIPTION
NO.	NAME		
1	KFF	I	A resistor connected from this pin to VIN programs the amount of feed-forward voltage. The current fed into this pin is internally divided by 25 and used to control the slope of the PWM ramp and program UVLO. Nominal voltage at this pin is maintained at 400 mV.
2	RT	I	A resistor is connected from this pin to ground to set the internal oscillator and switching frequency.
3	LVBP	O	4.2-V reference used for internal device logic only. This pin should be bypassed by a 0.1- $\mu$ F ceramic capacitor. External loads that are less than 1 mA and electrically quiet may be applied.
4	PGD	O	This is an open-drain output that pulls to ground when soft start is active, or when the FB pin is outside a $\pm 10\%$ band around VREF.
5	SGND	—	Signal ground reference for the device. Low-level quiet circuitry around the IC should connect to this pin. This pin should be connected to the thermal pad under the IC, and that thermal pad should connect to the PGND pin. Do not allow power currents to flow in the thermal pad or in the SGND part of the ground for best results.
6	SS	I	Soft-start programming pin. A capacitor connected from this pin to GND programs the soft-start time. The capacitor is charged with an internal current source of 12 $\mu$ A. The resulting voltage ramp on the SS pin is used as a second noninverting input to the error amplifier. The voltage at this error amplifier input is approximately 1 V less than that on the SS pin. Output voltage regulation is controlled by the SS voltage ramp until the voltage on the SS pin reaches the internal offset voltage of 1 V plus the internal reference voltage of 700 mV. If SS is pulled below 225 mV, the device goes into a shutdown state where the power FETs are turned off and the prebias circuitry is reset. If the programmed UVLO voltage is below 6 V, connect a 330-k $\Omega$ resistor in parallel with the SS capacitor. Also provides timing for fault recovery attempts.
7	FB	I	Inverting input to the error amplifier. In normal operation, the voltage on this pin is equal to the internal reference voltage, 0.7 V.
8	COMP	O	Output of the error amplifier, input to the PWM comparator. A feedback network is connected from this pin to the FB pin to compensate the overall loop. The COMP pin is internally clamped to 3.4 V.
9	PGND	—	Power ground reference for the device. There should be a low-impedance path from this pin to the source(s) of the lower MOSFET(s).
10	LDRV	O	Gate drive for the N-channel synchronous rectifier. This pin switches from DBP (MOSFET on) to ground (MOSFET off). For proper operation, the total gate charge of the MOSFET connected to LDRV should be less than 50 nC.
11	DBP	O	8-V reference used for the gate drive of the N-channel synchronous rectifier. This pin should be bypassed to ground with a 1- $\mu$ F ceramic capacitor.
12	SW	I	This pin is connected to the switched node of the converter. It is used for short-circuit sensing and gate-drive timing information and is the return for the high-side driver. A 1.5- $\Omega$ resistor is required in series with this pin for protection against substrate current issues.
13	HDRV	O	Floating gate drive for the high-side N-channel MOSFET. This pin switches from BOOST (MOSFET on) to SW (MOSFET off).

**Pin Functions (continued)**

PIN		I/O	DESCRIPTION
NO.	NAME		
14	BOOST	I	The peak voltage on BOOST is equal to the SW node voltage plus the voltage present at DBP less the bootstrap diode drop. This drop can be 1.4 V for the internal bootstrap diode or 300 mV for an external Schottky diode. The voltage differential between this pin and SW is the available drive voltage for the high-side FET.
15	VDD	I	Supply voltage for the device.
16	ILIM	I	Short-circuit-protection programming pin. This pin is used to set the short circuit detection threshold. An internal current sink from this pin to ground sets a voltage drop across an external resistor connected from this pin to VDD. The voltage on this pin is compared to the voltage drop ( $V_{VDD} - V_{SW}$ ) across the high side N-channel MOSFET during conduction. Just prior to the beginning of a switching cycle, this pin is pulled to approximately $V_{DD}/2$ and released when SW is within 2 V of $V_{DD}$ or after a timeout (the precondition time), whichever occurs first. Placing a capacitor across the resistor from ILIM to VDD allows the ILIM threshold to decrease during the switch-on time, effectively programming the ILIM blanking time. See <i>Application Information</i> .

## 6 Specifications

### 6.1 Absolute Maximum Ratings

over operating free-air temperature range (unless otherwise noted)<sup>(1)</sup>

		MIN	MAX	UNIT
Input voltage, $V_{DD}$	VDD, ILIM		30	V
	COMP, FB, KFF, PGD, LVBP	-0.3	6	
	SW	-0.3	40	
	SW, transient (<50 ns)		-2.5	
Output voltage, $V_{OUT}$	COMP, KFF, RT, SS	-0.3	6	V
	VBOOST		50	
	DBP		10.5	
	LVBP		6	
Output current source, $I_{OUT}$ (LDRV, HDRV)			1.5	A
Output current sink, $I_{OUT}$	LDRV, HDRV		2	A
	KFF		10	
Output current	RT		1	mA
	LVBP		1.5	
Lead temperature, 1.6 mm (1/16 inch) from case (10 s)			260	°C
Operating junction temperature, $T_J$		-40	125	°C
Storage temperature, $T_{stg}$		-55	150	°C

- (1) Stresses beyond those listed under *Absolute Maximum Ratings* may cause permanent damage to the device. These are stress ratings only, which do not imply functional operation of the device at these or any other conditions beyond those indicated under *Recommended Operating Conditions*. Exposure to absolute-maximum-rated conditions for extended periods may affect device reliability.

### 6.2 ESD Ratings

		VALUE	UNIT
$V_{(ESD)}$ Electrostatic discharge	Human-body model (HBM), per ANSI/ESDA/JEDEC JS-001 <sup>(1)</sup>	±2000	V
	Charged-device model (CDM), per JEDEC specification JESD22-C101 <sup>(2)</sup>	±1500	

- (1) JEDEC document JEP155 states that 500-V HBM allows safe manufacturing with a standard ESD control process.

- (2) JEDEC document JEP157 states that 250-V CDM allows safe manufacturing with a standard ESD control process.

### 6.3 Recommended Operating Conditions

over operating free-air temperature range (unless otherwise noted)

		MIN	NOM	MAX	UNIT
$V_{DD}$	Input voltage	4.5		28	V
$T_A$	Operating free-air temperature	-40		85	°C

## 6.4 Electrical Characteristics

$T_A = -40^{\circ}\text{C}$  to  $85^{\circ}\text{C}$ ,  $V_{IN} = 12\text{ V}_{\text{dc}}$ ,  $R_T = 90.9\text{ k}\Omega$ ,  $I_{\text{KFF}} = 300\text{ }\mu\text{A}$ ,  $f_{\text{SW}} = 500\text{ kHz}$ , and all parameters at zero power dissipation (unless otherwise noted).

PARAMETER		TEST CONDITIONS	MIN	TYP	MAX	UNIT
$V_{\text{VDD}}$	Input voltage range, $V_{\text{IN}}$		4.5		28	V
$I_{\text{VDD}}$	Quiescent current	Output drivers not switching		2.5	3.5	mA
$V_{\text{LVBP}}$	Output voltage	$T_A = T_J = 25^{\circ}\text{C}$	3.9	4.2	4.5	V
<b>OSCILLATOR/RAMP GENERATOR</b>						
$f_{\text{OSC}}$	Accuracy		450	500	550	kHz
$V_{\text{RAMP}}$	PWM ramp voltage <sup>(1)</sup>	$V_{\text{PEAK}} - V_{\text{VAL}}$		2		V
$V_{\text{RT}}$	RT voltage		2.23	2.4	2.58	V
$t_{\text{ON}}$	Minimum output pulse time <sup>(1)</sup>	$C_{\text{HDRV}} = 0\text{ nF}$			150	ns
	Maximum duty cycle	$V_{\text{FB}} = 0\text{ V}$ , $100\text{ kHz} \leq f_{\text{SW}} \leq 500\text{ kHz}$	84%		93%	
		$V_{\text{FB}} = 0\text{ V}$ , $f_{\text{SW}} = 1\text{ MHz}$	76%		93%	
$V_{\text{KFF}}$	Feed-forward voltage		0.35	0.4	0.45	V
$I_{\text{KFF}}$	Feed-forward current operating range <sup>(1)</sup>		20		1100	$\mu\text{A}$
<b>SOFT START</b>						
$I_{\text{SS}}$	Charge current		7	12	17	$\mu\text{A}$
$t_{\text{DSCH}}$	Discharge time	$C_{\text{SS}} = 3.9\text{ nF}$	25		75	$\mu\text{s}$
$t_{\text{SS}}$	Soft-start time	$C_{\text{SS}} = 3.9\text{ nF}$ , $V_{\text{SS}}$ rising from 0.7 V to 1.6 V	210	290	500	$\mu\text{s}$
$V_{\text{SSSD}}$	Turnon threshold		310	365	420	mV
	Shutdown threshold		225	275	325	
$V_{\text{SSSDH}}$	Shutdown threshold hysteresis		35		150	mV
$V_{\text{DBP}}$	Output voltage	$V_{\text{DD}} > 10\text{ V}$	7	8	9	V
		$V_{\text{DD}} = 4.5\text{ V}$ , $I_{\text{OUT}} = 25\text{ mA}$	4	4.3		
<b>ERROR AMPLIFIER</b>						
$V_{\text{FB}}$	Feedback regulation voltage total variation	$T_J = 25^{\circ}\text{C}$	0.698	0.7	0.704	V
		$0^{\circ}\text{C} \leq T_J \leq 85^{\circ}\text{C}$	0.69	0.7	0.707	
		$-40^{\circ}\text{C} \leq T_J \leq 85^{\circ}\text{C}$	0.69	0.7	0.715	
$V_{\text{SS}}$	Soft-start offset from $V_{\text{SS}}$ <sup>(1)</sup>	Offset from $V_{\text{SS}}$ to error amplifier		1		V
$G_{\text{BW}}$	Gain bandwidth <sup>(1)</sup>		5	10		MHz
$A_{\text{VOL}}$	Open-loop gain		50			dB
$I_{\text{SRC}}$	Output source current		2.5	4.5		mA
$I_{\text{SINK}}$	Output sink current		2.5	6		mA
$I_{\text{BIAS}}$	Input bias current	$V_{\text{FB}} = 0.7\text{ V}$	-250		0	nA
<b>SHORT-CIRCUIT CURRENT PROTECTION</b>						
$I_{\text{LIM}}$	Current sink into current limit		80	105	125	$\mu\text{A}$
$V_{\text{ILIM(orst)}}$	Current limit offset voltage ( $V_{\text{SW}} - V_{\text{ILIM}}$ )	$V_{\text{ILIM}} = 11.5\text{ V}$ , $V_{\text{VDD}} = 12\text{ V}$	-75	-50	-30	mV
$t_{\text{HSC}}$	Minimum HDRV pulse duration	During short circuit		135	225	ns
	Propagation delay to output <sup>(1)</sup>			50		ns
$t_{\text{BLANK}}$	Blanking time <sup>(1)</sup>			50		ns
$t_{\text{OFF}}$	Off time during a fault (SS cycle times)			7		Cycles
$V_{\text{SW}}$	Switching level to end precondition ( $V_{\text{VDD}} - V_{\text{SW}}$ ) <sup>(1)</sup>			2		V
$t_{\text{PC}}$	Precondition time <sup>(1)</sup>				100	ns
$V_{\text{ILIM}}$	Current limit precondition voltage threshold <sup>(1)</sup>			6.8		V

(1) Ensured by design. Not production tested.

**Electrical Characteristics (continued)**

$T_A = -40^{\circ}\text{C}$  to  $85^{\circ}\text{C}$ ,  $V_{IN} = 12\text{ V}_{dc}$ ,  $R_T = 90.9\text{ k}\Omega$ ,  $I_{KFF} = 300\text{ }\mu\text{A}$ ,  $f_{SW} = 500\text{ kHz}$ , and all parameters at zero power dissipation (unless otherwise noted).

PARAMETER		TEST CONDITIONS	MIN	TYP	MAX	UNIT
<b>OUTPUT DRIVERS</b>						
$t_{HFALL}$	High-side driver fall time (HDRV – SW) <sup>(1)</sup>	$C_{HDRV} = 2200\text{ pF}$		36		ns
$t_{HRISE}$	High-side driver rise time (HDRV – SW) <sup>(1)</sup>			48		ns
$t_{HFALL}$	High-side driver fall time (HDRV – SW) <sup>(1)</sup>	$C_{HDRV} = 2200\text{ pF}$ , $V_{VDD} = 4.5\text{ V}$ , $0.2\text{ V} \leq V_{SS} \leq 4\text{ V}$		72		ns
$t_{HRISE}$	High-side driver rise time (HDRV – SW) <sup>(1)</sup>			96		ns
$t_{LFALL}$	Low-side driver fall time <sup>(1)</sup>	$C_{LDRV} = 2200\text{ pF}$		24		ns
$t_{LRISE}$	Low-side driver rise time <sup>(1)</sup>			48		ns
$t_{LFALL}$	Low-side driver fall time <sup>(1)</sup>	$C_{LDRV} = 2200\text{ pF}$ , $V_{VDD} = 4.5\text{ V}$ , $0.2\text{ V} \leq V_{SS} \leq 4\text{ V}$		48		ns
$t_{LRISE}$	Low-side driver rise time <sup>(1)</sup>			96		ns
$V_{OH}$	High-level output voltage, HDRV ( $V_{BOOST} - V_{HDRV}$ )	$I_{HDRV} = -0.01\text{ A}$		0.7	1	V
		$I_{HDRV} = -0.1\text{ A}$		0.95	1.3	
$V_{OL}$	Low-level output voltage, HDRV ( $V_{HDRV} - V_{SW}$ )	$I_{HDRV} = 0.01\text{ A}$		0.06	0.1	V
		$I_{HDRV} = 0.1\text{ A}$		0.65	1	
$V_{OH}$	High-level output voltage, LDRV ( $V_{DBP} - V_{LDRV}$ )	$I_{LDRV} = -0.01\text{ A}$		0.65	1	V
		$I_{LDRV} = -0.1\text{ A}$		0.875	1.2	
$V_{OL}$	Low-level output voltage, LDRV	$I_{LDRV} = 0.01\text{ A}$		0.03	0.05	V
		$I_{LDRV} = 0.1\text{ A}$		0.3	0.5	
$V_{BOOST}$	Output voltage	$V_{DD} = 12\text{ V}$	15.2	17		V
<b>UVLO</b>						
$V_{UVLO}$	Programmable UVLO threshold voltage	$R_{KFF} = 90.9\text{ k}\Omega$ , turn-on, $V_{VDD}$ rising	6.2	7.2	8.2	V
	Programmable UVLO hysteresis	$R_{KFF} = 90.9\text{ k}\Omega$	1.1	1.55	2	V
	Fixed UVLO threshold voltage	Turn-on, $V_{VDD}$ rising	4.15	4.3	4.45	V
	Fixed UVLO hysteresis		275	365		mV
<b>POWER GOOD</b>						
$V_{PG}$	Power-good voltage	$I_{PG} = 1\text{ mA}$		370	500	mV
$V_{OH}$	High-level output voltage, FB			770		mV
$V_{OL}$	Low-level output voltage, FB			630		mV
<b>THERMAL SHUTDOWN</b>						
	Shutdown temperature threshold <sup>(1)</sup>			165		$^{\circ}\text{C}$
	Hysteresis <sup>(1)</sup>			15		$^{\circ}\text{C}$

## 6.5 Typical Characteristics

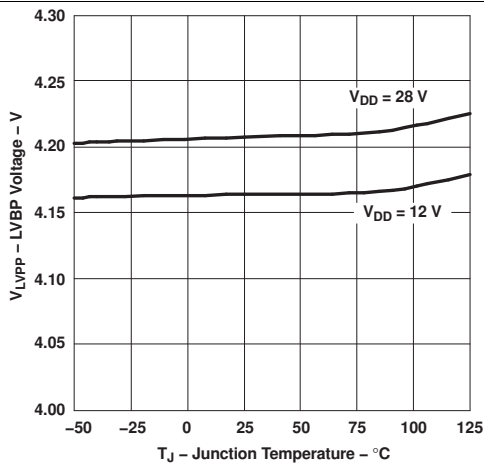

Figure 1. LVP Voltage vs Junction Temperature

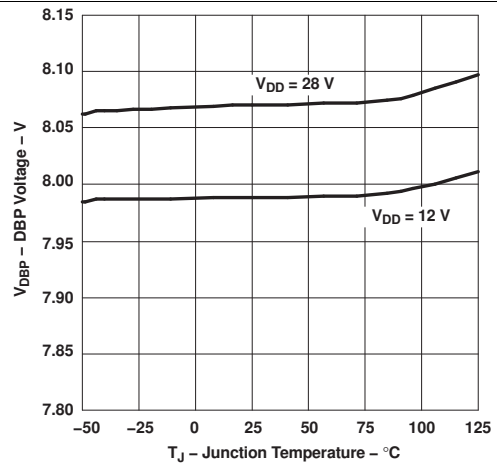

Figure 2. DBP Voltage vs Junction Temperature

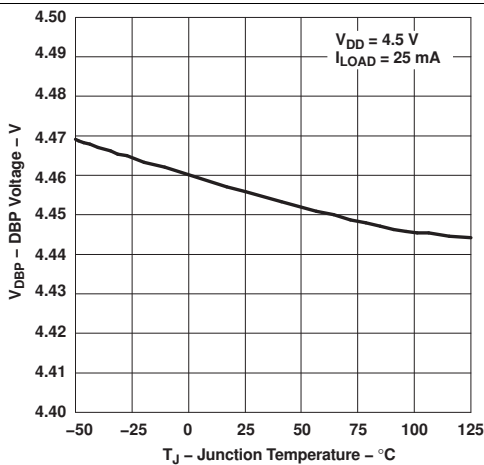

Figure 3. DBP Voltage vs Junction Temperature

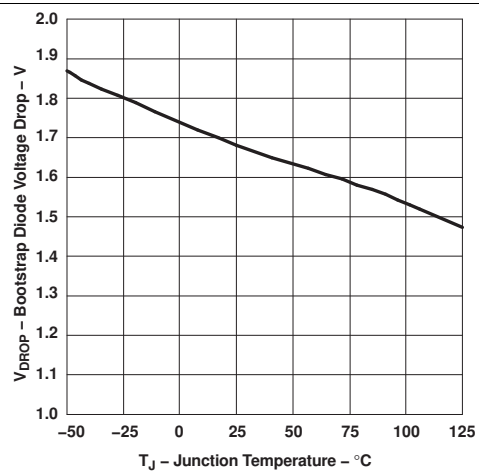

Figure 4. Bootstrap Diode Voltage vs Junction Temperature

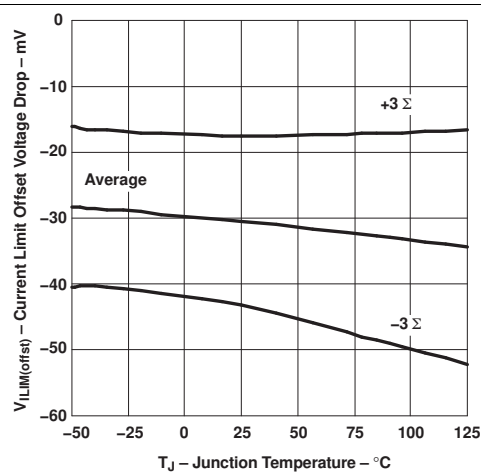

Figure 5. Current Limit Offset Voltage vs Junction Temperature

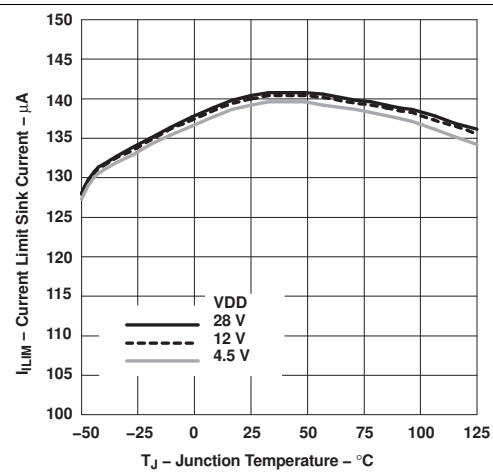
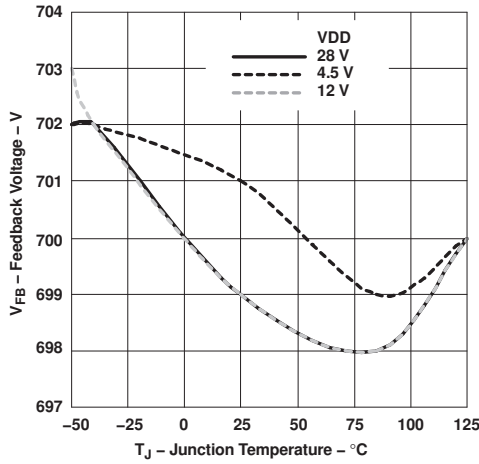

Figure 6. Current Limit Sink Current vs Junction Temperature



**Typical Characteristics (continued)**



**Figure 7. Feedback Regulation Voltage vs Junction Temperature**

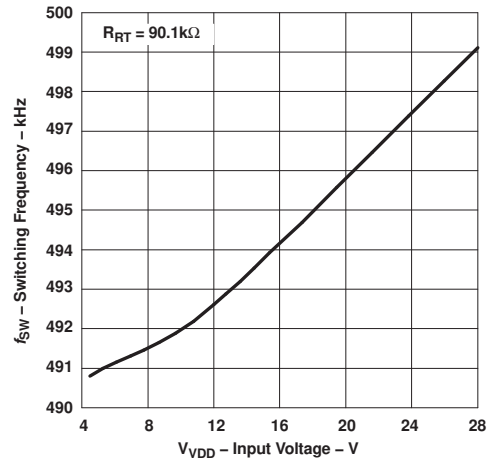

**Figure 8. Switching Frequency vs Input Voltage**

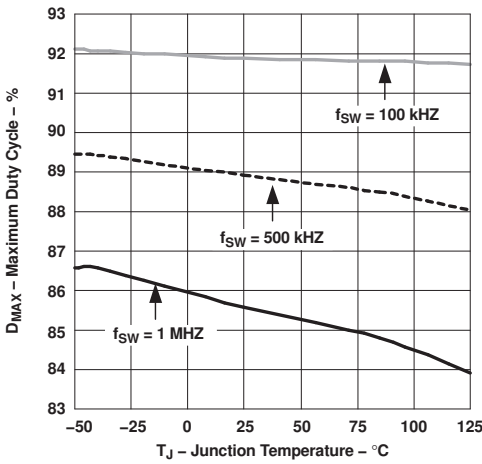

**Figure 9. Maximum Duty Cycle vs Junction Temperature**

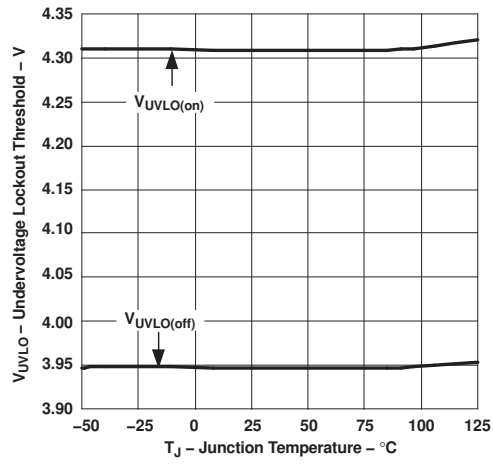

**Figure 10. Undervoltage Lockout vs Junction Temperature**

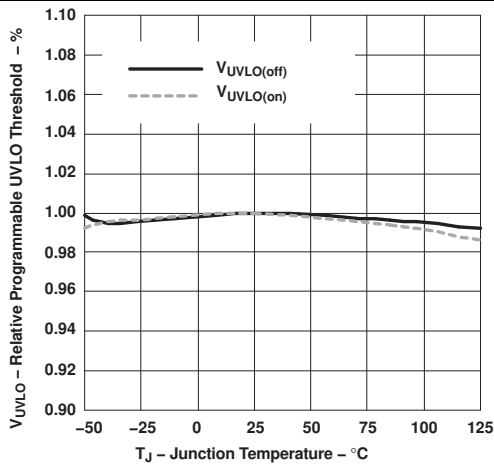

**Figure 11. Programmable UVLO Threshold vs Junction Temperature**

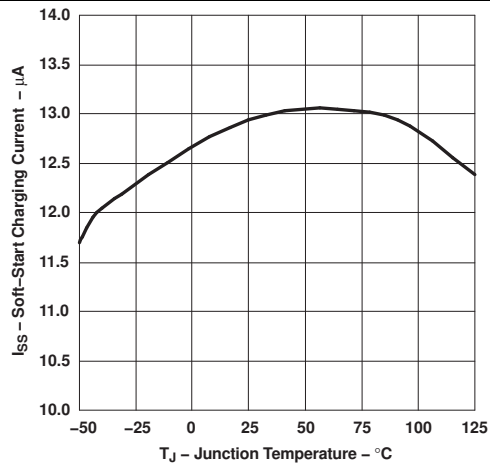

**Figure 12. Soft-Start Charging Current vs Junction Temperature**

Typical Characteristics (continued)

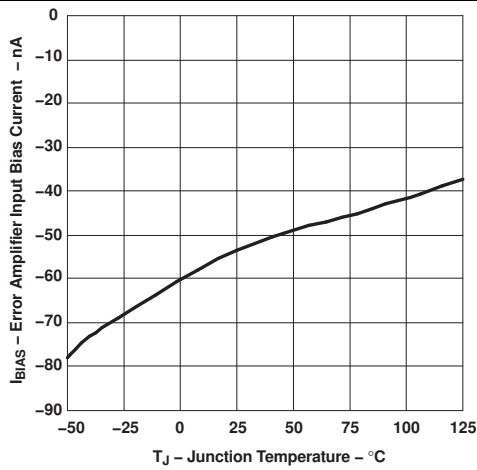

Figure 13. Error Amplifier Input Bias Current vs Junction Temperature

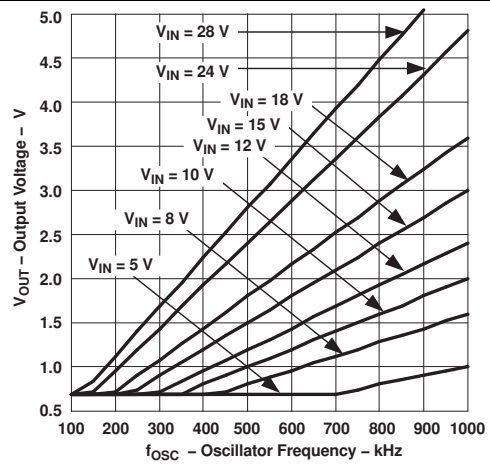

Figure 14. Minimum Output Voltage vs Frequency

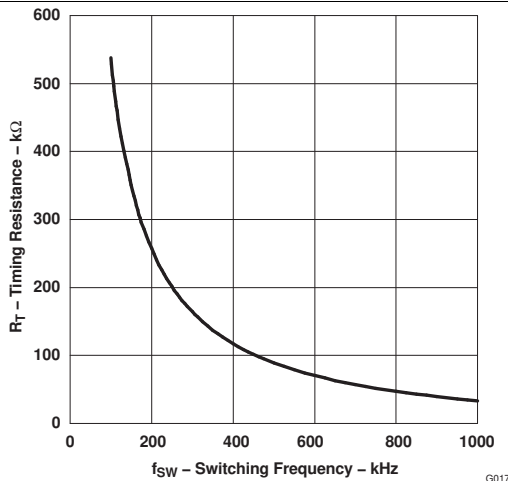

Figure 15. Switching Frequency vs Timing Resistance

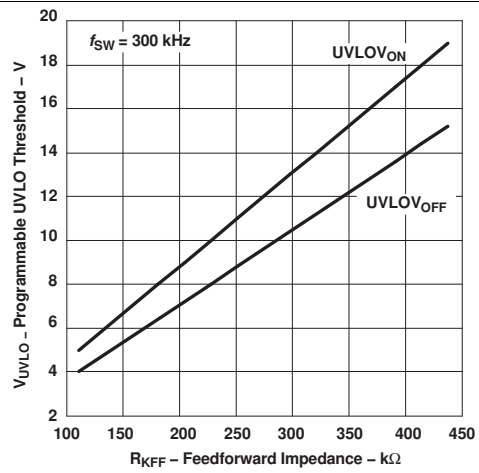

Figure 16. Undervoltage Lockout Threshold vs Feed-Forward Impedance

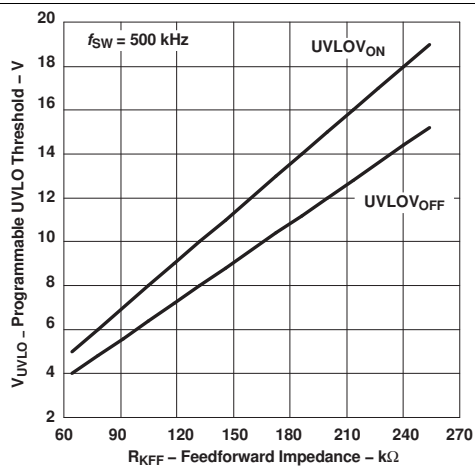

Figure 17. Undervoltage Lockout Threshold vs Feed-Forward Impedance

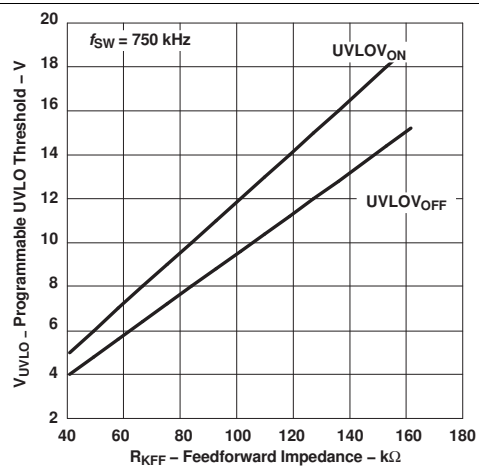

Figure 18. Undervoltage Lockout Threshold vs Feed-Forward Impedance

Typical Characteristics (continued)

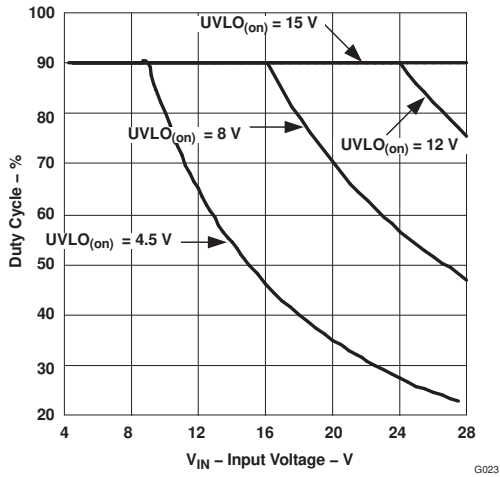

Figure 19. Typical Maximum Duty Cycle vs Input Voltage

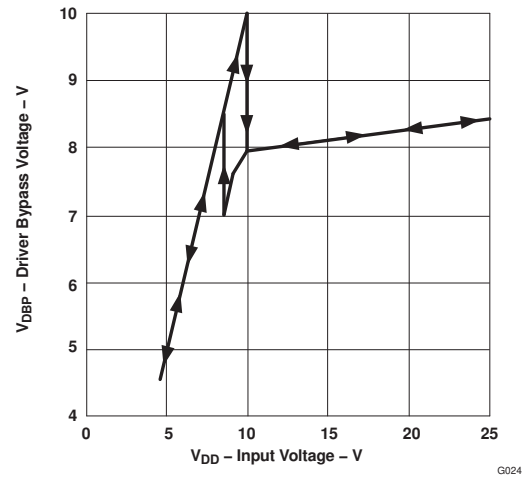

Figure 20. DBP Voltage vs Input Voltage

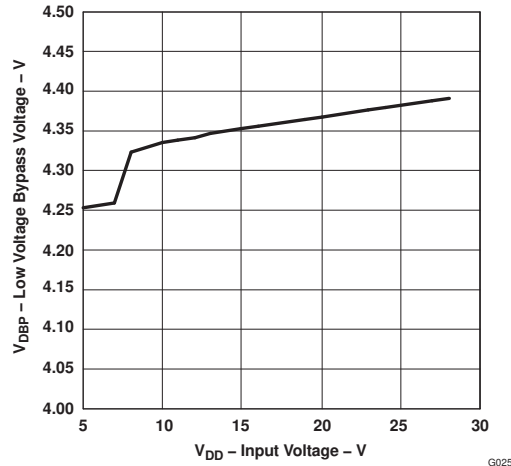

Figure 21. Input Voltage vs Low-Voltage Bypass Voltage

## 7 Detailed Description

### 7.1 Overview

The TPS40077 allows the user to construct synchronous voltage-mode buck converters with inputs ranging from 4.5 V to 28 V and outputs as low as 700 mV. Predictive Gate Drive circuitry optimizes switching delays for increased efficiency and improved converter output-power capability. Voltage feed forward is employed to ease loop compensation for wide-input-range designs and provide better line transient response.

The TPS40077 incorporates circuitry to allow start-up into a preexisting output voltage without sinking current from the source of the preexisting output voltage. This avoids damaging sensitive loads at start-up. An integrated power-good indicator is available for logic (open-drain) output of the condition of the output of the converter.

### 7.2 Functional Block Diagram

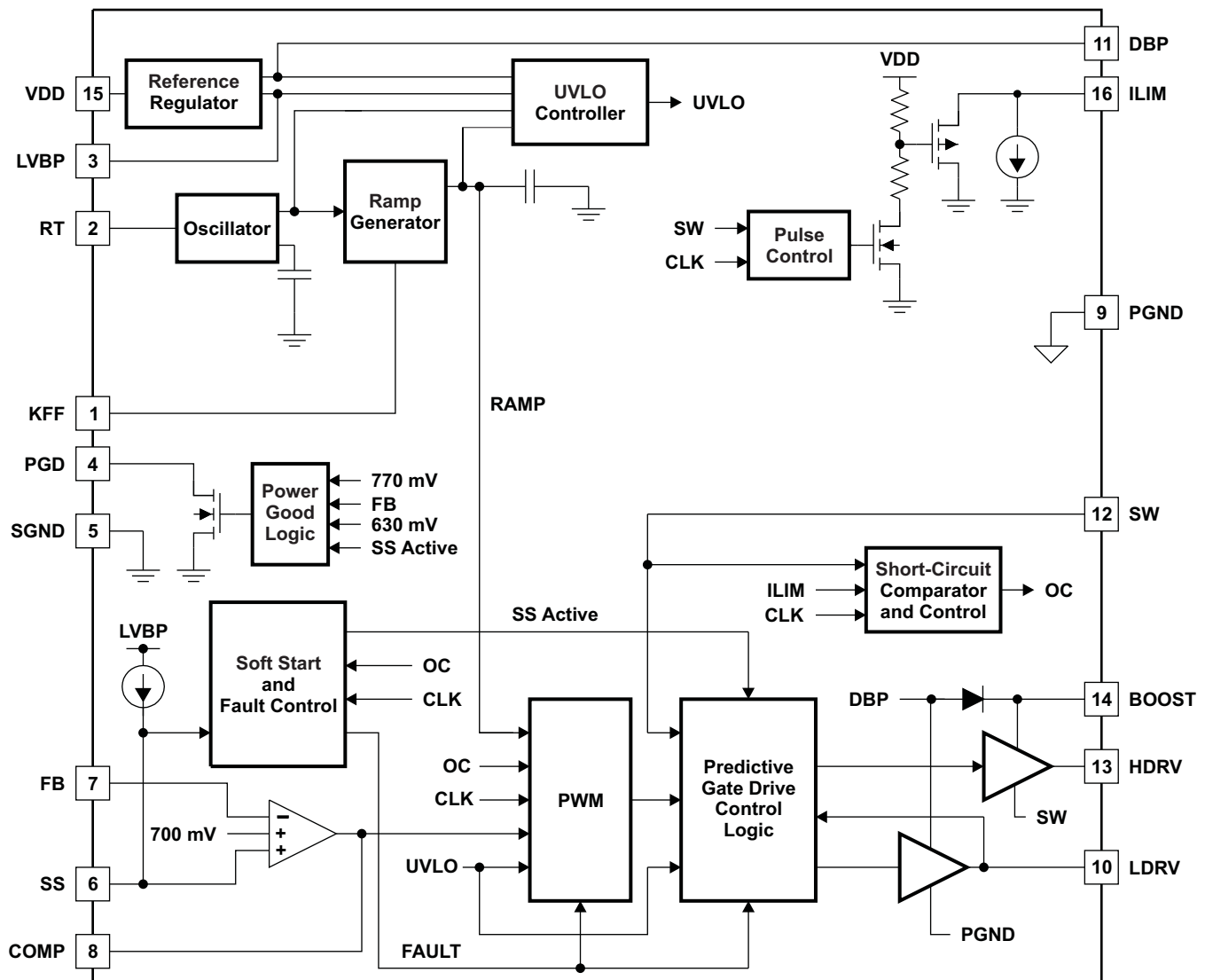

B0150-01

## 7.3 Feature Description

### 7.3.1 Minimum Pulse Duration

The TPS40077 devices have limitations on the minimum pulse duration that can be used to design a converter. Reliable operation is assured for nominal pulse durations of 150 ns and above. This places some restrictions on the conversion ratio that can be achieved at a given switching frequency. Figure 14 shows minimum output voltage for a given input voltage and frequency.

### 7.3.2 Slew Rate Limit On VDD

The regulator that supplies power for the drivers on the TPS40077 requires a limited rising slew rate on VDD for proper operation if the input voltage is above 10 V. If the slew rate is too great, this regulator can overshoot and damage to the part can occur. To ensure that the part operates properly, limit the slew rate to no more than 0.12 V/ $\mu$ s as the voltage at VDD crosses 8 V. If necessary, an R-C filter can be used on the VDD pin of the device. Connect the resistor from the VDD pin to the input supply of the converter. Connect the capacitor from the VDD pin to PGND. There should not be excessive (more than a 200-mV) voltage drop across the resistor in normal operation. This places some constraints on the R-C values that can be used. Figure 22 is a schematic fragment that shows the connection of the R-C slew rate limit circuit. Equation 1 and Equation 2 give values for R and C that limit the slew rate in the worst-case condition.

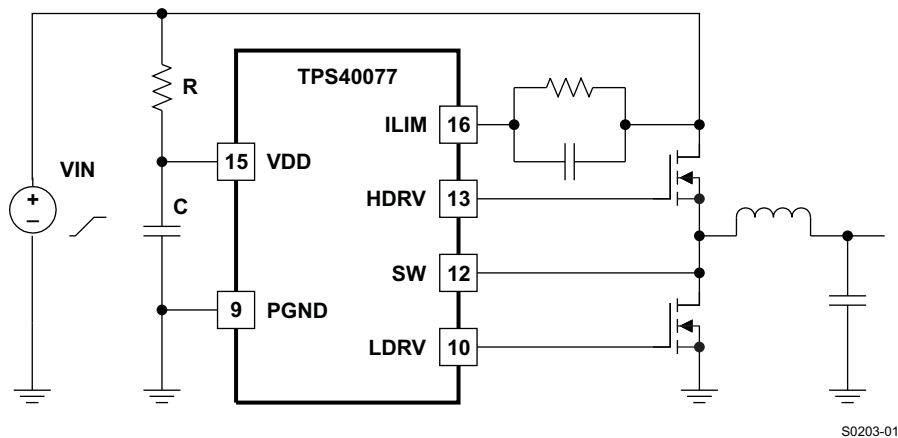

Figure 22. Limiting the Slew Rate

$$C > \frac{V_{IN} - 8 \text{ V}}{R \times \text{SR}} \quad (1)$$

$$R < \frac{0.2 \text{ V}}{f_{\text{SW}} \times Q_{\text{g(TOT)}} + I_{\text{DD}}}$$

where

- $V_{\text{IN}}$  is the final value of the input voltage ramp
- $f_{\text{SW}}$  is the switching frequency
- $Q_{\text{g(TOT)}}$  is the combined total gate charge for both upper and lower MOSFETs (from MOSFET data sheet)
- $I_{\text{DD}}$  is the TPS40077 input current (3.5 mA maximum)
- SR is the maximum allowed slew rate [ $12 \times 10^4$ ] (V/s) (2)

## Feature Description (continued)

### 7.3.3 Setting The Switching Frequency (Programming The Clock Oscillator)

The TPS40077 has independent clock oscillator and PWM ramp generator circuits. The clock oscillator serves as the master clock to the ramp generator circuit. Connecting a single resistor from RT to ground sets the switching frequency of the clock oscillator. The clock frequency is related to  $R_T$  with [Equation 3](#).

$$R_T = \left( \frac{1}{f_{SW}(\text{kHz}) \times 17.82 \times 10^{-6}} - 23 \right) \text{ k}\Omega \quad (3)$$

### 7.3.4 Loop Compensation

Voltage-mode, buck-type converters are typically compensated using Type III networks. Because the TPS40077 uses voltage feed-forward control, the gain of the voltage feed-forward circuit must be included in the PWM gain. The gain of the voltage feed-forward circuit, combined with the PWM circuit and power stage for the TPS40077 is [Equation 4](#).

$$K_{PWM} \cong V_{UVLO(on)} \quad (4)$$

The remainder of the loop compensation is performed as in a normal buck converter. Note that the voltage feed-forward circuitry removes the input voltage term from the expression for PWM gain. PWM gain is strictly a function of the programmed start-up voltage.

### 7.3.5 Shutdown and Sequencing

The TPS40077 can be shut down by pulling the SS pin below 250 mV. In this state, both of the output drivers are in the low-output state, turning off both of the power FETs. This places the output of the converter in a high-impedance state. When shutting down the converter, a crisp pulldown of the SS pin is preferred to a slow pulldown. A slow pulldown could allow the output to be pulled low, possibly sinking current from the load. As a general rule of thumb, the fall time of SS when shutting down the converter should be no more than 1/10th of the control loop crossover frequency. An example of a shutdown interface is shown in [Figure 23](#).

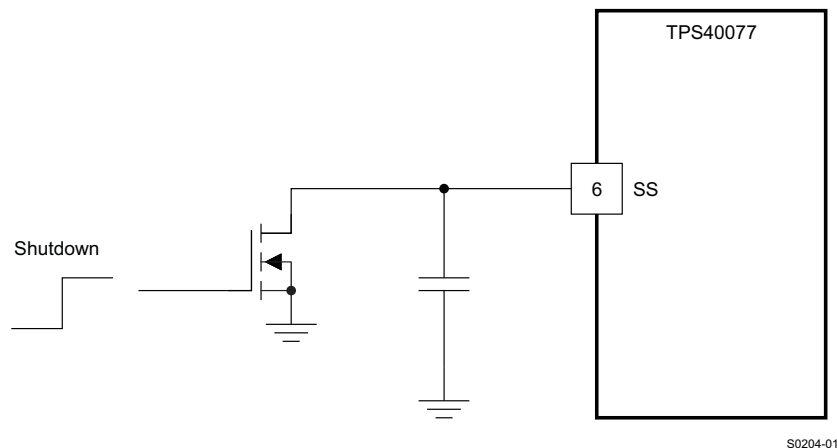

**Figure 23. TPS40077 Shutdown**

In a similar manner, power supplies based on the TPS40077 can be sequenced by connecting the PGD pin of the first supply to come up to the SS pin of the second supply as shown in [Figure 24](#).

## Feature Description (continued)

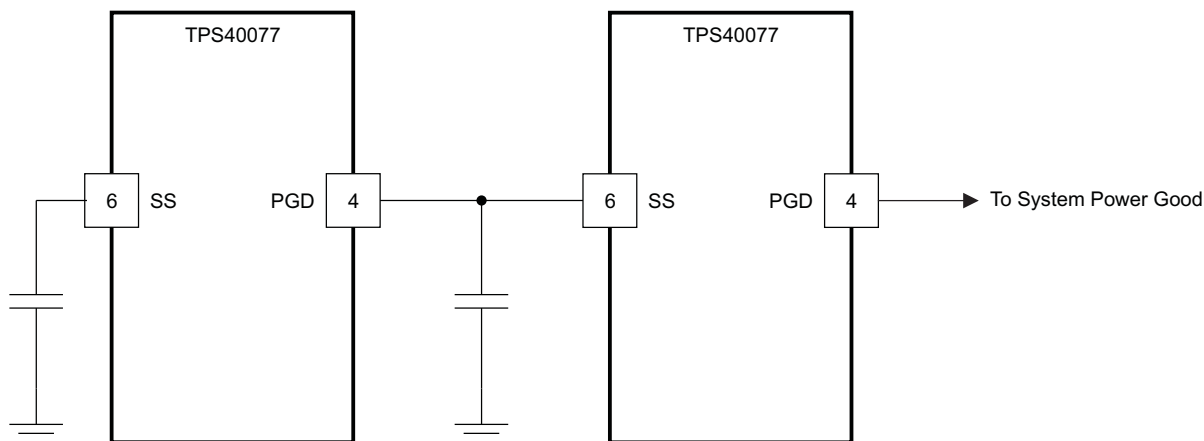

S0205-01

Figure 24. TPS40077 Sequencing

### 7.3.6 Boost and LVBP Bypass Capacitance

The BOOST capacitance provides a local, low-impedance flying source for the high-side driver. The BOOST capacitor should be a good-quality, high-frequency capacitor. A capacitor with a minimum value of 100-nF is suggested.

The LVBP pin must provide energy for both the synchronous MOSFET and the high-side MOSFET (via the BOOST capacitor). The suggested value for this capacitor is 1- $\mu$ F ceramic, minimum.

### 7.3.7 Internal Regulators

The internal regulators are linear regulators that provide controlled voltages from which the drivers and the internal circuitry operate. The DBP pin is connected to a nominal 8-V regulator that provides power for the driver circuits. This regulator has two modes of operation. At  $V_{DD}$  voltages below 8.5 V, the regulator is in a low-dropout mode of operation and tries to provide as little impedance as possible from  $V_{DD}$  to DBP. Above 10 V at  $V_{DD}$ , the regulator regulates DBP to 8 V. Between these two voltages, the regulator remains in the state it was in when  $V_{DD}$  entered this region (see Figure 20). Small amounts of current can be drawn from this pin for other circuit functions, as long as power dissipation in the controller device remains at acceptable levels and junction temperature does not exceed 125°C.

The LVBP pin is connected to another internal regulator that provides 4.2 V (nom) for the operation of low-voltage circuitry in the controller. This pin can be used for other circuit purposes, but extreme care must be taken to ensure that no extra noise is coupled onto this pin; otherwise, controller performance suffers. Current draw is not to exceed 1 mA. See Figure 21 for typical output voltage at this pin.

### 7.3.8 Power Dissipation

The power dissipation in the TPS40077 is largely dependent on the MOSFET driver currents and the input voltage. The driver current is proportional to the total gate charge,  $Q_g$ , of the external MOSFETs. Driver power (neglecting external gate resistance) can be calculated with Equation 5.

$$P_D = Q_g \times V_{DR} \times f_{SW} \quad (\text{Watts/driver})$$

where

$$V_{DR} \text{ is the driver output voltage} \quad (5)$$

The total power dissipation in the TPS40077, assuming the same MOSFET is selected for both the high-side and synchronous rectifier, is described in Equation 6 or Equation 7.

$$P_T = \left( \frac{2 \times P_D}{V_{DR}} + I_Q \right) \times V_{IN} \quad (\text{Watts}) \quad (6)$$

## Feature Description (continued)

or

$$P_T = (2 \times Q_g \times f_{SW} + I_Q) \times V_{IN} \quad (\text{Watts})$$

where  $I_Q$  is the quiescent operating current (neglecting drivers) (7)

The maximum power capability of the TPS40077 PowerPAD package is dependent on the layout as well as air flow. The thermal impedance from junction to air, assuming 2-oz. copper trace and thermal pad with solder and no air flow, is 37°C/W. See the application report titled *PowerPAD Thermally Enhanced Package (SLMA002)* for detailed information on PowerPAD package mounting and usage.

The maximum allowable package power dissipation is related to ambient temperature by [Equation 8](#). For  $\theta_{JA}$ , see [Table 1](#).

$$P_T = \frac{T_J - T_A}{\theta_{JA}} \quad (\text{Watts}) \quad (8)$$

**Table 1. Package Dissipation Ratings**

	THERMAL IMPEDANCE, JUNCTION-TO-AMBIENT <sup>(1)</sup>	T <sub>A</sub> = 25°C POWER RATING	T <sub>A</sub> = 85°C POWER RATING
Natural convection	37°C/W	2.7 W	1.08 W
150 LFM airflow	30°C/W	3.33 W	1.33 W
250 LFM airflow	28°C/W	3.57 W	1.42 W
500 LFM airflow	26°C/W	3.84 W	1.52 W

(1) For more information on the board and the methods used to determine ratings, see the *PowerPAD Thermally Enhanced Package* application report ([SLMA002](#)).

Substituting [Equation 8](#) into [Equation 7](#) and solving for  $f_{SW}$  yields the maximum operating frequency for the TPS40077. The result is described in [Equation 9](#).

$$f_{SW} = \frac{\left( \left[ \frac{(T_J - T_A)}{(\theta_{JA} \times V_{DD})} \right] - I_Q \right)}{(2 \times Q_g)} \quad (\text{Hz}) \quad (9)$$

### 7.3.9 Boost Diode

The TPS40077 series has internal diodes to charge the boost capacitor connected from SW to BOOST. The drop across these diodes is rather large, 1.4 V nominal, at room temperature. If this drop is too large for a particular application, an external diode may be connected from DBP (anode) to BOOST (cathode). This provides significantly improved gate drive for the high-side FET, especially at lower input voltages.

### 7.3.10 Synchronous Rectifier Control

[Table 2](#) describes the state of the rectifier MOSFET control under various operating conditions.

**Table 2. Synchronous Rectifier MOSFET States**

SYNCHRONOUS RECTIFIER OPERATION DURING			
SOFT-START	NORMAL	FAULT (FAULT RECOVERY IS SAME AS SOFT-START)	OVERVOLTAGE
Off until first high-side pulse is detected, then on when high-side MOSFET is off	Turns off at the start of a new cycle. Turns on when the high-side MOSFET is turned off	OFF	Turns OFF only at start of next cycle only if the pulse width modulator duty cycle is greater than zero. Otherwise, stays ON



For proper operation, the total gate charge of the MOSFET connected to LDRV must be less than 50 nC.

## 7.4 Programming

### 7.4.1 Programming The Ramp Generator Circuit and UVLO

The ramp generator circuit provides the actual ramp used by the PWM comparator. The ramp generator provides voltage feed-forward control by varying the PWM ramp slope with line voltage, while maintaining a constant ramp magnitude. Varying the PWM ramp directly with line voltage provides excellent response to line variations, because the PWM is not required to wait for loop delays before changing the duty cycle. (See [Figure 25](#)).

The PWM ramp must reach approximately 1 V in amplitude during a clock cycle, or the PWM is not allowed to start. The PWM ramp time is programmed via a single resistor ( $R_{KFF}$ ) connected from KFF VDD.  $R_{KFF}$ ,  $V_{START}$ , and  $R_T$  are related by (approximately) [Equation 10](#).

$$R_{KFF} = 0.131 \times R_T \times V_{UVLO(on)} - 1.61 \times 10^{-3} \times V_{UVLO(on)}^2 + 1.886 \times V_{UVLO} - 1.363 - 0.02 \times R_T - 4.87 \times 10^{-5} \times R_T^2$$

where

- $R_T$  and  $R_{KFF}$  are in  $k\Omega$
  - $V_{UVLO(on)}$  is in V
- (10)

This yields typical numbers for the programmed start-up voltage. The minimum and maximum values may vary up to  $\pm 15\%$  from this number. [Figure 16](#) through [Figure 18](#) show the typical relationship of  $V_{UVLO(on)}$ ,  $V_{UVLO(off)}$  and  $R_{KFF}$  at three common frequencies.

The programmable UVLO circuit incorporates 20% hysteresis from the start voltage to the shutdown voltage. For example, if the start-up voltage is programmed to be 10 V, the controller starts when  $V_{DD}$  reaches 10 V and shuts down when  $V_{DD}$  falls below 8 V. The maximum duty cycle begins to decrease as the input voltage rises to twice the start-up voltage. Below this point, the maximum duty cycle is as specified in the [Electrical Characteristics](#). Note that with this scheme, the theoretical maximum output voltage that the converter can produce is approximately two times the programmed start-up voltage. For design, set the programmed start-up voltage equal to or greater than the desired output voltage divided by maximum duty cycle (85% for frequencies 500 kHz and below). For example, a 5-V output converter should not have a programmed start-up voltage below 5.9 V. [Figure 25](#) shows the theoretical maximum duty cycle (typical) for various programmed start-up voltages.

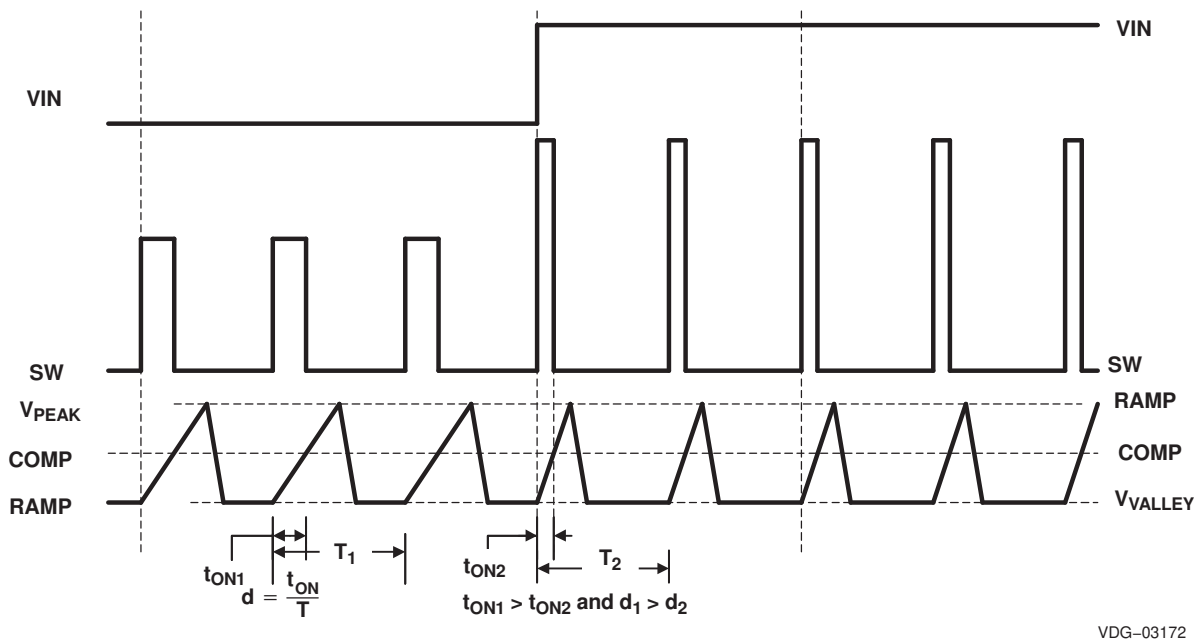

Figure 25. Voltage Feed-Forward and PWM Duty Cycle Waveforms

## Programming (continued)

### 7.4.2 Programming Soft Start

TPS40077 uses a closed-loop approach to ensure a controlled ramp on the output during start-up. Soft start is programmed by connecting an external capacitor ( $C_{SS}$ ) from the SS pin to GND. This capacitor is charged by a fixed current, generating a ramp signal. The voltage on SS is level-shifted down approximately 1 V and fed into a separate noninverting input to the error amplifier. The loop is closed on the lower of the level-shifted SS voltage or the 700-mV internal reference voltage. Once the level-shifted SS voltage rises above the internal reference voltage, output-voltage regulation is based on the internal reference. To ensure a controlled ramp-up of the output voltage, the soft-start time should be greater than the  $L-C_{OUT}$  time constant or [Equation 11](#).

$$t_{START} \geq 2\pi \times \sqrt{L \times C_{OUT}} \quad (11)$$

Note that there is a direct correlation between  $t_{START}$  and the input current required during start-up. The lower  $t_{START}$  is, the higher the input current required during start-up, because the output capacitance must be charged faster. For a desired soft-start time, the soft-start capacitance,  $C_{SS}$ , can be found from [Equation 12](#).

$$C_{SS} = t_{SS} \times \frac{I_{SS}}{V_{FB}} \quad (12)$$

### 7.4.3 Programming Short-Circuit Protection

The TPS40077 uses a two-tier approach for short-circuit protection. The first tier is a pulse-by-pulse protection scheme. Short-circuit protection is implemented on the high-side MOSFET by sensing the voltage drop across the MOSFET when its gate is driven high. The MOSFET voltage is compared to the voltage dropped across a resistor ( $R_{ILIM}$ ) connected from  $V_{VDD}$  to the ILIM pin when driven by a constant-current sink. If the voltage drop across the MOSFET exceeds the voltage drop across the ILIM resistor, the switching pulse is immediately terminated. The MOSFET remains off until the next switching cycle is initiated. This is illustrated in [Figure 26](#).

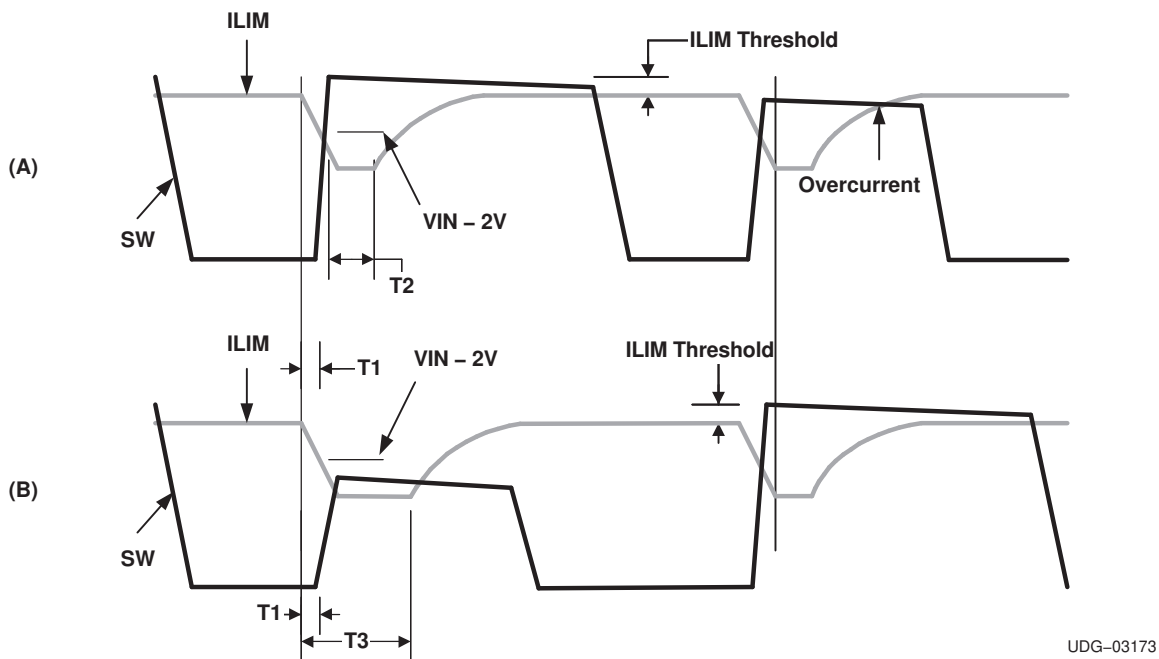

**Figure 26. Switching and Current-Limit Waveforms and Timing Relationship**

## Programming (continued)

In addition, just prior to the high-side MOSFET turning on, the ILIM pin is pulled down to approximately half of  $V_{VDD}$ . The ILIM pin is allowed to return to its nominal value after one of two events occurs. If the SW node rises to within approximately 2 V of  $V_{VDD}$ , the device allows ILIM to go back to its nominal value. This is illustrated in Figure 26(A). T1 is the delay time from the internal PWM signal being asserted and the rise of SW. This includes a driver delay of 50 ns, typical. T2 is the reaction time of the sensing circuit that allows ILIM to start to return to its nominal value, typically 20 ns. The second event that can cause ILIM to return to its nominal value is for an internal timeout to expire. This is illustrated in Figure 26(B) as T3. Here SW never rises to  $V_{VDD} - 2$  V, for whatever reason, and the internal timer times out, releasing the ILIM pin.

Prior to ILIM starting back to its nominal value, overcurrent sensing is not enabled. In normal operation, this ensures that the SW node is at a higher voltage than ILIM when overcurrent sensing starts, avoiding false trips while allowing for a quicker blanking delay than would ordinarily be possible. Placing a capacitor across  $R_{ILIM}$  sets an exponential approach to the normal voltage at the ILIM pin. This exponential decay of the overcurrent threshold can be used to compensate for ringing on the SW node after its rising edge and to help compensate for slower-turnon FETs. Choosing the proper capacitance requires care. If the capacitance is too large, the voltage at ILIM does not approach the desired overcurrent level quickly enough, resulting in an apparent shift in overcurrent threshold as pulse duration changes. As a general rule, it is best to make the time constant of the R-C at the ILIM pin 0.2 times or less of the nominal pulse duration of the converter as shown in Equation 17.

Also, the comparator that uses ILIM and SW to determine if an overcurrent condition exists has a clamp on its SW input. This clamp makes the SW node never appear to fall more than 1.4 V (approximately, could be as much as 2 V at  $-40^{\circ}\text{C}$ ) below  $V_{VDD}$ . When ILIM is more than 1.4 V below  $V_{VDD}$ , the overcurrent circuit is effectively disabled.

The second-tier protection incorporates a fault counter. The fault counter is incremented on each cycle with an overcurrent pulse and decremented on a clock cycle without an overcurrent pulse. When the counter reaches seven (7), a fault condition is declared by the controller. When this happens, the outputs are placed in a state defined in Table 2. Seven soft-start cycles are initiated (without activity on the HDRV and LDRV outputs) and the PWM is disabled during this period. The counter is decremented on each soft-start cycle. When the counter is decremented to zero, the PWM is re-enabled and the controller attempts to restart. If the fault has been removed, the output starts up normally. If the output is still present, the counter counts seven overcurrent pulses and re-enters the second-tier fault mode. Refer to Figure 27 for typical fault-protection waveforms.

In Equation 13, the minimum short-circuit limit setpoint ( $I_{SCP(\min)}$ ) depends on  $t_{\text{START}}$ ,  $C_{\text{OUT}}$ ,  $V_{\text{OUT}}$ , ripple current in the inductor ( $I_{\text{RIPPLE}}$ ), and the load current at turnon ( $I_{\text{LOAD}}$ ).

$$I_{SCP(\min)} > \left( \frac{C_{\text{OUT}} \times V_{\text{OUT}}}{t_{\text{START}}} \right) + I_{\text{LOAD}} + \left( \frac{I_{\text{RIPPLE}}}{2} \right) \quad (13)$$

The short-circuit limit programming resistor ( $R_{ILIM}$ ) is calculated from Equation 14.

$$R_{ILIM} = \frac{I_{SCP} \times R_{DS(\text{onMAX})} + V_{ILIM(\text{offset})}}{I_{ILIM}} \quad \Omega$$

where

- $I_{ILIM}$  is the current into the ILIM pin (110  $\mu\text{A}$ , typical)
  - $V_{ILIM(\text{offset})}$  is the offset voltage of the ILIM comparator ( $-50$  mV, typical)
  - $I_{SCP}$  is the short-circuit protection current
- (14)

To find the range of the overcurrent values, use Equation 15 and Equation 16.

$$I_{SCP(\max)} = \frac{1.09 \times I_{ILIM(\max)} \times R_{ILIM} - 0.09 \times R_{VDD} \times I_{R_{VDD}} - 0.045 \text{ V} + 75 \text{ mV}}{R_{DS(\text{ON})\min}} \quad (\text{A}) \quad (15)$$

$$I_{SCP(\min)} = \frac{1.09 \times I_{ILIM(\min)} \times R_{ILIM} - 0.09 \times R_{VDD} \times I_{R_{VDD}} - 0.045 \text{ V} + 30 \text{ mV}}{R_{DS(\text{ON})\max}} \quad (\text{A}) \quad (16)$$

## Programming (continued)

The TPS40077 provides short-circuit protection only. Therefore, it is recommended that the minimum short-circuit protection level be placed at least 20% above the maximum output current required from the converter. The maximum output of the converter should be the steady state maximum output plus any transient specification that may exist.

The ILIM capacitor maximum value can be found from [Equation 17](#).

$$C_{ILIM(max)} = \frac{V_{OUT} \times 0.2}{V_{IN} \times R_{ILIM} \times f_{SW}} \text{ (Farads)} \quad (17)$$

Note that this is a recommended maximum value. If a smaller value can be used, it should be. For most applications, consider using half the maximum value above.

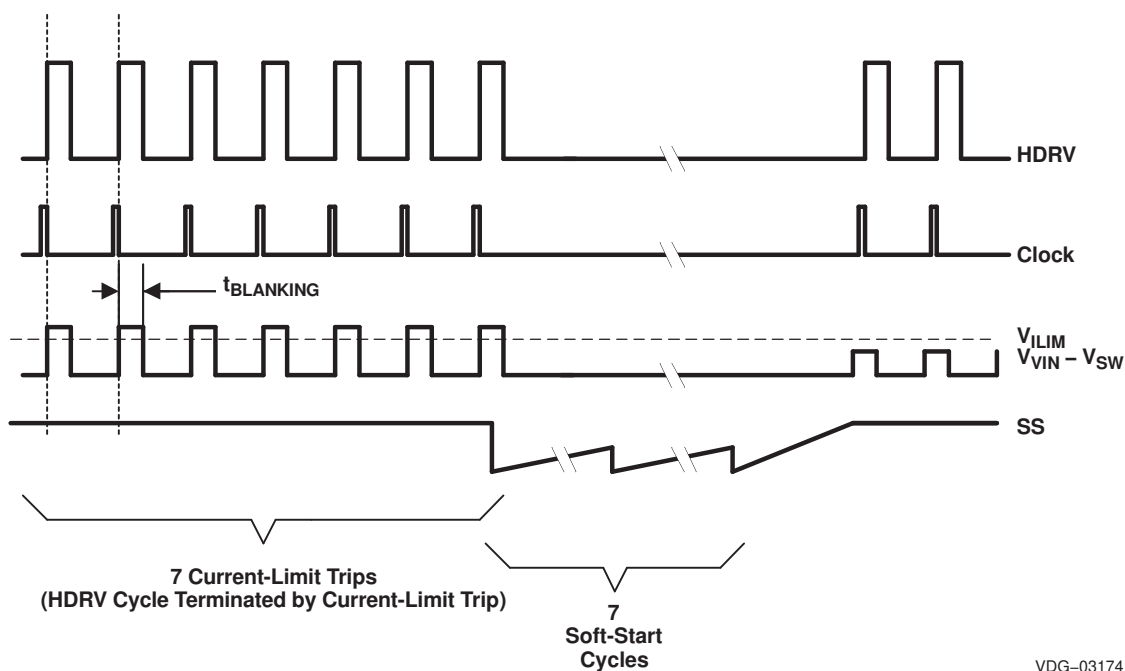

**Figure 27. Typical Fault Protection Waveforms**

## 8 Application and Implementation

### NOTE

Information in the following applications sections is not part of the TI component specification, and TI does not warrant its accuracy or completeness. TI's customers are responsible for determining suitability of components for their purposes. Customers should validate and test their design implementation to confirm system functionality.

### 8.1 Application Information

The TPS40077 allows the user to construct synchronous voltage-mode buck converters with inputs ranging from 4.5 V to 28 V and outputs as low as 700 mV. Predictive Gate Drive circuitry optimizes switching delays for increased efficiency and improved converter output-power capability. Voltage feed-forward is employed to ease loop compensation for wide-input-range designs and provide better line transient response.

The TPS40077 incorporates circuitry to allow startup into a preexisting output voltage without sinking current from the source of the preexisting output voltage. This avoids damaging sensitive loads at start-up. An integrated power-good indicator is available for logic (open-drain) output of the condition of the output of the converter.

### 8.2 Typical Applications

#### 8.2.1 Buck Regulator 8-V to 16-V Input, 1.8-V Output at 10 A

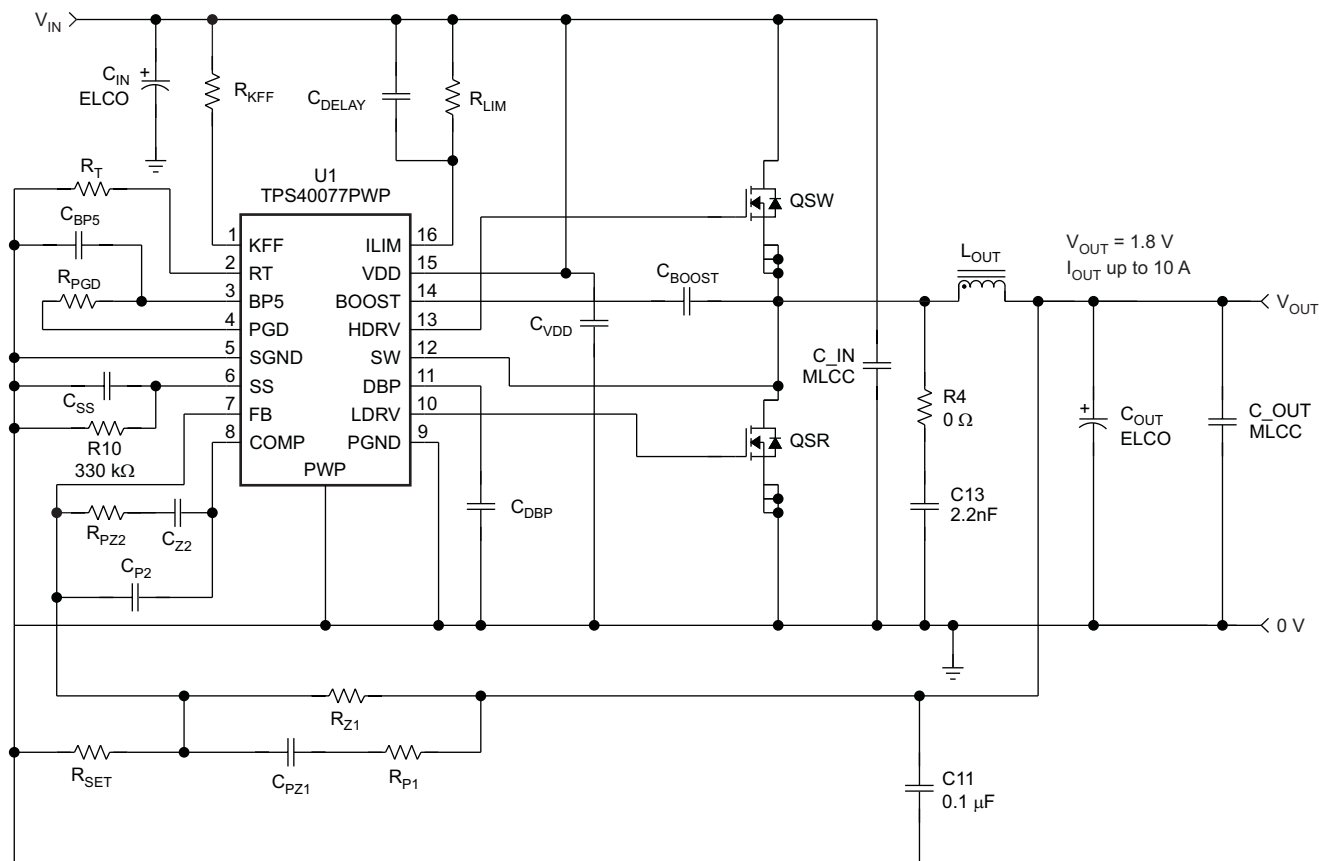

S0239-01

Figure 28. Schematic Diagram

#### 8.2.1.1 Design Requirements

Table 3 lists the design specifications and Table 4 lists the bill of materials for this buck regulator application example.

Typical Applications (continued)

Table 3. Characteristics

PARAMETER	NOTES AND CONDITIONS	MIN	NOM	MAX	UNITS		
<b>INPUT CHARACTERISTICS</b>							
V <sub>IN</sub>	Input voltage	8	12	16	V		
I <sub>IN</sub>	Input current	V <sub>IN</sub> = NOM, I <sub>OUT</sub> = MAX		1.8	2	A	
	No-load input current	V <sub>IN</sub> = NOM, I <sub>OUT</sub> = 0 A		62.6	3.6	mA	
V <sub>IN_UVLO</sub>	Input UVLO	I <sub>OUT</sub> = MIN to MAX		5.4	6	6.6	V
V <sub>IN_ONV</sub>	Input ONV	I <sub>OUT</sub> = MIN to MAX		6.3	7	7.7	V
<b>OUTPUT CHARACTERISTICS</b>							
V <sub>OUT</sub>	Output voltage	V <sub>IN</sub> = NOM, I <sub>OUT</sub> = NOM		1.75	1.8	1.85	V
	Line regulation <sup>(1)</sup>	V <sub>IN</sub> = MIN to MAX, I <sub>OUT</sub> = NOM			0.5%		
	Load regulation <sup>(1)</sup>	V <sub>IN</sub> = NOM, I <sub>OUT</sub> = MIN to MAX			0.5%		
V <sub>OUT_ripple</sub>	Output voltage ripple	V <sub>IN</sub> = NOM, I <sub>OUT</sub> = MAX			100		mVpp
I <sub>OUT</sub>	Output current	V <sub>IN</sub> = MIN to MAX		0	5	10	A
I <sub>OC</sub>	Output overcurrent inception point	V <sub>IN</sub> = NOM, V <sub>OUT</sub> = V <sub>OUT</sub> – 5%		12.25	19.4	34	A
V <sub>OVP</sub>	Output OVP	I <sub>OUT</sub> = MIN to MAX		NA	NA	NA	
<b>Transient response</b>							
ΔI	Load step	I <sub>OUT_Max</sub> to 0.2 × I <sub>OUT_Max</sub>			8		A
	Load slew rate				10		A/μs
	Overshoot				200		mV
	Settling time				1		ms
<b>SYSTEM CHARACTERISTICS</b>							
f <sub>SW</sub>	Switching frequency	240	300	360			kHz
η <sub>pk</sub>	Peak efficiency	V <sub>IN</sub> = NOM, I <sub>OUT</sub> = MIN to MAX			90%		
η	Full-load efficiency	V <sub>IN</sub> = NOM, I <sub>OUT</sub> = MAX			90%		
T <sub>op</sub>	Operating temperature range	–40	25	85			°C
<b>MECHANICAL CHARACTERISTICS</b>							
L	Width			2			Inches
				5.08			cm
W	Length			3			Inches
				7.62			cm
h	Component height			0.41			Inch
				1.04			cm

(1) Voltage accuracy is dependent on resistor tolerance and reference accuracy. Line and load regulation are calculated with respect to the actual set point voltage.

Table 4. Bill of Materials

REFDES	COUNT	VALUE	DESCRIPTION	SIZE	PART NUMBER	MFR
C1	1	470 μF	Capacitor, aluminum, 470-μF, 25-V, 20%	0.457 x 0.406	EEVFK1E471P	Panasonic
C2, C10	2	0.1 μF	Capacitor, ceramic, 25-V, X7R, 20%	0603	Std	Vishay
C3	1	15 nF	Capacitor, ceramic, 25-V, X7R 20%	0603	Std	Vishay
C4	1	47 pF	Capacitor, ceramic, 25-V, X7R, 20%	0603	Std	Vishay
C5	1	1.8 nF	Capacitor, ceramic, 25-V, X7R 20%	0603	Std	Vishay
C6	1	680 pF	Capacitor, ceramic, 25-V, X7R 20%	0603	Std	Vishay
C7	1	51 pF	Capacitor, ceramic, 25-V, COG 20%	0603	Std	Vishay
C8, C11	2	0.1 μF	Capacitor, ceramic, 25-V, X7R, 20%	0603	Std	Vishay

**Table 4. Bill of Materials (continued)**

REFDES	COUNT	VALUE	DESCRIPTION	SIZE	PART NUMBER	MFR
C9	1	1 $\mu$ F	Capacitor, ceramic, 25-V, X7R, 20%	0805	Std	Vishay
C12, C14, C15	3	22 $\mu$ F	Capacitor, ceramic, 22- $\mu$ F, 16-V, X5R, 20%	1812	C4532X5R1C226MT	TDK
C13	1	2.2 nF	Capacitor, ceramic, 25-V, X7R, 20%	0603	Std	Vishay
C16	1	470 $\mu$ F	Capacitor, aluminum, SM, 6.3-V, 300-m $\Omega$ (FC series)	8 x 10	Std	Panasonic
C17	1	47 $\mu$ F	Capacitor, ceramic, 47-uF, 6.3-V, X5R, 20%	1812	C4532X5R0J476MT	TDK
D1	1	BAT54	Diode, Schottky, 200-mA, 30-V	SOT23	BAT54	Vishay
J1, J2	2	ED1609-ND	Terminal block, 2-pin, 15-A, 5,1-mm	0.40 x 0.35	ED1609	OST
J3	1	PTC36SAAN	Header, 2-pin, 100-mil spacing, (36-pin strip)	0.100 x 2	PTC36SAAN	Sullins
L1	1	2.5 $\mu$ H	Inductor, SMT, 2.5 $\mu$ H, 16.5-A, 3.4-m $\Omega$	0.515 x 0.516	MLC1550-252ML	Coilcraft
Q1	1	Si7860DP	MOSFET, N-channel, 30-V, 18-A, 8.0-m $\Omega$	PWRPAK S0-8	Si7860DP	Vishay
Q2	1	Si7336ADP	MOSFET, N-channel, 30-V, 18-A, 40-m $\Omega$	PWRPAK S0-8	Si7886ADP	Vishay
Q3	1	FDV301N	MOSFET, N-channel, 25-V, 220-mA, 5- $\Omega$	SOT23	FDV301N	Fairchild
R1	1	10 k $\Omega$	Resistor, chip, 1/16-W, 20%	0603	Std	Std
R2, R6	2	165 k $\Omega$	Resistor, Chip, 1/16-W, 20%	0603	Std	Std
R3	1	32.4 k $\Omega$	Resistor, chip, 1/16-W, 20%	0603	Std	Std
R4, R11	2	0 $\Omega$	Resistor, chip, 1/16-W, 20%	0603	Std	Std
R5	1	21.5 k $\Omega$	Resistor, chip, 1/16-W, 20%	0603	Std	Std
R7	1	51 k $\Omega$	Resistor, chip, 1/16-W, 20%	0603	Std	Std
R8	1	3.3 k $\Omega$	Resistor, chip, 1/16-W, 20%	0603	Std	Std
R9	1	1.8 k $\Omega$	Resistor, chip, 1/16-W, 20%	0603	Std	Std
R10	1	330 k $\Omega$	Resistor, chip, 1/16-W, 20%	0603	Std	Std
R12	1	51 $\Omega$	Resistor, chip, 1/16-W, 20%	0603	Std	Std
R13	1	1 k $\Omega$	Resistor, chip, 1/16-W, 20%	0603	Std	Std
U1	1	TPS40077PWP	IC, Texas Instruments	PWP16	TPS40077PWP	TI

### 8.2.1.2 Detailed Design Procedure

#### 8.2.1.2.1 Power Train Components

##### 8.2.1.2.1.1 Output Inductor, L<sub>OUT</sub>

The output inductor is one of the most important components to select. It stores the energy necessary to keep the output regulated when the switch FET is turned off. The value of the output inductor dictates the peak and RMS currents in the converter. These currents are important when selecting other components. Equation 18 can be used to calculate a value for L<sub>OUT</sub> for this module which operates at a switching frequency (f) of 300 kHz.

$$L_{OUT} = \frac{V_{OUT}}{V_{IN(max)}} \times \frac{V_{IN(max)} - V_{OUT}}{f_s \times I_{RIPPLE}} \quad (18)$$

I<sub>RIPPLE</sub> is the allowable ripple in the inductor. Select I<sub>RIPPLE</sub> to be between 20% and 30% of maximum I<sub>OUT</sub>. For this design, I<sub>RIPPLE</sub> of 2.5 A was selected. Calculated L<sub>OUT</sub> is 2.13  $\mu$ H. A standard inductor with value of 2.5  $\mu$ H was chosen. This will reduce I<sub>RIPPLE</sub> by about 17% to 2.07 A.

This I<sub>RIPPLE</sub> value can be used calculate the rms and peak current flowing in L<sub>OUT</sub> with Equation 19. Note that this peak current is also seen by the switching FET and synchronous rectifier.

$$I_{\text{LOUT\_RMS}} = \sqrt{I_{\text{OUT}}^2 + \frac{I_{\text{RIPPLE}}^2}{12}} = 10.02 \text{ A} \quad (19)$$

The power loss from the selected inductor DCR is 357 mW. The ac core loss for this Coilcraft inductor may be found from the Coilcraft Web site, where there is a [loss calculator](#). The loss is 179 mW calculated with [Equation 20](#).

$$I_{\text{PK}} = I_{\text{OUT}} + \frac{I_{\text{RIPPLE}}}{2} = 11.03 \text{ A} \quad (20)$$

The inductor is selected with a saturation current higher than this current plus the current that is developed charging the output capacitance during the soft-start interval.

### 8.2.1.2.1.2 Output Capacitor, COUT, ELCO and MLCC

Several parameters must be considered when selecting the output capacitor. The capacitance value should be selected based on the output overshoot,  $V_{\text{OVER}}$ , and undershoot,  $V_{\text{UNDER}}$ , during a transient load,  $I_{\text{STEP}}$ , on the converter. The equivalent series resistance (ESR) is chosen to allow the converter to meet the output ripple specification,  $V_{\text{RIPPLE}}$ . The voltage rating must be greater than the maximum output voltage. Another parameter to consider is equivalent series inductance, which is important in fast-transient load situations. Also, size and technology can be factors when choosing the output capacitor. In this design, a large-capacitance electrolytic type capacitor, COUT ELCO, is used to meet the overshoot and undershoot specifications. Its ESR is chosen to meet the output ripple specification. Smaller multiple-layer ceramic capacitors, COUT MLCC, are used to filter high-frequency noise.

The minimum required capacitance and maximum ESR can be calculated using [Equation 21](#), [Equation 22](#), and [Equation 23](#).

$$C_{\text{OUT}} = \frac{L_{\text{OUT}} \times I_{\text{STEP}}^2}{2 \times V_{\text{UNDER}} \times D_{\text{max}} \times (V_{\text{IN}} - V_{\text{OUT}})} \quad (21)$$

$$C_{\text{OUT}} = \frac{L_{\text{OUT}} \times I_{\text{STEP}}^2}{2 \times V_{\text{OVER}} \times V_{\text{OUT}}} \quad (22)$$

$$\text{ESR} = \frac{V_{\text{RIPPLE}}}{I_{\text{RIPPLE}}} \quad (23)$$

The capacitance for COUT should be greater than 444  $\mu\text{F}$ , and its ESR should be less than 12 m $\Omega$ . The 470- $\mu\text{F}/6.3\text{-V}$  capacitor from Panasonic's FC series was chosen. Its ESR is 160 m $\Omega$ . MLCCs of 47  $\mu\text{F}$  and 22  $\mu\text{F}/16 \text{ V}$  are also added in parallel to achieve the required ESR and to reduce high-frequency noise.

### 8.2.1.2.1.3 Input Capacitor, CIN ELCO and MLCC

The input capacitor is selected to handle the ripple current of the buck stage. Also, a relatively large capacitance is used to keep the ripple voltage on the supply line low. This is especially important where the supply line has high impedance. It is recommended however, that the supply-line impedance be kept as low as possible.

The input-capacitor ripple current can be calculated using [Equation 24](#).

$$I_{\text{CAP(RMS)}} = \sqrt{\left[ \left( I_{\text{OUT}} - I_{\text{IN(AVG)}} \right)^2 + \frac{I_{\text{RIPPLE}}^2}{12} \right] \times D + I_{\text{IN(AVG)}}^2 \times (1 - D)} \quad (24)$$

$I_{\text{IN(AVG)}}$  is the average input current. This is calculated simply by multiplying the output dc current by the duty cycle. The ripple current in the input capacitor is 3.3 A. An 1812 MLCC using X5R material has a typical dissipation factor of 5%. For a 22- $\mu\text{F}$  capacitor at 300 kHz, the ESR is approximately 4 m $\Omega$ . Two capacitors are used in parallel, so the power dissipation in each capacitor is less than 11 mW.

A 470- $\mu\text{F}/16\text{-V}$  electrolytic is added to maintain the voltage on the input rail.



### 8.2.1.2.1.4 Switching MOSFET, QSW

The following key parameters must be met by the selected MOSFET.

- Drain source voltage,  $V_{ds}$ , must be able to withstand the input voltage plus spikes that may be on the switching node. For this design a  $V_{ds}$  rating of 30 volts is recommended.
- Drain current,  $I_D$ , at 25°C, must be greater than that calculated using [Equation 25](#).

$$I_{QSW(RMS)} = \sqrt{\frac{V_{OUT}}{V_{IN(MIN)}} \times \left[ I_{OUT(MAX)}^2 + \frac{I_{RIPPLE}^2}{12} \right]} \quad (25)$$

- With the parameters specified, the calculation of  $I_{QSW(RMS)}$  should be greater than 5 A.
- Gate source voltage,  $V_{gs}$ , must be able to withstand the gate voltage from the control IC. For the TPS40077, this is 11 V.

Once the above boundary parameters are defined, the next step in selecting the switching MOSFET is to select the key performance parameters. Efficiency is the performance characteristic which drives the other selection criteria. Target efficiency for this design is 90%. Based on 1.8-V output and 10 A, this equates to a power loss in the converter of 1.8 W. Based on this figure, a target of 0.6 W dissipated in the switching FET was chosen.

[Equation 26](#) through [Equation 29](#) can be used to calculate the power loss,  $P_{QSW}$ , in the switching MOSFET.

$$P_{QSW} = P_{CON} + P_{SW} + P_{GATE} \quad (26)$$

$$P_{CON} = R_{DS(on)} \times I_{QSW(RMS)}^2 = R_{DS(on)} \times \frac{V_{OUT}}{V_{IN}} \times \left[ I_{out}^2 + \frac{I_{RIPPLE}^2}{12} \right] \quad (27)$$

$$P_{SW} = V_{IN} \times f_S \times \left[ \frac{\left( I_{OUT} + \frac{I_{RIPPLE}}{2} \right) \times (Q_{gs1} + Q_{gd})}{I_g} + \frac{Q_{OSS(SW)} + Q_{OSS(SR)}}{12} \right] \quad (28)$$

$$P_{GATE} = Q_{g(TOT)} \times V_g \times f_{SW} \quad (29)$$

where

$P_{CON}$  = conduction losses

$P_{SW}$  = switching losses

$P_{GATE}$  = gate-drive losses

$Q_{gd}$  = drain-source charge or Miller charge

$Q_{gs1}$  = gate-source post-threshold charge

$I_g$  = gate-drive current

$Q_{OSS(SW)}$  = switching MOSFET output charge

$Q_{OSS(SR)}$  = synchronous MOSFET output charge

$Q_{g(TOT)}$  = total gate charge from zero volts to the gate voltage

$V_g$  = gate voltage

If the total estimated loss is split evenly between conduction and switching losses, [Equation 27](#) and [Equation 28](#) yield preliminary values for  $R_{DS(on)}$  and  $(Q_{gs1} + Q_{gd})$ . Note output losses due to  $Q_{OSS}$  and gate losses have been ignored here. Once a MOSFET is selected, these parameters can be added.

The switching MOSFET for this design should have an  $R_{DS(on)}$  of less than 8 mΩ. The sum of  $Q_{gd}$  and  $Q_{gs}$  should be approximately 4 nC.

It may not always be possible to get a MOSFET which meets both these criteria, so a compromise may be necessary. Also, by selecting different MOSFETs close to these criteria and calculating power loss, the final selection can be made. It was found that the Si7860DP MOSFET from Vishay semiconductor gave reasonable results. This device has an  $R_{DS(on)}$  of 8 m $\Omega$  and a ( $Q_{gs1} + Q_{gd}$ ) of 5 nC. The estimated conduction losses are 0.115 W and the switching losses are 0.276 W. This gives a total estimated power loss of 0.391 W versus 0.6 W for our initial boundary condition. Note this does not include gate losses of approximately 71 mW and output losses of 20 mW.

#### 8.2.1.2.1.5 Rectifier MOSFET, QSR

Similar criteria to the foregoing can be used for the rectifier MOSFET. There is one significant difference: due to the body diode conducting, the rectifier MOSFET switches with zero voltage across its drain and source, so effectively with zero switching losses. However, there are some losses in the body diode. These are minimized by reducing the delay time between the transition from the switching MOSFET turnoff to rectifier MOSFET turnon and vice-versa. The TPS40077 incorporates TI's proprietary Predictive Gate Drive circuitry (PGD), which helps reduce these delays to around 10 ns.

To calculate the losses in the rectifier MOSFET, use [Equation 30](#) through [Equation 33](#).

$$P_{QSR} = P_{CON} + P_{BD} + P_{GATE} \quad (30)$$

$$P_{CON} = R_{DS(on)} \times \left[ 1 - \frac{V_{OUT}}{V_{IN}} - (t_1 + t_2) \times f_S \right] \times \left[ I_{out}^2 + \frac{I_{RIPPLE}^2}{12} \right] \quad (31)$$

$$P_{BD} = V_f \times I_{OUT} \times (t_1 + t_2) \times f_S \quad (32)$$

$$P_{GATE} = Q_{g(TOTAL)} \times V_g \times f_S$$

where

- $P_{BD}$  = body diode losses
  - $t_1$  = body diode conduction prior to turnon of channel = 12 ns for PGD
  - $t_2$  = body diode conduction after turnoff of channel = 12 ns for PGD
  - $V_f$  = body diode forward voltage
- (33)

Estimating the body diode losses based on a forward voltage of 1 V gives 0.072 W. The gate losses are unknown at this time, so assume 0.1-W gate losses. This leaves 0.428 W for conduction losses. Using this figure, a target  $R_{DS(on)}$  of 5 m $\Omega$  was calculated.

The Si7336ADP from Vishay was chosen. Using the parameters from its data sheet, the actual expected power losses are calculated. Conduction loss is 0.317 W, body diode loss is 0.072 W, and the gate loss is 0.136W. This totals 0.525 W associated with the rectifier MOSFET.

Two other criteria should be verified before finalizing on the rectifier MOSFET. One is the requirement to ensure that predictive gate drive functions correctly. The turnoff delay of the Si7336ADP is 97 ns. The minimum turnoff delay of the Si7860DP is 25 ns. Together these devices meet the 130-ns requirement.

Secondly, the ratio between  $C_{gs}$  and  $C_{gd}$  should be greater than 1. The Si7336ADP easily meets this criterion. This helps reduce the risk of  $dv/dt$ -induced turnon of the rectifier MOSFET. If this is likely to be a problem, a small resistor may be added in series with the boost capacitor, CBOOST.

#### 8.2.1.2.1.6 Timing Resistor, $R_T$

The timing resistor is calculated using [Equation 34](#).

$$R_T = \frac{1}{f_S \times 17.82 \times 10^{-6}} - 23 \quad (34)$$

This gives a resistor value of 165 k $\Omega$ . The nominal frequency using this resistor is 300 kHz.

#### 8.2.1.2.1.7 Feed-Forward and UVLO Resistor, $R_{KFF}$

A resistor connected to the KFF pin of the IC feeds into the ramp generator. This resistor provides current into the ramp generator proportional to the input voltage. The ramp is then adjusted to compensate for different input voltages. This provides the voltage feed-forward feature of the TPS40077.

The same resistor also sets the undervoltage lockout point. The input start voltage should be used to calculate a value for  $R_{KFF}$ . For this module, the minimum input voltage is 8 V; however, due to tolerances in the IC, a start voltage of 10% less than the minimum input voltage is selected. The start voltage for  $R_{KFF}$  calculation is 7.2 V. Using Equation 35,  $R_{KFF}$  can be selected.

$$R_{KFF} = 0.131 \times R_T \times V_{UVLO(on)} - 1.61 \times 10^{-3} \times V_{UVLO(on)}^2 + 1.886 \times V_{UVLO} - 1.363 - 0.02 \times R_T - 4.87 \times 10^{-5} \times R_T^2$$

where

- $R_{KFF}$  and  $R_T$  are in k $\Omega$  (35)

Equation 35 gives an  $R_{KFF}$  value of 156 k $\Omega$ . The closest lower standard value of 154 k $\Omega$  should be selected. This gives a minimum start voltage of 7.1 V.

#### 8.2.1.2.1.8 Soft-Start Capacitor, CSS

It is good practice to limit the rise time of the output voltage. This helps prevent output overshoot and possible damage to the load. The selection of the soft-start time is arbitrary. It must meet one condition: it should be greater than the time constant of the output filter, LOUT and COUT. This time is given by Equation 36.

$$t_{START} \geq 2\pi \times \sqrt{LOUT \times COUT} \quad (36)$$

The soft-start time must be greater than 0.23 ms. A time of 0.75 ms was chosen. This time also helps limit the initial input current during start-up so that the peak current plus the capacitor start-up current is less than the minimum short-circuit current. The value of CSS can be calculated using Equation 37.

$$C_{SS} = \frac{I_{SS}}{V_{FB}} \times t_{START} \quad (37)$$

A standard 15-nF MLCC capacitor was chosen. The calculated start time using this capacitor is 0.875 ms.

#### 8.2.1.2.1.9 Short-Circuit Protection, $R_{ILIM}$ and $C_{ILIM}$

Short-circuit protection is programmed using the  $R_{ILIM}$  resistor. Selection of this resistor depends on the  $R_{DS(on)}$  of the switching MOSFET selected and the required short-circuit current trip point,  $I_{SCP}$ . The minimum  $I_{SCP}$  is limited by the inductor peak current, the output voltage, the output capacitor, and the soft-start time. Their relationship is given by Equation 38. A short-circuit current trip point greater than that calculated by Equation 38 should be used.

$$I_{SCP} \geq \frac{COUT \times V_{OUT}}{t_{START}} + I_{PK} \quad (38)$$

The minimum short-circuit current trip point for this design is 12.25 A. This value is used in Equation 39 to calculate the minimum  $R_{ILIM}$  value.

$$R_{ILIM} = \frac{I_{SCP} \times R_{DS(on)MAX} + V_{ILIM(MAX)}}{I_{LIM(MIN)}} \quad (39)$$

$R_{ILIM}$  is calculated to be 1.17 k $\Omega$ , and a 1.2-k $\Omega$  resistor is used to verify that the short-circuit current requirements are met. The minimum and maximum short-circuit current can be calculated using Equation 40 and Equation 41.

$$I_{SCP(MIN)} = \frac{I_{ILIM(MIN)} \times R_{ILIM(MIN)} - V_{ILIM(MAX)}}{R_{DS(on)MAX}} \quad (40)$$

$$I_{SCP(MAX)} = \frac{I_{ILIM(MAX)} \times R_{ILIM(MAX)} - V_{ILIM(MIN)}}{R_{DS(on)MIN}} \quad (41)$$

where:  $V_{ILIM(MAX)}$  and  $V_{ILIM(MIN)}$  are maximum and minimum voltages across the high side FET when it is turned on, taking into account temperature variations.

The minimum  $I_{SCP}$  is 12.25 A, and the maximum is 34 A.

It is also recommended to add a small capacitor,  $C_{ILIM}$ , across  $R_{ILIM}$ . The value of this capacitor should be about half the value calculated in Equation 42.

$$C_{ILIM(Max)} = \frac{V_{OUT} \times 0.2}{V_{IN} \times R_{ILIM} \times f_S} \quad (42)$$

This equation yields a maximum  $C_{ILIM}$  as 55 pF. A smaller value of 27 pF is chosen.

#### 8.2.1.2.1.10 Boost Voltage, CBOOST and DBOOST (Optional)

To be able to drive an N-channel MOSFET in the switch location of a buck converter, a capacitor charge pump or boost circuit is required. The TPS40077 contains the elements for this boost circuit. The designer must only add a capacitor, CBOOST, from the switch node of the buck power stage to the BOOST pin of the IC. Selection of this capacitor is based on the total gate charge of the switching MOSFET and the allowable ripple on the boost voltage,  $\Delta V_{BOOST}$ . A ripple of 0.2 V is assumed for this design. Using these two parameters and Equation 43, the minimum value for CBOOST can be calculated.

$$C_{BOOST} > \frac{Q_{g(TOTAL)}}{\Delta V_{BOOST}} \quad (43)$$

The total gate charge of the switching MOSFET is 23 nC. A minimum CBOOST of 0.092  $\mu$ F is required. A 0.1  $\mu$ F capacitor was chosen. This capacitor must be able to withstand the maximum input voltage plus the maximum voltage on DBP. This is 13.2 V plus 9.0 V, which is 22.2 V. A 50-V capacitor is used.

To reduce losses in the TPS40077 and to increase the available gate voltage for the switching MOSFET, an external diode can be added between the DBP pin and the BOOST pin of the IC. A small-signal Schottky diode should be used here, such as the BAT54.

#### 8.2.1.2.1.11 Closing the Feedback Loop, $R_{Z1}$ , $R_{P1}$ , $R_{PZ2}$ , $R_{SET1}$ , $R_{SET2}$ , $C_{Z2}$ , $C_{P2}$ , and $C_{PZ1}$

A graphical method is used to select the compensation components. This is a standard feed-forward buck converter. Its PWM gain is given by Equation 44.

$$K_{PWM} \equiv \frac{V_{UVLO}}{1 \text{ V}} \quad (44)$$

The ramp voltage is 1 V at the UVLO voltage. Because of the feed-forward compensation, the programmed UVLO voltage is the voltage that sets the PWM gain.

The gain of the output LC filter is given by Equation 45.

$$K_{LC} = \frac{1 + s \times ESR \times C_{OUT}}{1 + s \times \frac{L_{OUT}}{R_{OUT}} + s^2 \times L_{OUT} \times C_{OUT}} \quad (45)$$

The PWM and LC gain is Equation 46.

$$G_c(s) = K_{PWM} \times K_{LC} \times \frac{V_{UVLO}}{1 \text{ V}} \times \frac{1 + s \times ESR \times C_{OUT}}{1 + s \times \frac{L_{OUT}}{R_{OUT}} + s^2 \times L_{OUT} \times C_{OUT}} \quad (46)$$

To plot this on a Bode plot, the dc gain must be expressed in dB. The dc gain is equal to  $K_{PWM}$ . To express this in dB, take its logarithm and multiply by 20. For this converter, the dc gain is Equation 47.

$$DCGAIN = 20 \times \log \left[ \frac{V_{UVLO}}{V_{RAMP}} \right] = 20 \times \log(7) = 16.9 \text{ dB} \quad (47)$$

Also, the pole and zero frequencies should be calculated. A double pole is associated with the LC and a zero is associated with the ESR of the output capacitor. The frequencies where these occur can be calculated using Equation 48 and Equation 49.

$$f_{LC\_Pole} = \frac{1}{2\pi \times \sqrt{L_{OUT} \times C_{OUT}}} = 4.3 \text{ kHz} \quad (48)$$

$$f_{ESR\_Zero} = \frac{1}{2\pi \times ESR \times C_{OUT}} = 2.1 \text{ kHz} \quad (49)$$

These are shown in the Bode plot of [Figure 29](#).

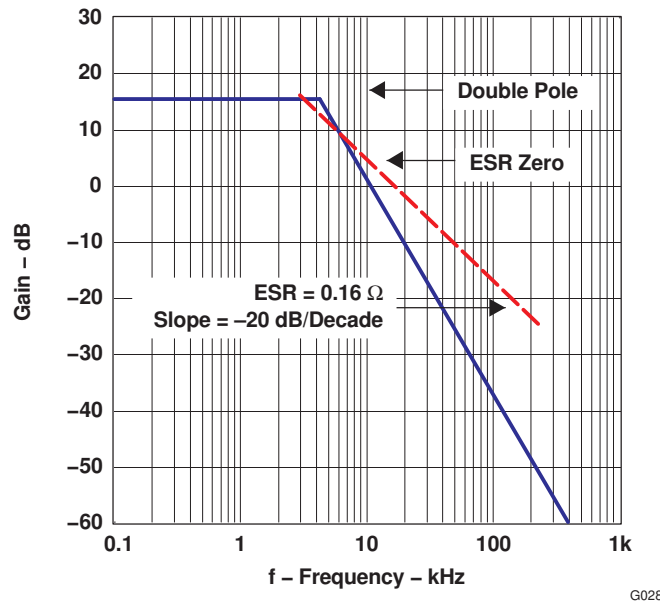

Figure 29. PWM and LC Filter Gain

The next step is to establish the required compensation gain to achieve the desired overall system response. The target response is to have the crossover frequency between 1/9 and 1/5 times the switching frequency, in order to have a phase margin greater than 45° and a gain margin greater than 6 dB.

A type-III compensation network, shown in [Figure 30](#), was used for this design. This network gives the best overall flexibility for compensating the converter.

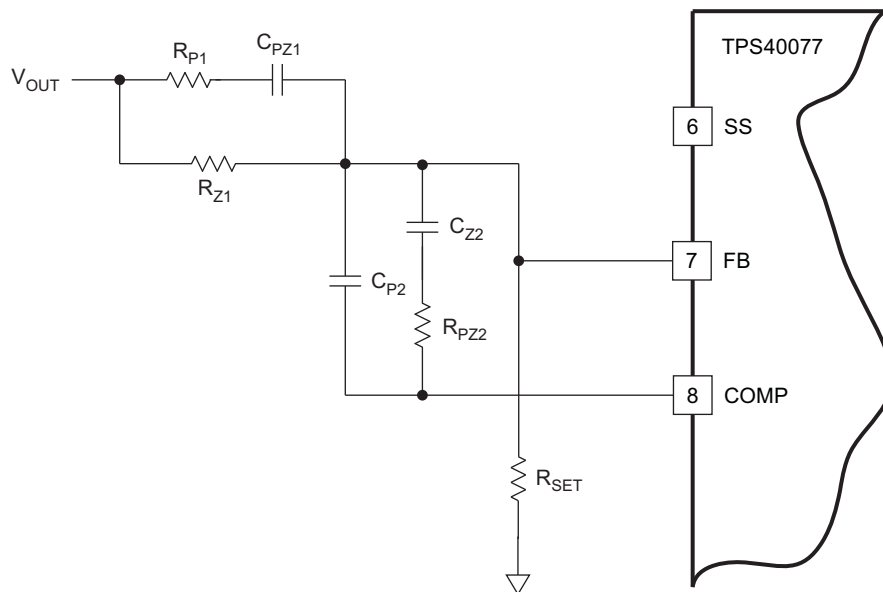
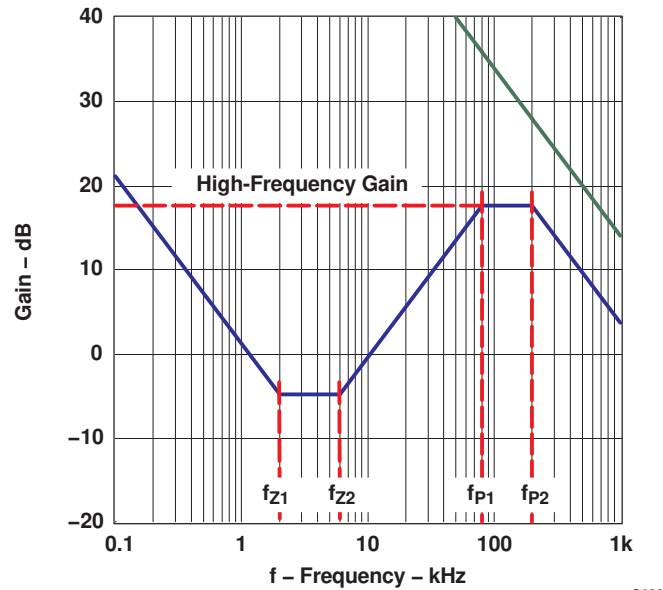

Figure 30. Type-III Compensation With the TPS40077

A typical Bode plot for this type of compensation network is shown in [Figure 31](#).

**Figure 31. Type-III Compensation Typical Bode Plot**

The high-frequency gain and the break (pole and zero) frequencies are calculated using [Equation 50](#) through [Equation 55](#).

$$V_{OUT} = V_{REF} \times \frac{R_{Z1} + R_{SET}}{R_{SET}} \quad (50)$$

$$GAIN = R_{PZ2} \times \frac{R_{Z1} + R_{P1}}{R_{Z1} \times R_{P1}} \quad (51)$$

$$f_{P1} = \frac{1}{2\pi \times R_{P1} \times C_{PZ1}} \quad (52)$$

$$f_{P2} = \frac{C_{P2} + C_{Z2}}{2\pi \times R_{PZ2} \times C_{P2} \times C_{Z2}} \approx \frac{1}{2\pi \times R_{PZ2} \times C_{P2}} \quad (53)$$

$$f_{Z1} = \frac{1}{2\pi \times R_{Z1} \times C_{PZ1}} \quad (54)$$

$$f_{Z2} = \frac{1}{2\pi \times (R_{PZ2} + R_{P1}) \times C_{Z2}} \approx \frac{1}{2\pi \times R_{PZ2} \times C_{Z2}} \quad (55)$$

Looking at the PWM and LC bode plot, there are a few things which must be done to achieve stability.

1. Place two zeros close to the double pole, e.g.,  $f_{Z1} = f_{Z2} = 4.3$  kHz
2. Place both poles well above the crossover frequency. The crossover frequency was selected as one sixth the switching frequency,  $f_{co1} = 50$  kHz,  $f_{P1} = 66$  kHz
3. Place the second pole at three times  $f_{co1}$ . This ensures that the overall system gain falls off quickly to give good gain margin,  $f_{P2} = 150$  kHz
4. The high-frequency gain should be sufficient to ensure 0 dB at the required crossover frequency,  $GAIN = -1 \times$  gain of PWM and LC at the crossover frequency,  $GAIN = 16.9$  dB

Using these values and [Equation 50](#) through [Equation 55](#), the Rs and Cs around the compensation network can be calculated.

1. Set  $R_{Z1} = 51$  k $\Omega$
2. Calculate  $R_{SET}$  using [Equation 50](#),  $R_{SET} = 32.4$  k $\Omega$
3. Using [Equation 54](#) and  $f_{Z1} = 4.3$  kHz,  $C_{PZ1}$  can be calculated to be 726 pF,  $C_{PZ1} = 680$  pF

4.  $f_{P1}$  and Equation 52 yields  $R_{P1}$  to be a standard value of 3.3 k $\Omega$ .
5. The required gain of 16.9 dB and Equation 51 sets the value for  $R_{PZ2}$ .  $R_{PZ2} = 21.5$  k $\Omega$ .
6.  $C_{Z2}$  is calculated using Equation 55 and the desired frequency for the second zero,  $C_{Z2} = 1.7$  nF, or using standard values, 1.8 nF.
7. Finally,  $C_{P2}$  is calculated using the second pole frequency and Equation 53;  $C_{P2} = 47$  pF.

Using these values, the simulated results are 57° of phase margin at 54 kHz.

### 8.2.1.3 Application Curves

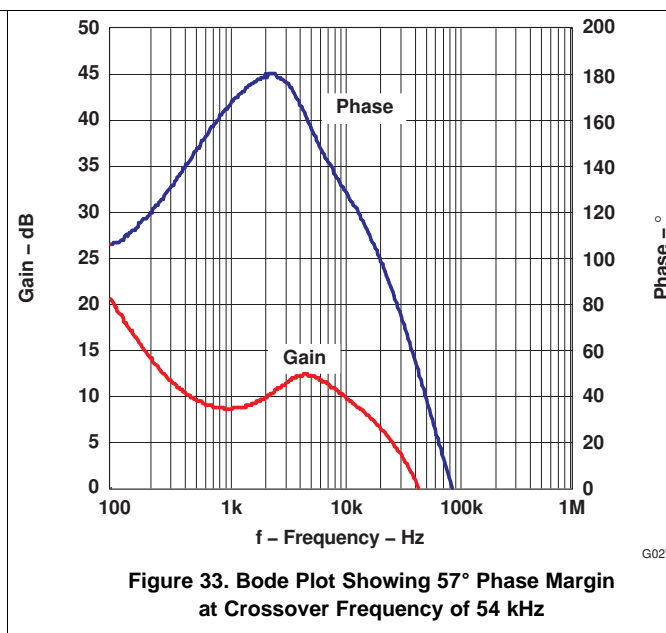
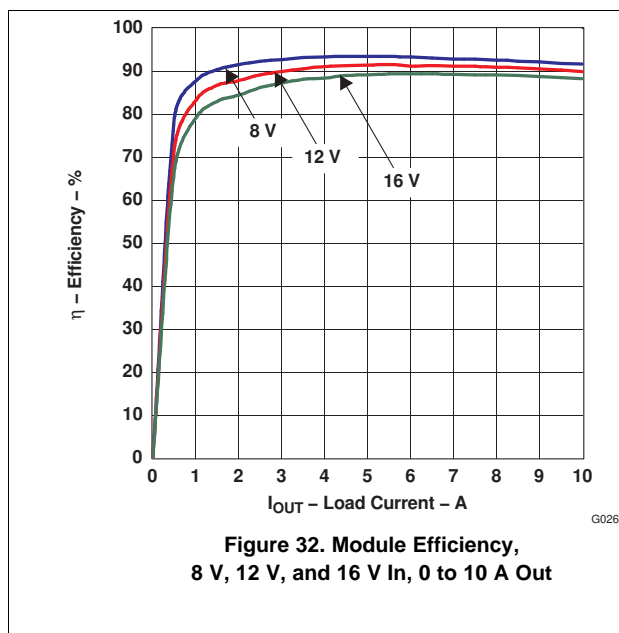

### 8.3 Additional System Examples

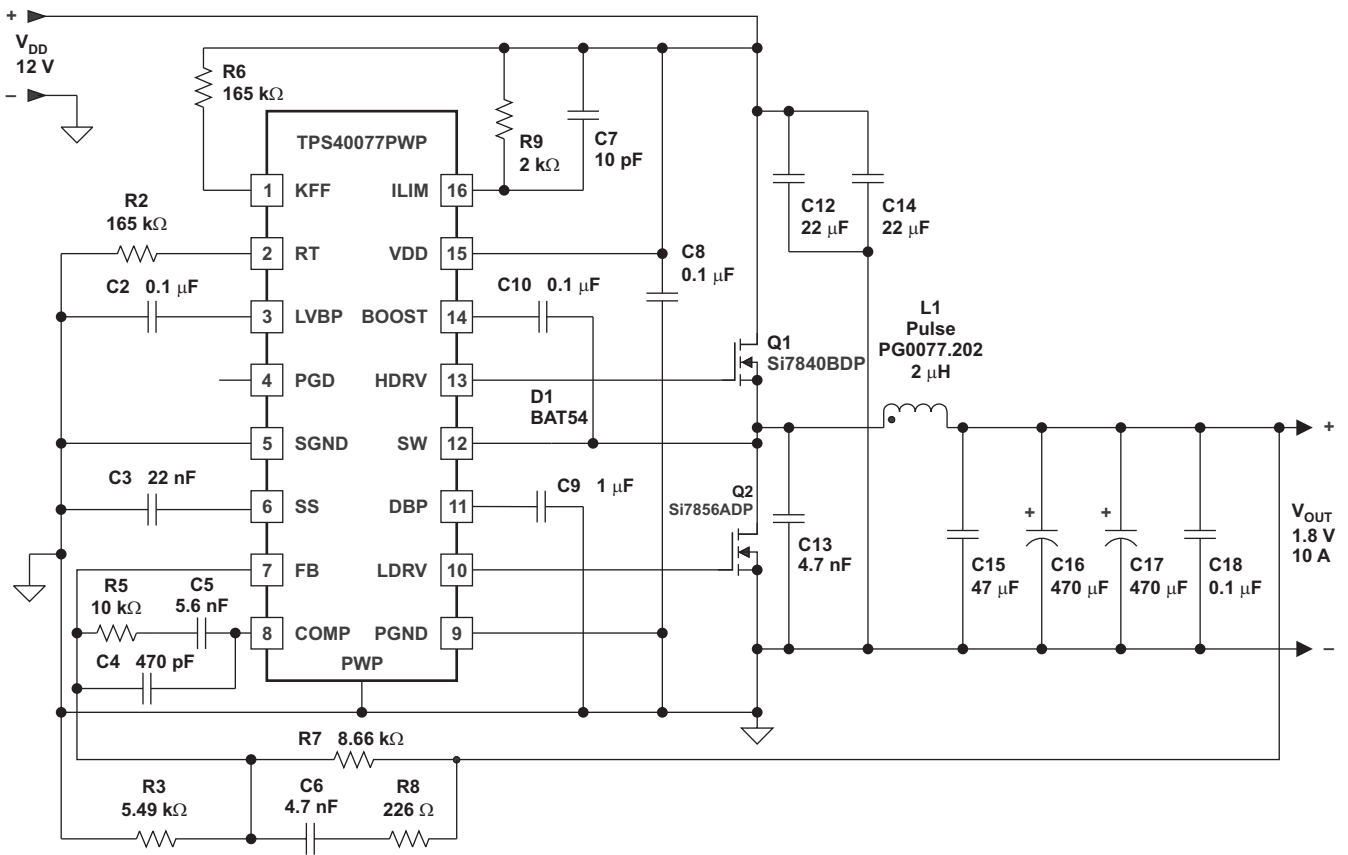

S0209-01

Figure 34. 300 kHz, 12 V to 1.8 V



Additional System Examples (continued)

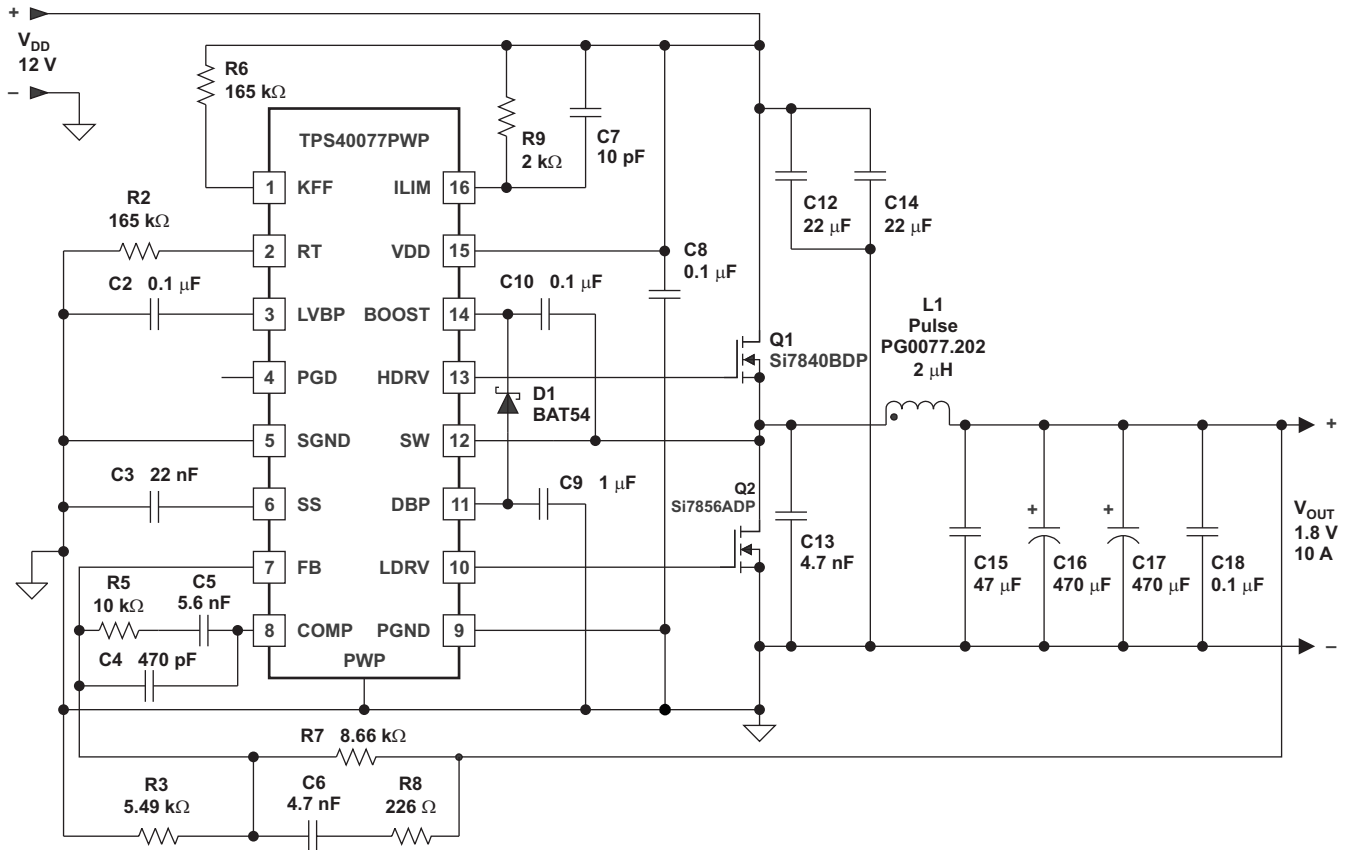

S0210-01

See [Boost Diode](#).

Figure 35. 300 kHz, 12 V to 1.8 V With Improved High-Side Gate Drive

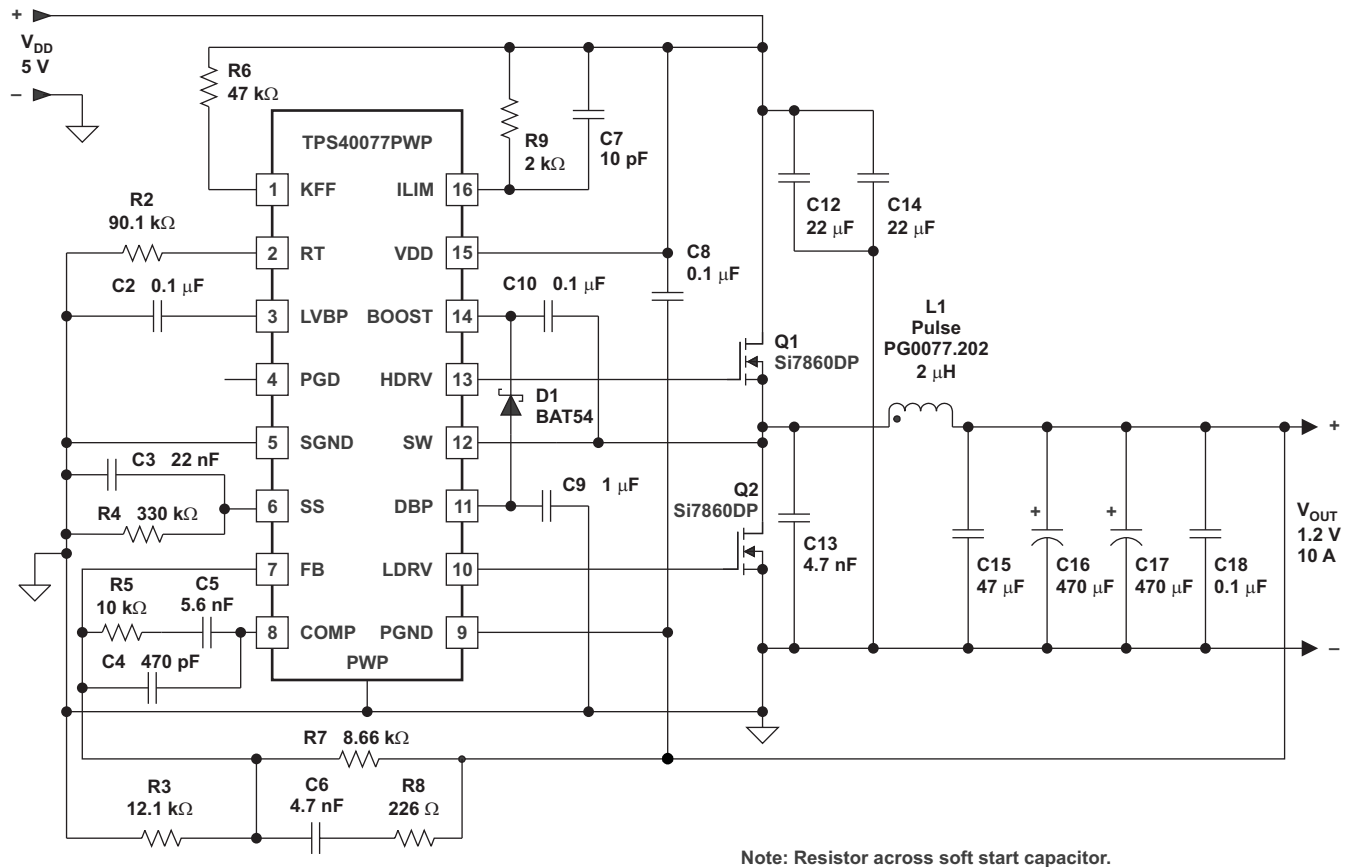
**Additional System Examples (continued)**

S0211-01

 See [Boost Diode](#).

**Figure 36. 500 kHz, 5 V to 1.2 V With Improved High-Side Gate Drive**

## 9 Layout

### 9.1 Layout Guidelines

The TPS40077 provides separate signal ground (SGND) and power ground (PGND) pins. Take care to properly separation of the circuit grounds. Each ground must consist of a plane to minimize its impedance, if possible. The high-power *noisy* circuits such as the output, synchronous rectifier, MOSFET driver decoupling capacitor (DBP), and the input capacitor should be connected to PGND plane.

Connect sensitive nodes such as the FB resistor divider and RT to the SGND plane. The SGND plane must only make a single-point connection to the PGND plane. TI recommends that the SGND pin be tied to the copper area for the thermal pad underneath the chip. Tie the PGND to the thermal-pad copper area as well, and make the connection to the power circuit ground from the PGND pin. Reference the output voltage divider to the SGND pin.

Component placement must ensure that bypass capacitors (LVPB and DBP) are located as close as possible to their respective power and ground pins. Also, sensitive circuits such as FB, RT and ILIM should not be located near high-dv/dt nodes such as HDRV, LDRV, BOOST, and the switch node (SW). Failure to follow careful layout practices results in suboptimal operation. More detailed information can be found in the TPS40077EVM user's guide ([SLVU192](#)).

## 10 器件和文档支持

### 10.1 器件支持

#### 10.1.1 第三方产品免责声明

TI 发布的与第三方产品或服务有关的信息，不能构成与此类产品或服务或保修的适用性有关的认可，不能构成此类产品或服务单独或与任何 TI 产品或服务一起的表示或认可。

### 10.2 文档支持

#### 10.2.1 相关文档

请参阅如下相关文档：

- 《PowerPAD 耐热增强型封装》， [SLMA002](#)
- 《TPS40190 低引脚数同步降压控制器》， [SLUS658](#)
- 《具有高级排序功能和输出裕量的 TPS40100 中端输入同步控制器》， [SLUS601](#)
- 《具有电压前馈功能的 TPS40075 中端输入同步降压控制器》， [SLUS676](#)
- 《TPS40057 宽输入同步降压控制器》， [SLUS593](#)
- 《使用 TPS40077EVM 12V 输入、1.8V 输出、10A 同步降压转换器》， [SLVU192](#)

### 10.3 接收文档更新通知

要接收文档更新通知，请导航至 [TI.com.cn](http://TI.com.cn) 上的器件产品文件夹。单击右上角的通知我进行注册，即可每周接收产品信息更改摘要。有关更改的详细信息，请查看任何已修订文档中包含的修订历史记录。

### 10.4 社区资源

The following links connect to TI community resources. Linked contents are provided "AS IS" by the respective contributors. They do not constitute TI specifications and do not necessarily reflect TI's views; see TI's [Terms of Use](#).

**TI E2E™ Online Community** *TI's Engineer-to-Engineer (E2E) Community*. Created to foster collaboration among engineers. At [e2e.ti.com](http://e2e.ti.com), you can ask questions, share knowledge, explore ideas and help solve problems with fellow engineers.

**Design Support** *TI's Design Support* Quickly find helpful E2E forums along with design support tools and contact information for technical support.

### 10.5 商标

PowerPAD, E2E are trademarks of Texas Instruments.  
All other trademarks are the property of their respective owners.

### 10.6 静电放电警告



这些装置包含有限的内置 ESD 保护。存储或装卸时，应将导线一起截短或将装置放置于导电泡棉中，以防止 MOS 门极遭受静电损伤。

### 10.7 Glossary

[SLYZ022](#) — *TI Glossary*.

This glossary lists and explains terms, acronyms, and definitions.

## 11 机械、封装和可订购信息

以下页面包含机械、封装和可订购信息。这些信息是指定器件的最新可用数据。数据如有变更，恕不另行通知，且不会对此文档进行修订。如需获取此数据表的浏览器版本，请查阅左侧的导航栏。

## PACKAGING INFORMATION

Orderable Device	Status (1)	Package Type	Package Drawing	Pins	Package Qty	Eco Plan (2)	Lead finish/ Ball material (6)	MSL Peak Temp (3)	Op Temp (°C)	Device Marking (4/5)	Samples
TPS40077PWP	ACTIVE	HTSSOP	PWP	16	90	RoHS & Green	NIPDAU	Level-2-260C-1 YEAR	-40 to 85	40077	<a href="#">Samples</a>
TPS40077PWPR	ACTIVE	HTSSOP	PWP	16	2000	RoHS & Green	NIPDAU	Level-2-260C-1 YEAR	-40 to 85	40077	<a href="#">Samples</a>
TPS40077PWPRG4	ACTIVE	HTSSOP	PWP	16	2000	RoHS & Green	NIPDAU	Level-2-260C-1 YEAR	-40 to 85	40077	<a href="#">Samples</a>

(1) The marketing status values are defined as follows:

**ACTIVE:** Product device recommended for new designs.

**LIFEBUY:** TI has announced that the device will be discontinued, and a lifetime-buy period is in effect.

**NRND:** Not recommended for new designs. Device is in production to support existing customers, but TI does not recommend using this part in a new design.

**PREVIEW:** Device has been announced but is not in production. Samples may or may not be available.

**OBsolete:** TI has discontinued the production of the device.

(2) **RoHS:** TI defines "RoHS" to mean semiconductor products that are compliant with the current EU RoHS requirements for all 10 RoHS substances, including the requirement that RoHS substance do not exceed 0.1% by weight in homogeneous materials. Where designed to be soldered at high temperatures, "RoHS" products are suitable for use in specified lead-free processes. TI may reference these types of products as "Pb-Free".

**RoHS Exempt:** TI defines "RoHS Exempt" to mean products that contain lead but are compliant with EU RoHS pursuant to a specific EU RoHS exemption.

**Green:** TI defines "Green" to mean the content of Chlorine (Cl) and Bromine (Br) based flame retardants meet JS709B low halogen requirements of <=1000ppm threshold. Antimony trioxide based flame retardants must also meet the <=1000ppm threshold requirement.

(3) MSL, Peak Temp. - The Moisture Sensitivity Level rating according to the JEDEC industry standard classifications, and peak solder temperature.

(4) There may be additional marking, which relates to the logo, the lot trace code information, or the environmental category on the device.

(5) Multiple Device Markings will be inside parentheses. Only one Device Marking contained in parentheses and separated by a "~" will appear on a device. If a line is indented then it is a continuation of the previous line and the two combined represent the entire Device Marking for that device.

(6) Lead finish/Ball material - Orderable Devices may have multiple material finish options. Finish options are separated by a vertical ruled line. Lead finish/Ball material values may wrap to two lines if the finish value exceeds the maximum column width.

**Important Information and Disclaimer:**The information provided on this page represents TI's knowledge and belief as of the date that it is provided. TI bases its knowledge and belief on information provided by third parties, and makes no representation or warranty as to the accuracy of such information. Efforts are underway to better integrate information from third parties. TI has taken and continues to take reasonable steps to provide representative and accurate information but may not have conducted destructive testing or chemical analysis on incoming materials and chemicals. TI and TI suppliers consider certain information to be proprietary, and thus CAS numbers and other limited information may not be available for release.

In no event shall TI's liability arising out of such information exceed the total purchase price of the TI part(s) at issue in this document sold by TI to Customer on an annual basis.

**TAPE AND REEL INFORMATION**

**QUADRANT ASSIGNMENTS FOR PIN 1 ORIENTATION IN TAPE**

\*All dimensions are nominal

Device	Package Type	Package Drawing	Pins	SPQ	Reel Diameter (mm)	Reel Width W1 (mm)	A0 (mm)	B0 (mm)	K0 (mm)	P1 (mm)	W (mm)	Pin1 Quadrant
TPS40077PWPR	HTSSOP	PWP	16	2000	330.0	12.4	6.9	5.6	1.6	8.0	12.0	Q1

**TAPE AND REEL BOX DIMENSIONS**

\*All dimensions are nominal

Device	Package Type	Package Drawing	Pins	SPQ	Length (mm)	Width (mm)	Height (mm)
TPS40077PWPR	HTSSOP	PWP	16	2000	350.0	350.0	43.0

**TUBE**

\*All dimensions are nominal

Device	Package Name	Package Type	Pins	SPQ	L (mm)	W (mm)	T (μm)	B (mm)
TPS40077PWP	PWP	HTSSOP	16	90	530	10.2	3600	3.5





Images above are just a representation of the package family, actual package may vary.  
Refer to the product data sheet for package details.

# PWP0016A

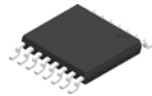

# PACKAGE OUTLINE

## PowerPAD™ HTSSOP - 1.2 mm max height

PLASTIC SMALL OUTLINE

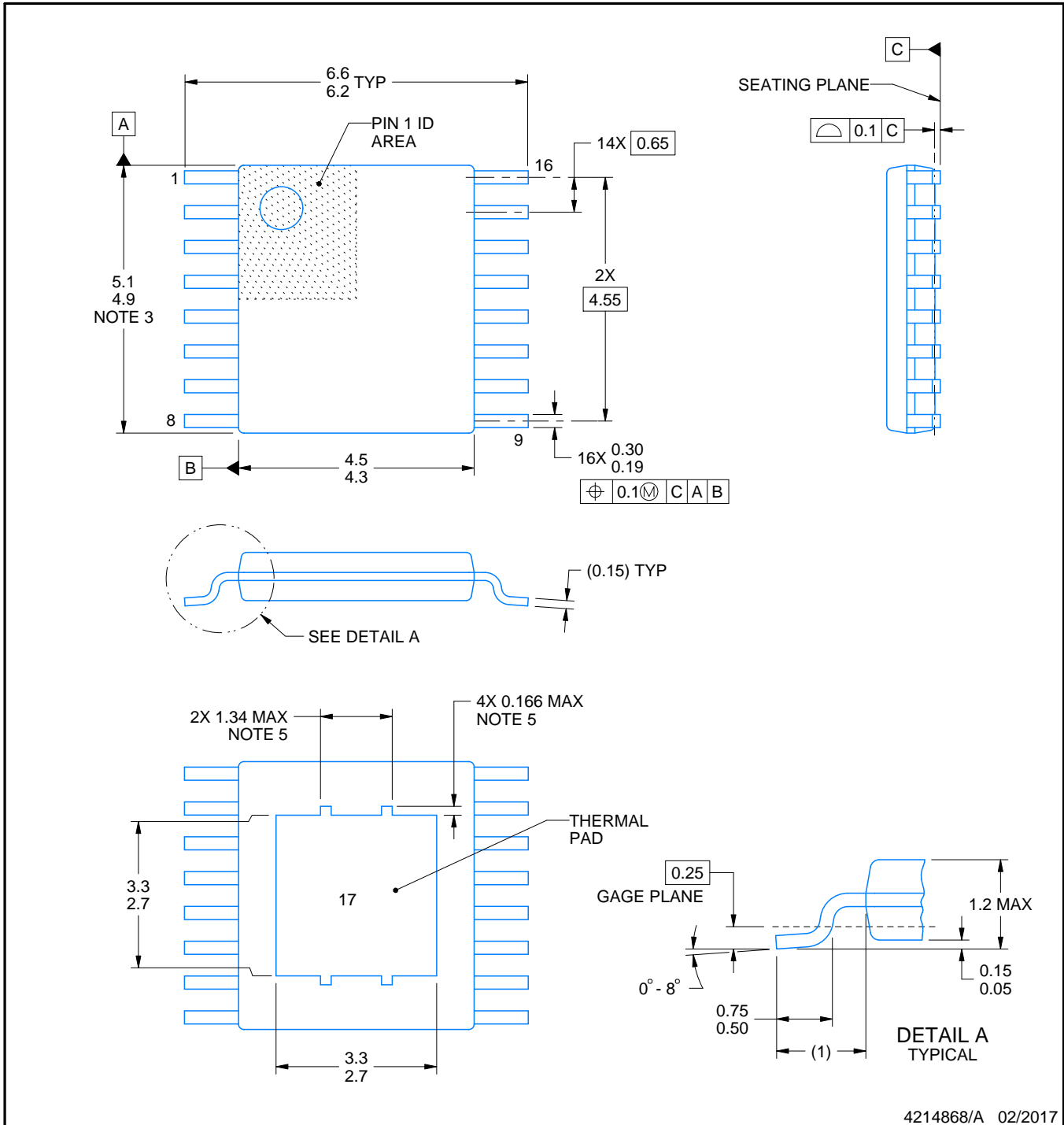

4214868/A 02/2017

### NOTES:

PowerPAD is a trademark of Texas Instruments.

1. All linear dimensions are in millimeters. Any dimensions in parenthesis are for reference only. Dimensioning and tolerancing per ASME Y14.5M.
2. This drawing is subject to change without notice.
3. This dimension does not include mold flash, protrusions, or gate burrs. Mold flash, protrusions, or gate burrs shall not exceed 0.15 mm per side.
4. Reference JEDEC registration MO-153.
5. Features may not be present.

# EXAMPLE BOARD LAYOUT

PWP0016A

PowerPAD™ HTSSOP - 1.2 mm max height

PLASTIC SMALL OUTLINE

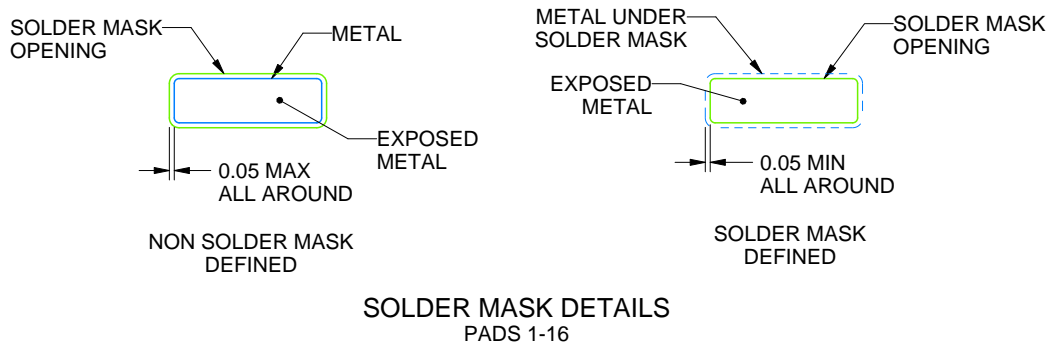
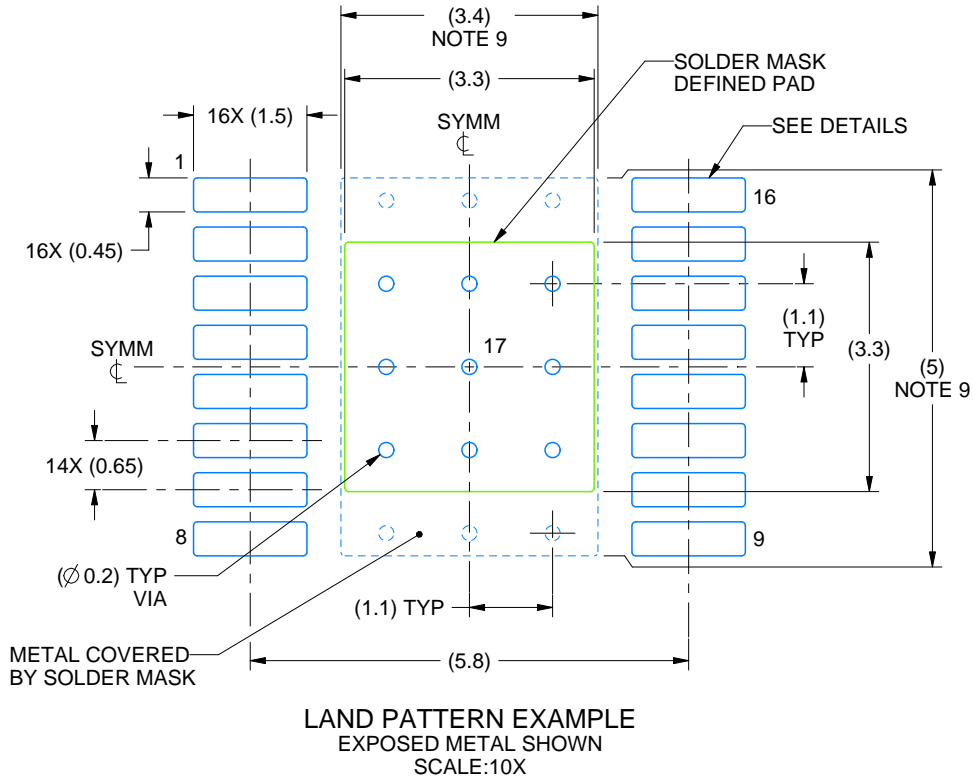

4214868/A 02/2017

NOTES: (continued)

6. Publication IPC-7351 may have alternate designs.
7. Solder mask tolerances between and around signal pads can vary based on board fabrication site.
8. This package is designed to be soldered to a thermal pad on the board. For more information, see Texas Instruments literature numbers SLMA002 ([www.ti.com/lit/slma002](http://www.ti.com/lit/slma002)) and SLMA004 ([www.ti.com/lit/slma004](http://www.ti.com/lit/slma004)).
9. Size of metal pad may vary due to creepage requirement.

# EXAMPLE STENCIL DESIGN

PWP0016A

PowerPAD™ HTSSOP - 1.2 mm max height

PLASTIC SMALL OUTLINE

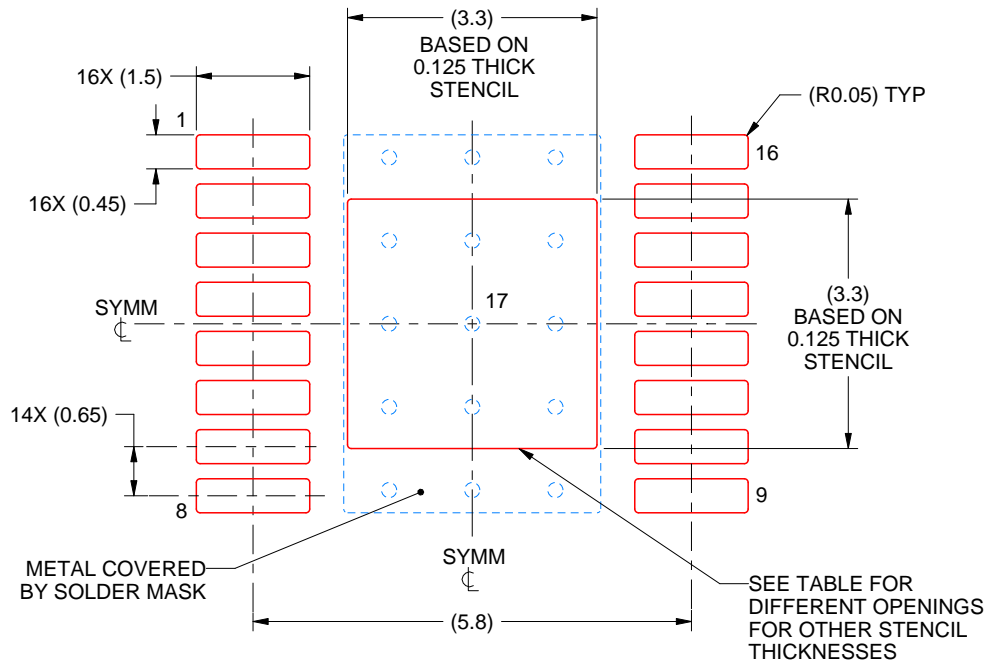

**SOLDER PASTE EXAMPLE**  
 EXPOSED PAD  
 100% PRINTED SOLDER COVERAGE BY AREA  
 SCALE:10X

STENCIL THICKNESS	SOLDER STENCIL OPENING
0.1	3.69 X 3.69
0.125	3.3 X 3.3 (SHOWN)
0.15	3.01 X 3.01
0.175	2.79 X 2.79

4214868/A 02/2017

NOTES: (continued)

10. Laser cutting apertures with trapezoidal walls and rounded corners may offer better paste release. IPC-7525 may have alternate design recommendations.
11. Board assembly site may have different recommendations for stencil design.

## 重要通知和免责声明

TI“按原样”提供技术和可靠性数据（包括数据表）、设计资源（包括参考设计）、应用或其他设计建议、网络工具、安全信息和其他资源，不保证没有瑕疵且不做任何明示或暗示的担保，包括但不限于对适销性、某特定用途方面的适用性或不侵犯任何第三方知识产权的暗示担保。

这些资源可供使用 TI 产品进行设计的熟练开发人员使用。您将自行承担以下全部责任：(1) 针对您的应用选择合适的 TI 产品，(2) 设计、验证并测试您的应用，(3) 确保您的应用满足相应标准以及任何其他功能安全、信息安全、监管或其他要求。

这些资源如有变更，恕不另行通知。TI 授权您仅可将这些资源用于研发本资源所述的 TI 产品的相关应用。严禁以其他方式对这些资源进行复制或展示。您无权使用任何其他 TI 知识产权或任何第三方知识产权。您应全额赔偿因在这些资源的使用中对 TI 及其代表造成的任何索赔、损害、成本、损失和债务，TI 对此概不负责。

TI 提供的产品受 [TI 的销售条款](#) 或 [ti.com](#) 上其他适用条款/TI 产品随附的其他适用条款的约束。TI 提供这些资源并不会扩展或以其他方式更改 TI 针对 TI 产品发布的适用的担保或担保免责声明。

TI 反对并拒绝您可能提出的任何其他或不同的条款。

邮寄地址：Texas Instruments, Post Office Box 655303, Dallas, Texas 75265  
版权所有 © 2025，德州仪器 (TI) 公司