

## TPS61097A-33 具有静态电流的低输入电压同步升压转换器

### 1 特性

- 在典型工作条件下效率高达 93%
- 在关断模式下通过旁路开关从电池连接到负载
- 关断电流典型值小于 5nA
- 静态电流典型值小于 5 $\mu$ A
- 工作输入电压范围为 0.9V 至 5.5V
- 节能模式可提升低输出功率条件下的效率
- 过热保护
- 小型 2.8mm x 2.9mm 5 引脚小外形尺寸晶体管 (SOT)-23 封装

### 2 应用

- MSP430 应用
- 所有使用单节、双节和三节碱性电池、镍镉 (NiCd) 电池、镍氢 (NiMH) 电池，或者单节锂电池供电的产品
- 个人医疗产品
- 使用燃料电池和太阳能电池供电的产品
- 掌上电脑 (PDA)
- 移动应用
- 白色 LED

### 3 说明

TPS61097A-33 可以为由单节、双节和三节碱性电池、镍镉 (NiCd) 电池、镍氢 (NiMH) 电池，或单节锂离子电池以及锂聚合物电池供电的产品提供电源解决方案。这类器件也可用于由燃料电池和太阳能电池供电的设备，对处理低输入电压尤为实用。可提供的输出电流取决于输入输出电压比。使用单节锂离子电池或锂聚合物电池供电时，此器件在 3.3V 输出电压下能提供高达 100mA 的输出电流。升压转换器基于电流模式的控制器，该控制器可利用同步整流实现最大效率。最大平均输入电流值限制为 400mA。通过禁用转换器可以尽量减少电池消耗。关断期间，将电池连接至负载后可以针对负载的重要功能启用备用电池。此器件采用 2.8mm x 2.9mm 5 引脚 SOT-23 封装 (DBV)。

#### 器件信息<sup>(1)</sup>

器件型号	封装	封装尺寸 (标称值)
TPS61097A-33	SOT-23 (5)	2.90mm x 2.90mm

(1) 如需了解所有可用封装，请见数据表末尾的可订购产品附录。

典型工作应用电路

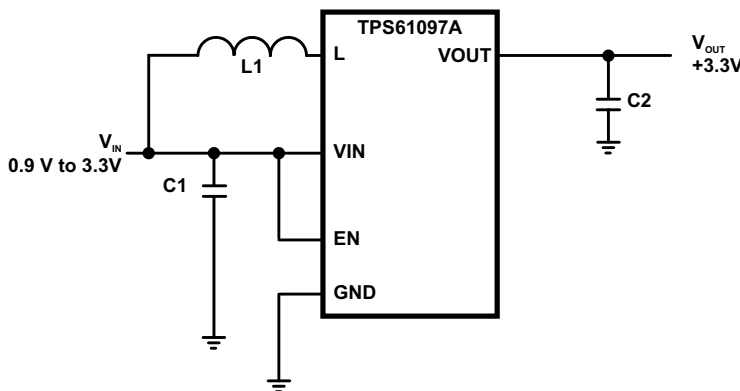

## 目录

<b>1</b>	特性 .....	<b>1</b>	8.3	Feature Description .....	<b>10</b>
<b>2</b>	应用 .....	<b>1</b>	8.4	Device Functional Modes .....	<b>11</b>
<b>3</b>	说明 .....	<b>1</b>	<b>9</b>	<b>Application and Implementation</b> .....	<b>12</b>
<b>4</b>	修订历史记录 .....	<b>2</b>	9.1	Application Information .....	<b>12</b>
<b>5</b>	<b>Pin Configuration and Functions</b> .....	<b>3</b>	9.2	Typical Application .....	<b>13</b>
<b>6</b>	<b>Specifications</b> .....	<b>3</b>	<b>10</b>	<b>Power Supply Recommendations</b> .....	<b>16</b>
6.1	Absolute Maximum Ratings .....	<b>3</b>	<b>11</b>	<b>Layout</b> .....	<b>16</b>
6.2	ESD Ratings .....	<b>3</b>	11.1	Layout Guidelines .....	<b>16</b>
6.3	Recommended Operating Conditions .....	<b>3</b>	11.2	Layout Example .....	<b>16</b>
6.4	Thermal Information .....	<b>4</b>	<b>12</b>	器件和文档支持 .....	<b>17</b>
6.5	Electrical Characteristics .....	<b>4</b>	12.1	器件支持 .....	<b>17</b>
6.6	Typical Characteristics .....	<b>5</b>	12.2	商标 .....	<b>17</b>
<b>7</b>	<b>Parameter Measurement Information</b> .....	<b>8</b>	12.3	静电放电警告 .....	<b>17</b>
<b>8</b>	<b>Detailed Description</b> .....	<b>9</b>	12.4	术语表 .....	<b>17</b>
8.1	Overview .....	<b>9</b>	<b>13</b>	机械封装和可订购信息 .....	<b>17</b>
8.2	Functional Block Diagram .....	<b>9</b>			

## 4 修订历史记录

### Changes from Original (January 2014) to Revision A

**Page**

- 已添加 处理额定值表, 特性描述部分, 器件功能模式, 应用和实施部分, 电源相关建议部分, 布局部分, 器件和文档支持部分以及机械、封装和可订购信息部分 ..... **1**

## 5 Pin Configuration and Functions

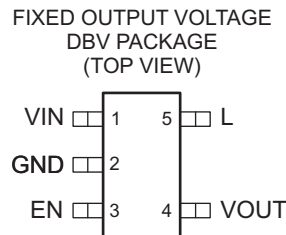

### Pin Functions

PIN		I/O	DESCRIPTION
NO.	NAME		
1	VIN	I	Boost converter input voltage.
2	GND	–	Control / logic ground.
3	EN	I	Enable input (1 = enabled, 0 = disabled). EN must be actively terminated high or low.
4	VOUT	O	Boost converter output.
5	L	I	Connection for inductor.

## 6 Specifications

### 6.1 Absolute Maximum Ratings

Over operating free-air temperature range (unless otherwise noted)<sup>(1)</sup>

		MIN	MAX	UNIT	
V <sub>I</sub>	Input voltage range	VIN	–0.3	7	V
		L	–0.3	7	
		VOUT	–0.3	7	
		EN	–0.3	7	
I <sub>MAX</sub>	Maximum continuous output current		400	mA	
T <sub>J</sub>	Junction temperature range	–40	150	°C	
T <sub>stg</sub>	Storage temperature range	–65	150	°C	

(1) Stresses beyond those listed under *Absolute Maximum Ratings* may cause permanent damage to the device. These are stress ratings only, and functional operation of the device at these or any other conditions beyond those indicated under *Recommended Operating Conditions* is not implied. Exposure to absolute-maximum-rated conditions for extended periods may affect device reliability.

### 6.2 ESD Ratings

		VALUE	UNIT	
V <sub>(ESD)</sub>	Electrostatic discharge	Human-body model (HBM), per ANSI/ESDA/JEDEC JS-001 <sup>(1)</sup>	±2000	V
		Charged-device model (CDM), per JEDEC specification JESD22-C101 <sup>(2)</sup>	±1000	

(1) JEDEC document JEP155 states that 500-V HBM allows safe manufacturing with a standard ESD control process.

(2) JEDEC document JEP157 states that 250-V CDM allows safe manufacturing with a standard ESD control process.

### 6.3 Recommended Operating Conditions

		MIN	MAX	UNIT
V <sub>IN</sub>	Input voltage range	0.9	5.5	V
V <sub>EN</sub>	Enable voltage range	0	5.5	V
T <sub>A</sub>	Operating free air temperature range	–40	85	°C
T <sub>J</sub>	Operating junction temperature range	–40	125	°C

## 6.4 Thermal Information

THERMAL METRIC <sup>(1)</sup>		TPS61097A-33		UNIT
		DBV		
		5 PINS		
$\theta_{JA}$	Junction-to-ambient thermal resistance	208.7		°C/W
$\theta_{JCTop}$	Junction-to-case (top) thermal resistance	124.5		
$\theta_{JB}$	Junction-to-board thermal resistance	36.9		
$\psi_{JT}$	Junction-to-top characterization parameter	14.7		
$\psi_{JB}$	Junction-to-board characterization parameter	36		

(1) For more information about traditional and new thermal metrics, see the *IC Package Thermal Metrics* application report, [SPRA953](#).

## 6.5 Electrical Characteristics

Over recommended free-air temperature range and over recommended input voltage range (typical at an ambient temperature range of 25°C) (unless otherwise noted)

PARAMETER		TEST CONDITIONS	MIN	TYP	MAX	UNIT	
<b>DC/DC STAGE</b>							
$V_{IN}$	Input voltage		0.9		5.5	V	
$V_{OUT}$	Output voltage	$V_{IN} = 1.2\text{ V}, I_{OUT} = 10\text{ mA}$	3.20	3.30	3.40		
$I_{SW}$	Switch current limit	$V_{OUT} = 3.3\text{ V}$	200	400	475	mA	
	Rectifying switch on resistance	$V_{OUT} = 3.3\text{ V}$		1.0		Ω	
	Main switch on resistance	$V_{OUT} = 3.3\text{ V}$		1.0			
	Bypass switch on resistance	$V_{IN} = 1.2\text{ V}, I_{OUT} = 100\text{ mA}$		3.4			
	Line regulation	$V_{IN} < V_{OUT}, V_{IN} = 1.2\text{ V to } 1.8\text{ V}, I_{OUT} = 10\text{ mA}$		0.5%			
	Load regulation	$V_{IN} < V_{OUT}, I_{OUT} = 10\text{ mA to } 50\text{ mA}, V_{IN} = 1.8\text{ V}$		0.5%			
$I_Q$	Quiescent current	$V_{IN}$	$I_{OUT} = 0\text{ mA}, V_{EN} = V_{IN} = 1.2\text{ V}, V_{OUT} = 3.5\text{ V}$		2	4	μA
		$V_{OUT}$			5	8	
$I_{SD}$	Shutdown current	$V_{IN}$	$V_{EN} = 0\text{ V}, V_{IN} = 1.2\text{ V}, I_{OUT} = 0\text{ mA}$		0.005	0.15	μA
		$V_{IN}$			$V_{EN} = 0\text{ V}, V_{IN} = 3\text{ V}, I_{OUT} = 0\text{ mA}$		
	Leakage current into L	$V_{EN} = 0\text{ V}, V_{IN} = 1.2\text{ V}, V_L = 1.2\text{ V}$		0.01			1
<b>CONTROL STAGE</b>							
	EN input current	$EN = 0\text{ V or } EN = V_{IN}$		0.01	0.1	μA	
$V_{IL}$	Logic low level, EN falling edge				0.58	V	
$V_{IH}$	Logic high level, EN rising edge		0.78		$V_{IN} + 1.0\text{ V}$		
OTP	Overtemperature protection			150		°C	
OTP <sub>HYST</sub>	Overtemperature hysteresis			20			
$V_{UVLO}$	Undervoltage lock-out threshold for turn off	$V_{IN}$ decreasing		0.6	0.8	V	

## 6.6 Typical Characteristics

Refer to [Figure 19](#) for reference designators.

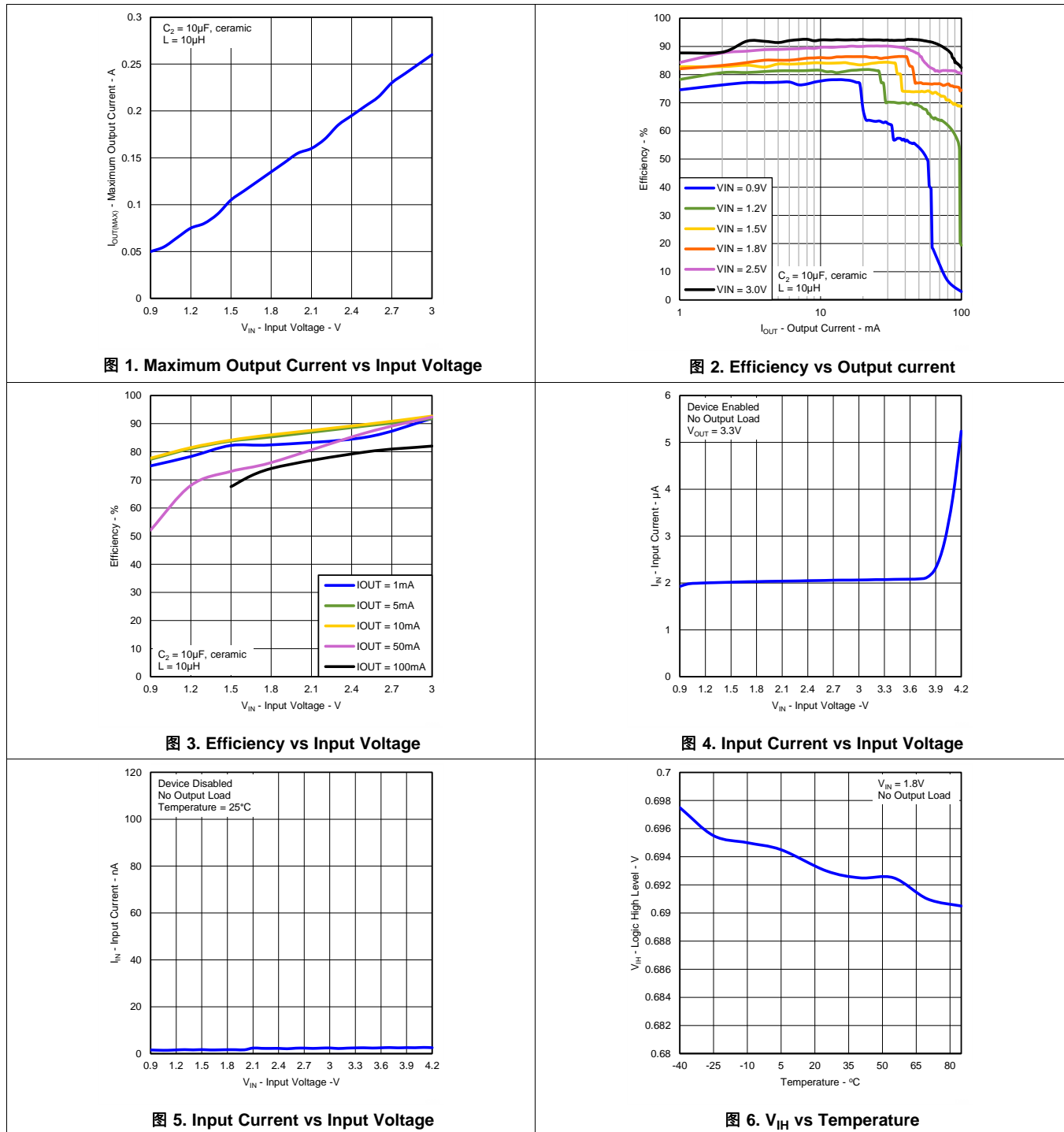

Typical Characteristics (接下页)



图 7.  $V_{IH}$  vs Output Current



图 8. Output Voltage vs Output Current

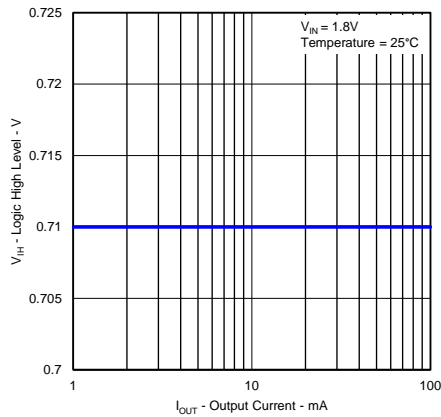

图 9. Output Voltage vs Input Voltage

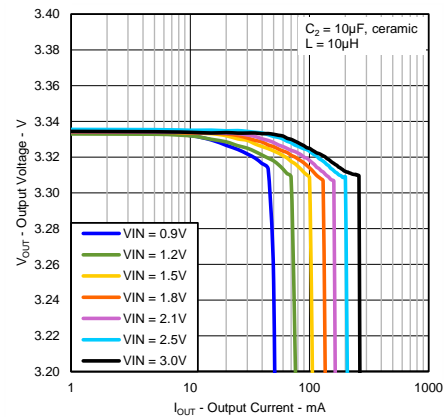

图 10. Output Voltage Ripple

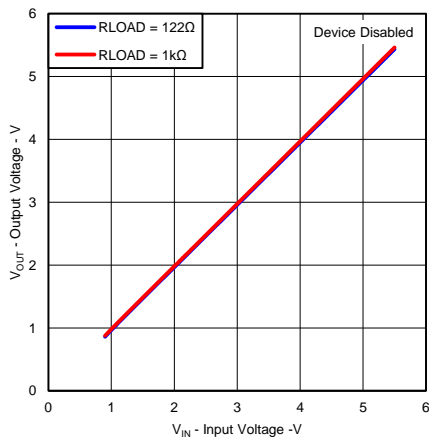

图 11. Load Transient Response

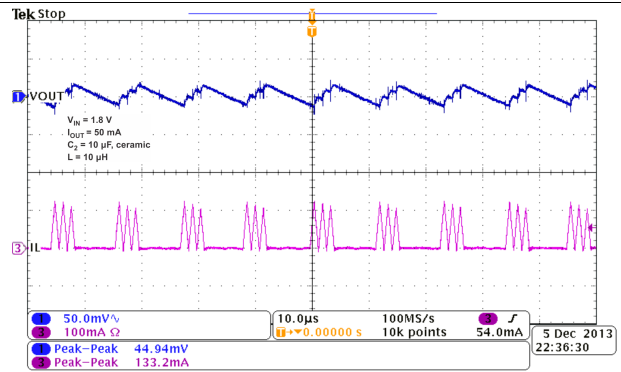

图 12. Line Transient Response

Typical Characteristics (接下页)

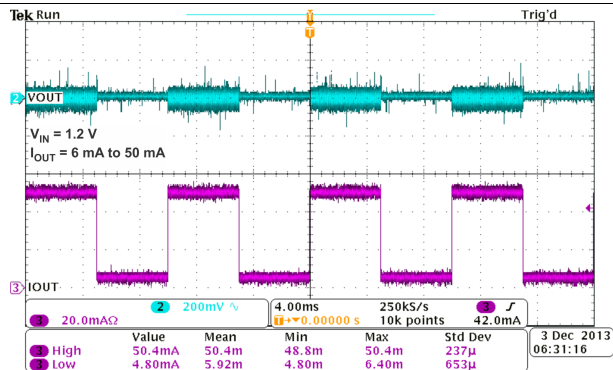

## 7 Parameter Measurement Information

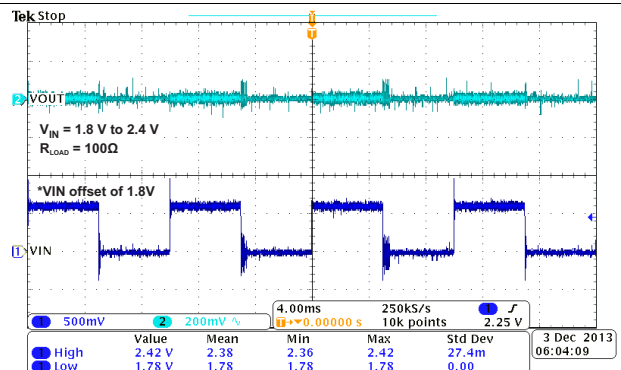
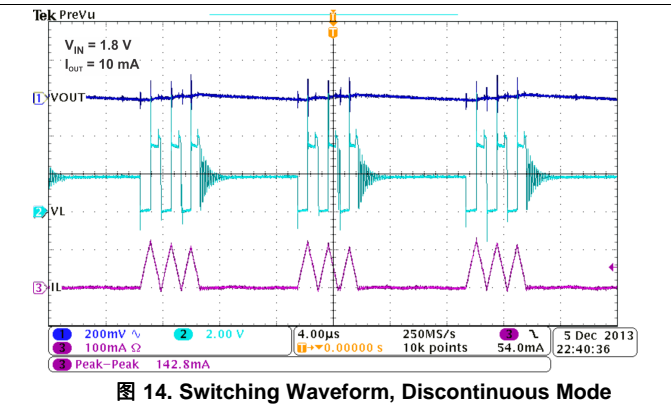
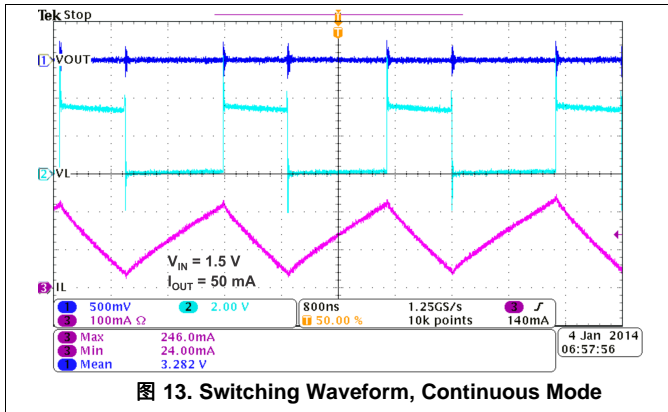

图 15. Measurement Test Circuit

表 1. List of Components

REFERENCE	MANUFACTURER	PART NO.
C2	Murata	GRM319R61A106KE19 10μF 10V X5R 1206 20%
C3	Murata	GRM319R61A106KE19 10μF 10V X5R 1206 20%
L1	Coilcraft	DO3314-103MLC

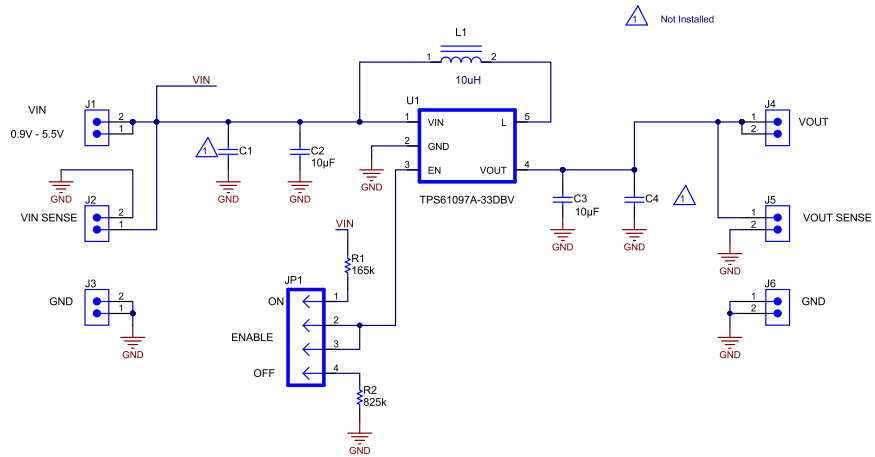

## 8 Detailed Description

### 8.1 Overview

The TPS61097A-33 is a high performance, high efficiency switching boost converter. To achieve high efficiency the power stage is realized as a synchronous boost topology. For the power switching, two actively controlled low  $R_{DSon}$  power MOSFETs are implemented.

### 8.2 Functional Block Diagram

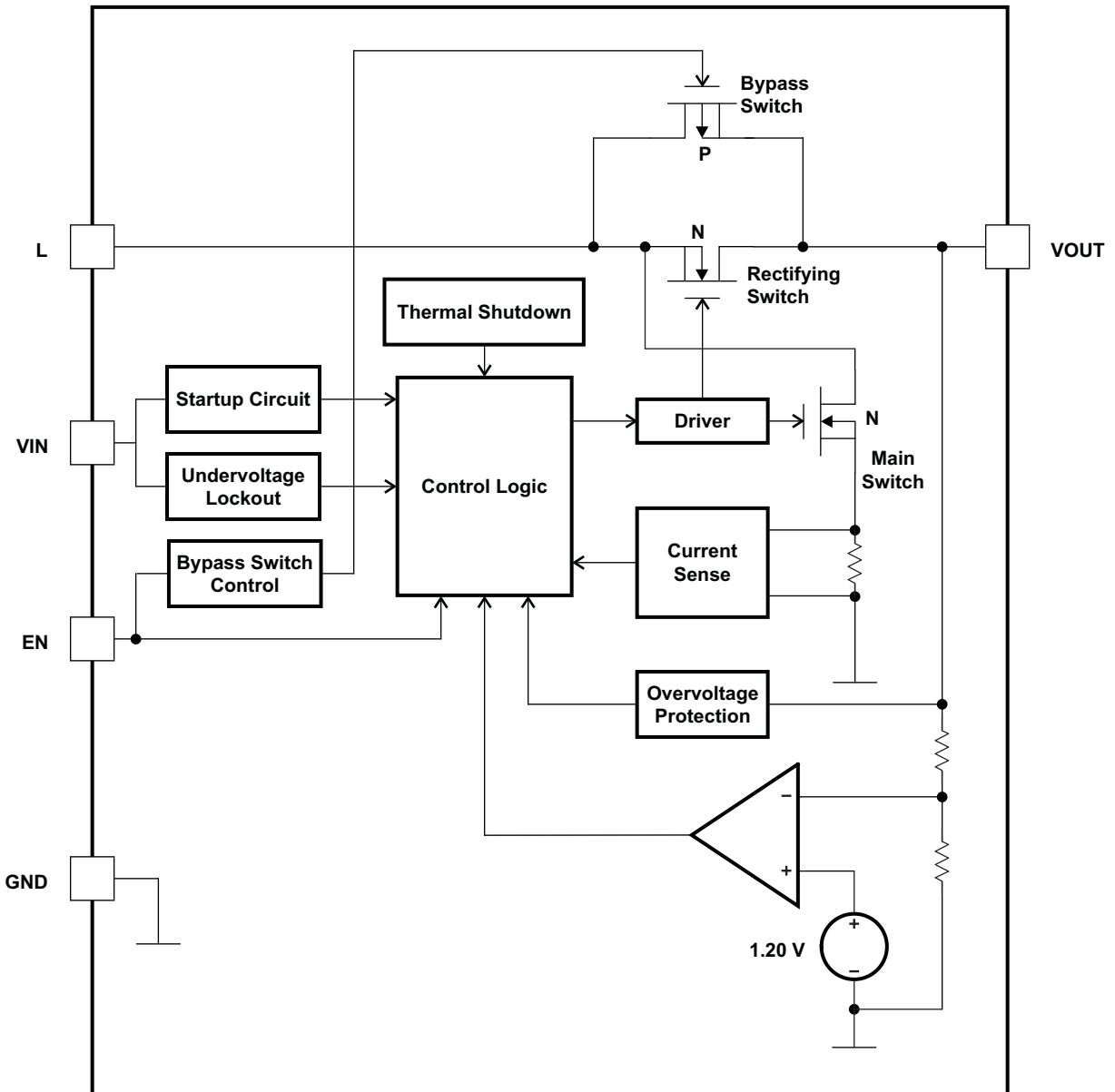

## 8.3 Feature Description

### 8.3.1 Controller Circuit

The device is controlled by a hysteretic current mode controller. This controller regulates the output voltage by keeping the inductor ripple current constant in the range of 200 mA and adjusting the offset of this inductor current depending on the output load. If the required average input current is lower than the average inductor current defined by this constant ripple the inductor current goes discontinuous to keep the efficiency high at low load conditions.

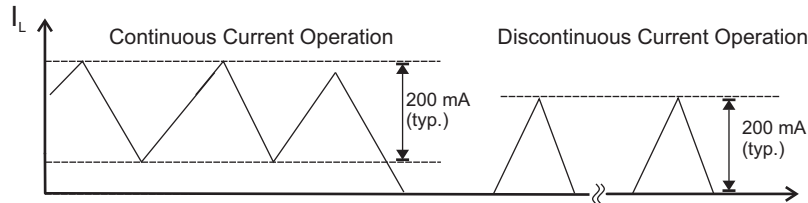

**图 16. Hysteretic Current Operation**

The output voltage  $V_{OUT}$  is monitored via the feedback network which is connected to the voltage error amplifier. To regulate the output voltage, the voltage error amplifier compares this feedback voltage to the internal voltage reference and adjusts the required offset of the inductor current accordingly.

### 8.3.2 Device Enable and Shutdown Mode

The device is enabled when EN is set high and shut down when EN is low. During shutdown, the converter stops switching and all internal control circuitry is turned off.

### 8.3.3 Bypass Switch

The TPS61097A-33 contains a P-channel MOSFET (Bypass Switch) in parallel with the synchronous rectifying MOSFET. When the IC is enabled ( $V_{EN} > V_{IH}$ ), the Bypass Switch is turned off to allow the IC to work as a standard boost converter. When the IC is disabled ( $V_{EN} < V_{IL}$ ) the Bypass Switch is turned on to provide a direct, low impedance connection from the input voltage (at the L pin) to the load (VOUT). The Bypass Switch is not impacted by Undervoltage lockout, Overvoltage or Thermal shutdown.

### 8.3.4 Startup

After the EN pin is tied high, the device starts to operate. If the input voltage is not high enough to supply the control circuit properly a startup oscillator starts to operate the switches. During this phase the switching frequency is controlled by the oscillator and the maximum switch current is limited. As soon as the device has built up the output voltage to about 1.8 V, high enough for supplying the control circuit, the device switches to its normal hysteretic current mode operation. The startup time depends on input voltage and load current.

### 8.3.5 Operation at Output Overload

If in normal boost operation the inductor current reaches the internal switch current limit threshold the main switch is turned off to stop further increase of the input current. In this case the output voltage will decrease since the device can not provide sufficient power to maintain the set output voltage.

If the output voltage drops below the input voltage the backgate diode of the rectifying switch gets forward biased and current starts flow through it. Because this diode cannot be turned off, the load current is only limited by the remaining DC resistances. As soon as the overload condition is removed, the converter automatically resumes normal operation and enters the appropriate soft start mode depending on the operating conditions.

### 8.3.6 Undervoltage Lockout

An undervoltage lockout function stops the operation of the converter if the input voltage drops below the typical undervoltage lockout threshold. This function is implemented in order to prevent malfunctioning of the converter. The undervoltage lockout function has no control of the Bypass Switch. If the Bypass Switch is enabled ( $V_{EN} < V_{IL}$ ) there is no impact during an undervoltage condition, and the Bypass Switch remains on.

## Feature Description (接下页)

### 8.3.7 Overtemperature Protection

The device has a built-in temperature sensor which monitors the internal IC temperature. If the temperature exceeds the programmed threshold (OTP), the device stops operating. As soon as the IC temperature has decreased below the programmed threshold (OTP - OTP<sub>HYST</sub>), it starts operating again. There is a built-in hysteresis to avoid unstable operation at IC temperatures at the overtemperature threshold.

### 8.4 Device Functional Modes

EN	DEVICE STATE
H	Boost Converter
L	Bypass Switch

## 9 Application and Implementation

### 注

Information in the following applications sections is not part of the TI component specification, and TI does not warrant its accuracy or completeness. TI's customers are responsible for determining suitability of components for their purposes. Customers should validate and test their design implementation to confirm system functionality.

### 9.1 Application Information

#### 9.1.1 Adjustable Bypass Switching

The EN pin can be set up as a low voltage control for the bypass switch. By setting the desired ratio of R1 and R2, the TPS61097A-33 can be set to switch on the bypass at a defined voltage level on VIN. For example, setting R1 and R2 to 200 K $\Omega$  would set  $V_{EN}$  to half of VIN. The voltage level of VIN engaging the bypass switch is based on the  $V_{IL}$  level of EN (0.58 V). If VIN is less than 1.16 V then the bypass switch will be enabled. For VIN values above 1.56 V (50% of  $V_{IH}$ ) the bypass switch is disabled.



图 17. Adjustable Bypass Switching

#### 9.1.2 Managing Inrush Current

Upon startup, the output capacitor of the boost converter can act as a virtual short circuit. The amount of inrush current is dependent on the rate of increase of the input voltage, the inductance used with the converter, the output capacitance and the parasitic circuit resistance. One method to reduce the inrush current is to use a load switch with controlled turn-on. Texas Instruments has a large offering of controlled slew rate load switches which can be found at [www.ti.com/loadswitches](http://www.ti.com/loadswitches). Below is an example circuit that has a load switch with controlled turn-on.

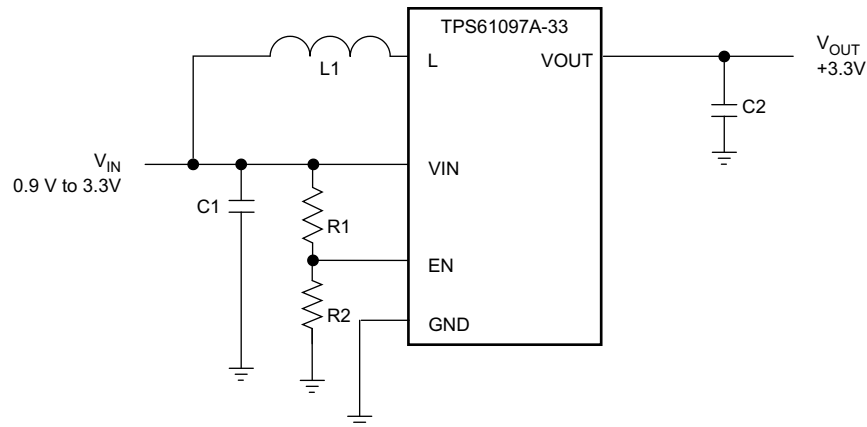

图 18. Example Circuit with Load Switch

## Application Information (接下页)

### 9.1.3 Thermal Considerations

Implementation of integrated circuits in low-profile and fine-pitch surface-mount packages typically requires special attention to power dissipation. Many system-dependent issues such as thermal coupling, airflow, added heat sinks and convection surfaces, and the presence of other heat-generating components affect the power-dissipation limits of a given component.

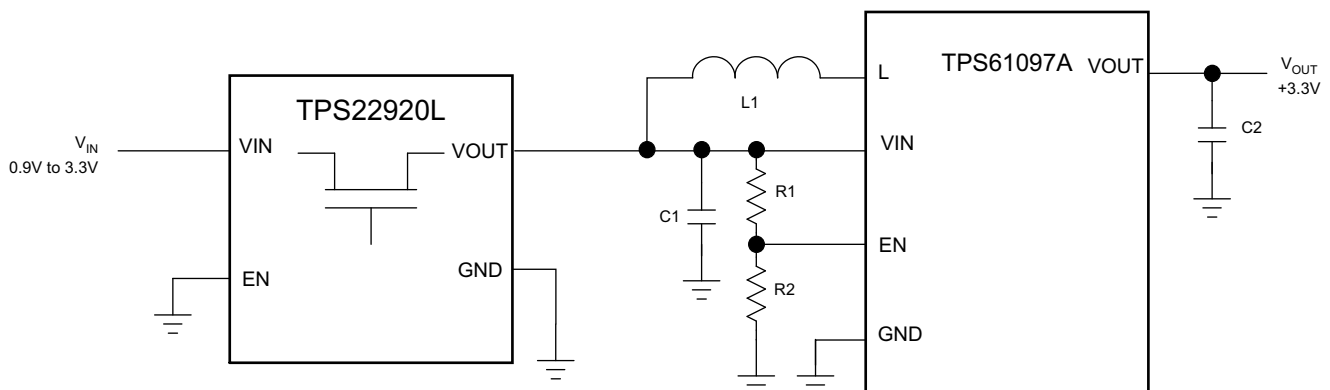
Three basic approaches for enhancing thermal performance are listed below.

- Improving the power dissipation capability of the PCB design
- Improving the thermal coupling of the component to the PCB
- Introducing airflow in the system

The maximum recommended junction temperature ( $T_J$ ) of the TPS61097A-33 devices is 125°C. Specified regulator operation is assured to a maximum ambient temperature  $T_A$  of 85°C. Therefore, the maximum power dissipation is about 191.7 mW. More power can be dissipated if the maximum ambient temperature of the application is lower.

## 9.2 Typical Application



图 19. Typical Application Schematic

### 9.2.1 Design Requirements

DESIGN PARAMETERS	EXAMPLE VALUE
Input Voltage ( $V_{IN}$ )	1.2 V to 1.8 V
Output Voltage ( $V_{OUT}$ )	3.3 V
Output Current ( $I_{OUT}$ )	10 mA

### 9.2.2 Detailed Design Procedure

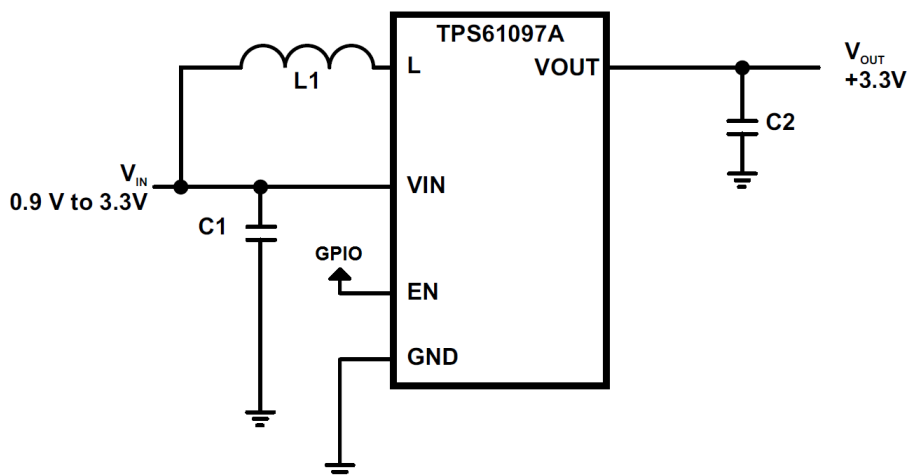
#### 9.2.2.1 Inductor Selection

To make sure that the TPS61097A-33 devices can operate, a suitable inductor must be connected between pin VIN and pin L. Inductor values of 4.7  $\mu$ H show good performance over the whole input and output voltage range .

Choosing other inductance values affects the switching frequency  $f$  proportional to  $1/L$  as shown in [公式 1](#).

$$L = \frac{1}{f \times 200 \text{ mA}} \times \frac{V_{IN} \times (V_{OUT} - V_{IN})}{V_{OUT}} \quad (1)$$

Choosing inductor values higher than 4.7  $\mu\text{H}$  can improve efficiency due to reduced switching frequency and therefore with reduced switching losses. Using inductor values below 2.2  $\mu\text{H}$  is not recommended.

Having selected an inductance value, the peak current for the inductor in steady state operation can be calculated. 公式 2 gives the peak current estimate.

$$I_{L,MAX} = \begin{cases} \frac{V_{OUT} \times I_{OUT}}{0.8 \times V_{IN}} + 100 \text{ mA}; & \text{continuous current operation} \\ 200 \text{ mA}; & \text{discontinuous current operation} \end{cases} \quad (2)$$

$I_{L,MAX}$  is the inductor's required minimum current rating. Note that load transient or over current conditions may require an even higher current rating.

公式 3 provides an easy way to estimate whether the device is operating in continuous or discontinuous operation. As long as the equation is true, continuous operation is typically established. If the equation becomes false, discontinuous operation is typically established.

$$\frac{V_{OUT} \times I_{OUT}}{V_{IN}} > 0.8 \times 100 \text{ mA} \quad (3)$$

Due to the use of current hysteretic control in the TPS61097A-33, the series resistance of the inductor can impact the operation of the main switch. There is a simple calculation that can ensure proper operation of the TPS61097A-33 boost converter. The relationship between the series resistance ( $R_{IN}$ ), the input voltage ( $V_{IN}$ ) and the switch current limit ( $I_{SW}$ ) is shown in 公式 4.

$$R_{IN} < V_{IN} / I_{SW} \quad (4)$$

Examples:

$$I_{SW} = 400 \text{ mA}, V_{IN} = 2.5 \text{ V} \quad (5)$$

In 公式 5,  $R_{IN} < 2.5 \text{ V} / 400 \text{ mA}$ ; therefore,  $R_{IN}$  must be less than 6.25  $\Omega$ .

$$I_{SW} = 400 \text{ mA}, V_{IN} = 1.8 \text{ V} \quad (6)$$

In 公式 6,  $R_{IN} < 1.8 \text{ V} / 400 \text{ mA}$ ; therefore,  $R_{IN}$  must be less than 4.5  $\Omega$ .

The following inductor series from different suppliers have been used with TPS61097A-33 converters:

**表 2. List of Inductors**

VENDOR	INDUCTOR SERIES
Coilcraft	DO3314
TDK	NLC565050T
Taiyo Yuden	CBC2012T

## 9.2.2.2 Capacitor Selection

### 9.2.2.2.1 Input Capacitor

The input capacitor should be at least 10- $\mu\text{F}$  to improve transient behavior of the regulator and EMI behavior of the total power supply circuit. The input capacitor should be a ceramic capacitor and be placed as close as possible to the VIN and GND pins of the IC.

### 9.2.2.2.2 Output Capacitor

For the output capacitor  $C_2$ , it is recommended to use small ceramic capacitors placed as close as possible to the VOUT and GND pins of the IC. If, for any reason, the application requires the use of large capacitors which can not be placed close to the IC, the use of a small ceramic capacitor with a capacitance value of around 2.2  $\mu\text{F}$  in parallel to the large one is recommended. This small capacitor should be placed as close as possible to the VOUT and GND pins of the IC.

A minimum capacitance value of 4.7  $\mu\text{F}$  should be used, 10  $\mu\text{F}$  are recommended. If the inductor exceeds 4.7  $\mu\text{H}$ , the value of the output capacitance value needs to be half the inductance value or higher for stability reasons, see 公式 7.

$$C_2 \geq \frac{L}{2} \times \frac{\mu F}{\mu H} \tag{7}$$

Using low ESR capacitors, such as ceramic capacitors, is recommended to minimize output voltage ripple. If heavy load changes are expected, the output capacitor value should be increased to avoid output voltage drops during fast load transients.

表 3. Recommended Output Capacitors

VENDOR	CAPACITOR SERIES
Murata	GRM188R60J106M47D 10μF 6.3V X5R 0603
Murata	GRM319R61A106KE19 10μF 10V X5R 1206

9.2.3 Application Curves

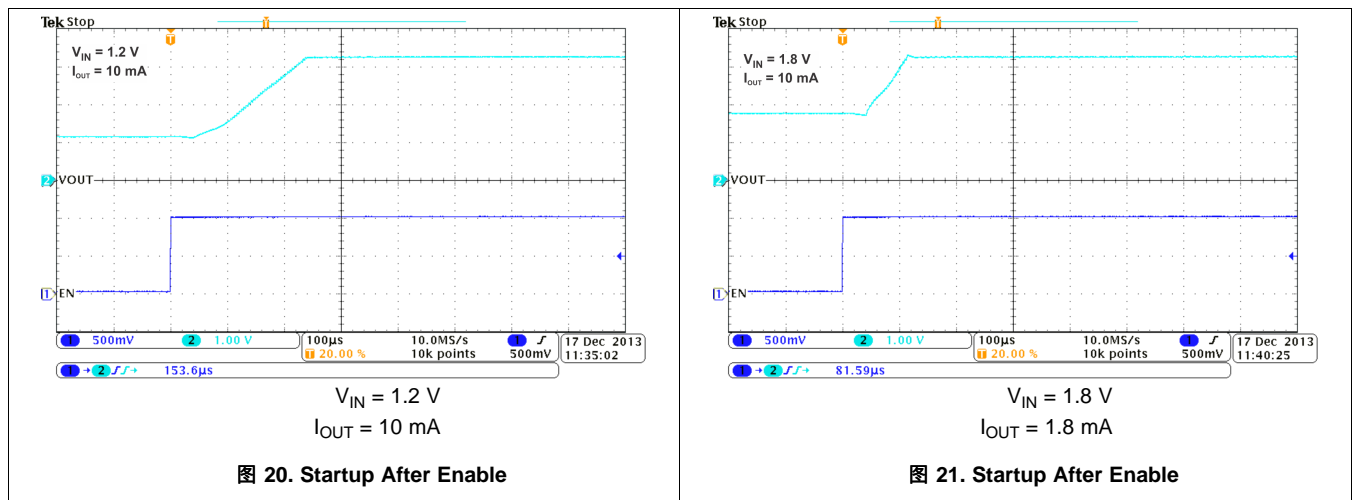

## 10 Power Supply Recommendations

The TPS61097A-33 DC-DC converters are intended for systems powered by a single up to triple cell Alkaline, NiCd, NiMH battery with a typical terminal voltage between 0.9 V and 5.5 V. They can also be used in systems powered by one-cell Li-Ion or Li-Polymer with a typical voltage between 2.5 V and 4.2 V. Additionally, any other voltage source like solar cells or fuel cells with a typical output voltage between 0.9 V and 5.5 V can power systems where the TPS61097A-33 is used. The TPS61097A-33 does not down-regulate  $V_{IN}$ ; therefore, if  $V_{IN}$  is greater than  $V_{OUT}$ ,  $V_{OUT}$  tracks  $V_{IN}$ .

## 11 Layout

### 11.1 Layout Guidelines

As for all switching power supplies, the layout is an important step in the design, especially at high peak currents and high switching frequencies. If the layout is not carefully done, the regulator could show stability problems as well as EMI problems. Therefore, use wide and short traces for the main current path and for the power ground tracks. The input and output capacitor, as well as the inductor should be placed as close as possible to the IC. Use a common ground node for power ground and a different one for control ground to minimize the effects of ground noise. Connect these ground nodes at any place close to one of the ground pins of the IC.

The feedback divider should be placed as close as possible to the control ground pin of the IC. To lay out the control ground, it is recommended to use short traces as well, separated from the power ground traces. This avoids ground shift problems, which can occur due to superimposition of power ground current and control ground current.

### 11.2 Layout Example



图 22. Layout Example



## 12 器件和文档支持

### 12.1 器件支持

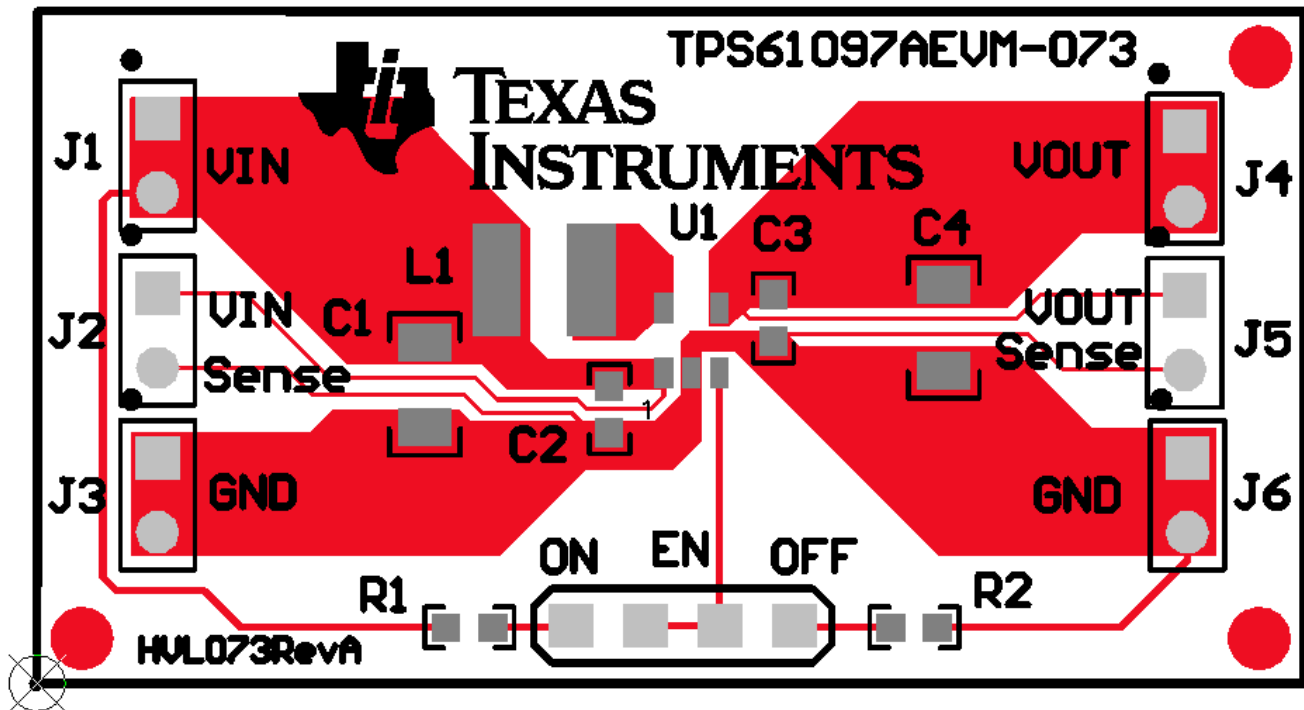
#### 12.1.1 第三方产品免责声明

TI 发布的与第三方产品或服务有关的信息，不能构成与此类产品或服务或保修的适用性有关的认可，不能构成此类产品或服务单独或与任何 TI 产品或服务一起的表示或认可。

### 12.2 商标

All trademarks are the property of their respective owners.

### 12.3 静电放电警告



这些装置包含有限的内置 ESD 保护。存储或装卸时，应将导线一起截短或将装置放置于导电泡棉中，以防止 MOS 门极遭受静电损伤。

### 12.4 术语表

[SLYZ022](#) — TI 术语表。

这份术语表列出并解释术语、首字母缩略词和定义。

## 13 机械封装和可订购信息

以下页中包括机械封装和可订购信息。 这些信息是针对指定器件可提供的最新数据。 这些数据会在无通知且不对本文档进行修订的情况下发生改变。 欲获得该数据表的浏览器版本，请查阅左侧的导航栏。

**PACKAGING INFORMATION**

Orderable Device	Status (1)	Package Type	Package Drawing	Pins	Package Qty	Eco Plan (2)	Lead finish/ Ball material (6)	MSL Peak Temp (3)	Op Temp (°C)	Device Marking (4/5)	Samples
TPS61097A-33DBVR	ACTIVE	SOT-23	DBV	5	3000	RoHS & Green	NIPDAU   SN	Level-1-260C-UNLIM	-40 to 125	(NG5F, NG5K)	<a href="#">Samples</a>
TPS61097A-33DBVT	ACTIVE	SOT-23	DBV	5	250	RoHS & Green	NIPDAU	Level-1-260C-UNLIM	-40 to 125	NG5K	<a href="#">Samples</a>

(1) The marketing status values are defined as follows:

**ACTIVE:** Product device recommended for new designs.

**LIFEBUY:** TI has announced that the device will be discontinued, and a lifetime-buy period is in effect.

**NRND:** Not recommended for new designs. Device is in production to support existing customers, but TI does not recommend using this part in a new design.

**PREVIEW:** Device has been announced but is not in production. Samples may or may not be available.

**OBSOLETE:** TI has discontinued the production of the device.

(2) **RoHS:** TI defines "RoHS" to mean semiconductor products that are compliant with the current EU RoHS requirements for all 10 RoHS substances, including the requirement that RoHS substance do not exceed 0.1% by weight in homogeneous materials. Where designed to be soldered at high temperatures, "RoHS" products are suitable for use in specified lead-free processes. TI may reference these types of products as "Pb-Free".

**RoHS Exempt:** TI defines "RoHS Exempt" to mean products that contain lead but are compliant with EU RoHS pursuant to a specific EU RoHS exemption.

**Green:** TI defines "Green" to mean the content of Chlorine (Cl) and Bromine (Br) based flame retardants meet JS709B low halogen requirements of <=1000ppm threshold. Antimony trioxide based flame retardants must also meet the <=1000ppm threshold requirement.

(3) MSL, Peak Temp. - The Moisture Sensitivity Level rating according to the JEDEC industry standard classifications, and peak solder temperature.

(4) There may be additional marking, which relates to the logo, the lot trace code information, or the environmental category on the device.

(5) Multiple Device Markings will be inside parentheses. Only one Device Marking contained in parentheses and separated by a "~" will appear on a device. If a line is indented then it is a continuation of the previous line and the two combined represent the entire Device Marking for that device.

(6) Lead finish/Ball material - Orderable Devices may have multiple material finish options. Finish options are separated by a vertical ruled line. Lead finish/Ball material values may wrap to two lines if the finish value exceeds the maximum column width.

**Important Information and Disclaimer:**The information provided on this page represents TI's knowledge and belief as of the date that it is provided. TI bases its knowledge and belief on information provided by third parties, and makes no representation or warranty as to the accuracy of such information. Efforts are underway to better integrate information from third parties. TI has taken and continues to take reasonable steps to provide representative and accurate information but may not have conducted destructive testing or chemical analysis on incoming materials and chemicals. TI and TI suppliers consider certain information to be proprietary, and thus CAS numbers and other limited information may not be available for release.

In no event shall TI's liability arising out of such information exceed the total purchase price of the TI part(s) at issue in this document sold by TI to Customer on an annual basis.



## TAPE AND REEL INFORMATION



### QUADRANT ASSIGNMENTS FOR PIN 1 ORIENTATION IN TAPE



\*All dimensions are nominal

Device	Package Type	Package Drawing	Pins	SPQ	Reel Diameter (mm)	Reel Width W1 (mm)	A0 (mm)	B0 (mm)	K0 (mm)	P1 (mm)	W (mm)	Pin1 Quadrant
TPS61097A-33DBVT	SOT-23	DBV	5	250	180.0	8.4	3.23	3.17	1.37	4.0	8.0	Q3

**TAPE AND REEL BOX DIMENSIONS**

\*All dimensions are nominal

Device	Package Type	Package Drawing	Pins	SPQ	Length (mm)	Width (mm)	Height (mm)
TPS61097A-33DBVT	SOT-23	DBV	5	250	183.0	183.0	20.0

# DBV0005A



# PACKAGE OUTLINE

## SOT-23 - 1.45 mm max height

SMALL OUTLINE TRANSISTOR

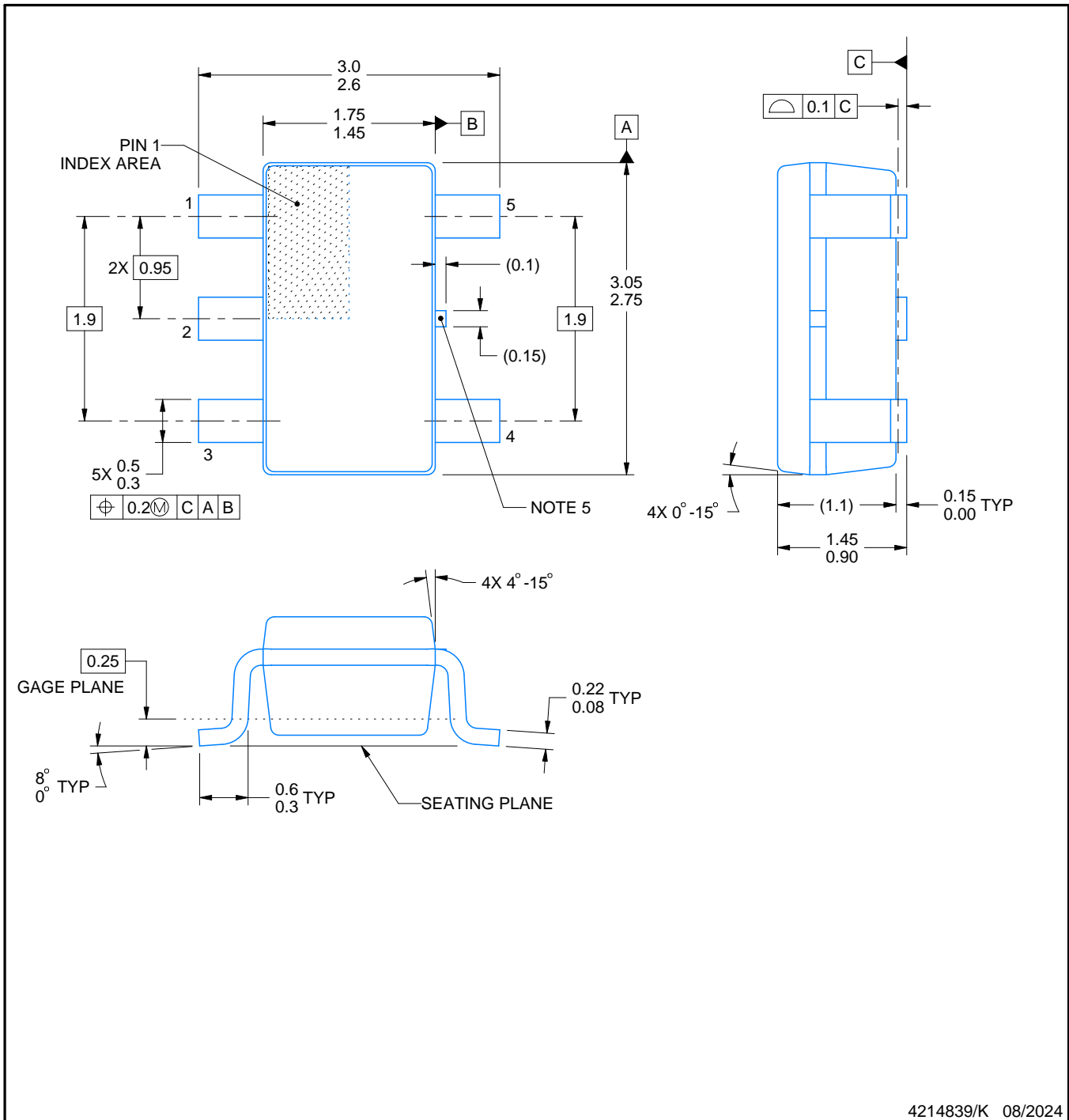

4214839/K 08/2024

### NOTES:

1. All linear dimensions are in millimeters. Any dimensions in parenthesis are for reference only. Dimensioning and tolerancing per ASME Y14.5M.
2. This drawing is subject to change without notice.
3. Reference JEDEC MO-178.
4. Body dimensions do not include mold flash, protrusions, or gate burrs. Mold flash, protrusions, or gate burrs shall not exceed 0.25 mm per side.
5. Support pin may differ or may not be present.

# EXAMPLE BOARD LAYOUT

DBV0005A

SOT-23 - 1.45 mm max height

SMALL OUTLINE TRANSISTOR



LAND PATTERN EXAMPLE  
EXPOSED METAL SHOWN  
SCALE:15X



SOLDER MASK DETAILS

4214839/K 08/2024

NOTES: (continued)

- 6. Publication IPC-7351 may have alternate designs.
- 7. Solder mask tolerances between and around signal pads can vary based on board fabrication site.

# EXAMPLE STENCIL DESIGN

DBV0005A

SOT-23 - 1.45 mm max height

SMALL OUTLINE TRANSISTOR

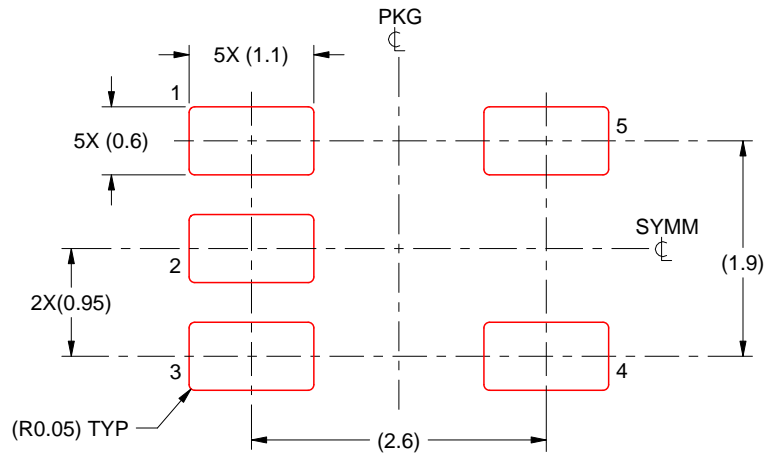

SOLDER PASTE EXAMPLE  
BASED ON 0.125 mm THICK STENCIL  
SCALE:15X

4214839/K 08/2024

NOTES: (continued)

8. Laser cutting apertures with trapezoidal walls and rounded corners may offer better paste release. IPC-7525 may have alternate design recommendations.
9. Board assembly site may have different recommendations for stencil design.



## 重要声明和免责声明

TI“按原样”提供技术和可靠性数据（包括数据表）、设计资源（包括参考设计）、应用或其他设计建议、网络工具、安全信息和其他资源，不保证没有瑕疵且不做任何明示或暗示的担保，包括但不限于对适销性、某特定用途方面的适用性或不侵犯任何第三方知识产权的暗示担保。

这些资源可供使用 TI 产品进行设计的熟练开发人员使用。您将自行承担以下全部责任：(1) 针对您的应用选择合适的 TI 产品，(2) 设计、验证并测试您的应用，(3) 确保您的应用满足相应标准以及任何其他功能安全、信息安全、监管或其他要求。

这些资源如有变更，恕不另行通知。TI 授权您仅可将这些资源用于研发本资源所述的 TI 产品的应用。严禁对这些资源进行其他复制或展示。您无权使用任何其他 TI 知识产权或任何第三方知识产权。您应全额赔偿因在这些资源的使用中对 TI 及其代表造成的任何索赔、损害、成本、损失和债务，TI 对此概不负责。

TI 提供的产品受 [TI 的销售条款](#) 或 [ti.com](#) 上其他适用条款/TI 产品随附的其他适用条款的约束。TI 提供这些资源并不会扩展或以其他方式更改 TI 针对 TI 产品发布的适用的担保或担保免责声明。

TI 反对并拒绝您可能提出的任何其他或不同的条款。

邮寄地址：Texas Instruments, Post Office Box 655303, Dallas, Texas 75265  
Copyright © 2024，德州仪器 (TI) 公司