

## TPS6301x Highly Efficient, Single Inductor Buck-Boost Converter With 2-A Switches

### 1 Features

- Up to 96% Efficiency
- 1200-mA Output Current at 3.3 V in Step-Down Mode ( $V_{IN} = 3.6\text{ V to }5.5\text{ V}$ )
- Up to 800-mA Output Current at 3.3 V in Boost Mode ( $V_{IN} > 2.4\text{ V}$ )
- Automatic Transition Between Step-Down and Boost Mode
- Device Quiescent Current less than 50  $\mu\text{A}$
- Input Voltage Range: 2 V to 5.5 V
- Fixed and Adjustable Output Voltage Options from 1.2 V to 5.5 V
- Power Save Mode for Improved Efficiency at Low-Output Power
- Forced Fixed Frequency Operation and Synchronization Possible
- Load Disconnect During Shutdown
- Output Overvoltage Protection
- Overtemperature Protection
- Available in Small 20-Pin, 2.126 mm  $\times$  1.922 mm, DSBGA Package

### 2 Applications

- All Two-Cell and Three-Cell Alkaline, NiCd or NiMH, or Single-Cell Li Battery-Powered Products
- Portable Audio Players
- PDAs
- Cellular Phones
- Personal Medical Products
- White LEDs

### 3 Description

The TPS6301x devices provide a power supply solution for products powered by either a two-cell or three-cell alkaline, NiCd or NiMH battery, or a one-cell Li-Ion or Li-polymer battery. Output currents can go as high as 1200 mA while using a single-cell Li-Ion or Li-Polymer Battery, and discharge it down to 2.5 V or lower. The buck-boost converter is based on a fixed-frequency, pulse-width-modulation (PWM) controller using synchronous rectification to obtain maximum efficiency. At low load currents, the converter enters power save mode to maintain high efficiency over a wide load current range. The power save mode can be disabled, forcing the converter to operate at a fixed switching frequency. The maximum average current in the switches is limited to a typical value of 2200 mA. The output voltage is programmable using an external resistor divider, or is fixed internally on the chip. The converter can be disabled to minimize battery drain. During shutdown, the load is disconnected from the battery. The device is packaged in a 20-pin DSBGA package measuring 2.126 mm  $\times$  1.922 mm (YFF).

#### Device Information<sup>(1)</sup>

PART NUMBER	PACKAGE	BODY SIZE (NOM)
TPS6301x	DSBGA (20)	2.126 mm $\times$ 1.922 mm

(1) For all available packages, see the orderable addendum at the end of the data sheet.

#### Typical Application Circuit

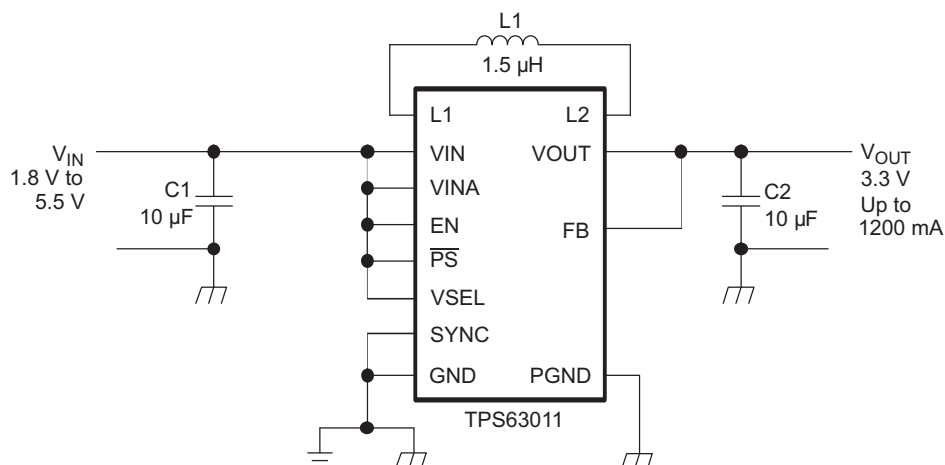

## Table of Contents

<b>1 Features</b> .....	<b>1</b>	8.4 Device Functional Modes.....	<b>13</b>
<b>2 Applications</b> .....	<b>1</b>	<b>9 Application and Implementation</b> .....	<b>15</b>
<b>3 Description</b> .....	<b>1</b>	9.1 Application Information.....	<b>15</b>
<b>4 Revision History</b> .....	<b>2</b>	9.2 Typical Application .....	<b>15</b>
<b>5 Device Comparison Table</b> .....	<b>3</b>	<b>10 Power Supply Recommendations</b> .....	<b>19</b>
<b>6 Pin Configuration and Functions</b> .....	<b>3</b>	<b>11 Layout</b> .....	<b>19</b>
<b>7 Specifications</b> .....	<b>4</b>	11.1 Layout Guidelines .....	<b>19</b>
7.1 Absolute Maximum Ratings .....	<b>4</b>	11.2 Layout Example .....	<b>19</b>
7.2 ESD Ratings.....	<b>4</b>	11.3 Thermal Consideration.....	<b>20</b>
7.3 Recommended Operating Conditions.....	<b>4</b>	<b>12 Device and Documentation Support</b> .....	<b>21</b>
7.4 Thermal Information .....	<b>4</b>	12.1 Related Links .....	<b>21</b>
7.5 Electrical Characteristics.....	<b>5</b>	12.2 Community Resources.....	<b>21</b>
7.6 Dissipation Ratings .....	<b>6</b>	12.3 Trademarks .....	<b>21</b>
7.7 Typical Characteristics .....	<b>7</b>	12.4 Electrostatic Discharge Caution.....	<b>21</b>
<b>8 Detailed Description</b> .....	<b>11</b>	12.5 Glossary .....	<b>21</b>
8.1 Overview .....	<b>11</b>	<b>13 Mechanical, Packaging, and Orderable</b>	
8.2 Functional Block Diagrams .....	<b>11</b>	<b>Information</b> .....	<b>21</b>
8.3 Feature Description.....	<b>12</b>	13.1 Package Dimensions .....	<b>21</b>

## 4 Revision History

NOTE: Page numbers for previous revisions may differ from page numbers in the current version.

<b>Changes from Revision B (May 2012) to Revision C</b>	<b>Page</b>
<ul style="list-style-type: none"> <li>Added ESD Ratings table, Feature Description section, Device Functional Modes, Application and Implementation section, Power Supply Recommendations section, Layout section, Device and Documentation Support section, and Mechanical, Packaging, and Orderable Information section. ....</li> </ul>	<b>1</b>

<b>Changes from Revision A (August 2009) to Revision B</b>	<b>Page</b>
<ul style="list-style-type: none"> <li>Changed the YFF Package Dimensions table .....</li> </ul>	<b>21</b>

<b>Changes from Original (June 2008) to Revision A</b>	<b>Page</b>
<ul style="list-style-type: none"> <li>Changed Title From: High Efficient... To: Highly Efficient... ..</li> <li>Added Feature - Output Overvoltage Protection .....</li> <li>Added Output overvoltage protection to the CONTROL STAGE ELECTRICAL CHARACTERISTICS.....</li> <li>Added Overvoltage Protection section .....</li> <li>Changed Sentence in the PROGRAMMING THE OUTPUT VOLTAGE section - From: As an example, if an output voltage of 3.3 V is needed, a 1-M<math>\Omega</math> resistor should be chosen for R1. To: As an example, if an output voltage of 3.3 V is needed, a 1-M<math>\Omega</math> resistor should be chosen for R1 if R2 is 180-k<math>\Omega</math> .....</li> <li>Added Figure - PCB Layout Suggestion .....</li> </ul>	<b>19</b>

## 5 Device Comparison Table

**Table 1. Available Output Voltage Options<sup>(1)</sup>**

$T_A$	OUTPUT VOLTAGE DC/DC at VSEL = 1	OUTPUT VOLTAGE DC/DC at VSEL = 0	PACKAGE MARKING	PACKAGE	PART NUMBER <sup>(2)</sup>
–40°C to 85°C	Adjustable	Adjustable	TPS63010	20-Pin WCSP	TPS63010YFF
	3.3 V	2.8 V	TPS63011		TPS63011YFF
	3.4 V	2.9 V	TPS63012		TPS63012YFF

(1) Contact the factory to check availability of other fixed output voltage versions.

(2) The YFF package is available taped and reeled. Add R suffix to device type (for example, TPS63010YFFR) to order quantities of 3000 devices per reel. Add T suffix to device type (for example, TPS63010YFFT) to order quantities of 250 devices per reel.

## 6 Pin Configuration and Functions

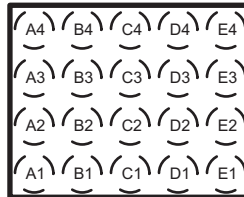
**YFF Package  
20-Pin DSBGA  
Top View**

### Pin Functions

PIN		I/O	DESCRIPTION
NAME	NO.		
EN	A4	I	Enable input. (1 enabled, 0 disabled)
FB	E3	I	Voltage feedback of adjustable versions, must be connected to VOUT at fixed output voltage versions
GND	C3, D3, E4	—	Control and logic ground
L1	B1,B2	I	Connection for Inductor
L2	D1,D2	I	Connection for Inductor
PGND	C1,C2	—	Power ground
$\overline{PS}$	C4	I	Enable and disable power save mode (1 disabled, 0 enabled)
SYNC	B4	I	Clock signal for synchronization, should be connected to GND if not used
VIN	A1, A2	I	Supply voltage for power stage
VINA	A3	I	Supply voltage for control stage
VINA1	B3	O	Output of the 100 $\Omega$ for designing the VINA filter
VOUT	E1,E2	O	Buck-boost converter output
VSEL	D4	I	Output voltage select for fixed output voltage options (1 programs higher output voltage option, 0 programs lower output voltage option), must be connected to a defined logic signal at adjustable output voltage option.

## 7 Specifications

### 7.1 Absolute Maximum Ratings

over operating free-air temperature range (unless otherwise noted)<sup>(1)</sup>

		MIN	MAX	UNIT
$V_I$	Input voltage on VIN, VINA, VINA1, L1, L2, VOUT, $\overline{PS}$ , SYNC, VSEL, EN, FB	-0.3	7	V
$T_J$	Operating junction temperature	-40	150	°C
$T_{stg}$	Storage temperature	-65	150	°C

(1) Stresses beyond those listed under *Absolute Maximum Ratings* may cause permanent damage to the device. These are stress ratings only, and functional operation of the device at these or any other conditions beyond those indicated under *Recommended Operating Conditions* is not implied. Exposure to absolute-maximum-rated conditions for extended periods may affect device reliability.

### 7.2 ESD Ratings

		VALUE	UNIT
$V_{(ESD)}$	Electrostatic discharge	Human-body model (HBM), per ANSI/ESDA/JEDEC JS-001 <sup>(1)(2)</sup>	±2500
		Charged-device model (CDM), per JEDEC specification JESD22-C101 <sup>(3)(2)</sup>	±150
		Machine model (MM) <sup>(2)</sup>	±1000

(1) JEDEC document JEP155 states that 500-V HBM allows safe manufacturing with a standard ESD control process.

(2) ESD testing is performed according to the respective JESD22 JEDEC standard.

(3) JEDEC document JEP157 states that 250-V CDM allows safe manufacturing with a standard ESD control process.

### 7.3 Recommended Operating Conditions

over operating free-air temperature range (unless otherwise noted)

	MIN	MAX	UNIT
Supply voltage at VIN, VINA	2	5.5	V
Operating free air temperature, $T_A$	-40	85	°C
Operating junction temperature, $T_J$	-40	125	°C

### 7.4 Thermal Information

THERMAL METRIC <sup>(1)</sup>	TPS6301x	UNIT	
	YFF (DSBGA)		
	20 PINS		
$R_{\theta JA}$	Junction-to-ambient thermal resistance	71.1	°C/W
$R_{\theta JC(top)}$	Junction-to-case (top) thermal resistance	0.5	°C/W
$R_{\theta JB}$	Junction-to-board thermal resistance	11.4	°C/W
$\Psi_{JT}$	Junction-to-top characterization parameter	2	°C/W
$\Psi_{JB}$	Junction-to-board characterization parameter	11.3	°C/W
$R_{\theta JC(bot)}$	Junction-to-case (bottom) thermal resistance	N/A	°C/W

(1) For more information about traditional and new thermal metrics, see the *Semiconductor and IC Package Thermal Metrics* application report, [SPRA953](#).

## 7.5 Electrical Characteristics

over recommended free-air temperature range and over recommended input voltage range (typical at an ambient temperature range of 25°C) (unless otherwise noted)

PARAMETER		TEST CONDITIONS	MIN	TYP	MAX	UNIT
<b>DC-DC STAGE</b>						
$V_I$	Input voltage range		2		5.5	V
$V_I$	Input voltage range for start-up		2.1		5.5	V
$V_O$	TPS63010 output voltage range		1.2		5.5	V
$V_{FB}$	TPS63010 feedback voltage	$0^\circ\text{C} \leq T_A \leq 60^\circ\text{C}$	492.5	500	503.5	mV
$V_{FB}$	TPS63010 feedback voltage		489	500	507	mV
	TPS63011 output voltage	VSEL = LOW, $0^\circ\text{C} \leq T_A \leq 60^\circ\text{C}$	2.758	2.8	2.842	V
	TPS63011 output voltage	VSEL = LOW	2.75	2.8	2.85	V
	TPS63011 output voltage	VSEL = HIGH, $0^\circ\text{C} \leq T_A \leq 60^\circ\text{C}$	3.251	3.3	3.35	V
	TPS63011 output voltage	VSEL = HIGH	3.241	3.3	3.359	V
	TPS63012 output voltage	VSEL = LOW, $0^\circ\text{C} \leq T_A \leq 60^\circ\text{C}$	2.857	2.9	2.944	V
	TPS63012 output voltage	VSEL = LOW	2.848	2.9	2.952	V
	TPS63012 output voltage	VSEL = HIGH, $0^\circ\text{C} \leq T_A \leq 60^\circ\text{C}$	3.349	3.4	3.451	V
	TPS63012 output voltage	VSEL = HIGH	3.339	3.4	3.461	V
f	Oscillator frequency		2200	2400	2600	kHz
	Frequency range for synchronization		2200		3000	kHz
$I_{SW}$	Switch current limit	$V_{IN} = V_{INA} = 3.6\text{ V}$ , $T_A = 25^\circ\text{C}$	2000	2200	2400	mA
	High side switch on resistance	$V_{IN} = V_{INA} = 3.6\text{ V}$		100		m $\Omega$
	Low side switch on resistance	$V_{IN} = V_{INA} = 3.6\text{ V}$		100		m $\Omega$
	Maximum line regulation	$\overline{PS} = \text{HIGH}$		0.5%		
	Maximum load regulation	$\overline{PS} = \text{HIGH}$		0.5%		
$I_q$	Quiescent current	VIN		1	2	$\mu\text{A}$
		VINA		40	50	$\mu\text{A}$
		VOUT (adjustable output voltage version)	$I_O = 0\text{ mA}$ , $V_{EN} = V_{IN} = V_{INA} = 3.6\text{ V}$ , $V_{OUT} = 3.3\text{ V}$		4	6
	FB input impedance (fixed output voltage versions)			1		M $\Omega$
$I_S$	Shutdown current	VIN	$V_{EN} = 0\text{ V}$ , $V_{IN} = V_{INA} = 3.6\text{ V}$	0.1	1	$\mu\text{A}$
		VINA	$\overline{PS}$ , SYNC, VSEL clamped on GND or VINA	0.1	1.5	$\mu\text{A}$
<b>CONTROL STAGE</b>						
UVLO	Undervoltage lockout threshold	$V_{INA}$ voltage decreasing	1.5	1.7	1.8	V
$V_{IL}$	EN, $\overline{PS}$ , SYNC, VSEL input low voltage				0.4	V
$V_{IH}$	EN, $\overline{PS}$ , SYNC, VSEL input high voltage		1.2			V
	EN, $\overline{PS}$ , SYNC, VSEL input current	Clamped on GND or VINA		0.01	0.1	$\mu\text{A}$
	Output overvoltage protection			6.5		V
	Overtemperature protection			140		$^\circ\text{C}$
	Overtemperature hysteresis			20		$^\circ\text{C}$

## 7.6 Dissipation Ratings

PACKAGE <sup>(1)</sup>	THERMAL RESISTANCE $R_{\theta JA}$	POWER RATING $T_A \leq 25^\circ\text{C}$	DERATING FACTOR ABOVE $T_A = 25^\circ\text{C}$
YFF	84 °C/W	1190 mW	12 mW/°C

- (1) For the most current package and ordering information, see the Package Option Addendum at the end of this document, or see the TI website at [www.ti.com](http://www.ti.com).

## 7.7 Typical Characteristics

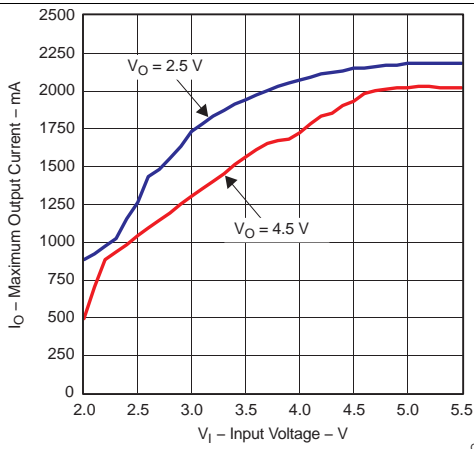

**Figure 1. Maximum Output Current vs Input Voltage (TPS63010)**

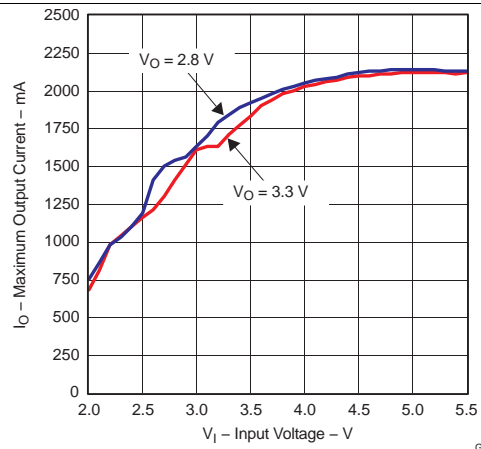

**Figure 2. Maximum Output Current vs Input Voltage (TPS63011)**

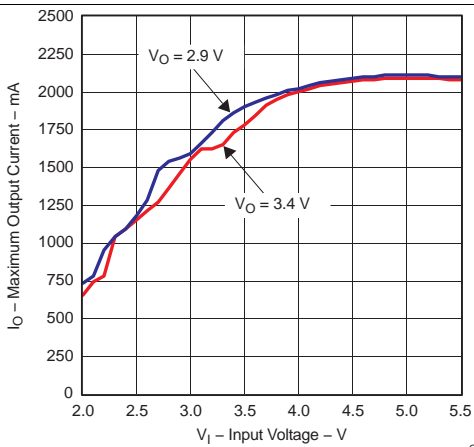

**Figure 3. Maximum Output Current vs Input Voltage (TPS63012)**

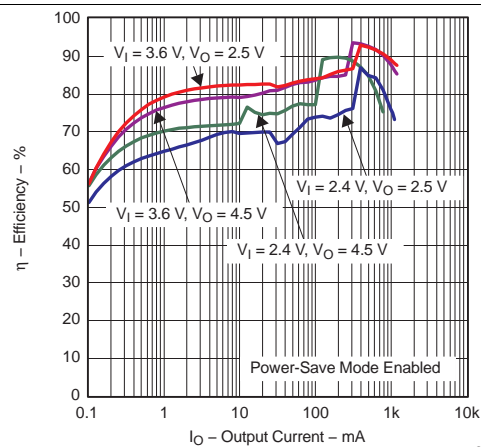

**Figure 4. Efficiency vs Output Current (TPS63010)**

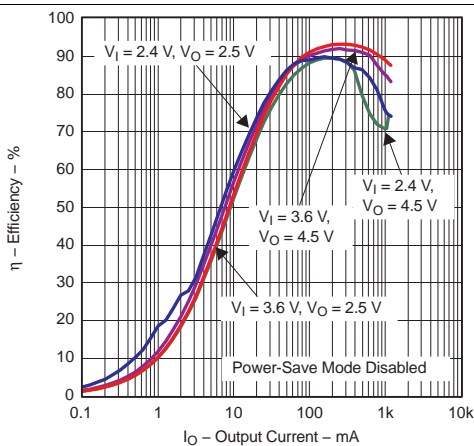

**Figure 5. Efficiency vs Output Current (TPS63010)**

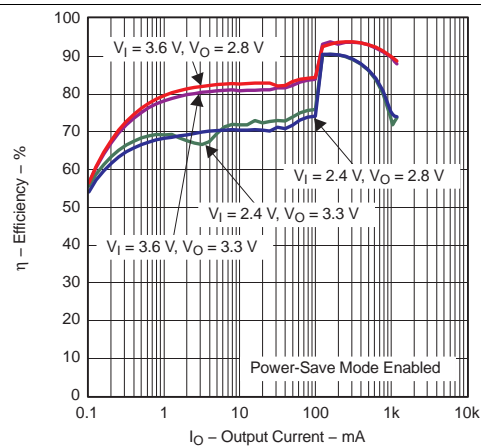

**Figure 6. Efficiency vs Output Current (TPS63011)**

Typical Characteristics (continued)

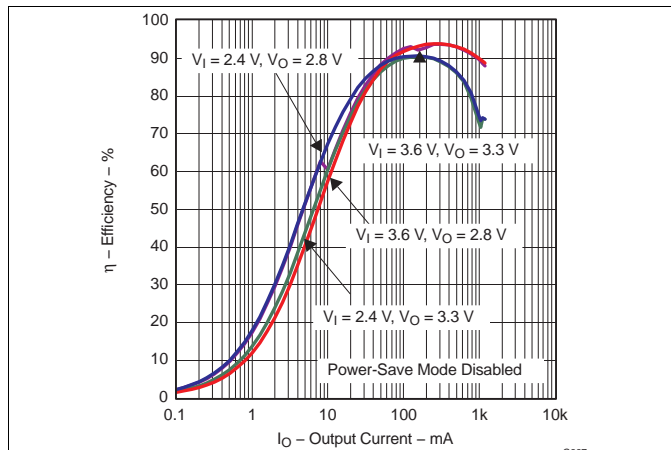

Figure 7. Efficiency vs Output Current (TPS63011)

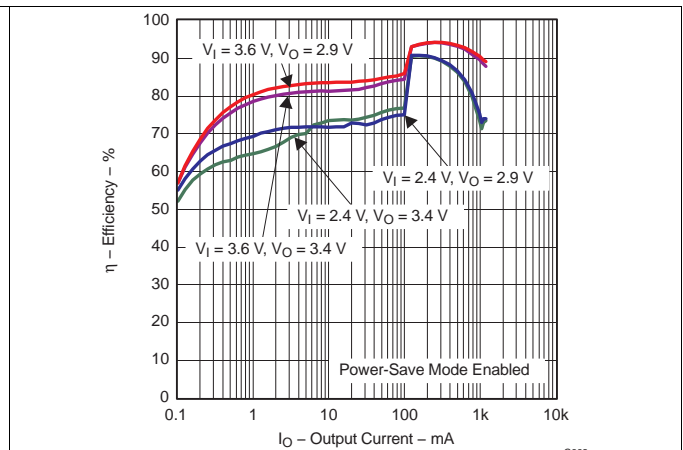

Figure 8. Efficiency vs Output Current (TPS63012)

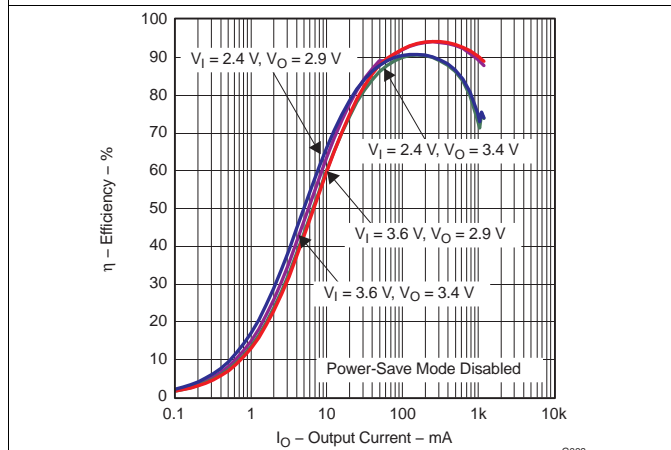

Figure 9. Efficiency vs Output Current (TPS63012)

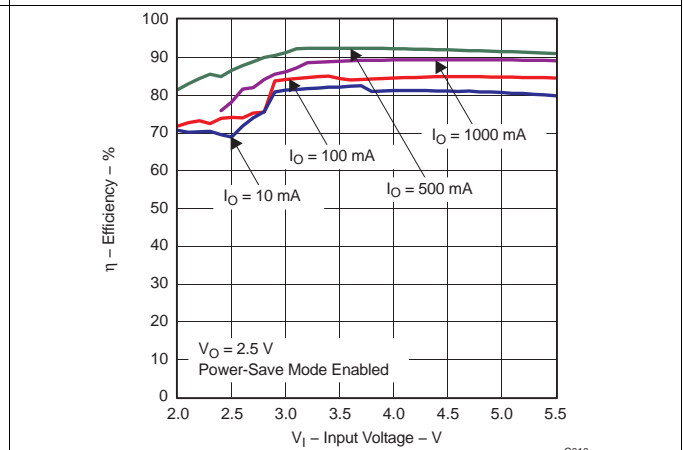

Figure 10. Efficiency vs Input Voltage (TPS63010)

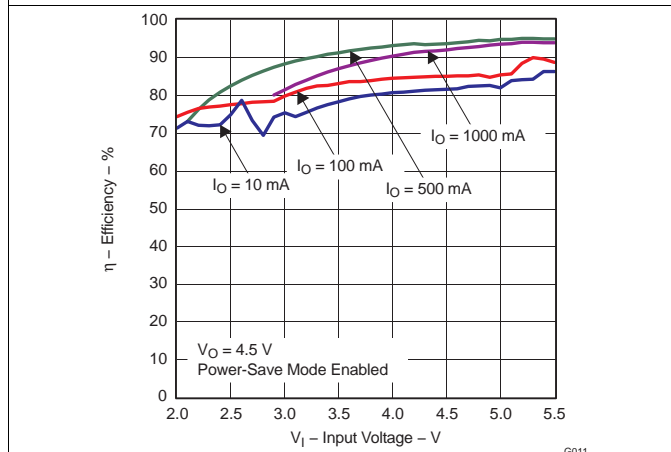

Figure 11. Efficiency vs Input Voltage (TPS63010)

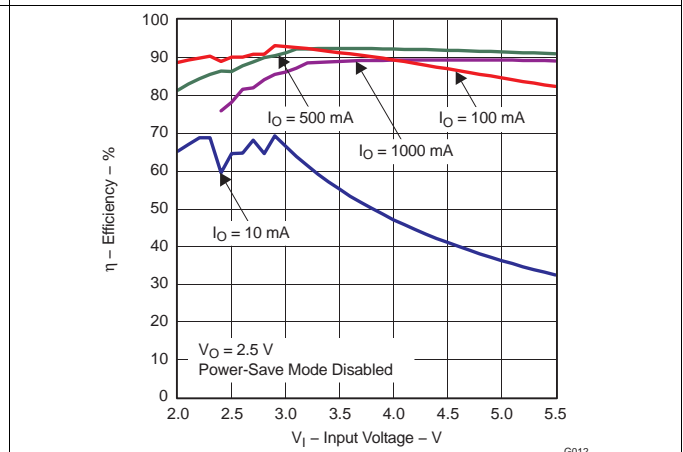

Figure 12. Efficiency vs Input Voltage (TPS63010)



Typical Characteristics (continued)

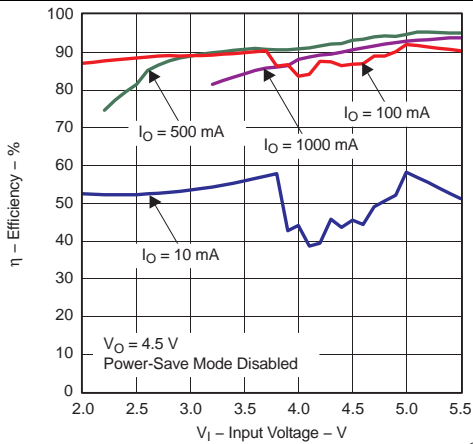

Figure 13. Efficiency vs Input Voltage (TPS63010)

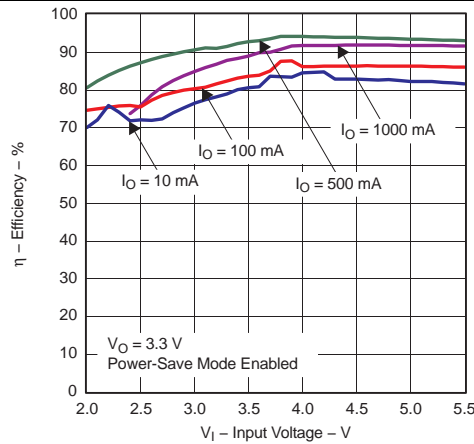

Figure 14. Efficiency vs Input Voltage (TPS63011)

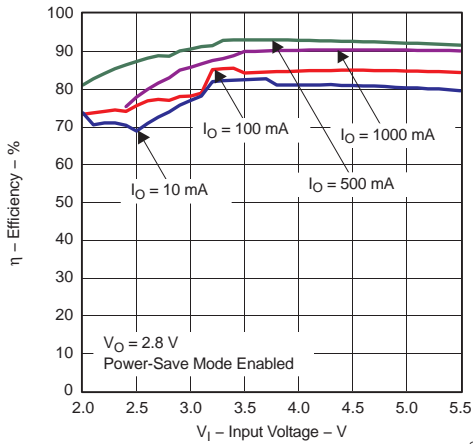

Figure 15. Efficiency vs Input Voltage (TPS63011)

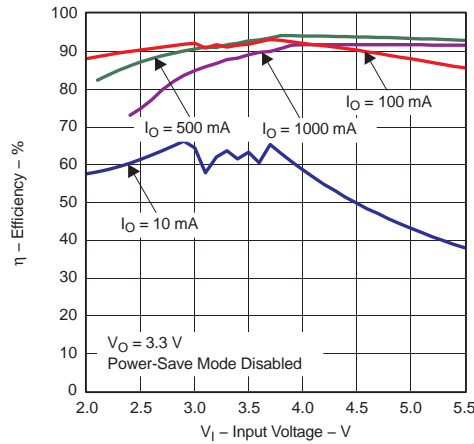

Figure 16. Efficiency vs Input Voltage (TPS63011)

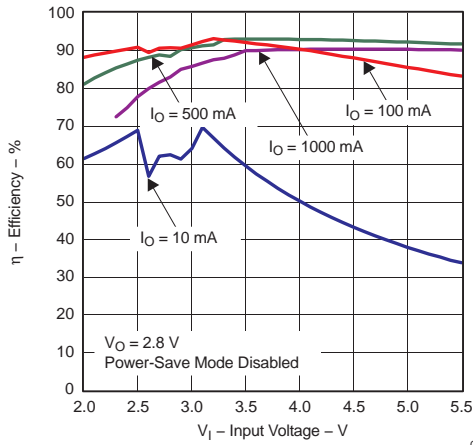

Figure 17. Efficiency vs Input Voltage (TPS63011)

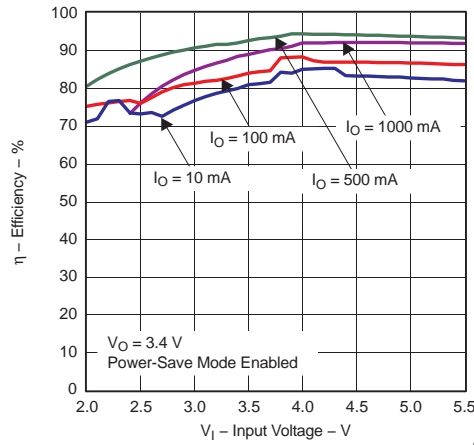

Figure 18. Efficiency vs Input Voltage (TPS63012)

Typical Characteristics (continued)

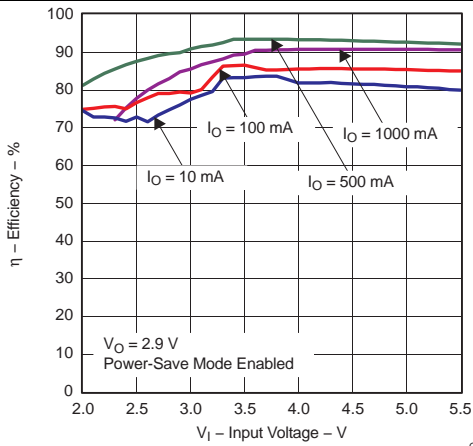

Figure 19. Efficiency vs Input Voltage (TPS63012)

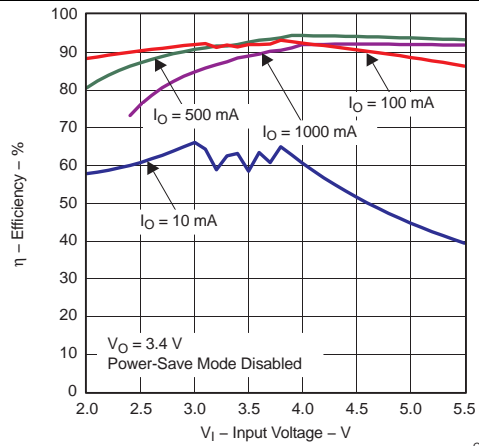

Figure 20. Efficiency vs Input Voltage (TPS63012)

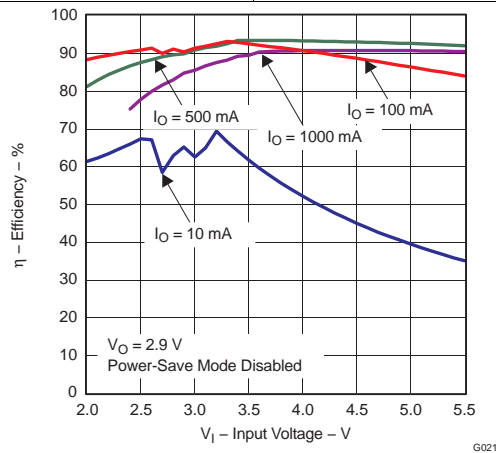

Figure 21. Efficiency vs Input Voltage (TPS63012)

## 8 Detailed Description

### 8.1 Overview

The TPS6301x uses 4 internal N-channel MOSFETs to maintain synchronous power conversion at all possible operating conditions. This enables the device to keep high efficiency over the complete input voltage and output power range. To regulate the output voltage at all possible input voltage conditions, the device automatically switches from buck operation to boost operation and back as required by the configuration. It always uses one active switch, one rectifying switch, one switch is held on, and one switch held off. Therefore, it operates as a buck converter when the input voltage is higher than the output voltage, and as a boost converter when the input voltage is lower than the output voltage. There is no mode of operation in which all 4 switches are switching at the same time. Keeping one switch on and one switch off eliminates their switching losses. The RMS current through the switches and the inductor is kept at a minimum, to minimize switching and conduction losses. Controlling the switches this way allows the converter to always keep higher efficiency. The device provides a seamless transition from buck-to-boost or from boost-to-buck operation

The device provides a seamless transition from buck-to-boost or from boost-to-buck operation.

### 8.2 Functional Block Diagrams

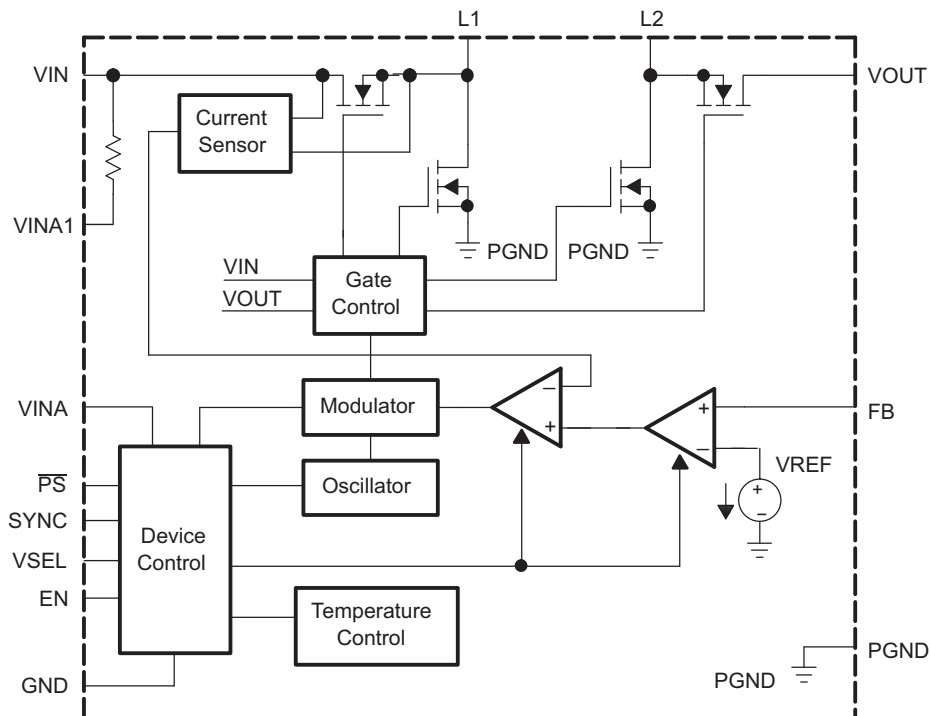
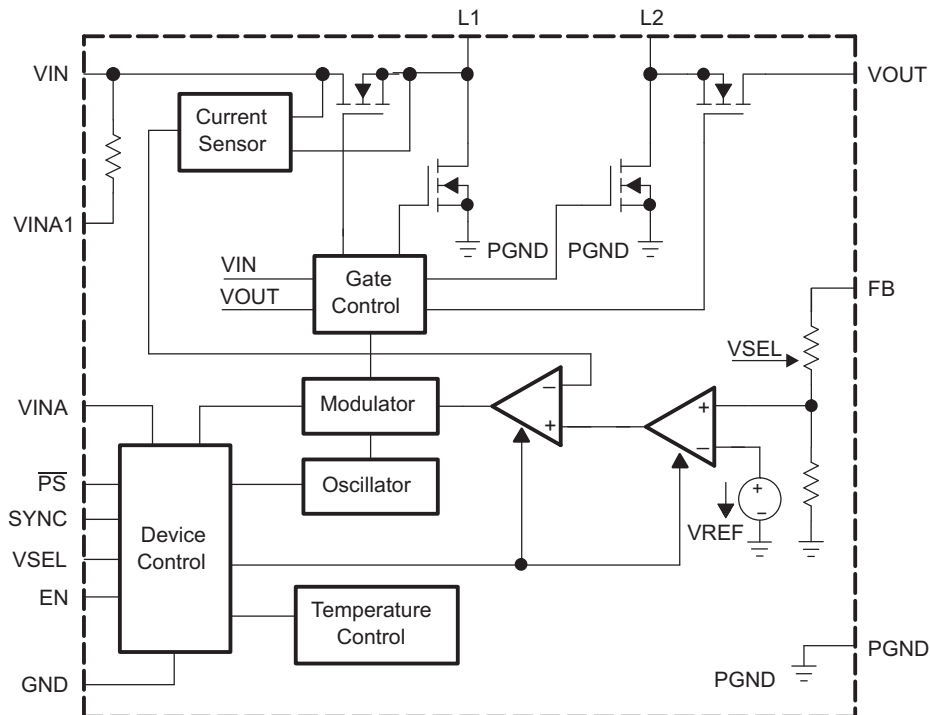

Figure 22. Functional Block Diagram (TPS63010)

**Functional Block Diagrams (continued)**

**Figure 23. Functional Block Diagram (TPS63011, TPS63012)**

## 8.3 Feature Description

### 8.3.1 Output Voltage Selection

To program the output voltage at an adjustable device option, like the TPS63010, an external resistive feedback divider connected to FB must be used. For the fixed output voltage versions, FB is used as an output voltage sense and must be connected to the output voltage  $V_{OUT}$ . All fixed output voltage versions have two different output voltages programmed internally. They are selected by programming high or low at VSEL. The higher output voltage is selected by programming VSEL high and the lower output voltage is selected by programming VSEL low. VSEL also supports standard logic thresholds.

### 8.3.2 Soft-Start and Short-Circuit Protection

After being enabled, the device starts operating. The average current limit ramps up from an initial 400 mA following the output voltage increasing. At an output voltage of about 1.2 V, the current limit is at its nominal value. If the output voltage does not increase, the current limit will not increase. There is no timer implemented. Thus, the output voltage overshoot at start-up, as well as the inrush current, is kept at a minimum. The device ramps up the output voltage in a controlled manner even if a very large capacitor is connected at the output. When the output voltage does not increase above 1.2 V, the device assumes a short-circuit at the output, and keeps the current limit low to protect itself and the application. At a short at the output during operation, the current limit is also decreased accordingly. At 0 V at the output, for example, the output current does not exceed about 400 mA.

### 8.3.3 Undervoltage Lockout

If the supply voltage on VINA is lower than its approximate threshold (see [Electrical Characteristics](#)), an undervoltage lockout function prevents device start-up. When in operation, the device automatically enters the shutdown mode if the voltage on VINA drops below the undervoltage lockout threshold. The device automatically restarts if the input voltage recovers to the minimum operating input voltage.

## Feature Description (continued)

### 8.3.4 Overvoltage Protection

If, for any reason, the output voltage is not fed back properly to the input of the voltage amplifier, control of the output voltage will not work anymore. Therefore overvoltage protection is implemented to avoid the output voltage exceeding critical values for the device and possibly for the system it is supplying. The implemented overvoltage protection circuit monitors the output voltage internally as well. In case it reaches the overvoltage threshold the voltage amplifier regulates the output voltage to this value.

### 8.3.5 Overtemperature Protection

The device has a built-in temperature sensor which monitors the internal IC temperature. If the temperature exceeds the programmed threshold (see [Electrical Characteristics](#)), the device stops operating. As soon as the IC temperature has decreased below the programmed threshold, it again starts operating. There is a built-in hysteresis to avoid unstable operation at IC temperatures at the overtemperature threshold.

## 8.4 Device Functional Modes

### 8.4.1 Controller Circuit

The controlling circuit of the device is based on an average current mode topology. The average inductor current is regulated by a fast-current regulator loop which is controlled by a voltage control loop. The controller also uses input and output voltage feedforward. Changes of input and output voltage are monitored and immediately can change the duty cycle in the modulator to achieve a fast response to those errors. The voltage error amplifier gets its feedback input from the FB pin. At adjustable output voltages a resistive voltage divider must be connected to that pin. At fixed output voltages FB must be connected to the output voltage to directly sense the voltage. Fixed output voltage versions use a trimmed internal resistive divider. The feedback voltage will be compared with the internal reference voltage to generate a stable and accurate output voltage.

The controller circuit also senses the average input current as well as the peak input current. With this, maximum input power can be controlled as well as the maximum peak current to achieve a safe and stable operation under all possible conditions. To protect the device from overheating, an internal temperature sensor is implemented.

### 8.4.2 Synchronous Operation

The device uses 4 internal N-channel MOSFETs to maintain synchronous power conversion at all possible operating conditions. This enables the device to keep high efficiency over a wide input voltage and output power range.

To avoid ground shift problems due to the high currents in the switches, two separate ground pins GND and PGND are used. The reference for all control functions is the GND pin. The power switches are connected to PGND. Both grounds must be connected on the PCB at only one point ideally close to the GND pin. Due to the 4-switch topology, the load is always disconnected from the input during shutdown of the converter.

### 8.4.3 Buck-Boost Operation

To be able to regulate the output voltage properly at all possible input voltage conditions, the device automatically switches from step-down operation to boost operation and back as required by the configuration. It always uses one active switch, one rectifying switch, one switch permanently on, and one switch permanently off. Therefore, it operates as a step-down converter (buck) when the input voltage is higher than the output voltage, and as a boost converter when the input voltage is lower than the output voltage. There is no mode of operation in which all 4 switches are permanently switching. Controlling the switches this way allows the converter to maintain high efficiency at the most important point of operation; when input voltage is close to the output voltage. The RMS current through the switches and the inductor is kept at a minimum, to minimize switching and conduction losses. Switching losses are also kept low by using only one active and one passive switch. Regarding the remaining 2 switches, one is kept permanently on and the other is kept permanently off, thus causing no switching losses.

## Device Functional Modes (continued)

### 8.4.4 Power Save Mode

The  $\overline{PS}$  pin can be used to select different operation modes. To enable power save,  $\overline{PS}$  must be set low. Power save mode is used to improve efficiency at light load. If power save mode is enabled, the converter stops operating if the average inductor current gets lower than about 300 mA and the output voltage is at or above its nominal value. If the output voltage decreases below its nominal value, the device ramps up the output voltage again by starting operation using a programmed average inductor current higher than required by the current load condition. Operation can last for one or several pulses. The converter again stops operating once the conditions for stopping operation are met again.

The power save mode can be disabled by programming high at  $\overline{PS}$ . The  $\overline{PS}$  input supports standard logic threshold voltages. If the device is synchronized to an external clock connected to SYNC, power save mode is disabled.

### 8.4.5 Synchronization

Connecting a clock signal at SYNC forces the device to synchronize to the connected clock frequency. Synchronization is done by a PLL, so synchronizing to lower and higher frequencies compared to the internal clock works without any issues. The PLL can also tolerate missing clock pulses without the converter malfunctioning. The SYNC input supports standard logic thresholds. If synchronization is not used SYNC must be tied low or connected to GND. Applying a clock signal to SYNC automatically disables the power save mode.

### 8.4.6 Device Enable

The device is put into operation when EN is set high. It is put into a shutdown mode when EN is set to GND. In shutdown mode, the regulator stops switching, all internal control circuitry is switched off, and the load is disconnected from the input. This also means that the output voltage can drop below the input voltage during shutdown. During start-up of the converter, the duty cycle and the peak current are limited in order to avoid high peak currents flowing from the input.

## 9 Application and Implementation

### NOTE

Information in the following applications sections is not part of the TI component specification, and TI does not warrant its accuracy or completeness. TI's customers are responsible for determining suitability of components for their purposes. Customers should validate and test their design implementation to confirm system functionality.

### 9.1 Application Information

The TPS6301x are high-efficiency, low-quiescent current buck-boost converters suitable for application where the input voltage is higher, lower or equal to the output. Output currents can go as high as 1 A in boost mode and as high as 2 A in buck mode. The maximum average current in the switches is limited to a typical value of 2 A.

### 9.2 Typical Application

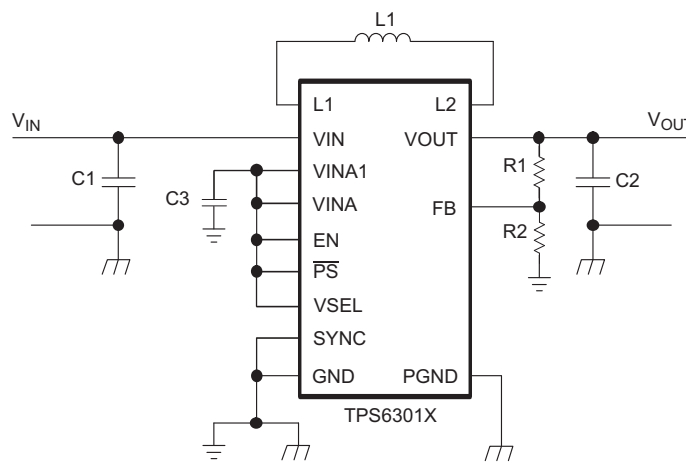

**Figure 24. Adjustable Version**

#### 9.2.1 Design Requirements

The design guideline provides a component selection to operate the device within the recommended operating conditions. [Table 2](#) lists the components for the [Application Curves](#) section.

**Table 2. Components for Application Characteristic Curves**

REFERENCE	DESCRIPTION	MANUFACTURER
	TPS6301 0 / 1 / 2	Texas Instruments
L1	LPS3015-222	Coilcraft
C1	GRM188R60J106M (10 $\mu$ F 6.3 V, 0603)	Murata
C2	2 $\times$ GRM188R60J106M (10 $\mu$ F 6.3 V, 0603)	Murata
C3	0.1 $\mu$ F, X7R ceramic	
R1, R2	Depending on the output voltage at TPS63010, not used at TPS6301 1 / 2 (R1 shorted)	

#### 9.2.2 Detailed Design Procedure

The TPS6301x DC-DC converters are intended for systems powered by one-cell Li-Ion or Li-Polymer battery with a typical voltage from 2.3 V to 4.5 V. They can also be used in systems powered by a double-cell or triple-cell Alkaline, NiCd, or NiMH battery with a typical terminal voltage from 2 V to 5.5 V. Additionally, any other voltage source with a typical output voltage from 2 V to 5.5 V can power systems where the TPS6301x is used.

### 9.2.2.1 Programming the Output Voltage

Within the TPS6301x family, there are fixed and adjustable output voltage versions available. To properly configure the fixed output voltage devices, the FB pin is used to sense the output voltage. This means that it must be connected directly to  $V_{OUT}$ . At the adjustable output voltage versions, an external resistor divider is used to adjust the output voltage. The resistor divider must be connected between  $V_{OUT}$ , FB, and GND. When the output voltage is regulated properly, the typical value of the voltage at the FB pin is 500 mV. The maximum recommended value for the output voltage is 5.5 V. The current through the resistive divider should be about 100 times greater than the current into the FB pin. The typical current into the FB pin is 0.01  $\mu\text{A}$ , and the voltage across the resistor between FB and GND,  $R_2$ , is typically 500 mV. Based on those two values, the recommended value for  $R_2$  should be lower than 500 k $\Omega$ , in order to set the divider current at 1  $\mu\text{A}$  or higher. The recommended value for this resistor is in the range of 200 k $\Omega$ . From that, the value of the resistor connected between  $V_{OUT}$  and FB,  $R_1$ , depending on the needed output voltage ( $V_{OUT}$ ), is calculated using Equation 1:

$$R_1 = R_2 \times \left( \frac{V_{OUT}}{V_{FB}} - 1 \right) \quad (1)$$

As an example, if an output voltage of 3.3 V is needed, a 1-M $\Omega$  resistor should be chosen for  $R_1$  if  $R_2$  is 180-k $\Omega$ .

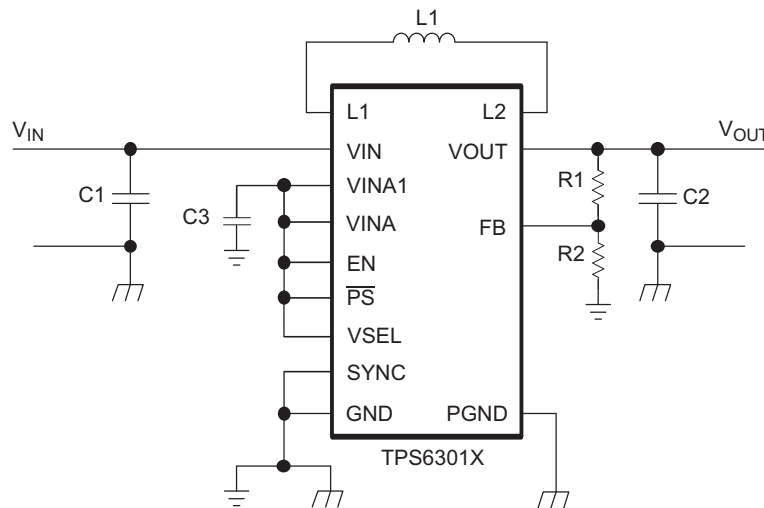

**Figure 25. Typical Application Circuit for Adjustable Output Voltage Option**

### 9.2.2.2 Inductor Selection

To properly configure the TPS6301x devices, an inductor must be connected between pin L1 and pin L2. To estimate the inductance value Equation 2 and Equation 3 can be used.

$$L_1 = (V_{IN1} - V_{OUT}) \times 0.5 \times \frac{\mu\text{S}}{\text{A}} \quad (2)$$

$$L_2 = V_{OUT} \times 0.5 \times \frac{\mu\text{S}}{\text{A}} \quad (3)$$

In Equation 2, the minimum inductance value  $L_1$  for step down mode operation is calculated.  $V_{IN1}$  is the maximum input voltage. In Equation 3 the minimum inductance,  $L_2$ , for boost mode operation is calculated. The recommended minimum inductor value is either  $L_1$  or  $L_2$  whichever is higher. As an example, a suitable inductor for generating 3.3 V from a Li-Ion battery with a battery voltage range from 2.5 V up to 4.2 V is 2.2  $\mu\text{H}$ . The recommended inductor value range is between 1  $\mu\text{H}$  and 4.7  $\mu\text{H}$ . In general, this means that at high voltage conversion rates, higher inductor values offer better performance.

With the chosen inductance value, the peak current for the inductor in steady-state operation can be calculated. Equation 4 shows how to calculate the peak current  $I_1$  in step-down mode operation and Equation 5 shows how to calculate the peak current  $I_2$  in boost mode operation.  $V_{IN2}$  is the minimum input voltage.

$$I_1 = \frac{I_{OUT}}{0.8} + \frac{V_{OUT} (V_{IN1} - V_{OUT})}{2 \times V_{IN1} \times f \times L} \quad (4)$$



$$I_2 = \frac{V_{OUT} \times I_{OUT}}{0.8 \times V_{IN2}} + \frac{V_{IN2} \times (V_{OUT} - V_{IN2})}{2 \times V_{OUT} \times f \times L} \quad (5)$$

The critical current value for selecting the right inductor is the higher value of  $I_1$  and  $I_2$ . Consider that load transients and error conditions may cause higher inductor currents, especially when selecting an appropriate inductor. The following inductor series from different suppliers have been used with TPS6301x converters:

**Table 3. List of Recommended Inductors**

VENDOR	INDUCTOR SERIES
Coilcraft	LPS3015
	LPS4012
FDK	MIPSA2520
Murata	LQH3NP
	LQM2HP
Toko	FDSE0312

### 9.2.2.3 Capacitor Selection

#### 9.2.2.3.1 Input Capacitor

At least a 4.7- $\mu$ F input capacitor is recommended to improve transient behavior of the regulator and EMI behavior of the total power supply circuit. A ceramic capacitor placed as close as possible to the VIN and PGND pins of the IC is recommended.

#### 9.2.2.3.2 Output Capacitor

For the output capacitor, TI recommends using small ceramic capacitors placed as close as possible to the VOUT and PGND pins of the IC. If, for any reason, the application requires the use of large capacitors which can not be placed close to the IC, using a smaller ceramic capacitor in parallel to the large one is recommended. This small capacitor should be placed as close as possible to the VOUT and PGND pins of the IC.

To get an estimate of the recommended minimum output capacitance, [Equation 6](#) can be used.

$$C_{OUT} = 5 \times L \times \frac{\mu F}{\mu F} \quad (6)$$

A capacitor with a value in the range of the calculated minimum should be used. This is required to maintain control loop stability. There are no additional requirements regarding minimum ESR. There is also no upper limit for the output capacitance value. Larger capacitors will cause lower output voltage ripple as well as lower output voltage drop during load transients.

### 9.2.3 Application Curves

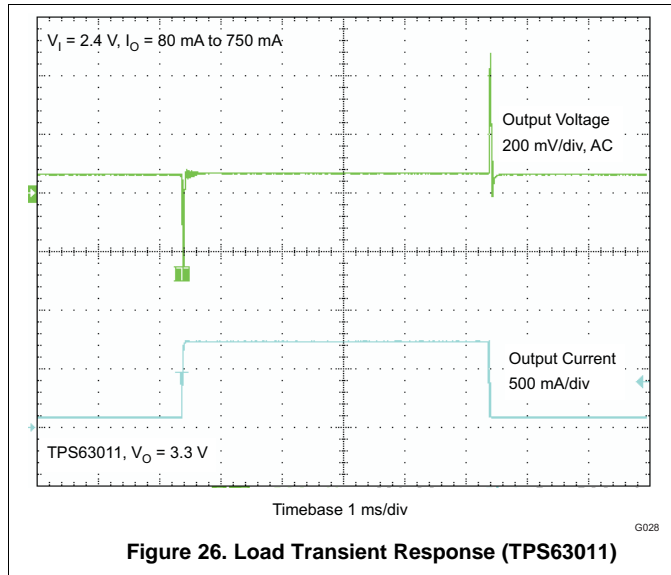

Figure 26. Load Transient Response (TPS63011)

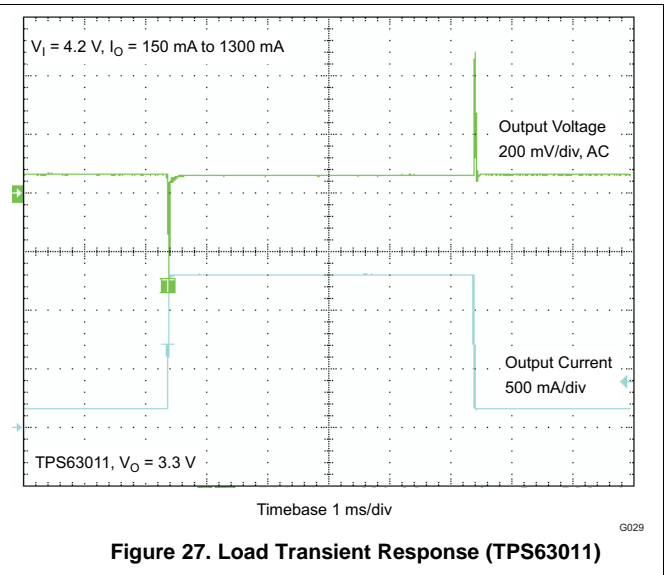

Figure 27. Load Transient Response (TPS63011)

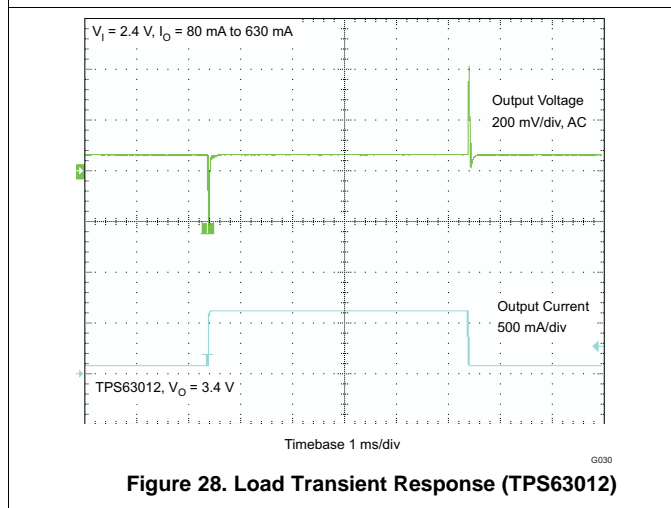

Figure 28. Load Transient Response (TPS63012)

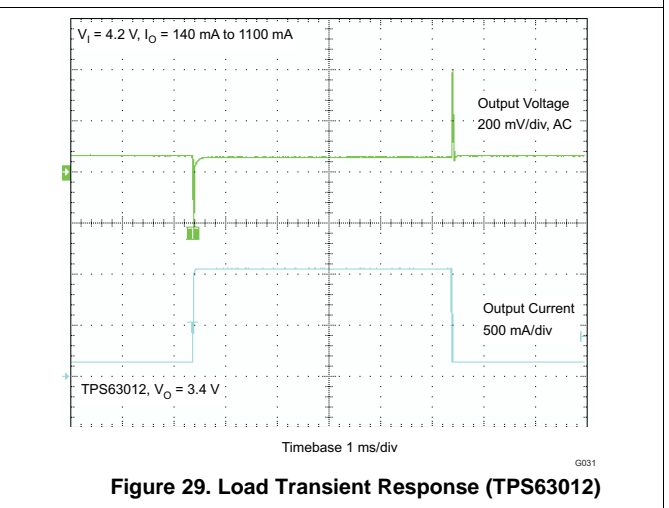

Figure 29. Load Transient Response (TPS63012)

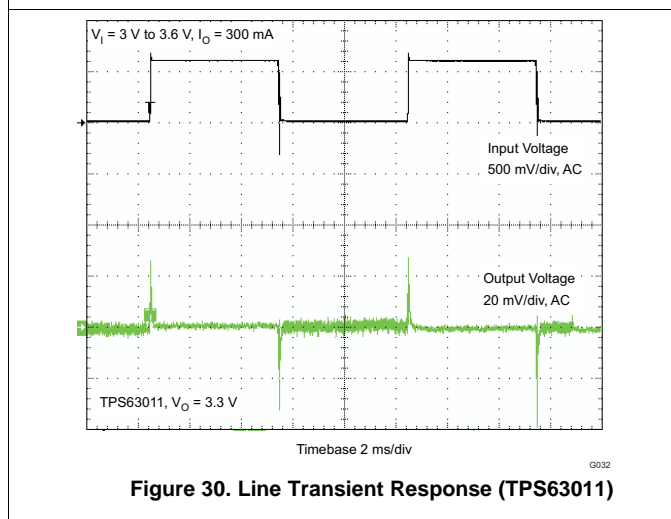

Figure 30. Line Transient Response (TPS63011)

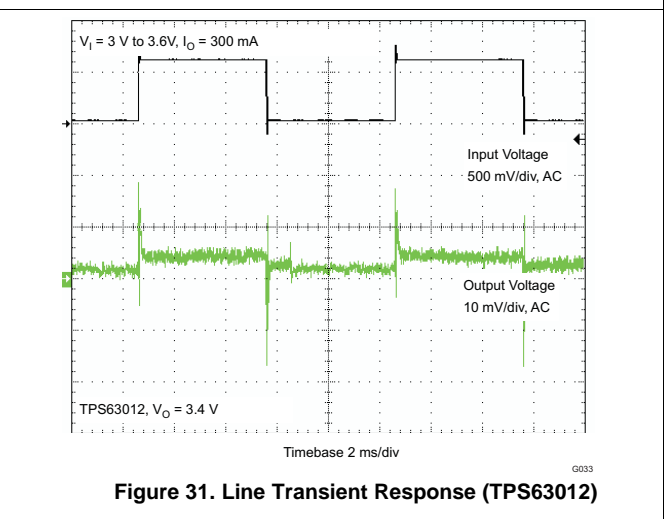
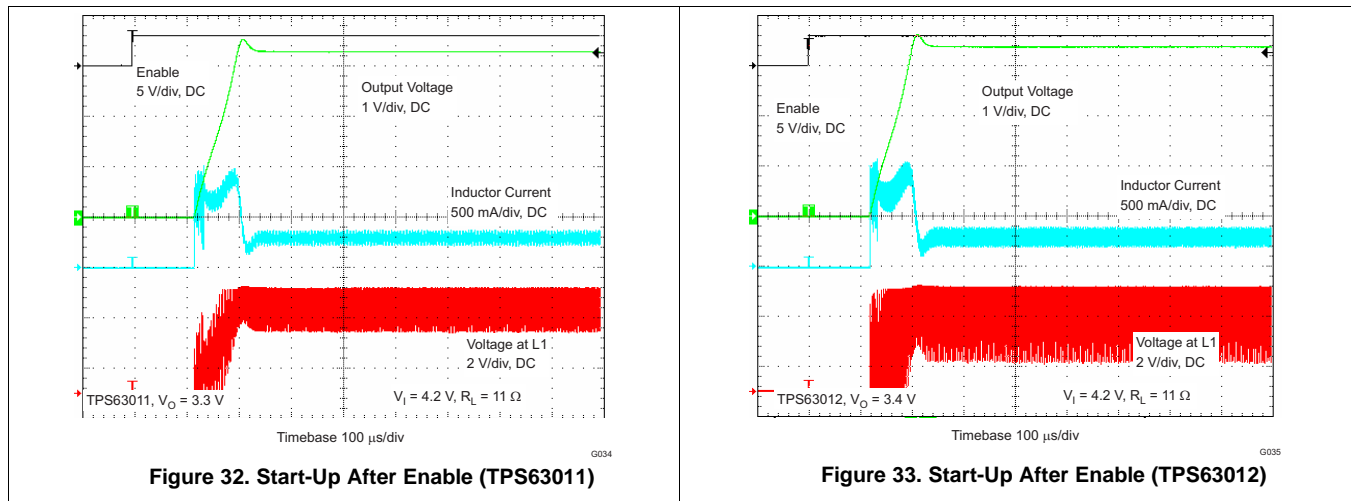

Figure 31. Line Transient Response (TPS63012)



## 10 Power Supply Recommendations

The TPS6301x device family has no special requirements for its input power supply. The output current of the input power supply must be rated according to the supply voltage, output voltage, and output current of the TPS6301x.

## 11 Layout

### 11.1 Layout Guidelines

As for all switching power supplies, the layout is an important step in the design, especially at high peak currents and high switching frequencies. If the layout is not carefully done, the regulator could show stability problems as well as EMI problems. Therefore, use wide and short traces for the main current path and for the power ground tracks. The input capacitor, output capacitor, and the inductor must be placed as close as possible to the IC. Use a common ground node for power ground and a different one for control ground to minimize the effects of ground noise. Connect these ground nodes at any place close to one of the ground pins of the IC.

The feedback divider must be placed as close as possible to the control ground pin of the IC. To lay out the control ground, TI recommends using short traces separated from the power ground traces. This avoids ground shift problems, which can occur due to superimposition of power ground current and control ground current.

### 11.2 Layout Example

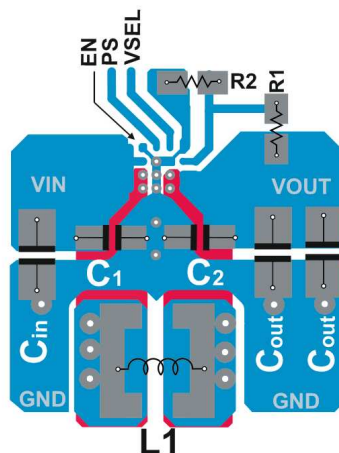

**Figure 34. PCB Layout Suggestion**

### 11.3 Thermal Consideration

Implementation of integrated circuits in low-profile and fine-pitch surface-mount packages typically requires special attention to power dissipation. Many system-dependent issues such as thermal coupling, airflow, added heat sinks and convection surfaces, and the presence of other heat-generating components affect the power-dissipation limits of a given component.

Three basic approaches for enhancing thermal performance are listed:

1. Improving the power dissipation capability of the PCB design
2. Improving the thermal coupling of the component to the PCB by soldering all pins to traces as wide as possible.
3. Introducing airflow in the system

The maximum recommended junction temperature ( $T_J$ ) of the TPS6301x devices is 125°C. The thermal resistance of this 20-pin chip-scale package (YFF) is  $R_{\theta JA} = 84^\circ\text{C/W}$ , if all pins are soldered. Specified regulator operation is assured to a maximum ambient temperature  $T_A$  of 85°C. Therefore, the maximum power dissipation is about 476 mW, as calculated in [Equation 7](#). More power can be dissipated if the maximum ambient temperature of the application is lower.

$$P_{D(\text{MAX})} = \frac{T_{J(\text{MAX})} - T_A}{R_{\theta JA}} = \frac{125^\circ\text{C} - 85^\circ\text{C}}{84^\circ\text{C/W}} = 476 \text{ mW} \quad (7)$$

## 12 Device and Documentation Support

### 12.1 Related Links

The table below lists quick access links. Categories include technical documents, support and community resources, tools and software, and quick access to sample or buy.

**Table 4. Related Links**

PARTS	PRODUCT FOLDER	SAMPLE & BUY	TECHNICAL DOCUMENTS	TOOLS & SOFTWARE	SUPPORT & COMMUNITY
TPS63010	<a href="#">Click here</a>	<a href="#">Click here</a>	<a href="#">Click here</a>	<a href="#">Click here</a>	<a href="#">Click here</a>
TPS63011	<a href="#">Click here</a>	<a href="#">Click here</a>	<a href="#">Click here</a>	<a href="#">Click here</a>	<a href="#">Click here</a>
TPS63012	<a href="#">Click here</a>	<a href="#">Click here</a>	<a href="#">Click here</a>	<a href="#">Click here</a>	<a href="#">Click here</a>

### 12.2 Community Resources

The following links connect to TI community resources. Linked contents are provided "AS IS" by the respective contributors. They do not constitute TI specifications and do not necessarily reflect TI's views; see TI's [Terms of Use](#).

**TI E2E™ Online Community** *TI's Engineer-to-Engineer (E2E) Community*. Created to foster collaboration among engineers. At [e2e.ti.com](http://e2e.ti.com), you can ask questions, share knowledge, explore ideas and help solve problems with fellow engineers.

**Design Support** *TI's Design Support* Quickly find helpful E2E forums along with design support tools and contact information for technical support.

### 12.3 Trademarks

E2E is a trademark of Texas Instruments.

All other trademarks are the property of their respective owners.

### 12.4 Electrostatic Discharge Caution



These devices have limited built-in ESD protection. The leads should be shorted together or the device placed in conductive foam during storage or handling to prevent electrostatic damage to the MOS gates.

### 12.5 Glossary

[SLYZ022](#) — *TI Glossary*.

This glossary lists and explains terms, acronyms, and definitions.

## 13 Mechanical, Packaging, and Orderable Information

The following pages include mechanical, packaging, and orderable information. This information is the most current data available for the designated devices. This data is subject to change without notice and revision of this document. For browser-based versions of this data sheet, refer to the left-hand navigation.

### 13.1 Package Dimensions

The package dimensions for this YFF package are shown in the table below. See the package drawing at the end of this data sheet for more details.

**Table 5. YFF Package Dimensions**

Packaged Devices	D	E
TPS63010YFF	2.126 ± 0.05 mm	1.922 ± 0.05 mm

**PACKAGING INFORMATION**

Orderable Device	Status (1)	Package Type	Package Drawing	Pins	Package Qty	Eco Plan (2)	Lead finish/ Ball material (6)	MSL Peak Temp (3)	Op Temp (°C)	Device Marking (4/5)	Samples
TPS63010YFFR	ACTIVE	DSBGA	YFF	20	3000	RoHS & Green	SNAGCU	Level-1-260C-UNLIM	-40 to 125	TPS63010	<a href="#">Samples</a>
TPS63010YFFT	ACTIVE	DSBGA	YFF	20	250	RoHS & Green	SNAGCU	Level-1-260C-UNLIM	-40 to 125	TPS63010	<a href="#">Samples</a>
TPS63011YFFR	ACTIVE	DSBGA	YFF	20	3000	RoHS & Green	SNAGCU	Level-1-260C-UNLIM	-40 to 125	TPS63011	<a href="#">Samples</a>
TPS63011YFFT	ACTIVE	DSBGA	YFF	20	250	RoHS & Green	SNAGCU	Level-1-260C-UNLIM	-40 to 125	TPS63011	<a href="#">Samples</a>
TPS63012YFFR	ACTIVE	DSBGA	YFF	20	3000	RoHS & Green	SNAGCU	Level-1-260C-UNLIM	-40 to 125	TPS63012	<a href="#">Samples</a>
TPS63012YFFT	ACTIVE	DSBGA	YFF	20	250	RoHS & Green	SNAGCU	Level-1-260C-UNLIM	-40 to 125	TPS63012	<a href="#">Samples</a>

(1) The marketing status values are defined as follows:

**ACTIVE:** Product device recommended for new designs.

**LIFEBUY:** TI has announced that the device will be discontinued, and a lifetime-buy period is in effect.

**NRND:** Not recommended for new designs. Device is in production to support existing customers, but TI does not recommend using this part in a new design.

**PREVIEW:** Device has been announced but is not in production. Samples may or may not be available.

**OBSOLETE:** TI has discontinued the production of the device.

(2) **RoHS:** TI defines "RoHS" to mean semiconductor products that are compliant with the current EU RoHS requirements for all 10 RoHS substances, including the requirement that RoHS substance do not exceed 0.1% by weight in homogeneous materials. Where designed to be soldered at high temperatures, "RoHS" products are suitable for use in specified lead-free processes. TI may reference these types of products as "Pb-Free".

**RoHS Exempt:** TI defines "RoHS Exempt" to mean products that contain lead but are compliant with EU RoHS pursuant to a specific EU RoHS exemption.

**Green:** TI defines "Green" to mean the content of Chlorine (Cl) and Bromine (Br) based flame retardants meet JS709B low halogen requirements of <=1000ppm threshold. Antimony trioxide based flame retardants must also meet the <=1000ppm threshold requirement.

(3) MSL, Peak Temp. - The Moisture Sensitivity Level rating according to the JEDEC industry standard classifications, and peak solder temperature.

(4) There may be additional marking, which relates to the logo, the lot trace code information, or the environmental category on the device.

(5) Multiple Device Markings will be inside parentheses. Only one Device Marking contained in parentheses and separated by a "~" will appear on a device. If a line is indented then it is a continuation of the previous line and the two combined represent the entire Device Marking for that device.

(6) Lead finish/Ball material - Orderable Devices may have multiple material finish options. Finish options are separated by a vertical ruled line. Lead finish/Ball material values may wrap to two lines if the finish value exceeds the maximum column width.

**Important Information and Disclaimer:** The information provided on this page represents TI's knowledge and belief as of the date that it is provided. TI bases its knowledge and belief on information provided by third parties, and makes no representation or warranty as to the accuracy of such information. Efforts are underway to better integrate information from third parties. TI has taken and continues to take reasonable steps to provide representative and accurate information but may not have conducted destructive testing or chemical analysis on incoming materials and chemicals. TI and TI suppliers consider certain information to be proprietary, and thus CAS numbers and other limited information may not be available for release.

In no event shall TI's liability arising out of such information exceed the total purchase price of the TI part(s) at issue in this document sold by TI to Customer on an annual basis.

**TAPE AND REEL INFORMATION**

**QUADRANT ASSIGNMENTS FOR PIN 1 ORIENTATION IN TAPE**

\*All dimensions are nominal

Device	Package Type	Package Drawing	Pins	SPQ	Reel Diameter (mm)	Reel Width W1 (mm)	A0 (mm)	B0 (mm)	K0 (mm)	P1 (mm)	W (mm)	Pin1 Quadrant
TPS63010YFFR	DSBGA	YFF	20	3000	180.0	8.4	2.2	2.35	0.8	4.0	8.0	Q1
TPS63010YFFT	DSBGA	YFF	20	250	180.0	8.4	2.2	2.35	0.8	4.0	8.0	Q1
TPS63011YFFR	DSBGA	YFF	20	3000	180.0	8.4	2.2	2.35	0.8	4.0	8.0	Q1
TPS63011YFFT	DSBGA	YFF	20	250	180.0	8.4	2.2	2.35	0.8	4.0	8.0	Q1
TPS63012YFFR	DSBGA	YFF	20	3000	180.0	8.4	2.2	2.35	0.8	4.0	8.0	Q1
TPS63012YFFT	DSBGA	YFF	20	250	180.0	8.4	2.2	2.35	0.8	4.0	8.0	Q1

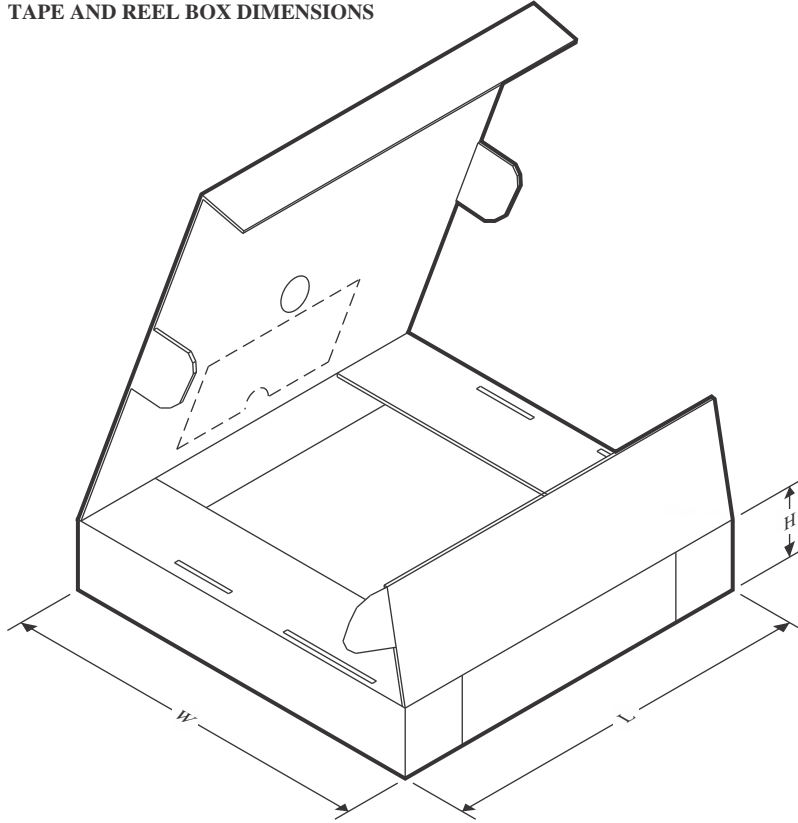

**TAPE AND REEL BOX DIMENSIONS**

\*All dimensions are nominal

Device	Package Type	Package Drawing	Pins	SPQ	Length (mm)	Width (mm)	Height (mm)
TPS63010YFFR	DSBGA	YFF	20	3000	182.0	182.0	20.0
TPS63010YFFT	DSBGA	YFF	20	250	182.0	182.0	20.0
TPS63011YFFR	DSBGA	YFF	20	3000	182.0	182.0	20.0
TPS63011YFFT	DSBGA	YFF	20	250	182.0	182.0	20.0
TPS63012YFFR	DSBGA	YFF	20	3000	182.0	182.0	20.0
TPS63012YFFT	DSBGA	YFF	20	250	182.0	182.0	20.0

# MECHANICAL DATA

YFF (R-XBGA-N20)

DIE-SIZE BALL GRID ARRAY

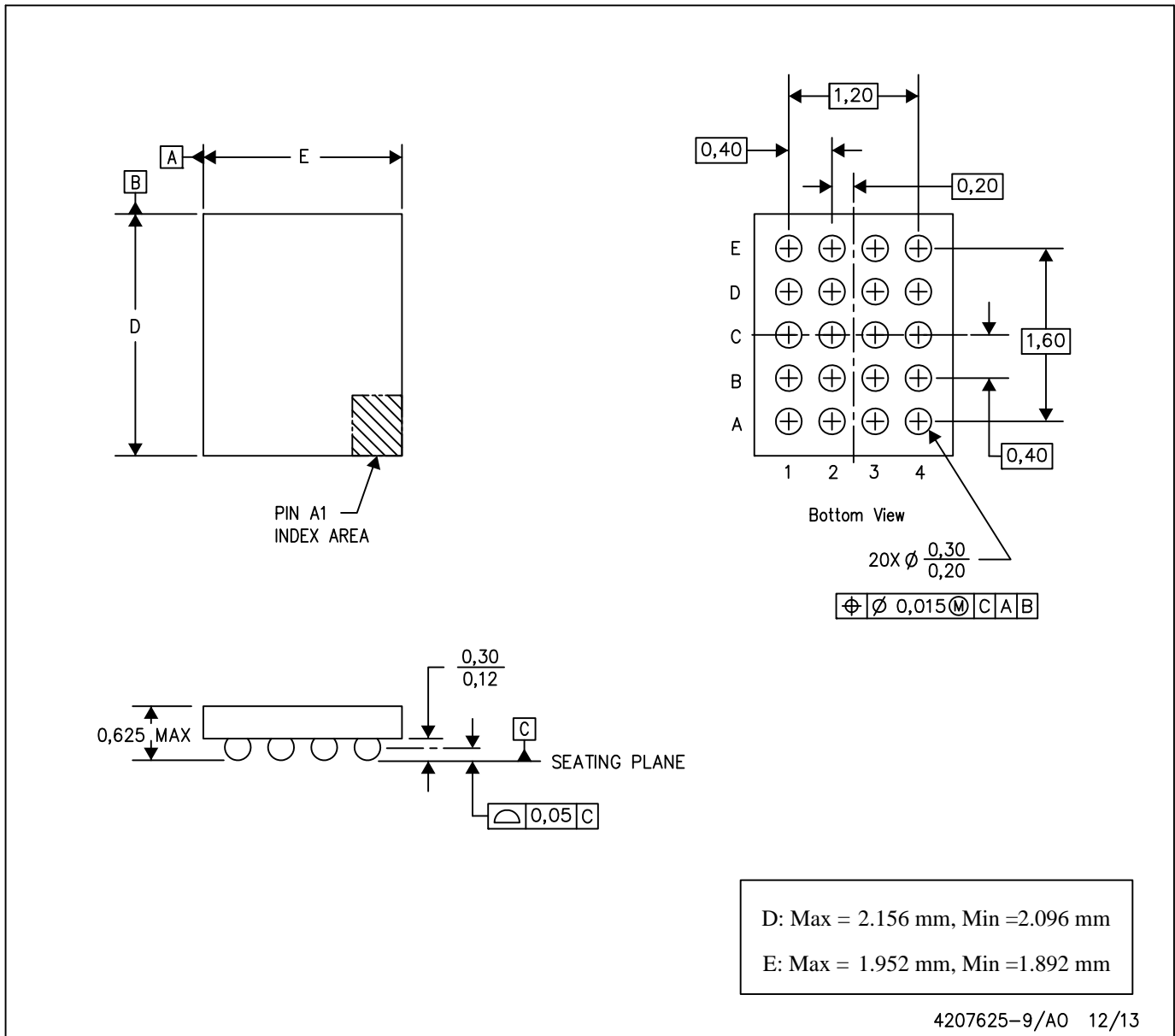

- NOTES: A. All linear dimensions are in millimeters. Dimensioning and tolerancing per ASME Y14.5M-1994.  
 B. This drawing is subject to change without notice.  
 C. NanoFree™ package configuration.

NanoFree is a trademark of Texas Instruments.

## IMPORTANT NOTICE AND DISCLAIMER

TI PROVIDES TECHNICAL AND RELIABILITY DATA (INCLUDING DATA SHEETS), DESIGN RESOURCES (INCLUDING REFERENCE DESIGNS), APPLICATION OR OTHER DESIGN ADVICE, WEB TOOLS, SAFETY INFORMATION, AND OTHER RESOURCES "AS IS" AND WITH ALL FAULTS, AND DISCLAIMS ALL WARRANTIES, EXPRESS AND IMPLIED, INCLUDING WITHOUT LIMITATION ANY IMPLIED WARRANTIES OF MERCHANTABILITY, FITNESS FOR A PARTICULAR PURPOSE OR NON-INFRINGEMENT OF THIRD PARTY INTELLECTUAL PROPERTY RIGHTS.

These resources are intended for skilled developers designing with TI products. You are solely responsible for (1) selecting the appropriate TI products for your application, (2) designing, validating and testing your application, and (3) ensuring your application meets applicable standards, and any other safety, security, regulatory or other requirements.

These resources are subject to change without notice. TI grants you permission to use these resources only for development of an application that uses the TI products described in the resource. Other reproduction and display of these resources is prohibited. No license is granted to any other TI intellectual property right or to any third party intellectual property right. TI disclaims responsibility for, and you will fully indemnify TI and its representatives against, any claims, damages, costs, losses, and liabilities arising out of your use of these resources.

TI's products are provided subject to [TI's Terms of Sale](#) or other applicable terms available either on [ti.com](https://www.ti.com) or provided in conjunction with such TI products. TI's provision of these resources does not expand or otherwise alter TI's applicable warranties or warranty disclaimers for TI products.

TI objects to and rejects any additional or different terms you may have proposed.

Mailing Address: Texas Instruments, Post Office Box 655303, Dallas, Texas 75265  
Copyright © 2024, Texas Instruments Incorporated