

TPS650332-Q1 汽车摄像头 PMIC

1 特性

- 符合汽车应用要求
- 系统功能符合 ASIL D 和 SIL 3 要求
- 硬件完整性高达 ASIL B 和 SIL 2 级
- 高级诊断和保护
- 符合 AEC-Q100 1 级标准
 - 40°C 至 125°C 环境温度工作温度范围
- 三个降压转换器：
 - BUCK1 V_{IN} 范围为 4.0V 至 18.3V
 - BUCK1 V_{OUT} 范围为 2.5V 至 4.0V
 - BUCK1 输出电流高达 1500mA
 - BUCK2 和 BUCK3 V_{IN} 范围为 2.5 V 至 5.5V
 - BUCK2 和 BUCK3 V_{OUT} 范围为 0.9V 至 1.9V
 - BUCK2 and BUCK3 输出电流高达 1200mA
 - 用于降低 EMI 的扩频时钟 (SSC) 发生器
 - 2.3MHz 强制固定开关频率 PWM 模式工作
- 一个低压降 (LDO) 稳压器：
 - V_{IN} 范围为 2.5 V 至 5.5V
 - V_{OUT} 范围为 1.8V 至 3.3V
 - 低噪声和高 PSRR
 - 可通过 I²C 调节的输出电压
 - 高达 300mA 的输出电流
- 具有可湿性侧面的 4.0mm × 4.0mm 24 引脚 VQFN 封装

2 应用

- 汽车摄像头模块
 - 环视摄像头模块
 - 后视摄像头模块
 - 驾驶员监控摄像头模块
 - 同轴电缆供电 (POC) 摄像头模块
 - 电子视镜摄像头模块
 - 前视摄像头模块

3 说明

TPS650332-Q1 器件是一种高度集成的电源管理 IC，可适用于汽车摄像头模块。此器件包含三个降压转换器和一个低压降 (LDO) 稳压器。BUCK1 降压转换器的输入电压范围高达 18.3V，用于连接到同轴电缆 (PoC)。所有转换器都在强制固定频率 PWM 模式下工作。LDO 可提供 300mA 电流，并可在 2.5V 至 5.5V 的输入电压范围内正常运行。降压转换器和 LDO 具有独立的电压输入，可实现最大的设计和排序灵活性。

TPS650332-Q1 采用 24 引脚 VQFN 封装 (4.00mm × 4.00mm)。

器件信息

| 器件型号 ⁽¹⁾ | 封装 | 封装尺寸 (标称值) |
|---------------------|-----------|-----------------|
| TPS650332-Q1 | VQFN (24) | 4.00mm × 4.00mm |

(1) 如需了解所有可用封装，请参阅数据表末尾的可订购产品附录。

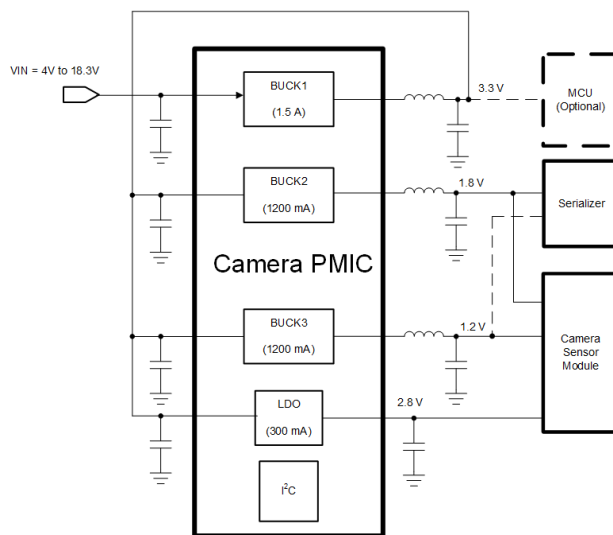

TPS650332-Q1 应用电路



Table of Contents

| | | | |
|---|---|--|---|
| 1 特性..... | 1 | 5.2 接收文档更新通知..... | 3 |
| 2 应用..... | 1 | 5.3 支持资源..... | 3 |
| 3 说明..... | 1 | 5.4 Trademarks..... | 3 |
| 4 Revision History..... | 2 | 5.5 静电放电警告..... | 3 |
| 5 Device and Documentation Support..... | 3 | 5.6 术语表..... | 3 |
| 5.1 Device Support..... | 3 | 6 Mechanical, Packaging, and Orderable Information.... | 3 |

4 Revision History

注：以前版本的页码可能与当前版本的页码不同

| DATE | REVISION | NOTES |
|----------------|----------|-----------------|
| September 2023 | * | Initial Release |

5 Device and Documentation Support

5.1 Device Support

5.1.1 第三方产品免责声明

TI 发布的与第三方产品或服务有关的信息，不能构成与此类产品或服务或保修的适用性有关的认可，不能构成此类产品或服务单独或与任何 TI 产品或服务一起的表示或认可。

5.2 接收文档更新通知

要接收文档更新通知，请导航至 ti.com 上的器件产品文件夹。点击 [订阅更新](#) 进行注册，即可每周接收产品信息更改摘要。有关更改的详细信息，请查看任何已修订文档中包含的修订历史记录。

5.3 支持资源

TI E2E™ [支持论坛](#) 是工程师的重要参考资料，可直接从专家获得快速、经过验证的解答和设计帮助。搜索现有解答或提出自己的问题可获得所需的快速设计帮助。

链接的内容由各个贡献者“按原样”提供。这些内容并不构成 TI 技术规范，并且不一定反映 TI 的观点；请参阅 TI 的 [《使用条款》](#)。

5.4 Trademarks

TI E2E™ is a trademark of Texas Instruments.

所有商标均为其各自所有者的财产。

5.5 静电放电警告



静电放电 (ESD) 会损坏这个集成电路。德州仪器 (TI) 建议通过适当的预防措施处理所有集成电路。如果不遵守正确的处理和安装程序，可能会损坏集成电路。

ESD 的损坏小至导致微小的性能降级，大至整个器件故障。精密的集成电路可能更容易受到损坏，这是因为非常细微的参数更改都可能会导致器件与其发布的规格不相符。

5.6 术语表

[TI 术语表](#) 本术语表列出并解释了术语、首字母缩略词和定义。

6 Mechanical, Packaging, and Orderable Information

The following pages include mechanical, packaging, and orderable information. This information is the most current data available for the designated devices. This data is subject to change without notice and revision of this document. For browser-based versions of this data sheet, refer to the left-hand navigation.

PACKAGING INFORMATION

| Orderable Device | Status (1) | Package Type | Package Drawing | Pins | Package Qty | Eco Plan (2) | Lead finish/ Ball material (6) | MSL Peak Temp (3) | Op Temp (°C) | Device Marking (4/5) | Samples |
|--------------------|---------------|--------------|-----------------|------|-------------|-----------------|--------------------------------------|----------------------|--------------|-------------------------|-------------------------|
| TPS65033200RGERQ1 | ACTIVE | VQFN | RGE | 24 | 3000 | RoHS & Green | NIPDAU SN | Level-3-260C-168 HR | -40 to 125 | TPS6503 XXXX-Q1 | Samples |
| TPS65033201RGERQ1 | ACTIVE | VQFN | RGE | 24 | 3000 | RoHS & Green | NIPDAU SN | Level-3-260C-168 HR | -40 to 125 | TPS6503 3201-Q1 | Samples |
| TPS65033203RGERQ1 | ACTIVE | VQFN | RGE | 24 | 3000 | RoHS & Green | NIPDAU SN | Level-3-260C-168 HR | -40 to 125 | TPS6503 3203-Q1 | Samples |
| TPS65033205QRGERQ1 | ACTIVE | VQFN | RGE | 24 | 3000 | RoHS & Green | NIPDAU SN | Level-3-260C-168 HR | -40 to 125 | TPS6503 3205-Q1 | Samples |
| TPS65033206RGERQ1 | ACTIVE | VQFN | RGE | 24 | 3000 | RoHS & Green | NIPDAU SN | Level-3-260C-168 HR | -40 to 125 | TPS6503 3206-Q1 | Samples |
| TPS65033207RGERQ1 | ACTIVE | VQFN | RGE | 24 | 3000 | RoHS & Green | NIPDAU SN | Level-3-260C-168 HR | -40 to 125 | TPS6503 3207-Q1 | Samples |
| TPS65033208RGERQ1 | ACTIVE | VQFN | RGE | 24 | 3000 | RoHS & Green | NIPDAU SN | Level-3-260C-168 HR | -40 to 125 | TPS6503 3208-Q1 | Samples |
| TPS65033209QRGERQ1 | ACTIVE | VQFN | RGE | 24 | 3000 | RoHS & Green | NIPDAU SN | Level-3-260C-168 HR | -40 to 125 | TPS6503 3209-Q1 | Samples |
| TPS6503320AARGERQ1 | ACTIVE | VQFN | RGE | 24 | 3000 | RoHS & Green | NIPDAU SN | Level-3-260C-168 HR | -40 to 125 | TPS6503 320AAQ1 | Samples |
| TPS6503320CRGERQ1 | ACTIVE | VQFN | RGE | 24 | 3000 | RoHS & Green | SN | Level-3-260C-168 HR | -40 to 125 | TPS6503 320C-Q1 | Samples |
| TPS6503320DRGERQ1 | ACTIVE | VQFN | RGE | 24 | 3000 | RoHS & Green | NIPDAU SN | Level-3-260C-168 HR | -40 to 125 | TPS6503 320D-Q1 | Samples |
| TPS6503320FRGERQ1 | ACTIVE | VQFN | RGE | 24 | 3000 | RoHS & Green | NIPDAU SN | Level-3-260C-168 HR | -40 to 125 | TPS6503 320F-Q1 | Samples |
| TPS6503320GRGERQ1 | ACTIVE | VQFN | RGE | 24 | 3000 | RoHS & Green | NIPDAU SN | Level-3-260C-168 HR | -40 to 125 | TPS6503 320G-Q1 | Samples |
| TPS6503320HARGERQ1 | ACTIVE | VQFN | RGE | 24 | 3000 | RoHS & Green | NIPDAU SN | Level-3-260C-168 HR | -40 to 125 | TPS6503 320HAQ1 | Samples |
| TPS6503320KRGERQ1 | ACTIVE | VQFN | RGE | 24 | 3000 | RoHS & Green | NIPDAU SN | Level-3-260C-168 HR | -40 to 125 | TPS6503 320K-Q1 | Samples |
| TPS6503320MRGERQ1 | ACTIVE | VQFN | RGE | 24 | 3000 | RoHS & Green | NIPDAU SN | Level-3-260C-168 HR | -40 to 125 | TPS6503 320M-Q1 | Samples |
| TPS6503320NRGERQ1 | ACTIVE | VQFN | RGE | 24 | 3000 | RoHS & Green | NIPDAU SN | Level-3-260C-168 HR | -40 to 125 | TPS6503 | Samples |

| Orderable Device | Status (1) | Package Type | Package Drawing | Pins | Package Qty | Eco Plan (2) | Lead finish/ Ball material (6) | MSL Peak Temp (3) | Op Temp (°C) | Device Marking (4/5) | Samples |
|--------------------|---------------|--------------|-----------------|------|-------------|-----------------|--------------------------------------|----------------------|--------------|-------------------------|-------------------------|
| | | | | | | | | | | 320N-Q1 | |
| TPS6503320PRGERQ1 | ACTIVE | VQFN | RGE | 24 | 3000 | RoHS & Green | NIPDAU SN | Level-3-260C-168 HR | -40 to 125 | TPS6503 320P-Q1 | Samples |
| TPS6503321MCRGERQ1 | ACTIVE | VQFN | RGE | 24 | 3000 | RoHS & Green | NIPDAU | Level-3-260C-168 HR | -40 to 125 | TPS6503 321MCQ1 | Samples |

(1) The marketing status values are defined as follows:

ACTIVE: Product device recommended for new designs.

LIFEBUY: TI has announced that the device will be discontinued, and a lifetime-buy period is in effect.

NRND: Not recommended for new designs. Device is in production to support existing customers, but TI does not recommend using this part in a new design.

PREVIEW: Device has been announced but is not in production. Samples may or may not be available.

OBsolete: TI has discontinued the production of the device.

(2) **RoHS:** TI defines "RoHS" to mean semiconductor products that are compliant with the current EU RoHS requirements for all 10 RoHS substances, including the requirement that RoHS substance do not exceed 0.1% by weight in homogeneous materials. Where designed to be soldered at high temperatures, "RoHS" products are suitable for use in specified lead-free processes. TI may reference these types of products as "Pb-Free".

RoHS Exempt: TI defines "RoHS Exempt" to mean products that contain lead but are compliant with EU RoHS pursuant to a specific EU RoHS exemption.

Green: TI defines "Green" to mean the content of Chlorine (Cl) and Bromine (Br) based flame retardants meet JS709B low halogen requirements of <=100ppm threshold. Antimony trioxide based flame retardants must also meet the <=1000ppm threshold requirement.

(3) MSL, Peak Temp. - The Moisture Sensitivity Level rating according to the JEDEC industry standard classifications, and peak solder temperature.

(4) There may be additional marking, which relates to the logo, the lot trace code information, or the environmental category on the device.

(5) Multiple Device Markings will be inside parentheses. Only one Device Marking contained in parentheses and separated by a "~" will appear on a device. If a line is indented then it is a continuation of the previous line and the two combined represent the entire Device Marking for that device.

(6) Lead finish/Ball material - Orderable Devices may have multiple material finish options. Finish options are separated by a vertical ruled line. Lead finish/Ball material values may wrap to two lines if the finish value exceeds the maximum column width.

Important Information and Disclaimer:The information provided on this page represents TI's knowledge and belief as of the date that it is provided. TI bases its knowledge and belief on information provided by third parties, and makes no representation or warranty as to the accuracy of such information. Efforts are underway to better integrate information from third parties. TI has taken and continues to take reasonable steps to provide representative and accurate information but may not have conducted destructive testing or chemical analysis on incoming materials and chemicals. TI and TI suppliers consider certain information to be proprietary, and thus CAS numbers and other limited information may not be available for release.

In no event shall TI's liability arising out of such information exceed the total purchase price of the TI part(s) at issue in this document sold by TI to Customer on an annual basis.

RGE 24

GENERIC PACKAGE VIEW

VQFN - 1 mm max height

PLASTIC QUAD FLATPACK - NO LEAD



Images above are just a representation of the package family, actual package may vary.
Refer to the product data sheet for package details.

4204104/H

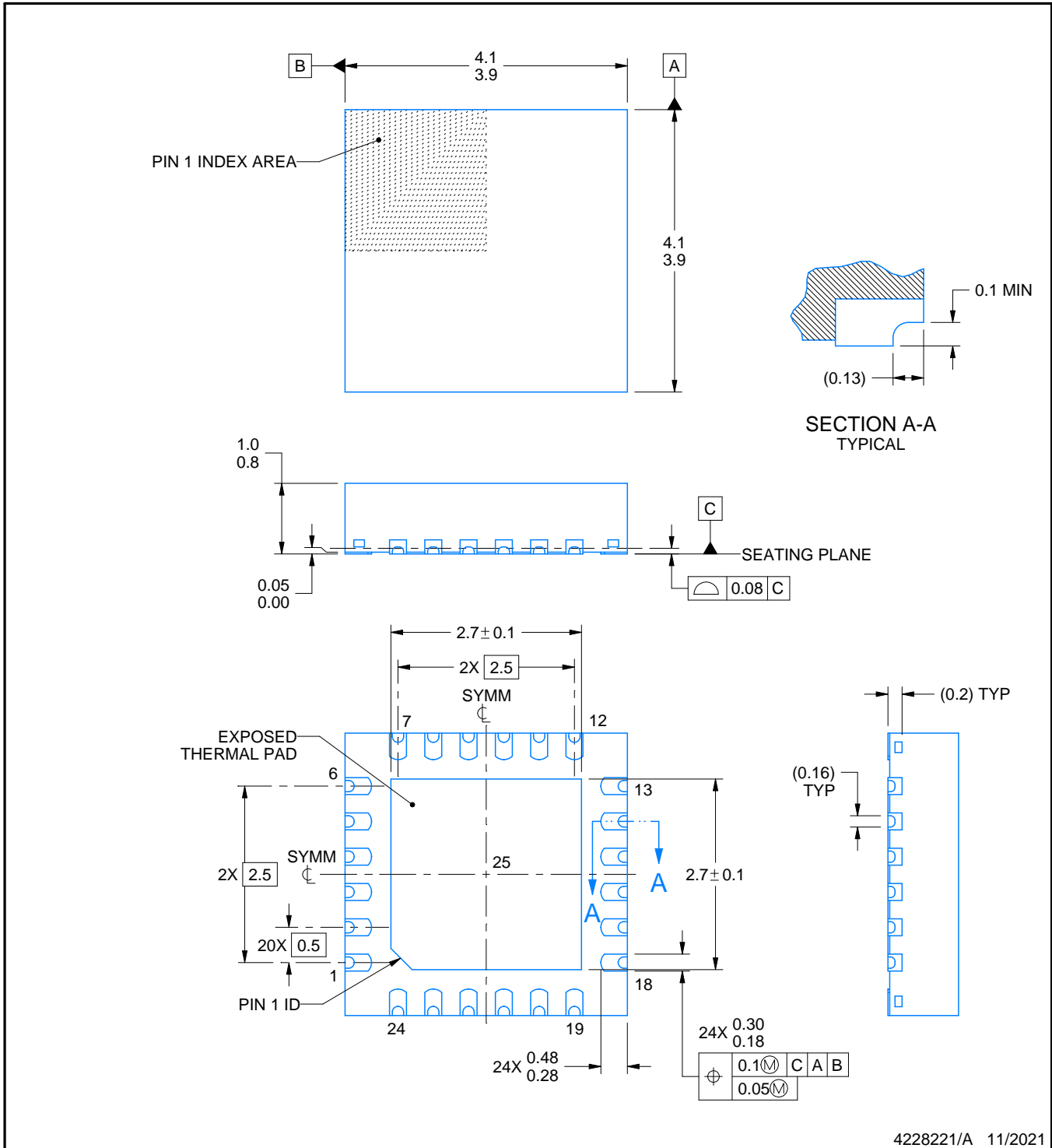
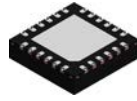

4228221/A 11/2021

NOTES:

1. All linear dimensions are in millimeters. Any dimensions in parenthesis are for reference only. Dimensioning and tolerancing per ASME Y14.5M.
2. This drawing is subject to change without notice.
3. The package thermal pad must be soldered to the printed circuit board for thermal and mechanical performance.

EXAMPLE BOARD LAYOUT

RGE0024U

VQFN - 1 mm max height

PLASTIC QUAD FLATPACK - NO LEAD

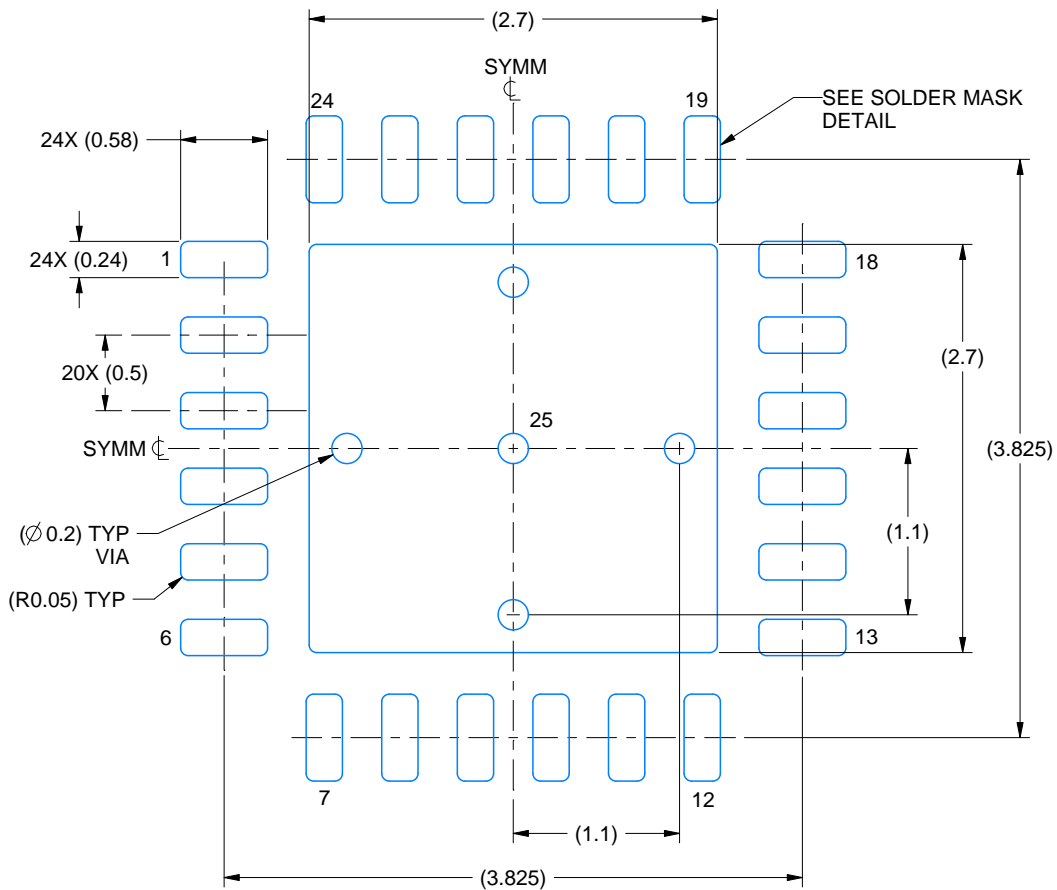

LAND PATTERN EXAMPLE
EXPOSED METAL SHOWN
SCALE: 20X

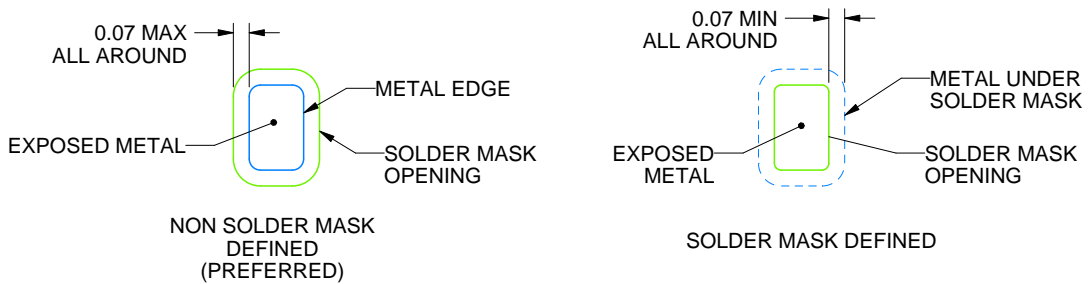

SOLDER MASK DETAILS

4228221/A 11/2021

NOTES: (continued)

4. This package is designed to be soldered to a thermal pad on the board. For more information, see Texas Instruments literature number SLUA271 (www.ti.com/lit/slua271).
5. Vias are optional depending on application, refer to device data sheet. If any vias are implemented, refer to their locations shown on this view. It is recommended that vias under paste be filled, plugged or tented.

EXAMPLE STENCIL DESIGN

RGE0024U

VQFN - 1 mm max height

PLASTIC QUAD FLATPACK - NO LEAD

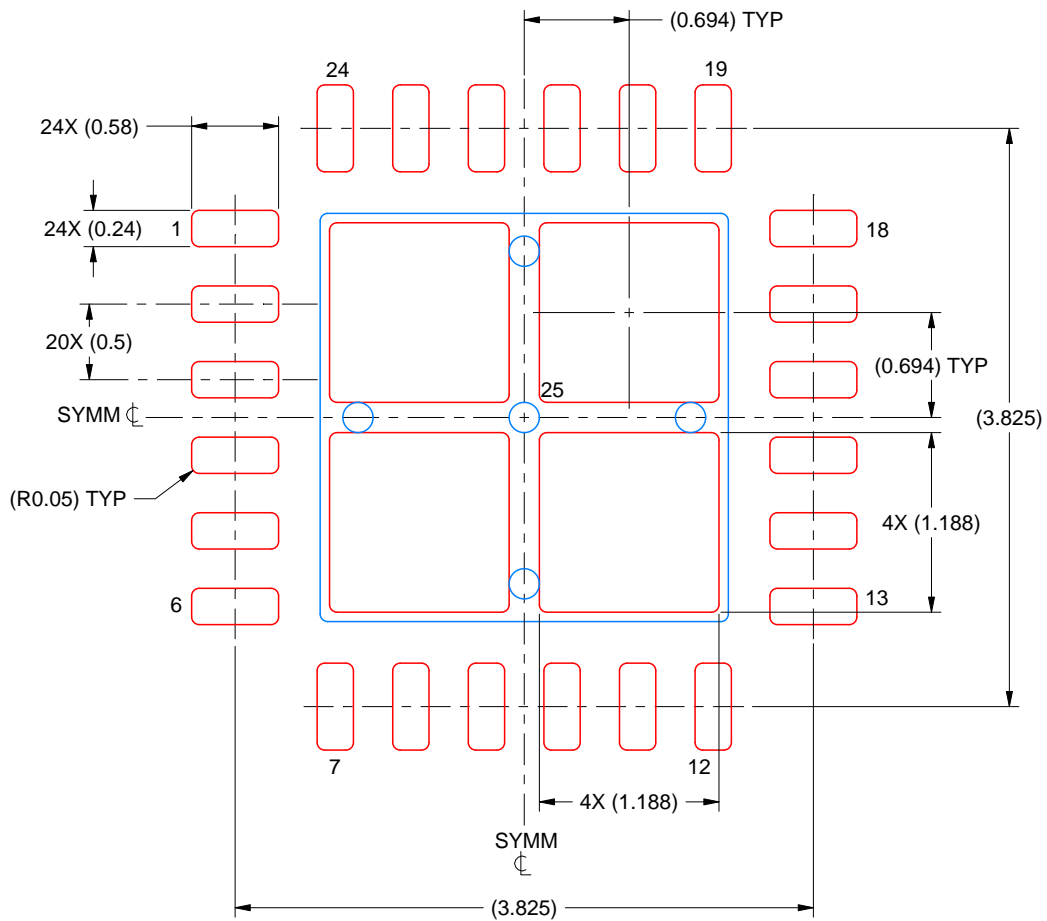

SOLDER PASTE EXAMPLE
BASED ON 0.125 MM THICK STENCIL
SCALE: 20X

EXPOSED PAD 25
77% PRINTED SOLDER COVERAGE BY AREA UNDER PACKAGE

4228221/A 11/2021

NOTES: (continued)

6. Laser cutting apertures with trapezoidal walls and rounded corners may offer better paste release. IPC-7525 may have alternate design recommendations.

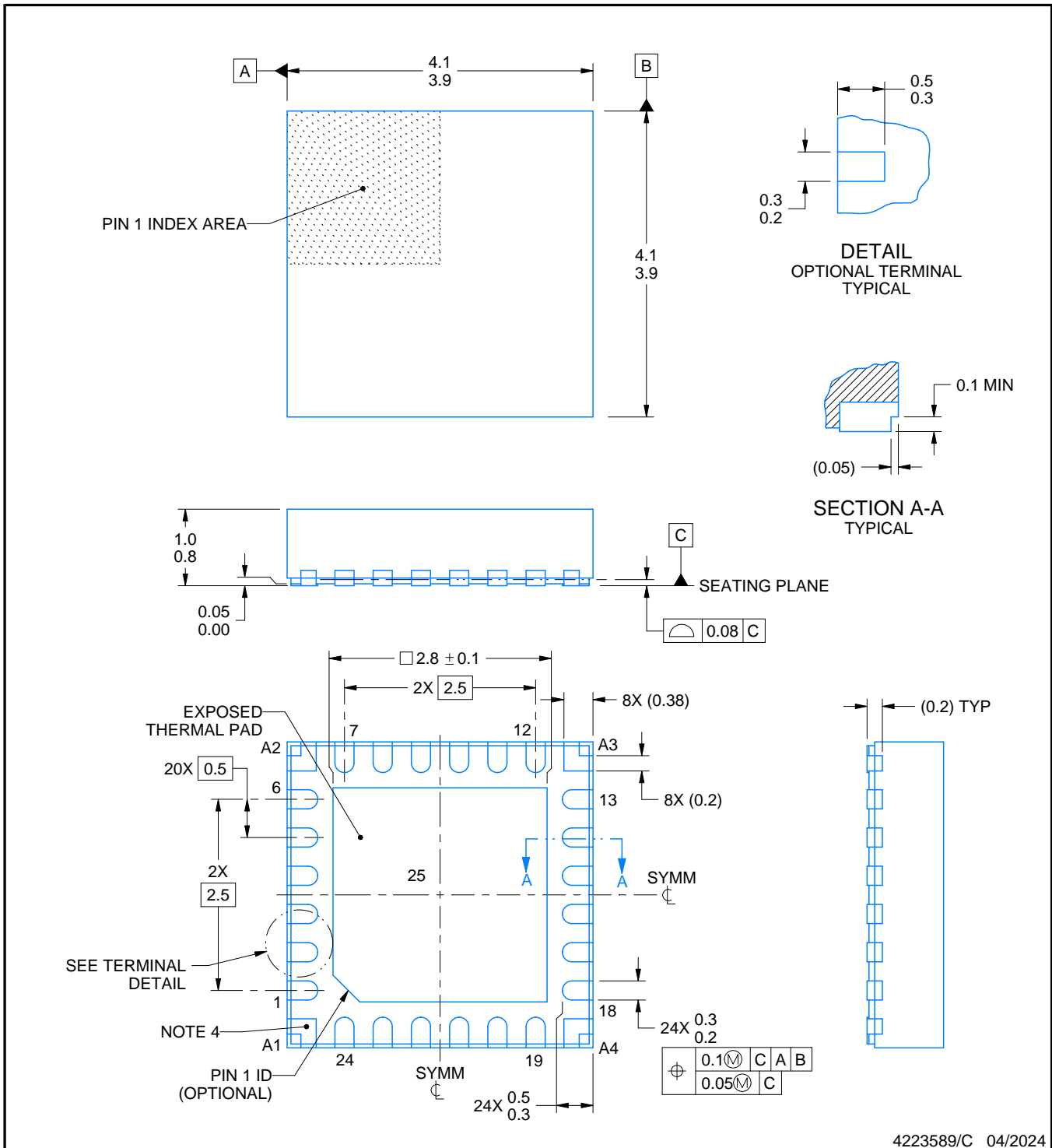
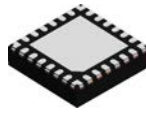

4223589/C 04/2024

NOTES:

1. All linear dimensions are in millimeters. Any dimensions in parenthesis are for reference only. Dimensioning and tolerancing per ASME Y14.5M.
2. This drawing is subject to change without notice.
3. The package thermal pad must be soldered to the printed circuit board for thermal and mechanical performance.
4. Corner pins A1-A4 are physically connected to exposed thermal pad internally. Soldering these is optional, but would require customer to supply land design and stencil.

EXAMPLE BOARD LAYOUT

RGE0024K

VQFN - 1 mm max height

PLASTIC QUAD FLATPACK - NO LEAD

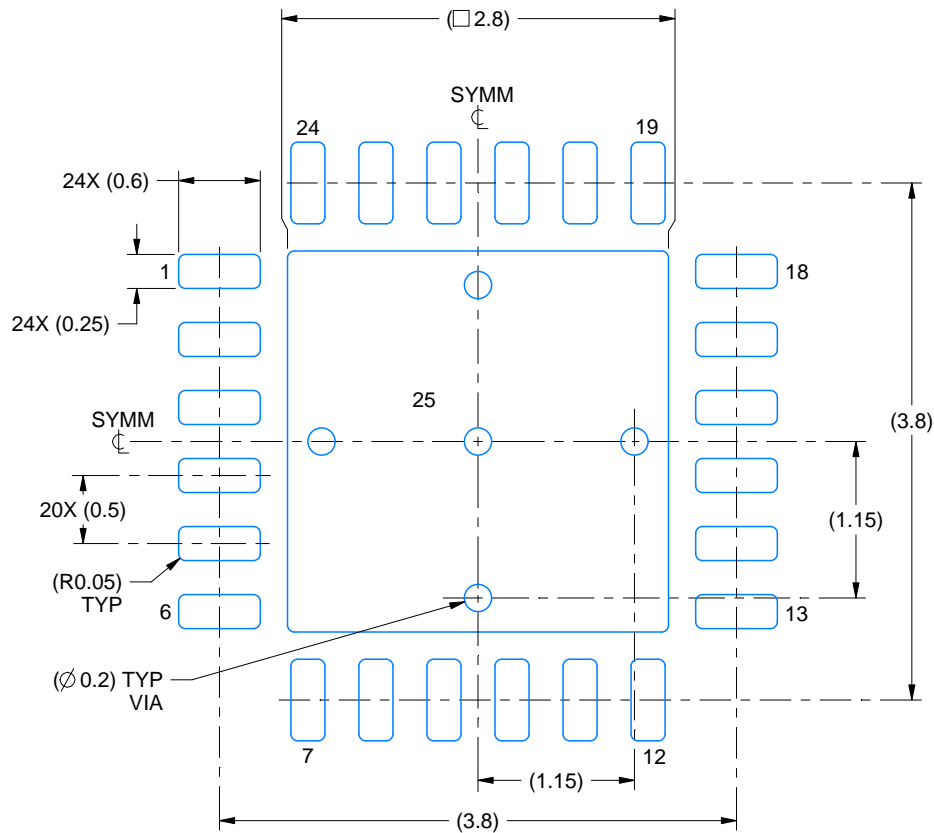

LAND PATTERN EXAMPLE
EXPOSED METAL SHOWN
SCALE:18X

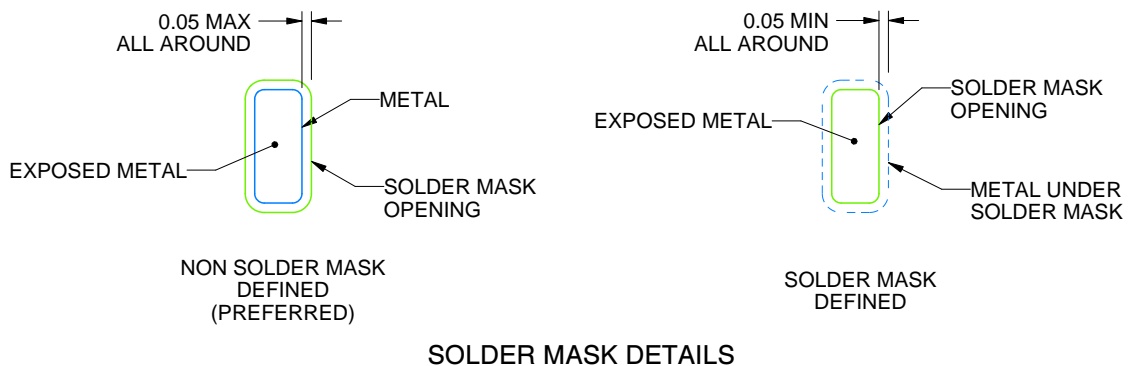

4223589/C 04/2024

NOTES: (continued)

- This package is designed to be soldered to a thermal pad on the board. For more information, see Texas Instruments literature number SLUA271 (www.ti.com/lit/sl原因271).
- Vias are optional depending on application, refer to device data sheet. If any vias are implemented, refer to their locations shown on this view. It is recommended that vias under paste be filled, plugged or tented.

EXAMPLE STENCIL DESIGN

RGE0024K

VQFN - 1 mm max height

PLASTIC QUAD FLATPACK - NO LEAD

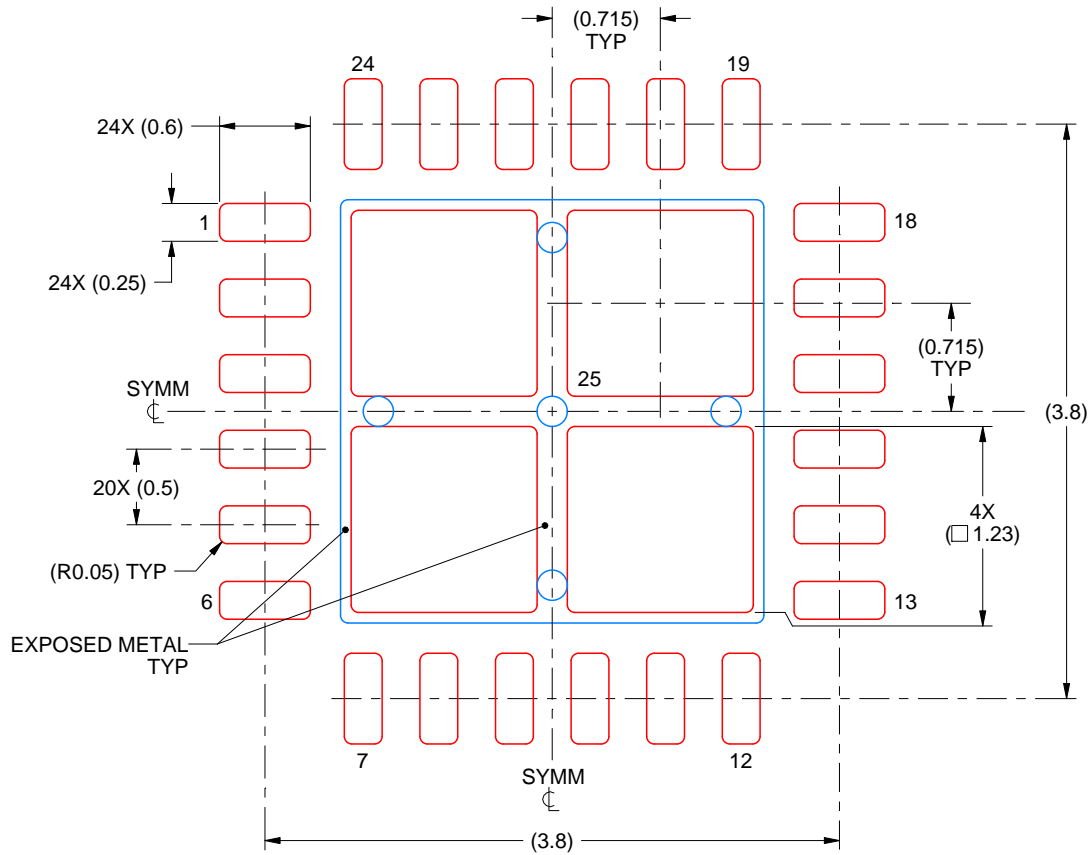

SOLDER PASTE EXAMPLE
BASED ON 0.1 mm THICK STENCIL

THERMAL PAD 25:
77% PRINTED SOLDER COVERAGE BY AREA UNDER PACKAGE
SCALE:20X

4223589/C 04/2024

NOTES: (continued)

7. Laser cutting apertures with trapezoidal walls and rounded corners may offer better paste release. IPC-7525 may have alternate design recommendations.

重要声明和免责声明

TI“按原样”提供技术和可靠性数据（包括数据表）、设计资源（包括参考设计）、应用或其他设计建议、网络工具、安全信息和其他资源，不保证没有瑕疵且不做任何明示或暗示的担保，包括但不限于对适销性、某特定用途方面的适用性或不侵犯任何第三方知识产权的暗示担保。

这些资源可供使用 TI 产品进行设计的熟练开发人员使用。您将自行承担以下全部责任：(1) 针对您的应用选择合适的 TI 产品，(2) 设计、验证并测试您的应用，(3) 确保您的应用满足相应标准以及任何其他功能安全、信息安全、监管或其他要求。

这些资源如有变更，恕不另行通知。TI 授权您仅可将这些资源用于研发本资源所述的 TI 产品的应用。严禁对这些资源进行其他复制或展示。您无权使用任何其他 TI 知识产权或任何第三方知识产权。您应全额赔偿因在这些资源的使用中对 TI 及其代表造成的任何索赔、损害、成本、损失和债务，TI 对此概不负责。

TI 提供的产品受 [TI 的销售条款](#) 或 [ti.com](#) 上其他适用条款/TI 产品随附的其他适用条款的约束。TI 提供这些资源并不会扩展或以其他方式更改 TI 针对 TI 产品发布的适用的担保或担保免责声明。

TI 反对并拒绝您可能提出的任何其他或不同的条款。

邮寄地址：Texas Instruments, Post Office Box 655303, Dallas, Texas 75265
Copyright © 2024，德州仪器 (TI) 公司