

TPS7H2140-SEP 抗辐射、32V、160mΩ 四通道电子保险丝

1 特性

- 提供供应商项目图，[VID V62/23610](#)
- 电离辐射总剂量 (TID) 为 30krad(Si)
 - 辐射批次验收测试 (RLAT) : 20krad(Si)
- 确定了单粒子效应 (SEE)
 - 单粒子锁定 (SEL)、单粒子烧毁 (SEB) 和单粒子栅穿 (SEGR) 对于线性能量传递 (LET) 的抗扰度为 43MeV-cm²/mg
 - 单粒子瞬变 (SET) 和单粒子功能中断 (SEFI) 对于有效线性能量传递 (LET) 的额定抗扰度为 43MeV-cm²/mg
- 具有丰富诊断功能和电流检测模拟输出的四通道 160mΩ 电子保险丝
- 宽工作电压范围：4.5V 至 32V
- 低于 500nA 的超低待机电流
- 高精度电流检测：当 $I_{LOAD} \geq 25mA$ 时为 $\pm 15\%$
- 可通过外部电阻器 (R_{CL}) 调节电流限制，且当 $I_{LOAD} \geq 500mA$ 时精度为 $\pm 15\%$
- 保护
 - 通过限制电流实现 GND 短路保护 (内部或外部)
 - 具有锁闭选项的热关断以及热调节
 - 压摆率经过优化的电感负载负电压钳位
 - 接地失效保护和掉电保护
- 诊断
 - 过流和接地短路检测
 - 开路负载和电源短路检测
 - 用于实现快速中断的全局故障报告
- 28 引脚热增强型 PWP 封装
- 增强型航天塑料 (SEP)
- 可用于军用温度范围 (-55°C 至 125°C)

2 应用

- 卫星电力系统 (EPS)
- 航天卫星电源管理和配电
- 抗辐射电源树应用
- 为受控上电和断电启用开关电源轨
- 驱动螺线管

3 说明

TPS7H2140-SEP 器件是一款集成四个 160mΩ NMOS 功率 FET 且受到全方位保护的 四通道智能高侧开关。

该器件具有丰富的诊断功能以及高精度电流检测功能，能够对负载实施智能控制。

该器件可从外部调节电流限值以限制浪涌或过载电流，从而提升整个系统的可靠性。

器件信息

器件型号 ⁽¹⁾	等级 ⁽²⁾	封装尺寸 ⁽⁴⁾
TPS7H2140MPWPTSEP	9 月	HTSSOP (28) 6.4mm × 9.7mm 质量 = 124mg ⁽³⁾
TPS7H2140EVM	评估模块	评估板

- 如需了解所有可用封装，请参阅数据表末尾的可订购产品附录。
- 有关器件等级的其他信息，请查看 [SLYB235](#)。
- 质量为标称值。
- 封装尺寸 (长 × 宽) 为标称值，不包括引脚。

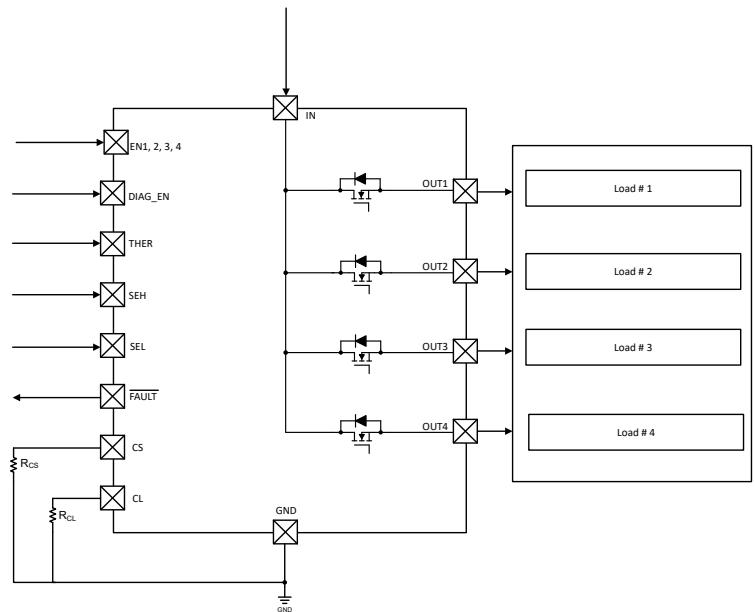

典型应用原理图



Table of Contents

1 特性	1	8.3 Feature Description.....	15
2 应用	1	8.4 Device Functional Modes.....	28
3 说明	1	9 Application and Implementation	30
4 Revision History	2	9.1 Application Information.....	30
5 Pin Configuration and Functions	3	9.2 Typical Application.....	30
6 Specifications	4	9.3 Power Supply Recommendations.....	32
6.1 Absolute Maximum Ratings.....	4	9.4 Layout.....	33
6.2 ESD Ratings.....	4	10 Device and Documentation Support	35
6.3 Recommended Operating Conditions.....	5	10.1 Documentation Support.....	35
6.4 Thermal Information.....	5	10.2 接收文档更新通知.....	35
6.5 Electrical Characteristics.....	5	10.3 支持资源.....	35
6.6 Switching Characteristics.....	7	10.4 Trademarks.....	35
6.7 Typical Characteristics.....	9	10.5 静电放电警告.....	35
7 Parameter Measurement Information	12	10.6 术语表.....	35
8 Detailed Description	13	11 Mechanical, Packaging, and Orderable Information	35
8.1 Overview.....	13		
8.2 Functional Block Diagram.....	14		

4 Revision History

注：以前版本的页码可能与当前版本的页码不同

Changes from Revision * (July 2023) to Revision A (October 2023)	Page
• 将文档状态从“预告信息”更改为“量产数据”	1

5 Pin Configuration and Functions



图 5-1. PWP Package
28-Pin HTSSOP With Exposed Thermal Pad
(Top View)

表 5-1. Pin Functions

PIN		I/O ⁽¹⁾	DESCRIPTION
NAME	NO.		
CL	11	O	Adjustable current limit. Connect to device GND if external current limit is not used.
CS	10	O	Current-sense output.
DIAG_EN	14	I	Enable-disable pin for diagnostics; internal pull-down.
FAULT	9	O	Global fault report with open-drain structure, ORed logic for quad-channel fault conditions.
GND	1, 12	—	Ground pin.
EN1	3	I	Input control for channel 1 activation; internal pull-down.
EN2	4	I	Input control for channel 2 activation; internal pull-down.
EN3	5	I	Input control for channel 3 activation; internal pull-down.
EN4	6	I	Input control for channel 4 activation; internal pull-down.
NC	2, 19, 24	—	No connect. This pin is not internally connected. It is recommended to connect this pin to GND to prevent charge buildup; however, this pin can also be left open or tied to any voltage between GND and IN.
SEH	7	I	CS channel-selection high bit; internal pull-down.
SEL	8	I	CS channel-selection low bit; internal pull-down.
THER	13	I	Thermal shutdown behavior control, latch off or auto-retry; internal pull-down.
OUT1	27, 28	O	Output of the channel 1 high side-switch, connected to the load.
OUT2	25, 26	O	Output of the channel 2 high side-switch, connected to the load.
OUT3	17, 18	O	Output of the channel 3 high side-switch, connected to the load.
OUT4	15, 16	O	Output of the channel 4 high side-switch, connected to the load.
IN	20, 21, 22, 23	I	Power supply.
Thermal pad	—	—	Connect to device GND or leave floating.

(1) I = Input, O = Other, — = Other

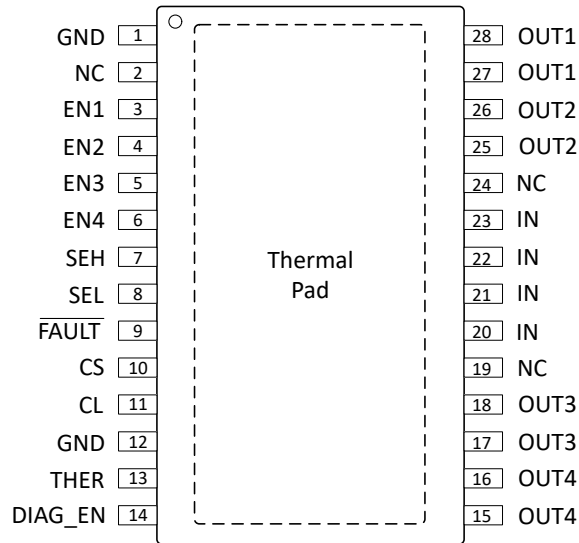
6 Specifications

6.1 Absolute Maximum Ratings

over operating free-air temperature range (unless otherwise noted) ⁽¹⁾ ⁽²⁾

		MIN	MAX	UNIT
Input voltage	IN (t < 400 ms)		48	V
	IN		35	
	Reverse polarity voltage ⁽³⁾	- 36		
	ENx, DIAG_EN, SEL, SEH, and THER	- 0.3	7	
	FAULT	- 0.3	7	
	CS	- 2.7	7	
	CL	- 0.3	7	
Input and output current	ENx, DIAG_EN, SEL, SEH, and THER pins	- 10		mA
	GND (t < 120 s)	- 100	250	
	FAULT	- 30	10	
	CS		30	
	CL		6	
Input energy	Inductive load switch-off energy dissipation, single pulse, single channel ⁽⁴⁾		40	mJ
Junction temperature	T _J	- 55	150	°C
Storage temperature	T _{stg}	- 65	150	

- (1) Operation outside the Absolute Maximum Ratings may cause permanent device damage. Absolute Maximum Ratings do not imply functional operation of the device at these or any other conditions beyond those listed under Recommended Operating Conditions. If used outside the Recommended Operating Conditions but within the Absolute Maximum Ratings, the device may not be fully functional, and this may affect device reliability, functionality, performance, and shorten the device lifetime.
- (2) All voltage values are with respect to GND.
- (3) Reverse polarity condition: time t < 60 s, reverse current < I_{R2}, V_{ENx} = 0 V, GND pin 1-kΩ resistor in parallel with diode.
- (4) Test condition: V_{IN} = 13.5 V, L = 8 mH, R = 0 Ω, T_J = 150°C. FR4 2s2p board, 2 × 70-μm Cu, 2 × 35-μm Cu. 600 mm² thermal pad copper area.

6.2 ESD Ratings

			VALUE	UNIT	
V _(ESD)	Electrostatic discharge	Human body model (HBM), per ANSI/ESDA/JEDEC JS-001 ⁽¹⁾	IN and VOUTx with respect to GND	±4000	V
		Human body model (HBM), per ANSI/ESDA/JEDEC JS-001 ⁽¹⁾	All pins except IN and VOUTx	±2000	
		Charged device model (CDM), per ANSI/ESDA/JEDEC JS-002, all pins ⁽²⁾	All pins	±750	

- (1) JEDEC document JEP155 states that 500-V HBM allows safe manufacturing with a standard ESD control process.
- (2) JEDEC document JEP157 states that 250-V CDM allows safe manufacturing with a standard ESD control process.

6.3 Recommended Operating Conditions

over operating free-air temperature range (unless otherwise noted) ⁽¹⁾

		MIN	MAX	UNIT
Input voltage	IN ⁽¹⁾	4.5	32	V
	ENx, DIAG_EN, SEL, SEH, and THER	0	5	
	FAULT	0	5	
Output current	OUTx ⁽³⁾	0	1.35	A
Ambient temperature	T _A	- 55	125	°C

- (1) All voltage values are with respect to GND.
- (2) Transients up to the absolute maximum is allowed.
- (3) All channel on.

6.4 Thermal Information

THERMAL METRIC ⁽¹⁾		TPS7H2140-SEP	UNIT
		HTSSOP (PWP)	
		28 PINS	
R _{θJA}	Junction-to-ambient thermal resistance	27	°C/W
R _{θJC(top)}	Junction-to-case (top) thermal resistance	20.3	
R _{θJB}	Junction-to-board thermal resistance	8	
ψ _{JT}	Junction-to-top characterization parameter	0.2	
ψ _{JB}	Junction-to-board characterization parameter	8	
R _{θJC(bot)}	Junction-to-case (bottom) thermal resistance	1.1	

- (1) For more information about traditional and new thermal metrics, see the *IC Package Thermal Metrics* application report, [SPRA953](#).

6.5 Electrical Characteristics

over 4.5 V ≤ V_{IN} ≤ 32 V, temperature range (-55°C ≤ T_A ≤ 125°C), unless otherwise specified ⁽¹⁾

PARAMETER		TEST CONDITIONS	MIN	TYP	MAX	UNIT
OPERATING VOLTAGE						
IN _{UVLOR}	Internal V _{IN} UVLO rising		3.5	3.7	4	V
IN _{UVLOF}	Internal V _{IN} UVLO falling		3	3.2	3.4	
HYST _{IN-UVLO}	Internal V _{IN} UVLO hysteresis			0.5		
OPERATING CURRENT						
I _Q	Quiescent current with diagnostics disabled	ENx = 5 V, DIAG_EN = 0 V, I _{OUTx} = 0 A, current limit = 2 A, all channels on			7.0	mA
I _{Q_DIAG}	Quiescent current with diagnostics enabled	ENx = DIAG_EN = 5 V, I _{OUTx} = 0 A, current limit = 2 A, all channels on			6.2	
I _{SD}	Shutdown current with diagnostics disabled	ENx = DIAG_EN = OUTx = THER = 0 V		T _A =25°C	0.5	µA
				T _A =125°C	5	
I _{SD_DIAG}	Shutdown current with diagnostic enabled	ENx = 0 V, DIAG_EN = 5 V, V _{IN} - V _{OUTx} < V _{OL_OFF} , not in open-load mode			5	mA
t _{LOW_OFF}	ENx signal low time during cycling	ENx from high to low, if elapsed time > t _{LOW_OFF} , the device enters into standby mode	10	12.5	15	ms
I _F	IN to OUTx forward leakage current	ENx = DIAG_EN = OUTx = 0		T _A = 25°C	0.5	µA
		ENx = DIAG_EN = OUTx = 0		T _A = 125°C	8	

6.5 Electrical Characteristics (续)

over $4.5\text{ V} \leq V_{IN} \leq 32\text{ V}$, temperature range ($-55^\circ\text{C} \leq T_A \leq 125^\circ\text{C}$), unless otherwise specified ⁽¹⁾

PARAMETER		TEST CONDITIONS	MIN	TYP	MAX	UNIT
POWER STAGE						
R _{ON}	On-state resistance	T _A = 25°C	165			mΩ
		T _A = 125°C	280			
ΔR _{ON}	Percentage Difference in On-state resistance between channels (R _{ON_CHX} - R _{ON_CHY})	T _A = 25°C	6%			
I _{CL_INTERNAL}	Internal current limit	Internal current limit value, CL pin connected to GND	11			A
I _{CL_INTERNAL_TSD}	Current limit during thermal shutdown	Internal current limit value under thermal shutdown	6.5			
I _{CL_TSD}	Current limit during thermal shutdown	External current limit value under thermal shutdown. The percentage of the external current limit setting value	70%			
V _{DS_CLAMP}	Source-to-drain body diode voltage		50	70		V
OUTPUT DIODE CHARACTERISTICS						
V _F	Drain-source diode voltage	ENx = 0, I _{OUTX} = -0.15 A.	0.3	0.7	0.9	V
I _{R1}	Continuous reverse current from source to drain	t < 60 s, V _{IN} = 24 V, ENx = 0 V. Single channel reversed current to supply	T _A = 25°C		2.5	A
I _{R2}	Continuous reverse current from source to drain	t < 60 s, V _{IN} = 24 V, ENx = 0 V. GND pin 1-kΩ resistor in parallel with diode. Reverse-current condition, All channels reversed	T _A = 25°C		2.0	
LOGIC INPUT (ENx, DIAG_EN, SEL, SEH, THER)						
V _{IH}	Logic high-level voltage		2			V
V _{IL}	Logic low-level voltage		0.8			
R _{PULL_DOWN}	Logic-pin pulldown resistor	V _{IN} = V _{DIAG_EN} = 5 V	200	275	350	kΩ
		V _{IN} = V _{ENx} = V _{SEL} = V _{SEH} = V _{THER} = 5 V	100	175	250	
DIAGNOSTICS						
I _{GND_LOSS}	Output leakage current under GND loss condition		100			μA
V _{OL_OFF}	Open load detection threshold	V _{ENx} = 0 V, when V _{IN} - V _{OUTX} > V _{OL_OFF} . Duration longer than t _{OL_OFF} , then open load is detected, off state.	1.6	2.6		V
t _{OL_OFF}	Open-load detection threshold deglitch time	V _{ENx} = 0 V, when V _{IN} - V _{OUTX} > V _{OL_OFF} . Duration longer than t _{OL_OFF} , then open load is detected, off state	300	550	800	μs
I _{OL_OFF}	Off-state output sink current	V _{ENx} = 0 V, V _{DIAG_EN} = 5 V, V _{IN} - V _{OUTX} = 24 V, open load	T _A = 125°C		100	μA
V _{OL_FAULT}	Fault low-output voltage	I _{FAULT} = 2 mA	0.2			V
t _{CL_DEGLITCH}	Deglitch time when current limit occurs	ENx = DIAG_EN = 5 V. The deglitch time from current limit event to FAULT = Low and V _{CS_FAULT}	220			μs
T _{SD}	Thermal shutdown threshold		160	175		°C
T _{SD_RST}	Thermal shutdown status reset threshold		155			
T _{sw}	Thermal swing shutdown threshold		60			
T _{HYS}	Hysteresis for resetting the thermal shutdown or thermal swing		10			
CURRENT SENSE AND CURRENT LIMIT						
K _{CS}	Current sense ratio		300			
K _{CL}	Current limit ratio		2500			
V _{CL_TH}	Current limit internal threshold voltage ⁽³⁾		0.8			V

6.5 Electrical Characteristics (续)

over $4.5\text{ V} \leq V_{IN} \leq 32\text{ V}$, temperature range $(-55^\circ\text{C} \leq T_A \leq 125^\circ\text{C})$, unless otherwise specified ⁽¹⁾

PARAMETER		TEST CONDITIONS	MIN	TYP	MAX	UNIT
dK _{CS} / K _{CS}	Current sense accuracy, $(I_{CS} \times K_{CS} - I_{OUT}) / I_{OUT} \times 100$	$V_{IN} = 13.5\text{ V}, I_{OUTx} \geq 5\text{ mA}$	-65%		65%	
dK _{CS} / K _{CS}		$V_{IN} = 13.5\text{ V}, I_{OUTx} \geq 25\text{ mA}$	-15%		15%	
dK _{CS} / K _{CS}		$V_{IN} = 13.5\text{ V}, I_{OUTx} \geq 50\text{ mA}$	-8%		8%	
dK _{CS} / K _{CS}		$V_{IN} = 13.5\text{ V}, I_{OUTx} \geq 100\text{ mA}$	-4%		4%	
dK _{CL} / K _{CL}	External current limit accuracy, $(I_{OUTx} - I_{CL} \times K_{CL}) \times 100 / (I_{CL} \times K_{CL})$	$V_{IN} = 13.5\text{ V}, I_{LIMIT} \geq 250\text{ mA}$	-20%		20%	
dK _{CL} / K _{CL}		$V_{IN} = 13.5\text{ V}, 2\text{ A} \leq I_{LIMIT} \leq 4\text{ A}$	-15%		15%	
V _{CS_LINEAR}	Current-sense voltage linear range	$V_{IN} \geq 6.5\text{ V}$	0		4	V
		$5\text{ V} \leq V_{IN} < 6.5\text{ V}$	0		$V_{IN} - 2.5$	
I _{OUTx_LINEAR}	Output-current linear range	$V_{IN} \geq 6.5\text{ V}, V_{CS_LINEAR} \leq 4\text{ V}$	0		2.5	A
		$5\text{ V} \leq V_{IN} < 6.5\text{ V}, V_{CS_LINEAR} \leq V_{IN} - 2.5\text{ V}$	0		2.5	
V _{CS_FAULT}	Current sense pin output voltage	$V_{IN} \geq 7\text{ V}, \text{FAULT mode}$	4.5		6.5	V
		$5\text{ V} \leq V_{IN} < 7\text{ V}, \overline{\text{FAULT}} \text{ mode}$	$\text{Min}(V_{IN} - 2.3, 4.5)$		6.5	
I _{CS_FAULT}	Current-sense pin output current available in fault mode	$V_{CS} = 4.5\text{ V}, V_{IN} > 7\text{ V}$	15			mA
I _{CS_LEAK}	Current-sense leakage current in disabled mode	$V_{DIAG_EN} = 0\text{ V}$				$T_A = 125^\circ\text{C}$ 0.5 μA

- (1) All voltage values are with respect to GND.
(2) V_{CL_TH} tolerance is included in the dK_{CL} / K_{CL} tolerance.

6.6 Switching Characteristics

PARAMETER		TEST CONDITIONS	MIN	TYP	MAX	UNIT
POWER STAGE						
t _{ON}	Turn-on delay time	$V_{IN} = 13.5\text{ V}, V_{DIAG_EN} = 5\text{ V}, I_{OUTx} = 500\text{ mA}$, from ENx rising edge to 10% of V _{OUTx}	20	50	90	μs
t _{OFF}	Turn-off delay time	$V_{IN} = 13.5\text{ V}, V_{DIAG_EN} = 5\text{ V}, I_{OUTx} = 500\text{ mA}$, from ENx falling edge to 90% of V _{OUTx}	20	50	90	
t _{RISE}	Channel turn-on time	$V_{IN} = 13.5\text{ V}, V_{DIAG_EN} = 5\text{ V}, I_{OUTx} = 500\text{ mA}$, from 50% of ENx to 90% of V _{OUTx}	66	88	125	
t _{FALL}	Channel turn-off time	$V_{IN} = 13.5\text{ V}, V_{DIAG_EN} = 5\text{ V}, I_{OUTx} = 500\text{ mA}$, from 50% of ENx to 10% of V _{OUTx}	66	88	125	
t _{MATCH}	t _{RISE} - t _{FALL}	$V_{IN} = 13.5\text{ V}, I_{OUT} = 500\text{ mA}$. t _{RISE} is the ENx rising edge to V _{OUTx} = 90%. t _{FALL} is the ENx falling edge to V _{OUTx} = 10%.	-50		50	
SR _{ON}	Turn-on slew rate	$V_{IN} = 13.5\text{ V}, V_{DIAG_EN} = 5\text{ V}, I_{OUTx} = 500\text{ mA}$, from ENx rising edge to 10% of V _{OUTx}	0.1	0.3	0.55	V/μs
SR _{OFF}	Turn-off slew rate	$V_{IN} = 13.5\text{ V}, V_{DIAG_EN} = 5\text{ V}, I_{OUTx} = 500\text{ mA}$, from ENx falling edge to 90% of V _{OUTx}	0.1	0.3	0.55	
CURRENT SENSE						

6.6 Switching Characteristics (续)

PARAMETER		TEST CONDITIONS	MIN	TYP	MAX	UNIT
t_{CS_OFF1}	CS settling time from DIAG_EN disabled	$V_{IN} = 13.5\text{ V}$, $V_{ENx} = 5\text{ V}$, $I_{OUTx} = 500\text{ mA}$. Current Limit = 2 A. From V_{DIAG_EN} falling edge to 10% of V_{CS} .			20	μs
t_{CS_ON1}	CS settling time from DIAG_EN enabled	$V_{IN} = 13.5\text{ V}$, $V_{ENx} = 5\text{ V}$, $I_{OUTx} = 500\text{ mA}$. Current Limit = 2 A. From V_{DIAG_EN} rising edge to 90% of V_{CS} .			20	
t_{CS_OFF2}	CS settling time from IN falling edge	$V_{IN} = 13.5\text{ V}$, $V_{ENx} = 5\text{ V}$, $I_{OUTx} = 500\text{ mA}$. Current Limit = 2 A. From V_{ENx} falling edge to 10% of V_{CS} .	30		100	
t_{CS_ON2}	CS settling time from IN rising edge	$V_{IN} = 13.5\text{ V}$, $V_{ENx} = 5\text{ V}$, $I_{OUTx} = 500\text{ mA}$. Current Limit = 2 A. From V_{ENx} rising edge to 90% of V_{CS} .	50		150	
t_{MUX}	Multi-sense transition delay from channel to channel	$V_{DIAG_EN} = 5\text{ V}$, current sense output delay when multi-sense pins SEL and SEH transition from channel to channel			50	

6.7 Typical Characteristics



图 6-1. ENx Voltage Threshold



图 6-2. EN1 Voltage Threshold vs V_{IN}

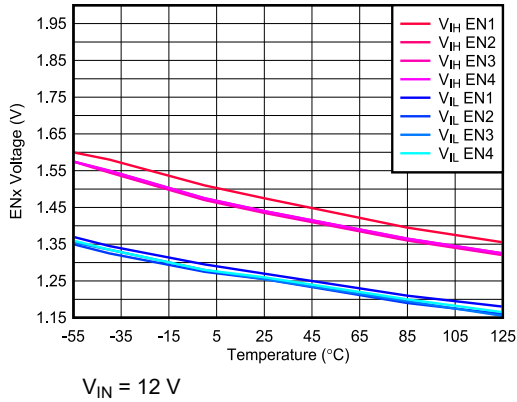

图 6-3. DIAG_EN Voltage Threshold

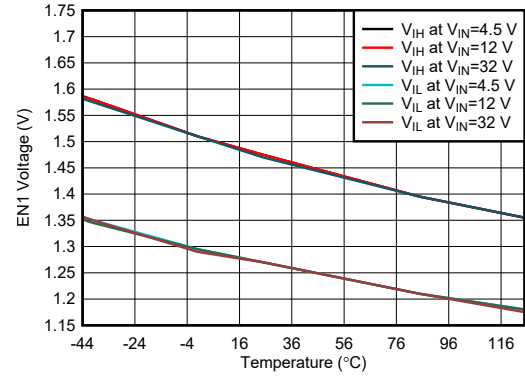

图 6-4. SEH,SEL Voltage Threshold

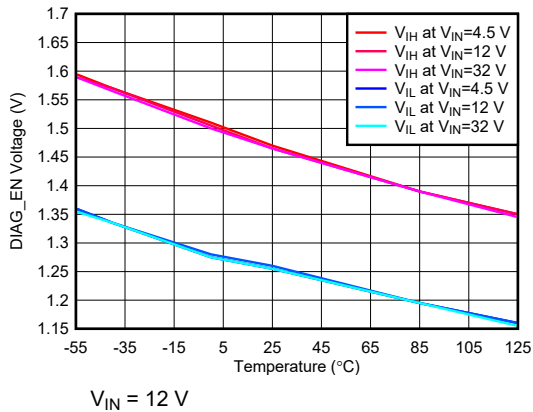

图 6-5. SEH Voltage Threshold vs V_{IN}

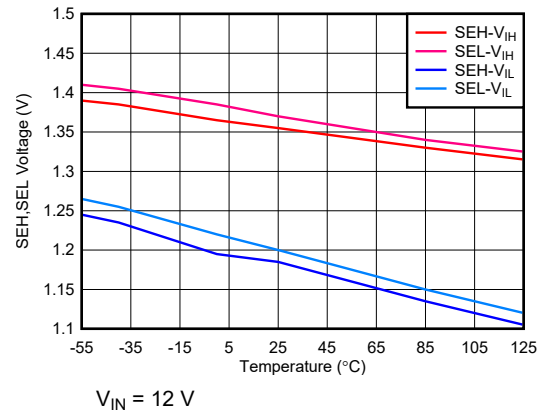

图 6-6. Body-Diode Forward Voltage

6.7 Typical Characteristics (continued)

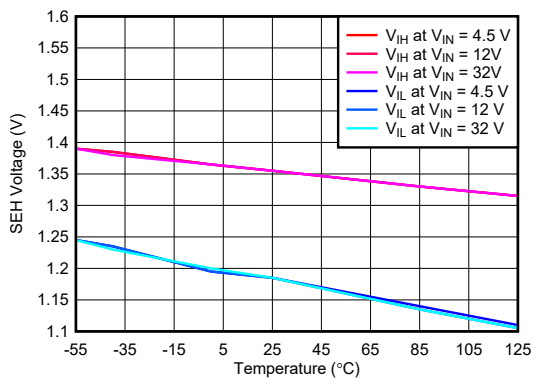

图 6-7. Drain-to-Source Clamp Voltage

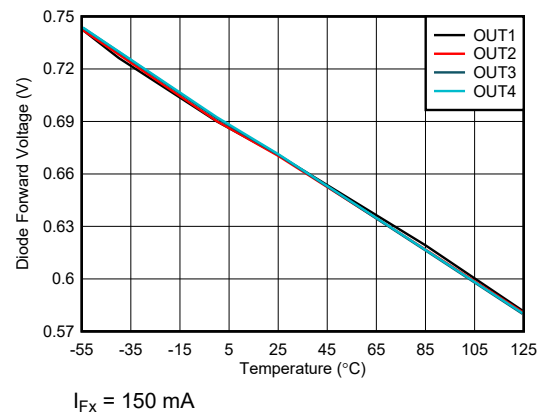

I_{OUT1} = 490 mA

图 6-8. Channel-1 FET On-Resistance

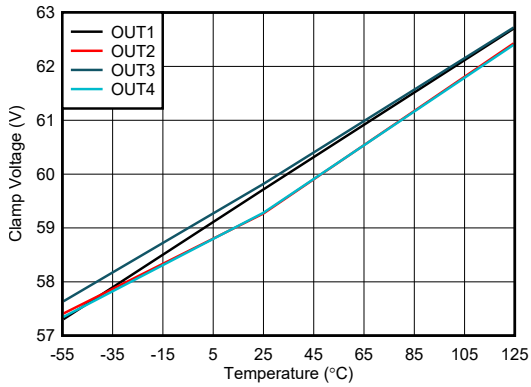
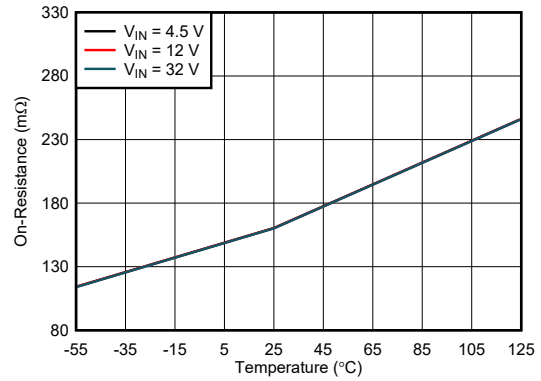
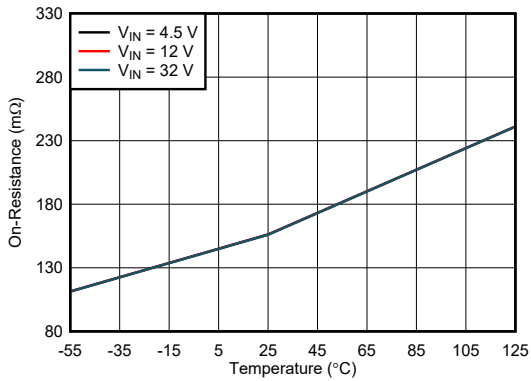

I_{OUT2} = 490 mA

图 6-9. Channel-2 FET On-Resistance

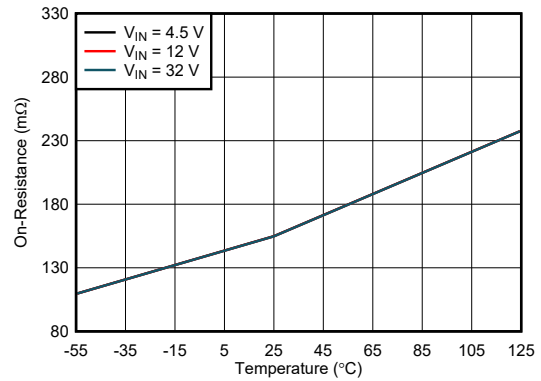

I_{OUT3} = 490 mA

图 6-10. Channel-3 FET On-Resistance

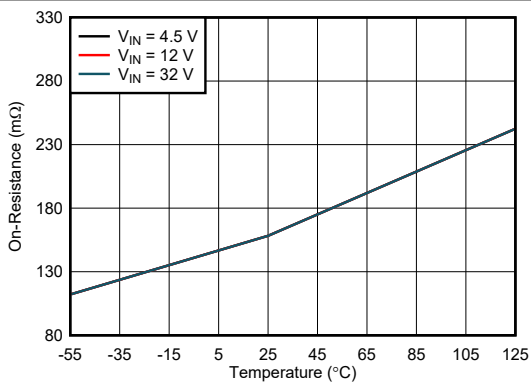

I_{OUT4} = 490 mA

图 6-11. Channel-4 FET On-Resistance



图 6-12. Current-Sense Ratio at 5 mA

6.7 Typical Characteristics (continued)



图 6-13. Current-Sense Ratio at 25 mA

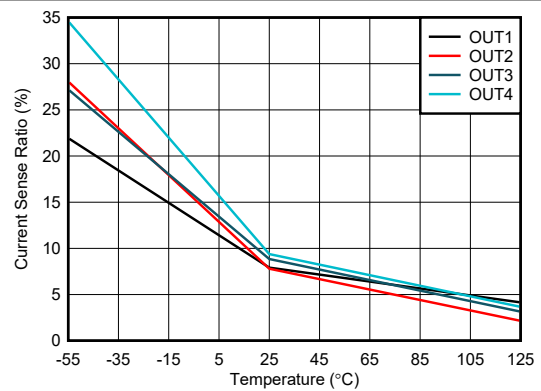

图 6-14. Current-Sense Ratio at 50 mA

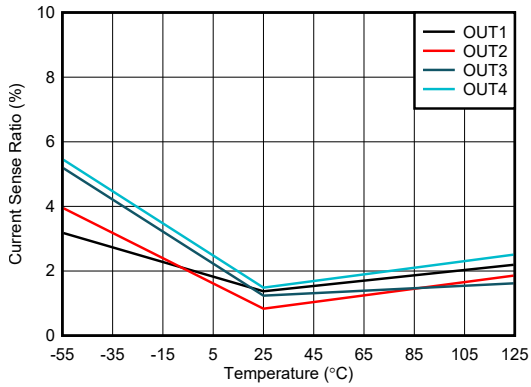

图 6-15. Current-Sense Ratio at 100 mA

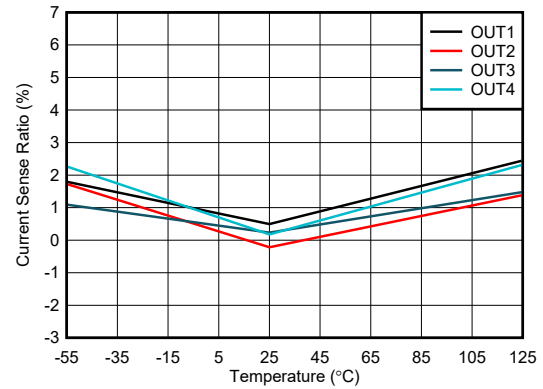

图 6-16. Current-Sense Ratio at 500 mA

7 Parameter Measurement Information

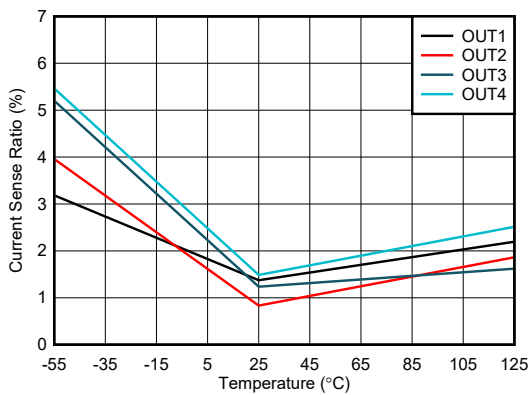

图 7-1. Output Delay Characteristics

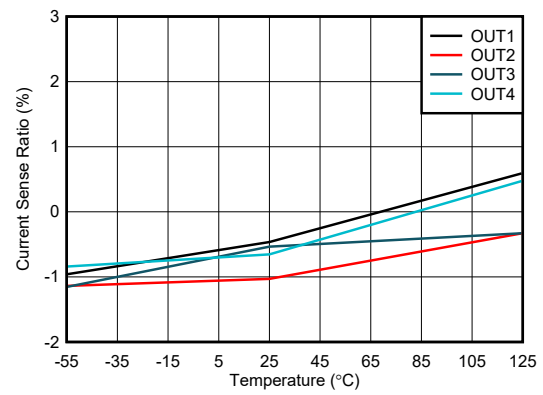

图 7-2. CS Delay Characteristics

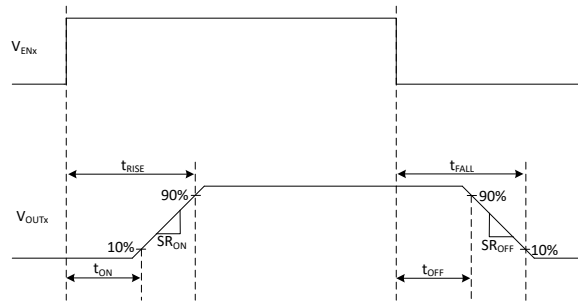

图 7-3. Open-Load Blanking-Time Characteristics

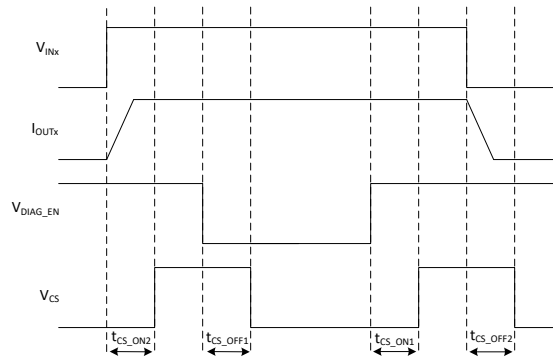

图 7-4. Multi-sense Transition Delay

8 Detailed Description

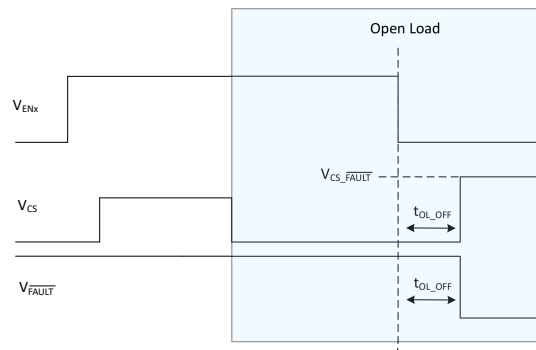
8.1 Overview

The TPS7H2140-SEP device is a eFuse, with internal charge pump and quad-channel integrated NMOS power FETs. Full diagnostics and high-accuracy current-sense features enable intelligent control of the load. The adjustable current-limit function greatly improves the reliability of whole system. The device includes diagnostic reporting, which includes an global open-drain digital output and the current-sense analog output.

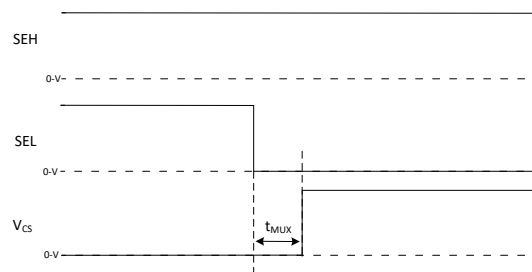
High-accuracy current sense makes the diagnostics more accurate without further calibration. One integrated current mirror can source $1 / K_{CS}$ of the load current. The mirrored current flows into the CS-pin resistor to become a voltage signal. K_{CS} is a constant value (300) across temperature and supply voltage. A wide linear region from 0 V to 4 V allows a better real-time load-current monitoring. The CS pin can also report a fault with pullup voltage of V_{CS_FAULT} .

The external high-accuracy current limit allows setting the current-limit value by applications. When overcurrent occurs, the device improves system reliability by clamping the inrush current effectively. The device can also save system area by reducing the size of PCB traces and connectors, and the capacity of the preceding power stage. Additional, the device also implements an internal current limit ($I_{CL_INTERNAL}$) with a fixed value, between 8 to 14 A.

For inductive loads (relays, solenoids, valves), the device implements an active clamp between drain and source to protect itself. During the inductive switching-off cycle, both the energy of the power supply and the load are dissipated on the high-side switch. The device also optimizes the switching-off slew rate when the clamp is active, which helps the system design by keeping the effects of transient power and EMI to a minimum.

The TPS7H2140-SEP device is a eFuse for a wide variety of resistive, inductive, and capacitive loads, including: relays, solenoids, heaters, and sub-modules.

8.2 Functional Block Diagram

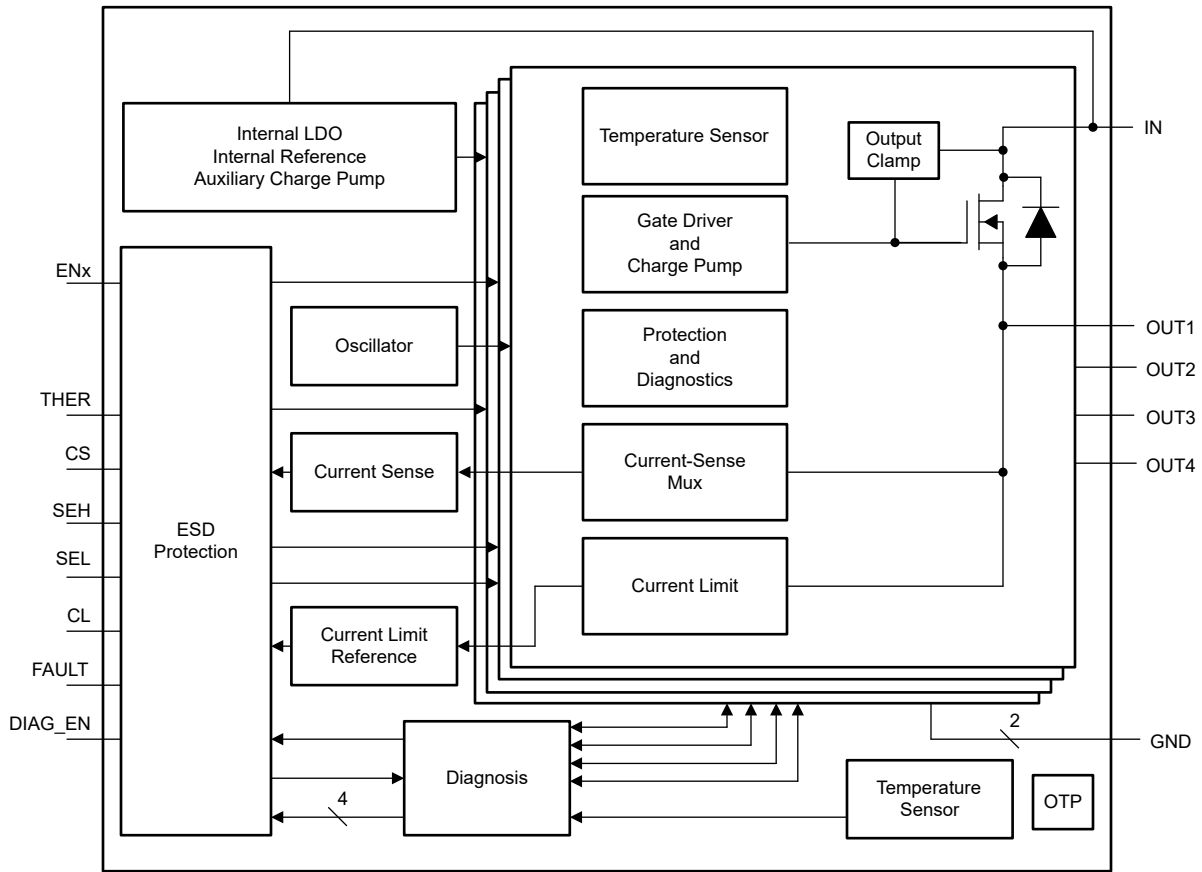

8.3 Feature Description

8.3.1 Pin Current and Voltage Conventions

For reference purposes throughout the data sheet, current directions on their respective pins are as shown by the arrows in [图 8-1](#). All voltages are measured relative to the ground plane.



图 8-1. Voltage and Current Conventions

8.3.2 Accurate Current Sense

High-accuracy current sense is implemented in the TPS7H2140-SEP. It allows a better real-time monitoring effect and more-accurate diagnostics without further calibration.

The integrated current mirror sources a ratio of the load current as: $1 / K_{CS}$ (where: $K_{CS} = 300$). This mirrored current flows into the external current sense resistor to become a voltage signal. The current mirror is shared by the four channels. Channel selection is accomplished by using the multiplexer digital inputs (SEL and SEH). I_{CS} can be calculated using [方程式 1](#).

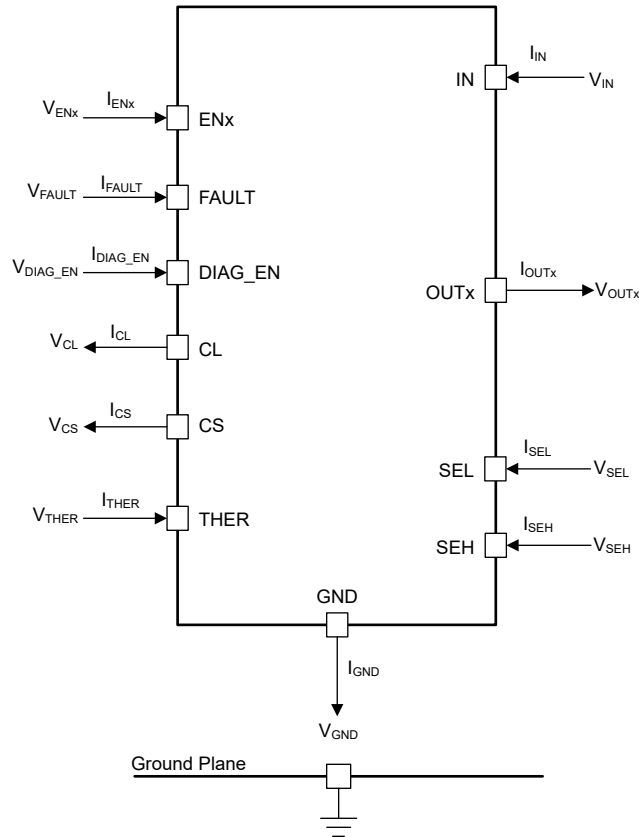
$$I_{CS} = \frac{I_{OUTx}}{K_{CS}} = \frac{I_{OUTx}}{300} \quad (1)$$

K_{CS} is the ratio of the output current and the sense current (CS). It is a constant value across the temperature and supply voltage (IN). Each device is calibrated accurately during production, so post-calibration is not required. See [图 8-2](#) for more details.



图 8-2. Current-Sense Block Diagram

When a fault occurs, the CS pin also works as a fault report with a pullup voltage of V_{CS_FAULT} . During a fault the maximum available current in CS is I_{CS_FAULT} (15 mA). See 图 8-3 for more details.

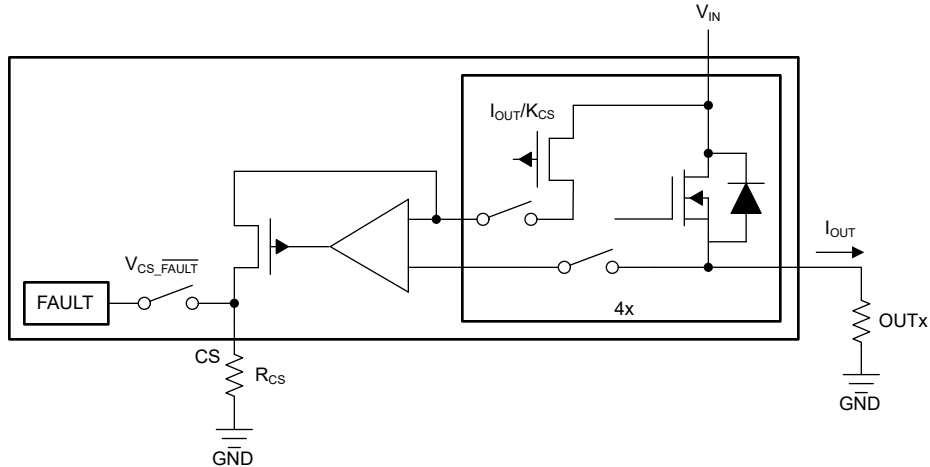

图 8-3. Current-Sense Output-Voltage Curve

Use 方程式 2 to calculate R_{CS} .

$$R_{CS} = \frac{V_{CS}}{I_{CS}} = \frac{V_{CS} \times K_{CS}}{I_{OUTx}} \quad (2)$$

Take the following points into consideration when calculating R_{CS} .

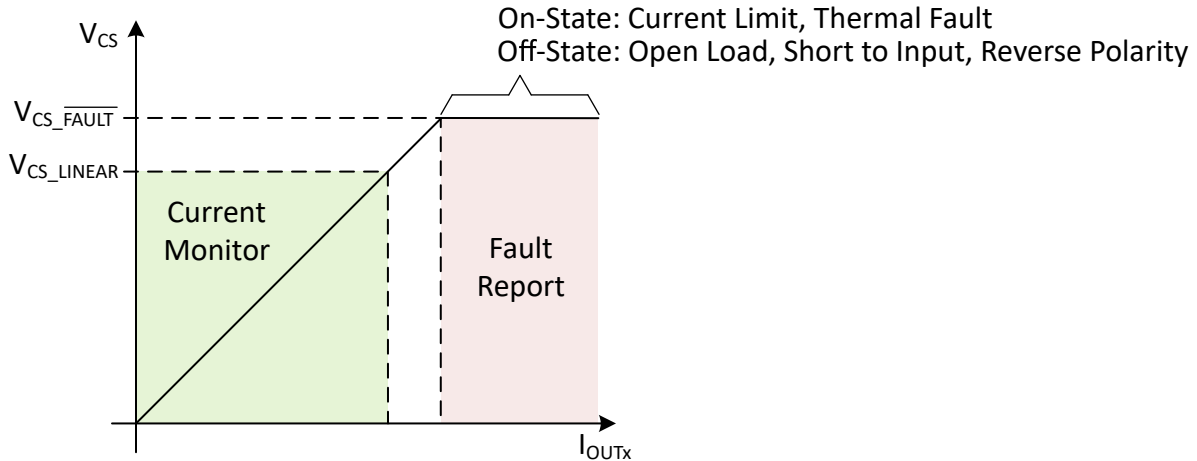
- Ensure V_{CS} is within the current-sense linear region (V_{CS_LINEAR} , I_{OUTx_LINEAR}) across the full range of the load current. Check R_{CS} with 方程式 3.

$$R_{CS} = \frac{V_{CS}}{I_{CS}} \leq \frac{V_{CS_LINEAR(MAX)} \times K_{CS}}{I_{OUTx(MAX)}} \quad (3)$$

- In fault mode, ensure I_{CS} is within the source capacity of the CS pin (I_{CS_FAULT}). Check R_{CS} with 方程式 4 .

$$R_{CS} = \frac{V_{CS}}{I_{CS}} \geq \frac{V_{CS_FAULT(MAX)}}{I_{CS_FAULT(MIN)}} \quad (4)$$

8.3.3 Adjustable Current Limit

A high-accuracy current limit allows high reliability of the design. It protects the load and the power supply from overstressing during short-circuit-to-GND or power-up conditions. The current limit can also save system cost by reducing the size of PCB traces and connectors, and the capacity of the preceding power stage.

When a current-limit threshold is hit, a closed loop activates immediately. The output current is clamped at the set value, and a fault is reported out. The device heats up due to the high power dissipation on the power FET. If thermal shutdown occurs, the current limit is set to I_{CL_TSD} (if set externally) or $I_{CL_INTERNAL_TSD}$ (when using internal) to reduce the power dissipation on the power FET. See [图 8-4](#) for more details.

The device has two current-limit thresholds.

- **Internal current limit** - The internal current limit is fixed at $I_{CL_INTERNAL}$, typically 11 A. Tie the CL pin directly to the device GND for large-transient-current applications.
- **External adjustable current limit** - An external resistor is used to set the current-limit threshold. Use the [方程式 5](#) and [方程式 6](#) to calculate the R_{CL} . V_{CL_TH} (0.8 V) is the internal band-gap voltage. K_{CL} (2500) is the ratio of the output current and the current-limit set value. It is constant across the temperature and supply voltage. The external adjustable current limit allows the flexibility to set the current limit value by applications.

$$I_{CL} = \frac{V_{CL_TH}}{R_{CL}} = \frac{I_{OUT}}{K_{CL}} \quad (5)$$

$$R_{CL} = \frac{V_{CL_TH} \times K_{CL}}{I_{OUT}} \quad (6)$$



图 8-4. Current-Limit Block Diagram

Note that if using a GND network which causes a level shift between the device GND and board GND, the CL pin must be connected with device GND.

For better protection from a hard short-to-GND condition (when the ENx pins are enabled, a short to GND occurs suddenly), the device implements a fast-trip protection to turn off the related channel before the current-limit closed loop is set up. The fast-trip response time is less than 1 μ s, typically. With this fast response, the device can achieve better inrush current-suppression performance.

8.3.4 Inductive-Load Switching-Off Clamp

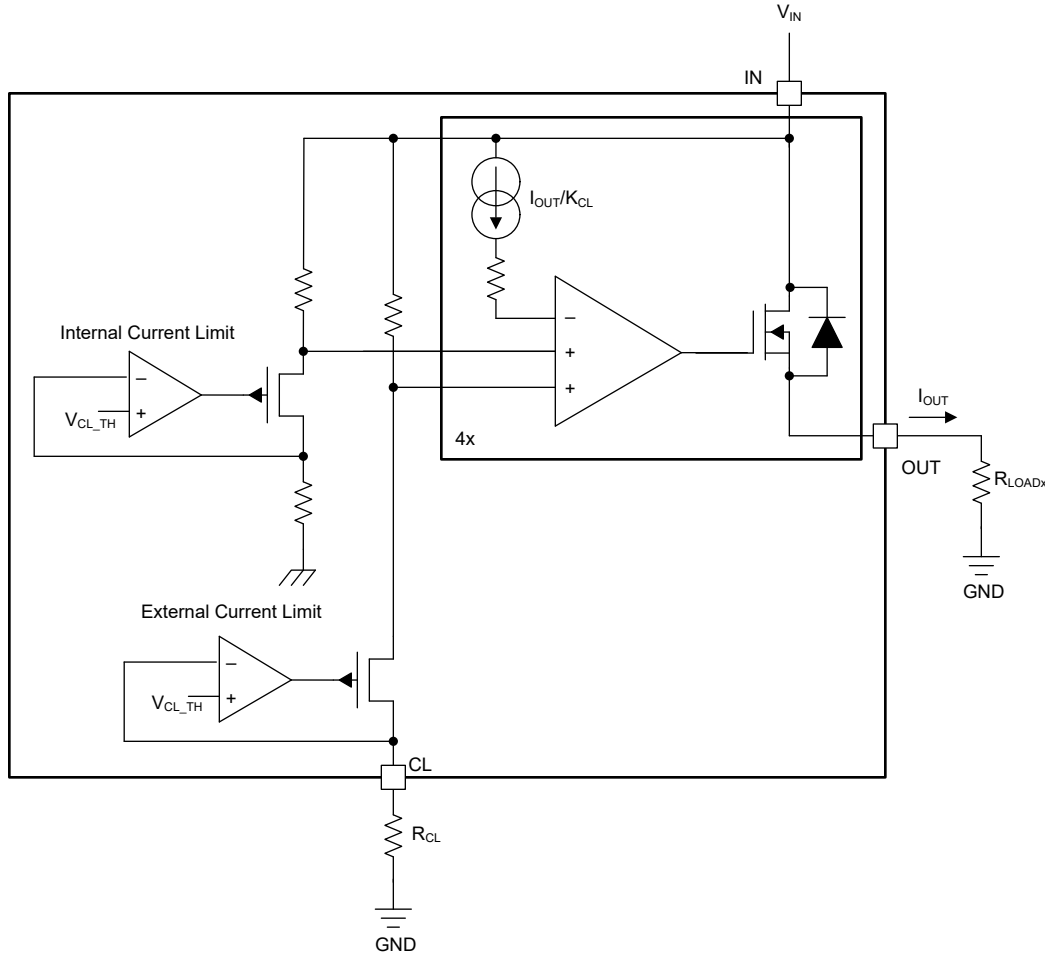
When switching an inductive load off, the inductive reactance tends to pull the output voltage negative. Excessive negative voltage could cause the power FET to break down. To protect the power FET, an internal clamp between drain and source is internally implemented, namely V_{DS_CLAMP} .

$$V_{DS_CLAMP} = V_{IN} - V_{OUTx} \tag{7}$$

During the period of demagnetization (t_{decay}), the power FET is turned on for inductance-energy dissipation. The total energy is dissipated in the high-side switch (E_{HSS}). Total energy includes the energy of the power supply (E_{IN}) and the energy of the load (E_{LOAD}). If resistance is in series with inductance, some of the load energy is dissipated on the resistance (E_R) and the inductor itself (E_L).

$$E_{HSS} = E_{IN} + E_{LOAD} = E_{IN} + E_L + E_R \tag{8}$$

When an inductive load switches off, E_{HSS} causes high thermal stressing on the device. The upper limit of the power dissipation depends on the device intrinsic capacity, ambient temperature, and board dissipation condition.



图 8-5. Drain-to-Source Clamping Structure



图 8-6. Inductive Load Switching-Off Diagram

From the perspective of the high-side switch, E_{HSS} equals the integration value during the demagnetization period.

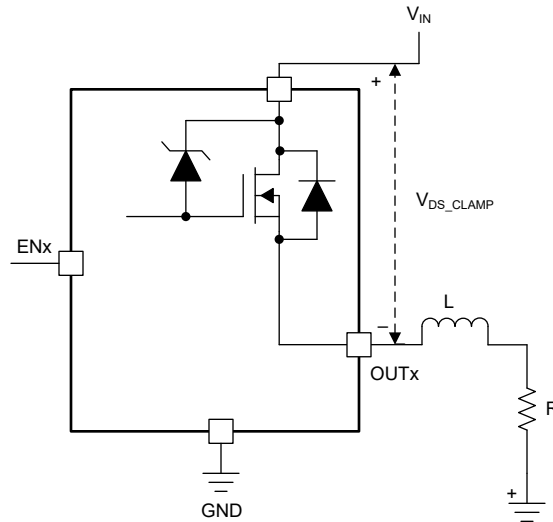
$$E_{HSSx} = \int_0^{t_{DECAYx}} V_{DS_CLAMP} \times I_{OUTx}(t) dt \quad (9)$$

$$t_{DECAYx} = \frac{L}{R} \times \ln\left(\frac{R \times I_{OUT(MAX)} + |V_{OUT}|}{|V_{OUT}|}\right) \quad (10)$$

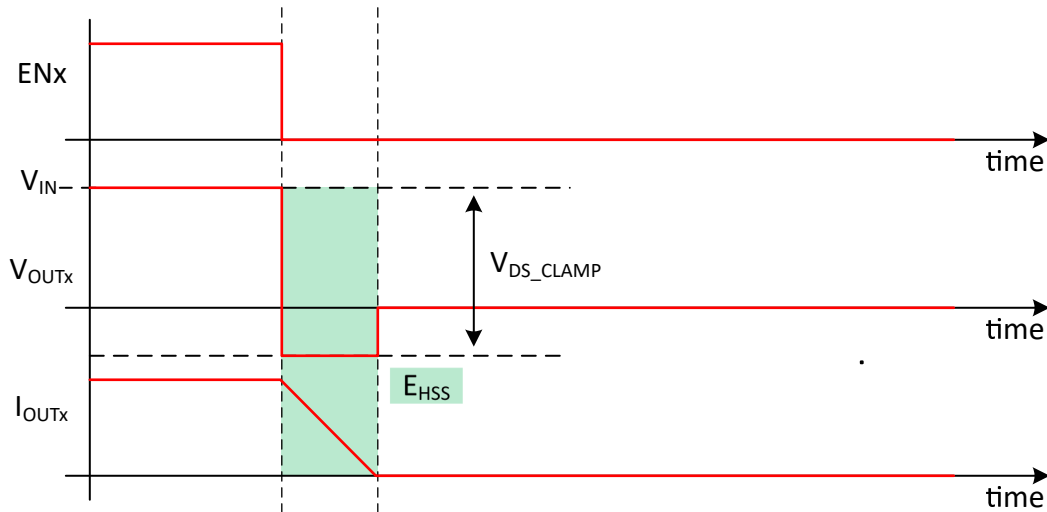
$$E_{HSSx} = L \times \frac{V_{IN} + |V_{OUT}|}{R^2} \times \left\{ (R \times I_{OUT(MAX)}) - \left[|V_{OUT}| \times \ln\left(\frac{R \times I_{OUT(MAX)} + |V_{OUT}|}{|V_{OUT}|}\right) \right] \right\} \quad (11)$$

When R approximately equals 0, E_{HSS} can be given simply as:

$$E_{HSSx} = \frac{1}{2} \times L \times I_{OUT(MAX)}^2 \times \left[\frac{(V_{IN} + |V_{OUT}|)}{|V_{OUT}|} \right] \tag{12}$$

图 8-7 是设备驱动电感负载并在 NMOS 过流元件（跨 IN 和 OUT1）期间耗散 40 mJ 能量的电感性回电波形。该能量是通过在 2.8（在 I_{OUT1}）时关闭通道 # 1 进行控制的。

显示的信号定义如 [Scope Signals Description](#) 所示。

表 8-1. Scope Signals Description

Channel #	Name of the Signal	Signal Color
1	V _{EN1}	Blue
2	V _{IN}	Red
3	V _{OUT1}	Green
4	I _{OUT1}	Magenta
Math	E _{HSS1}	Cyan

该设备还优化了钳位激活时的关断速度。此优化可以帮助系统设计，将瞬态功率和 EMI 的影响降至最低。



图 8-7. Inductive Load Switching-Off Waveform of 40mJ

A. The nominal inductor value use for this waveform is 8mH.

Note that for PWM-controlled inductive loads, it is recommended to add the external freewheeling circuitry shown in 图 8-8 to protect the device from repetitive power stressing. TVS is used to achieve the fast decay. See 图 8-8 for more details.

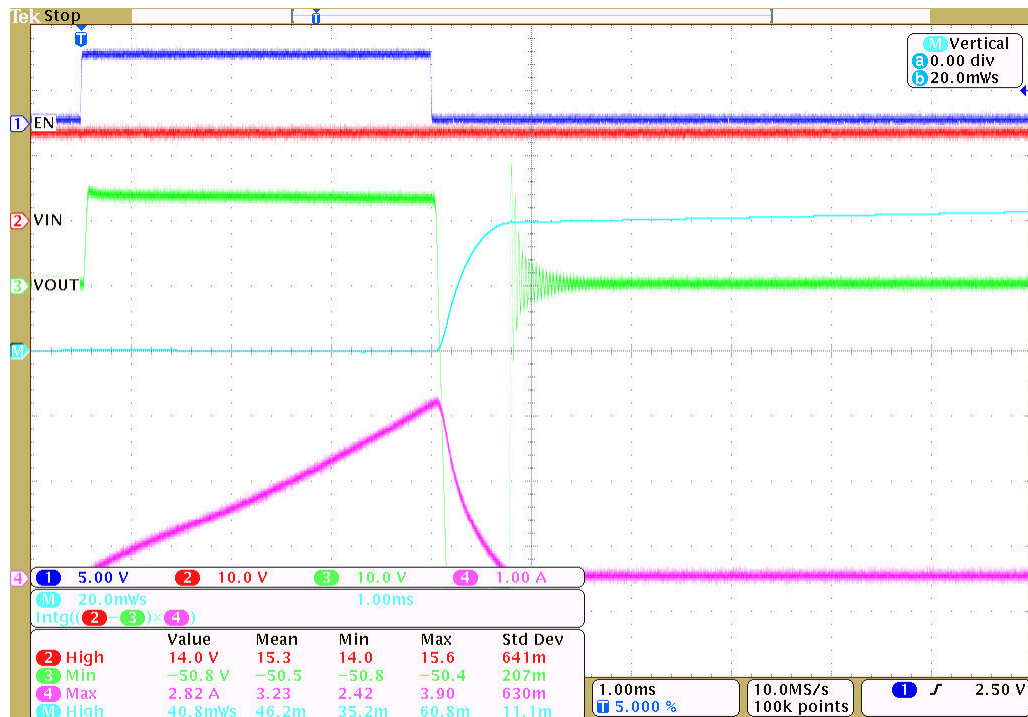

图 8-8. Protection With External Circuitry

8.3.5 Fault Detection and Reporting

8.3.5.1 Diagnostic Enable Function

The DIAG_EN pin enables or disables the diagnostic functions. If multiple devices are used, but the ADC resource is limited in the house-keeping microcontroller, the MCU can use GPIOs to set DIAG_EN high to enable the diagnostics of one device while disabling the diagnostics of the other devices by setting DIAG_EN low. In addition, the device can keep the power consumption to a minimum by setting DIAG_EN and ENx low.

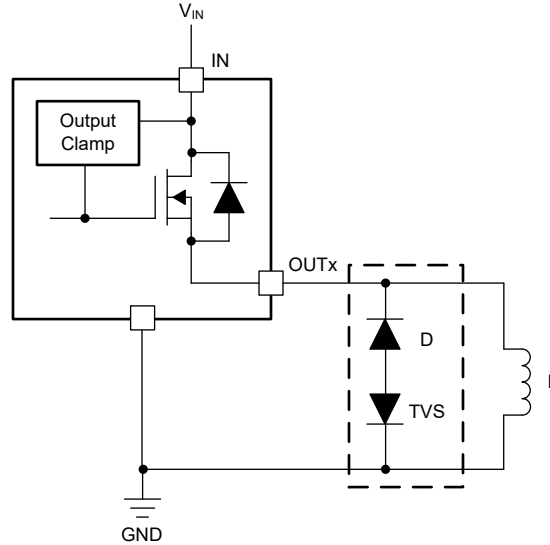
8.3.5.2 Multiplexing of Current Sense

SEL and SEH are the multiplexer selector high and low digital inputs. The multiplexer controls the channel selection for the current-sense function. As this function is shared among all four channels, only one at a time can be observed. See 表 8-2 for more details.

表 8-2. Diagnosis Configuration Table

DIAG_EN ⁽¹⁾	ENx ⁽¹⁾	SEH ⁽¹⁾	SEL ⁽¹⁾	CS ACTIVATED CHANNEL	CS, FAULT	PROTECTIONS AND DIAGNOSTICS
L	H	—	—	—	High impedance	Diagnostics disabled, full protection
	L					Diagnostics disabled, no protection
H	—	0	0	Channel # 1	See 表 8-3	See 表 8-3
		0	1	Channel # 2		
		1	0	Channel # 3		
		1	1	Channel # 4		

(1) L = 0 = logical zero (false), H = 1 = logical one (true), — = don't care

8.3.5.3 Fault Table

表 8-3 applies when the DIAG_EN pin is enabled.

表 8-3. Fault Table

CONDITIONS	ENx ⁽²⁾	OUTx ⁽²⁾	THER ⁽²⁾	CRITERION ⁽²⁾	CS	FAULT	FAULT RECOVERY
Normal	L	L	—	—	0	H	—
	H	H	—	—	In linear region	H	—
Overload, short to ground	H	L	—	Current limit triggered	V _{CS_FAULT}	L	Auto

表 8-3. Fault Table (续)

CONDITIONS	ENx ⁽²⁾	OUTx ⁽²⁾	THER ⁽²⁾	CRITERION ⁽²⁾	CS	FAULT	FAULT RECOVERY
Open load ⁽¹⁾ , short to power, reverse polarity	L	H	—	$V_{IN} - V_{OUTx} < V_{OL_OFF}$	V _{CS_FAULT}	L	Auto
Thermal shutdown	H	—	L	T _{SD} triggered	V _{CS_FAULT}	L	Output auto-retry. Fault recovers when T _J < T _(SD,rst) or when INx toggles.
			H				Output latch off. Fault recovers when INx toggles.
Thermal swing	H	—	—	T _{SW} triggered	V _{CS_FAULT}	L	Auto

(1) An external pullup is required for open-load detection.

(2) L = logical zero (false), H = logical one (true), — = don't care

8.3.5.4 FAULT Reporting

A global $\overline{\text{FAULT}}$ pin is used to monitor the global fault condition among all the channels. When a fault condition occurs on any channel, the $\overline{\text{FAULT}}$ pin is pulled down to GND. A 3.3-V or 5-V external pullup is required to match the supply level of the house-keeping processor.

After the $\overline{\text{FAULT}}$ report, the processor can check and identify the channel in fault status by using the multiplexed current sensing pin. The CS pin also works as a fault report with an internal pullup voltage, V_{CS_FAULT}.

8.3.6 Full Diagnostics

8.3.6.1 Short-to-GND and Overload Detection

When a channel is on, a short to GND or overload condition causes overcurrent. If the overcurrent triggers either the internal or external current-limit threshold, the fault condition is reported out. The microcontroller can handle the overcurrent by turning off the switch. The device heats up if no actions are taken. If a thermal shutdown occurs, the current limit is I_{CL_TSD} (70% of the externally set current limit) or I_{CL_INTERNAL_TSD} (6.5 A when using the internal current limit) to keep the power stressing on the power FET to a minimum. The device automatically recovers when the fault condition is removed.

8.3.6.2 Open-Load Detection

8.3.6.2.1 Channel On

When a channel is on (ENx = High), benefiting from the high-accuracy current sense in a small current range, if an open-load event occurs, it can be detected as an ultra-low V_{CS} and handled by the microcontroller. Note that the detection is not reported on the $\overline{\text{FAULT}}$ pin. The microcontroller must multiplex the SEL and SEH pins to detect the channel-on open-load fault proactively.

8.3.6.2.2 Channel Off

When a channel is off, if a load is connected, the output is pulled down to GND. But if an open load occurs, the output voltage is close to the supply voltage ($V_{IN} - V_{OUTx} < V_{OL_OFF}$), and the fault is reported out. V_{OL_OFF} is between 1.6 and 2.6 V.

There is always a leakage current I_F (maximum of 0.5 μA at 25°C or 8 μA at 125°C), present on the output due to internal logic control path or external humidity, corrosion, and so forth. Thus, TI recommends an external pullup resistor to offset the leakage current when an open load is detected. The recommended pullup resistance is 20 kΩ.



图 8-9. Open-Load Detection in Off-State

8.3.6.3 Short-to-Input Detection

Short-to-Input has the same detection mechanism and behavior as open-load detection, in both the on-state and off-state. See [表 8-3](#) for more details.

In the on-state, reverse current flows through the FET instead of the body diode, leading to less power dissipation. Thus, the worst case occurs in the off-state.

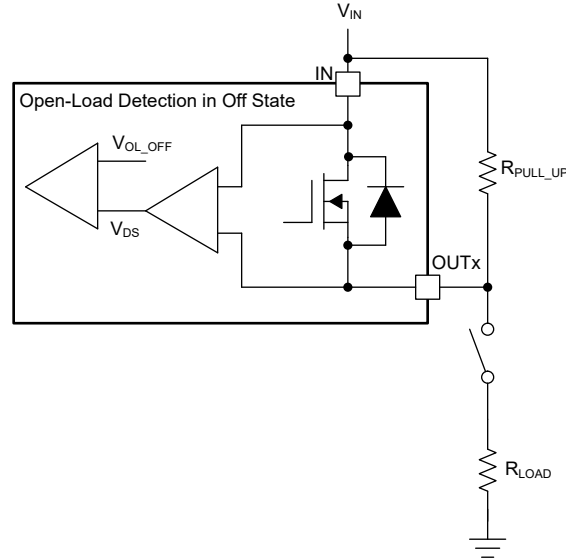
- If $V_{OUTX} - V_{IN} < V_F$ (body diode forward voltage), no reverse current occurs.
- If $V_{OUTX} - V_{IN} > V_F$, reverse current occurs. The current must be limited to less than I_{R1} . Setting an ENx pin high can minimize the power stress on its channel. Also, for external reverse protection, see [Reverse-Current Protection](#) for more details.

8.3.6.4 Reverse Polarity Detection

Reverse polarity detection has the same detection mechanism and behavior as open-load detection both in the on-state and off-state. See [表 8-3](#) for more details.

In the on-state, the reverse current flows through the FET instead of the body diode, leading to less power dissipation. Thus, the worst case occurs in the off-state. The reverse current must be limited to less than I_{R2} . Set the related ENx pin high to keep the power dissipation to a minimum. For external reverse-blocking circuitry, see [Reverse-Current Protection](#) for more details.

8.3.6.5 Thermal Fault Detection

To protect the device in severe power stressing cases, the device implements two types of thermal fault detection, absolute temperature protection (thermal shutdown) and dynamic temperature protection (thermal swing). Respective temperature sensors are integrated close to each power FET, so the thermal fault is reported by each channel. This arrangement can help the device keep the cross-channel effect to a minimum when some channels are in a thermal fault condition.

8.3.6.5.1 Thermal Shutdown

Thermal shutdown is active when the absolute temperature $T_J > T_{SD}$. When thermal shutdown occurs, the respective output turns off. The THER pin is used to configure the behavior after the thermal shutdown occurs.

- When the **THER** pin is low, thermal shutdown operates in the auto-retry mode. The output automatically recovers when $T_J < T_{SD} - T_{HYS}$, but the current is limited to I_{CL_TSD} or $I_{CL_INTERNAL_TSD}$ (depending if the

internal or external current limit is used) to avoid repetitive thermal shutdown. The thermal shutdown fault signal is cleared when $T_J < T_{SD_RST}$ or after toggling the related ENx pin.

- When the **THER** pin is high, thermal shutdown operates in the latch mode. The output latches off when thermal shutdown occurs. When the THER pin goes from high to low, thermal shutdown changes to auto-retry mode. The thermal shutdown fault signal is cleared after toggling the related ENx pin.

Thermal swing activates when the power FET temperature is increasing sharply, that is, when $\Delta T = T_{FET} - T_{LOGIC} > T_{SW}$, then the output turns off. The output automatically recovers and the fault signal clears when $\Delta T = T_{FET} - T_{LOGIC} < T_{SW} - T_{HYS}$. Thermal swing function improves the device reliability when subjected to repetitive fast thermal variation. As shown in 图 8-10, multiple thermal swings are triggered before thermal shutdown occurs.



图 8-10. Thermal Behavior Diagram

8.3.7 Full Protections

8.3.7.1 UVLO Protection

The device monitors the supply voltage V_{IN} , to prevent unpredictable behaviors when V_{IN} is too low. When V_{IN} falls down to IN_{UVLOF} , the device shuts down. When V_{IN} rises up to IN_{UVLOR} , the device turns on.

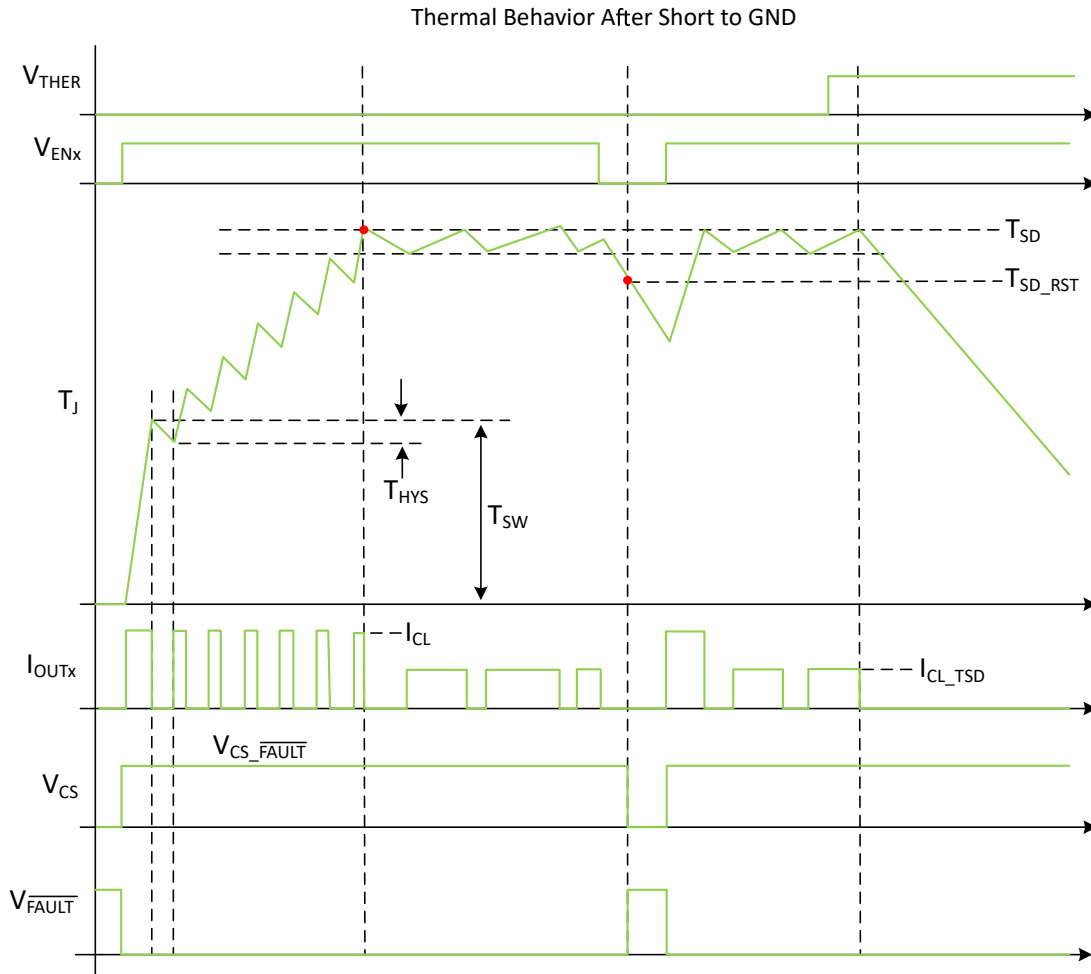
8.3.7.2 Loss-of-GND Protection

When loss of GND occurs, output is shut down regardless of whether the ENx pin is high or low. The device can protect against two ground-loss conditions, loss of device GND and loss of module GND.

8.3.7.3 Protection for Loss of Power Supply

When loss of supply occurs, the output is shut down regardless of whether the ENx pin is high or low. For a resistive or a capacitive load, loss of supply has no risk. But for a charged inductive load, the current is driven from all the I/O pins to maintain the inductance current. To protect the system in this condition, TI recommends two types of external protections: the GND network or the external free-wheeling diode.



图 8-11. Protection for Loss of Power Supply, Method 1



图 8-12. Protection for Loss of Power Supply, Method 2

8.3.7.4 Reverse-Current Protection

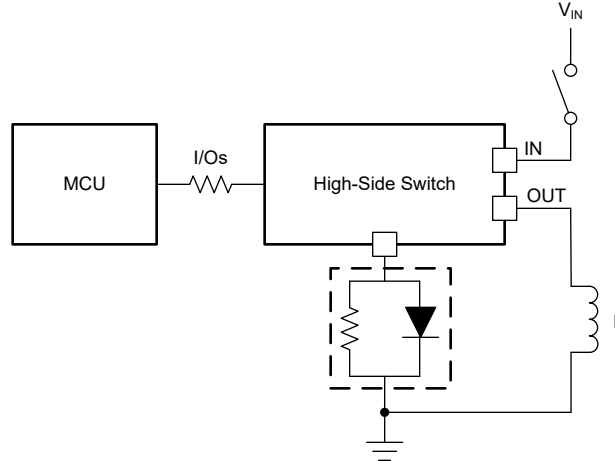
Reverse current occurs in two conditions: short to power and reverse polarity.

- When a short to the input occurs, there is only reverse current through the body diode. I_{R1} specifies the limit of the reverse current.
- In a reverse-polarity condition, there are reverse currents through the body diode and the device GND pin. I_{R2} specifies the limit of the reverse current. The GND pin maximum current is specified in the [Absolute Maximum Ratings](#).

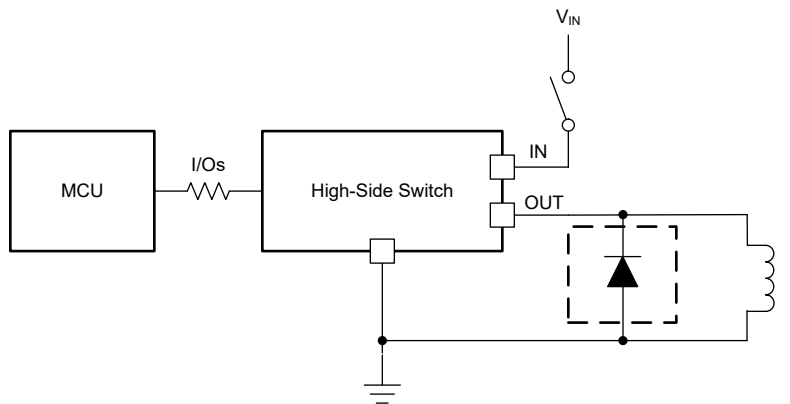
To protect the device, TI recommends two types of external circuitry.

- Adding a blocking diode. Both the IC and load are protected when in reverse polarity.



图 8-13. Reverse-Current External Protection, Method 1

- Adding a GND network. The reverse current through the device GND is blocked. The reverse current through the FET is limited by the load itself. TI recommends a resistor in parallel with the diode as a GND network. The recommended selection are 1-kΩ resistor in parallel with a >100-mA diode. If multiple high-side switches are used, the resistor and diode can be shared among devices. The reverse current protection diode in the GND network forward voltage should be less than 0.6 V in any circumstances. In addition a minimum resistance of 4.7 kΩ is recommended on the I/O pins.

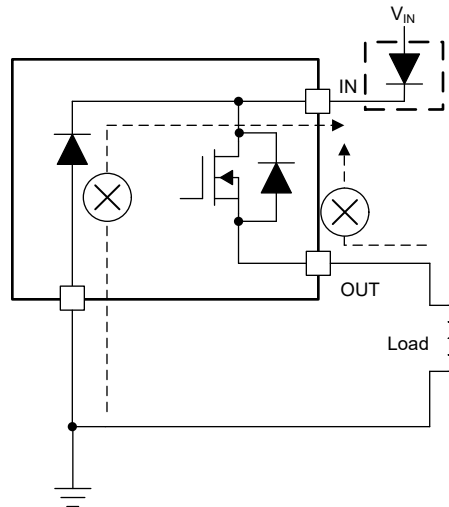

图 8-14. Reverse-Current External Protection, Method 2

8.3.7.5 MCU I/O Protection

In some severe systems conditions the loss of power with inductive loads, results on a negative pulse on the GND pin. This pulse can cause damage on the connected microcontroller. TI recommends serial resistors to protect the microcontroller, for example, 4.7 kΩ when using a 3.3-V microcontroller and 10 kΩ for a 5-V microcontroller.

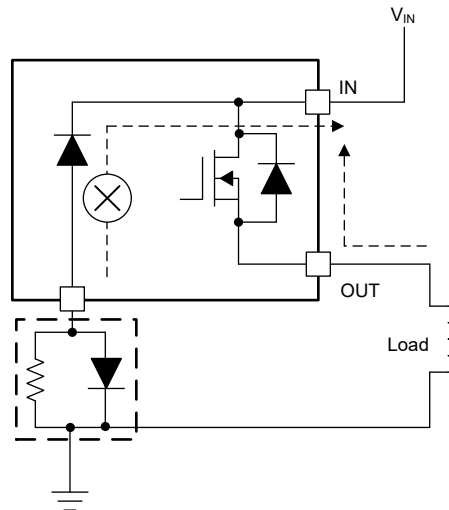

图 8-15. MCU I/O External Protection

8.3.8 Parallel Operation

The TPS7H2140-SEP can be configured in parallel operation either to increase the current capability, up to 5.4 A, or to reduce the R_{ON} (on-state resistance). Any channels combination can be parallel by connecting the desired channels outputs (OUT_x) and enable (EN_x) signals together. 图 8-16 shows the input/output connections when paralleling all 4 channels of the TPS7H2140-SEP

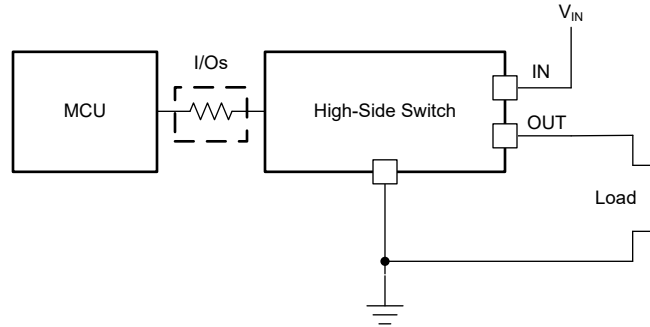

图 8-16. Input and Output Connections when paralleling all channels in the TPS7H2140-SEP

For proper device operation follow the following recommendations:

1. Connect the EN_x inputs signals of the channels to be parallel together and as close to the device (I.C.) as possible.
2. Connect the OUT_x output signals of the channels to be parallel together and as close to the device (I.C.) as possible.
3. Take in consideration the deviations (or errors) in the R_{ON} , current limit and voltage clamp for the system design.

Due to imbalance of currents in each channel (due to ΔR_{ON}) the total load current is not equally distributed. The channel current bounds are:

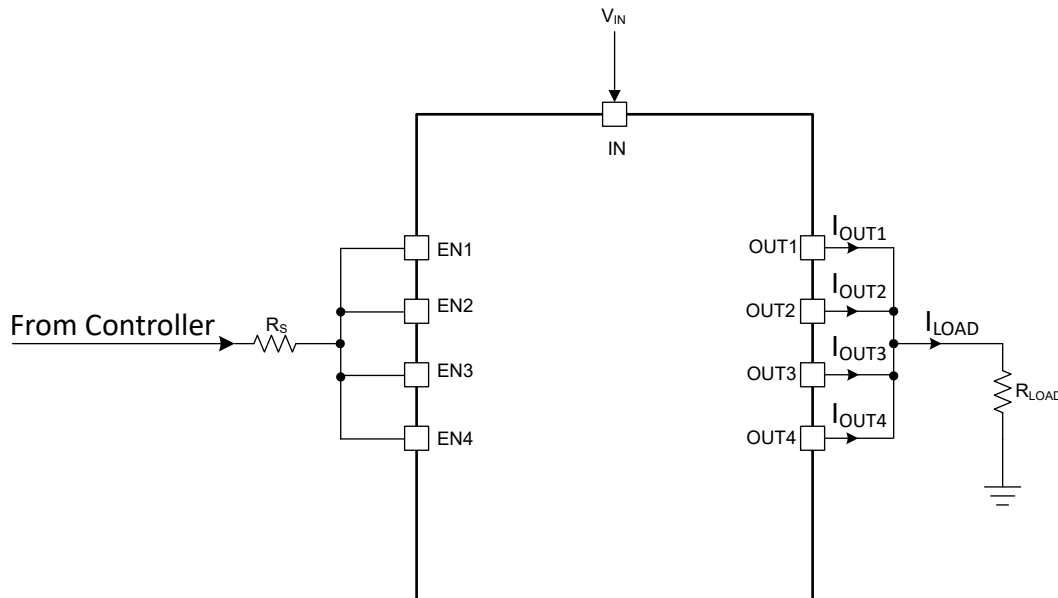
$$\bullet \quad I_n(\max) = \frac{I_{LOAD}}{N} \times \left(\frac{1 + \Delta R_{ON}}{1 - \Delta R_{ON}} \right) \quad (13)$$

$$I_n(\min) = \frac{I_{LOAD}}{N} \times \left(\frac{1 - \Delta R_{ON}}{1 + \Delta R_{ON}} \right) \quad (14)$$

where N is equal to the # of parallel channels and ΔR_{ON} is the difference between the on-state resistance for any given channel.

At 25 °C the ΔR_{ON} maximum value is specified at 6 % (or 0.06), using this value and assuming the I_{LOAD} is 5 A the current by each channel can be calculated (using [方程式 13](#) and [方程式 14](#)) as:

$$1.11 \leq I_n \leq 1.41 \quad (15)$$

When paralleling channels is important to know that the current limit is programmed per channel based (or the same for all channels). The sensed current ratio on the current limit circuit have variations (as specified by dK_{CL}/K_{CL}). To deliver the expected load before reaching the current limit the designer must account for variation on the sensed current gain and variations on the channels currents due to on-resistance mismatch as described before. To select the current limit resistor when accounting for all system errors (ΔR_{ON} and dK_{CL}/K_{CL}) use:

$$R_{CL}(\max) = \frac{V_{CL_TH} \times K_{CL} \left(1 - \left| \frac{dK_{CL}}{K_{CL}} \right| \right)}{I_n(\max)} \quad (16)$$

As the sensed current is measured in a per channel based and reported on the CS pin. To measure the total load current of parallel channels, the individual current must be measured and added together. The individual currents are measured by using the SEH and SEL (mux inputs) in conjunction with the CS voltage.

The diagnostics as specified by [Fault Table](#) are globally reported, as the fault conditions affects all channels simultaneously. When using the internal clamp (V_{DS_CLAMP}) to dissipate the inductive kick-back energy the energy must be limited to the maximum of a single channel.

备注

The energy does not scale with the number of parallel channels and must be limited to the absolute maximum value of 40mJ.

8.4 Device Functional Modes

8.4.1 Working Modes

The device has three working modes: normal mode, standby mode, and standby mode with diagnostics.

Note that ENx must be low for $t > t_{LOW_OFF}$ to enter the standby mode, where t_{LOW_OFF} is the standby mode deglitch time used to avoid false triggering. [图 8-17](#) shows a working-mode diagram.



图 8-17. Working Modes

9 Application and Implementation

备注

Information in the following applications sections is not part of the TI component specification, and TI does not warrant its accuracy or completeness. TI's customers are responsible for determining suitability of components for their purposes, as well as validating and testing their design implementation to confirm system functionality.

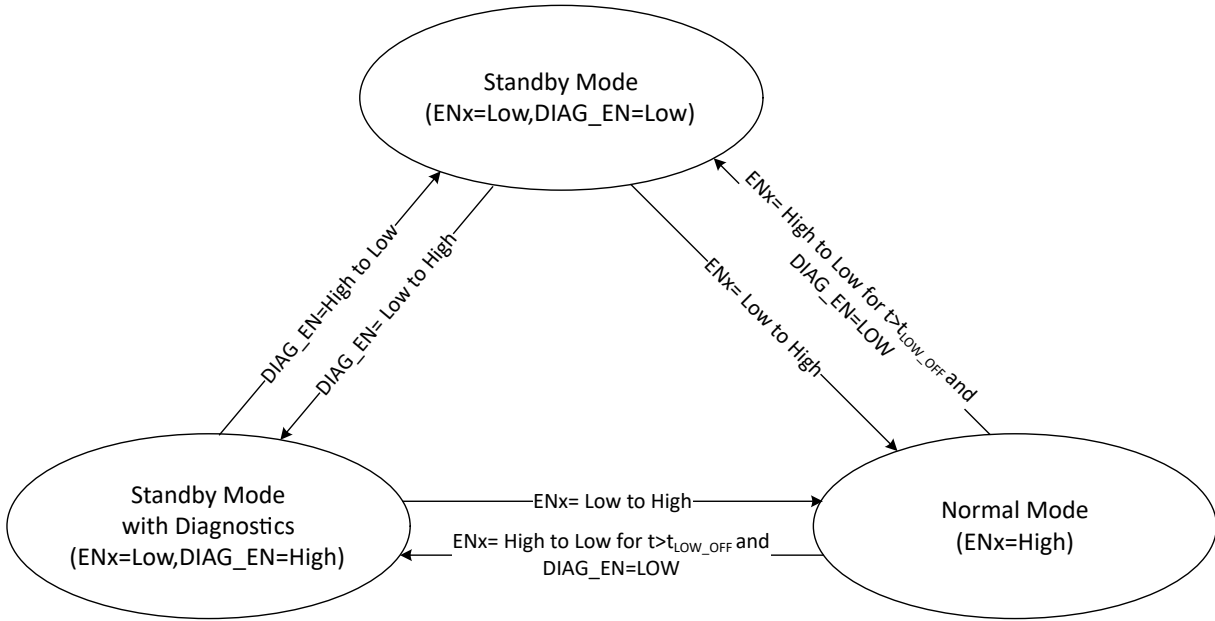
9.1 Application Information

The TPS7H2140-SEP device is capable of driving a wide variety of resistive, inductive, and capacitive loads, including: relays, solenoids, heaters, and sub-modules. Full diagnostics and high-accuracy current-sense features enable intelligent control of the load. An external adjustable current limit improves the reliability of the whole system by clamping the inrush or overload current.

9.2 Typical Application



图 9-1. Typical Application Diagram

9.2.1 Design Requirements

- $V_{IN} = 12\text{ V}$
- Maximum load current up to 1 A (nominal) and for each channel
- Up to 1.1 A during transients before the current is limited.
- Current sense for fault monitoring
- Expected current-limit value of 1.1 A
- Automatic recovery mode when thermal shutdown occurs
- Full diagnostics with 5-V MCU/FPGA

- Reverse-voltage protection with a blocking diode in the power-supply line

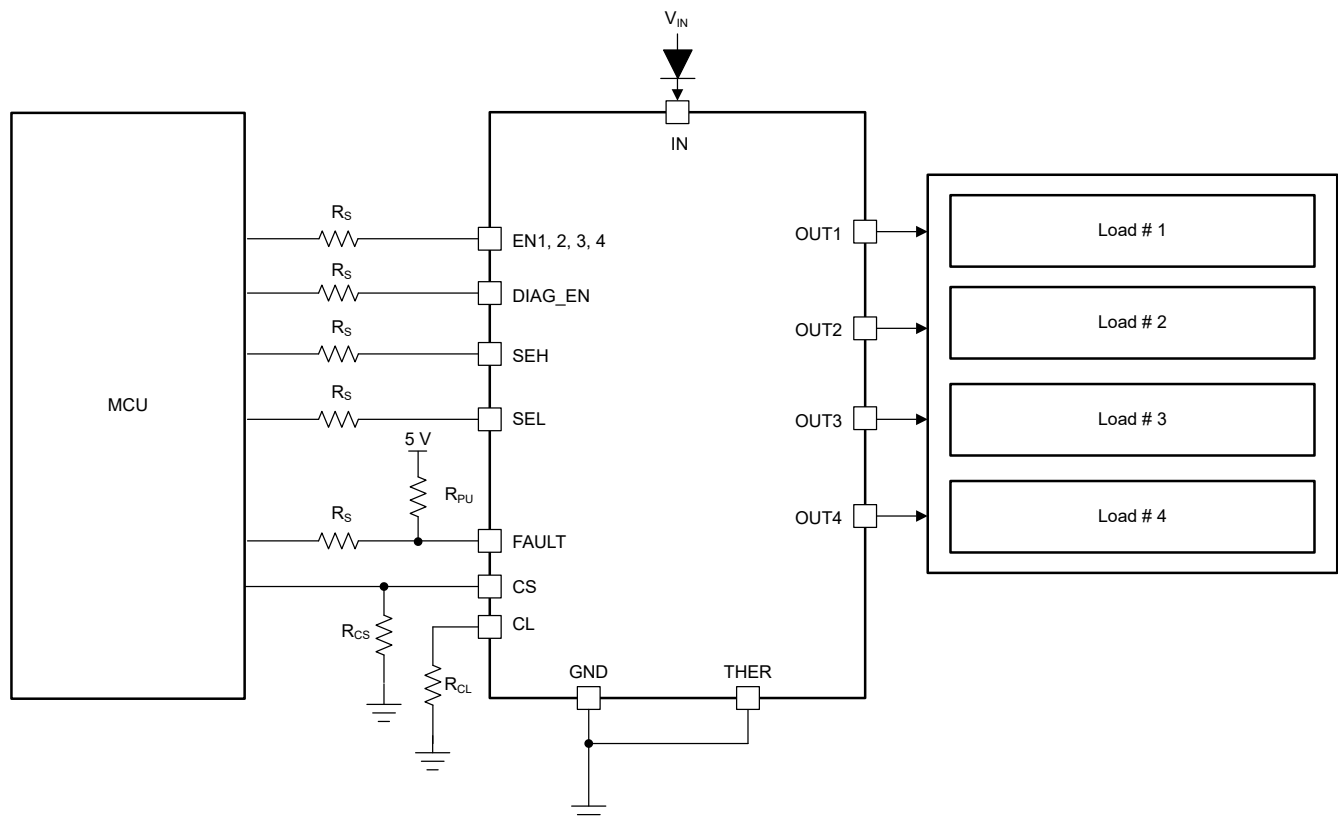
9.2.2 Detailed Design Procedure

When selecting the current limit resistor we most account for the accuracy of the limit. The accuracy on the range of the desired current limit is $\pm 20\%$.

As the current limit can be shifted up to -20% , is desired to boost the load current by this factor. In which case the load current for the calculation of the current limit is: 1.375 A.

To keep the 1.1 A nominal current in the 0 to 4 V current-sense range, calculate the R_{CS} resistor using 方程式 17. To achieve better current-sense accuracy, a 1% tolerance or better resistor is preferred.

$$R_{CS} = \frac{V_{CS}}{I_{CS}} = \frac{V_{CS} \times K_{CS}}{I_{OUTx}} = \frac{4 \times 300}{1.1} = 1.09 \text{ k}\Omega \quad (17)$$

To set the adjustable current limit value at 2.5 A, calculate R_{CL} using 方程式 18.

$$R_{CL} = \frac{V_{CL_TH} \times K_{CL}}{I_{OUTx}} = \frac{0.8 \times 2500}{1.375} = 1.45 \text{ k}\Omega \quad (18)$$

TI recommends $R_S = 10 \text{ k}\Omega$ for 5-V MCU, and $R_{PU} = 10 \text{ k}\Omega$ as the pullup resistor.

9.2.3 Application Curves

图 9-2 shows a test example of soft-start when driving a big capacitive load. 图 9-3 shows an expanded waveform of the output current.



图 9-4 shows a test example of PWM-mode driving. 图 9-5 shows the expanded waveform of the rising edge. 图 9-6 shows the expanded waveform of the falling edge.



9.3 Power Supply Recommendations

The TPS7H2140-SEP is designed to operate from an input range between 4.5 V to 32 V. This supply voltage must be well regulated and proper local bypass capacitors should be used for proper electrical performance from V_{IN} to GND. Due to stringent requirements for space applications, typically numerous input bypass capacitors are used and the total capacitance is much larger than for commercial applications. The TPS7H2140-SEP evaluation module uses one 33- μF tantalum capacitor in parallel with one 10- μF , one 1- μF , and one 0.1- μF ceramic capacitor.

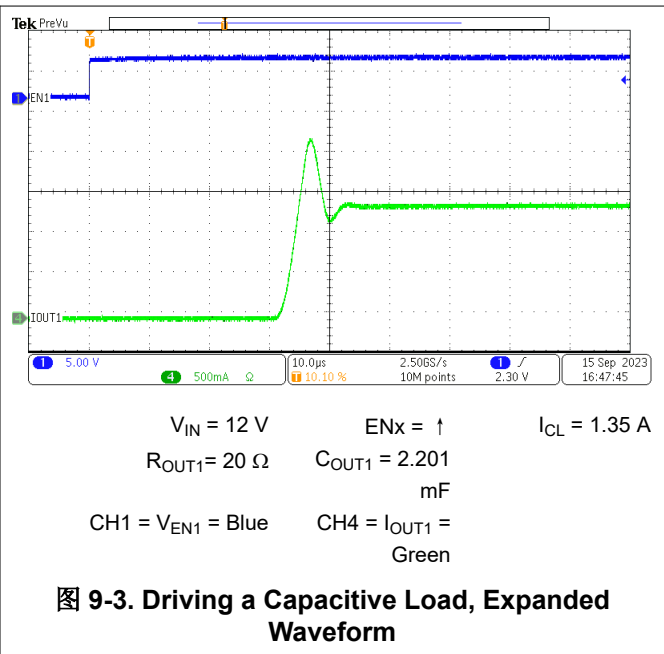
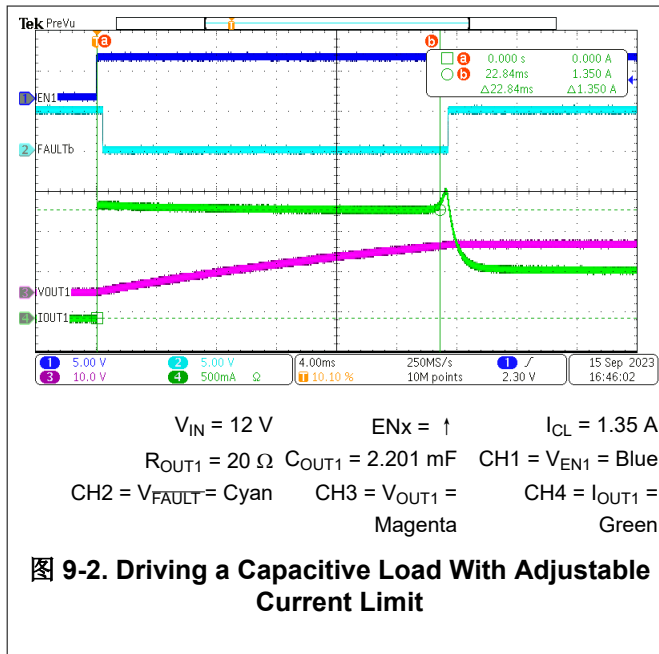
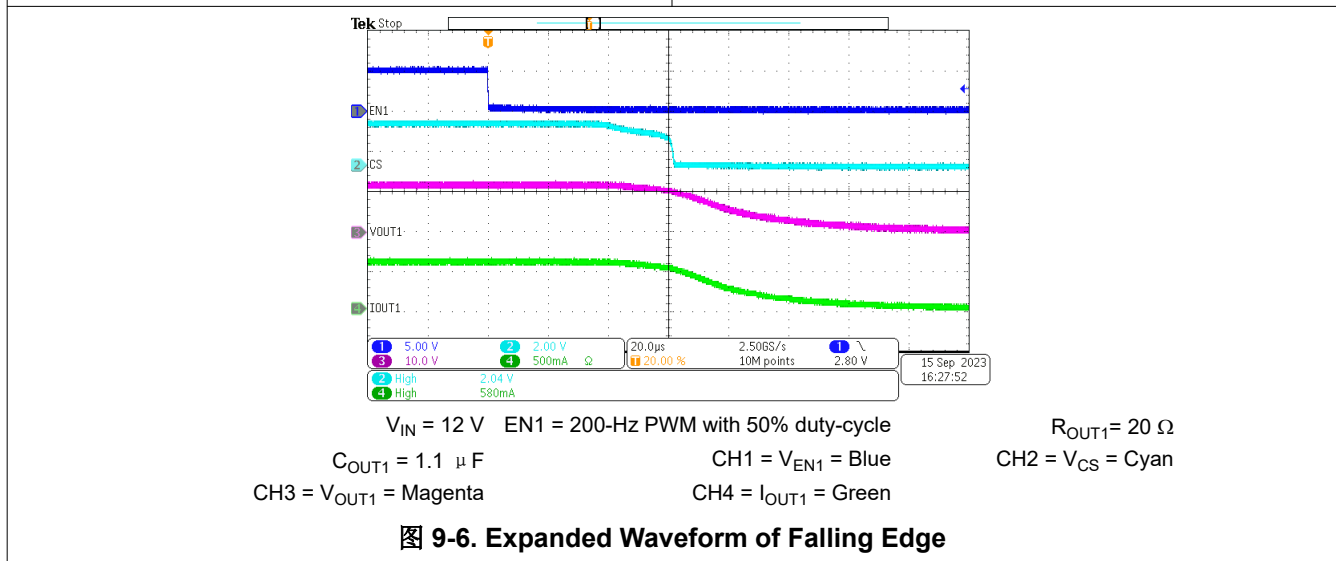
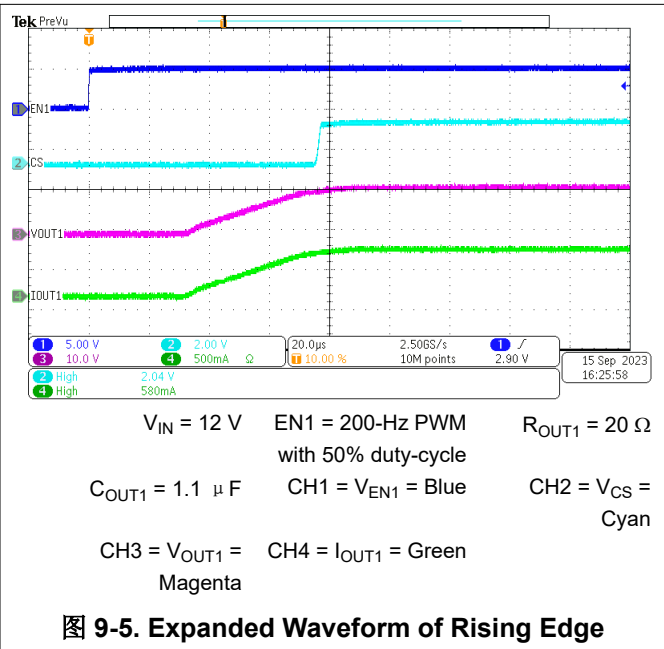
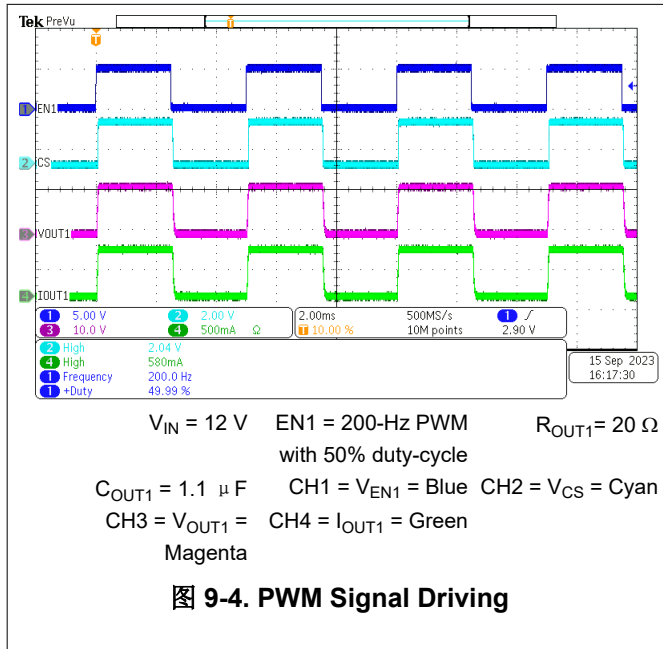
9.4 Layout

9.4.1 Layout Guidelines

To prevent thermal shutdown, T_J must be less than 150°C . The HTSSOP package has good thermal impedance. However, the PCB layout is very important. Good PCB design can optimize heat transfer, which is absolutely essential for the long-term reliability of the device.

- Maximize the copper coverage on the PCB to increase the thermal conductivity of the board. Maximum copper is extremely important when there are not any heat sinks attached to the PCB on the other side of the package.
- Add as many thermal vias as possible directly under the package ground pad to optimize the thermal conductivity of the board.
- All thermal vias should either be plated shut or plugged and capped on both sides of the board to prevent solder voids. To ensure reliability and performance, it is recommended a solder coverage greater than 85%.

9.4.2 Layout Examples

9.4.2.1 Without a GND Network

Without a GND network, tie the thermal pad directly to the board GND copper for better thermal performance.



图 9-7. Layout Example Without a GND Network

9.4.2.2 With a GND Network

With a GND network, tie the thermal pad as one trace to the board GND copper.

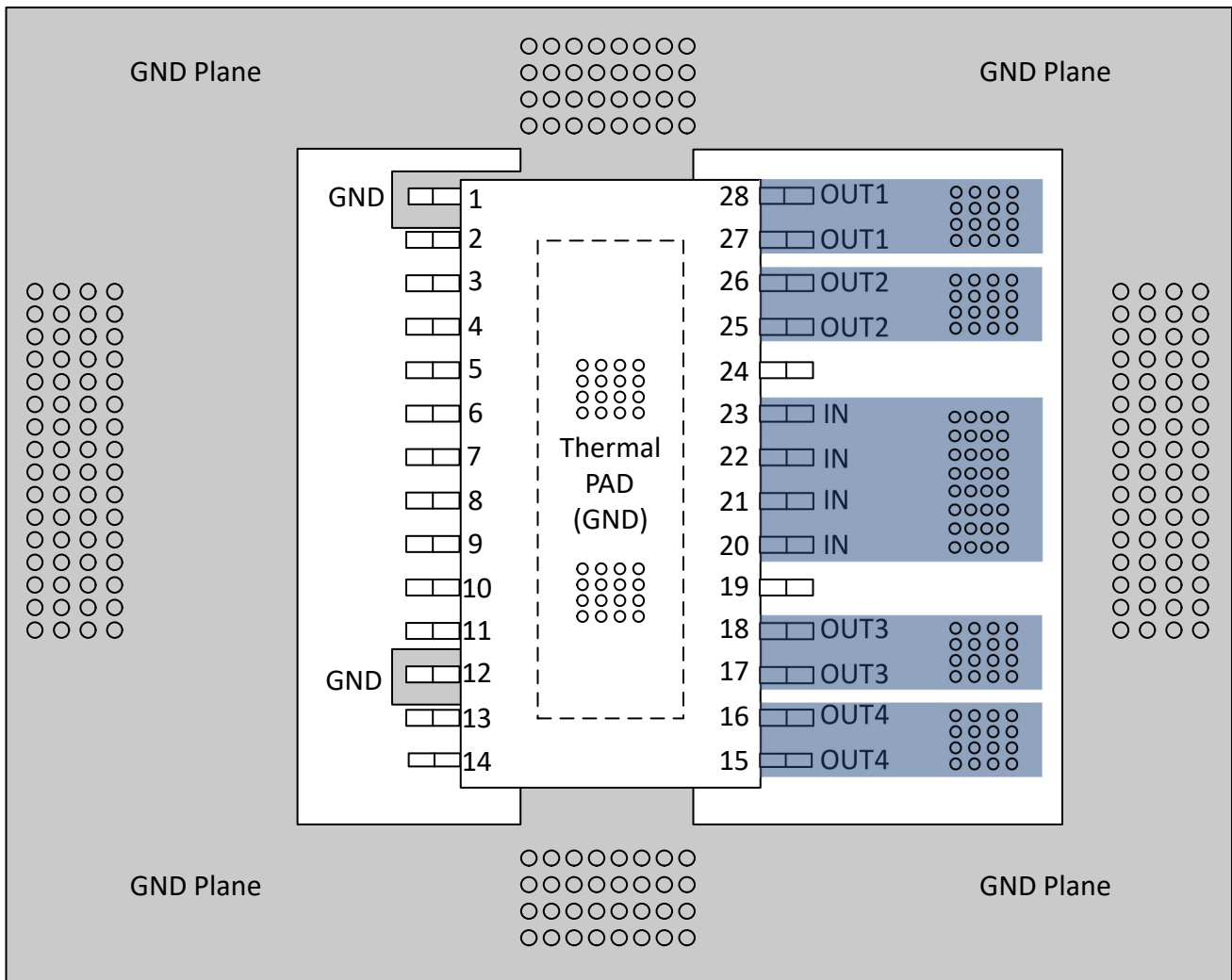

图 9-8. Layout Example With a GND Network

10 Device and Documentation Support

10.1 Documentation Support

10.1.1 Related Documentation

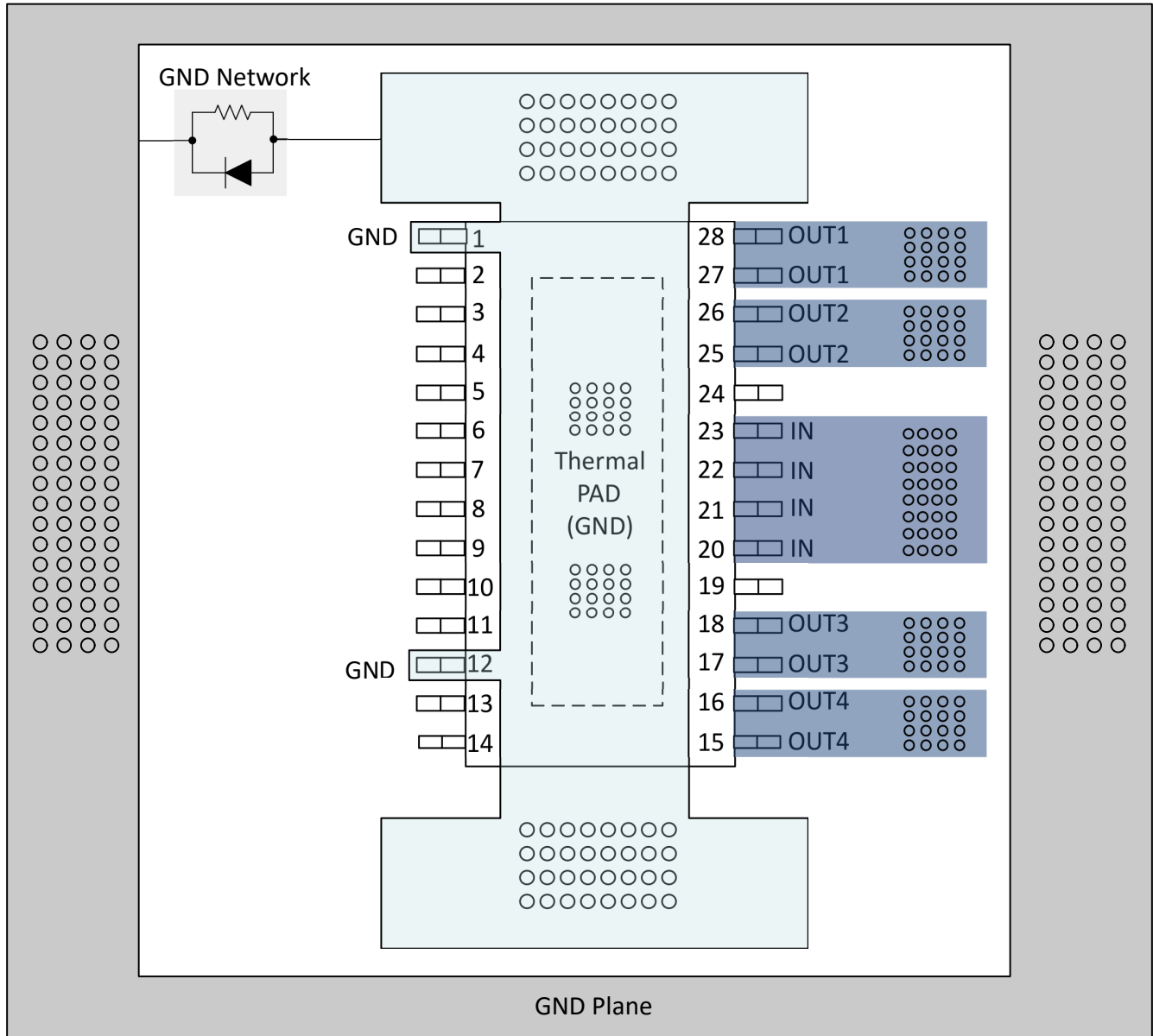
For related documentation see the following:

- Texas Instruments, [TPS7H2140-SEP Total Ionizing Dose \(TID\)](#)
- Texas Instruments, [Single-Event-Effects Test Report of the TPS7H2140-SEP Quad-channel eFuse](#)
- Texas Instruments, [TPS7H2140-SEP NDD Report](#)
- Texas Instruments, [TPS7H2140EVM Evaluation Module \(EVM\)](#)
- Texas Instruments, [Unencrypted PSpice Transient Model](#)
- Texas Instruments, [Load Switch Thermal Considerations](#)
- Texas Instruments, [Basics of eFuses](#)
- Texas Instruments, [Basics of Load Switches](#)
- Vendor Item Drawing, [V6223610](#)

10.2 接收文档更新通知

要接收文档更新通知，请导航至 [ti.com](#) 上的器件产品文件夹。点击 [订阅更新](#) 进行注册，即可每周接收产品信息更改摘要。有关更改的详细信息，请查看任何已修订文档中包含的修订历史记录。

10.3 支持资源

[TI E2E™ 中文支持论坛](#) 是工程师的重要参考资料，可直接从专家处获得快速、经过验证的解答和设计帮助。搜索现有解答或提出自己的问题，获得所需的快速设计帮助。

链接的内容由各个贡献者“按原样”提供。这些内容并不构成 TI 技术规范，并且不一定反映 TI 的观点；请参阅 TI 的 [使用条款](#)。

10.4 Trademarks

TI E2E™ is a trademark of Texas Instruments.

所有商标均为其各自所有者的财产。

10.5 静电放电警告



静电放电 (ESD) 会损坏这个集成电路。德州仪器 (TI) 建议通过适当的预防措施处理所有集成电路。如果不遵守正确的处理和安装程序，可能会损坏集成电路。

ESD 的损坏小至导致微小的性能降级，大至整个器件故障。精密的集成电路可能更容易受到损坏，这是因为非常细微的参数更改都可能会导致器件与其发布的规格不相符。

10.6 术语表

[TI 术语表](#) 本术语表列出并解释了术语、首字母缩略词和定义。

11 Mechanical, Packaging, and Orderable Information

The following pages include mechanical, packaging, and orderable information. This information is the most-current data available for the designated device. This data is subject to change without notice and without revision of this document. For browser-based versions of this data sheet, see the left-hand navigation pane.

PACKAGING INFORMATION

Orderable Device	Status (1)	Package Type	Package Drawing	Pins	Package Qty	Eco Plan (2)	Lead finish/ Ball material (6)	MSL Peak Temp (3)	Op Temp (°C)	Device Marking (4/5)	Samples
TPS7H2140MPWPTSEP	ACTIVE	HTSSOP	PWP	28	250	RoHS & Green	NIPDAU	Level-3-260C-168 HR	-55 to 125	7H2140PWP	Samples
V62/23610-01XE	ACTIVE	HTSSOP	PWP	28	250	RoHS & Green	NIPDAU	Level-3-260C-168 HR		7H2140PWP	Samples

(1) The marketing status values are defined as follows:

ACTIVE: Product device recommended for new designs.

LIFEBUY: TI has announced that the device will be discontinued, and a lifetime-buy period is in effect.

NRND: Not recommended for new designs. Device is in production to support existing customers, but TI does not recommend using this part in a new design.

PREVIEW: Device has been announced but is not in production. Samples may or may not be available.

OBsolete: TI has discontinued the production of the device.

(2) **RoHS:** TI defines "RoHS" to mean semiconductor products that are compliant with the current EU RoHS requirements for all 10 RoHS substances, including the requirement that RoHS substance do not exceed 0.1% by weight in homogeneous materials. Where designed to be soldered at high temperatures, "RoHS" products are suitable for use in specified lead-free processes. TI may reference these types of products as "Pb-Free".

RoHS Exempt: TI defines "RoHS Exempt" to mean products that contain lead but are compliant with EU RoHS pursuant to a specific EU RoHS exemption.

Green: TI defines "Green" to mean the content of Chlorine (Cl) and Bromine (Br) based flame retardants meet JS709B low halogen requirements of <=1000ppm threshold. Antimony trioxide based flame retardants must also meet the <=1000ppm threshold requirement.

(3) MSL, Peak Temp. - The Moisture Sensitivity Level rating according to the JEDEC industry standard classifications, and peak solder temperature.

(4) There may be additional marking, which relates to the logo, the lot trace code information, or the environmental category on the device.

(5) Multiple Device Markings will be inside parentheses. Only one Device Marking contained in parentheses and separated by a "~" will appear on a device. If a line is indented then it is a continuation of the previous line and the two combined represent the entire Device Marking for that device.

(6) Lead finish/Ball material - Orderable Devices may have multiple material finish options. Finish options are separated by a vertical ruled line. Lead finish/Ball material values may wrap to two lines if the finish value exceeds the maximum column width.

Important Information and Disclaimer:The information provided on this page represents TI's knowledge and belief as of the date that it is provided. TI bases its knowledge and belief on information provided by third parties, and makes no representation or warranty as to the accuracy of such information. Efforts are underway to better integrate information from third parties. TI has taken and continues to take reasonable steps to provide representative and accurate information but may not have conducted destructive testing or chemical analysis on incoming materials and chemicals. TI and TI suppliers consider certain information to be proprietary, and thus CAS numbers and other limited information may not be available for release.

In no event shall TI's liability arising out of such information exceed the total purchase price of the TI part(s) at issue in this document sold by TI to Customer on an annual basis.

GENERIC PACKAGE VIEW

PWP 28

PowerPAD™ TSSOP - 1.2 mm max height

4.4 x 9.7, 0.65 mm pitch

SMALL OUTLINE PACKAGE

This image is a representation of the package family, actual package may vary.
Refer to the product data sheet for package details.

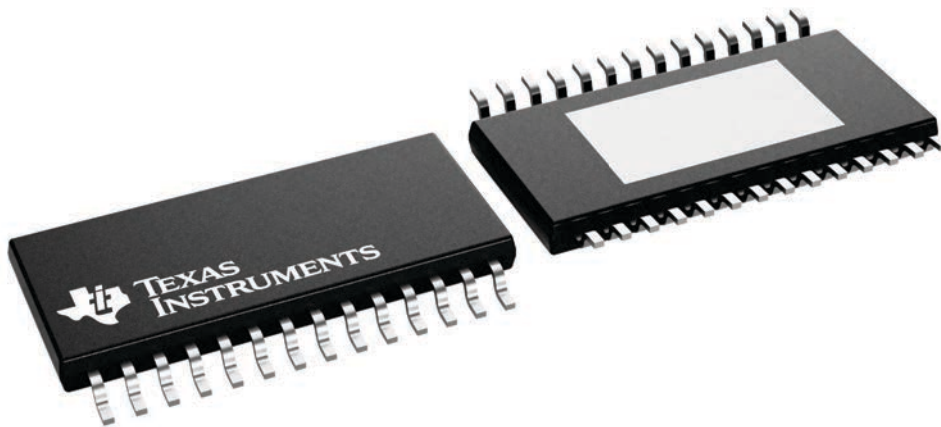

4224765/B

PWP0028M

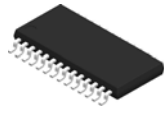

PACKAGE OUTLINE

PowerPAD™ TSSOP - 1.2 mm max height

SMALL OUTLINE PACKAGE

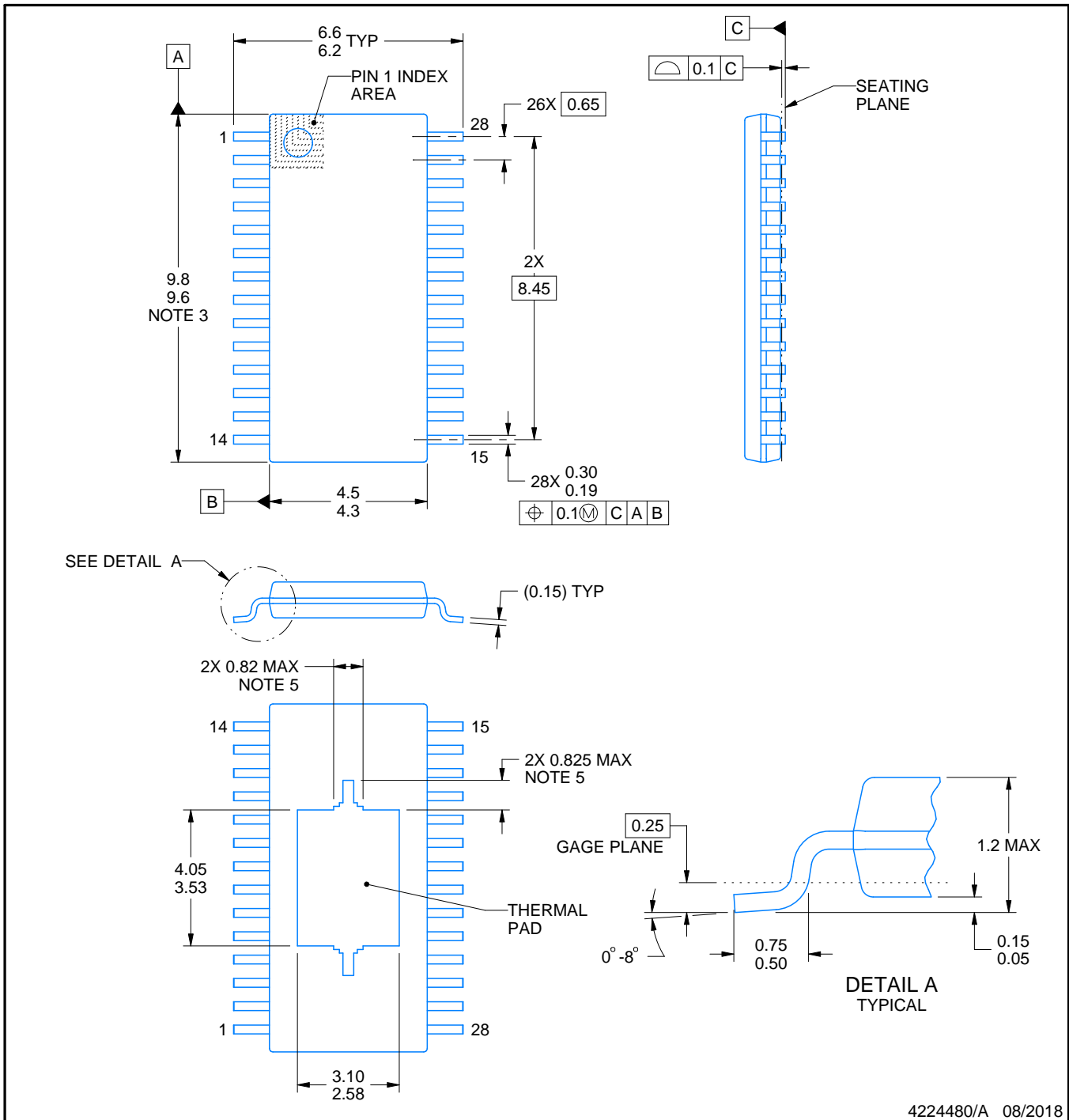

4224480/A 08/2018

NOTES:

PowerPAD is a trademark of Texas Instruments.

1. All linear dimensions are in millimeters. Any dimensions in parenthesis are for reference only. Dimensioning and tolerancing per ASME Y14.5M.
2. This drawing is subject to change without notice.
3. This dimension does not include mold flash, protrusions, or gate burrs. Mold flash, protrusions, or gate burrs shall not exceed 0.15 mm per side.
4. Reference JEDEC registration MO-153.
5. Features may differ or may not be present.

EXAMPLE BOARD LAYOUT

PWP0028M

PowerPAD™ TSSOP - 1.2 mm max height

SMALL OUTLINE PACKAGE

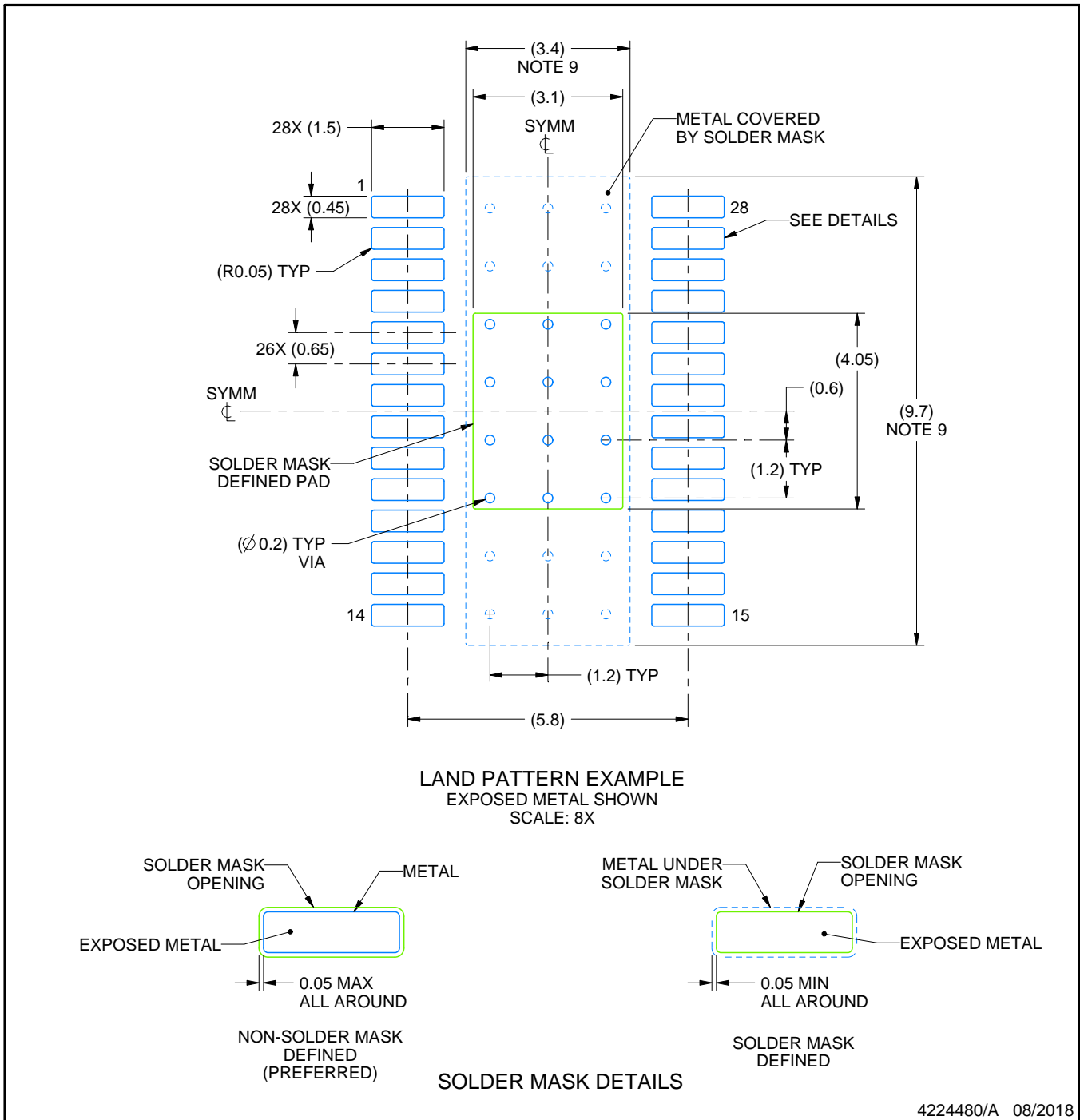

4224480/A 08/2018

NOTES: (continued)

6. Publication IPC-7351 may have alternate designs.
7. Solder mask tolerances between and around signal pads can vary based on board fabrication site.
8. This package is designed to be soldered to a thermal pad on the board. For more information, see Texas Instruments literature numbers SLMA002 (www.ti.com/lit/slma002) and SLMA004 (www.ti.com/lit/slma004).
9. Size of metal pad may vary due to creepage requirement.
10. Vias are optional depending on application, refer to device data sheet. It is recommended that vias under paste be filled, plugged or tented.

EXAMPLE STENCIL DESIGN

PWP0028M

PowerPAD™ TSSOP - 1.2 mm max height

SMALL OUTLINE PACKAGE

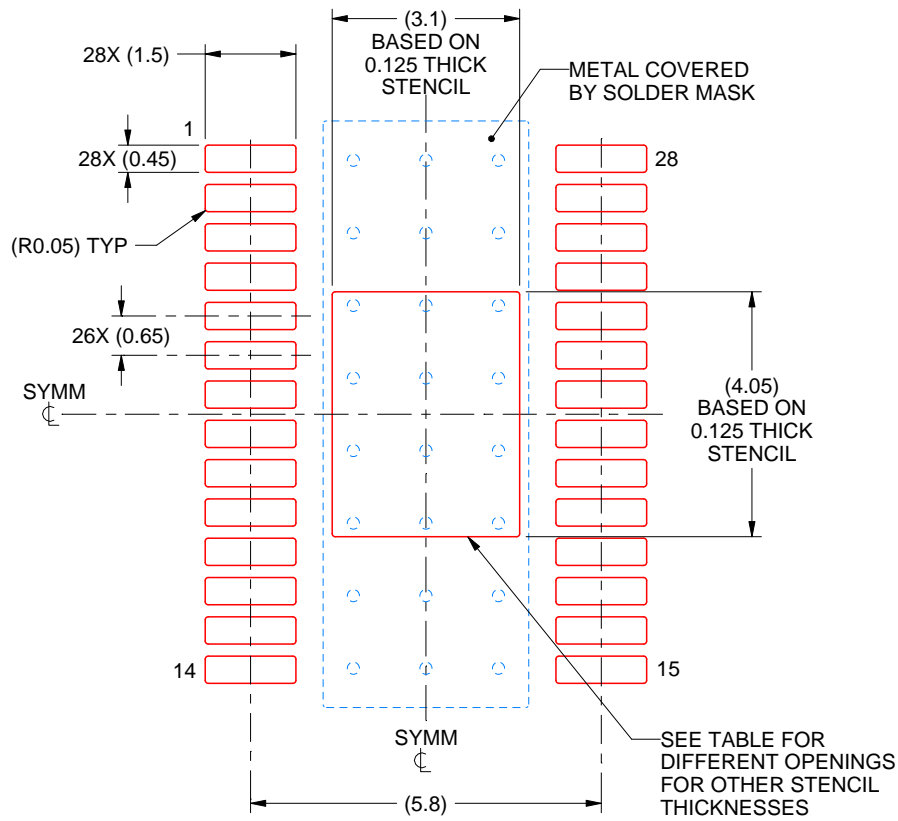

SOLDER PASTE EXAMPLE
 BASED ON 0.125 mm THICK STENCIL
 SCALE: 8X

STENCIL THICKNESS	SOLDER STENCIL OPENING
0.1	3.47 X 4.53
0.125	3.10 X 4.05 (SHOWN)
0.15	2.83 X 3.70
0.175	2.62 X 3.42

4224480/A 08/2018

NOTES: (continued)

11. Laser cutting apertures with trapezoidal walls and rounded corners may offer better paste release. IPC-7525 may have alternate design recommendations.
12. Board assembly site may have different recommendations for stencil design.

重要声明和免责声明

TI“按原样”提供技术和可靠性数据（包括数据表）、设计资源（包括参考设计）、应用或其他设计建议、网络工具、安全信息和其他资源，不保证没有瑕疵且不做任何明示或暗示的担保，包括但不限于对适销性、某特定用途方面的适用性或不侵犯任何第三方知识产权的暗示担保。

这些资源可供使用 TI 产品进行设计的熟练开发人员使用。您将自行承担以下全部责任：(1) 针对您的应用选择合适的 TI 产品，(2) 设计、验证并测试您的应用，(3) 确保您的应用满足相应标准以及任何其他功能安全、信息安全、监管或其他要求。

这些资源如有变更，恕不另行通知。TI 授权您仅可将这些资源用于研发本资源所述的 TI 产品的应用。严禁对这些资源进行其他复制或展示。您无权使用任何其他 TI 知识产权或任何第三方知识产权。您应全额赔偿因在这些资源的使用中对 TI 及其代表造成的任何索赔、损害、成本、损失和债务，TI 对此概不负责。

TI 提供的产品受 [TI 的销售条款](#) 或 [ti.com](#) 上其他适用条款/TI 产品随附的其他适用条款的约束。TI 提供这些资源并不会扩展或以其他方式更改 TI 针对 TI 产品发布的适用的担保或担保免责声明。

TI 反对并拒绝您可能提出的任何其他或不同的条款。

邮寄地址：Texas Instruments, Post Office Box 655303, Dallas, Texas 75265

Copyright © 2024，德州仪器 (TI) 公司