

TPS7H3014-SP 耐辐射、14V、4 通道序列发生器

1 特性

- 辐射性能：
 - 耐辐射加固保障 (RHA) 高达 100krad(Si) 总电离剂量 (TID)
 - 单粒子锁定 (SEL)、单粒子烧毁 (SEB) 和单粒子栅穿 (SEGR) 对于线性能量传递 (LET) 的抗扰度高达 75MeV-cm²/mg
 - 单粒子功能中断 (SEFI) 和单粒子瞬变 (SET) 对于 LET 的额定值高达 75MeV-cm²/mg
- 宽电源输入电压范围 (V_{IN})：3V 至 14V
- 使用单个器件对多达 4 个电压轨进行定序和监控
 - 菊花链连接功能支持扩展的通道数
- 单电阻器可编程全局计时器用于：
 - 定序开启和关闭延迟
 - 定序开启到稳压的时间
- 倒序定序关闭
- 高精度阈值电压和迟滞电流
 - 电压、温度和辐射 (TID) 范围内的 V_{TH_SENSEx} 为 $599mV \pm 1\%$
 - 电压、温度和辐射 (TID) 范围内的 I_{HYS_SENSEx} 为 $24 \mu A \pm 3\%$
- 具有 1.6V 至 7V 可编程上拉电压的推挽输出
 - 全局 ENx 上拉域 (V_{PULL_UP1})
 - 通用 SEQ_DONE 和 PWRGD 上拉域 (V_{PULL_UP2})
- FAULT 开漏输出，用于监控状态机引起的故障
- 支持军用 (- 55°C 至 125°C) 温度范围

2 应用

- 卫星电力系统 (EPS)
- 复杂数字处理器的控制序列和监控，例如：适用于航天应用的 FPGA、SoC、AFE 和电源系统

3 说明

TPS7H3014 是一款集成式 3V 至 14V、四通道耐辐射加固保障电源序列发生器。通过在菊花链配置中连接多个器件可扩展通道数。该器件可为具有高电平有效 (“开启”) 输入的集成电路 (IC) 提供定序开启和关闭控制信号。此外，还提供了 SEQ_DONE 和 PWRGD 标志，用于监控电源树的序列和电源状态。

精确的 $599mV \pm 1\%$ 阈值电压和 $24 \mu A \pm 3\%$ 迟滞电流提供可编程上升和下降监控电压。上升和下降延迟时间可通过单个电阻进行全局编程。此外，提供的至稳压时间计时器可跟踪 SENSEx 上的上升电压。除了这些特性外，该器件还包含一个故障检测引脚，用于监控内部产生的故障并为电源时序航天应用提供更高的系统级可靠性。QML 型号 5962R2320101VXC 提供了标准微电路图 (SMD)。

器件信息

器件型号 ⁽¹⁾	GRADE ⁽²⁾	封装 ⁽³⁾
5962R2320101VXC	QMLV-RHA	22 引脚陶瓷 (CFP) 6.21mm x 7.69mm 质量 = 415.6mg
TPS7H3014HFT/EM	工程样片	

- 有关更多信息，请查看 [器件选项表](#)。
- 有关器件等级的其他信息，请查看 [SLYB235](#)。
- 尺寸和质量为标称值。

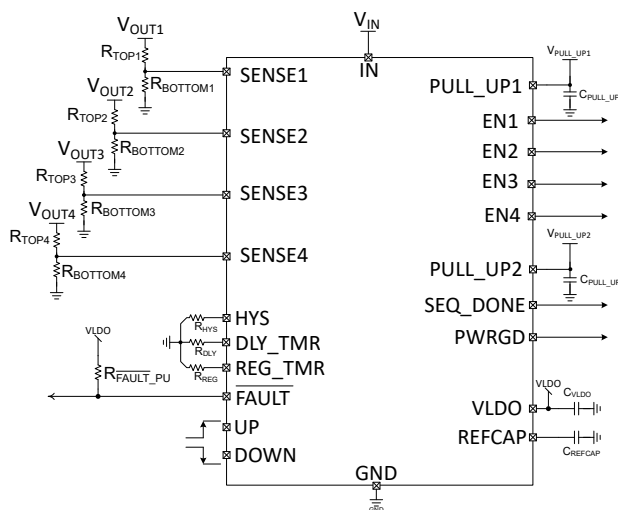

典型应用



Table of Contents

1 特性	1	8.3 Feature Description.....	23
2 应用	1	8.4 Daisy Chain.....	39
3 说明	1	9 Application and Implementation	40
4 Device Options	3	9.1 Application Information.....	40
5 Pin Configuration and Functions	4	9.2 Typical Application.....	40
6 Specifications	6	9.3 Externally Induced System RESET	49
6.1 Absolute Maximum Ratings.....	6	9.4 Power Supply Recommendations.....	49
6.2 ESD Ratings.....	6	9.5 Layout.....	49
6.3 Recommended Operating Conditions.....	7	10 Device and Documentation Support	52
6.4 Thermal Information.....	7	10.1 Documentation Support.....	52
6.5 Electrical Characteristics.....	8	10.2 接收文档更新通知.....	52
6.6 Timing Requirements.....	11	10.3 支持资源.....	52
6.7 Quality Conformance Inspection.....	11	10.4 Trademarks.....	52
6.8 Typical Characteristics.....	12	10.5 静电放电警告.....	52
7 Parameter Measurement Information	17	10.6 术语表.....	52
8 Detailed Description	21	11 Revision History	52
8.1 Overview.....	21	12 Mechanical, Packaging, and Orderable Information	53
8.2 Functional Block Diagram.....	22		

4 Device Options

GENERIC PART NUMBER	RADIATION RATING ⁽¹⁾	GRADE ⁽²⁾	PACKAGE	ORDERABLE PART NUMBER
TPS7H3014-SP	TID of 100krad(Si) RLAT, DSEE free to 75 MeV-cm ² /mg	QMLV-RHA	22-pin CFP HFT	5962R2320101VXC
	None	Engineering model ⁽³⁾	22-pin CFP HFT	TPS7H3014HFT/EM

- (1) TID is total ionizing dose and DSEE is destructive single event effects. Additional information is available in the associated TID reports and SEE reports for each product.
- (2) For additional information about part grade, view [SLYB235](#).
- (3) These units are intended for engineering evaluation only. They are processed to a non-compliant flow (such as no burn-in and only 25°C testing). These units are not suitable for qualification, production, radiation testing, or flight use. Parts are not warranted as to performance over temperature or operating life.

5 Pin Configuration and Functions



图 5-1. HFT Package, 22-Pin CFP (Top View)

表 5-1. Pin Functions

PIN		I/O ⁽¹⁾	DESCRIPTION
NAME	NO.		
SENSE1	1	I	Non-inverting input of the comparator used to monitor the first rail to be sequenced up/down. To set the V_{ON} and V_{OFF} voltages, connect an external resistive divider between the rail to be monitored and GND with the middle point tied to SENSE1. A voltage greater than 599mV (typ) on this pin is considered as a regulated voltage rail (V_{ON}). The V_{OFF} is set by the I_{HYS} current and the top resistor from the resistive divider. Refer to Top and Bottom Resistive Divider Design Equations .
SENSE2	2	I	Non-inverting input of the comparator used to monitor the second rail to be sequenced up/down. To set the V_{ON} and V_{OFF} voltages, connect an external resistive divider between the rail to be monitored and GND with the middle point tied to SENSE2. A voltage greater than 599mV (typ) on this pin is considered as a regulated voltage rail (V_{ON}). The V_{OFF} is set by the I_{HYS} current and the top resistor from the resistive divider. Refer to Top and Bottom Resistive Divider Design Equations .
SENSE3	3	I	Non-inverting input of the comparator used to monitor the third rail to be sequenced up/down. To set the V_{ON} and V_{OFF} voltages, connect an external resistive divider between the rail to be monitored and GND with the middle point tied to SENSE3. A voltage greater than 599mV (typ) on this pin is considered as a regulated voltage rail (V_{ON}). The V_{OFF} is set by the I_{HYS} current and the top resistor from the resistive divider. Refer to Top and Bottom Resistive Divider Design Equations .
SENSE4	4	I	Non-inverting input of the comparator used to monitor the fourth rail to be sequenced up/down. To set the V_{ON} and V_{OFF} voltages, connect an external resistive divider between the rail to be monitored and GND with the middle point tied to SENSE4. A voltage greater than 599mV (typ) on this pin is considered as a regulated voltage rail (V_{ON}). The V_{OFF} is set by the I_{HYS} current and the top resistor from the resistive divider. Refer to Top and Bottom Resistive Divider Design Equations .
REFCAP	5	O	1.2V internal reference. Requires a 470nF external capacitor to GND. Do not load this pin.
HYS	6	O	Hysteresis. Connect a 50k Ω resistor between this pin and GND, to program the hysteresis current (typically 24 μ A) at SENSE1 to SENSE4. Is recommended using a resistor with a 0.1% or better tolerance for hysteresis current accuracy.
FAULT	7	O	FAULT. Open drain output which is forced low by the state machine to indicate an internally generated fault. Is recommended to pull-up this pin to VLDO with a 10k Ω resistor. However, a different external voltage source can be used as the pull-up as long as it is stable before commanding the sequence up and never drops below 1V during the operation of the device.

表 5-1. Pin Functions (续)

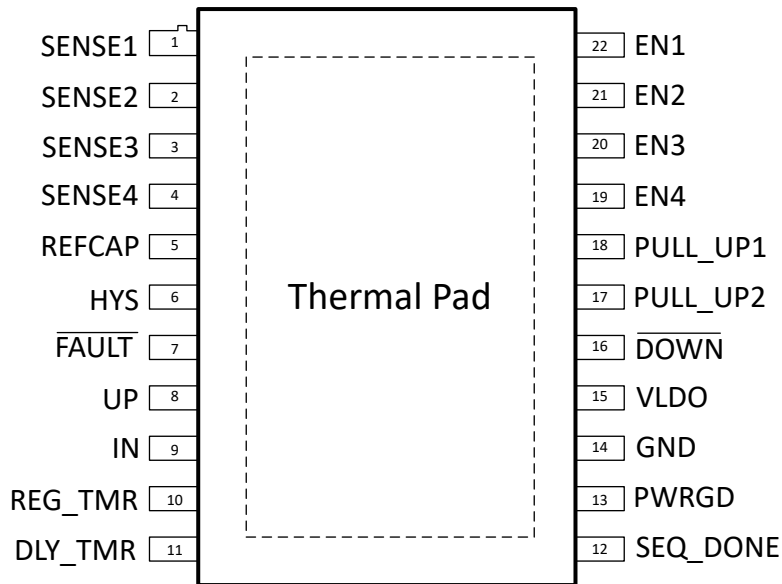
PIN		I/O ⁽¹⁾	DESCRIPTION
NAME	NO.		
UP	8	I	Non-inverting input of a comparator. A rising voltage greater than 599mV (typ) will induce a rising edge and will start a sequence up. This pin can be driven by an external controller, or connected to a main rail through an external resistive divider with the middle point connected to the UP pin to start the sequence up automatically. This threshold has a fixed hysteresis of 100mV (typ).
IN	9	I	Input supply to the device. Input voltage range is from 3V to 14V. Connect at least a 0.1 μ F ceramic capacitor as close as possible to the pin.
REG_TMR	10	I/O	Time to regulation timer. Connect a resistor to GND between 10.5k Ω and 1.18M Ω to set the allowed time for a SENSE _x rail to reach the regulation threshold (V _{ON}). The delay can be adjusted from 0.25ms to 25ms. Leave this pin floating to deactivate this feature.
DLY_TMR	11	I/O	Delay timer. Connect a resistor to GND between 10.5k Ω and 1.18M Ω to set the sequence up and down delay. The delay can be adjusted from 0.25ms to 25ms. Leave this pin floating for no delay.
SEQ_DONE	12	O	Sequence done. Push-pull output with V _{OH} level set by PULL_UP2 input supply voltage. Indicates when the sequence up or down is completed.
PWRGD	13	O	Power Good. Push-pull output with V _{OH} level set by PULL_UP2 input supply voltage. Indicates when all rails (SENSE1 to SENSE4) are in regulation (greater than V _{ONx}).
GND	14	—	Ground.
VLDO	15	O	Output of internal regulator. Requires at least 1 μ F external ceramic capacitor to GND. Allowed loading of this regulator are: $\overline{\text{FAULT}}$ pull-up using a 10k Ω resistor or to turn-off unused channels by connecting directly to SENSE2 to SENSE4 as needed.
DOWN	16	I	Non-inverting input of a comparator. A falling voltage lower than 498mV (typ) will induce a falling edge and will start a sequence down. This pin can be driven by an external controller, or connected to a main rail through an external resistive divider with the middle point connected to the DOWN pin to start the sequence down automatically. This threshold has a fixed hysteresis of 100mV (typ).
PULL_UP2	17	I	Input supply voltage to program the pull-up voltage for the push-pull output stage on SEQ_DONE and PWRGD. Connect at least a 1 μ F ceramic capacitor as close as possible to the pin.
PULL_UP1	18	I	Input supply voltage to program the global pull-up voltage for the push-pull output stages on EN1 to EN4. Connect at least a 1 μ F ceramic capacitor as close as possible to the pin.
EN4	19	O	Enable 4. Push pull output with V _{OH} level set by the PULL_UP1 input supply voltage. Connect to the logic enable signal of the device to control and to be monitored by SENSE4.
EN3	20	O	Enable 3. Push pull output with V _{OH} level set by the PULL_UP1 input supply voltage. Connect to the logic enable signal of the device to control and to be monitored by SENSE3.
EN2	21	O	Enable 2. Push pull output with V _{OH} level set by the PULL_UP1 input supply voltage. Connect to the logic enable signal of the device to control and to be monitored by SENSE2.
EN1	22	O	Enable 1. Push pull output with V _{OH} level set by the PULL_UP1 input supply voltage. Connect to the logic enable signal of the device to control and to be monitored by SENSE1.
Thermal pad		—	Internally grounded. It is recommended to connect this metal thermal pad to a large ground plane for effective heat dissipation.
Metal lid	Lid	—	The lid is internally connected to the thermal pad and GND through the seal ring.

(1) I = Input, O = Output, I/O = Input or Output, — = Other

6 Specifications

6.1 Absolute Maximum Ratings

over operating free-air temperature range (unless otherwise noted) ⁽¹⁾ ⁽²⁾

		MIN	MAX	UNIT
Input voltage	IN	- 0.3	16	V
	UP, DOWN	- 0.3	7.5	
	SENSE1, SENSE2, SENSE3, SENSE4	- 0.3	3.6	
	PULL_UP1, PULL_UP2	- 0.3	7.5	
	FAULT	- 0.3	7.5	
	DLY_TMR, REG_TMR	- 0.3	3.6	
Output voltage	VLDO	- 0.3	3.6	V
	EN1, EN2, EN3, EN4	- 0.3	7.5	
	REFCAP	- 0.3	2	
	HYS	- 0.3	3.6	
	SEQ_DONE, PWRGD	- 0.3	7.5	
Output current	EN1, EN2, EN3, EN4	- 20	20	mA
	SEQ_DONE, PWRGD	- 20	20	
Junction temperature	T _J	- 55	150	°C
Storage temperature	T _{stg}	- 65	150	°C

- (1) Operation outside the Absolute Maximum Ratings may cause permanent device damage. Absolute Maximum Ratings do not imply functional operation of the device at these or any other conditions beyond those listed under Recommended Operating Conditions. If used outside the Recommended Operating Conditions but within the Absolute Maximum Ratings, the device may not be fully functional, and this may affect device reliability, functionality, performance, and shorten the device lifetime.
- (2) All voltages values are with respect to GND.

6.2 ESD Ratings

			VALUE	UNIT
V _{ESD}	Electrostatic discharge	Human body model (HBM), per ANSI/ESDA/ JEDEC JS-001, all pins ⁽¹⁾	±2000	V
		Charged-device model (CDM), per ANSI/ESDA/ JEDEC JS-002, all pins ⁽²⁾	±500	

- (1) JEDEC document JEP155 states that 500V HBM allows safe manufacturing with a standard ESD control process.
- (2) JEDEC document JEP157 states that 250V CDM allows safe manufacturing with a standard ESD control process.

6.3 Recommended Operating Conditions

over operating temperature range, $T_A = -55^{\circ}\text{C}$ to 125°C (unless otherwise noted) ⁽¹⁾

		MIN	NOM	MAX	UNIT
Input voltage	IN	3		14	V
	UP, $\overline{\text{DOWN}}$	0		7	
	SENSE1, SENSE2, SENSE3, SENSE4	0		3.5	
	PULL_UP1, PULL_UP2	1.6		7	
	FAULT	0		7	
Output voltage	EN1, EN2, EN3, EN4	0		7	V
	SEQ_DONE, PWRGD	0		7	
Output current	EN1, EN2, EN3, EN4	- 10		10	mA
	SEQ_DONE, PWRGD	- 10		10	
	FAULT	- 2			
Junction temperature	T_J	- 55		125	$^{\circ}\text{C}$
Input voltage slew rate	SR_{IN}	0.001		10	$\text{V}/\mu\text{s}$

(1) All voltages values are with respect to GND.

6.4 Thermal Information

THERMAL METRIC ⁽¹⁾		TPS7H3014-SP	
		HFT (CFP)	
		22 pins	
			UNIT
$R_{\theta \text{ JA}}$	Junction-to-ambient thermal resistance	34.2	$^{\circ}\text{C}/\text{W}$
$R_{\theta \text{ JC(bot)}}$	Junction-to-case (bottom) thermal resistance	7.7	$^{\circ}\text{C}/\text{W}$
$R_{\theta \text{ JB}}$	Junction-to-board thermal resistance	17.2	$^{\circ}\text{C}/\text{W}$
$R_{\theta \text{ JC(top)}}$	Junction-to-case (top) thermal resistance	16.9	$^{\circ}\text{C}/\text{W}$
Ψ_{JT}	Junction-to-top characterization parameter	8.6	$^{\circ}\text{C}/\text{W}$
Ψ_{JB}	Junction-to-board characterization parameter	17	$^{\circ}\text{C}/\text{W}$

(1) For more information about traditional and new thermal metrics, see the [Semiconductor and IC Package Thermal Metrics](#) application report.

6.5 Electrical Characteristics

Over $3V \leq V_{IN} \leq 14V$, $R_{DLY_TMR} = 10.5k\Omega$, $R_{REG_TMR} = 10.5k\Omega$, $C_{REFCAP} = 470nF$, $C_{VLDO} = 1\mu F$, $V_{PULL_UP1} = 3.3V$, $V_{PULL_UP2} = 3.3V$, $C_{PULL_UP1} = 1\mu F$, $C_{PULL_UP2} = 1\mu F$, over temperature range ($T_A = -55^\circ C$ to $125^\circ C$), unless otherwise noted; includes group E radiation testing at $T_A = 25^\circ C$ for QML RHA devices ^{(1) (2)}

PARAMETER		TEST CONDITIONS	SUB-GROUP ⁽³⁾	MIN	TYP	MAX	UNIT	
SUPPLY VOLTAGES AND CURRENTS								
I_{Q_IN}	V_{IN} quiescent current	In Waiting to sequence up and down states with all outputs floating. See State Diagram	1, 2, 3		2.5	4	mA	
$UVLO_{RISE}$	V_{IN} rising undervoltage lockout		1, 2, 3	2.72	2.79	2.84	V	
$UVLO_{FALL}$	V_{IN} falling undervoltage lockout		1, 2, 3	2.59	2.64	2.69		
V_{LDO}	Internal linear regulator output voltage	$5V \leq V_{IN} \leq 14V$	1, 2, 3	3.19	3.29	3.38	V	
		$V_{IN} < 3.24V$	1, 2, 3	97%	99%		$\times V_{IN}$	
REFCAP	Internal bandgap voltage		1, 2, 3	1.188	1.2	1.212	V	
V_{POR_IN}	Power on reset voltage ⁽⁴⁾	$1.6V \leq V_{PULL_UPx} \leq 7V$, $V_{OL} \leq 320mV$ with $I_{ENx} = -2mA$	1, 2, 3		1.41	2		
$V_{POR_PULL_UPx}$	Power on reset voltage ⁽⁵⁾	$V_{IN} = 0V$, $V_{OL} \leq 320mV$ with $I_{ENx} = -100\mu A$	1, 2, 3		0.89	1.4		
SENSE1 TO SENSE4, UP AND DOWN COMPARATOR INPUTS								
V_{TH_SENSEx}	Threshold voltage at SENSE _x		1, 2, 3	593	599	605	mV	
I_{HYS_SENSEx}	SENSE _x hysteresis current	$V_{SENSEx} = 700mV$	1, 2, 3	23.28	24	24.72	μA	
I_{LKG_SENSEx}	Input leakage current at SENSE _x	$V_{SENSEx} = 500mV$	1, 2, 3		2	100	nA	
V_{TH_UP}	Rising threshold voltage at UP		1, 2, 3	580	598	615	mV	
V_{TH_DOWN}	Falling threshold voltage at DOWN		1, 2, 3	483	498	512	mV	
$V_{HYS_UP_DOWN}$	UP and DOWN hysteresis voltage		1, 2, 3		100		mV	
$I_{LKG_UP_DOWN}$	Input leakage current at UP and DOWN	$V_{UP} = V_{DOWN} = 500mV$	1, 2, 3		2	100	nA	
V_{TURN_OFF}	Channel 2, 3, 4 turn off voltage		1, 2, 3	87%	89%	91%	$\times VLDO$	
EN1 TO EN4, SEQ_DONE AND PWRGD PUSH PULL OUTPUTS								
V_{OL_ENx}	Low-level EN _x output voltage	$1.6V \leq V_{PULL_UP1} \leq 7V$	$I_{LOAD} = -2mA$	1, 2, 3			10%	x V_{PULL_UP1}
			$I_{LOAD} = -10mA$	1, 2, 3			25%	
V_{OH_ENx}	High-level EN _x output voltage	$1.6V \leq V_{PULL_UP1} \leq 7V$	$I_{LOAD} = 2mA$	1, 2, 3			90%	x V_{PULL_UP1}
			$I_{LOAD} = 10mA$	1, 2, 3			70%	
$V_{OL_SEQ_DONE}$	Low-level SEQ_DONE output voltage	$1.6V \leq V_{PULL_UP2} \leq 7V$	$I_{LOAD} = -2mA$	1, 2, 3			10%	x V_{PULL_UP2}
			$I_{LOAD} = -10mA$	1, 2, 3			25%	
$V_{OH_SEQ_DONE}$	High-level SEQ_DONE output voltage	$1.6V \leq V_{PULL_UP2} \leq 7V$	$I_{LOAD} = 2mA$	1, 2, 3			90%	x V_{PULL_UP2}
			$I_{LOAD} = 10mA$	1, 2, 3			70%	
V_{OL_PWRGD}	Low-level PWRGD output voltage	$1.6V \leq V_{PULL_UP2} \leq 7V$	$I_{LOAD} = -2mA$	1, 2, 3			10%	x V_{PULL_UP2}
			$I_{LOAD} = -10mA$	1, 2, 3			25%	
V_{OH_PWRGD}	High-level PWRGD output voltage	$1.6V \leq V_{PULL_UP2} \leq 7V$	$I_{LOAD} = 2mA$	1, 2, 3			90%	x V_{PULL_UP2}
			$I_{LOAD} = 10mA$	1, 2, 3			70%	

6.5 Electrical Characteristics (续)

Over $3V \leq V_{IN} \leq 14V$, $R_{DLY_TMR} = 10.5k\Omega$, $R_{REG_TMR} = 10.5k\Omega$, $C_{REFCAP} = 470nF$, $C_{VLDO} = 1\mu F$, $V_{PULL_UP1} = 3.3V$, $V_{PULL_UP2} = 3.3V$, $C_{PULL_UP1} = 1\mu F$, $C_{PULL_UP2} = 1\mu F$, over temperature range ($T_A = -55^\circ C$ to $125^\circ C$), unless otherwise noted; includes group E radiation testing at $T_A = 25^\circ C$ for QML RHA devices ^{(1) (2)}

PARAMETER		TEST CONDITIONS		SUB-GROUP ⁽³⁾	MIN	TYP	MAX	UNIT
PULL_UPxLKG	PULL_UPx leakage current	$V_{PULL_UPx} = 7V$		1, 2, 3		48	121	μA
SR _{ENx_RISE}	Enable rising output voltage slew rate	10% to 90% of V_{PULL_UP1} , $R_{LOAD} = 50k\Omega$, $C_{LOAD} = 100pF$	$1.6V \leq V_{PULL_UP1} \leq 7V$	9, 10, 11		17	125	V/ μs
SR _{SEQ_DONE_RISE}	SEQ_DONE rising output voltage slew rate	10% to 90% of V_{PULL_UP2} , $R_{LOAD} = 50k\Omega$, $C_{LOAD} = 100pF$	$1.6V \leq V_{PULL_UP2} \leq 7V$	9, 10, 11		17	125	
SR _{PWRGD_RISE}	PWRGD rising output voltage slew rate	$R_{LOAD} = 50k\Omega$, $C_{LOAD} = 100pF$	$1.6V \leq V_{PULL_UP2} \leq 7V$	9, 10, 11		17	125	
SR _{ENx_FALL}	Enable falling output voltage slew rate	90% to 10% of V_{PULL_UP1} , $R_{LOAD} = 50k\Omega$, $C_{LOAD} = 100pF$	$1.6V \leq V_{PULL_UP1} \leq 7V$	9, 10, 11		44	126	
SR _{SEQ_DONE_FALL}	SEQ_DONE falling output voltage slew rate	$R_{LOAD} = 50k\Omega$, $C_{LOAD} = 100pF$	$1.6V \leq V_{PULL_UP2} \leq 7V$	9, 10, 11		44	126	
SR _{PWRGD_FALL}	PWRGD falling output voltage slew rate		$1.6V \leq V_{PULL_UP2} \leq 7V$	9, 10, 11		44	126	
R _{ENx_PULL_UP}	EN PMOS source output resistance	$I_{LOAD} = 2mA$	$V_{PULL_UP1} = 1.6V$ $V_{PULL_UP1} = 7V$	1, 2, 3 1, 2, 3		18 7	40 20	Ω
R _{SEQ_DONE_PULL_UP}	SEQ_DONE PMOS source output resistance	$I_{LOAD} = 2mA$	$V_{PULL_UP2} = 1.6V$ $V_{PULL_UP2} = 7V$	1, 2, 3 1, 2, 3		18 7	40 20	
R _{PWRGD_PULL_UP}	PWRGD PMOS source output resistance	$I_{LOAD} = 2mA$	$V_{PULL_UP2} = 1.6V$ $V_{PULL_UP2} = 7V$	1, 2, 3 1, 2, 3		18 7	40 20	
R _{ENx_PULL_DOWN}	EN NMOS sink output resistance	$I_{LOAD} = -2mA$, $1.6V \leq V_{PULL_UP1} \leq 7V$		1, 2, 3		7	28	
R _{SEQ_DONE_PULL_DOWN}	SEQ_DONE NMOS sink output resistance	$I_{LOAD} = -2mA$, $1.6V \leq V_{PULL_UP1} \leq 7V$		1, 2, 3		7	28	
R _{PWRGD_PULL_DOWN}	PWRGD NMOS sink output resistance	$I_{LOAD} = -2mA$, $1.6V \leq V_{PULL_UP1} \leq 7V$		1, 2, 3		7	28	
FAULT OUTPUT								
R _{FAULT_PULL_DOWN}	FAULT pull down resistance	$I_{FAULT} = 100\mu A$		1, 2, 3		131	512	Ω
I _{LKG_FAULT}	FAULT leakage current	$V_{FAULT} = 7V$		1, 2, 3		23	600	nA
THERMAL PROTECTION								
T _{SD_ENTER}	Thermal shutdown enter temperature					177		$^\circ C$
T _{SD_EXIT}	Thermal shutdown exit temperature					164		

6.5 Electrical Characteristics (续)

Over $3V \leq V_{IN} \leq 14V$, $R_{DLY_TMR} = 10.5k\Omega$, $R_{REG_TMR} = 10.5k\Omega$, $C_{REFCAP} = 470nF$, $C_{VLDO} = 1\mu F$, $V_{PULL_UP1} = 3.3V$, $V_{PULL_UP2} = 3.3V$, $C_{PULL_UP1} = 1\mu F$, $C_{PULL_UP2} = 1\mu F$, over temperature range ($T_A = -55^\circ C$ to $125^\circ C$), unless otherwise noted; includes group E radiation testing at $T_A = 25^\circ C$ for QML RHA devices ⁽¹⁾ ⁽²⁾

PARAMETER		TEST CONDITIONS	SUB-GROUP ⁽³⁾	MIN	TYP	MAX	UNIT
DELAY AND TIME TO REGULATION TIMERS							
t_{DLY_TMR}	Delay time	$R_{DLY_TMR} = 10.5k\Omega$	9, 10, 11	0.205	0.268	0.342	ms
		$R_{DLY_TMR} = 619k\Omega$	9, 10, 11	10.77	12.5	14.14	
		$R_{DLY_TMR} = 1.18M\Omega$	9, 10, 11	20	23.37	27.2	
t_{REG_TMR}	Time to regulation	$R_{REG_TMR} = 10.5k\Omega$	9, 10, 11	0.197	0.264	0.34	
		$R_{REG_TMR} = 619k\Omega$	9, 10, 11	10.8	12.4	14.1	
		$R_{REG_TMR} = 1.18M\Omega$	9, 10, 11	20.3	23.63	27.2	

- (1) See the 5962R2320101VXC SMD (standard microcircuit drawing) for additional information on the RHA devices.
- (2) All voltage values are with respect to GND.
- (3) For subgroup definitions, see [Quality Conformance Inspection](#) table.
- (4) V_{POR_IN} is the minimum V_{IN} voltage for a controlled output state, when $1.6V \leq V_{PULL_UPx} \leq 7V$. Below V_{POR_IN} , the output cannot be determined.
- (5) $V_{POR_PULL_UPx}$ is the minimum V_{PULL_UPx} voltage for a controlled output state, when $V_{IN} \leq 3V$. Below $V_{POR_PULL_UPx}$ the output cannot be determined.

6.6 Timing Requirements

Over $3V \leq V_{IN} \leq 14V$, $R_{DLY_TMR} = 10.5k\Omega$, $R_{REG_TMR} = 10.5k\Omega$, $C_{REFCAP} = 470nF$, $C_{VLDO} = 1\mu F$, $V_{PULL_UP1} = 3.3V$, $V_{PULL_UP2} = 3.3V$, $C_{PULL_UP1} = 1\mu F$, $C_{PULL_UP2} = 1\mu F$, over temperature range ($T_A = -55^\circ C$ to $125^\circ C$) unless otherwise noted; includes group E radiation testing at $T_A = 25^\circ C$ for RHA devices ⁽¹⁾

PARAMETER		TEST CONDITIONS	SUB-GROUP ⁽²⁾	MIN	TYP	MAX	UNIT
$t_{Start_up_delay}$	Start-up delay time ⁽³⁾	$V_{REFCAP} \geq 1.1V$, See Figure 7-1	9, 10, 11			2.8	ms
t_{pd_ENx}	ENx propagation delay	DLY_TMR = Open, REG_TMR=Open, See Figure 7-2 and Figure 7-3	9, 10, 11		3.4	6.5	μs
$t_{pd_SEQ_DONE}$	SEQ_DONE propagation delay	DLY_TMR = Open, REG_TMR=Open, See Figure 7-4 and Figure 7-5	9, 10, 11		3.4	6.5	
t_{pd_PWRGD}	PWRGD propagation delay	DLY_TMR = Open, REG_TMR=Open, See Figure 7-6 and Figure 7-7	9, 10, 11		3.4	6.5	
$t_{pd_SM_FAULT}$	State machine fault propagation delay	In Waiting to Sequence DOWN State from 33% of SENSE1 ↓ to 82% PWRGD ↓ See Figure 7-8 and State Diagram .	9, 10, 11		3.4	4.3	
t_{MIN_UP}	V_{UP} rising minimum time for valid UP	DLY_TMR = Open, See Figure 7-10	9, 10, 11		0.27	0.7	μs
t_{MIN_DOWN}	V_{DOWN} rising minimum time for valid DOWN	DLY_TMR = Open, See Figure 7-11	9, 10, 11		0.42	0.9	
$t_{h_VTH_RISE}$	Rising threshold on VSENSEx hold time	DLY_TMR = Open, See Figure 7-12	9, 10, 11		0.84	1.6	μs
$t_{h_VTH_FALL}$	Falling threshold on VSENSEx hold time	DLY_TMR = Open, See Figure 7-13	9, 10, 11		0.35	1	μs

(1) See the 5962R2320101VXC SMD (standard microcircuit drawing) for additional information on the RHA devices.

(2) For subgroup definitions, see [Quality Conformance Inspection](#) table.

(3) During the power-on, V_{IN} must be at or above V_{IN} (MIN) for at least $t_{Start_up_delay}$ for all internal references to be within specification.

6.7 Quality Conformance Inspection

MIL-STD-883, Method 5005 - Group A

SUBGROUP	DESCRIPTION	TEMP (°C)
1	Static tests at	25
2	Static tests at	125
3	Static tests at	- 55
4	Dynamic tests at	25
5	Dynamic tests at	125
6	Dynamic tests at	- 55
7	Functional tests at	25
8A	Functional tests at	125
8B	Functional tests at	- 55
9	Switching tests at	25
10	Switching tests at	125
11	Switching tests at	- 55

6.8 Typical Characteristics

$R_{DLY_TMR} = 10.5k\Omega$, $R_{REG_TMR} = 10.5k\Omega$, $V_{PULL_UP1} = 3.3V$, $V_{PULL_UP2} = 3.3V$, $V_{FAULT} = 10k\Omega$ pull-up to VLDO, $R_{HYS} = 50k\Omega$, $C_{REFCAP} = 470nF$, $C_{VLDO} = 1\mu F$, $C_{PULL_UP1} = 1\mu F$, $C_{PULL_UP2} = 1\mu F$, unless otherwise noted.

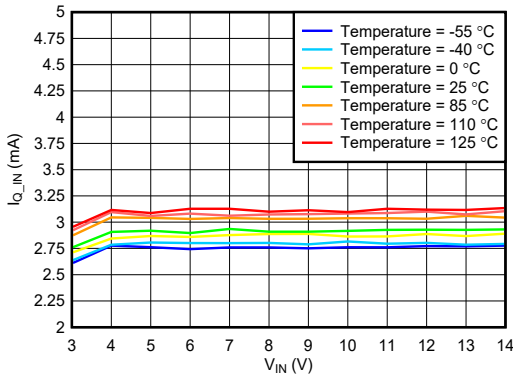

$V_{UP} = V_{DOWN} = 0V$

图 6-1. I_{Q_IN} vs V_{IN} Across Temperature in Waiting to Sequence UP State

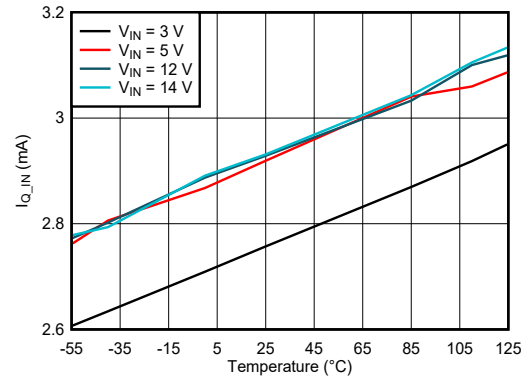

$V_{UP} = V_{DOWN} = 0V$

图 6-2. I_{Q_IN} vs Temperature Across V_{IN} in Waiting to Sequence UP State

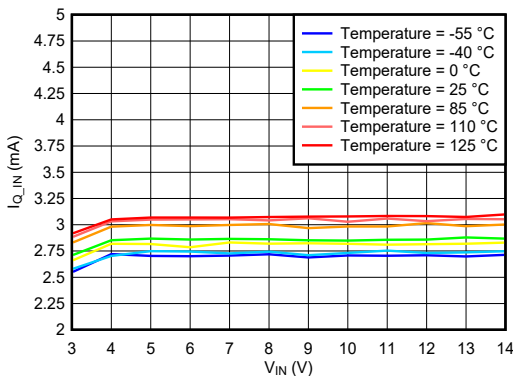

$V_{UP} = V_{DOWN} = 3.3V$

图 6-3. I_{Q_IN} vs V_{IN} Across Temperature in Waiting to Sequence DOWN State

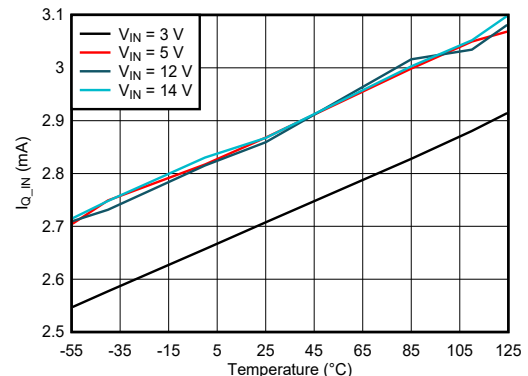

$V_{UP} = V_{DOWN} = 3.3V$

图 6-4. I_{Q_IN} vs Temperature Across V_{IN} in Waiting to Sequence DOWN State

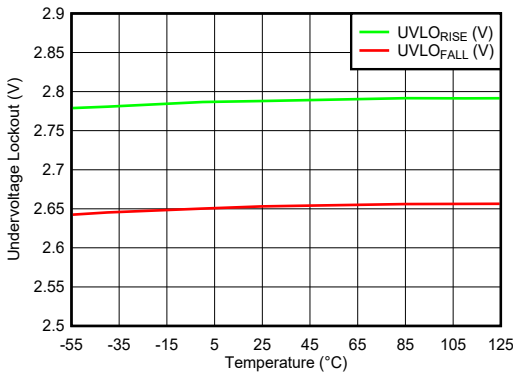

$R_{DLY_TMR} = \text{Floating}$ $V_{UP} = V_{DOWN} = 3.3V$
 $R_{REG_TMR} = 1.18M\Omega$

图 6-5. Undervoltage Lockout vs Temperature

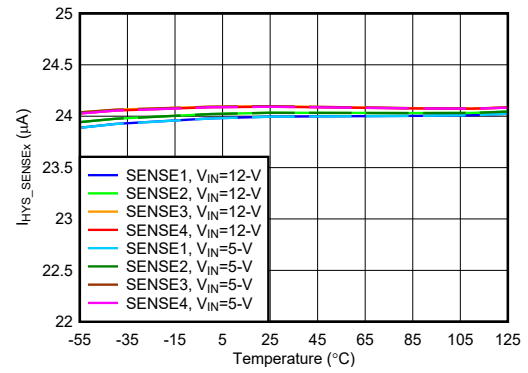

$V_{SENSEX} = 700mV$ $R_{REG_TMR} = \text{Floating}$

图 6-6. I_{HYS_SENSEX} vs Temperature Across V_{IN} and $SENSEX$ Channel

6.8 Typical Characteristics (continued)

$R_{DLY_TMR} = 10.5k\Omega$, $R_{REG_TMR} = 10.5k\Omega$, $V_{PULL_UP1} = 3.3V$, $V_{PULL_UP2} = 3.3V$, $V_{FAULT} = 10k\Omega$ pull-up to VLDO, $R_{HYS} = 50k\Omega$, $C_{REFCAP} = 470nF$, $C_{VLDO} = 1\mu F$, $C_{PULL_UP1} = 1\mu F$, $C_{PULL_UP2} = 1\mu F$, unless otherwise noted.

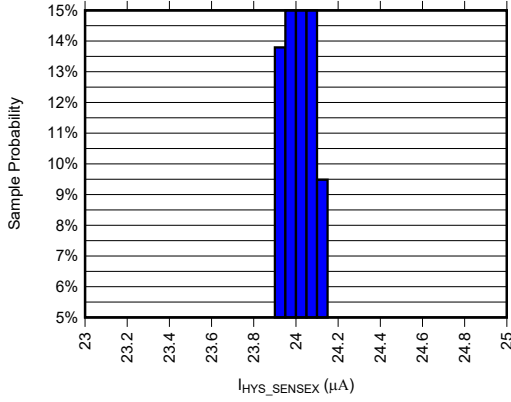

$V_{IN} = 3V$ $V_{SENSEX} = 700mV$

图 6-7. IHYS_SENSEx Current Distribution at Temperature of -55°C

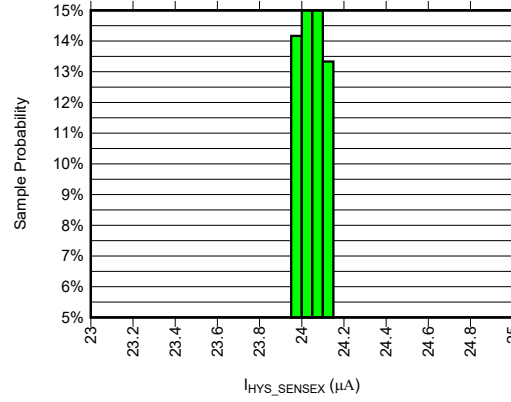

$V_{IN} = 3V$ $V_{SENSEX} = 700mV$

图 6-8. IHYS_SENSEx Current Distribution at Temperature of 25°C

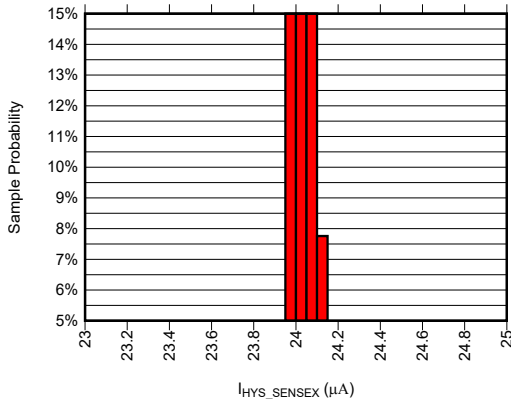

$V_{IN} = 3V$ $V_{SENSEX} = 700mV$

图 6-9. IHYS_SENSEx Current Distribution at Temperature of 125°C



图 6-10. VTH_SENSEx Voltage Distribution at Temperature of -55°C



图 6-11. VTH_SENSEx Voltage Distribution at Temperature of +25°C

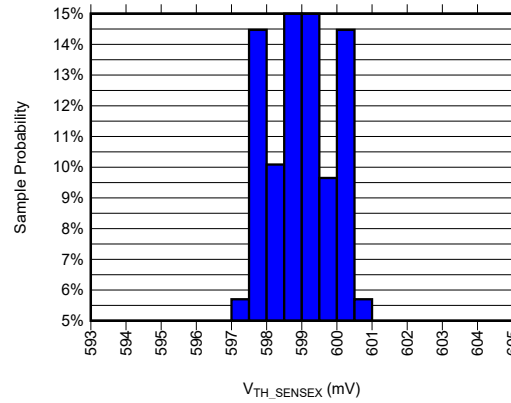

图 6-12. VTH_SENSEx Voltage Distribution at Temperature of 125°C

6.8 Typical Characteristics (continued)

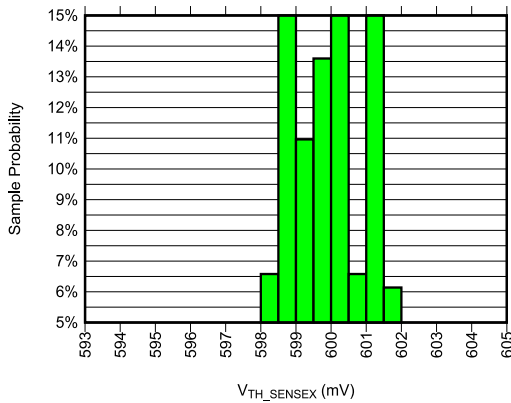
$R_{DLY_TMR} = 10.5k\Omega$, $R_{REG_TMR} = 10.5k\Omega$, $V_{PULL_UP1} = 3.3V$, $V_{PULL_UP2} = 3.3V$, $V_{FAULT} = 10k\Omega$ pull-up to VLDO, $R_{HYS} = 50k\Omega$, $C_{REFCAP} = 470nF$, $C_{VLDO} = 1 \mu F$, $C_{PULL_UP1} = 1 \mu F$, $C_{PULL_UP2} = 1 \mu F$, unless otherwise noted.

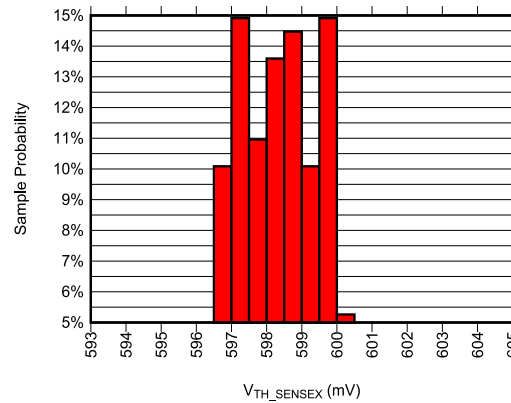
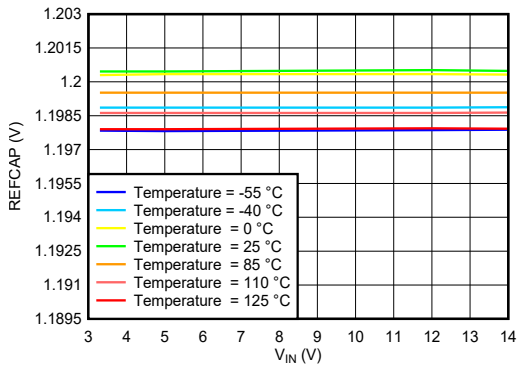

$V_{UP} = V_{DOWN} = 0V$

图 6-13. REFCAP vs V_{IN} Across Temperature

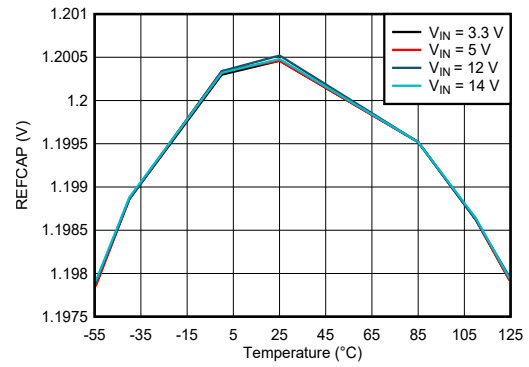

$V_{UP} = V_{DOWN} = 0V$

图 6-14. REFCAP vs Temperature Across V_{IN}

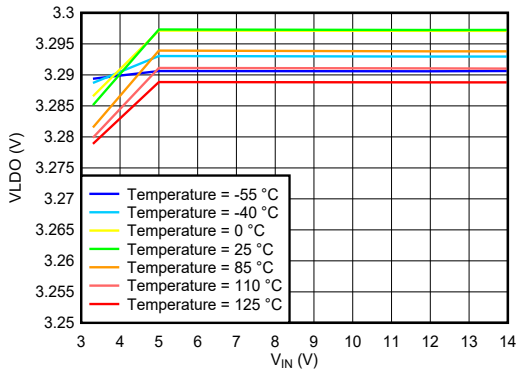

$V_{UP} = V_{DOWN} = 0V$

图 6-15. VLDO vs V_{IN} Across Temperature

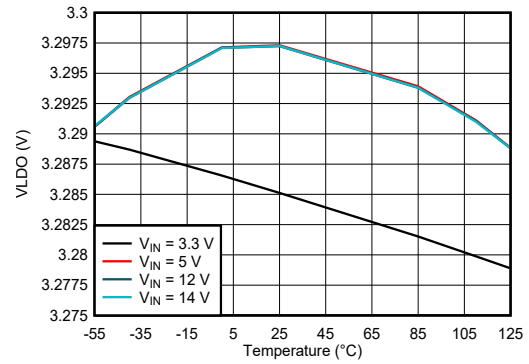

$V_{UP} = V_{DOWN} = 0V$

$R_{REG_TMR} = \text{Floating}$

图 6-16. VLDO vs Temperature Across V_{IN}

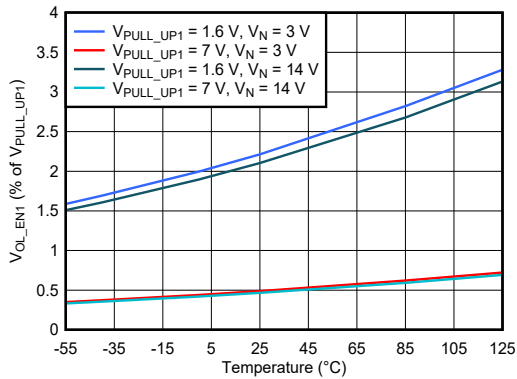

$V_{UP} = V_{DOWN} = 0V$

$I_{LOAD} = -2mA$

$R_{REG_TMR} = \text{Floating}$

图 6-17. V_{OL_EN1} vs Temperature Across V_{PULL_UP1} and V_{IN} at $I_{LOAD} = -2mA$

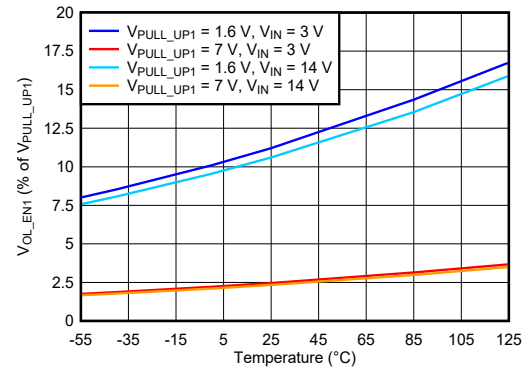

$V_{UP} = V_{DOWN} = 0V$

$I_{LOAD} = -10mA$

$R_{REG_TMR} = \text{Floating}$

图 6-18. V_{OL_EN1} vs Temperature Across V_{PULL_UP1} and V_{IN} at $I_{LOAD} = -10mA$

6.8 Typical Characteristics (continued)

$R_{DLY_TMR} = 10.5k\Omega$, $R_{REG_TMR} = 10.5k\Omega$, $V_{PULL_UP1} = 3.3V$, $V_{PULL_UP2} = 3.3V$, $V_{FAULT} = 10k\Omega$ pull-up to VLDO, $R_{HYS} = 50k\Omega$, $C_{REFCAP} = 470nF$, $C_{VLDO} = 1\mu F$, $C_{PULL_UP1} = 1\mu F$, $C_{PULL_UP2} = 1\mu F$, unless otherwise noted.

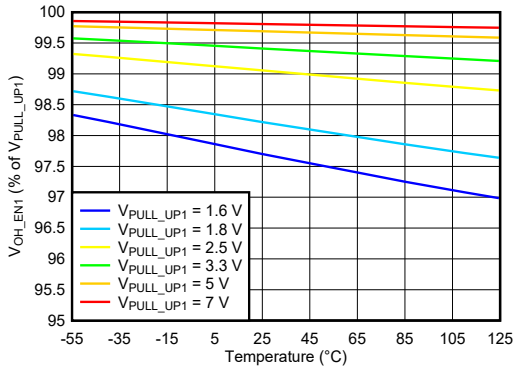

$V_{UP} = V_{DOWN} = 3.3V$ $I_{LOAD} = 2mA$
 $R_{REG_TMR} = Floating$ $V_{IN} = 12V$

图 6-19. V_{OH_EN1} vs Temperature Across V_{PULL_UP1} at $I_{LOAD} = 2mA$

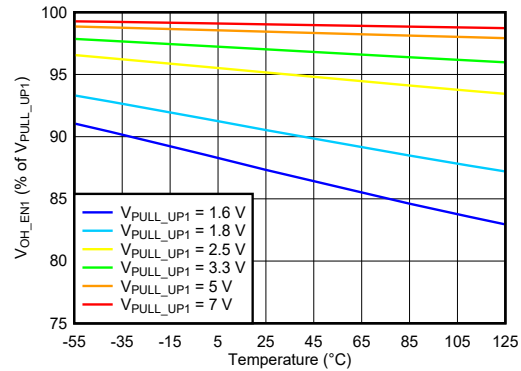

$V_{UP} = V_{DOWN} = 3.3V$ $I_{LOAD} = 10mA$
 $R_{REG_TMR} = Floating$ $V_{IN} = 12V$

图 6-20. V_{OH_EN1} vs Temperature Across V_{PULL_UP1} at $I_{LOAD} = 10mA$

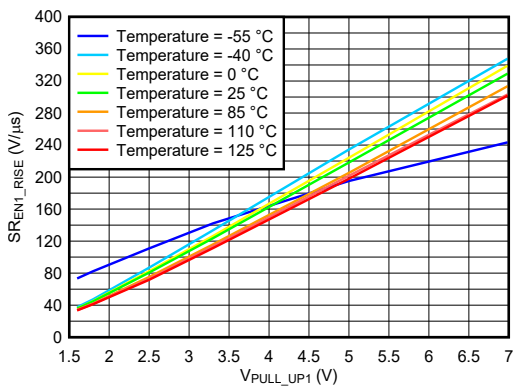

$V_{UP} = V_{DOWN} = \uparrow 3.3V$ $V_{IN} = 12V$
 $R_{REG_TMR} = Floating$

图 6-21. S_{REN1_RISE} vs V_{PULL_UP1} Across Temperature

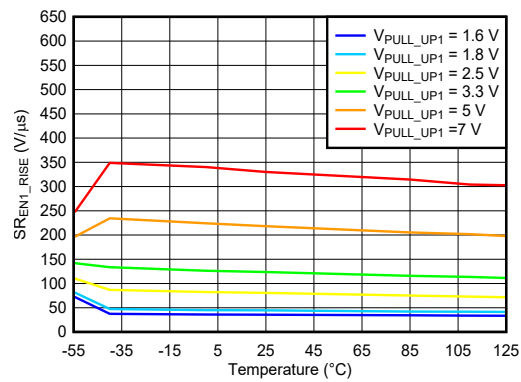

$V_{UP} = V_{DOWN} = \uparrow 3.3V$ $V_{IN} = 12V$
 $R_{REG_TMR} = Floating$

图 6-22. S_{REN1_RISE} vs Temperature Across V_{PULL_UP1}

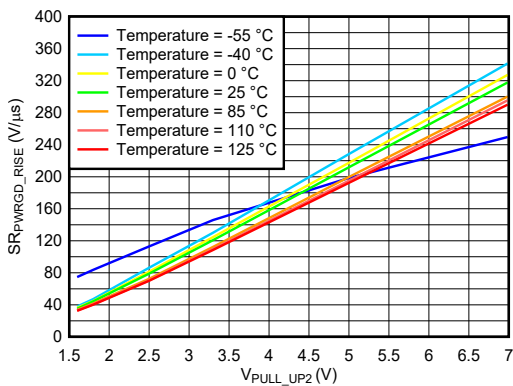

$V_{UP} = V_{DOWN} = \uparrow 3.3V$ $V_{IN} = 12V$
 $R_{REG_TMR} = Floating$

图 6-23. S_{RPWRGD_RISE} vs V_{PULL_UP2} Across Temperature

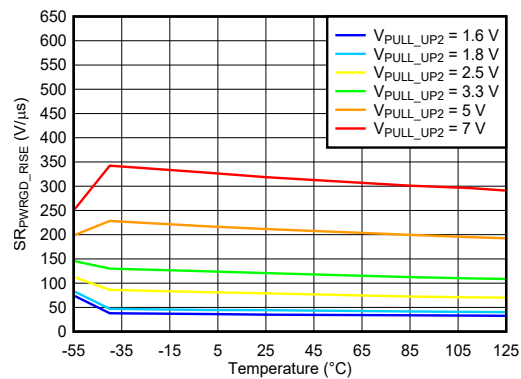

$V_{UP} = V_{DOWN} = \uparrow 3.3V$ $V_{IN} = 12V$
 $R_{REG_TMR} = Floating$

图 6-24. S_{RPWRGD_RISE} vs Temperature Across V_{PULL_UP2}

6.8 Typical Characteristics (continued)

$R_{DLY_TMR} = 10.5k\Omega$, $R_{REG_TMR} = 10.5k\Omega$, $V_{PULL_UP1} = 3.3V$, $V_{PULL_UP2} = 3.3V$, $V_{FAULT} = 10k\Omega$ pull-up to VLDO, $R_{HYS} = 50k\Omega$, $C_{REFCAP} = 470nF$, $C_{VLDO} = 1\mu F$, $C_{PULL_UP1} = 1\mu F$, $C_{PULL_UP2} = 1\mu F$, unless otherwise noted.

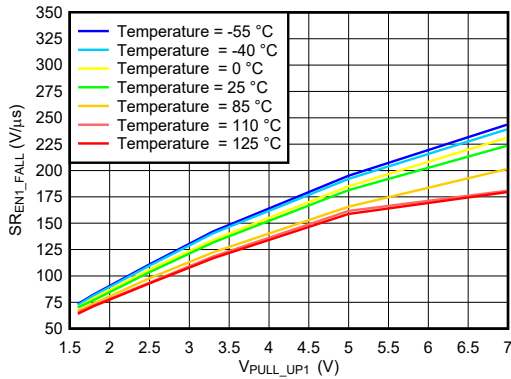

$V_{UP} = V_{DOWN} = \downarrow 0V$ $V_{IN} = 12V$
 $R_{REG_TMR} = \text{Floating}$

图 6-25. SR_{EN1_FALL} vs V_{PULL_UP1} Across Temperature

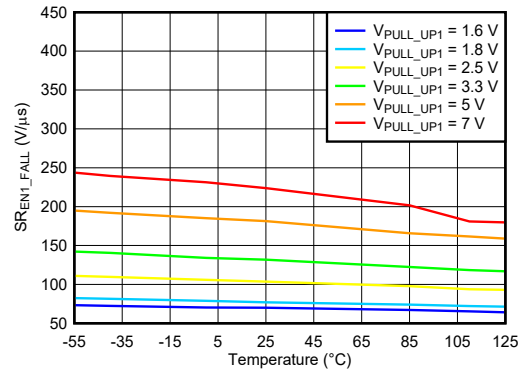

$V_{UP} = V_{DOWN} = \downarrow 0V$ $V_{IN} = 12V$
 $R_{REG_TMR} = \text{Floating}$

图 6-26. SR_{EN1_FALL} vs Temperature Across V_{PULL_UP1}

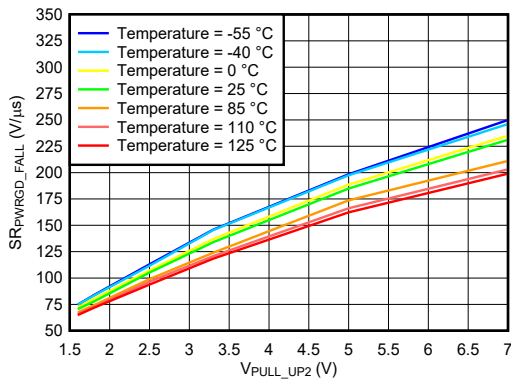

$V_{UP} = V_{DOWN} = \downarrow 0V$ $V_{IN} = 12V$
 $R_{REG_TMR} = \text{Floating}$

图 6-27. SR_{PWRGD_FALL} vs V_{PULL_UP2} Across Temperature

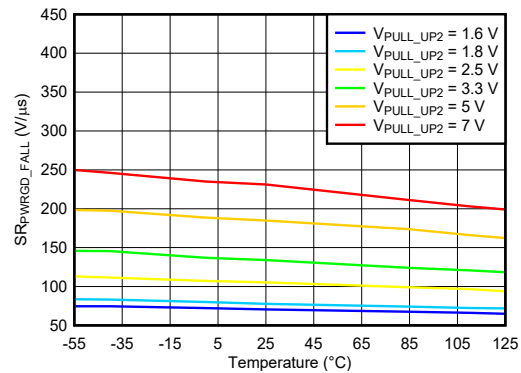

$V_{UP} = V_{DOWN} = \downarrow 0V$ $V_{IN} = 12V$
 $R_{REG_TMR} = \text{Floating}$

图 6-28. SR_{PWRGD_FALL} vs Temperature Across V_{PULL_UP2}

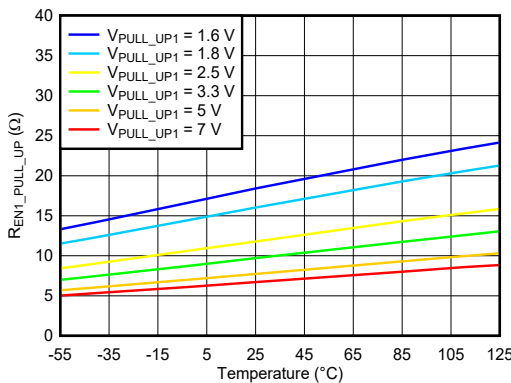

$V_{UP} = V_{DOWN} = 3.3V$ $V_{IN} = 12V$
 $R_{REG_TMR} = \text{Floating}$ $I_{LOAD} = 2mA$

图 6-29. $R_{EN1_PULL_UP}$ vs Temperature Across V_{PULL_UP1}

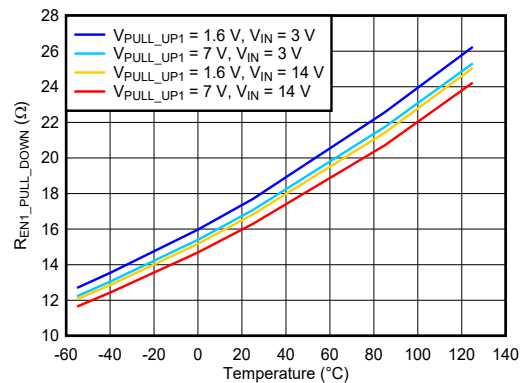

$V_{UP} = V_{DOWN} = 0V$ $V_{IN} = 12V$
 $R_{REG_TMR} = \text{Floating}$ $I_{LOAD} = -2mA$

图 6-30. $R_{EN1_PULL_DOWN}$ vs Temperature Across V_{PULL_UP1}

7 Parameter Measurement Information

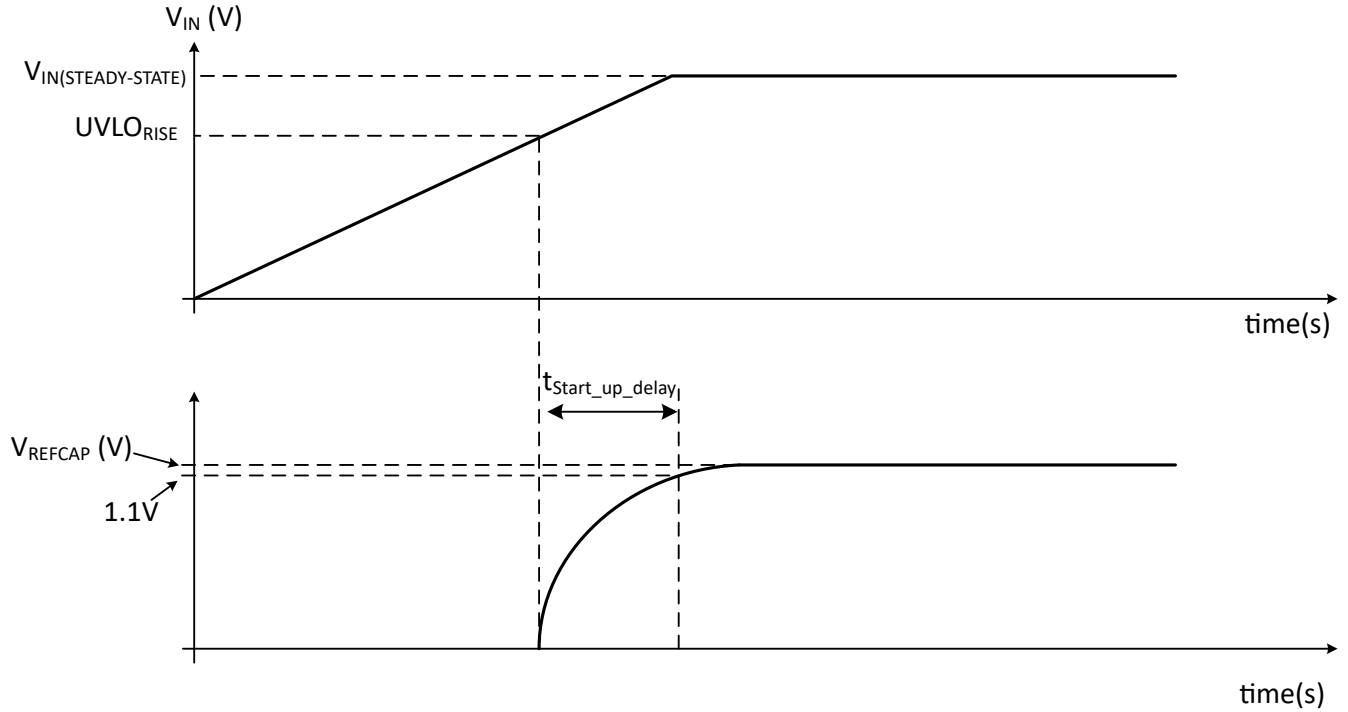

A. $V_{IN(STEADY-STATE)}$ is a valid operating voltage between 3V and 14V

图 7-1. $t_{start_up_delay}$ Time Measurement



图 7-2. ENx Propagation Delay (t_{pd_ENx}) Time Measurement - Rising Voltage



图 7-3. ENx Propagation Delay (t_{pd_ENx}) Time Measurement - Falling Voltage

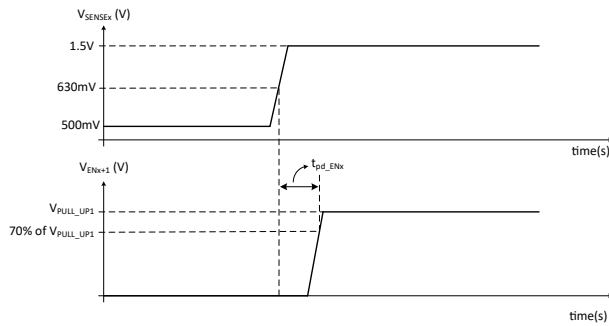

图 7-4. SEQ_DONE Propagation Delay ($t_{pd_SEQ_DONE}$) Time Measurement - Rising Voltage

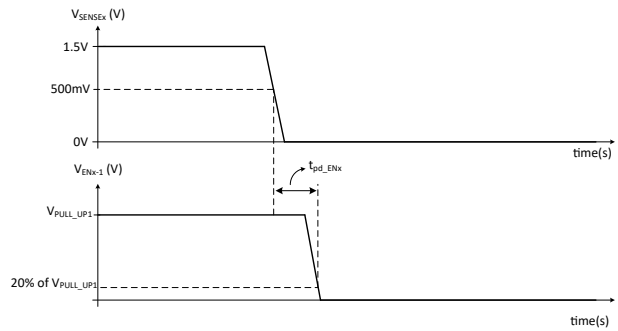

图 7-5. SEQ_DONE Propagation Delay ($t_{pd_SEQ_DONE}$) Time Measurement - Falling Voltage

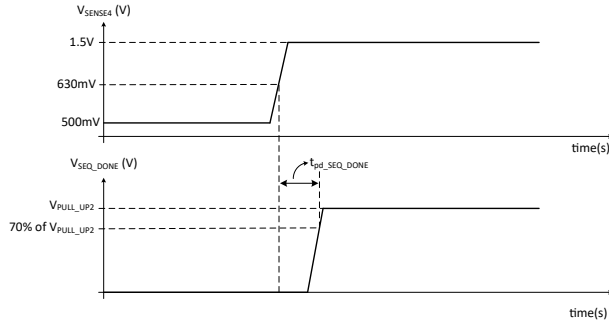

图 7-6. PWRGD Propagation Delay (t_{pd_PWRGD}) Time Measurement - Rising Voltage

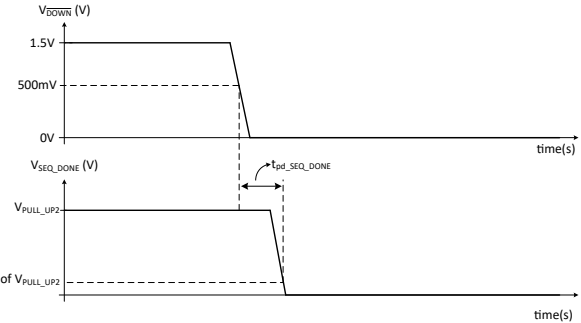

图 7-7. PWRGD Propagation Delay (t_{pd_PWRGD}) Time Measurement - Falling Voltage

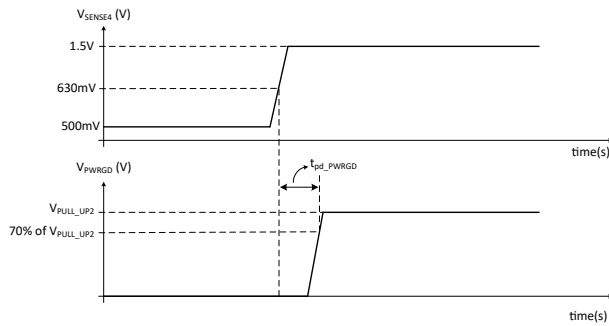

- A. V_{SENSE1} is pulled-low after the state machine is in the waiting to sequence down state.
- B. The slow rates are exaggerated for easier visualization.

图 7-8. State Machine Detected Fault Propagation Delay ($t_{pd_SM_FAULT}$)

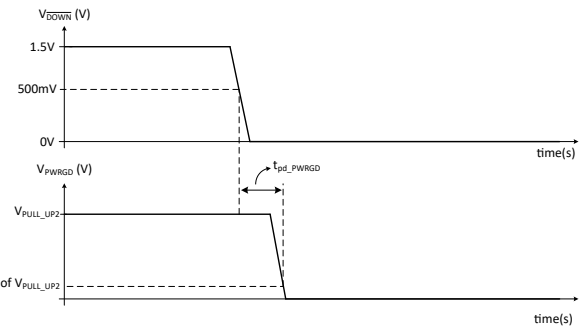
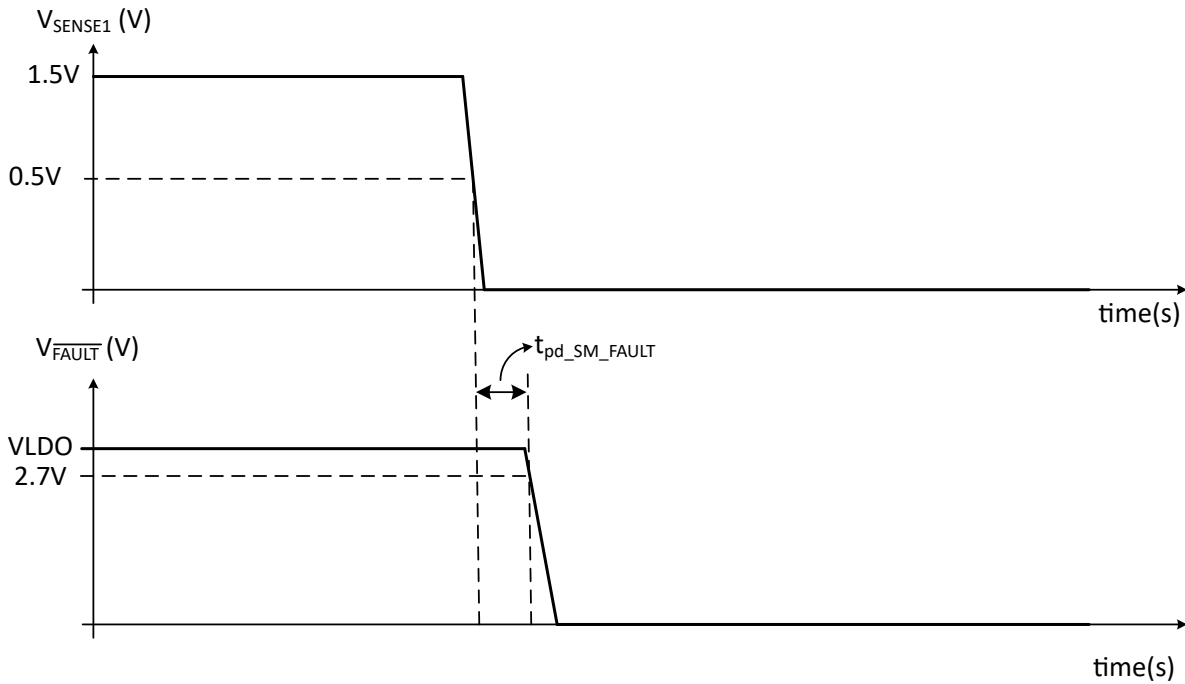

图 7-9. Minimum Time for Valid Sequence Up Command (t_{MIN_UP})



图 7-10. Minimum Time for Valid Sequence Down Command (t_{MIN_DOWN})

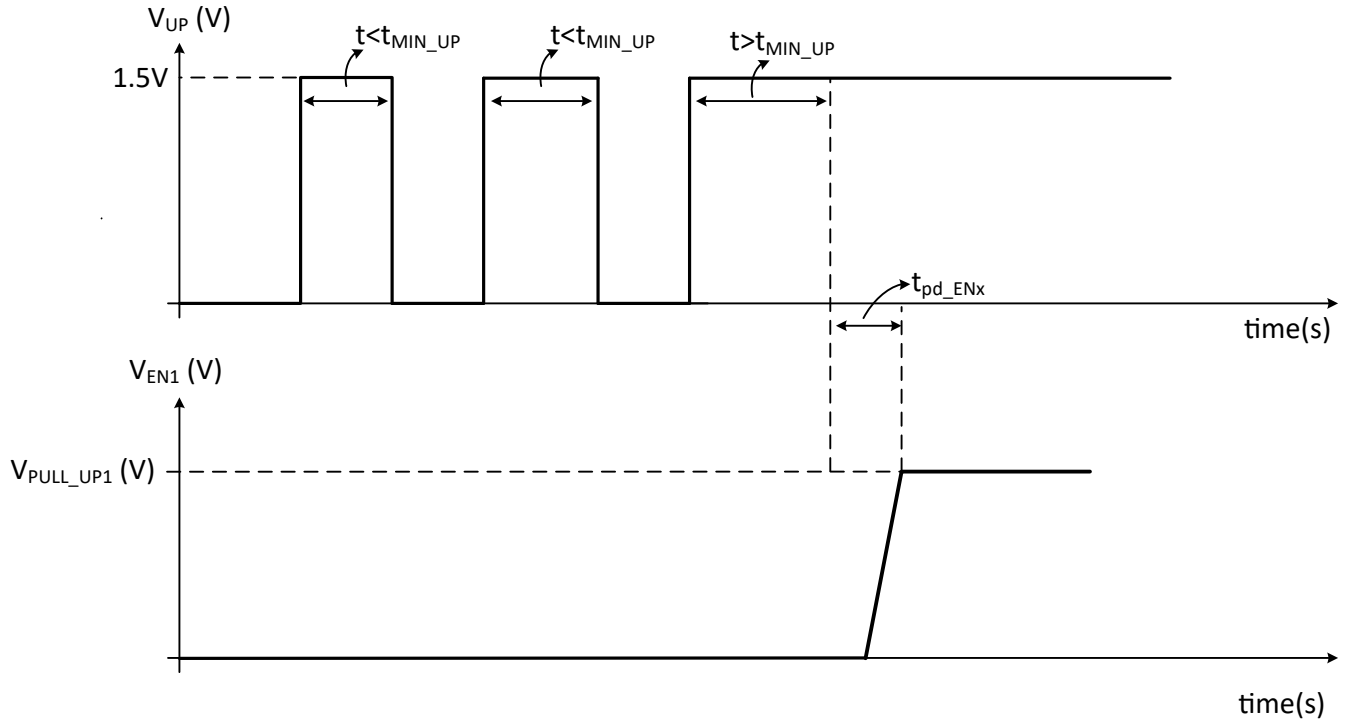

图 7-11. Rising Threshold on SENSEx Hold Time ($t_{h_VTH_RISE}$)

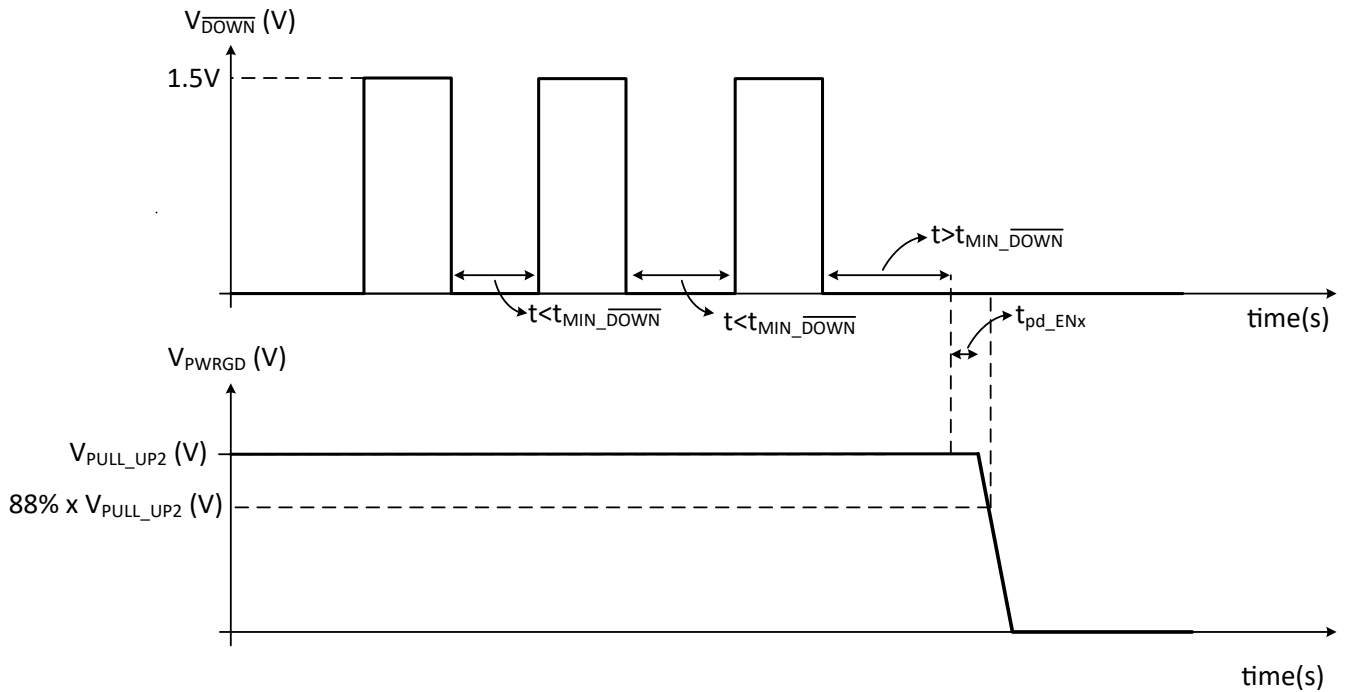

图 7-12. Falling Threshold on SENSEx Hold Time ($t_{h_VTH_FALL}$)

8 Detailed Description

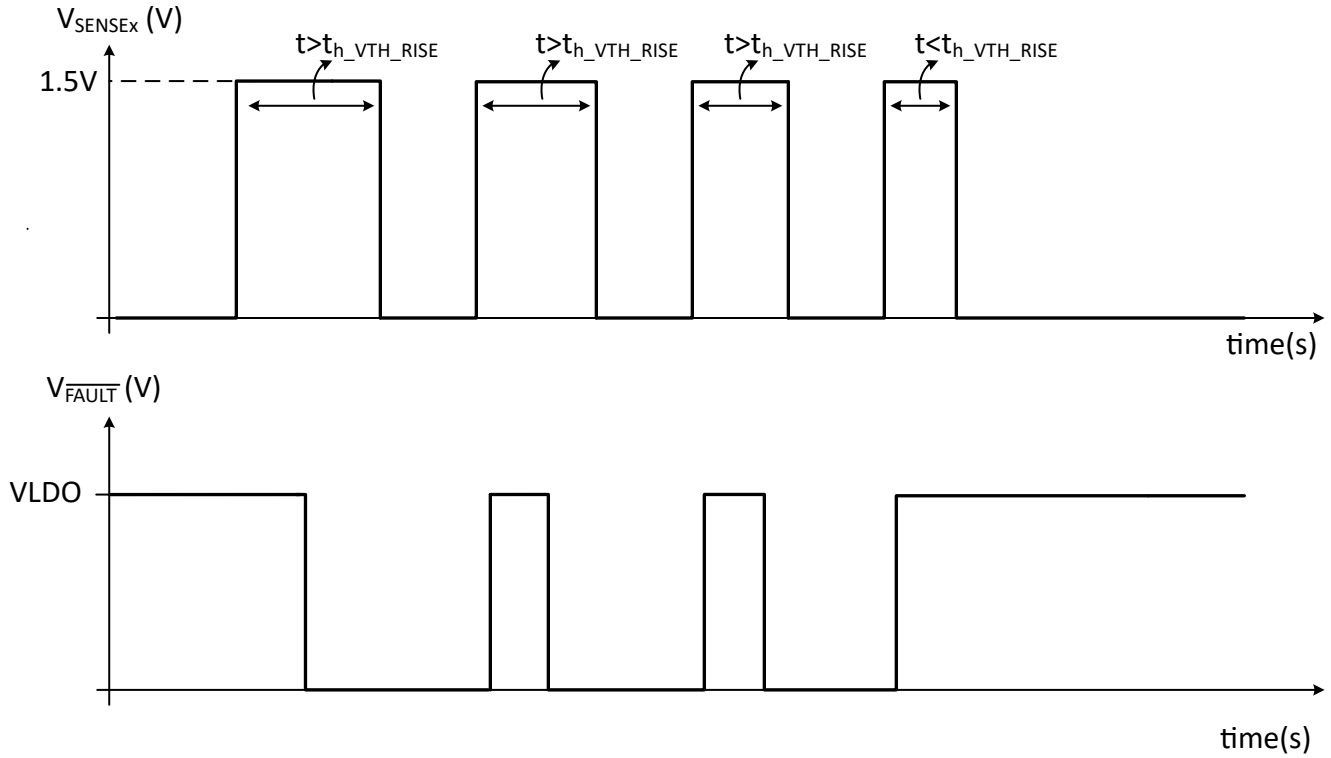
8.1 Overview

The TPS7H3014 is a four-Channel, 3V to 14V, sequencer and supervisor for space applications. The device is intended to drive devices with enable high logic inputs. The channel count can be incremented as needed for the application by connecting multiple ICs. in a daisy-chain configuration. Each output incorporates a push-pull architecture. The logic high of these outputs are externally provided by the user by supplying a voltage to the PULL_UPx inputs. All ENx push-pull outputs are tied to the PULL_UP1 domain while SEQ_DONE and PWRGD are tied to the PULL_UP2 domain.

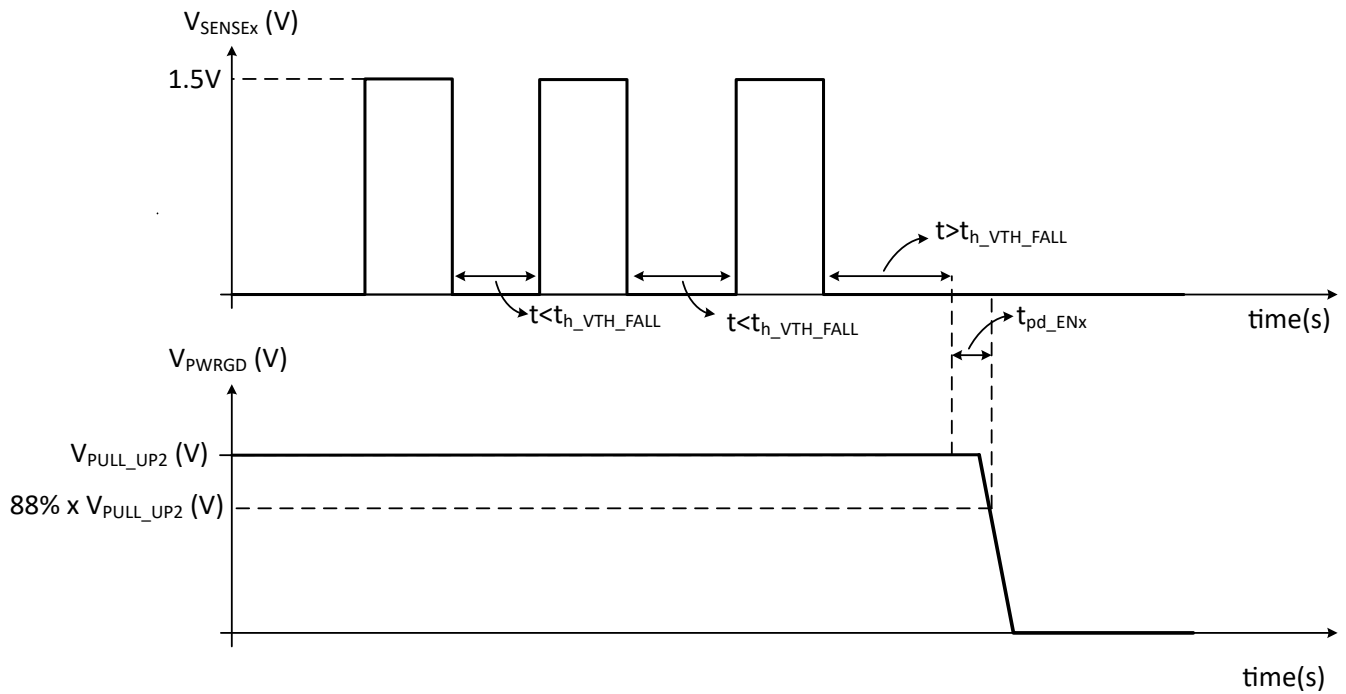
The SENSEx inputs are connected to the non-inverting input (undervoltage) of a comparator which is used to determine the on (in regulation) and off (not in regulation) voltage level of the monitored power supply (V_{OUTx}). Each of these inputs feature a threshold level of 599mV (typ) with an accuracy of $\pm 1\%$ across: voltage, temperature, and radiation (TID). The hysteresis voltage threshold level can be adjusted by the user and determined by the R_{TOPx} resistance and the hysteresis current (I_{HYS}). The I_{HYS} becomes active once the rising voltage at SENSEx exceeds the threshold (599mV typ), indicating the monitored voltage rail is in regulation. I_{HYS} is 24 μ A with an accuracy of $\pm 3\%$ across: voltage, temperature, and radiation (TID).

The device incorporates two timers:

1. **DLY_TMR**: Set the rising and falling ENx delay. Once the $SENSE_{x-1}$ is above the on voltage during a sequence up, the EN_x will be asserted high once the delay set by the user using the DLY_TMR input is expired. The same is true during sequence down, this means that once $SENSE_x$ is below the off voltage the EN_{x-1} will be asserted low once the timer is expired. This timer can be set from 0.25ms to 25ms, by using a 10.5k Ω to a 1.18M Ω , respectively.
2. **REG_TMR**: Set the allowed time that a sensed voltage rail has to be above the on threshold (in regulation). Once the EN_x is asserted high, the $SENSE_x$ has up to the time set by the user, using REG_TMR, to be above 599mV (typ). Otherwise a reverse sequence down from EN_{x-1} is started.

Separate UP and \overline{DOWN} pins are provided by the device in order to enable daisy-chain configurations. The UP pin has a threshold (V_{TH_UP}) of 599mV (typ), while the \overline{DOWN} pin has an threshold (V_{TH_DOWN}) of 498mV. A fixed hysteresis of 100mV is incorporated in both input comparators for noise stability. These pins are edge sensitive, a rising edge in UP starts the sequence up, while a falling edge in \overline{DOWN} will start the sequence down.

When using a single device and driven externally, both pins (UP and DOWN) are typically tied together. Since UP and \overline{DOWN} inputs have an accurate threshold, they can be used to initiate the sequence up and down by accurately sensing another rail (using a resistive divider), or they can be externally driven by a controller. Once UP is driven above V_{TH_UP} , the device will start a sequence up by asserting EN1 high after the programmed delay time (DLY_TMR), at which point the SENSE1 will start rising up. If SENSE1 crosses the on voltage before the REG_TMR is expired, then EN2 will be asserted high after the programmed delay. This process continues until the SEQ_DONE and PWRGD are asserted high indicating a complete sequence up and system power good, respectively.

Once the \overline{DOWN} pin is driven below V_{TH_DOWN} , the device will start a sequence down by forcing EN4 low after the programmed delay. At this point, the SENSE4 voltage will start falling until is lower than the set off voltage. Once this happens, EN3 will be asserted low after the programmed delay. This will continue until EN1 is forced low. As the discharge time of the sequenced devices is unknown, the REG_TMR is not active during power down.

During sequence up, SEQ_DONE and PWRGD are asserted high after the last used channel crosses the on voltage threshold and the programmed DLY_TMR is expired (assuming it is active). During sequence down, SEQ_DONE is forced low once V_{OUT1} is below the off voltage and the DLY_TMR is expired. However PWRGD is forced low immediately after the commanded sequence down.

The TPS7H3014 also incorporates a comprehensive FAULT management system described in the [State Machine](#) section.

8.2 Functional Block Diagram

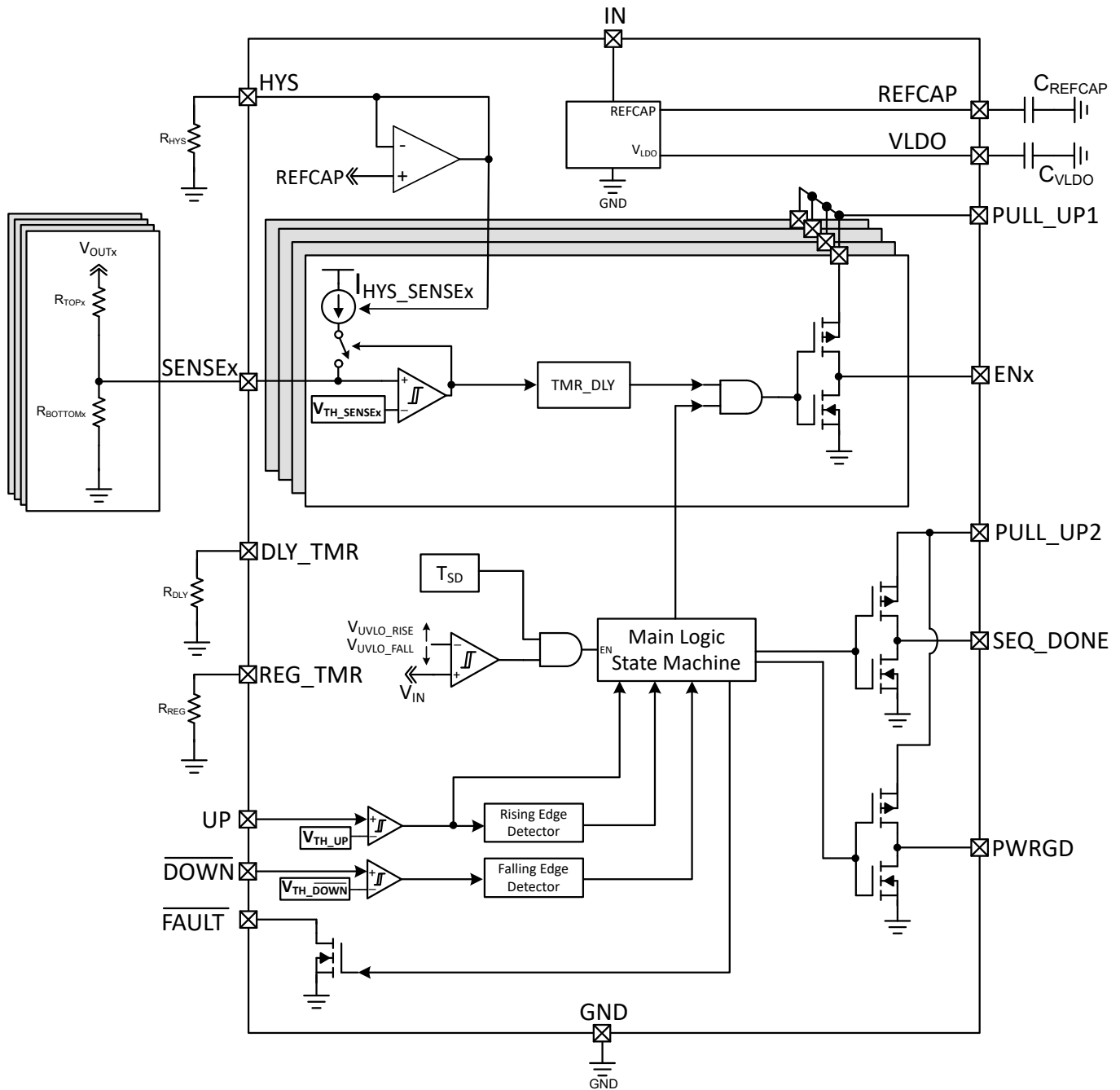

8.3 Feature Description

8.3.1 Input Voltage (V_{IN}), VLDO and REFCAP

During steady state operation, the input voltage of the TPS7H3014 must be between 3V and 14V. A minimum bypass capacitance of at least $0.1 \mu\text{F}$ is needed between V_{IN} and GND. The input bypass capacitors should be placed as close to the 序列发生器 IC as possible. It is recommended that V_{IN} slew rate is controlled between $10\text{V}/\mu\text{s}$ to $1\text{mV}/\mu\text{s}$ for proper IC operation.

The voltage applied at V_{IN} serves as the input for the internal regulator that generates the VLDO voltage, typically 3.29V. At input voltages less than the 3.29V (typ), the VLDO voltage will follow the voltage at V_{IN} . Recommended capacitance for VLDO is $1 \mu\text{F}$. Unused SENSE2 to SENSE4 can be tied to VLDO to by-pass the channel delay during sequence up and down. It is recommended to pull-up the FAULT pin to VLDO via a $10\text{k}\Omega$ resistor, but otherwise it is recommended not to externally load this pin due to limited output current capability. During power up, the user should wait at least the 2.8ms ($t_{\text{Start_up_delay}}$) after $V_{IN} > UVLO_{\text{RISE}}$ before attempting to start a sequence up, this is due to internal time constants in the device.

Each device generates an internal 1.2V bandgap reference that is utilized throughout the various internal control logic blocks. This is the voltage present on the REFCAP pin during steady state operation. This voltage is divided down to produce the reference for the comparator inputs SENSE_x (599mV typ), UP (598mV typ) and DOWN (498mV typ). The $V_{\text{TH_SENSE}_x}$ reference is measured at the EN_x outputs to account for offsets in the error amplifier and maintains regulation within $\pm 1\%$ across: voltage, temperature, and radiation TID (up to 100krad in Silicon). This tight reference tolerance allows the user to monitor voltage rails with high accuracy. A 470nF capacitor to GND is required at the REFCAP pin for proper electrical operation as well as to ensure robust SET performance of the device.

8.3.1.1 Undervoltage Lockout ($V_{\text{POR_IN}} < V_{IN} < UVLO$)

When the voltage on V_{IN} is less than the UVLO (2.79V typ) voltage, but greater than the power-on reset voltage ($V_{\text{POR_IN}}$, 1.41V typ), the output pins (EN_x, SEQ_DONE and PWRGD) will be in a logic low state, regardless of the voltage at the inputs of the device, named as:

- SENSE_x
- UP
- $\overline{\text{DOWN}}$

8.3.1.2 Power-On Reset ($V_{IN} < V_{\text{POR_IN}}$)

When the voltage on V_{IN} is lower than the power on reset voltage ($V_{\text{POR_IN}}$), the output signal is undefined and is not to be relied upon for proper device function.

图 8-1 shows the EN_x outputs relationship to a rising input voltage (V_{IN}). As can be observed, the EN_x are undefined when V_{IN} is lower than $V_{\text{POR_IN}}$ (typically 1.41V). During this time the outputs can be any value from 0V to V_{IN} . In this case, the input voltages to all undervoltage (UV) input comparators (SENSE_x) are below the $V_{\text{TH_SENSE}_x}$ (599mV). For this reason (in conjunction with waiting for a rising edge on UP), the EN_x, SEQ_DONE and PWRGD stays low after V_{IN} rises above $UVLO_{\text{RISE}}$ (typically 2.79V).



图 8-1. Outputs in a Valid Low State After $V_{IN} > V_{IN-MIN}$

A. This figure assumes:

1. A valid external pull-up voltage is connected to the PULL_UPx inputs ($1.6V \leq V_{PULL_UPx} \leq 7V$).
2. $V_{IN(STEADY-STATE)}$ is a valid V_{IN} voltage between 3V to 14V.
3. V_{FAULT} pull up to VLDO.
4. Device is in the: Waiting to Sequence UP State (Refer to [State Machine](#) for more details).
5. V_{OL} represents: V_{OL_ENx} , $V_{OL_SEQ_DONE}$, and V_{OL_PWRGD} , or the low logic output voltage for all outputs.

8.3.2 SENSE_x Inputs

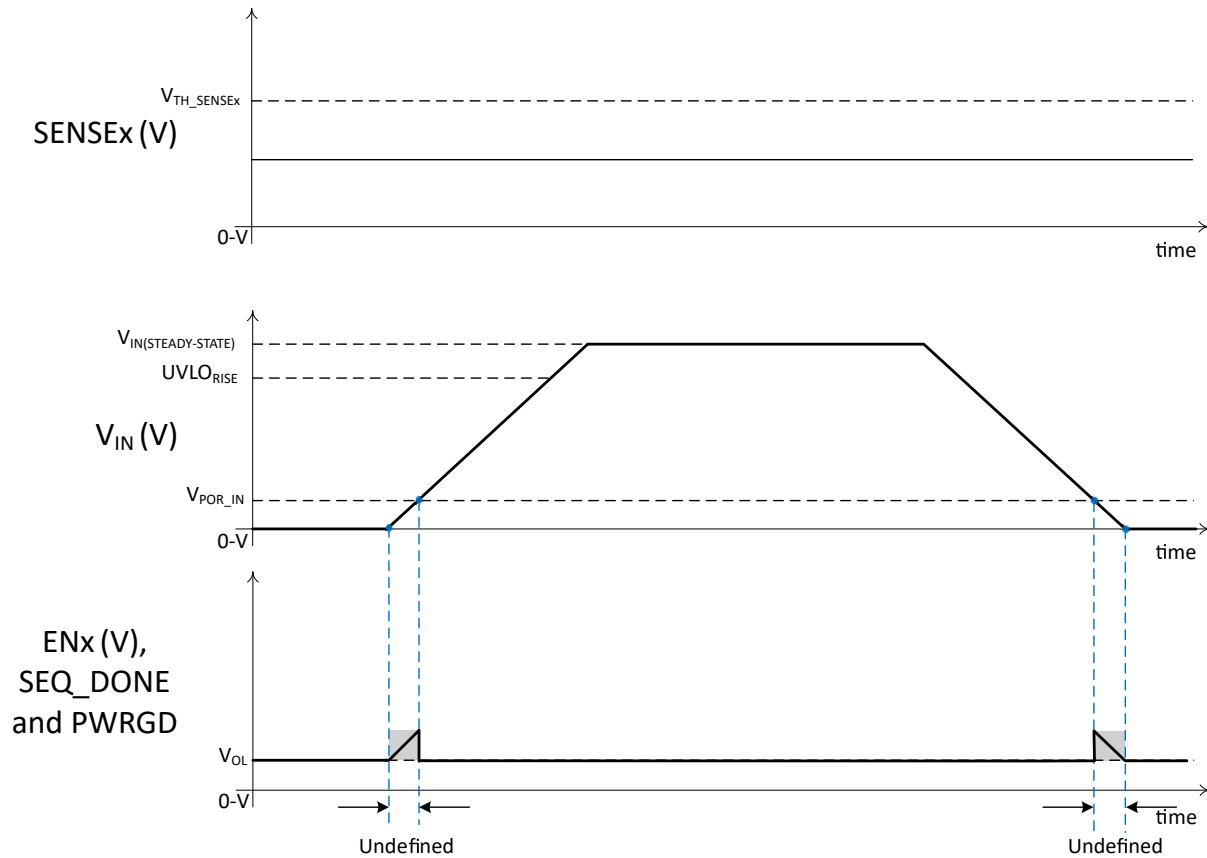
8.3.2.1 V_{TH_SENSE_x} and V_{ON_x}

The TPS7H3014 sequencer integrates four under-voltage (UV) comparators, with an accurate ($\pm 1\%$) threshold voltage (V_{TH_SENSEx}) of 599mV nominal. V_{TH_SENSEx} is measured at the EN_x outputs to account for comparator offsets in the threshold. Maximum flexibility is provided as external resistive dividers can be adjusted to sense any voltage rail (V_{OUTx}). 图 8-2 shows a conceptual diagram of the comparators connected to the SENSE_x inputs. As can be observed, the sensed voltage rail (V_{OUTx}) is attenuated (using an external resistive divider, R_{TOPx} and $R_{BOTTOMx}$) and compared against the V_{TH_SENSEx} voltage. Is recommended to maintain the steady-state SENSE_x voltage below 1.6V, in order to maintain the threshold (V_{TH_SENSEx}) accuracy.



图 8-2. SENSE_x Comparators Inputs

When the voltage at the monitored rail (V_{OUTx}) is rising, the hysteresis current (I_{HYS}) is not connected to SENSE_x input. At this time the SENSE_x (attenuated V_{OUTx}) voltage is compared against the SENSE_x threshold (V_{TH_SENSEx}). When $V_{SENSEx} > V_{TH_SENSEx}$ the voltage is considered within regulation limits. We can calculate the on (within regulation) voltage by doing a simple voltage divider as:

$$V_{ONx_NOMINAL} (V) = \left(1 + \frac{R_{TOPx}}{R_{BOTTOMx}}\right) \times V_{TH_SENSEx} \quad (1)$$

Where:

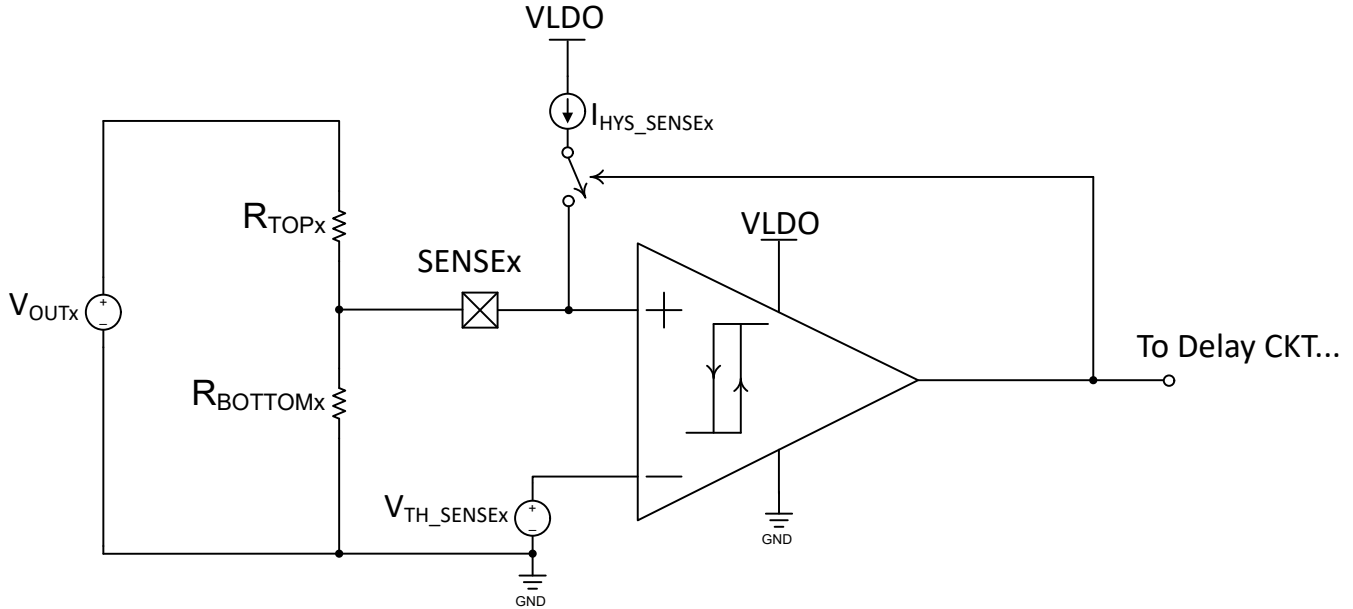
- V_{TH_SENSEx} is the nominal sense threshold voltage of 599mV.

As with any system, there is some variation (or errors) of the design variables, in this case the top and bottom resistors and the SENSE_x threshold voltage. Using the derivative method to calculate the total error (and assuming these variables are uncorrelated) with both resistors having the same tolerance value, the V_{ONx} error can be calculated as:

$$V_{ONx_ERROR} (V) = \pm \sqrt{\frac{V_{TH_SENSEx}^2 \times \left[(2 \times R_{TOL}^2 \times R_{TOPx}^2) + (V_{TH_SENSEx_ACC}^2 \times (R_{TOPx} + R_{BOTTOMx})^2) \right]}{R_{BOTTOMx}^2}} \quad (2)$$

Where:

- R_{TOL} is the resistors tolerance (same for top and bottom resistors) as numeric value. For example, for 0.1% tolerance resistors, we use 0.001.
- $V_{TH_SENSEX_ACC}$ is the SENSEx threshold accuracy as numeric value (in this case 0.01).
- R_{TOPx} and $R_{BOTTOMx}$ are in Ohms (Ω).
- V_{TH_SENSEX} is 0.599 Volts.

Using [方程式 1](#) and [方程式 2](#) we can calculate the on voltage range as:

$$V_{ONx} = V_{ONx_NOMINAL} \pm V_{ONx_ERROR} \quad (3)$$

备注

Remember V_{TH_SENSEX} is the reference voltage when accounting for the comparator offsets
 $V_{TH_SENSEX} = V_{REF} + V_{OFFSETx}$.

As this device is intended for sequencing of multirail systems, the ENx to SENSEx order is defined in ascending channel number (EN1 to EN4) for sequence up, and descending (EN4 to EN1) for sequence down. When a channel of the sequencer is not needed (unused) the channel can be connected to VLDO to skip the channel during sequence up/down. Is recommended to connect all disabled channels to VLDO, but an external voltage greater than 91% of VLDO (max) will disabled the channel (the voltage at SENSEx cannot exceed 3.5V). Only channels 2 through 4 can be disabled. It is recommended to disabled channels starting from high (channel #4) to low (channel #2). The channels are disabled starting from the lowest channel count and higher. This means that if channel #2 is disabled, by definition channels #3 and #4 will also be disabled.

备注

The channels to be disabled must be valid at power up and not be dynamically changed during the sequence up and down.

Any voltage at SENSE 2 to SENSE4 > V_{TURN_OFF} [91% of VLDO(max)] will disable (or turn-off) the channel. This will disable the delay (set by TMR_DLY) for those channels during sequence up and down.

Although it is not required, in noisy applications it is good analog design practice to place a small bypass capacitor at the SENSEx inputs in order to reduce sensitivity to transient voltages on the monitored signal.

8.3.2.2 I_{HYS_SENSEX} and V_{OFFx}

The TPS7H3014 has a built-in hysteresis current of 24 μ A with an accuracy of $\pm 3\%$ (with $R_{HYS} = 50k\Omega$). The hysteresis current is equivalent to $REFCAP/R_{HYS}$. A tolerance of 0.1% for the R_{HYS} is recommended as it ultimately affects the hysteresis current accuracy.

备注

A resistor of $R_{HYS}=49.9k\Omega$ can be used instead of 50k Ω . In this case the nominal I_{HYS_SENSEX} current will be 24.05 μ A instead of 24 μ A.

This current is mirrored internally across all SENSEx inputs. This hysteresis current becomes active when the SENSEx voltage is greater than the threshold voltage (599mV $\pm 1\%$), same as $V_{OUTx} > V_{ONx}$ (Refer to [方程式 3](#) and [图 8-2](#)). This current (I_{HYS}) multiplied by the R_{TOPx} resistance induces a voltage (V_{HYSx}) that is added to the SENSEx node, effectively boosting (incrementing) the node voltage. During sequence down, or an undervoltage event when the V_{OUTx} is decrementing, it will need to drop below the V_{OFF} voltage in order to be considered as an out of regulation (or fault). The hysteresis voltage is defined as:

$$V_{HYSx_NOMINAL} (V) = I_{HYS_SENSEX} \times R_{TOPx} \quad (4)$$

Where:

- $I_{HYS_SENSEx} = 24 \times 10^{-6}$ Amps (or 24 μ A)
- R_{TOPx} units are in Ohms (Ω)

The "off" voltage (or out of regulation) voltage can be calculated as:

$$V_{OFFx_NOMINAL} (V) = V_{ONx_NOMINAL} - V_{HYSx_NOMINAL} \quad (5)$$

Using [方程式 1](#) and [方程式 5](#)

$$V_{OFFx_NOMINAL} (V) = \left[\left(1 + \frac{R_{TOPx}}{R_{BOTTOMx}} \right) \times V_{TH_SENSEx} \right] - (I_{HYS_SENSEx} \times R_{TOPx}) \quad (6)$$

Where:

- V_{TH_SENSEx} is the nominal sense threshold voltage of 0.599V
- $I_{HYS_SENSEx} = 24 \times 10^{-6}$ Amps (or 24 μ A)
- R_{TOPx} and $R_{BOTTOMx}$ units are in Ohms (Ω)

The V_{OFF} error (using the derivative method and assuming all variables are uncorrelated) can be calculated as:

$$V_{OFFx_ERROR} (V) = \pm \sqrt{\frac{A+B+C+D}{R_{BOTTOMx}^2}} \quad (7)$$

Where the equation terms are:

$$A = I_{HYS_SENSEx}^2 \times I_{HYS_SENSEx_ACC}^2 \times R_{TOPx}^2 \times R_{BOTTOMx}^2 \quad (8)$$

$$B = R_{TOL}^2 \times R_{TOPx}^2 \times V_{TH_SENSEx}^2 \quad (9)$$

$$C = R_{TOL}^2 \times R_{TOPx}^2 \times [(I_{HYS_SENSEx} \times R_{BOTTOMx}) - V_{TH_SENSEx}]^2 \quad (10)$$

$$D = V_{TH_SENSEx}^2 \times V_{TH_SENSEx_ACC}^2 \times (R_{TOPx} + R_{BOTTOMx})^2 \quad (11)$$

Where:

- R_{TOL} is the resistors tolerance (same for top and bottom resistors) as numeric value. For example, for 0.1% tolerance resistors, we use 0.001.
- $V_{TH_SENSEx_ACC}$ is the SENSEx threshold accuracy as numeric value (in this case 0.01).
- $I_{HYS_SENSEx_ACC}$ is the hysteresis current accuracy as numeric value (in this case 0.03)
- V_{TH_SENSEx} is the nominal sense threshold voltage of 0.599V
- $I_{HYS_SENSEx} = 24 \times 10^{-6}$ Amps (or 24 μ A)
- R_{TOPx} and $R_{BOTTOMx}$ units are in Ohms (Ω)

$$V_{OFFx} = V_{OFFx_NOMINAL} \pm V_{OFFx_ERROR} \quad (12)$$

Using [方程式 6](#) and [方程式 7](#) we can calculate the off voltage range as:

[图 8-3](#), shows a conceptual diagram of the rising and falling voltage, it also shows the errors on this voltage due to V_{TH} accuracy, I_{HYS} accuracy, and the resistive divider tolerances. At the system level, these errors have to be taken into account for a robust design.



图 8-3. Rising and Falling Thresholds Voltages for the SENSE_x Comparators

8.3.2.3 Top and Bottom Resistive Divider Design Equations

At the system level the designer knows (or selects) the V_{ONx} and V_{OFFx} levels. Usually these voltages are selected as percentages of the nominal rail voltage (V_{OUTx}) being monitored. Knowing this information, we can calculate the resistive divider components values (R_{TOPx} and $R_{BOTTOMx}$) for the desired target levels. Using [方程式 4](#) and [方程式 5](#) we can calculate the top resistor as:

$$R_{TOPx} = \frac{V_{ONx} - V_{OFFx}}{I_{HYS_SENSEx}} \quad (13)$$

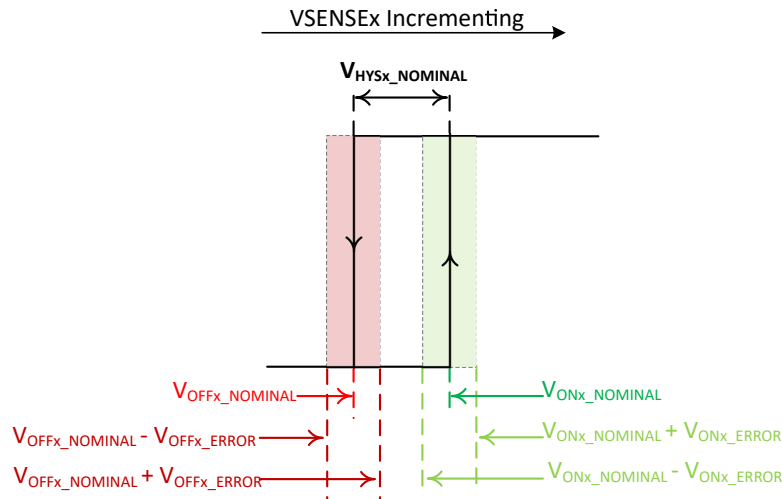
From [方程式 1](#) we can calculate the bottom resistor as:

$$R_{BOTTOMx} = \frac{R_{TOPx} \times V_{TH_SENSEx}}{V_{ONx} - V_{TH_SENSEx}} \quad (14)$$

It's important to notice that the larger the separation between V_{ONx} and V_{OFFx} (referred as V_{HYSx}), the bigger the error in the off voltage. [图 8-4](#) shows a plot of the error in the V_{OFFx} for different hysteresis voltages ($V_{HYSx} = V_{ONx} - V_{OFFx}$). The plot is created for three different V_{ON} voltages (or percentages of the nominal output voltage: 90, 95, and 97%) and two different output voltages (0.8V and 28V). As can be observed, the output voltage has very little impact on the off voltage error (differences cannot be appreciated on the plot). The error (in percent) can go from approximately 1% (at $V_{HYS} = 3\%$) to around 2.6% (at $V_{HYS} = 80\%$).



图 8-4. V_{OFFx} Error vs V_{HYS}

- A. This plot does not includes the error on the V_{OFFx} due to the difference between the calculated top and bottom resistors using [方程式 13](#) and [方程式 14](#) and the actual resistance values that a designer can procure.
- B. The resistor tolerance used for the calculation is 0.1%, V_{TH_SENSEx} accuracy is 1%, and the I_{HYS_SENSEx} accuracy is 3%.
- C. In this plot the V_{HYS} (%) represents the separation as percentages of the nominal output voltage (V_{OUTx}).
- D. In this plot, the V_{OFF} error in % is normalized with respect to the full-scale voltage (or V_{OUTx}).

8.3.3 Output Stages (ENx, SEQ_DONE, PWRGD, PULL_UP1 and PULL_UP2)

The output stage's (EN1 to EN4), SEQ_DONE and PWRGD are of push-pull, active high type. The pull-up voltage for the push-pull outputs is externally provided by the user. PULL_UP1 (input) is the pull-up voltage domain for all ENx outputs (EN1 to EN4), while PULL_UP2 (input) is the pull-up voltage domain for the SEQ_DONE and PWRGD outputs.

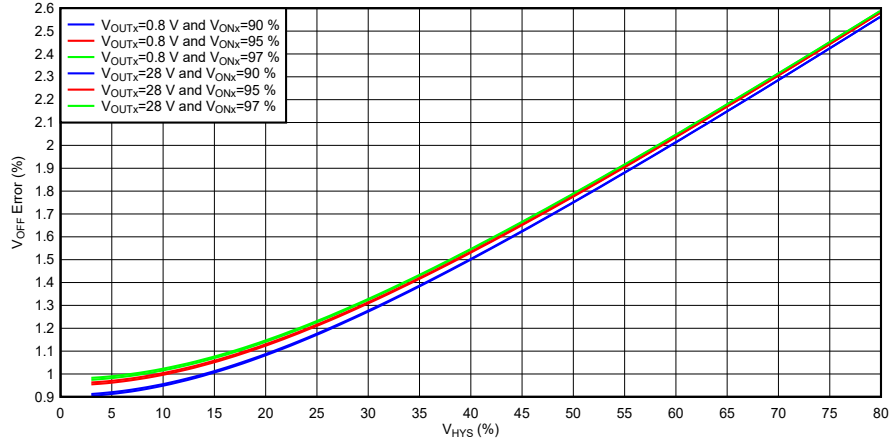
备注

There are no sequencing requirements for IN, PULL_UP1, and PULL_UP2; however, all must be biased before commanding a sequence up and down.

备注

TI recommends to decouple PULL_UPx inputs with a 1 μ F ceramic capacitor as close to the pins as possible. This is to ensure clean voltages signals at the outputs (ENx, PWRGD, and SEQ_DONE).

Each output stage consists of a PMOS/NMOS (CMOS) pair. Each leg has an output resistance of typically 7 Ω for $V_{PULL_UPx} > 3.3V$. PULL_UP1 and PULL_UP2, have a voltage range of 1.6V 至 7V, and can be independently biased or tied to the same voltage rail, however both must be biased. The output resistance of the PMOS leg has a PULL_UPx voltage dependency. The lower the PULL_UPx voltage, the higher the PMOS resistance.

When $V_{IN} < V_{POR_IN}$ and $V_{PULL_UPx} > V_{POR_PULL_UPx}$ (1.4V maximum) the output will be in a known pull-down state. At this condition the outputs have reduced sinking capabilities with $V_{OL} \leq 320mV$ when the device is sinking 100 μ A of current into the outputs:

- ENx
- PWRGD
- SEQ_DONE

Once the input voltage range is within the recommended input voltage range of 3V to 14V, the output will have the full strength capabilities of $\pm 10mA$, per output.



图 8-5. ENx Push-Pull Output Stages



图 8-6. SEQ_DONE Push-Pull Output Stage

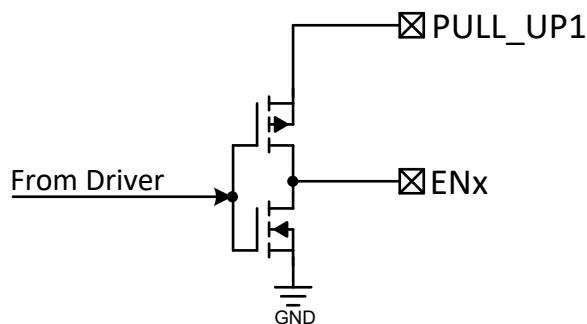

图 8-7. PWRGD Push-Pull Output Stage

8.3.4 User-Programmable TIMERS

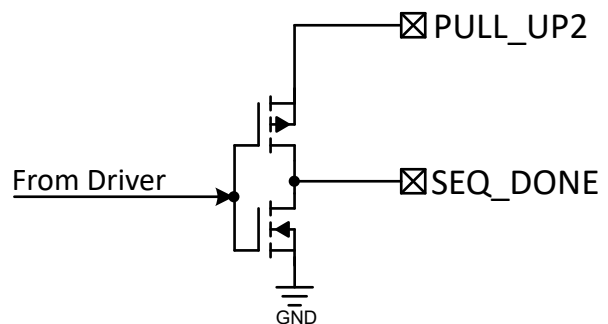
The TPS7H3014 has two global (or common to all SENSEx channels) adjustable timers:

- DLY_TMR
- REG_TMR

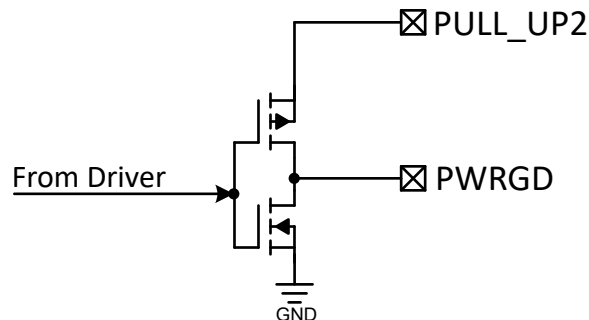
Both timers are programmed via a single resistor from the DLY_TMR and REG_TMR pin to GND. The resistors are used to program the internal oscillator frequency of the timers. Leaving the DLY_TMR or the REG_TMR pin floating will disable the timer, respectively. Disabling the timers results in a reduced current consumption on the device (I_{Q_IN}). The range for both timers is 250 μ s to 25ms.

备注

Timers conditions must be valid at power up and must not be dynamically changed.

图 8-8 shows a sequence up and down assuming no faults and UP/DOWN pins tied together. The DLY_TMR is shown in orange and the REG_TMR time is shown with arrows (starting from ENx going high).



图 8-8. Sequence UP and DOWN

- It's important to notice the t_{pd_ENx} , t_{pd_PWRGD} , and $t_{pd_SEQ_DONE}$ in blue. This is a propagation delay in the outputs (ENx,PWRGD and SEQ_DONE). If no DLY_TMR (floating) is used, the output signals will change to the valid state after this delay. When using the DLY_TMR, then this time has to be added to the programmed timer time.
- The REG_TMR is only valid during sequence up.

8.3.4.1 DLY_TMR

The TPS7H3014 includes an adjustable time delay. A single resistor connected between the DLY_TMR pin and GND will program the delay. Possible resistor (R_{DLY}) values are between $10.5k\Omega$ and $1.18M\Omega$ for a $268\mu s$ to $23.63ms$ delay, respectively. During sequence up, this delay holds the EN_{x+1} , SEQ_DONE, and PWRGD low after the monitored voltage crosses the "on" voltage ($V_{OUTx} > V_{ONx}$) for the user programmed time. During sequence down, the EN_{x-1} and SEQ_DONE are held high for the programmed delay time after the monitored voltage crosses the "off" voltage ($V_{OUTx} < V_{OFFx}$).

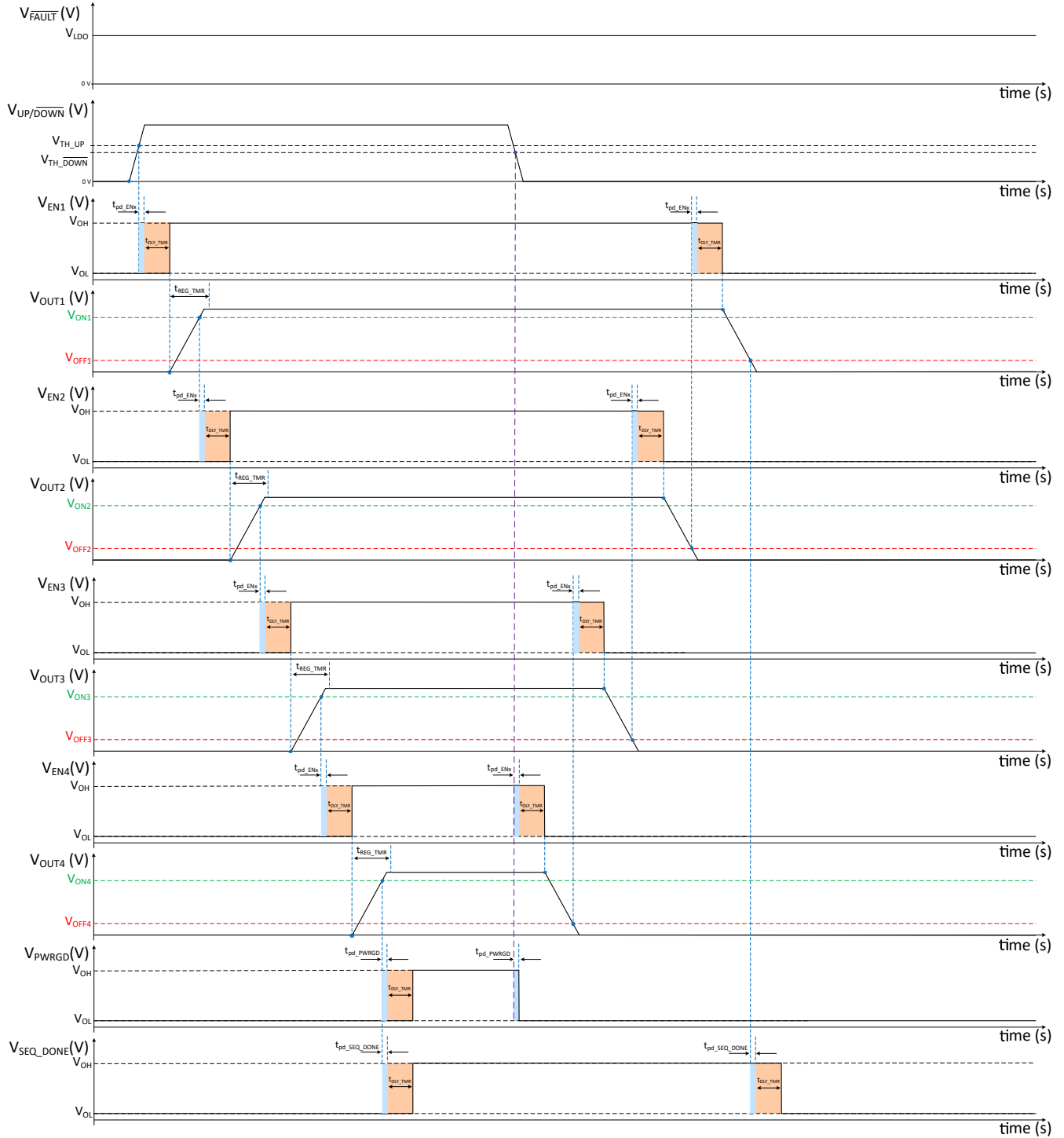
备注

During sequence down, PWRGD goes low immediately after the $V_{DOWN} < V_{TH_DOWN}$.

If no delay is preferred for the system, the pin (DLY_TMR) can be left floating. When no delay is preferred, an inherent propagation delay of $6.5\mu s$ (max) will be observed during sequence up, between V_{OUTx} crossing the V_{ONx} and EN_{x+1} going high. The propagation delay is also observed during sequence down when V_{OUTx} cross the V_{OFFx} and the EN_{x-1} is forced low. SEQ_DONE and PWRGD also have this propagation delay during $V_{OUT4} > V_{ON4}$ during sequence up. During sequence down, SEQ_DONE will go low after the propagation delay when $V_{OUT1} < V_{OFF1}$ and PWRGD will go low after the propagation delay when the sequence down is commanded. 图 8-8 shows the propagation delay in blue (t_{pd_ENx} , $t_{pd_SEQ_DONE}$, t_{pd_PWRGD}) and the programmed delay (t_{DLY_TMR}) in orange. The DLY_TMR resistor can be selected using 方程式 15 or 方程式 16. 图 8-9 and 图 8-10 shows the linear trend between the DLY_TMR resistor and the delay time.

For t_{DLY_TMR} between $0.268ms$ and $12.5ms$ use:

$$R_{DLY_TMR}(k\Omega) = [49.75 \times t_{DLY_TMR}(ms)] - 2.832 \quad (15)$$

For t_{DLY_TMR} greater than $12.5ms$ use:

$$R_{DLY_TMR}(k\Omega) = [51.61 \times t_{DLY_TMR}(ms)] - 26.12 \quad (16)$$

表 8-1 shows nominal resistors value for different delay times.

表 8-1. Typical DLY_TMR Resistors

t_{DLY_TMR} (ms)	R_{DLY_TMR} (k Ω)
0.268	10.5
12.5	619
23.37	1180



图 8-9. R_{DLY_TMR} vs t_{DLY_TMR} From $0.268ms$ to $12.5ms$



图 8-10. R_{DLY_TMR} vs t_{DLY_TMR} From $12.5ms$ to $23.37ms$

8.3.4.2 REG_TMR

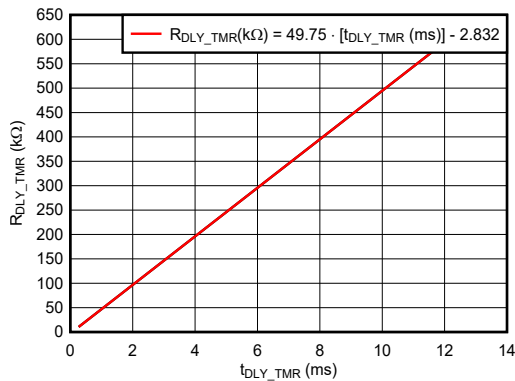
The REG_TMR (for regulation timer) is an adjustable time monitor that monitors the time it takes to $V_{OUTx} > V_{ONx}$. The user can program the REG_TMR using a single resistor between REG_TMR and GND. The range of the resistor (R_{REG}) is between $10.5k\Omega$ to $1.18M\Omega$, for a $264\mu s$ to $23.63ms$, respectively. If the user does not want the REG_TMR to be active, the pin can be left floating. In this case, V_{OUTx} has infinite time to cross the V_{ONx} voltage. The REG_TMR is only active during the sequence up.

备注

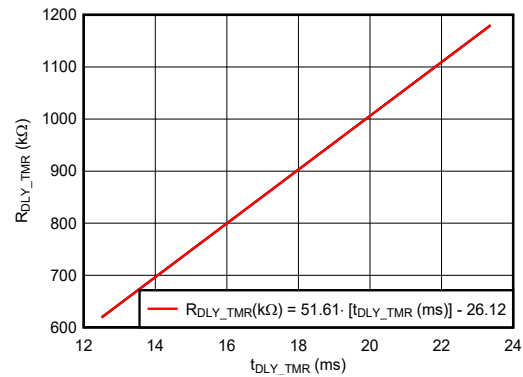
If the REG_TMR is left floating and the V_{ONx} voltage is never crossed, the state machine will stay waiting indefinitely.

If active, the REG_TMR will monitor the time a V_{OUTx} takes to cross the V_{ONx} voltage once the ENx signal is forced high. In the case the REG_TMR is expired and V_{OUTx} has not crossed the V_{ONx} voltage, a reverse sequence down from the previously sequenced rail will be started as described in the [State Machine](#) section. [图 8-8](#) shows the REG_TMR active during sequence up, from the time ENx is forced high (V_{OUTx} starts rising). In this case, V_{OUTx} always crosses V_{ON} before the timer is expired. The REG_TMR resistor can be selected using [方程式 17](#) and [方程式 18](#). [图 8-11](#) or [图 8-12](#) shows the linear trend between the REG_TMR resistor and the regulation time allowed for the rail to be in regulation ($V_{OUTx} > V_{ONx}$).

For t_{DLY_TMR} between $0.264ms$ and $12.4ms$ use:

$$R_{DLY_TMR}(k\Omega) = [50.14 \times t_{DLY_TMR}(ms)] - 2.737 \quad (17)$$

For t_{DLY_TMR} greater than $12.4ms$ use:

$$R_{DLY_TMR}(k\Omega) = [49.96 \times t_{DLY_TMR}(ms)] - 0.4479 \quad (18)$$

[表 8-2](#) shows typical resistor values for different allowed regulation times.

表 8-2. Typical REG_TMR Resistors

t_{REG_TMR} (ms)	R_{REG_TMR} (k Ω)
0.264	10.5
12.4	619
23.63	1180



图 8-11. R_{REG_TMR} vs t_{REG_TMR} From 0.264ms to 12.4ms



图 8-12. R_{REG_TMR} vs t_{REG_TMR} From 12.4ms to 23.63ms

8.3.5 UP and $\overline{\text{DOWN}}$

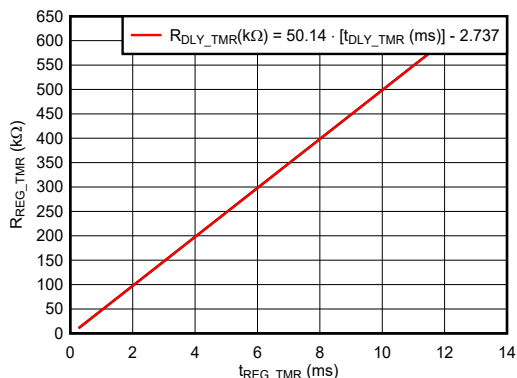
The UP and $\overline{\text{DOWN}}$ pins are the inputs that initiate a sequence up or down. Both pins incorporate an accurate comparator with a threshold voltage of $V_{\text{TH_UP}} = 599\text{mV}$ (for UP) and $V_{\text{TH_DOWN}} = 498\text{mV}$ (for $\overline{\text{DOWN}}$) with an accuracy of $\pm 3\%$ for both inputs.

A fixed hysteresis of 100mV is incorporated in both comparators for noise stability. The edges on these pins are used to initiate the command as:

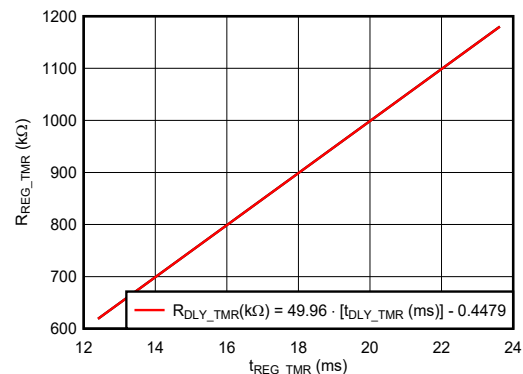
- Rising edge on UP starts a sequence up.
- Falling edge on $\overline{\text{DOWN}}$ starts a sequence down.

The UP voltage is also used in the state machine as a latch method to prevent oscillations during a FAULT. In order to move away from the Fault state, the UP voltage has to be logic low. As UP is a comparator with 100mV of hysteresis, depending on whether the V_{UP} have been previously above the $V_{\text{TH_UP}}$, the logic low level is:

- $V_{\text{TH_UP}} \leq 599\text{mV}$ (typ) if UP has not previously been above $V_{\text{TH_UP}}$.
- $V_{\text{UP_TH}}$ (typically 600mV) - 100mV $\leq 500\text{mV}$ (typ) if UP has previously crossed $V_{\text{UP_TH}}$.

These inputs can be driven externally by a house-keeping controller or via a resistive divider connected to a voltage source.

As these inputs are edge sensitive, is important to have a stable input voltage ($UVLO_{\text{RISE}} < V_{\text{IN}} < 14\text{V}$) for at least 2.8ms ($t_{\text{Start_up_delay}}$) before sending the sequence up command. This is due to internal time constants in the device. During sequence down, it's important to maintain a stable input voltage until the SEQ_DONE flag is set low to allow all rails to be properly sequenced down.

As both the UP and $\overline{\text{DOWN}}$ pins have accurate undervoltage comparators, the user can program the voltage at which the system will automatically start the sequence up and down when monitoring a main power rail (V_{MAIN}) via a resistive divider. However, in this case it is important to make sure the rising and falling edge are sent when V_{IN} is stable, as mentioned before. A capacitor can be added from UP to GND to delay the signal when the slew rate at V_{MAIN} is fast.

Usually the designer knows the voltages at which it's desired to start the sequence up (referred to as $V_{\text{UP_IDEAL}}$) and down (referred to as $V_{\text{DOWN_IDEAL}}$). With that information we can calculate the resistive divider values using [方程式 19](#) and [方程式 20](#). Usually the top resistor is fixed to a 10k Ω value.

$$R_{\text{BOTTOM_UP}} = R_{\text{TOP_UP}} \times \frac{V_{\text{TH_UP}}}{V_{\text{UP_IDEAL}} - V_{\text{TH_UP}}} \quad (19)$$

$$R_{\text{BOTTOM_DOWN}} = R_{\text{TOP_DOWN}} \times \frac{V_{\text{TH_DOWN}}}{V_{\text{DOWN_IDEAL}} - V_{\text{TH_DOWN}}} \quad (20)$$

where:

- $V_{\text{TH_UP}} = 598\text{mV}$ (typical)
- $V_{\text{TH_DOWN}} = 498\text{mV}$ (typical)

Once the designer knows the actual (real) resistive divider values, [方程式 21](#) and [方程式 22](#) can be used to calculate the sequence up and down nominal voltages as:

$$V_{\text{UP_NOMINAL}} \text{ (V)} = \left(1 + \frac{R_{\text{TOP_UP}}}{R_{\text{BOTTOM_UP}}} \right) \times V_{\text{TH_UP}} \quad (21)$$

$$V_{\text{DOWN_NOMINAL}} \text{ (V)} = \left(1 + \frac{R_{\text{TOP_DOWN}}}{R_{\text{BOTTOM_DOWN}}} \right) \times V_{\text{TH_DOWN}} \quad (22)$$

If desired, to select the capacitance (C_{DELAY}) for the UP pin we can use 方程式 23.

$$C_{DELAY} (F) > \frac{t_{DELAY}(s)}{R_{TH}(\Omega) \times \ln\left(\frac{V_{TH}(V)}{V(t) - V_{TH}(V)}\right)} \quad (23)$$

where:

- t_{DELAY} (s) is the desired delay time in seconds (at least 2.8ms after $V_{IN} > UVLO_{RISE}$).
- R_{TH} is the Thévenin equivalent resistance. In this case the parallel between R_{TOP} and R_{BOTTOM} in ohms.

$$R_{TH} (\Omega) = \frac{R_{TOP} (\Omega) \times R_{BOTTOM} (\Omega)}{R_{TOP} (\Omega) + R_{BOTTOM} (\Omega)} \quad (24)$$

- V_{TH} is the Thévenin equivalent voltage. In this case the voltage at V_{UP} during steady state operation in volts.

$$V_{TH} (V) = \left(\frac{R_{BOTTOM} (\Omega)}{R_{TOP} (\Omega) + R_{BOTTOM} (\Omega)}\right) \times V_{MAIN} (V) \quad (25)$$

- $V(t)$ is the voltage at UP (V_{UP}) which will start the sequence up. In this case 598mV \pm 3%, in volts.



图 8-13. Monitor a Main Rail to Automatically Start the Sequence UP and \overline{DOWN}

8.3.6 FAULT

The FAULT pin is an open-drain output that the user can use to monitor if an internal fault has been induced by the state machine. It is recommended to pull this pin to the VLDO output via a 10kΩ resistor. Another voltage source can be used if needed, but it is important that this voltage is stable and greater than 1V at all times. The maximum voltage at this pin is 7V. For proper operation this voltage must be stable before attempting a sequence up/down and must never go below 1V during the device operation. The open-drain FET is forced low when the internal state machine of the 序列发生器 detects a fault as described in [State Machine](#).

8.3.7 State Machine

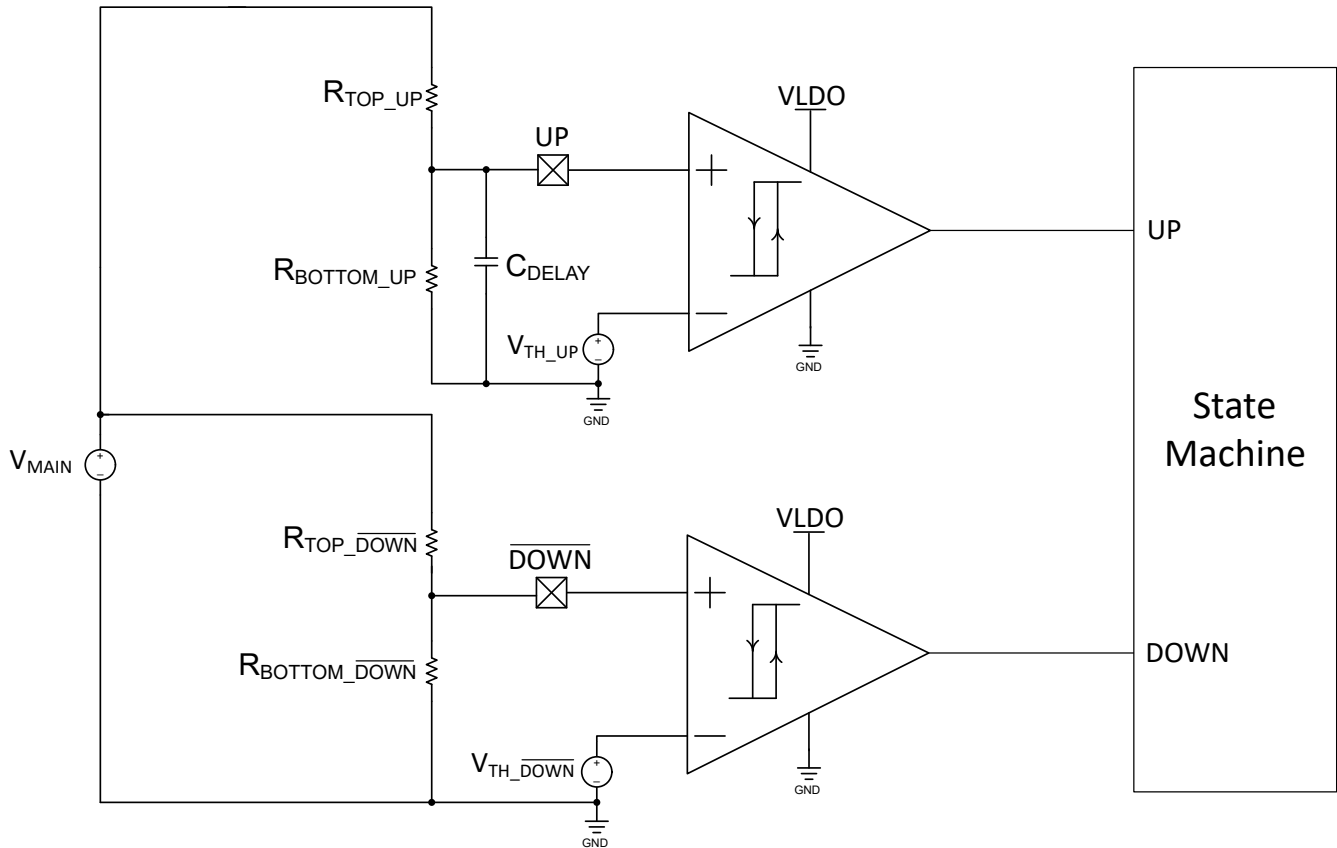
The TPS7H3014 incorporates a comprehensive state machine engine. Three possible outcomes are possible depending on the detected inputs states.

1. A reverse sequence down from previously deemed-good (forced high) ENx signals, is started if:
 - V_{OUTx} fails to reach the V_{ONx} voltage during sequence up within the time established by the REG_TMR, when ENx is high.
 - Any V_{OUTx} crosses the V_{OFFx} after previously crossing the V_{ONx} and the V_{OUTx+1} has not yet crossed the V_{ONx+1} .
 - The user commands a sequence down in the middle of a sequence up.
2. All outputs (ENx, SEQ_DONE and PWRGD) are forced low if an out-of-order is detected, this means:
 - A previously deemed-good rail V_{OUTx} drops below V_{OFFx} when at least the V_{OUTx+1} is already in regulation (deemed-good).
 - Any $V_{OUTx} > V_{ONx}$ when ENx is not high. **Valid only during sequence up.**

备注

It is typical in sequencers to set V_{ONx} as some percentage of the nominal voltage to be monitored (E.g. $V_{ONx} = 0.8 \times V_{OUTx}$). There is a period of time during sequence down at which the $V_{OUTx} \geq V_{ONx}$. As the discharge rate of the rail (V_{OUTx}) is unknown to the TPS7H3014, this feature is only valid during sequence up.

3. A sequence up from previously forced low ENx signals, after the DLY_TMR is expired is started if:
 - The user commands a sequence up in the middle of a sequence down.



图 8-14. TPS7H3014 State Machine Diagram

8.4 Daisy Chain

The TPS7H3014 incorporates four input channels to sequence/monitor up to four voltage rails. However, in the case where more than four channels are needed in the application, multiple devices can be daisy chained as needed. The daisy chain configuration is shown in [图 8-15](#). In this case, only two devices are shown, however multiple IC can be configured as needed by the application.

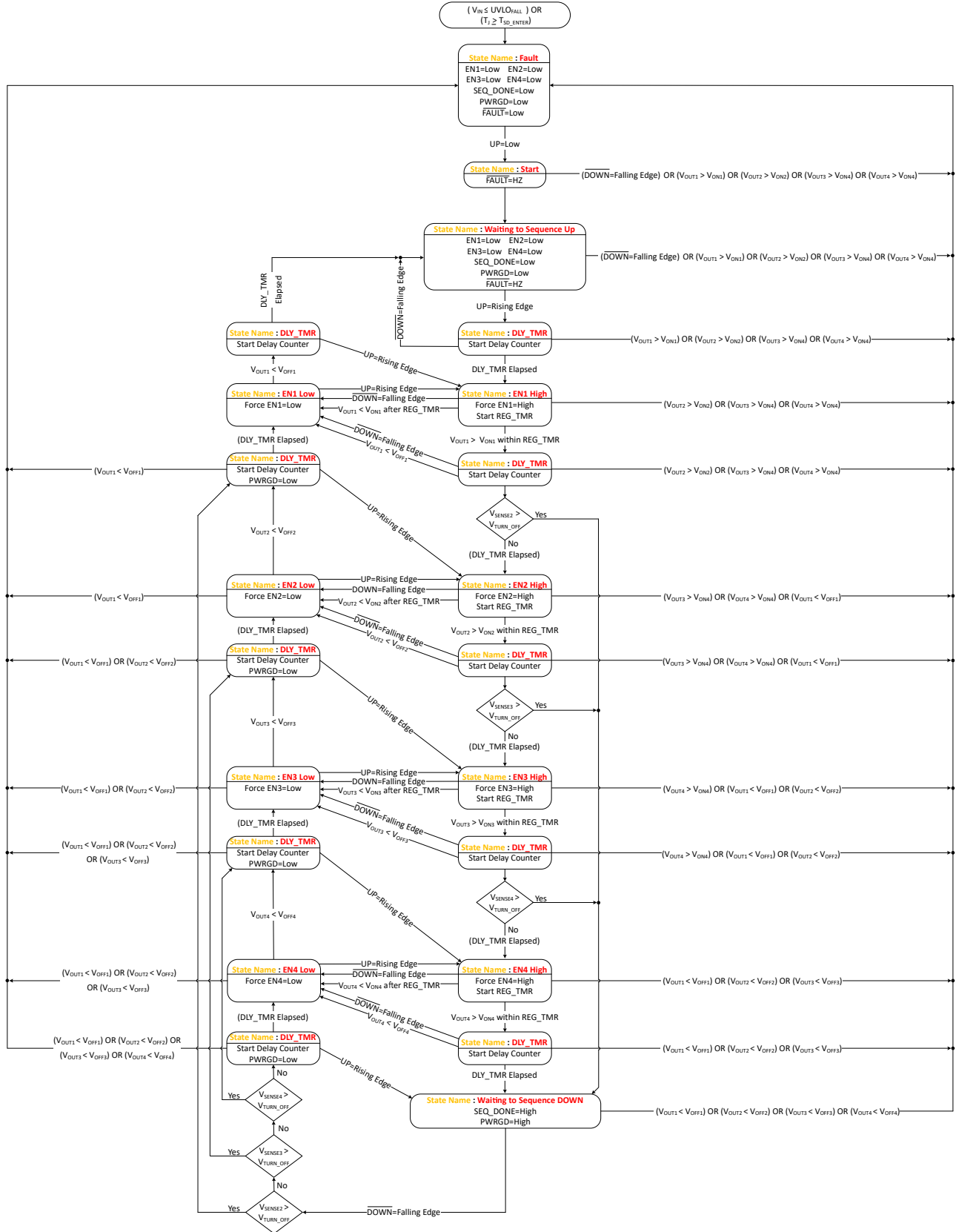

图 8-15. Daisy Chain Configuration

9 Application and Implementation

备注

Information in the following applications sections is not part of the TI component specification, and TI does not warrant its accuracy or completeness. TI's customers are responsible for determining suitability of components for their purposes, as well as validating and testing their design implementation to confirm system functionality.

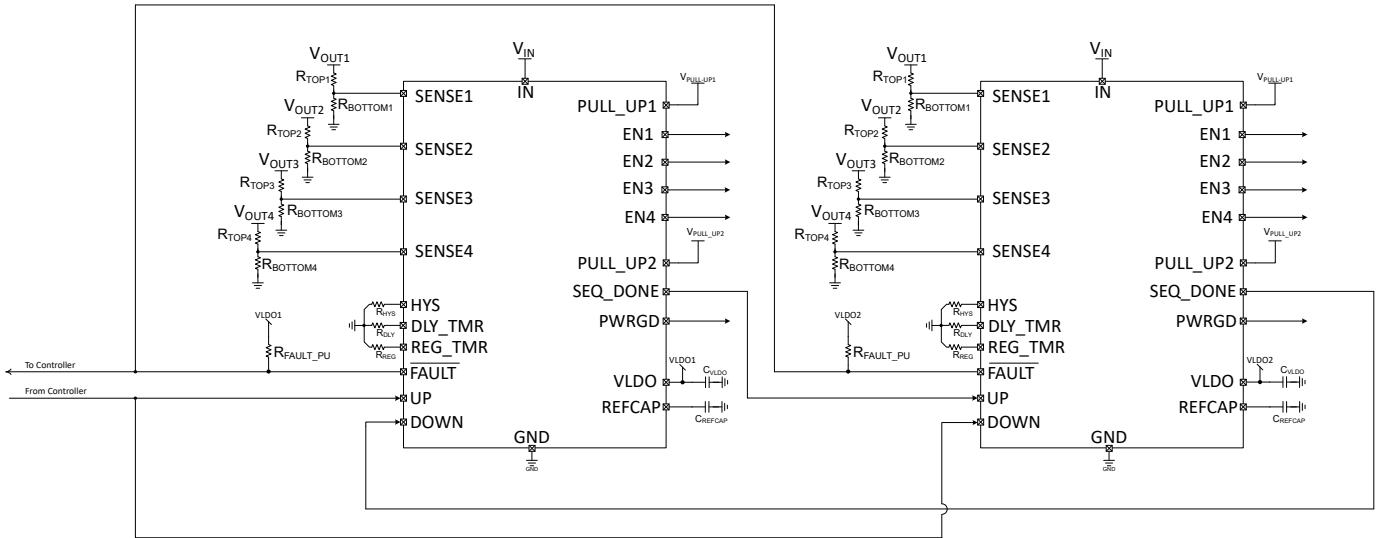
9.1 Application Information

The TPS7H3014 is a radiation hardened 4-channel sequencer. It can be used to sequence FPGAs, ASICs, AFEs, and various power systems

9.2 Typical Application

9.2.1 Self Contained - Sequence UP and DOWN

In many modern systems (or sub-systems), multiple voltage rails are often needed (we refer to this as the power tree). Often these power trees have a specified sequencing up order and reverse sequence down needed to guarantee reliable system operation. Is not uncommon for these systems to also have timing specifications which cannot be infringed for correct operation. In this example, four voltage rails are sequenced and monitored via the ENx outputs and SENSEx inputs, respectively. Detailed design procedure and component selection is provided below. The design is summarized in 图 9-1.



图 9-1. Self Contained Sequence UP/DOWN Design for a Four Voltage Rail Power Tree

9.2.1.1 Design Requirements

This design requires voltage sequencing of four voltage rails. The nominal TPS7H3014 input voltage is 12V and the sequencer is set to start the sequence up and down automatically when the voltage reaches the desired target voltage levels. All the voltage regulators are powered by a nominal 5V voltage rail. The system housekeeping microcontroller can monitor a fault via the voltage at the FAULT pin, which is pulled-up to VLDO. The PWRGD is the flag to be connected to the non-maskable interrupt of the system if it exists, or monitored by the MCU to know the status of the power tree. The SEQ_DONE can also be monitored to know if the sequence up/down are completed. All design conditions are defined in [表 9-1](#).

表 9-1. Design Conditions

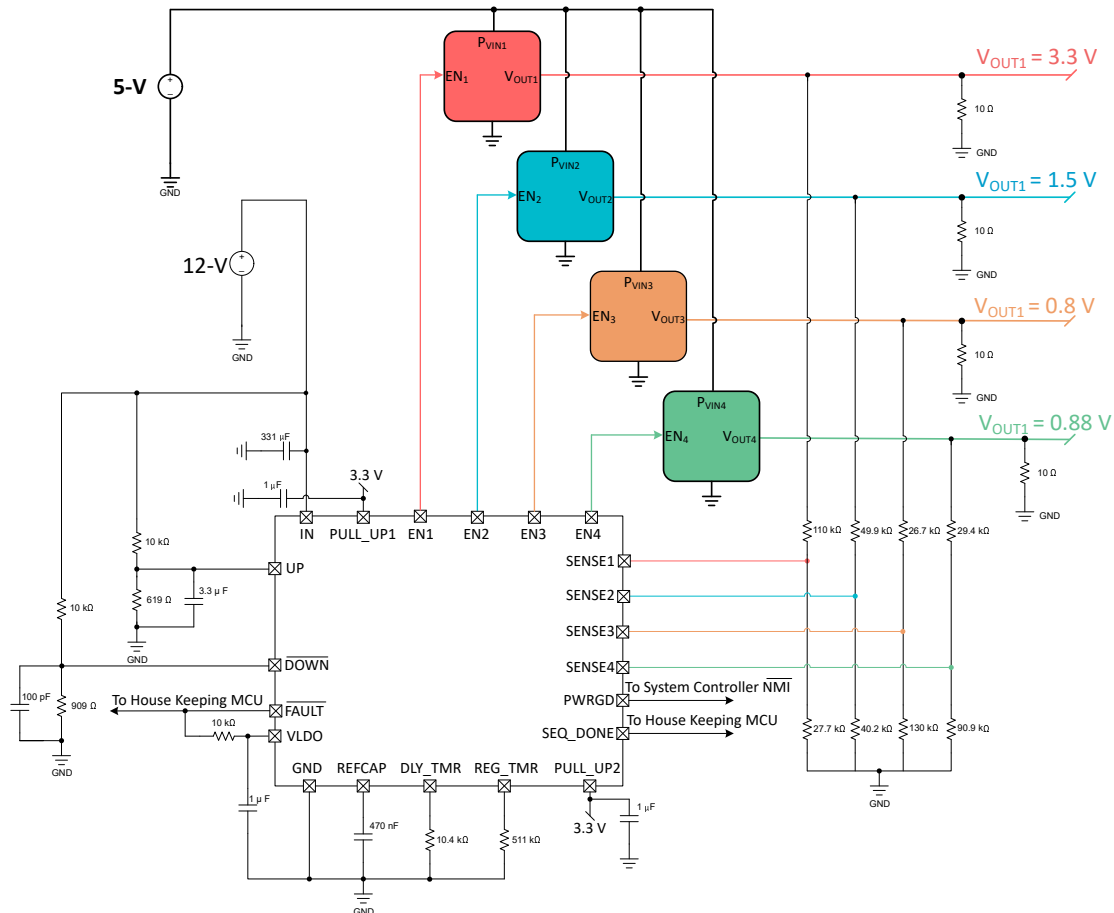
PARAMETER	DESIGN REQUIREMENT	DESIGN RESULT
System nominal voltage	Monitor the 12V input voltage and start the sequence up when the voltage is greater than 10.7V (88%) for at least 3.7ms. When the voltage decrements below 6V (or 50%) a sequence down is started.	The TPS7H3014 can monitor a voltage and start a sequence up and down automatically via a resistive divider. The internal reference in UP and DOWN have an accuracy of 3%. For minimal error, it is recommended to use 0.1% tolerance resistors.
V _{OUT1}	3.3V nominal with: V _{ON} = 90% and V _{OFF} = 10%	V _{ON} = 2.978V ±29.97mV V _{OFF} = 0.338V ±84.61mV Using 0.1% tolerance resistors
V _{OUT2}	0.8V nominal with: V _{ON} = 90% and V _{OFF} = 10%	V _{ON} = 0.722V ±7.22 mV V _{OFF} = 0.081V ±20.54mV Using 0.1% tolerance resistors
V _{OUT3}	1.5V nominal with: V _{ON} = 90% and V _{OFF} = 10%	V _{ON} = 1.343V ±13.47mV V _{OFF} = 0.145V ±38.35mV Using 0.1% tolerance resistors
V _{OUT4}	0.88V nominal with: V _{ON} = 90% and V _{OFF} = 10%	V _{ON} = 0.793V ±7.93mV V _{OFF} = 0.087V ±22.6mV Using 0.1% tolerance resistors
ENx delay during sequence up and down	Delay of 0.268ms nominal	R _{DLY_TMR} = 10.4kΩ
Allowed time for a rail to reach the V _{ONx}	Allow 10.3ms (nominal) for the rail to reach the V _{ONx}	R _{REG_TMR} = 511kΩ

9.2.1.2 Detailed Design Procedure

9.2.1.2.1 Input Power Supplies and Decoupling Capacitors

The TPS7H3014 has three input power supplies:

1. IN, the input supply to provide power to the TPS7H3014 IC. It is recommended to decouple this power supply with at least 1 μF as close to the pin as possible. In this application, V_{IN} = 12V.
2. PULL_UP1, which is the input supply to program the output voltage high (V_{OH}) of all the enable outputs (ENx). These outputs are connected to the regulator enable inputs to control the sequence up and down. It is recommended to decouple this power supply with at least 1 μF as close to the pin as possible. In this application, the V_{PULL_UP1} = 3.3V. This is a typical voltage used in electronic systems and satisfies the logic inputs of most regulators in the market.
3. PULL_UP2, which is the input supply to program the output voltage high (V_{OH}) of PWRGD and SEQ_DONE outputs. These outputs are typically connected to the system controller (typically an FPGA or ASIC) and/or to the house-keeping controller. In daisy chain configurations, SEQ_DONE is connected to UP of subsequent TPS7H3014 I.C. as shown in [图 8-15](#). It is recommended to decouple this power supply with at least 1 μF as close to the pin as possible. In this application, the V_{PULL_UP1} = 3.3V. This is a typical voltage of controller I/Os.

The TPS7H3014 also has two regulated voltage outputs that need to be decoupled for good electrical and radiation performance. These are:

1. REFCAP, the 1.2V reference, used internally in the device to generate all ratiometric voltage reference such as:

- V_{TH_SENSEX}
- I_{HYS_SENSEX}
- V_{TH_UP}
- V_{TH_DOWN}

Decouple this reference with a 470nF ceramic capacitor as close to the pin as possible. Do not load this pin externally.

2. VLDO, this is the output of the internal regulator used to provide power to the internal circuits on the TPS7H3014. Is recommended to decouple this regulator with at least 1 μ F as close to the pin as possible. The valid loading of this regulator is:

- To turn-off channels 2 - 4 as needed.
- To pull-up the \overline{FAULT} open-drain output.

9.2.1.2.2 UP and \overline{DOWN} Thresholds

In this application the UP and \overline{DOWN} pins are used to monitored the input voltage supply of 12V. A sequence up is started when the rail voltage is greater than 10.7 (typ) and down when the voltage is lower than 6V (typ). As the TPS7H3014 has an internal time constant ($t_{Start_up_delay}$) of 2.8ms (max), a delay capacitor of 3.3 μ F is added to UP pin. This capacitor is added to introduce a delay in the UP pin when V_{IN} is rising. This capacitor adds a second condition to start the sequence up, if $V_{IN} \geq 10.7V$ (typ) for at least 2.8ms then the sequence up is commanded.

Fixing the upper resistor for the resistive divider in UP and \overline{DOWN} , we can calculate the bottom resistor per our design requirements. The upper resistor is fixed to 10k Ω for both cases. Using the equations in 方程式 19 and 方程式 20, the bottom resistors for up and down are calculated as:

$$R_{BOTTOM_UP} = 10 \text{ k}\Omega \times \frac{0.598 \text{ V}}{10.7 \text{ V} - 0.598 \text{ V}} \cong 594 \Omega \quad (26)$$

$$R_{BOTTOM_DOWN} = 10 \text{ k}\Omega \times \frac{0.498 \text{ V}}{6 \text{ V} - 0.498 \text{ V}} \cong 905 \Omega \quad (27)$$

Now that the reference resistors are calculated, we can select the actual (or real) resistors. In this case 0.1% tolerance resistors are used to select the closest value as:

- $R_{BOTTOM_UP} = 619\Omega$
- $R_{BOTTOM_DOWN} = 909\Omega$

With the actual resistor values, we can back-calculate the nominal voltage to start the sequence up and down using 方程式 21 and 方程式 22 as:

$$V_{UP_NOMINAL} (V) = \left(1 + \frac{10 \text{ k}\Omega}{619 \Omega}\right) \times 12 \text{ V} \cong 10.66 \text{ V} \quad (28)$$

$$V_{\overline{DOWN}_NOMINAL} (V) = \left(1 + \frac{10 \text{ k}\Omega}{909 \Omega}\right) \times 12 \text{ V} \cong 5.97 \text{ V} \quad (29)$$

The delay capacitor is calculated using 方程式 23, 方程式 24, and 方程式 25 as:

$$R_{TH} (\Omega) = \frac{10 \text{ k}\Omega \times 619 \Omega}{10 \text{ k}\Omega + 619 \Omega} = 582.9 \Omega \quad (30)$$

$$V_{TH} (V) = \left(\frac{619 \Omega}{10 \text{ k}\Omega + 619 \Omega}\right) \times 12 \text{ V} = 0.7 \text{ V} \quad (31)$$

$$C_{DELAY} (F) \geq \frac{0.0028 \text{ s}}{582.9 \Omega \times \ln\left(-\frac{0.7 \text{ V}}{0.598 \text{ V} - 0.7 \text{ V}}\right)} = 2.49 \mu\text{F} \quad (32)$$

The delay capacitor is selected as 3.3 μF.

9.2.1.2.3 SENSEx Thresholds

The SENSEx inputs are used to monitor the voltage rails to be sequenced up and down. For this design the output voltages to be sequenced and monitored are:

1. $V_{OUT1} = 3.3V$
2. $V_{OUT2} = 0.8V$
3. $V_{OUT3} = 1.5V$
4. $V_{OUT4} = 0.88V$

The V_{ON} and V_{OFF} are selected to be 90% and 10% of the nominal voltage rail, for all the rails. Using [方程式 13](#) and [方程式 14](#) we can calculate the top and bottom reference resistors and select the closest resistor values using 0.1% resistor values. [表 9-2](#) shows the reference (or calculated) top and bottom resistors. [表 9-3](#) shows the selected resistors for the application.

表 9-2. SENSEx Reference Nominal Resistors

Channel #	V_{ON} (V)	V_{OFF} (V)	R_{TOP} (kΩ) ⁽¹⁾	R_{BOTTOM} (kΩ) ⁽¹⁾
1	2.970	0.330	110.0	27.8
2	1.350	0.150	50.0	39.9
3	0.720	0.080	26.7	132.0
4	0.792	0.088	29.3	91.0

(1) Values are rounded to one decimal place.

An example of how the top and bottom resistors for channel 1 (or SENSE1) were calculated are shown below:

$$\frac{2.970V - 0.330V}{24\mu A} = 110k\Omega \quad (33)$$

$$\frac{110k\Omega \times 0.599V}{2.970V - 0.599V} = 39.88k\Omega \quad (34)$$

表 9-3. SENSEx Selected Resistors Using 0.1 % Tolerance Resistors

Channel #	R_{TOP} (kΩ)	R_{BOTTOM} (kΩ)
1	110	27.7
2	49.9	40.2
3	26.7	130
4	29.4	90.9

Now that the actual resistors are known, we can calculate the actual on and off nominal voltages and the error voltages by using [方程式 1](#), [方程式 2](#), [方程式 3](#), [方程式 6](#), [方程式 7](#), and [方程式 12](#). Using the errors, we can calculate the upper and lower voltages and normalize the values with respect to the nominal output voltage.

表 9-4. V_{ON} Nominal Values With Statistics in Volts and Percentage

Channel #	$V_{ON_NOMINAL}$ (V) ⁽¹⁾	$V_{ON_NOMINAL}$ (%) ⁽¹⁾⁽⁴⁾	V_{ON_ERROR} (mV) ⁽¹⁾	V_{ON_LSL} (V) ⁽¹⁾⁽²⁾	V_{ON_LSL} (%) ⁽¹⁾⁽²⁾⁽⁴⁾	V_{ON_USL} (V) ⁽¹⁾⁽³⁾	V_{ON_USL} (%) ⁽¹⁾⁽³⁾⁽⁴⁾
1	2.978	90.232	29.966	2.948	89.325	3.008	91.141
2	1.343	89.502	13.466	1.329	88.605	1.356	90.400
3	0.722	90.253	7.222	0.715	89.350	0.729	91.156
4	0.793	90.084	7.932	0.785	89.182	0.801	90.985

- (1) Values are rounded to three decimal places.
- (2) LSL stands for lower specification limit or the min.
- (3) USL stands for upper specification limit or the max.
- (4) Values are normalized to the nominal output voltage for that rail.

表 9-5. V_{OFF} Nominal Values with Statistics in Volts and Percentage

Channel #	$V_{OFF_NOMINAL}$ (V) ⁽¹⁾	$V_{OFF_NOMINAL}$ (%) ^{(1) (4)}	V_{OFF_ERROR} (mV) ⁽¹⁾	V_{OFF_LSL} (V) ⁽¹⁾ (2)	V_{OFF_LSL} (%) ⁽¹⁾ (2) (4)	V_{OFF_USL} (V) ⁽¹⁾ (3)	V_{OFF_USL} (%) ⁽¹⁾ (3) (4)
1	0.338	10.233	84.613	0.253	7.669	0.422	12.797
2	0.145	9.662	38.354	0.107	7.105	0.183	12.219
3	0.081	10.153	20.535	0.061	7.586	0.102	12.720
4	0.087	9.902	22.604	0.065	7.333	0.110	12.470

- (1) Values are rounded to three decimal places.
(2) LSL stands for lower specification limit.
(3) USL stands for upper specification limit.
(4) Values are normalized to the nominal output voltage for that rail.

9.2.1.3 Application Curves



图 9-2. V_{IN} vs Time During Sequence UP



图 9-3. EN_1 and V_{OUT1} vs Time During Sequence UP

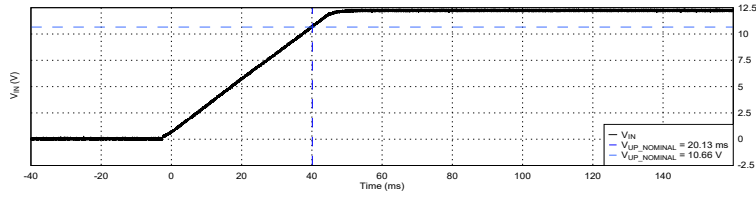

图 9-4. EN_2 and V_{OUT2} vs Time During Sequence UP

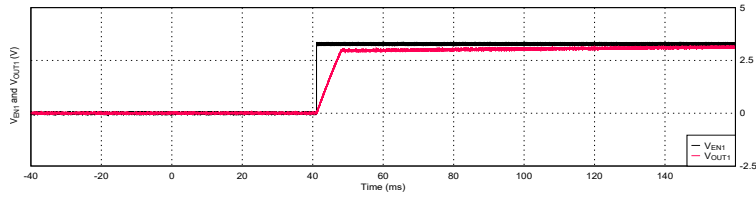

图 9-5. EN_3 and V_{OUT3} vs Time During Sequence UP

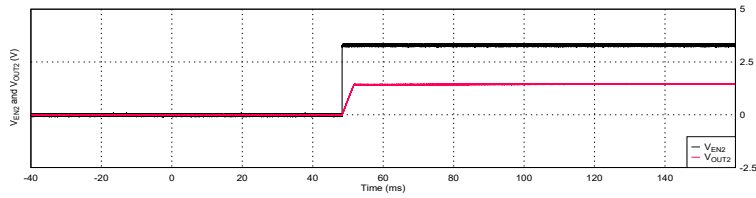

图 9-6. EN_4 and V_{OUT4} vs Time During Sequence UP

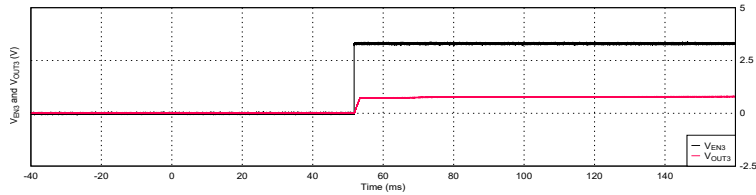

图 9-7. $PWRGD$ and SEQ_DONE vs Time During Sequence UP

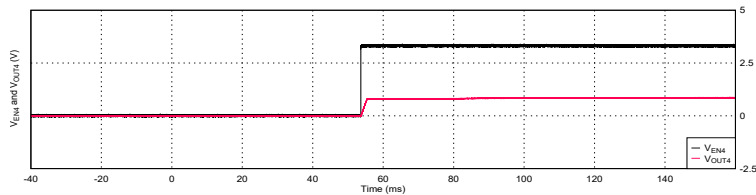

图 9-8. V_{IN} vs Time During Sequence DOWN

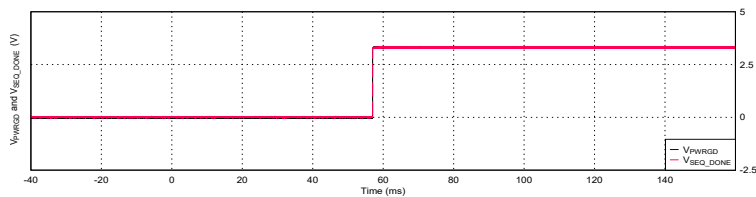

图 9-9. PWRGD and SEQ_DONE vs Time During Sequence DOWN

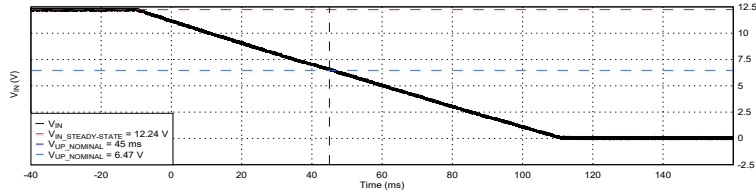

图 9-10. EN4 and V_{OUT4} vs Time During Sequence DOWN

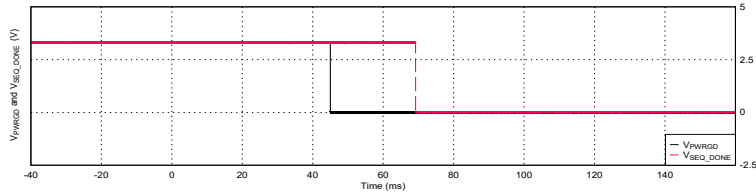

图 9-11. EN3 and V_{OUT3} vs Time During Sequence DOWN

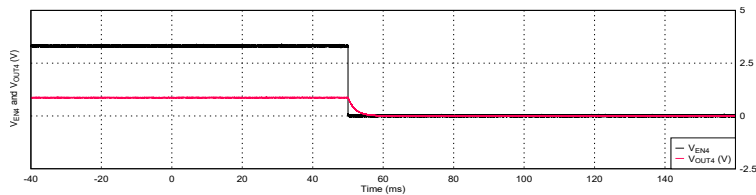

图 9-12. EN2 and V_{OUT2} vs Time During Sequence DOWN

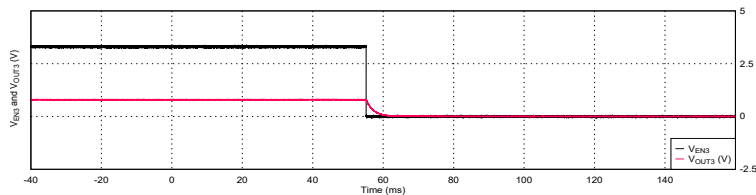

图 9-13. EN1 and V_{OUT1} vs Time During Sequence DOWN

9.2.2 Sequencing of Negative Voltage Rails

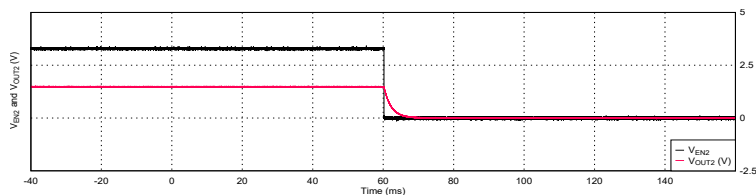
It is possible to sequence negative voltage rails using the TPS7H3014 with the support of some external circuitry such as:

1. Stable positive voltage reference.
2. Comparator with hysteresis.

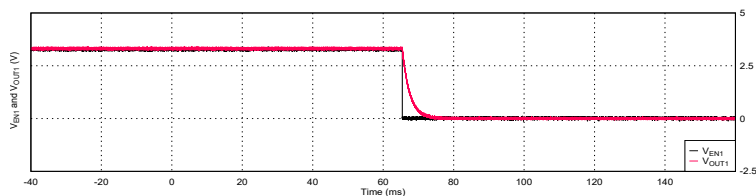
图 9-14, shows the typical connections to sense a negative voltage rail. When $-V_{OUTx}$ is at zero volts (initial state), the voltage at the inverting input of the external comparator is given by 方程式 35. The resistive divider is selected such that the initial voltage at the non-inverting input of the comparator is greater than the reference voltage by a desired factor. This factor depends on the desired threshold at which the negative voltage must be considered to be in regulation.

When the negative voltage rail ($-V_{OUTx}$) is turned-on the voltage at the non-inverting inputs starts decrementing until $-V_{OUTx}$ reaches steady-state. When the voltage at the non-inverting input is lower than the reference voltage the output of the comparators is forced high (the high value is determined by the positive bias of the comparator, V_+).

As the TPS7H3014 implements the hysteresis via a current, when the output of the external comparator is high, a typical $24 \mu A$ (I_{HYS_SENSEx}) are sunk into the output of the comparator. The selected comparator needs to be able to withstand this current sinking while maintaining a constant output.

R_x , R_y and R_h resistors attenuate the V_+ voltage to provide the thresholds that ultimately determines when the $-V_{OUTx}$ is considered to in or out of regulation. For more details refer to TIDU020 and 节 9.2.2.1.

$$V_{INVERTING_INPUT} (V) = \left(\frac{R_{TOP}(\Omega)}{R_{TOP}(\Omega) + R_{BOTTOM}(\Omega)} \right) \times V_{OFFSET} (V) \quad (35)$$



图 9-14. Sensing Negative Rails Using External Circuitry

备注

- When using external components to sense negative voltage rail the rising and falling threshold accuracy are dependent upon the external circuitry selected.
- The high voltage of the comparator must be below $V_{\text{TURN_OFF}}$, otherwise the channel is internally disabled. An resistive divider can be used to attenuate the output of the comparator if needed.

9.2.2.1 Negative Voltage Design Equations

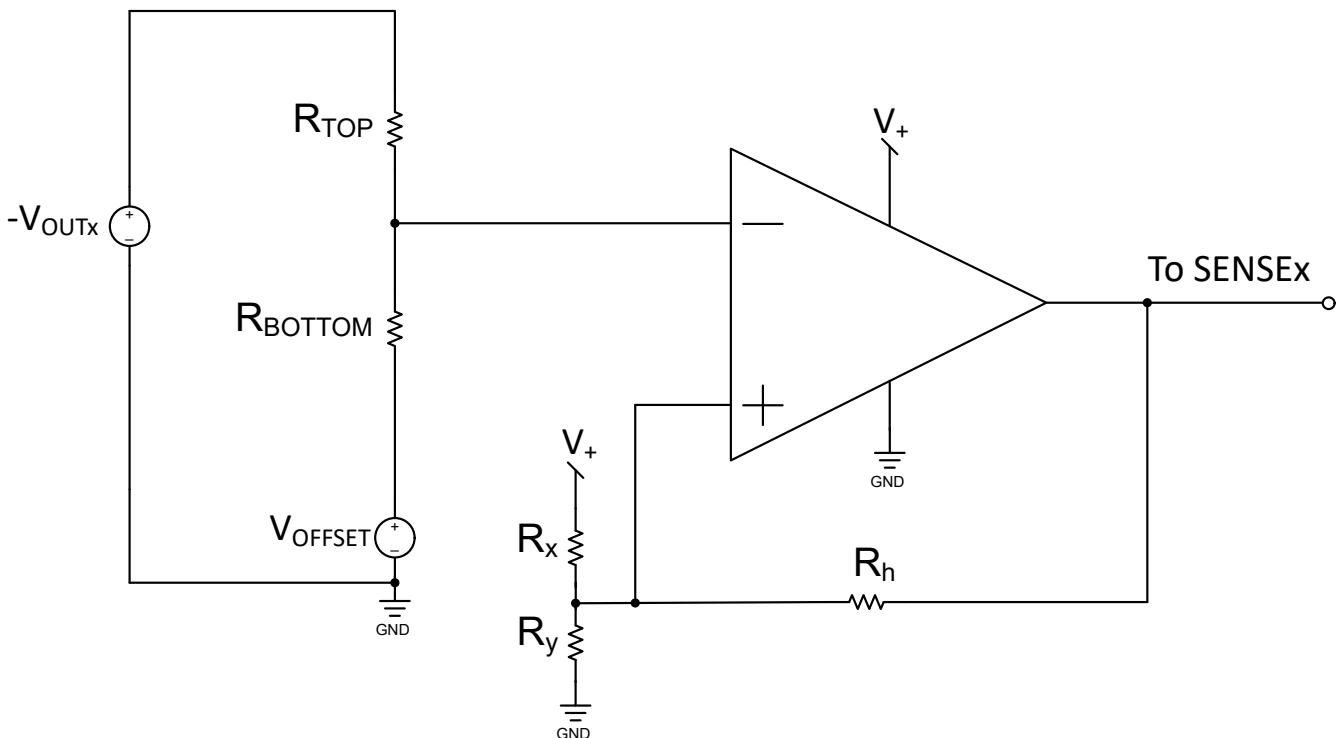
For the purpose of this discussion the following assumptions are made:

1. V_+ is provide from 2.5V stable reference voltage.
2. The output stage of the comparator is push-pull.
3. The negative voltage to be sequenced is -1.8V at steady-state.

The first step in the design is to select the voltages (or percent of the steady-state voltage) at which the negative rail is considered to be:

- In regulation
 - The -1.8V rail is considered to be in regulation when it is $>$ to 97% of the final value. In this case 1.746V. We refer to this as the on voltage (V_{ON})
- Not in regulation.
 - The -1.8V rail is considered not be in regulation when it is $<$ to 95% of the final value. In this case 1.71V. We refer to this as the off voltage (V_{OFF})

With this information we can calculate the hysteresis voltage as:

$$V_{\text{hys}}(\text{V}) = V_{\text{ON}}(\text{V}) - V_{\text{OFF}}(\text{V}) = 1.746\text{V} - 1.71\text{V} = 0.036\text{V} \quad (36)$$

The second step is determine the R_x , R_y and R_h resistors values used to generate the hysteresis reference voltages. These voltages are called V_L and V_H . We select V_L to be an attenuated value from the 2.5V reference. In this example we select V_L as 0.6V. V_H is calculated as:

$$V_H(\text{V}) = V_L(\text{V}) + V_{\text{hys}}(\text{V}) = 0.6\text{V} + 0.036\text{V} = 0.636\text{V} \quad (37)$$

With this information we can calculate the resistor ratio as:

$$\frac{R_h}{R_x} = \frac{V_L(\text{V})}{V_{\text{hys}}(\text{V})} = \frac{0.6}{0.036} = 16.67 \quad (38)$$

$$\frac{R_y}{R_x} = \frac{V_L(\text{V})}{V_+(\text{V}) - V_H(\text{V})} = \frac{0.6}{2.5 - 0.636} = 0.32 \quad (39)$$

The R_x value selected is $10\text{k}\Omega$ and R_y and R_h are calculated using [方程式 38](#) and [方程式 39](#). Using 0.1% tolerance resistors the selected values are:

- $R_y = 3.2\text{k}\Omega$
- $R_h = 165\text{k}\Omega$

As the actual resistors are known, we can calculate the actual V_L and V_H to be:

- $V_{H_REAL} = 0.633\text{V}$
- $V_{L_REAL} = 0.597\text{V}$

Finally we want to calculate the resistors for R_{TOP} and R_{BOTTOM} per [图 9-14](#). For this we can calculate an equivalent voltage at the inverting input when the $-V_{\text{OUTX}}$ must be considered to be on regulation as:

$$-V_{\text{OUT_EQ}}(\text{V}) = V_{\text{OFFSET}}(\text{V}) - V_{\text{ON}}(\text{V}) = 2.5\text{V} - 1.746\text{V} = -0.754\text{V} \quad (40)$$

Using this equivalent voltage and V_{L_REAL} we can calculate the ratio of the bottom to top resistor as:

$$\frac{R_{BOTTOM}}{R_{TOP}} = \frac{V_{L_REAL}(V)}{|-V_{OUT_EQ}(V)| - V_{L_REAL}(V)} = \frac{0.597}{0.754 - 0.597} = 3.8 \quad (41)$$

Using 0.1 % tolerance resistors and fixing R_{TOP} to 10k Ω , R_{BOTTOM} is selected as 38.2k Ω .

Now that all the final components are selected, we can calculate the real (or expected) on and off voltages as $V_{ON} = 1.746V$ and $V_{OFF} = 1.701V$

9.3 Externally Induced System RESET

In applications when it is necessary to propagate an externally detected fault into the TPS7H3014, an external FET can be connected from SENSE1 to GND. If SENSE1 is pulled to zero by turning on the FET connected to this pin, the internal state machine forces all outputs low. The FET off leakage ultimately affects the V_{OUT1} on and off accuracy. For this reason, it is important to choose a FET with minimal leakage. For more details, refer to section 3.6 (Externally Induced System RESET) in the [TPS7H3014EVM-CVAL EVM User Guide](#).

9.4 Power Supply Recommendations

The TPS7H3014 is designed to operate from an input supply (V_{IN}) with a voltage range between 3V to 14V. It is recommended to add at least one 1 μ F ceramic capacitor from V_{IN} to GND as close to the pin as possible.

The PULL_UP1 and PULL_UP2 are also considered power inputs in this case for the push-pull outputs. The voltage range on these inputs are 1.6V to 7V. For these inputs, it is also recommend to add at least one 1 μ F ceramic capacitor from PULL_UP1 to GND and from PULL_UP2 to GND. This capacitor must be placed as close to the pins as possible.

9.5 Layout

9.5.1 Layout Guidelines

- Make sure that the connection to the V_{IN} pin is low impedance. Place a greater than 1 μ F ceramic capacitor as near as possible to the V_{IN} pin.
- Make sure that the connection to the V_{PULL_UP1} and V_{PULL_UP2} pins are low impedance. Place a greater than 1 μ F ceramic capacitor as near as possible to the pins.
- If needed, place a small capacitor between the SENSEx pins and GND to reduce the sensitivity to transient voltages on the monitored signal.

9.5.2 Layout Example



图 9-15. Printed Circuit Board Layout Example: Top Layer



图 9-16. Printed Circuit Board Layout Example: Bottom Layer

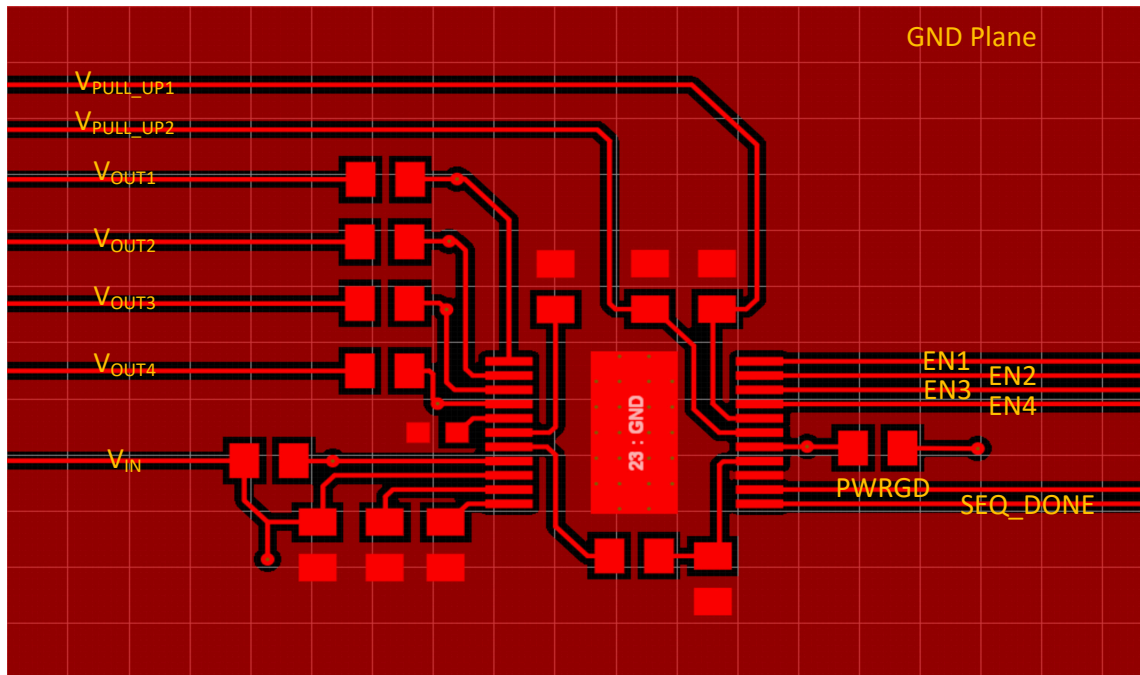

图 9-17. Printed Circuit Board Layout Example: Top Layer 3D View

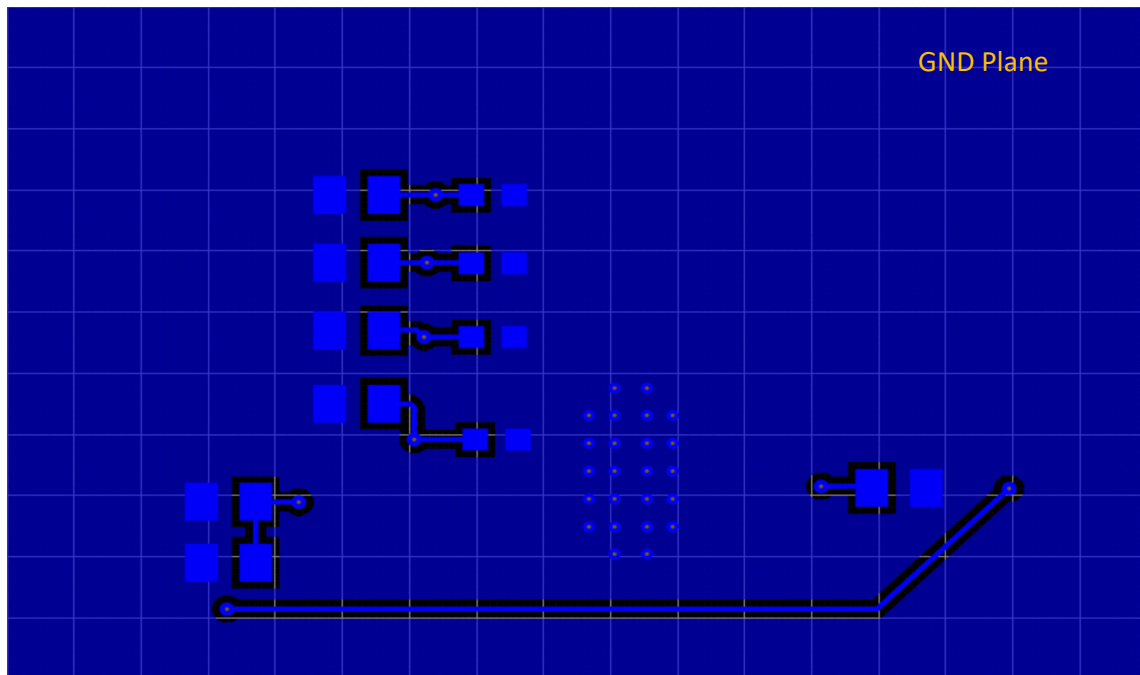

图 9-18. Printed Circuit Board Layout Example: Bottom Layer 3D View

10 Device and Documentation Support

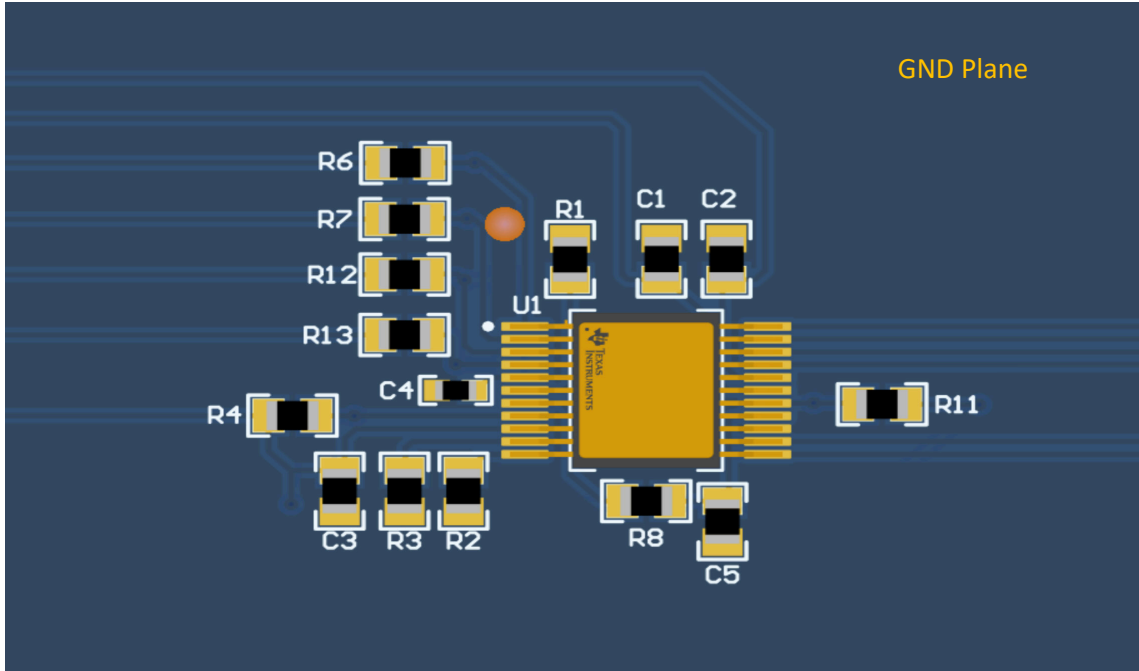
10.1 Documentation Support

10.1.1 Related Documentation

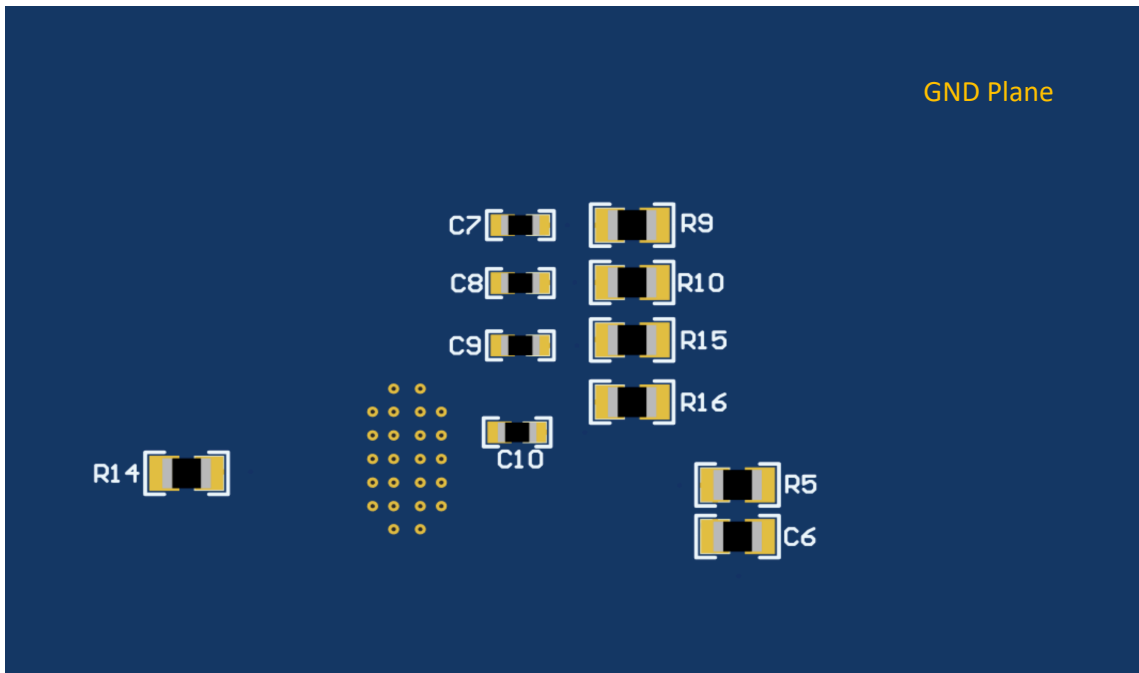
The following related documents are available for download at www.ti.com:

- [TPS7H3014EVM-CVAL EVM User Guide, SLVUCT9](#)
- [TPS7H3014-SP Total Ionizing Dose \(TID\), SLVK170](#)
- [TPS7H3014-SP Neutron Displacement Damage \(NDD\) Characterization Report, SLVK171](#)
- [TPS7H3014-SP Single-Event Effects \(SEE\) Report, SLVK172](#)
- [Standard Microcircuit Drawing](#)
- [Comparator with Hysteresis Reference Design, TIDU020](#)
- [IQ vs Accuracy Tradeoff In Designing Resistor Divider Input To A Voltage Supervisor, SLVA450](#)

10.2 接收文档更新通知

要接收文档更新通知，请导航至 ti.com 上的器件产品文件夹。点击 [通知](#) 进行注册，即可每周接收产品信息更改摘要。有关更改的详细信息，请查看任何已修订文档中包含的修订历史记录。

10.3 支持资源

[TI E2E™ 中文支持论坛](#) 是工程师的重要参考资料，可直接从专家处获得快速、经过验证的解答和设计帮助。搜索现有解答或提出自己的问题，获得所需的快速设计帮助。

链接的内容由各个贡献者“按原样”提供。这些内容并不构成 TI 技术规范，并且不一定反映 TI 的观点；请参阅 TI 的 [使用条款](#)。

10.4 Trademarks

TI E2E™ is a trademark of Texas Instruments.

所有商标均为其各自所有者的财产。

10.5 静电放电警告



静电放电 (ESD) 会损坏这个集成电路。德州仪器 (TI) 建议通过适当的预防措施处理所有集成电路。如果不遵守正确的处理和安装程序，可能会损坏集成电路。

ESD 的损坏小至导致微小的性能降级，大至整个器件故障。精密的集成电路可能更容易受到损坏，这是因为非常细微的参数更改都可能会导致器件与其发布的规格不相符。

10.6 术语表

[TI 术语表](#) 本术语表列出并解释了术语、首字母缩略词和定义。

11 Revision History

注：以前版本的页码可能与当前版本的页码不同

Changes from Revision A (May 2024) to Revision B (June 2024)	Page
• 通篇将 SMD 编号更新为 5962R2320101VXC.....	1
• Updated some sub-group numbers in the <i>Specifications</i> section.....	6
• Updated equations per range to minimize error in the <i>DLY_TMR</i> section.....	33
• Updated equations per range to minimize error in the <i>REG_TMR</i> section.....	34

Changes from Revision * (January 2024) to Revision A (May 2024)	Page
• 将文档状态从 <i>预告信息</i> 更改为 <i>量产数据</i>	1

12 Mechanical, Packaging, and Orderable Information

The following pages include mechanical, packaging, and orderable information. This information is the most current data available for the designated devices. This data is subject to change without notice and revision of this document. For browser-based versions of this data sheet, refer to the left-hand navigation.

PACKAGING INFORMATION

Orderable Device	Status (1)	Package Type	Package Drawing	Pins	Package Qty	Eco Plan (2)	Lead finish/ Ball material (6)	MSL Peak Temp (3)	Op Temp (°C)	Device Marking (4/5)	Samples
5962R2320101VXC	ACTIVE	CFP	HFT	22	25	RoHS & Green	NIAU	N / A for Pkg Type	-55 to 125	5962R2320101VXC TPS7H3014MHFTV	Samples
TPS7H3014HFT/EM	ACTIVE	CFP	HFT	22	25	RoHS & Green	NIAU	N / A for Pkg Type	25 to 25	TPS7H3014HFTEM EVAL ONLY	Samples

(1) The marketing status values are defined as follows:

ACTIVE: Product device recommended for new designs.

LIFEBUY: TI has announced that the device will be discontinued, and a lifetime-buy period is in effect.

NRND: Not recommended for new designs. Device is in production to support existing customers, but TI does not recommend using this part in a new design.

PREVIEW: Device has been announced but is not in production. Samples may or may not be available.

OBsolete: TI has discontinued the production of the device.

(2) **RoHS:** TI defines "RoHS" to mean semiconductor products that are compliant with the current EU RoHS requirements for all 10 RoHS substances, including the requirement that RoHS substance do not exceed 0.1% by weight in homogeneous materials. Where designed to be soldered at high temperatures, "RoHS" products are suitable for use in specified lead-free processes. TI may reference these types of products as "Pb-Free".

RoHS Exempt: TI defines "RoHS Exempt" to mean products that contain lead but are compliant with EU RoHS pursuant to a specific EU RoHS exemption.

Green: TI defines "Green" to mean the content of Chlorine (Cl) and Bromine (Br) based flame retardants meet JS709B low halogen requirements of <=1000ppm threshold. Antimony trioxide based flame retardants must also meet the <=1000ppm threshold requirement.

(3) MSL, Peak Temp. - The Moisture Sensitivity Level rating according to the JEDEC industry standard classifications, and peak solder temperature.

(4) There may be additional marking, which relates to the logo, the lot trace code information, or the environmental category on the device.

(5) Multiple Device Markings will be inside parentheses. Only one Device Marking contained in parentheses and separated by a "~" will appear on a device. If a line is indented then it is a continuation of the previous line and the two combined represent the entire Device Marking for that device.

(6) Lead finish/Ball material - Orderable Devices may have multiple material finish options. Finish options are separated by a vertical ruled line. Lead finish/Ball material values may wrap to two lines if the finish value exceeds the maximum column width.

Important Information and Disclaimer:The information provided on this page represents TI's knowledge and belief as of the date that it is provided. TI bases its knowledge and belief on information provided by third parties, and makes no representation or warranty as to the accuracy of such information. Efforts are underway to better integrate information from third parties. TI has taken and continues to take reasonable steps to provide representative and accurate information but may not have conducted destructive testing or chemical analysis on incoming materials and chemicals. TI and TI suppliers consider certain information to be proprietary, and thus CAS numbers and other limited information may not be available for release.

In no event shall TI's liability arising out of such information exceed the total purchase price of the TI part(s) at issue in this document sold by TI to Customer on an annual basis.

TUBE

*All dimensions are nominal

Device	Package Name	Package Type	Pins	SPQ	L (mm)	W (mm)	T (μm)	B (mm)
5962R2320101VXC	HFT	CFP	22	25	506.98	32.77	9910	NA
TPS7H3014HFT/EM	HFT	CFP	22	25	506.98	32.77	9910	NA

HFT0022A



PACKAGE OUTLINE

CFP - 2.428mm max height

CERAMIC FLATPACK

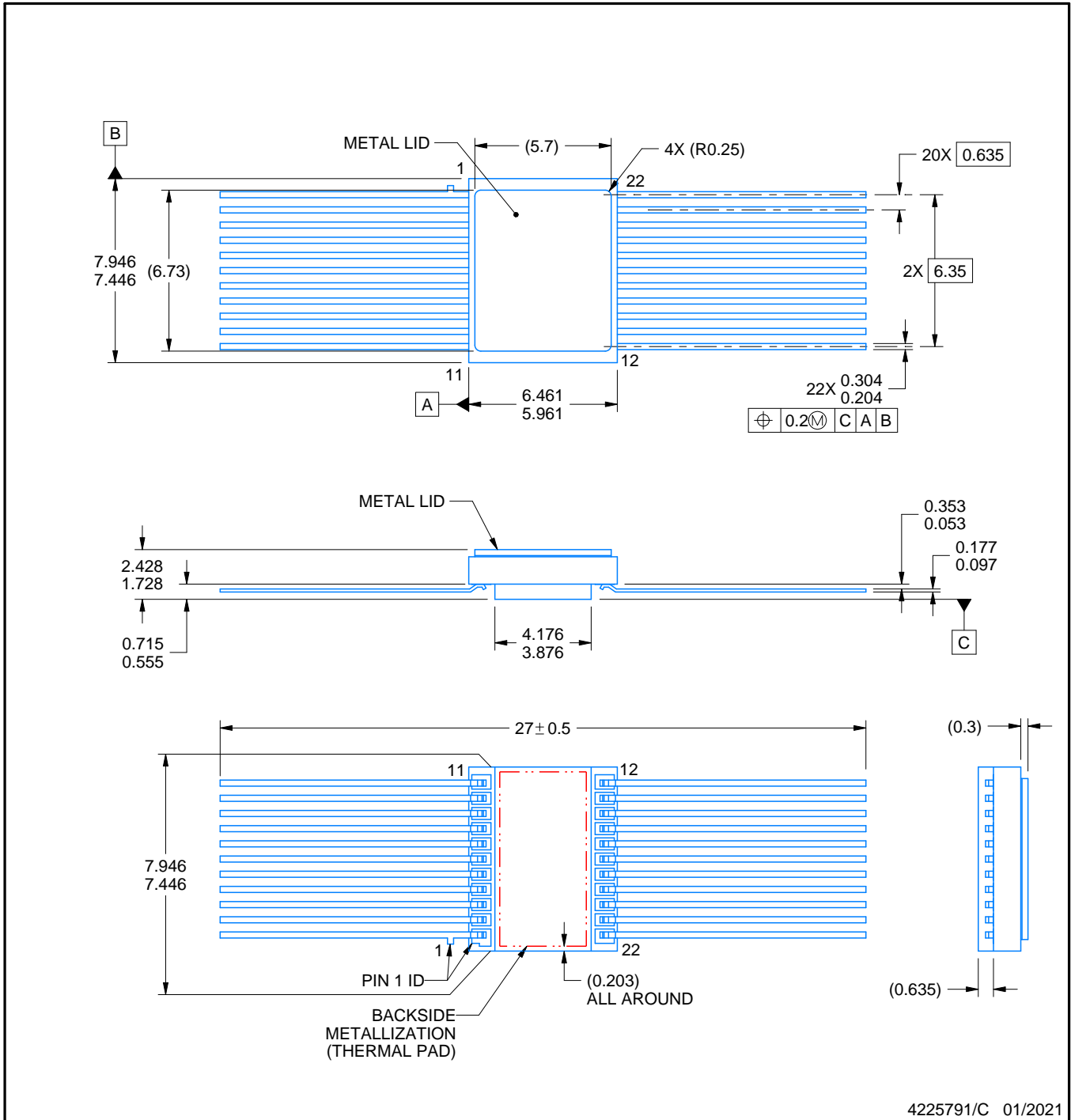

4225791/C 01/2021

NOTES:

1. All linear dimensions are in millimeters. Any dimensions in parenthesis are for reference only. Dimensioning and tolerancing per ASME Y14.5M.
2. This drawing is subject to change without notice.
3. This package is hermetically sealed with a metal lid. The lid is not connected to any lead.
4. The leads are gold plated.
5. Metal lid is connected to backside metallization

EXAMPLE BOARD LAYOUT

HFT0022A

CFP - 2.428mm max height

CERAMIC FLATPACK

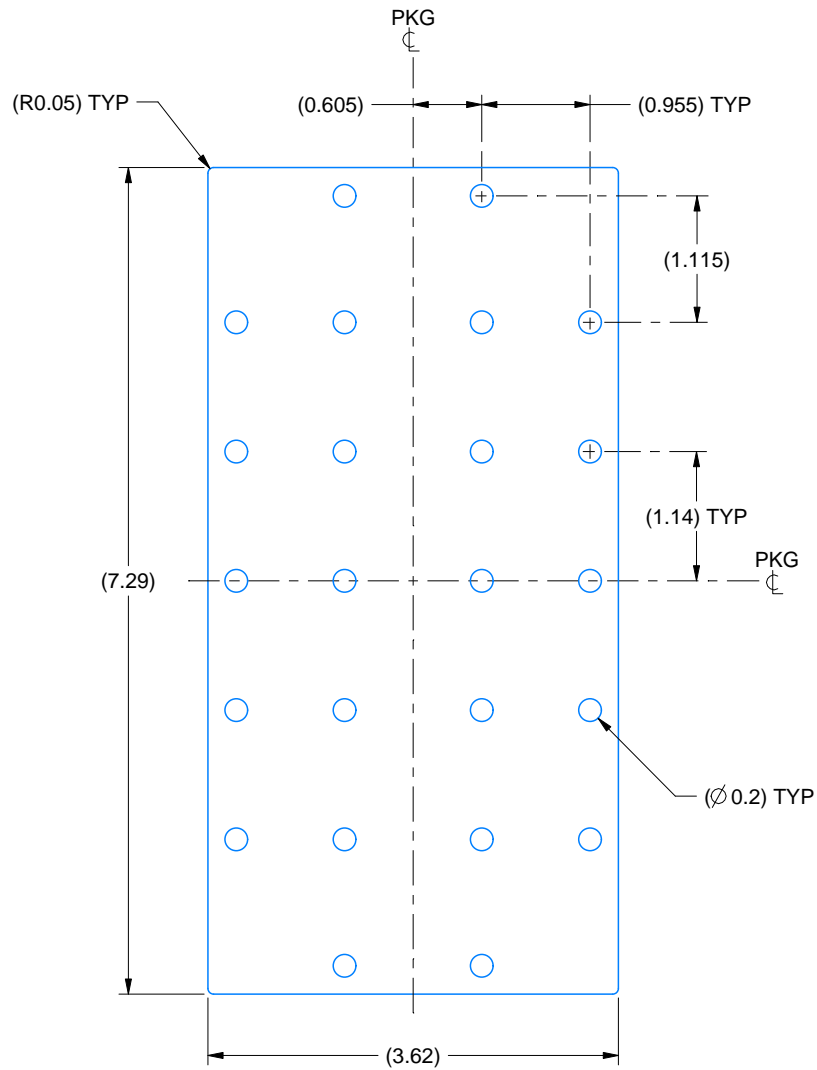

HEATSINK LAND PATTERN EXAMPLE
EXPOSED METAL SHOWN
SCALE:15X

4225791/C 01/2021

REVISIONS

REV	DESCRIPTION	ECR	DATE	ENGINEER / DRAFTER
A	RELEASE NEW DRAWING	2186323	03/13/2020	R. RAZAK / ANIS FAUZI
B	ADD LAND PATTERN VIEW / SHEET	2190485	10/22/2020	R. RAZAK / ANIS FAUZI
C	UPDATE TOTAL LEAD LENGTH TO 27 ± 0.5	2192775	01/28/2021	R. RAZAK / ANIS FAUZI

重要声明和免责声明

TI“按原样”提供技术和可靠性数据（包括数据表）、设计资源（包括参考设计）、应用或其他设计建议、网络工具、安全信息和其他资源，不保证没有瑕疵且不做任何明示或暗示的担保，包括但不限于对适销性、某特定用途方面的适用性或不侵犯任何第三方知识产权的暗示担保。

这些资源可供使用 TI 产品进行设计的熟练开发人员使用。您将自行承担以下全部责任：(1) 针对您的应用选择合适的 TI 产品，(2) 设计、验证并测试您的应用，(3) 确保您的应用满足相应标准以及任何其他功能安全、信息安全、监管或其他要求。

这些资源如有变更，恕不另行通知。TI 授权您仅可将这些资源用于研发本资源所述的 TI 产品的应用。严禁对这些资源进行其他复制或展示。您无权使用任何其他 TI 知识产权或任何第三方知识产权。您应全额赔偿因在这些资源的使用中对 TI 及其代表造成的任何索赔、损害、成本、损失和债务，TI 对此概不负责。

TI 提供的产品受 [TI 的销售条款](#) 或 [ti.com](#) 上其他适用条款/TI 产品随附的其他适用条款的约束。TI 提供这些资源并不会扩展或以其他方式更改 TI 针对 TI 产品发布的适用的担保或担保免责声明。

TI 反对并拒绝您可能提出的任何其他或不同的条款。

邮寄地址：Texas Instruments, Post Office Box 655303, Dallas, Texas 75265

Copyright © 2024，德州仪器 (TI) 公司