

# TPSM8D6C24 2.95V 至 16V、双路 35A 或单路 70A、最多可堆叠 4 个相位、PMBus® 降压电源模块

## 1 特性

- 4.25V 至 16V，PVIN 连接至 AVIN 与内部的 LDO
- 2.95V 至 16V，PVIN 和 AVIN 双电源，或 VDD5 上的外部偏压范围
- 集成 MOSFET、电感器和基本无源器件
- 具有可选内部补偿的平均电流模式控制
- 通过引脚搭接实现的输出电压范围为 0.5V 至 3.6V
- 0.25V 至 3.6V PMBus® VOUT\_COMMAND 范围
- 广泛的 PMBus 命令集，可遥测 V<sub>OUT</sub>、I<sub>OUT</sub> 和内核温度
- 通过内部反馈分压器实现差分遥感，可检测到小于 1% 的 V<sub>OUT</sub> 误差
- -40°C 至 +125°C 的结温范围
- 通过 PMBus 实现 AVS 和裕量调节
- 多功能选择 (MSEL) 引脚，采用引脚搭接编程 PMBus 默认值
- 九个可选开关频率范围：275kHz 至 1.1MHz
- 频率同步输入和同步输出
- 支持预偏置输出
- 16mm x 20mm x 4.3mm 59 引脚 MOW 封装
- 使用 TPSM8D6C24 并借助 **WEBENCH® Power Designer** 创建定制设计方案

## 2 应用

- 数据中心交换机、机架式服务器
- 有源天线系统、远程射频和基带单元
- 自动化测试设备、CT、PET 和 MRI
- ASIC、SoC、FPGA、DSP 内核和 I/O 电压

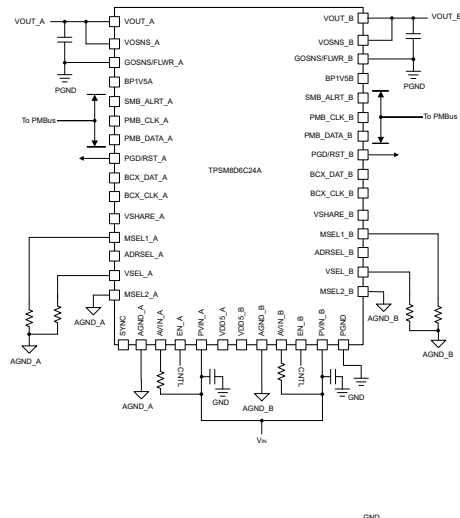

简化版应用

## 3 说明

TPSM8D6C24 是一款高度集成、易于使用的非隔离式直流/直流降压电源模块。TPSM8D6C24 提供两个 35A 独立输出或单个堆叠式两相 70A 输出。可以堆叠两个模块以获得 4 相 140A 输出。该器件可通过外部 5V 电源对内部的 5V LDO 进行过驱动，以实现低至 2.95V 的较低输入电压范围并提高转换器的效率。

TPSM8D6C24 电源模块使用专用的固定频率电流模式控制，具有输入前馈和可选的内部补偿元件，可在各种输出电容下更大限度减小尺寸和提高稳定性。

PMBus 接口具有 1MHz 时钟支持，为转换器配置提供了便捷且标准化的数字接口，并且实现了对输出电压、输出电流和内核温度等关键参数的监控。对故障状况的响应可设置为重新启动、锁存或忽略，具体取决于系统要求。堆叠器件之间的反向通道通信会启用所有 TPSM8D6C24 转换器，以便为单个输出轨供电以共享一个地址，从而简化系统软件或固件设计。也可通过 BOM 选择不进行 PMBus 通信的情况下，配置输出电压、开关频率、软启动时间和过流故障限制等关键参数，以支持无程序加电。

### 封装信息

器件型号	封装 <sup>(1)</sup>	封装尺寸 <sup>(2)</sup>
TPSM8D6C24	MOW ( QFM、59 )	16.00mm x 20.00mm

- (1) 有关详细信息，请参阅节 10。
- (2) 封装尺寸（长 x 宽）为标称值，并包括引脚（如适用）

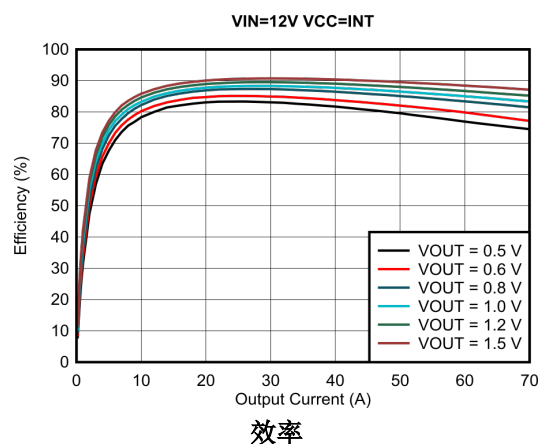

效率



## Table of Contents

<b>1 特性</b> .....	<b>1</b>	<b>7 Application and Implementation</b> .....	<b>150</b>
<b>2 应用</b> .....	<b>1</b>	7.1 Application Information.....	150
<b>3 说明</b> .....	<b>1</b>	7.2 Typical Application.....	150
<b>4 Pin Configuration and Functions</b> .....	<b>3</b>	7.3 Two-Phase Application.....	158
<b>5 Specifications</b> .....	<b>5</b>	7.4 Four-Phase Application.....	163
5.1 Absolute Maximum Ratings .....	5	7.5 Power Supply Recommendations.....	165
5.2 ESD Ratings .....	5	7.6 Layout.....	165
5.3 Recommended Operating Conditions .....	5	<b>8 Device and Documentation Support</b> .....	<b>168</b>
5.4 Thermal Information .....	6	8.1 Device Support.....	168
5.5 Electrical Characteristics .....	6	8.2 接收文档更新通知.....	168
5.6 Typical Characteristics.....	14	8.3 支持资源.....	168
<b>6 Detailed Description</b> .....	<b>17</b>	8.4 Trademarks.....	168
6.1 Overview.....	17	8.5 静电放电警告.....	168
6.2 Functional Block Diagram.....	17	8.6 术语表.....	169
6.3 Feature Description.....	18	<b>9 Revision History</b> .....	<b>169</b>
6.4 Device Functional Modes.....	33	<b>10 Mechanical, Packaging, and Orderable Information</b> .....	<b>170</b>
6.5 Programming.....	34		
6.6 Register Maps.....	46		

### 4 Pin Configuration and Functions



图 4-1. 59-Pin QFM-MOW Package (Top View)



图 4-2. 59-Pin QFM-MOW Package (Bottom View)

表 4-1. Pin Functions

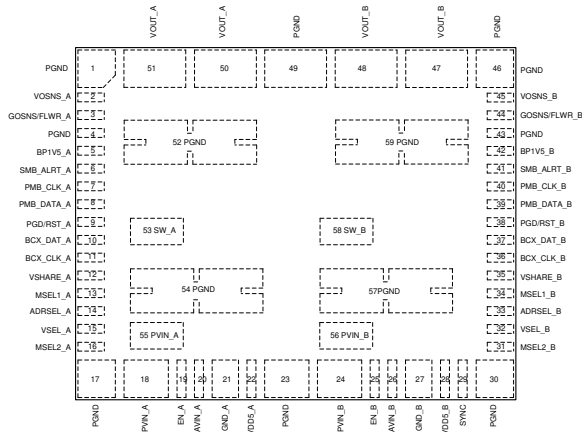
Pin		Type <sup>(1)</sup>	Description
Name	NO.		
PGND	1, 4, 17, 23, 30, 43, 46, 49, 52, 54, 57, 59	—	Power stage ground return. Pins 52, 54, 57, and 59 also act as the thermal pad of the device.
VOSNS_A	2	I	The positive input of the remote sense amplifier. For a standalone device or a loop controller device in a multi-phase configuration, connect the VOSNS pin to the output voltage at the load. For the loop follower device in a multi-phase configuration, the remote sense amplifier is not required for output voltage sensing or regulation and this pin can be left floating. If used to monitor another voltage with the phased <a href="#">READ_VOUT</a> command, VOSNS must be maintained between 0 V and 0.75 V with a < 1-kΩ resistor divider due to the internal resistance to GOSNS, which is connected to BP1V5.
VOSNS_B	45		
GOSNS/FLWR_A	3	I	The negative input of the remote sense amplifier for a loop controller device or pull up high to indicate a loop follower. For a standalone device or a loop controller device in a multi-phase configuration, connect the GOSNS pin to the ground at the load. For the loop follower device in a multi-phase configuration, the GOSNS pin must be pulled up to BP1V5 to indicate the device is a loop follower.
GOSNS/FLWR_B	44		
BP1V5_A	5	O	Output of the 1.5-V internal regulator for MSEL,VSEL, and ADRSEL pins. No external bypassing required. Not designed to power other circuits
BP1V5_B	42		
SMB_ALRT_A	6	O	SMBus alert pin. See the SMBus specification
SMB_ALRT_B	41		
PMB_CLK_A	7	I	PMBus CLK pin. See the <a href="#">Current PMBus Specifications</a> .
PMB_CLK_B	40		
PMB_DATA_A	8	I/O	PMBus DATA pin. See the <a href="#">Current PMBus Specifications</a> .
PMB_DATA_B	39		
PGD/RST_A	9	I/O	Open-drain power good or (21h) <a href="#">VOUT_COMMAND</a> RESET#. As determined by user-programmable RESET# bit in (EDh) <a href="#">MFR_SPECIFIC_29 (MISC_OPTIONS)</a> . The default pin function is an open-drain power-good indicator. When configured as RESET#, an internal pullup can be enabled or disabled by the PULLUP# bit in (EDh) <a href="#">MFR_SPECIFIC_29 (MISC_OPTIONS)</a> .
PGD/RST_B	38		
BCX_DATA_A	10	I/O	Data for back-channel communications between stacked devices
BCX_DATA_B	37		
BCX_CLK_A	11	I/O	Clock for back-channel communications between stacked devices
BCX_CLK_B	36		

表 4-1. Pin Functions (续)

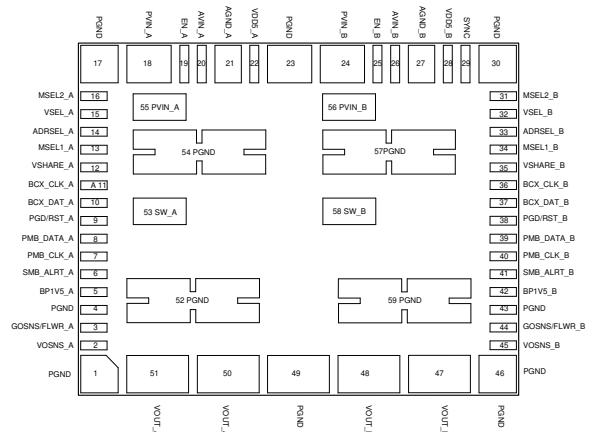
Pin		Type <sup>(1)</sup>	Description
Name	NO.		
VSHARE_A	12	I/O	Voltage sharing signal for multi-phase operation. For a standalone device, the VSHARE pin must be left floating. VSHARE can be bypassed to AGND with up to 50 pF of capacitance.
VSHARE_B	35		
MSEL1_A	13	I	Connect this pin to a resistor divider between BP1V5 and AGND for different options of switching frequency and internal compensation parameters. See the <a href="#">Programming MSEL1</a> section.
MSEL1_B	34		
ADRSEL_A	14	I	Connect this pin to a resistor divider between BP1V5 and AGND for different options of PMBus addresses and frequency sync (including determination of SYNC pin as SYNCIN or SYNCOUT function). See the <a href="#">Programming ADRSEL</a> section.
ADRSEL_B	33		
VSEL_A	15	I	Connect this pin to a resistor divider between BP1V5 and AGND for different options of internal voltage feedback dividers and default output voltage. See <a href="#">Programming VSEL</a> .
VSEL_B	32		
MSEL2_A	16	I	Connect this pin to a resistor divider between BP1V5 and AGND for different options of soft-start time, overcurrent fault limit, and multiphase information. See the <a href="#">Programming MSEL2</a> or <a href="#">Programming MSEL2 for a Loop Follower Device (GOSNS Tied to BP1V5)</a> sections for a loop follower device (GOSNS tied to BP1V5) if GOSNS is tied to BP1V5.
MSEL2_B	31		
EN/UVLO_A	19	I	Enable switching as the PMBus CONTROL pin. EN/UVLO can also be connected to a resistor divider to program input voltage UVLO.
EN/UVLO_B	25		
PVIN_A	18, 55	I	Input power to the power stage. Low-impedance bypassing of these pins to PGND is critical. PVIN to PGND must be bypassed with X5R or better ceramic capacitors rated for at least 1.5× the maximum PVIN voltage.
PVIN_B	24, 56		
AVIN_A	20	I	Input power to the controller
AVIN_B	26		
AGND_A	21	—	Analog ground return for controller. Connect the AGND pin directly to the thermal pad on the PCB board.
AGND_B	27		
VDD5_A	22	O	Output of the 5-V internal regulator. A bypassing capacitor is integrated and no external bypassing is required.
VDD5_B	28		
SYNC	29	I/O	For frequency synchronization, this pin can be programmed as SYNC IN or SYNC OUT pin by the ADRSEL pin or the <a href="#">(E4h) MFR_SPECIFIC_20 (SYNC_CONFIG)</a> PMBus command. SYNC is tied together internally for phase A and B. SYNC pin can be left floating when using module in single-phase configuration.
VOUT_A	50, 51	O	Output of each channel. Connect to output bypass capacitors to this pin.
VOUT_B	47, 48		
Thermal Pad	52, 54, 57, 59	—	The thermal pad is the PGND pin made with a large area of copper to improve thermal conductivity to PCB. The thermal pad must have adequate solder coverage for best thermal performance.
SW_A	53	I/O	Switched power output of the device. Connect the output averaging filter and bootstrap to this group of pins if needed.
SW_B	58		

(1) I = input, O = output

## 5 Specifications

### 5.1 Absolute Maximum Ratings

over operating free-air temperature range (unless otherwise noted) <sup>(1)</sup>

		MIN	MAX	UNIT
Input voltage	AVIN	- 0.3	18	V
	PVIN	- 0.3	16	
	PVIN_A, PVIN_B, < 2-ms transient	- 0.3	19	
	EN/UVLO, VOSNS, SYNC, VSEL, MSEL1, MSEL2, ADRSEL	- 0.3	5.5	
	VSHARE, GOSNS/LOOP FLWR	- 0.3	1.98	
	PMB_CLK, PMB_DATA, BCX_CLK, BCX_DAT	- 0.3	5.5	
	VDD5 external bias range	4.25	5.25	
Output voltage	VOUT	0.5	3.6	V
	VDD5, SMB_ALRT, PGD/RST	- 0.3	5.5	
	BP1V5	- 0.3	1.65	
T <sub>J</sub> operating junction temperature		- 40	150	°C
T <sub>stg</sub> storage temperature		- 55	150	°C

- (1) Operation outside the *Absolute Maximum Ratings* may cause permanent device damage. *Absolute Maximum Ratings* do not imply functional operation of the device at these or any other conditions beyond those listed under *Recommended Operating Conditions*. If used outside the *Recommended Operating Conditions* but within the *Absolute Maximum Ratings*, the device may not be fully functional, and this may affect device reliability, functionality, performance, and shorten the device lifetime.

### 5.2 ESD Ratings

			VALUE	UNIT
V <sub>(ESD)</sub>	Electrostatic discharge	Human-body model (HBM), per ANSI/ESDA/JEDEC JS-001 <sup>(1)</sup>	±2000	V
		Charged device model (CDM), per ANSI/ESDA/JEDEC JS-002 <sup>(2)</sup>	±1500	

- (1) JEDEC document JEP155 states that 500-V HBM allows safe manufacturing with a standard ESD control process.  
(2) JEDEC document JEP157 states that 250-V CDM allows safe manufacturing with a standard ESD control process.

### 5.3 Recommended Operating Conditions

over operating free-air temperature range (unless otherwise noted)

		MIN	NOM	MAX	UNIT
V <sub>AVIN</sub>	Controller input voltage with internal LDO	4.25	12	18	V
V <sub>AVIN</sub>	Controller input voltage with valid external bias applied to VDD5	2.95	12	18	V
V <sub>PVIN</sub>	Power stage input voltage with internal LDO	4.25	12	16	V
V <sub>PVIN</sub>	Power stage input voltage with valid external bias applied to VDD5	2.95	12	16	V
V <sub>OUT</sub>	Output voltage range	0.5		3.6	V
I <sub>OUT</sub> <sub>MAX(1 phase)</sub>	Maximum continuous output current for each phase			35	A
I <sub>OUT</sub> <sub>MAX(Total)</sub>	Maximum total continuous output current per module			70	A
Phase	Maximum number of stackable phases			4	
T <sub>J</sub>	Junction temperature	- 40		125	°C
T <sub>A</sub>	Ambient temperature	- 40		105	°C

## 5.4 Thermal Information

THERMAL METRIC <sup>(1)</sup>		QFM (MOW)	UNIT
		59 PINS	
$R_{\theta JA}$	Junction-to-ambient thermal resistance	12.6	°C/W
$\psi_{JT}$	Junction-to-top characterization parameter	0.78	°C/W
$\psi_{JB}$	Junction-to-board characterization parameter	9.8	°C/W

(1) For more information about traditional and new thermal metrics, see the [Semiconductor and IC Package Thermal Metrics](#) application report.

## 5.5 Electrical Characteristics

$T_J = -40^{\circ}\text{C}$  to  $125^{\circ}\text{C}$ ,  $V_{PVIN} = V_{AVIN} = 12\text{ V}$ ,  $f_{SW} = 550\text{ kHz}$ ; zero power dissipation (unless otherwise noted)

PARAMETER		TEST CONDITIONS		MIN	TYP	MAX	UNIT
<b>INPUT SUPPLY</b>							
$V_{AVIN}$	Input supply voltage range	Controller input voltage with internal LDO		4.25		18	V
$V_{AVIN}$	Input supply voltage range	Controller input voltage with valid external bias		2.95		18	
$V_{PVIN}$	Power stage voltage range	Power stage input voltage with internal LDO		4.25		16	
$V_{PVIN}$	Power stage voltage range	Power stage input voltage with valid external bias		2.95		16	
$I_{AVIN}$	Input operating current	Converter not switching, each phase			12.5	17	mA
<b>AVIN UVLO</b>							
$V_{AVINUVLO}$	Analog input voltage UVLO for power on reset (PMBus communication)	Enable threshold			2.5	2.7	V
	Analog input voltage UVLO for disable			2.09	2.3		V
	Analog input voltage UVLO hysteresis				250		mV
$t_{\text{delay}(uvlo\_PMBus)}$	Delay from AVIN UVLO to PMBus ready to communicate	$AVIN = 3\text{ V}$			8		ms
<b>PVIN UVLO</b>							
$VIN\_ON$	Power input turn-on voltage	Factory default setting			2.75		V
		Programmable range		2.75		15.75	
		Resolution			0.25		
		Accuracy		- 5%		5%	
$VIN\_OFF$	Power input turn-off voltage	Factory default setting			2.5		V
		Programmable range		2.5		15.5	
		Resolution			0.25		
		Accuracy		- 5%		5%	
<b>ENABLE AND UVLO</b>							
$V_{ENUVLO}$	EN/UVLO voltage rising threshold				1.05	1.1	V
	EN/UVLO voltage falling threshold			0.9			
$V_{ENHYS}$	EN/UVLO voltage hysteresis	No external resistors on EN/UVLO			70		mV
$I_{ENHYS}$	EN/UVLO hysteresis current	$V_{EN/UVLO} = 1.1\text{ V}$		4.5	5.5	6.5	$\mu\text{ A}$
	EN/UVLO hysteresis current	$V_{EN/UVLO} = 0.9\text{ V}$			- 100	- 5	nA
<b>REMOTE SENSE AMPLIFIER</b>							
$Z_{RSA}$	Remote sense input impedance	VOSNS – GOSNS = 1 V	VOSNS to GOSNS	85	130	165	k $\Omega$

$T_J = -40^\circ\text{C to } 125^\circ\text{C}$ ,  $V_{PVIN} = V_{AVIN} = 12\text{ V}$ ,  $f_{SW} = 550\text{ kHz}$ ; zero power dissipation (unless otherwise noted)

PARAMETER		TEST CONDITIONS	MIN	TYP	MAX	UNIT
$V_{IRNG(GOSNS)}$	GOSNS input range for regulation accuracy <sup>(1)</sup>	$V_{OSNS} - GOSNS = 1\text{ V}$ , $V_{OUT\_SCALE\_LOOP} \leq 0.5$	-0.05		0.05	V
$V_{IRNG(VOSNS)}$	VOSNS input range for regulation accuracy <sup>(1)</sup>	$GOSNS = AGND$ , $V_{OUT\_SCALE\_LOOP} \leq 0.5$	-0.1		5.5	V
<b>REFERENCE VOLTAGE AND ERROR AMPLIFIER</b>						
$V_{REF}$	Reference voltage <sup>(1)</sup>	Default setting		0.4		V
		Reference voltage range <sup>(1)</sup>		0.25	0.75	V
		Reference voltage resolution <sup>(1)</sup>		$2^{-12}$		V
$V_{OUT(ACC)}$	Output voltage accuracy	$V_{OUT} = 1000\text{ mV}$	$-40^\circ\text{C} \leq T_J \leq 150^\circ\text{C}^{(2)}$	0.992	1.008	V
		$V_{OUT} = 500\text{ mV}$		0.492	0.508	V
		$V_{OUT} = 1500\text{ mV}$		1.490	1.510	V
		$V_{OUT} = 1000\text{ mV}$	$0^\circ\text{C} \leq T_J \leq 125^\circ\text{C}^{(2)}$	0.994	1.006	V
		$V_{OUT} = 500\text{ mV}$		0.494	0.506	V
		$V_{OUT} = 1500\text{ mV}$		1.492	1.508	V
		$V_{OUT} = 1000\text{ mV}$	$0^\circ\text{C} \leq T_J \leq 85^\circ\text{C}^{(2)}$	0.995	1.005	V
		$V_{OUT} = 500\text{ mV}$		0.495	0.505	V
		$V_{OUT} = 1500\text{ mV}$		1.493	1.507	V
$G_{mEA}$	Programmable error amplifier transconductance		25		200	$\mu\text{S}$
	Resolution <sup>(1)</sup>	Four settings: 25 $\mu\text{S}$ , 50 $\mu\text{S}$ , 100 $\mu\text{S}$ , 200 $\mu\text{S}$		25		
	Unloaded bandwidth <sup>(1)</sup>			8		MHz
$R_{pEA}$	Programmable parallel resistor range		5		315	k $\Omega$
	Resolution <sup>(1)</sup>			5		
$C_{intEA}$	Programmable integrator capacitor range		1.25		18.75	pF
	Resolution <sup>(1)</sup>			1.25		pF
$C_{pEA}$	Programmable parallel capacitor range		6.25		193.75	pF
	Resolution <sup>(1)</sup>			6.25		
<b>CURRENT GM AMPLIFIER</b>						
$G_{mBUF}$	Programmable current error amplifier transconductance		25		200	$\mu\text{S}$
	Resolution <sup>(1)</sup>	Four settings: 25 $\mu\text{S}$ , 50 $\mu\text{S}$ , 100 $\mu\text{S}$ , 200 $\mu\text{S}$		25		
	Unloaded bandwidth <sup>(1)</sup>			17		MHz
$R_{pBUF}$	Programmable parallel resistor range		5		315	k $\Omega$
	Resolution <sup>(1)</sup>			5		
$R_{intBUF}$	Programmable integrator resistor range <sup>(1)</sup>		800		1600	k $\Omega$
	Resolution <sup>(1)</sup>			800		
$C_{intBUF}$	Programmable integrator capacitor range		0.3125		4.6875	pF
	Resolution <sup>(1)</sup>			0.3125		
$C_{pBUF}$	Programmable parallel capacitor range		3.125		96.875	pF
	Resolution <sup>(1)</sup>			3.125		
<b>OSCILLATOR</b>						

$T_J = -40^{\circ}\text{C to } 125^{\circ}\text{C}$ ,  $V_{PVIN} = V_{AVIN} = 12\text{ V}$ ,  $f_{SW} = 550\text{ kHz}$ ; zero power dissipation (unless otherwise noted)

PARAMETER		TEST CONDITIONS		MIN	TYP	MAX	UNIT
$f_{SW}$	Adjustment range <sup>(2)</sup>			275		1100	kHz
	Switching frequency <sup>(2)</sup>			500	550	600	
<b>SYNCHRONIZATION</b>							
$V_{IH(sync)}$	High-level input voltage			1.35			V
$V_{IL(sync)}$	Low-level input voltage					0.8	
$t_{pw(sync)}$	Sync input minimum pulse width					200	ns
$\Delta f_{SYNC}$	SYNC pin frequency range from FREQUENCY_SWITCH frequency <sup>(1)</sup>			- 20%		20%	
$V_{OH(sync)}$	Sync output high voltage	100- $\mu$ A load		VDD5 - 0.85V		VDD5	V
$V_{OL(sync)}$	Sync output low voltage	2.4-mA load				0.4	V
$t_{PLL}$	PLL lock time	$f_{sw} = 550\text{ kHz}$ , SYNC clock frequency 495 kHz - 605 kHz <sup>(1)</sup>				65	$\mu$ s
PhaseErr	Phase interleaving error <sup>(5)</sup>	$f_{sw} < 1.1\text{ MHz}$				9	Degree
		$f_{sw} \geq 1.1\text{ MHz}$				23	ns
<b>RESET</b>							
$V_{IH(reset)}$	High-level input voltage <sup>(1)</sup>			1.35			V
$V_{IL(reset)}$	Low-level input voltage					0.8	
$t_{pw(reset)}$	Minimum RESET_B pulse width					200	ns
$R_{pullup(reset)}$	Internal pullup resistance	$V_{RESET} = 0.8\text{ V}$	RESET# = 1	25	34	55	k $\Omega$
$V_{pullup(reset)}$	Internal pullup voltage	$I_{RESET} = 10\ \mu\text{ A}$	RESET# = 1			VDD5 - 0.5	V
<b>VDD5 REGULATOR</b>							
$V_{VDD5}$	Regulator output voltage	Default, $I_{VDD5} = 10\text{ mA}$		4.5	4.7	4.9	V
	Programmable range <sup>(1)</sup>			3.9		5.3	V
	Resolution				200		mV
$V_{VDD5(do)}$	Regulator dropout voltage	$V_{AVIN} - V_{VDD5}$ , $V_{AVIN} = 4.5\text{ V}$ , $I_{VDD5} = 25\text{ mA}$			130	285	mV
$I_{VDD5SC}$	Regulator short-circuit current <sup>(1)</sup>	$V_{AVIN} = 4.5\text{ V}$		100			mA
$V_{VDD5ON(IF)}$	Enable voltage on VDD5 for pin-strapping				2.62	2.85	V
$V_{VDD5OFF(IF)}$	Disable voltage on VDD5 for pin-strapping			2.25	2.48		V
$V_{VDD5ON(SW)}$	Switching enable voltage upon VDD5					4.05	V
$V_{VDD5OFF(SW)}$	Switching disable voltage upon VDD5			3.10			V
$V_{VDD5UV(hyst)}$	Regulator UVLO voltage hysteresis			400			mV
$V_{BOOT(drop)}$	Bootstrap voltage drop	$I_{BOOT} = 20\text{ mA}$ , $V_{VDD5} = 4.5\text{ V}$				225	mV
<b>BP1V5 REGULATOR</b>							
$V_{BP1V5}$	1.5-V regulator output voltage	$V_{AVIN} \geq 4.5\text{ V}$ , $I_{BP1V5} = 5\text{ mA}$		1.42	1.5	1.58	V
$I_{BP1V5SC}$	1.5-V regulator short-circuit current <sup>(1)</sup>			30			mA
<b>PWM</b>							



$T_J = -40^{\circ}\text{C}$  to  $125^{\circ}\text{C}$ ,  $V_{PVIN} = V_{AVIN} = 12\text{ V}$ ,  $f_{SW} = 550\text{ kHz}$ ; zero power dissipation (unless otherwise noted)

PARAMETER		TEST CONDITIONS	MIN	TYP	MAX	UNIT
$t_{ON(min)}$	Minimum controllable pulse width <sup>(1)</sup>				20	ns
$t_{OFF(min)}$	PWM Minimum off time <sup>(1)</sup>			400	500	ns
<b>SOFT START</b>						
$t_{ON\_RISE}$	Soft-start time	Factory default setting		3		ms
		Programmable range <sup>(1) (3)</sup>	0		31.75	
		Resolution		0.25		
		Accuracy, $T_{ON\_RISE} = 3\text{ ms}$	- 10%		15%	
$t_{ON\_MAX\_FLT\_LT}$	Upper limit on the time to power up the output	Factory default setting <sup>(4)</sup>		0		ms
		Programmable range <sup>(1) (4)</sup>	0		127.5	
		Resolution		0.5		
		Accuracy <sup>(1)</sup>	- 10%		15%	
$t_{ON\_DELAY}$	Turn-on delay	Factory default setting		0		ms
		Programmable range <sup>(1)</sup>	0		127.5	
		Resolution		0.5		
		Accuracy <sup>(1)</sup>	- 10%		15%	
<b>SOFT STOP</b>						
$t_{OFF\_FALL}$	Soft-stop time	Factory default setting <sup>(3)</sup>		0.5		ms
		Programmable range <sup>(1) (3)</sup>	0		31.75	
		Resolution		0.25		
		Accuracy, $t_{OFF\_FALL} = 1\text{ ms}$	- 10%		15%	
$t_{OFF\_DELAY}$	Turn-off delay	Factory default setting		0		ms
		Programmable range <sup>(1)</sup>	0		127.5	
		Resolution		0.5		
		Accuracy <sup>(1)</sup>	- 10%		15%	
<b>POWER INPUT OVERVOLTAGE/UNDERVOLTAGE</b>						
$V_{PVINOVF}$	Power input overvoltage fault limit	Factory default		20		V
		Programmable range	6		20	
		Resolution		1		
$V_{PVINUUVW}$	Power input undervoltage warning limit	Factory default		2.5		V
		Programmable range	2.5		15.75	
		Resolution		0.25		
<b>POWER STAGE</b>						
$R_{HS}$	High-side power device on-resistance	$V_{BOOT} - V_{SW} = 4.5\text{ V}$ , $T_J = 25^{\circ}\text{C}$		4.5		$\text{m}\Omega$
$R_{LS}$	Low-side power device on-resistance	$V_{VDD5} = 4.5\text{ V}$ , $T_J = 25^{\circ}\text{C}$		0.9		$\text{m}\Omega$
$R_{SWpd}$	SW internal pulldown resistance		3	30	35	$\text{k}\Omega$
$V_{wkdr(on)}$	Weak high-side gate drive triggering threshold upon PVIN rising			14.75		V
$V_{wkdr(off)}$	Weak high-side gate drive recovering threshold upon PVIN falling			14.35		V
$t_{DEAD(LtoH)}$	Power stage driver dead-time from low-side off to high-side on	$V_{VDD5} = 4.5\text{ V}$ , $T_J = 25^{\circ}\text{C}$ <sup>(1)</sup>		6		ns

$T_J = -40^\circ\text{C}$  to  $125^\circ\text{C}$ ,  $V_{PVIN} = V_{AVIN} = 12\text{ V}$ ,  $f_{SW} = 550\text{ kHz}$ ; zero power dissipation (unless otherwise noted)

PARAMETER		TEST CONDITIONS	MIN	TYP	MAX	UNIT
$t_{\text{DEAD(HtoL)}}$	Power stage driver dead-time from high-side off to low-side on	$V_{\text{VDD5}} = 4.5\text{ V}$ , $T_J = 25^\circ\text{C}^{(1)}$		6		ns
<b>CURRENT SHARING</b>						
$I_{\text{SHARE(acc)}}$	Output current sharing accuracy of two devices defined as the ratio of the current difference between two devices to the sum of the two	$I_{\text{OUT}} \geq 20\text{ A}$ per device <sup>(5)</sup>	- 10%		10%	
	Output current sharing accuracy of two devices defined as the current difference between each device and the average of all devices	$I_{\text{OUT}} < 20\text{ A}$ per device <sup>(5)</sup>	- 2		2	A
Output current sharing accuracy of two devices defined as the current difference between each device and the average of all devices		$I_{\text{OUT}} < 10\text{ A}$ per device <sup>(5)</sup>	- 1	1	A	
$V_{\text{SHARE}}$	VSHARE fault trip threshold			0.1		V
	VSHARE fault release threshold			0.2		
<b>LOW-SIDE CURRENT LIMIT PROTECTION</b>						
$t_{\text{OFF(OC)}}$	Off time between restart attempts <sup>(1)</sup>	Factory default setting		$7 \times t_{\text{ON\_RISE}}$		ms
	Range			$1 \times t_{\text{ON\_RISE}}$	$7 \times t_{\text{ON\_RISE}}$	
IO_OC_FLT_L MT	Output current overcurrent fault threshold	Factory default setting		52		A
		Programmable range		8	62	
		Resolution		2		
$I_{\text{NEGOC}}$	Negative output current overcurrent protection threshold			- 20		
IO_OC_WRN_L MT	Output current overcurrent warning threshold	Factory default setting		40		A
		Programmable range		8	62	
		Resolution		2		
$I_{\text{OC(acc)}}$	Output current overcurrent fault error	$I_{\text{OUT}} = 20\text{ A}$	- 2		4	A
		$I_{\text{OUT}} = 35\text{ A}^{(5)}$	- 4		8	
$I_{\text{HSOC}}$	Output current overcurrent fault accuracy	$I_{\text{OUT}} = 10\text{ A}$	- 1		2	A
		$I_{\text{OUT}} = 20\text{ A}^{(5)}$	- 2		4	
<b>HIGH-SIDE SHORT CIRCUIT PROTECTION</b>						
$I_{\text{HSOC}}$	Ratio of high-side short-circuit protection fault threshold over low-side overcurrent limit	$T_J = 25^\circ\text{C}^{(5)}$	105%	150%	200%	
	High-side current sense blanking time			100		ns
<b>POWER GOOD (PGOOD) AND OVERVOLTAGE/UNDERVOLTAGE WARNING</b>						

$T_J = -40^{\circ}\text{C}$  to  $125^{\circ}\text{C}$ ,  $V_{PVIN} = V_{AVIN} = 12\text{ V}$ ,  $f_{\text{SW}} = 550\text{ kHz}$ ; zero power dissipation (unless otherwise noted)

PARAMETER		TEST CONDITIONS	MIN	TYP	MAX	UNIT
$R_{\text{PGD}}$	PGD pulldown resistance	$I_{\text{PGD}} = 5\text{ mA}$		30	50	$\Omega$
$I_{\text{PGD(OH)}}$	Output high open drain leakage current into PGD pin	$V_{\text{PGD}} = 5\text{ V}$			15	$\mu\text{A}$
$V_{\text{PGD(OL)}}$	PGD pin output low level voltage at no supply voltage	$V_{\text{AVIN}} = 0$ , $I_{\text{PGD}} = 80\ \mu\text{A}$			0.8	V
$V_{\text{OVW}}$	Overvoltage warning threshold (PGD threshold on VOSNS rising)	Factory default, at $V_{\text{OUT\_COMMAND}} (\text{VOC}) = 1\text{ V}$	106%	110%	114%	VOC
	Range		103%		116%	
	Resolution			1%		
$V_{\text{UVW}}$	Undervoltage warning threshold (PGD threshold on VOSNS falling)	Factory default, at $V_{\text{OUT\_COMMAND}} (\text{VOC}) = 1\text{ V}$	86%	90%	94%	
	Range		84%		97%	
	Resolution			1%		
$V_{\text{PGD(rise)}}$	PGD release threshold on VOSNS rising and undervoltage warning de-assertion threshold	Factory default, at $V_{\text{OUT\_COMMAND}} (\text{VOC}) = 1\text{ V}$		95%		
$V_{\text{PGD(fall)}}$	PGD threshold on VOSNS falling and overvoltage warning de-assertion threshold	Factory default, at $V_{\text{OUT\_COMMAND}} (\text{VOC}) = 1\text{ V}$		105%		

**OUTPUT OVERVOLTAGE AND UNDERVOLTAGE FAULT PROTECTION**

$V_{\text{OVF}}$	Overvoltage fault threshold	Factory default, at $V_{\text{OUT\_COMMAND}} (\text{VOC}) = 1\text{ V}$	Factory default, at $V_{\text{OUT\_COMMAND}} (\text{VOC}) = 1\text{ V}$	111%	115%	119%	VOC
	Range	Factory default, at $V_{\text{OUT\_COMMAND}} (\text{VOC}) = 1\text{ V}$	Factory default, at $V_{\text{OUT\_COMMAND}} (\text{VOC}) = 1\text{ V}$	105%		140%	
	Resolution	Factory default, at $V_{\text{OUT\_COMMAND}} (\text{VOC}) = 1\text{ V}$	Factory default, at $V_{\text{OUT\_COMMAND}} (\text{VOC}) = 1\text{ V}$		2.5%		
$V_{\text{UVF}}$	Undervoltage fault threshold	Factory default, at $V_{\text{OUT\_COMMAND}} (\text{VOC}) = 1\text{ V}$	Factory default, at $V_{\text{OUT\_COMMAND}} = 1.00\text{ V}$	81%	85%	89%	
	Range	Factory default, at $V_{\text{OUT\_COMMAND}} = 1.00\text{ V}$	Factory default, at $V_{\text{OUT\_COMMAND}} = 1.00\text{ V}$	60%		95%	
	Resolution	Factory default, at $V_{\text{OUT\_COMMAND}} = 1.00\text{ V}$	Factory default, at $V_{\text{OUT\_COMMAND}} = 1.00\text{ V}$		2.5%		
$V_{\text{UVF(max)}}$	Undervoltage fault threshold maximum setting			91%	95%	99%	VOC
$V_{\text{OVF(fix)OFF}}$	Fixed overvoltage fault threshold	Factory default, at $V_{\text{OUT\_COMMAND}} (\text{VOC}) = 1\text{ V}$	Factory default, at $V_{\text{OUT\_COMMAND}} = 1.00\text{ V}$	1.15	1.2	1.25	V
	Recovery threshold <sup>(1)</sup>	Factory default, at $V_{\text{OUT\_COMMAND}} = 1.00\text{ V}$	Factory default, at $V_{\text{OUT\_COMMAND}} = 1.00\text{ V}$		0.4		

**OUTPUT VOLTAGE TRIMMING**

$V_{\text{OUTRES}}$	Default resolution of $V_{\text{OUT\_COMMAND}}$ , trim and margin, $V_{\text{OUT\_SCALE\_LOOP}} = 0.5$	1.90	1.95	2.00	mV
	Programmable range <sup>(1)</sup>	$2^{-12}$		$2^{-5}$	V

$T_J = -40^{\circ}\text{C}$  to  $125^{\circ}\text{C}$ ,  $V_{PVIN} = V_{AVIN} = 12\text{ V}$ ,  $f_{SW} = 550\text{ kHz}$ ; zero power dissipation (unless otherwise noted)

PARAMETER		TEST CONDITIONS		MIN	TYP	MAX	UNIT
VOUT_TRAN_RT	Output voltage transition rate	Factory default setting			1		mV/ $\mu\text{s}$
		Programmable range <sup>(1)</sup>		0.063		15.933	
		Accuracy		- 10%		10%	
VOUT_TRAN_RT	Output voltage transition rate	16-mV/ $\mu\text{s}$ program rate		14.4	16	17.6	mV/ $\mu\text{s}$
VOUT_SCL_LP	Feedback loop scaling factor <sup>(1)</sup>	Factory default setting			0.5		
		Programmable range, four discrete settings		0.125		1	
VOUT_CMD	Output voltage programmable values	Factory default setting			0.8		V
		Programmable range	VOUT_SCALE_LOOP = 1 <sup>(5)</sup>	0.25		0.75	V
			VOUT_SCALE_LOOP = 0.5	0.25		1.5	
			VOUT_SCALE_LOOP = 0.25 <sup>(5)</sup>	0.25		3	
			VOUT_SCALE_LOOP = 0.125 <sup>(5)</sup>	0.25		3.6	
VOUT_CMD	Output voltage accuracy	Maximum output voltage	VOUT_SCALE_LOOP = 1	0.742	0.750	0.758	V
<b>TEMPERATURE SENSE AND THERMAL SHUTDOWN</b>							
T <sub>SD</sub>	Bandgap thermal shutdown temperature <sup>(1)</sup>			150	170		°C
T <sub>HYST</sub>	Bandgap thermal shutdown hysteresis <sup>(1)</sup>					25	
OT_FLT_LMT	Internal overtemperature fault limit <sup>(1)</sup>	Factory default setting			150		
		Programmable range		0		160	
		Resolution			1		
OT_WRN_LMT	Internal overtemperature warning limit <sup>(1)</sup>	Factory default setting			125		
		Programmable range		0		160	
		Resolution			1		
T <sub>OT(hys)</sub>	Internal overtemperature fault, warning hysteresis <sup>(1)</sup>					25	
<b>MEASUREMENT SYSTEM</b>							
M <sub>VOUT(rng)</sub>	Output voltage measurement range <sup>(1)</sup>			0		6	V
M <sub>VOUT(acc)</sub>	Output voltage measurement accuracy	250 mV < V <sub>OUT</sub> < 6 V		- 2%		2%	
M <sub>VOUT(acc)</sub>	Output voltage measurement accuracy	0.5 V < V <sub>OUT</sub> < 1.25 V	VOUT_SCALE_LOOP = 0.5	- 1%		1%	
M <sub>VOUT(lsb)</sub>	Output voltage measurement bit resolution <sup>(1)</sup>				244		$\mu\text{V}$
M <sub>IOUT(rng)</sub>	Output current measurement range <sup>(1)</sup>			- 10		60	A
M <sub>IOUT(acc)</sub>	Output current measurement accuracy <sup>(5)</sup>	I <sub>OUT</sub> ≤ 10 A, T <sub>J</sub> = 25°C		- 1.8	0	1.8	A
M <sub>IOUT(acc)</sub>	Output current measurement accuracy <sup>(5)</sup>	I <sub>OUT</sub> = 20 A, -40°C ≤ T <sub>J</sub> ≤ 150°C		- 3	0	3	A
M <sub>IOUT(acc)</sub>	Output current measurement accuracy <sup>(5)</sup>	I <sub>OUT</sub> = 35 A, -40°C ≤ T <sub>J</sub> ≤ 150°C		- 4	0	4	A
M <sub>IOUT(acc)</sub>	Output current measurement accuracy <sup>(5)</sup>	I <sub>OUT</sub> = 20 A, 0°C ≤ T <sub>J</sub> ≤ 85°C		- 2.5	0	2.5	A
M <sub>IOUT(acc)</sub>	Output current measurement accuracy <sup>(5)</sup>	I <sub>OUT</sub> = 35 A, 0°C ≤ T <sub>J</sub> ≤ 85°C		- 3	0	3	A

$T_J = -40^{\circ}\text{C}$  to  $125^{\circ}\text{C}$ ,  $V_{PVIN} = V_{AVIN} = 12\text{ V}$ ,  $f_{\text{SW}} = 550\text{ kHz}$ ; zero power dissipation (unless otherwise noted)

PARAMETER		TEST CONDITIONS	MIN	TYP	MAX	UNIT
$M_{I\text{OUT}(\text{acc})}$	Output current measurement accuracy	$I_{\text{OUT}} = 5\text{ A}$	-1	0	1	A
		$I_{\text{OUT}} = 10\text{ A}$	-1.5	0	1.5	A
		$I_{\text{OUT}} = 20\text{ A}$	-2	0	2	A
$M_{I\text{OUT}(\text{lsb})}$	Output current measurement bit resolution <sup>(1)</sup>		2 <sup>-6</sup>			A
$M_{\text{PVIN}(\text{rng})}$	Input voltage measurement range <sup>(1)</sup>		0		20	V
$M_{\text{PVIN}(\text{acc})}$	Input voltage measurement accuracy	$4\text{ V} < \text{PVIN} < 20\text{ V}$	-3%		3%	
$M_{\text{PVIN}(\text{lsb})}$	Input voltage measurement bit resolution <sup>(1)</sup>		2 <sup>-6</sup>			V
$M_{\text{TSNS}(\text{acc})}$	Internal temperature sense accuracy <sup>(5)</sup>	$-40^{\circ}\text{C} \leq T_J \leq 150^{\circ}\text{C}$	-3		3	°C
$M_{\text{TSNS}(\text{lsb})}$	Internal temperature sense bit resolution <sup>(1)</sup>		0.25			
<b>PMBUS INTERFACE + BCX</b>						
$V_{\text{IH}(\text{PMBUS})}$	High-level input voltage on PMB_CLK, PMB_DATA, BCX_CLK, BCX_DAT		1.35			V
$V_{\text{IL}(\text{PMBUS})}$	Low-level input voltage on PMB_CLK, PMB_DATA, BCX_CLK, BCX_DAT				0.8	
$I_{\text{IH}(\text{PMBUS})}$	Input high level current into PMB_CLK, PMB_DATA		-10		10	μA
$I_{\text{IL}(\text{PMBUS})}$	Input low level current into PMB_CLK, PMB_DATA		-10		10	μA
$V_{\text{OL}(\text{PMBUS})}$	Output low level voltage on PMB_DATA, SMB_ALRT, BCX_DAT	$V_{\text{AVIN}} > 4.5\text{ V}$ , input current to PMB_DATA, SMB_ALRT, BCX_DAT = 20 mA			0.4	V
$I_{\text{OH}(\text{PMBUS})}$	Output high level open-drain leakage current into PMB_DATA, SMB_ALRT	Voltage on PMB_DATA, SMB_ALRT = 5.5 V			10	μA
$I_{\text{OL}(\text{PMBUS})}$	Output low level open-drain sinking current on PMB_DATA, SMB_ALRT, BCX_DAT	Voltage on PMB_DATA, SMB_ALRT, BCX_DAT = 0.4 V	20			mA
$f_{\text{PMBUS\_CLK}}$	PMBus operating frequency range	GOSNS = AGND	10		1000	kHz
$C_{\text{PMBUS}}$	PMBUS_CLK and PMBUS_DATA pin input capacitance <sup>(1)</sup>	$V_{\text{pin}} = 0.1\text{ V}$ to $1.35\text{ V}$			5	pF
$N_{\text{WR\_NVM}}$	Number of NVM writable cycles <sup>(1)</sup>	$-40^{\circ}\text{C}$ to $150^{\circ}\text{C}$	1000			cycle
$t_{\text{CLK\_STCH}(\text{max})}$	Maximum allowable clock stretch <sup>(1)</sup>				6	ms

(1) Specified by design; not production tested

(2) The parameter covers 2.95 V to 18 V of AVIN.

(3) The setting of  $t_{\text{ON\_RISE}}$  and  $t_{\text{OFF\_FALL}}$  of 0 ms means the unit brings its output voltage to the programmed regulation value of down to 0 as quickly as possible, which results in an effective  $t_{\text{ON\_RISE}}$  and  $t_{\text{OFF\_FALL}}$  time of 0.5 ms (fastest time supported).

(4) The setting of  $t_{\text{ON\_MAX\_FAULT\_LIMIT}}$  and  $t_{\text{OFF\_MAX\_WARN\_LIMIT}}$  of 0 means disabling  $t_{\text{ON\_MAX\_FAULT}}$  and  $t_{\text{OFF\_MAX\_WARN}}$  response and reporting completely.

(5) Not production tested

## 5.6 Typical Characteristics

$V_{PIN} = V_{AVIN} = 12\text{ V}$ ,  $T_A = 25^\circ\text{C}$ ,  $f_{sw} = 325\text{ kHz}$  for  $V_{OUT} = 0.5\text{ V}$  to  $0.8\text{ V}$ ,  $f_{sw} = 550\text{ kHz}$  for  $V_{OUT} = 1.0\text{ V}$  to  $1.5\text{ V}$

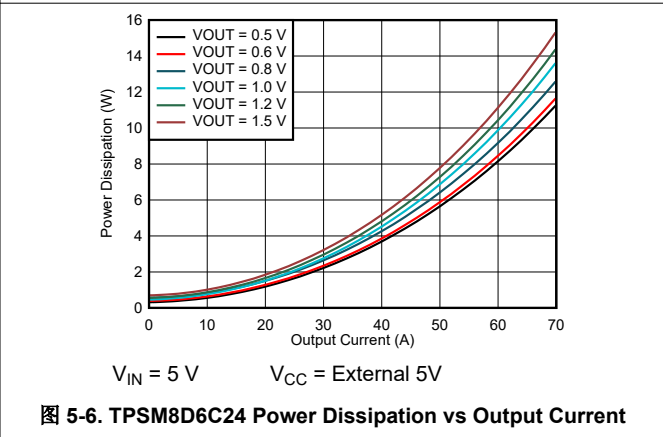
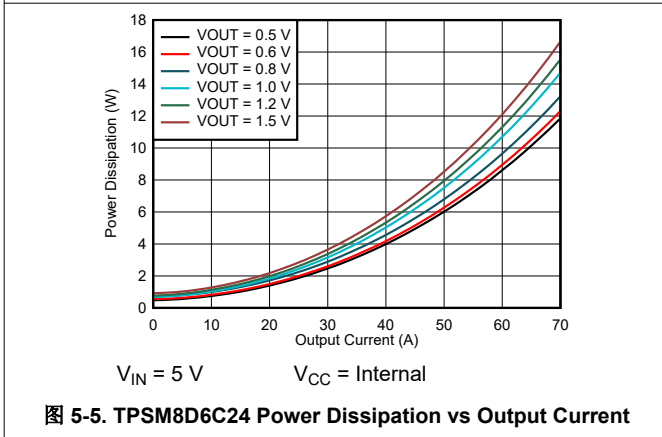
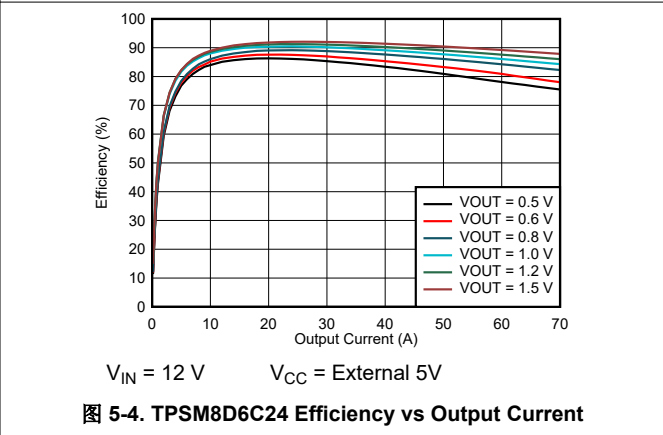
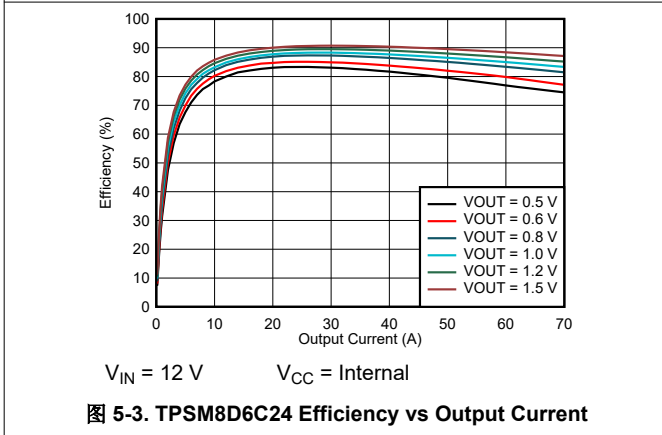
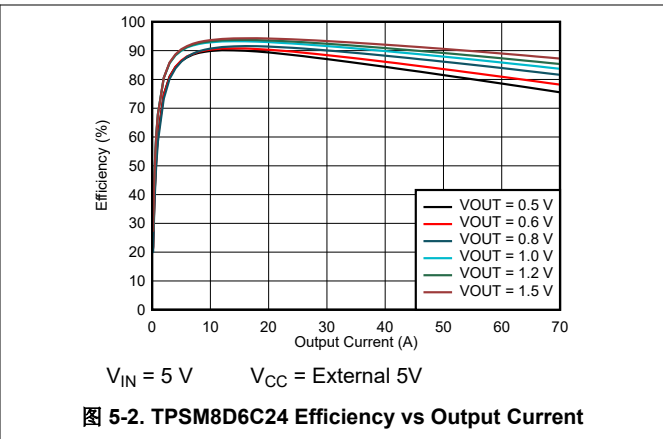
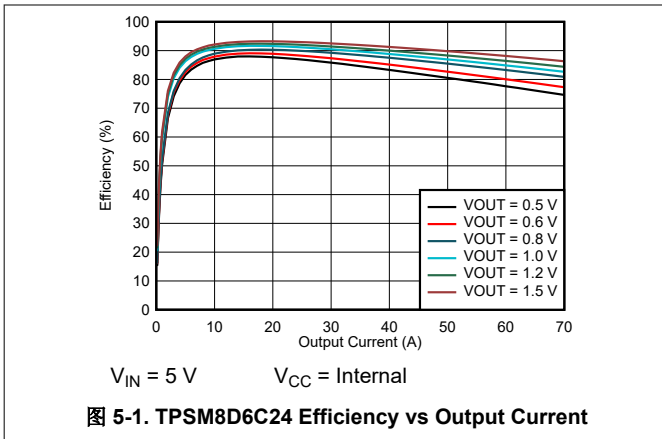

### 5.6 Typical Characteristics (continued)

$V_{PIN} = V_{AVIN} = 12\text{ V}$ ,  $T_A = 25^\circ\text{C}$ ,  $f_{sw} = 325\text{ kHz}$  for  $V_{OUT} = 0.5\text{ V}$  to  $0.8\text{ V}$ ,  $f_{sw} = 550\text{ kHz}$  for  $V_{OUT} = 1.0\text{ V}$  to  $1.5\text{ V}$

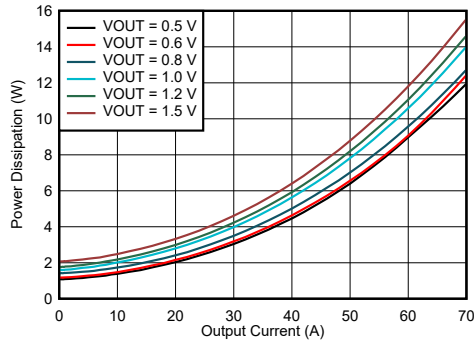

$V_{IN} = 12\text{ V}$        $V_{CC} = \text{Internal}$

图 5-7. TPSM8D6C24 Power Dissipation vs Output Current

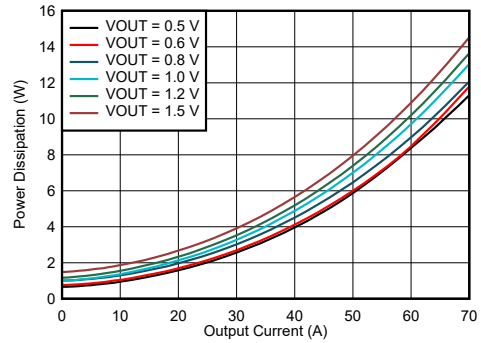

$V_{IN} = 12\text{ V}$        $V_{CC} = \text{External } 5\text{V}$

图 5-8. TPSM8D6C24 Power Dissipation vs Output Current

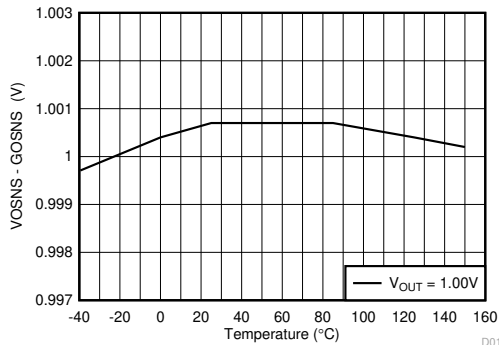

$V_{OUT\_COMMAND} = 1\text{ V}$

图 5-9. Output Voltage vs Junction Temperature



图 5-10. Switching Frequency vs Junction Temperature



图 5-11. Nonswitching Input Current ( $I_{AVIN}$ ) vs Junction Temperature

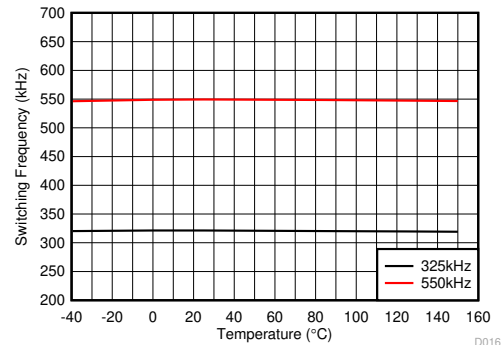

$I_{VDD5} = 10\text{ mA}$        $V_{PVIN} = V_{AVIN} = 12\text{ V}$

图 5-12. VDD5 Voltage vs Junction Temperature

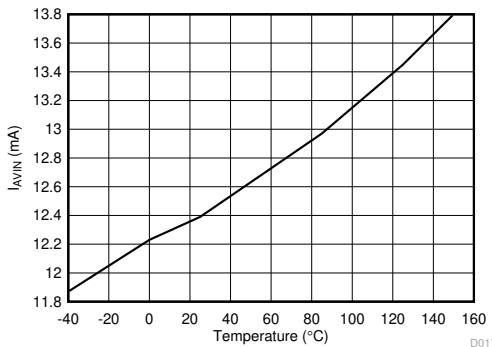
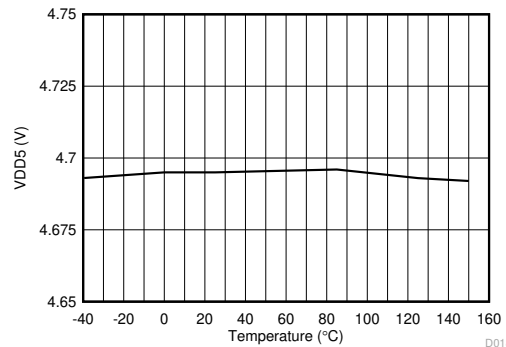
### 5.6 Typical Characteristics (continued)

$V_{PIN} = V_{AVIN} = 12\text{ V}$ ,  $T_A = 25^\circ\text{C}$ ,  $f_{sw} = 325\text{ kHz}$  for  $V_{OUT} = 0.5\text{ V}$  to  $0.8\text{ V}$ ,  $f_{sw} = 550\text{ kHz}$  for  $V_{OUT} = 1.0\text{ V}$  to  $1.5\text{ V}$



图 5-13. BP1V5 Voltage vs Junction Temperature



图 5-14. Turn-On Voltage vs Junction Temperature

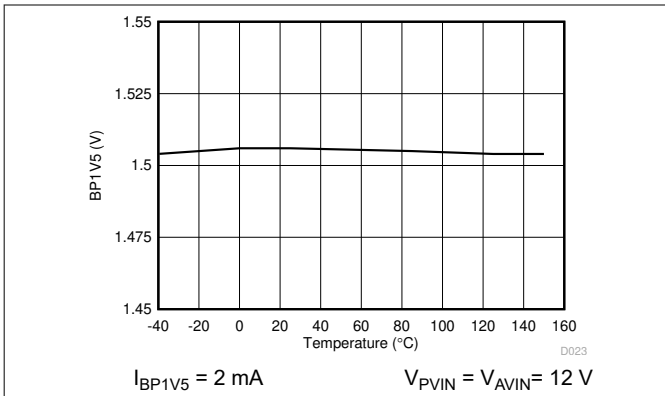

图 5-15. Turn-Off Voltage vs Junction Temperature



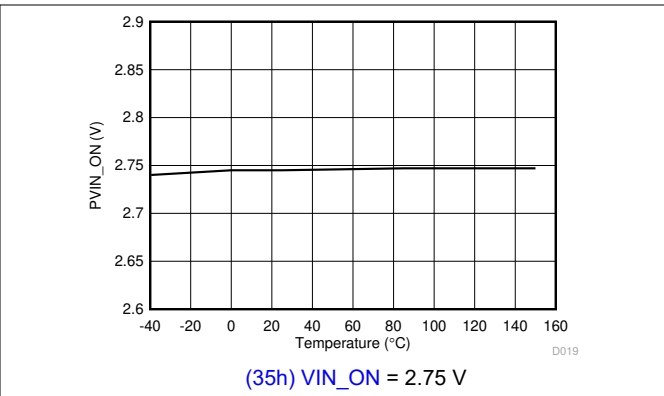

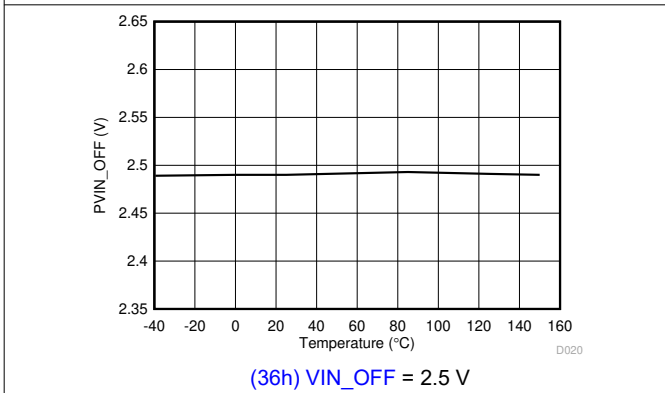
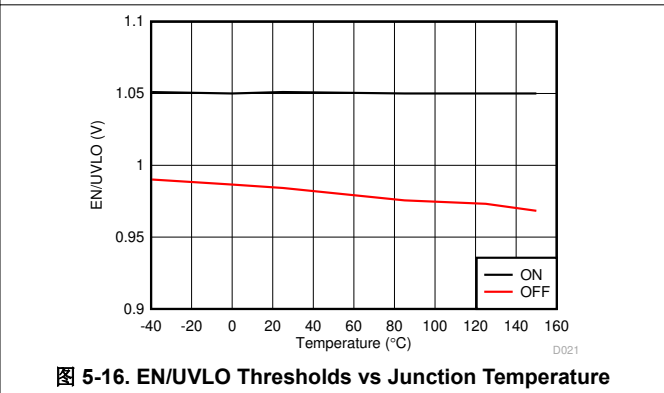

## 6.3 Feature Description

### 6.3.1 Average Current-Mode Control

The TPSM8D6C24 device uses an average current-mode control architecture with independently programmable current error integration and voltage error integration loops. This architecture provides similar performance to peak current-mode control without restricting the minimum on-time or minimum off-time control, allowing the gain selection of the current loop to effectively set the slope compensation. For help selecting compensation values, customers can use the [TPS546x24A Compensation and Pin-Strap Resistor Calculator](#) design tool.



图 6-1. Average Current Mode Control Block Diagram

#### 6.3.1.1 On-Time Modulator

The input voltage feedforward modulator converts the integrated current error signal,  $I_{Lerr}$ , into an inductor on time that provides a controlled volt-second balance across the inductor over each full switching period that simplifies the current error integration loop design. The modulator produces a full-cycle averaged small signal  $V_{cntrl}$  to  $di_L/dt$  transfer function given by 方程式 1:

$$\frac{di_L}{dt} = \frac{VIN}{Vramp} \times \frac{1}{L} = \frac{5.5}{L} \quad (1)$$

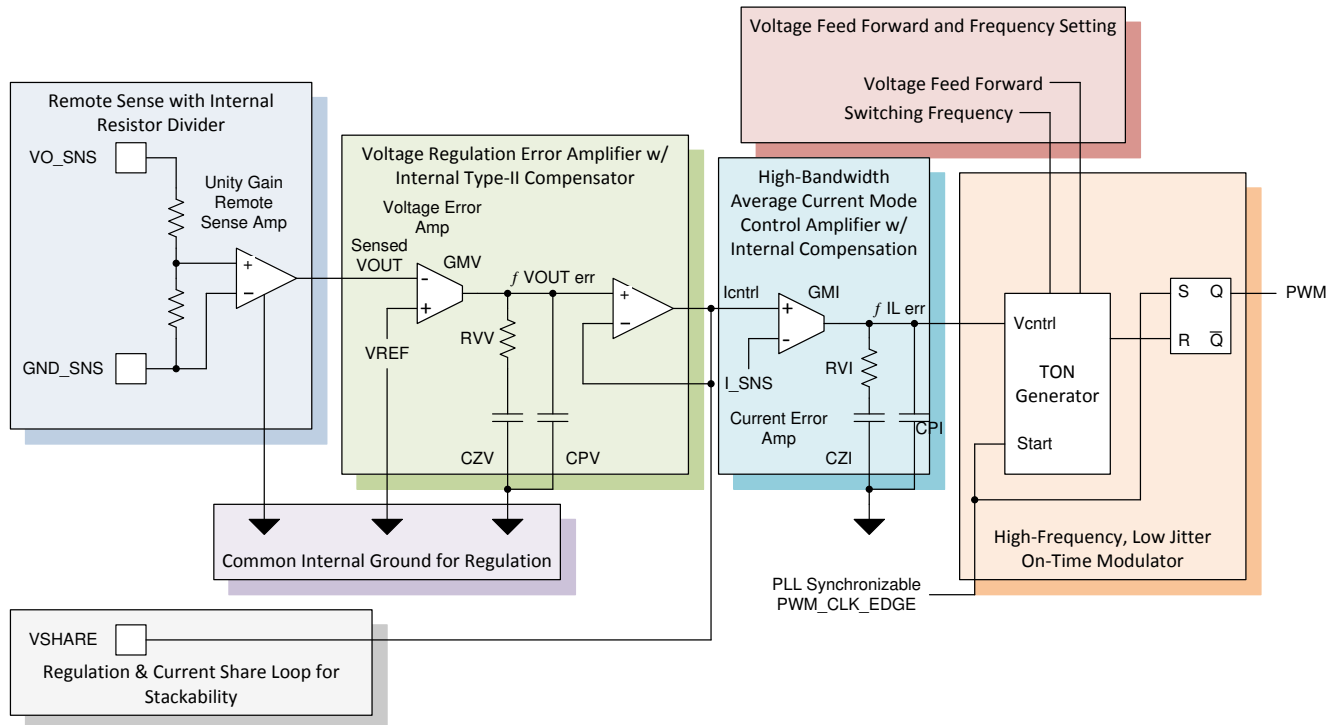
Thus, the inductor current modulator gain is given by 方程式 2:

$$\frac{di_L}{dV_{cntrl}}(f) = \frac{VIN}{Vramp} \times \frac{1}{L \times f} = \frac{5.5}{L \times f} \quad (2)$$

This natural integration  $1/f$  function allows the current loop to be compensated by the mid-band gain of the error current integrator. Use  $L = 0.22 \mu H$  for calculation.

### 6.3.1.2 Current Error Integrator

The current error integrator adjusts the modulator control voltage to match the sensed inductor current,  $I_{\text{SNS}}$ , to the current voltage at the VSHARE pin. The integrator is tuned through the following parameters in [\(B1h\) USER\\_DATA\\_01 \(COMPENSATION\\_CONFIG\)](#):

- GMI
- RVI
- CZI
- CPI
- CZI\_MUL

Due to the natural integration of the  $1/f$  function of the current control gain, the bandwidth of the current control loop can be adjusted with the mid-band gain of the integrator,  $\text{GMI} \times \text{RVI}$ .

The current loop crossover occurs at the frequency when the full loop gain is equal to 1 according to [方程式 3](#):

$$|\text{ILOOP}(f)| \times \frac{V_{\text{PVIN}}}{V_{\text{ramp}}} \times \text{CSA} \times \frac{1}{1.7 \times \pi \times f \times L} = 1 \quad (3)$$

Solving for the mid-band gain of the current loop, the user finds [方程式 4](#):

$$\text{ILOOP}_{\text{MB}} = \text{GMI} \times \text{RVI} = \frac{V_{\text{ramp}}}{V_{\text{PVIN}}} \times \frac{1.7}{\text{CSA}} \times L \times \pi \times f_{\text{coi}} \quad (4)$$

While the Nyquist Theorem suggests that a bandwidth of  $1/2 f_{\text{SW}}$  is possible, inductor tolerances and phase delays in the current sense, modulator, and H-bridge power FETs make  $f_{\text{SW}}/4$  a more practical target, which simplifies the target current loop mid-band gain to achieve a current loop bandwidth of  $f_{\text{SW}}/4$  to [方程式 5](#):

$$\text{ILOOP}_{\text{MB}} = \text{GMI} \times \text{RVI} = \frac{V_{\text{ramp}}}{V_{\text{PVIN}}} \times \frac{1.7}{\text{CSA}} \times L \times \pi \times \frac{f_{\text{sw}}}{4} = \frac{1.7 \times \pi}{4 \times 5.5 \times 6.155 \times 10^{-3}} \times L \times f_{\text{sw}} = 39.4 \times L \times f_{\text{sw}} \quad (5)$$

An integrator from DC to the low-frequency zero,  $\text{RVI} \times \text{CZI}$ , compensates for the valley voltage of the modulator ramp and the nominal offset of the output voltage. A high-frequency filter pole,  $\text{RVI} \times \text{CPI}$ , between half the switching frequency and the switching frequency reduces high-frequency noise from VSHARE and minimizes pulse-width jitter.

To avoid loop interactions, the integrating zero frequency must be below the voltage loop crossover frequency, while the high-frequency pole must be between  $1/2$  the switching frequency and the switching frequency to limit high-frequency noise and jitter in the current loop without imposing additional phase loss in the voltage loop.

The closed loop average current mode control allows the current sense amplifier, on-time modulator, H-bridge power FETs, and inductor to operate as a transconductance amplifier with forward gain of  $1/\text{CSA}$  or  $162.5 \text{ A/V}$  with a bandwidth equal to  $f_{\text{coi}}$ .

### 6.3.1.3 Voltage Error Integrator

The voltage error integrator regulates the output voltage by adjusting the current control voltage,  $V_{\text{SHARE}}$ , similar to any current mode control architecture. A transconductance amplifier compares the sense feedback voltage to a programmed reference voltage to set  $V_{\text{SHARE}}$  to maintain the desired output voltage. While a regulated current source feeding an output capacitance provides a natural, stable integrator, mid-band gain is often desired to improve the loop bandwidth and transient response.

With a transconductance set by the current sense gain, the voltage loop crossover occurs when the full loop gain equals 1 according to [方程式 6](#).

$$VOUT\_SCALE\_LOOP \times |VLOOP(f)| \times \frac{1}{CSA} \times |Z_{OUT}(f)| = 1 \quad (6)$$

To prevent the current integration loop bandwidth from negatively impacting the phase margin of the voltage loop, the voltage loop must have a target bandwidth of  $f_{coi} / 2.5$ . With a current mode loop of  $f_{sw} / 4$ , the voltage loop mid-band gain is [方程式 7](#):

$$VLOOP_{MB} = GMV \times RVV = \frac{1}{VOUT\_SCALE\_LOOP} \times \frac{CSA}{Z_{OUT}\left(\frac{f_{sw}}{10}\right)} \quad (7)$$

An integrator pole is necessary to maintain accurate DC regulation, and the zero-frequency set by  $RVV \times CZV$  must be set below the lowest crossover frequency with the largest output capacitor intended to be supported at the output, but not more than  $1 / 2$  the target voltage loop crossover frequency,  $f_{cov}$ .

A high frequency noise pole, intended to keep switching noise out of the current loop must also be employed, with a high-frequency pole set by  $RVV \times CPV$  must be set between  $f_{sw} / 4$  and  $f_{sw}$ .

For pin-programmed options of compensation components, see [表 6-9](#).

For PMBus programming of compensation values, see [\(B1h\) USER\\_DATA\\_01 \(COMPENSATION\\_CONFIG\)](#).

### 6.3.2 Linear Regulators

TPSM8D6C24 devices have three internal linear regulators receiving power from AVIN and providing suitable bias (1.5 V, 1.8 V, and 5 V) for the internal circuitry of the device. Once AVIN, 1.5 V, 1.8 V, and 5 V reach their respective UVLOs, the device initiates a power-on reset, after which, the device can be communicated with through PMBus for configuration and users can store defaults to the NVM.

VDD5 has an internally fixed undervoltage lockout of 3.9 V (typical) to enable power-stage conversion. The VDD5 regulator can also be fed by an external supply of 4.75 V to 5.25 V to reduce internal power dissipation and improve efficiency by eliminating the loss in the internal LDO, or to allow operation with AVIN less than 4 V. The external supply should be higher voltage than the LDO regulation voltage programmed by [\(B5h\) USER\\_DATA\\_05 \(POWER\\_STAGE\\_CONFIG\)](#).

The use of the internal regulators to power other circuits is not recommended because the loads placed on the regulators can adversely affect operation of the controller.

### 6.3.3 AVIN and PVIN Pins

The TPSM8D6C24 allows for a variety of applications by using the AVIN and PVIN pins together or separately. The AVIN pin voltage supplies the internal control circuits of the device. The PVIN pin voltage provides the input voltage to the switching power stage. When connected to a single supply, the input voltage for AVIN and PVIN can range from 4 V to 16 V. If the PVIN is connected to a separate supply from AVIN, the PVIN voltage can be 2.95 V to 16 V. If PVIN is connected to the same supply as AVIN, then AVIN has to meet a 4-V minimum and 16-V maximum to drive the controller and driver.

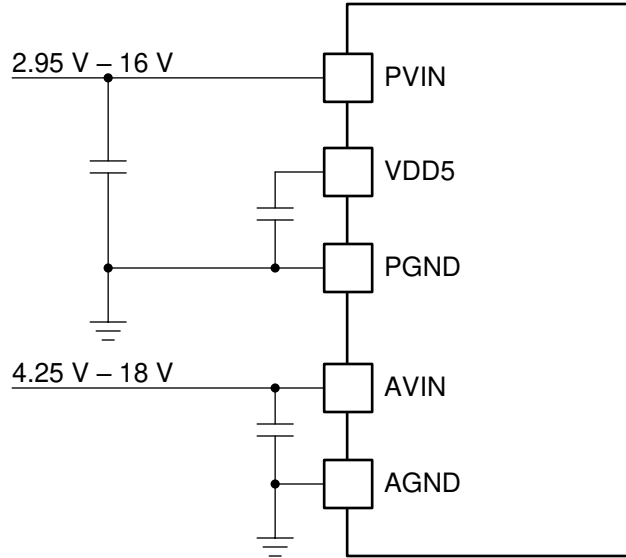

**图 6-2. TPSM8D6C24 Separate PVIN and AVIN Connections**

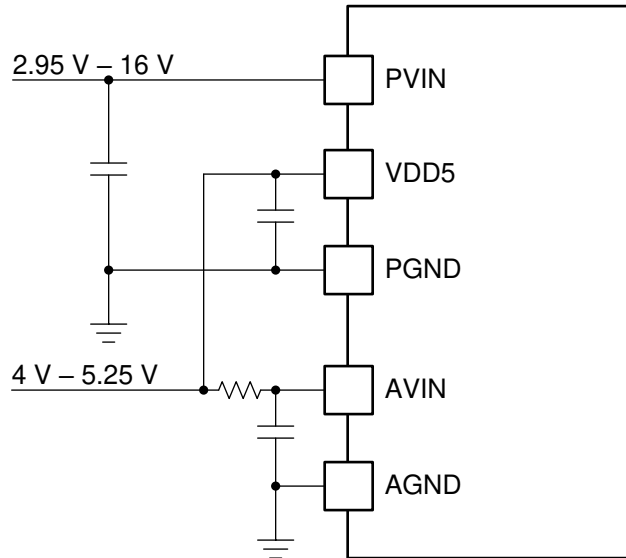

**图 6-3. TPSM8D6C24 Separate PVIN and AVIN Connections with VDD5**



图 6-4. TPSM8D6C24 Separate PVIN, AVIN, and VDD5 Connections

### 6.3.4 Input Undervoltage Lockout (UVLO)

The TPSM8D6C24 provides four independent UVLO functions for the broadest range of flexibility in start-up control. While only the fixed AVIN UVLO is required to enable PMBus connectivity as well as VOUT and TEMPERATURE monitoring, all four UVLO functions must be met before switching can be enabled.

#### 6.3.4.1 Fixed AVIN UVLO

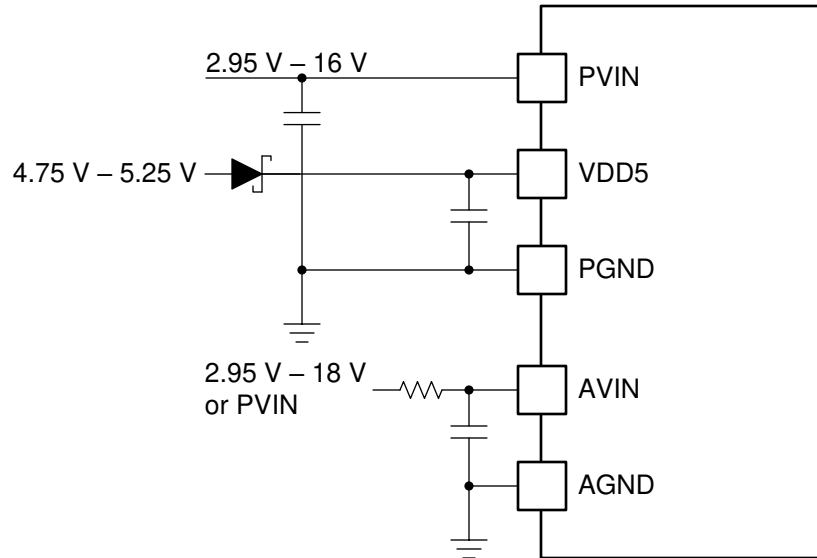
The TPSM8D6C24 has an internally fixed UVLO of 2.5 V (typical) on AVIN to enable the digital core and initiate power-on reset, including pin detection. The off-threshold on AVIN is 2.3 V (typical).

#### 6.3.4.2 Fixed VDD5 UVLO

The TPSM8D6C24 has an internally fixed UVLO of 3.9 V (typical) on VDD5 to enable drivers and output voltage conversion. The off-threshold on VDD5 is 3.5 V.

#### 6.3.4.3 Programmable PVIN UVLO

Two PMBus commands ((35h) *VIN\_ON* and (36h) *VIN\_OFF*) allow the user to set PVIN voltage turn-on and turn-off thresholds independently with 0.25-V resolution from 2.75 V to 15.75 V (6-bit) for (35h) *VIN\_ON* and from 2.5 V to 15.5 V (6-bit) for (36h) *VIN\_OFF*.

#### 备注

If (36h) *VIN\_OFF* is programmed higher than (35h) *VIN\_ON*, the TPSM8D6C24 rapidly switches between enabled and disabled while PVIN remains below (36h) *VIN\_OFF*. Propagation delays between enable and disable can result in the converter starting (61h) *TON\_RISE* and (65h) *TOFF\_FALL* in such conditions.

#### 6.3.4.4 EN/UVLO Pin

The TPSM8D6C24 also offers a precise threshold and hysteresis current source on the EN/UVLO pin so that it can be used to program an additional UVLO to any external voltage greater than 1.05 V (typical), including AVIN, PVIN, or VDD5. For an added level of flexibility, the EN/UVLO pin can be disabled or its logic inverted through the PMBUS command (02h) *ON\_OFF\_CONFIG*, which allows the pin to be connected to AGND to make sure the output is not enabled until PMBus programming has been completed.



图 6-5. TPSM8D6C24 UVLO Voltage Divider

### 6.3.5 Start-Up and Shutdown

The start-up and shutdown of the device is controlled by several PMBus programmable values including:

- (01h) OPERATION
- (02h) ON\_OFF\_CONFIG
- (60h) TON\_DELAY
- (61h) TON\_RISE
- (64h) TOFF\_DELAY
- (65h) TOFF\_FALL

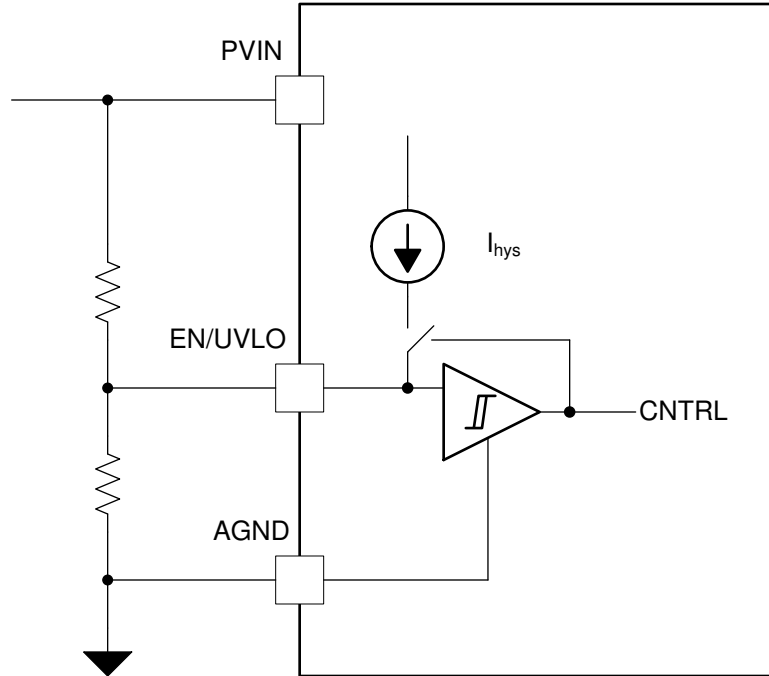
With the default (02h) ON\_OFF\_CONFIG settings, the timing is as shown in 图 6-6. See the [Supported PMBus Commands](#) section for full details on the implementation.



图 6-6. TPSM8D6C24 Start-Up and Shutdown

## 备注

The TPSM8D6C24 requires time between the AVIN and VDD5 reaching their UVLO levels for pin-detection and PMBus communication and valid sensing of EN/UVLO and PVIN\_OK. Once AVIN and VDD5 exceed their lower UVLO thresholds (2.9-V typical), the TPSM8D6C24 starts its power-on-reset, self-calibration, and pin-detection. This time delay,  $t_{\text{delay}(uvlo\_PMBus)}$  (6-ms typical), must be complete before PVIN\_OK or EN/UVLO sensing is enabled.

If VDD5<sub>PS\_ON</sub>, PVIN\_OK, and EN/UVLO are above their thresholds before the end of  $t_{\text{delay}(uvlo\_PMBus)}$ , (60h) **TON\_DELAY** starts after  $t_{\text{delay}(uvlo\_PMBus)}$  completes.

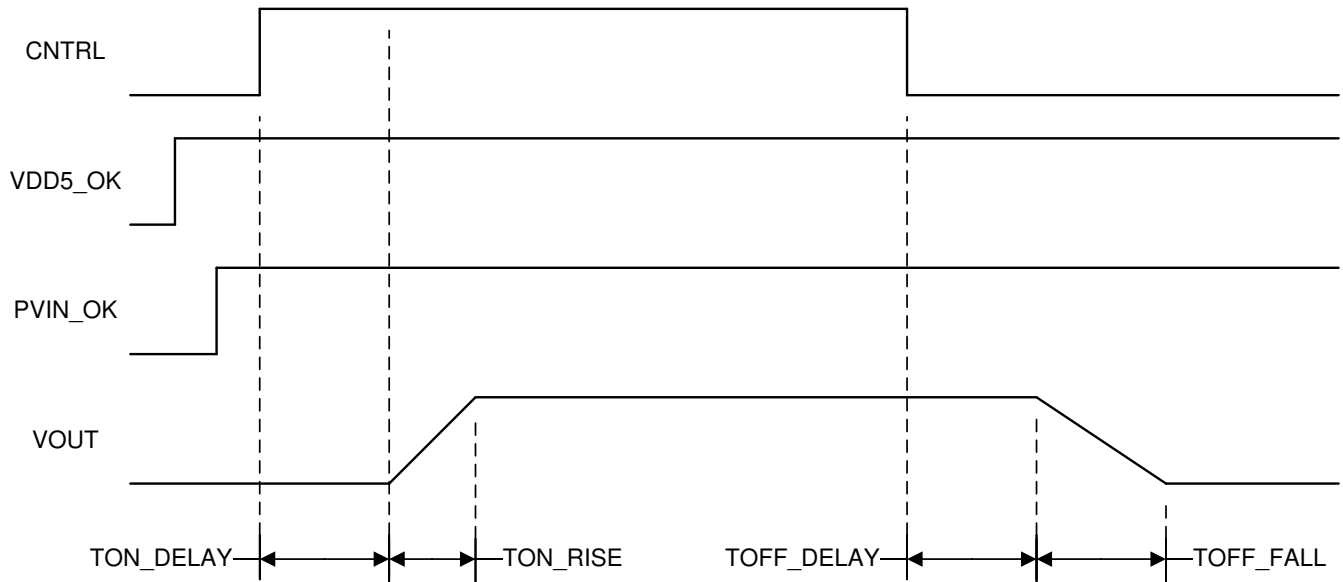
If VDD5<sub>PS\_ON</sub>, PVIN\_OK, or EN/UVLO are below their thresholds when  $t_{\text{delay}(uvlo\_PMBus)}$  completes, (60h) **TON\_DELAY** starts when VDD5\_OK, PVIN\_OK, and EN/UVLO are all above their thresholds.

### 6.3.6 Differential Sense Amplifier and Feedback Divider

The TPSM8D6C24 includes a fully integrated, internal, precision feedback divider and remote sense. Using both the selectable feedback divider and precision adjustable reference, output voltages up to 6.0 V can be obtained. The feedback divider can be programmed to divider ratios of 1:1, 1:2, 1:4, or 1:8 using the (29h) **VOUT\_SCALE\_LOOP** command.

The recommended operating range of (21h) **VOUT\_COMMAND** is dependent upon the feedback divider ratio configured (29h) **VOUT\_SCALE\_LOOP** as follows:

表 6-1. (29h) **VOUT\_SCALE\_LOOP** and (21h) **VOUT\_COMMAND** Recommended Range

(29h) <b>VOUT_SCALE_LOOP</b>	Recommended <b>V<sub>OUT</sub></b> Range (V)
1	0.5 to 0.75
0.5	0.5 to 1.5
0.25	1 to 3
0.125	2 to 6



Setting (21h) *VOUT\_COMMAND* lower than the recommended range can negatively affect  $V_{OUT}$  regulation accuracy while setting (21h) *VOUT\_COMMAND* above the recommended range can limit the actual output voltage achieved.

**备注**

If the regulation output voltage is limited by the recommended range of the current (29h) *VOUT\_SCALE\_LOOP* value,  $V_{OUT}$  can be below the intended (43h) *VOUT\_UV\_WARN\_LIMIT* or (44h) *VOUT\_UV\_FAULT\_LIMIT* without triggering their respective warning or faults due to the limited range of the reference voltage.

### 6.3.7 Set Output Voltage and Adaptive Voltage Scaling (AVS)

The initial output voltage can be set by the *VSEL* pin at AVIN power up. As part of power-on reset (POR), the *VSEL* pin senses both the resistance from the *VSEL* pin to AGND and the divider ratio of the *VSEL* pin between B1V5 and AGND. These values program (29h) *VOUT\_SCALE\_LOOP*, (21h) *VOUT\_COMMAND*, (2Bh) *VOUT\_MIN*, and (24h) *VOUT\_MAX* and select the appropriate settings for the internal feedback divider and precision adjustable reference voltage. Once the TPSM8D6C24 completes its POR and enables PMBus communication, these initial values can be changed through PMBus communication.

- (20h) *VOUT\_MODE*
- (21h) *VOUT\_COMMAND*
- (29h) *VOUT\_SCALE\_LOOP*
- (22h) *VOUT\_TRIM*
- (25h) *VOUT\_MARGIN\_HIGH*
- (26h) *VOUT\_MARGIN\_LOW*
- (01h) *OPERATION*
- (02h) *ON\_OFF\_CONFIG*

The output voltage can be programmed through PMBus and its value is related to the following registers:

- (24h) *VOUT\_MAX*
- (2Bh) *VOUT\_MIN*
- (40h) *VOUT\_OV\_FAULT\_LIMIT*
- (42h) *VOUT\_OV\_WARN\_LIMIT*
- (43h) *VOUT\_UV\_WARN\_LIMIT*
- (44h) *VOUT\_UV\_FAULT\_LIMIT*

The TPSM8D6C24 defaults to the relative format for the following, but can be changed to use absolute format through the PMBus command (20h) *VOUT\_MODE*:

- (25h) *VOUT\_MARGIN\_HIGH*
- (26h) *VOUT\_MARGIN\_LOW*
- (40h) *VOUT\_OV\_FAULT\_LIMIT*
- (42h) *VOUT\_OV\_WARN\_LIMIT*
- (43h) *VOUT\_UV\_WARN\_LIMIT*
- (44h) *VOUT\_UV\_FAULT\_LIMIT*

Refer to the detailed description of (20h) *VOUT\_MODE* for details.

#### 6.3.7.1 Reset Output Voltage

The (21h) *VOUT\_COMMAND* value and the corresponding output voltage can be reset to the last selected power-on reset value set by *VSEL* or EEPROM as selected in the (EEh) *MFR\_SPECIFIC\_30 (PIN\_DETECT\_OVERRIDE)* command when the PGD/RST\_B pin function is set to RESET# in the (EDh) *MFR\_SPECIFIC\_29 (MISC\_OPTIONS)* PMBus command. To reset (21h) *VOUT\_COMMAND* to its last power-on reset value, when the RESET# optional function is enabled, assert the PGD/RST\_B pin low externally. While

RESET# is asserted low, (21h) *VOUT\_COMMAND* values received through PMBus are ACKed but no change in (21h) *VOUT\_COMMAND* is made. When RESET# is selected in (EDh) *MFR\_SPECIFIC\_29 (MISC\_OPTIONS)*, an internal pullup on the PGD/RST\_B pin can be selected by the PULLUP# bit in the same PMBus command to eliminate the need for an external pullup with the RESET# function.



图 6-7. TPSM8D6C24 Output Voltage Reset

### 6.3.7.2 Soft Start

To control the inrush current needed to charge the output capacitor bank during start-up, the TPSM8D6C24 implements a soft-start time programmed by the (61h) *TON\_RISE* command. When the device is enabled, the reference voltage ramps from 0 V to the final level defined by the following at a slew rate defined by the (61h) *TON\_RISE* command:

- (21h) *VOUT\_COMMAND*
- (29h) *VOUT\_SCALE\_LOOP*
- (22h) *VOUT\_TRIM*
- (25h) *VOUT\_MARGIN\_HIGH*
- (26h) *VOUT\_MARGIN\_LOW*
- (01h) *OPERATION*

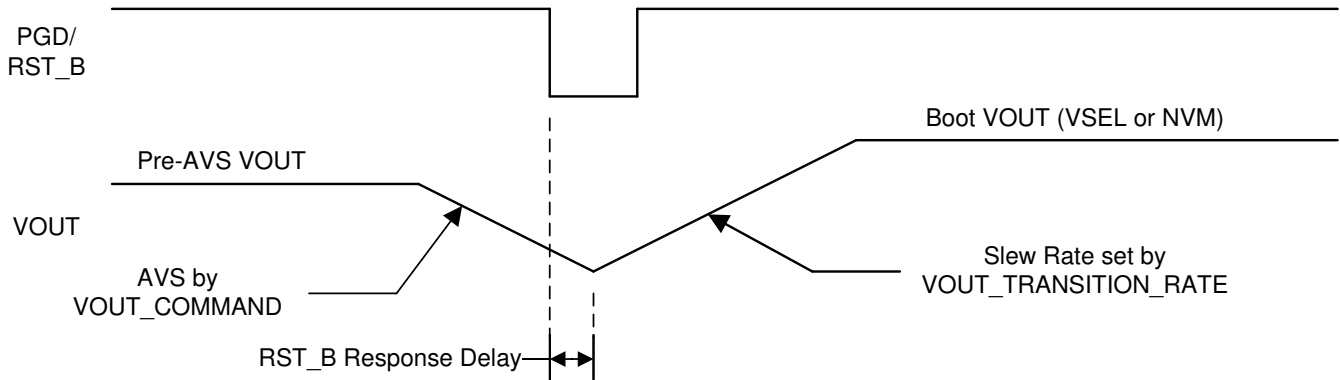
The TPSM8D6C24 devices support several soft-start times from 0 ms to 31.75 ms in 250- $\mu$ s steps (7 bits) selected by the (61h) *TON\_RISE* command. The  $t_{ON\_RISE}$  time is selectable by pinstrapping through the *MSEL2* pin (eight options), PMBus programming, or both.

During soft start, when the PWM pulse width is shorter than the minimum controllable on time, pulse skipping can be seen and the output can show larger ripple voltage than normal operation.

### 6.3.8 Prebiased Output Start-Up

The TPSM8D6C24 limits current from being discharged from a prebiased output voltage during start-up by preventing the low-side FET from forcing the SW node low until after the first PWM pulse turns on the high-side FET. Once VOSNS voltage exceeds the increasing reference voltage and high-side SW pulses start, the TPSM8D6C24 limits the synchronous rectification during each SW period with a narrow on time. The maximum low-side MOSFET on time slowly increases on a cycle-by-cycle basis until 128 switching periods have elapsed and the synchronous rectifier runs fully complementary to the high-side MOSFET. This limits the sinking of current from a prebiased output, and makes sure the output voltage start-up and ramp-to regulation sequences are monotonically increasing.

In the event of a prebiased output voltage greater than (40h) *VOUT\_OV\_FAULT\_LIMIT*, the TPSM8D6C24 responds as soon as it completes POR and VDD5 is greater than its own 3.9-V UVLO, even if conversion is disabled by EN/UVLO or the PMBus (01h) *OPERATION* command.

### 6.3.9 Soft Stop and (65h) TOFF\_FALL Command

When enabled by (02h) *ON\_OFF\_CONFIG* or (01h) *OPERATION*, the TPSM8D6C24 implements the (65h) *TOFF\_FALL* command to force a controlled decrease of the output voltage from regulation to 0. There can be negative inductor current forced during the (65h) *TOFF\_FALL* time to discharge the output voltage. The setting of (65h) *TOFF\_FALL* of 0 ms means the unit to bring its output voltage down to 0 as quickly as possible, which results in an effective (65h) *TOFF\_FALL* time of 0.5 ms. When disabled in the (02h) *ON\_OFF\_CONFIG* for the turn-off controlled by the EN/UVLO pin or bit 6 of (01h) *OPERATION* if the regulator is turned off by (01h) *OPERATION* command, both high-side and low-side FET drivers are turned off immediately and the output voltage slew rate is controlled by the discharge from the external load.

This feature is disabled for EN/UVLO in (02h) *ON\_OFF\_CONFIG* by default.

### 6.3.10 Power Good (PGOOD)

When conversion is enabled and  $t_{ON\_RISE}$  is complete, if the output voltage remains between (43h) *VOUT\_UV\_WARN\_LIMIT* and (42h) *VOUT\_OV\_WARN\_LIMIT*, the PGOOD open-drain output is released and allowed to rise to an externally supplied logic level. Upon any fault condition with a shutdown response, the PGOOD open-drain output is asserted, forcing PGOOD low by default. See 表 6-4 for the possible sources to pull down the PGOOD pin.

The PGOOD signal can be connected to the EN/UVLO pin of another device to provide additional controlled turn-on and turn-off sequencing.

### 6.3.11 Set Switching Frequency

An internal oscillator generates a 275-kHz to 1.1-MHz clock for PWM switching with 16 discrete programmable options. The switching frequency is selectable by pinstrapping through the resistor divider of *MSEL1* (seven options), PMBus programming (nine options), or both, using the (33h) *FREQUENCY\_SWITCH* command listed in 表 6-2.

表 6-2. Oscillator  $f_{SW}$  Options

Programmable $f_{SW}$ Options (kHz)	$f_{SW}$ Pinstrapping Options (kHz)
275	275
325	325
375	—
450	450
550	550
650	650
750	—
900	900
1100	1100

### 6.3.12 Frequency Synchronization

The oscillator can be synchronized to external clock (SYNC IN) or output a clock to synchronize other devices (SYNC out) on the SYNC pin. To support phase shifted clock for both multi-rail interleaving and multi-phase operation, the internal oscillator can be phase-shifted from the SYNC pin by 0, 90, 120, 180, 240, or 270 degrees for 1-, 2-, 3-, or 4-phase operation. The SYNC IN or SYNC OUT function, and phase position of single phase or standalone devices can be selected by pinstrapping through a resistor divider on at the *ADRSEL* pin, or by the resistor from the *MSEL2* pin to AGND for multi-phase loop follower devices.

In single output multi-phase stack configurations, the SYNC phase offset is programmed along with device count and phase position using the *MSEL2* pin. Loop follower devices in multi-phase stacks are always configured as SYNC\_IN while the loop controller device can be configured for auto-detect, SYNC\_IN, or SYNC\_OUT through the resistor divider on the *ADRSEL* pin.

**表 6-3. Pin Programmed Phase Positions through ADRSEL Resistor Divider (Single Phase Standalone)**

RDIV Code	Phase Position (Degree)	SYNC In/Out
Open (No resistor to BP1V5)	0	Auto-detect In/Out
0, 1	0	In
2, 3	90	In
4, 5	120	In
6, 7	180	In
8, 9	240	In
10,11	270	In
12, 13	0	Out
14, 15	180	Out

After initial power up and pin detection, if SYNC IN/OUT is set as auto-detection configuration, the TPSM8D6C24 senses the SYNC pin to determine if there is any external SYNC clock. Switching or a consistent pullup on the SYNC pin sets the device for SYNC\_IN while a consistent pulldown on SYNC sets the device for SYNC\_OUT. The TPSM8D6C24 devices programmed to be loop followers are always programmed to be SYNC IN.

When configured for SYNC\_IN, if SYNC input pulses are missed for two cycles, or the oscillator frequency drops below 50% of the free-running switching frequency, the device determines that SYNC clock is lost. If the TPSM8D6C24 is part of a multi-phase stack, the converter shuts down and remains disabled until a SYNC signal is reestablished to prevent damage due to the loss of synchronization. Single-phase standalone devices continues to operate at approximately 50% of the nominal frequency.

### 6.3.13 Loop Follower Detection

The GOSNS/FLWR pin voltage is detected at power up. When it is pulled high to BP1V5, the device is recognized as a loop follower. When the GOSNS/FLWR pin is connected to the output ground, the TPSM8D6C24 is configured as a loop controller.

### 6.3.14 Current Sensing and Sharing

Both high-side and low-side FET use a SenseFET architecture for current sensing to achieve accurate and temperature-compensated current monitoring. This SenseFET architecture uses the parasitic resistance of the FETs to achieve lossless current sense with no external components.

When multiple (2×, 3×, or 4×) devices operate in a multi-phase application, all devices share the same internal control voltage through the VSHARE pin. The sensed current in each phase is regulated by the VSHARE voltage by an internal transconductance amplifier to achieve loop compensation and current balancing between different phases. The amplifier output voltage is compared with an internal PWM ramp to generate the PWM pulse.

### 6.3.15 Telemetry

The telemetry sub-system in the controller core supports direct measurements of the following:

- Input voltage
- Output voltage
- Output current
- Die temperature

The ADC supports internal rolling window averaging with rolling windows up to 16 previous measurements for accurate measurements of these key system parameters. Each ADC conversion requires less than 500 μs, allowing each telemetry value to be updated within 2 ms.

The current sense telemetry senses the low-side FET current at the start and end of each low-side FET on time and averages the two measurements to monitor the average inductor current over-report current if the inductor

current is non-linear during the low-side FET on time, such as when the inductor is operating above its saturation current.

### 6.3.16 Overcurrent Protection

Both low-side overcurrent (OC) and high-side short circuit protection are implemented.

The low-side overcurrent fault and warning thresholds are programmed through PMBus and sensed across cycle-by-cycle average current through the low-side MOSFET and compared to the set warning or fault threshold while high-side pulses are terminated on a cycle-by-cycle basis, if the peak current through the high-side MOSFET exceeds the 1.5× the programmed low-side threshold.

When either a low-side overcurrent or high-side short circuit threshold is exceeded during a switching cycle, an OCP fault counter is incremented. If no overcurrent condition is detected in a switching cycle, the counter is decremented. If the counter exceeds the delay selected by the (47h) [IOUT\\_OC\\_FAULT\\_RESPONSE](#) PMBus value (default = 3), overcurrent fault condition is declared and the output shuts down. Restart and timing is also defined as part of (47h) [IOUT\\_OC\\_FAULT\\_RESPONSE](#).

The output OC fault thresholds and fault response are set through PMBUS. The OC fault response can be set to shutdown, restart, or ignore.

### 6.3.17 Overvoltage and Undervoltage Protection

The voltage on VOSNS pin is monitored to provide output voltage overvoltage (OV) and undervoltage (UV) protection. When VOSNS voltage is higher than the OV fault threshold, OV fault is declared and the low-side FET is turned on to discharge the output voltage and eliminate the OV condition. The low-side FET remains on until the VOSNS voltage is discharged to 200 mV divide by the internal feedback divider as programmed by (29h) [VOUT\\_SCALE\\_LOOP](#). Once the output voltage is discharged, the output is disabled and the converter times out and restarts according to the (41h) [VOUT\\_OV\\_FAULT\\_RESPONSE](#) PMBus command. When VOSNS voltage is lower than UV fault threshold, UV fault is declared. After an initial delay programmed by the (45h) [VOUT\\_UV\\_FAULT\\_RESPONSE](#) PMBus command, the output is disabled and the converter times out and restarts according to the (45h) [VOUT\\_UV\\_FAULT\\_RESPONSE](#) PMBus command.

The output UV and OV fault thresholds and fault response are set through PMBUS. The UV and OV fault response can be set to shutdown, restart, or continue operating without interruption.

### 6.3.18 Overtemperature Management

There are two schemes of overtemperature protections in the TPSM8D6C24:

- On-chip die temperature sensor for monitoring and overtemperature protection (OTP)
- The bandgap based thermal shutdown (TSD) protection. TSD provides OT fail-safe protection in the event of a failure of the temperature telemetry system, but can be disabled through (50h) [OT\\_FAULT\\_RESPONSE](#) for high temperature testing

The overtemperature protection (OTP) threshold is set through PMBus and compares the (8Dh) [READ\\_TEMPERATURE\\_1](#) telemetry to the (51h) [OT\\_WARN\\_LIMIT](#) and (4Fh) [OT\\_FAULT\\_LIMIT](#). The overtemperature (OT) fault response can be set to shutdown, restart, or continue operating without interruption.

### 6.3.19 Fault Management

For the response on OC fault, OT fault, and thermal shutdown for multi-phase stack, the shutdown response has the highest priority, followed by restart response. Continue operating without interruption response has the lowest priority.

When multiple faults occur in rapid succession, it is possible for the first fault to occur to mask the second fault. If the first fault to be detected is configured to continue operating without interruption, and the second fault is configured to shutdown and restart, the second fault will shutdown but can fail to restart as programmed.

表 6-4. Fault Protection Summary

Fault or Warning	Programming	Fault Response Setting	FET Behavior	Active During $t_{ON\_RISE}$	SMB_ALRT	Maskable	PGOOD Logic
Internal OT fault	(4Fh) OT_FAULT_LIMIT	Shutdown	Both FETs off	Yes	Y	Y	Low
		Restart	Both FETs off, restart				High
		Ignore	FETS still controlled by PWM				
Internal OT warning	(51h) OT_WARN_LIMIT	Shutdown or restart on fault	FETS still controlled by PWM	Yes	Y	Y	High
		Ignore fault					
TSD	Threshold fixed internally	Shutdown	Both FETs off	Yes	Y	Y	Low
		Restart	Both FETs off, restart				High
		Ignore	FETS still controlled by PWM				
Low Side OC fault	(46h) IOUT_OC_FAULT_LIMIT	Shutdown	3 PWM counts, then both FETs off	Yes	Y	Y	Low
		Restart	3 PWM counts, then both FETs off, restart after $[DELAY] \times t_{ON\_RISE}$				High
		Ignore	FETS still controlled by PWM				
Low Side OC warning	(4Ah) IOUT_OC_WARN_LIMIT	Shutdown or restart on fault	FETS still controlled by PWM	Yes	Y	Y	High
		Ignore fault					
Negative OC fault (lower priority than OVF)	N/A	Enable	Turn off LS FET	Yes	Y	Y	Low
		Disable	FETS still controlled by PWM				High
High side OC fault	(46h) IOUT_OC_FAULT_LIMIT	Shutdown	Three cycles of pulse-by-pulse current limiting followed by both FETs off	Yes	Y	Y	Low
		Restart	3 cycles of pulse-by-pulse current limiting followed by both FETs off, restart after $[DELAY] \times t_{ON\_RISE}$				High
		Ignore	FETS still controlled by PWM				
Vout OV fault	(40h) VOUT_OV_FAULT_LIMIT	Shutdown	LS FET latched ON or turned on till $V_{OUT}$ reaches 200 mV/ VOUT_SCALE_LOOP; HS FET OFF	No	Y	Y	Low
		Restart	LS FET latched ON or turned on till $V_{OUT}$ reaches 200 mV/ VOUT_SCALE_LOOP; HS FET OFF, restart after $[DELAY] \times t_{ON\_RISE}$				High
		Ignore	FETS still controlled by PWM				
V <sub>OUT</sub> OVF fix	(40h) VOUT_OV_FAULT_LIMIT	Shutdown	LS FET latched ON or turned on till $V_{OUT}$ reaches 200 mV/ VOUT_SCALE_LOOP; HS FET OFF	Yes	Y	Y	Low
		Restart	LS FET latched ON or turned on till $V_{OUT}$ reaches 200 mV/ VOUT_SCALE_LOOP; HS FET OFF, restart after $[DELAY] \times t_{ON\_RISE}$				High
		Ignore	FETS still controlled by PWM				
Vout OV warning	(42h) VOUT_OV_WARN_LIMIT	Shutdown or restart on fault	FETS still controlled by PWM	No	Y	Y	High
		Ignore fault					
Vout UV fault	(44h) VOUT_UV_FAULT_LIMIT	Shutdown	Both FETs off	No	Y	Y	Low
		Restart	Both FETs off, restart after $[DELAY] \times t_{ON\_RISE}$				High
		Ignore	FETS still controlled by PWM				
Vout UV warning	(43h) VOUT_UV_WARN_LIMIT	Shutdown or restart on fault	FETS still controlled by PWM	No	Y	Y	Low
		Ignore fault					
t <sub>ON MAX</sub> fault	(62h) TON_MAX_FAULT_LIMIT	Shutdown	Both FETs off	Yes	Y	Y	Low
		Restart	Both FETs off, restart after $[DELAY] \times t_{ON\_RISE}$				High
		Ignore	FETS still controlled by PWM				
PVin UVLO	(35h) VIN_ON, (36h) VIN_OFF	Shutdown	Both FETs off	Yes	Y	Y	Low



**表 6-4. Fault Protection Summary (续)**

Fault or Warning	Programming	Fault Response Setting	FET Behavior	Active During $t_{ON\_RISE}$	SMB_ALERT	Maskable	PGOOD Logic
PVIN OV FAULT	(55h) <a href="#">VIN_OV_FAULT_LIMIT</a>	Shutdown	Both FETs off	Yes	Y	Y	Low
		Restart	Both FETs off, restart				High
		Ignore	FETS still controlled by PWM				High
BCX_fault	N/A	N/A	FETS still controlled by PWM	Yes	Y	Y	High
Pin Strap_NonConverge	N/A	VSEL	Both FETs off, pull low VSHARE	No (active before $t_{ON\_RISE}$ )	N	N/A	Low
		MSEL1					
		MSEL2					
		ADRSEL					
SYNC_Fault	N/A	Loop controller or standalone device	FETS still controlled by PWM	Yes	N	N/A	High
		Loop follower device	Both FETs off, pull low VSHARE				Low
SYNC_High/Low	N/A	Loop controller or standalone device	FETS still controlled by PWM	Yes	N	N/A	High
		Loop follower device	Both FETs off, pull low VSHARE				Low

### 6.3.20 Back-Channel Communication

To allow multiple devices with a shared output to communicate through a single PMBus address and single PMBus loop follower, the TPSM8D6C24 uses a back-channel communication implemented through BCX\_CLK and BCX\_DAT pins. During POR, all of the devices connected to VSHARE must also be connected to BCX\_CLK and BCX\_DAT and have appropriate [\(ECh\) MFR\\_SPECIFIC\\_28 \(STACK\\_CONFIG\)](#) settings. Any programming error among the devices of a stack will result in a POR fault and prevent enabling of conversion.

During POR, the loop controller reads the programmed values from the loop followers to make sure all expected loop followers are present and correctly phase-shifted. Then, the loop controller loads critical operating parameters such as the following to the loop follower devices to ensure correct operation of the STACK:

- [\(B1h\) USER\\_DATA\\_01 \(COMPENSATION\\_CONFIG\)](#)
- [\(33h\) FREQUENCY\\_SWITCH](#)
- [\(61h\) TON\\_RISE](#)
- [\(21h\) VOUT\\_COMMAND](#)

During operation, the loop controller device receives and responds to all PMBus communication, and loop follower devices do not need to be connected to the PMBus. If the loop controller receives commands that require updates to the PMBus registers of the loop follower, the loop controller relays these commands to the loop followers. Additionally, the loop controller periodically polls loop follower devices for status and telemetry information to maintain an accurate record of the telemetry and STATUS information for the full stack of devices.

Most PMBus communication must be directed to all phases by leaving the [\(04h\) PHASE](#) PMBus command at its power-on reset default value of FFh. If a specific device must be communicated with, the [\(04h\) PHASE](#) command can be changed to address a specific device within the stack, as set by the order value of the [\(37h\) INTERLEAVE](#) command programmed during POR.

When commands are directed to individual loop followers, write commands are queued by the loop controller to be sent to the loop followers through the BCX if other BCX communication is in progress. Queued write commands are written to the loop followers in the order the loop controller receives them. To avoid unnecessary delays on the PMBus and excessive clock stretching, read transactions targeting individual loop followers are not queued, and are processed as soon as the BCX bus is available. As a result, it is possible for a read command targeting an individual loop follower immediately following a write command can be processed before the preceding write command. To ensure accurate read-back, users must allow a minimum of 4 ms between writing a value to an individual loop follower and reading that same value back from the same loop follower.

### 6.3.21 Switching Node (SW)

The SW pin connects to the switching node of the power conversion stage. The SW pin acts as the return path for the high-side gate driver. When configured as a synchronous buck stage, the voltage swing on SW normally

traverses from below ground to well above the input voltage. Parasitic inductance in the high-side FET and the output capacitance (COSS) of both power FETs form a resonant circuit that can produce high frequency (> 100 MHz) ringing on this node. The voltage peak of this ringing, if not controlled, can be significantly higher than the input voltage. Ensure that the peak ringing amplitude does not exceed the absolute maximum rating limit for the pin.

In many cases, a series resistor and capacitor snubber network connected from the switching node to PGND can be helpful in damping the ringing and decreasing the peak amplitude. Provide provisions for snubber network components in the layout of the printed circuit board. If testing reveals that the ringing amplitude at the SW pin exceeds the limit, then include snubber components.

### 6.3.22 PMBus General Description

Timing and electrical characteristics of the PMBus interface specification can be found in the *PMB Power Management Protocol Specification, Part 1, revision 1.3* available at <http://pmbus.org>. The TPSM8D6C24 device supports the 100-kHz, 400-kHz, and 1-MHz bus timing requirements.

The TPSM8D6C24 uses clock stretching during PMBus communication, but only stretches the clock during specific bits of the transaction.

- The TPSM8D6C24 does not stretch the clock during the address byte of any transaction.
- The TPSM8D6C24 can stretch the clock between bit 0 of the command byte and its ACK response.
- The TPSM8D6C24 stretches the clock after bit 0 of the read address of a read transaction.
- The TPSM8D6C24 stretches the clock between bit 0 of the last byte of data and its ACK response
- The TPSM8D6C24 can stretch the clock between bit 1 and bit zero of every fourth byte of data for blocks with more than four bytes of data.

Communication over the PMBus interface can either support the packet error checking (PEC) scheme or not. If the loop controller supplies clock (CLK) pulses for the PEC byte, PEC is used. If the CLK pulses are not present before a STOP, the PEC is not used. If PEC will always be used, consider enabling Require PEC in [\(EDh\) MFR\\_SPECIFIC\\_29 \(MISC\\_OPTIONS\)](#) to configure the TPSM8D6C24 to reject any write transaction that does not include CLK pulses for a PEC byte.

The device supports a subset of the commands in the *PMBus 1.3 Power Management Protocol Specification*. See [Supported PMBus Commands](#) for more information

The TPSM8D6C24 also supports the SMB\_ALERT response protocol. The SMB\_ALERT response protocol is a mechanism by which the TPSM8D6C24 can alert the bus controller that it has experienced an alert and has important information for the host. The host should process this event and simultaneously access all target devices on the bus that support the protocol through the alert response address. All target devices that are asserting SMB\_ALERT must acknowledge this request with their PMBus address. The host performs a modified receive byte operation to get the address of the target device. At this point, the loop controller can use the PMBus status commands to query the target device that caused the alert. For more information on the SMBus alert response protocol, see the system management bus (SMBus) specification. Persistent faults associated with status registers other than [\(7Eh\) STATUS\\_CML](#) reasserts SMB\_ALERT after responding to the host alert response address.

The TPSM8D6C24 contains nonvolatile memory that is used to store configuration settings and scale factors. The settings programmed into the device are not automatically saved into this nonvolatile memory. The [\(15h\) STORE\\_USER\\_ALL](#) command must be used to commit the current PMBus settings to nonvolatile memory as device defaults. The settings that are capable of being stored in nonvolatile memory are noted in their detailed descriptions.

All pin programmable values can be committed to nonvolatile memory. The POR default selection between pin programmable values and nonvolatile memory can be selected by the manufacturer-specific [\(EEh\) MFR\\_SPECIFIC\\_30 \(PIN\\_DETECT\\_OVERRIDE\)](#) command.



### 6.3.23 PMBus Address

The PMBus specification requires that each device connected to the PMBus has a unique address on the bus. The TPSM8D6C24 PMBus address is determined by the value of the resistor connected between [ADRSEL](#) and AGND and is programmable over the range from 0x10 - 0x2F, providing 32 unique PMBus addresses.

### 6.3.24 PMBus Connections

The TPSM8D6C24 supports the 100-kHz, 400-kHz, and 1-MHz bus speeds. Connection for the PMBus interface must follow the high power DC specifications given in section 3.1.3 in the SMBus specification V2.0 for the 400-kHz bus speed or the low power DC specifications in section 3.1.2. The complete SMBus specification is available from the SMBus web site, [smiforum.org](http://smiforum.org)

The PMBus interface pins PMB\_CLK, PMB\_DATA, and SMB\_ALERT require external pullup resistors to a 1.8-V to 5.5-V termination. Size the pullup resistors to meet the minimize rise-time required for the desired PMBus clock speed but should not source more current than the lowest-rated CLK, DATA, or SMB\_ALERT pin on the bus when the bus voltage is forced to 0.4 V. The TPSM8D6C24 supports a minimum of 20 mA of sink current on PMB\_CLK, PMB\_DATA, and SMB\_ALERT.

## 6.4 Device Functional Modes

### 6.4.1 Programming Mode

The TPSM8D6C24 devices can operate in programming mode when AVIN and VDD5 are powered above their lower UVLO but VDD5 and PVIN are not powered above their UVLO to enable conversion. In programming mode, the TPSM8D6C24 accepts and respond to PMBus commands but does not enable switching or conversion. While PMBus commands can be accepted and processed with VDD5 lower than 3 V, NVM programming through the [\(15h\) STORE\\_USER\\_ALL](#) command must not be used when VDD5 is less than 3 V.

Programming mode allows the TPSM8D6C24 to complete POR and to be configured through PMBus from a 3.3-V supply without PVIN present.

### 6.4.2 Standalone, Loop Controller, and Loop Follower Mode Pin Connections

The TPSM8D6C24 can be programmed as a standalone device (single output, single phase) loop controller device of a single-output, multi-phase stack of devices, or a loop follower device to a loop controller of a multi-phase stack. The details of the recommended pin connects for each configuration is given in [表 6-5](#).

**表 6-5. Standalone, Loop Controller, and Loop Follower Pin Connections**

Pin	Standalone	Loop Controller	Loop Follower
GOSNS	Ground at output regulation point	Ground at output regulation point	BP1V5
VOSNS	V <sub>OUT</sub> at output regulation point	V <sub>OUT</sub> at output regulation point	Float or connect to divider for other voltage to be monitored
EN/UVLO	Enable/Control or resistor divider from PVIN	Enable/Control or resistor divider from PVIN	Connect to EN/UVLO of the loop controller
MSEL1	<a href="#">Programming MSEL1</a>	<a href="#">Programming MSEL1</a>	Short to PGND (thermal pad)
MSEL2	<a href="#">Programming MSEL2</a>	<a href="#">Programming MSEL2</a>	<a href="#">Programming MSEL2 for a Loop Follower Device (GOSNS Tied to BP1V5)</a>
VSEL	<a href="#">Programming VSEL</a>	<a href="#">Programming VSEL</a>	Short to PGND (thermal pad)
ADRSEL	<a href="#">Programming ADRSEL</a>	<a href="#">Programming ADRSEL</a>	Short to PGND (thermal pad)
VSHARE	Float or Bypass to AGND with a capacitor	Connect to VSHARE of the loop follower	Connect to VSHARE of the loop controller
SYNC	Float or external sync	External sync or loop follower SYNC	Connect to SYNC of the loop controller
PMB_CLK	Connect to system PMBus or PGND (thermal pad) if not used	Connect to system PMBus or PGND (thermal pad) if not used	Short to PGND (thermal pad)
PMB_DATA	Connect to system PMBus or PGND (thermal pad) if not used	Connect to system PMBus or PGND (thermal pad) if not used	Short to PGND (thermal pad)

表 6-5. Standalone, Loop Controller, and Loop Follower Pin Connections (续)

Pin	Standalone	Loop Controller	Loop Follower
SMB_ALERT	Connect to system PMBus or PGND (thermal pad) if not used	Connect to system PMBus or PGND (thermal pad) if not used	Short to PGND (thermal pad)
BCX_CLK	Short to PGND (thermal pad)	Connect to loop followers BCX_CLK	Connect to BCX_CLK of the loop controller
BCX_DAT	Short to PGND (thermal pad)	Connect to loop followers BCX_DAT	Connect to BCX_DAT of the loop controller
PGOOD/RST_B	Connect to system PGD or RESET# or PGND (thermal pad) if not used	Connect to system PGD or RESET# or PGND (thermal pad) if not used	Short to PGND (thermal pad)

### 6.4.3 Continuous Conduction Mode

The TPSM8D6C24 devices operate in continuous conduction mode (CCM) at a fixed frequency, regardless of the output current. During soft start, some of the low-side MOSFET on times are limited to prevent excessive current sinking in the event the device is started with a prebiased output. After the first PWM pulse, and with each successive PWM pulse, this limit is increased to allow more low-side FET on time and transition to CCM. Once this transition has completed, the low-side MOSFET and the high-side MOSFET on times are fully complementary.

### 6.4.4 Operation With CNTL Signal (EN/UVLO)

According to the value in the (02h) [ON\\_OFF\\_CONFIG](#) register, the TPSM8D6C24 devices can be commanded to use the EN/UVLO pin to enable or disable regulation, regardless of the state of the (01h) [OPERATION](#) command. The EN/UVLO pin can be configured as either active high or active low (inverted) logic. To use EN/UVLO pin as a programmable UVLO, the polarity set by (02h) [ON\\_OFF\\_CONFIG](#) must be positive logic.

### 6.4.5 Operation with (01h) OPERATION Control

According to the value in the (02h) [ON\\_OFF\\_CONFIG](#) register, the TPSM8D6C24 devices can be commanded to use the (01h) [OPERATION](#) command to enable or disable regulation, regardless of the state of the CNTL signal.

### 6.4.6 Operation with CNTL and (01h) OPERATION Control

According to the value in the (02h) [ON\\_OFF\\_CONFIG](#) command, the TPSM8D6C24 devices can be commanded to require both a CNTRL signal from the EN/UVLO pin, and the (01h) [OPERATION](#) command to enable or disable regulation.

## 6.5 Programming

### 6.5.1 Supported PMBus Commands

The commands listed in 表 6-6 are implemented as described to conform to the PMBus 1.3 specification. 表 6-6 also lists the default for the bit behavior and register values.

表 6-6. Supported PMBus Commands and Default Values

CMD Code (HEX)	Command Name (PMBus 1.3 SPEC)	Default Value
01h	<a href="#">OPERATION</a>	04h
02h	<a href="#">ON_OFF_CONFIG</a>	17h
03h	<a href="#">CLEAR_FAULTS</a>	n/a
04h	<a href="#">PHASE</a>	FFh
10h	<a href="#">WRITE_PROTECT</a>	00h
15h	<a href="#">STORE_USER_ALL</a>	n/a
16h	<a href="#">RESTORE_USER_ALL</a>	n/a
19h	<a href="#">CAPABILITY</a>	D0h
1Bh	<a href="#">SMBALERT_MASK</a>	n/a
20h	<a href="#">VOUT_MODE</a>	97h

**表 6-6. Supported PMBus Commands and Default Values (续)**

CMD Code (HEX)	Command Name (PMBus 1.3 SPEC)	Default Value
21h	VOUT_COMMAND	019Ah
22h	VOUT_TRIM	0000h
24h	VOUT_MAX	0C00h
25h	VOUT_MARGIN_HIGH	021Ah
26h	VOUT_MARGIN_LOW	01E6h
27h	VOUT_TRANSITION_RATE	E010h
29h	VOUT_SCALE_LOOP	C840h
2Bh	VOUT_MIN	0100h
33h	FREQUENCY_SWITCH	01C2h
35h	VIN_ON	F00Bh
36h	VIN_OFF	F00Ah
37h	INTERLEAVE	0020h
38h	IOUT_CAL_GAIN	C880h
39h	IOUT_CAL_OFFSET	E000h
40h	VOUT_OV_FAULT_LIMIT	024Dh
41h	VOUT_OV_FAULT_RESPONSE	BDh
42h	VOUT_OV_WARN_LIMIT	022Eh
43h	VOUT_UV_WARN_LIMIT	01CCh
44h	VOUT_UV_FAULT_LIMIT	01B2h
45h	VOUT_UV_FAULT_RESPONSE	BEh
46h	IOUT_OC_FAULT_LIMIT	F0D0h
47h	IOUT_OC_FAULT_RESPONSE	FFh
4Ah	IOUT_OC_WARN_LIMIT	F0A0h
4Fh	OT_FAULT_LIMIT	0096h
50h	OT_FAULT_RESPONSE	BCh
51h	OT_WARN_LIMIT	007Dh
55h	VIN_OV_FAULT_LIMIT	0015
56h	VIN_OV_FAULT_RESPONSE	3Ch
58h	VIN_UV_WARN_LIMIT	F00Ah
60h	TON_DELAY	F800h
61h	TON_RISE	F00Ch
62h	TON_MAX_FAULT_LIMIT	F800h
63h	TON_MAX_FAULT_RESPONSE	3Bh
64h	TOFF_DELAY	F800h
65h	TOFF_FALL	F002h
78h	STATUS_BYTE	00h
79h	STATUS_WORD	00h
7Ah	STATUS_VOUT	00h
7Bh	STATUS_IOUT	00h
7Ch	STATUS_INPUT	00h
7Dh	STATUS_TEMPERATURE	00h
7Eh	STATUS_CML	00h
7Fh	STATUS_OTHER	00h
80h	STATUS_MFR_SPECIFIC	00h
88h	READ_VIN	n/a

表 6-6. Supported PMBus Commands and Default Values (续)

CMD Code (HEX)	Command Name (PMBus 1.3 SPEC)	Default Value
8Bh	READ_VOUT	n/a
8Ch	READ_IOUT	n/a
8Dh	READ_TEMPERATURE_1	n/a
98h	PMBUS_REVISION	33h
99h	MFR_ID	00 00 00h
9Ah	MFR_MODEL	00 00 00h
9Bh	MFR_REVISION	00 00 00h
9Eh	MFR_SERIAL	00 00 00h
ADh	IC_DEVICE_ID	54 49 54 6D 24 41h
AEh	IC_DEVICE_REV	40 00h
B1h	USER_DATA_01 (COMPENSATION_CONFIG)	22 18 C2 1D 06h
B5h	USER_DATA_05 (POWER_STAGE_CONFIG)	70h
D0h	MFR_SPECIFIC_00 (TELEMETRY_CONFIG)	03 03 03 03 03 00h
DAh	MFR_SPECIFIC_10 (READ_ALL)	n/a
DBh	MFR_SPECIFIC_11 (STATUS_ALL)	n/a
E4h	MFR_SPECIFIC_20 (SYNC_CONFIG)	F0h
ECh	MFR_SPECIFIC_28 (STACK_CONFIG)	0000h
EDh	MFR_SPECIFIC_29 (MISC_OPTIONS)	0000h
EEh	MFR_SPECIFIC_30 (PIN_DETECT_OVERRIDE)	1F2Fh
EFh	MFR_SPECIFIC_31 (Loop Follower_ADDRESS)	24h
F0h	MFR_SPECIFIC_32 (NVM_CHECKSUM)	E9E0h
F1h	MFR_SPECIFIC_33 (SIMULATE_FAULTS)	0000h
FCh	MFR_SPECIFIC_44 (FUSION_ID0)	02C0h
FDh	MFR_SPECIFIC_45 (FUSION_ID1)	54 49 4C 4F 43 4Bh

### 6.5.2 Pin Strapping

The TPSM8D6C24 provides four IC pins that allow the initial PMBus programming value on critical PMBus commands to be selected by the resistors connected to that pin without requiring PMBus communication. Whether a specific PMBus command is initialized to the value selected by the detected resistance or stored NVM memory is determined by the commands bit in the PIN\_DETECT\_OVERRIDE PMBus Command. The four pins and the commands they program for a loop controller or standalone device (GOSNS connected to Ground) are provided in 表 6-7.

Each pin can be programmed in one of four ways:

- Pin shorted to AGND with less than 20  $\Omega$
- Pin floating or tied to BP1V5 with more than 1 M $\Omega$
- Pin bypassed to AGND through a resistor according to R2G code only (16 resistor options)
- Pin bypassed to AGND through a resistor according to R2G code and to BP1V5 according to Divider Code (16 resistor  $\times$  16 resistor divider options)

Due to the flexibility of programming options with up to 274 configurations per pin, it is recommended that designers consider using one of the available design tools, such as [TPS546x24A Compensation and Pin-Strap Resistor Calculator](#) to assist with proper programming resistor selection.

表 6-7. TPSM8D6C24 Pin Programming Summary

Pin	Resistors	PMBus Registers
MSEL1	Resistor to AGND	COMPENSATION_CONFIG
	Resistor Divider	COMPENSATION_CONFIG, FREQUENCY_SWITCH

表 6-7. TPSM8D6C24 Pin Programming Summary (续)

Pin	Resistors	PMBus Registers
MSEL2	Resistor to AGND	IOUT_OC_WARN_LIMIT, IOUT_OC_FAULT_LIMIT, STACK_CONFIG
	Resistor Divider	TON_RISE
VSEL	Both	VOUT_COMMAND, VOUT_SCALE_LOOP, VOUT_MAX, VOUT_MIN
ADRSEL	Resistor to AGND	loop_follower_ADDRESS
	Resistor Divider	loop_follower_ADDRESS, SYNC_CONFIG, INTERLEAVE

备注

Resistor divider values of "none" can be implemented with no resistor to BP1V5 or use a 1-M $\Omega$  resistor to BP1V5 for improved reliability and noise immunity.

loop follower devices with GOSNS tied to BP1V5 only use the resistor from [MSEL2](#) to AGND to program the following:

- [\(4Ah\) IOUT\\_OC\\_WARN\\_LIMIT](#)
- [\(46h\) IOUT\\_OC\\_FAULT\\_LIMIT](#)
- [\(Ech\) MFR\\_SPECIFIC\\_28 \(STACK\\_CONFIG\)](#)
- [\(37h\) INTERLEAVE](#)

The loop follower receives all other pin programmed values from the loop controller over BCX as part of the power-on reset function.

备注

The high precision Pin-Detection programming which provides 8-bit resolution for each pin in the TPSM8D6C24 can be sensitive to PCB contamination from flux, moisture, and debris. As such, users should consider committing Pin Programmed values to User Non-Volatile memory and disable future use of Pin Strapped values as part of the product flow. The programming sequence to commit Pin Programmed PMBus register values to NVM and disable future use of Pin Strapped programming is:

- Select [MSEL1](#), [MSEL2](#), [VSEL](#), and [ADRSEL](#) programming resistors to program the desired PMBus register values.
- Power AVIN and VDD5 above their UVLOs to initiate pin detection and enable PMBus communication.
- Update any PMBus register values not programmed to their final value by pin detection.
- Write the value 0000h using the Write Word protocol to [\(EEh\) MFR\\_SPECIFIC\\_30 \(PIN\\_DETECT\\_OVERRIDE\)](#).
- Send the command code 15h using the Send Byte protocol to initialize a [\(15h\) STORE\\_USER\\_ALL](#) function.
- Allow a minimum 100 ms for the device to complete a burn of NVM User Store. Loss of AVIN or VDD5 power during this 100 ms can compromise the integrity of the NVM. Failure to complete the NVM burn can result in a corruption of NVM and a POR fault on subsequent power on resets.

### 6.5.2.1 Programming MSEL1

The MSEL1 pin programs [\(B1h\) USER\\_DATA\\_01 \(COMPENSATION\\_CONFIG\)](#) and [\(33h\) FREQUENCY\\_SWITCH](#). The resistor divider ratio for MSEL1 selects the nominal switching frequency using 表 6-8:

表 6-8. MSEL1 Divider Code for Programming

Resistor Divider Code	COMPENSATION_CONFIG (CONFIG #)	FREQUENCY_SWITCH Value (kHz)
None (no resistor to BP1V5)	7-25 (select values)	550
0	0-15	275
1	16-31	
2	0-15	325
3	16-31	
4	0-15	450
5	16-31	
6	0-15	550
7	16-31	
8	0-15	650
9	16-31	
10	0-15	900
11	16-31	
12	0-15	1100
13	16-31	
14	0-15	1500
15	16-31	

The resistor to ground for MSEL1 selects the (B1h) *USER\_DATA\_01 (COMPENSATION\_CONFIG)* values to program the following voltage loop and current loop gains. For options other than the EEPROM code (MSEL1 shorted to AGND or MSEL1 to AGND resistor code 0), the current and voltage loop zero and pole frequencies are scaled with the programmed switching frequency. The current loop pole frequency is scale located at approximately the switching frequency, while the current loop zero is located at approximately 1 / 20 the switching frequency. the voltage loop pole is located at approximately 1 / 2 the switching frequency and the voltage loop zero is located at approximately 1 / 100 the switching frequency.

表 6-9. MSEL1 Resistor to AGND Code with no Divider Programming

Resistor Code	Compensation (No Divider)			Compensation (Even Divider)			Compensation (Odd Divider)		
	Config #	I Loop Gain	V Loop Gain	Config #	I Loop Gain	V Loop Gain	Config #	I Loop Gain	V Loop Gain
Short	3	2	2	N/A	N/A	N/A	N/A	N/A	N/A
Float	EEPROM	EEPROM	EEPROM	N/A	N/A	N/A	N/A	N/A	N/A
0	7	3	1	0	EEPROM	EEPROM	16	5	0.5
1	8	3	2	1	2	0.5	17	5	1
2	9	3	4	2	2	1	18	5	2
3	10	3	8	3	2	2	19	5	4
4	12	4	1	4	2	4	20	5	8
5	13	4	2	5	2	8	21	6	0.5
6	14	4	4	6	3	0.5	22	6	1
7	15	4	8	7	3	1	23	6	2
8	17	5	1	8	3	2	24	6	4
9	18	5	2	9	3	4	25	6	8
10	19	5	4	10	3	8	26	7	0.5
11	20	5	8	11	4	0.5	27	7	1

**表 6-9. MSEL1 Resistor to AGND Code with no Divider Programming (续)**

Resistor Code	Compensation (No Divider)			Compensation (Even Divider)			Compensation (Odd Divider)		
	Config #	I Loop Gain	V Loop Gain	Config #	I Loop Gain	V Loop Gain	Config #	I Loop Gain	V Loop Gain
12	22	6	1	12	4	1	28	7	2
13	23	6	2	13	4	2	20	7	4
14	24	6	4	14	4	4	30	7	8
15	25	6	8	15	4	8	21	10	2

With both the resistor to ground code and the resistor divider code, use the look-up table to select the appropriate resistors.

### 6.5.2.2 Programming MSEL2

The resistor divider on MSEL2 pin programs the (61h) *TON\_RISE* value to select the soft-start time used by the TPSM8D6C24.

**表 6-10. MSEL2 Divider Code for Programming**

Resistor Divider Code	<i>TON_RISE</i> Value (ms)
None (No resistor to BP1V5)	3
Short to AGND	
Float	
0	0.5
1	1
2	3
3	5
4	7
5	10
6	20
7	31.75

The resistor to ground for MSEL2 selects the (4Ah) *IOUT\_OC\_WARN\_LIMIT*, (46h) *IOUT\_OC\_FAULT\_LIMIT*, and (ECh) *MFR\_SPECIFIC\_28 (STACK\_CONFIG)* values using 表 6-11.

**表 6-11. MSEL2 Resistor to AGND Code for IOUT\_OC\_WARN/FAULT\_LIMIT and STACK Programming**

Resistor to AGND Code	<i>STACK_CONFIG</i> (Number OF Loop Followers / # of Phases)	<i>OC_WARN (A)/OC_FAULT (A)</i>
Short	0000h (0 loop followers, standalone)	40/52
Float	0001h (1 loop follower, 2-phase)	40/52
0	0000h (0 loop followers, standalone)	40/52
1	0001h (1 loop follower, 2-phase)	
2	0002h (2 loop followers, 3-phase)	
3	0003h (3 loop followers, 4-phase)	
4	0000h (0 loop followers, standalone)	30/39
5	0001h (1 loop follower, 2-phase)	
6	0002h (2 loop followers, 3-phase)	
7	0003h (3 loop followers, 4-phase)	
8	0000h (0 loop followers, standalone)	20/26
9	0001h (1 loop follower, 2-phase)	
10	0002h (2 loop followers, 3-phase)	
11	0003h (3 loop followers, 4-phase)	
12	0000h (0 loop followers, standalone)	10/14
13	0001h (1 loop follower, 2-phase)	
14	0002h (2 loop followers, 3-phase)	
15	0003h (3 loop followers, 4-phase)	



### 6.5.2.3 Programming VSEL

The resistor divider ratio for VSEL programs the (21h) *VOUT\_COMMAND* range, (29h) *VOUT\_SCALE\_LOOP* divider, (2Bh) *VOUT\_MIN*, and (24h) *VOUT\_MAX* levels according to the following tables.

Select the resistor divider code that contains the desired nominal boot voltage within the range of  $V_{OUT}$  between minimum  $V_{OUT}$  and maximum  $V_{OUT}$ . For voltages from 0.5 V to 1.25 V, a single resistor to ground or a resistor divider can be used.

**表 6-12. VSEL Resistor Divider Code for Programming**

Nominal Boot Voltage Range			Resistor Divider Code
Minimum $V_{OUT}$	Maximum $V_{OUT}$	Resolution	
EEPROM (0.8 V)	EEPROM (0.8 V)	N/A	Float
0.5	1.25	0.050	Open (bot resistor only)
0.6	0.75	0.010	0
0.75	0.9	0.010	1
0.9	1.05	0.010	2
1.05	1.2	0.010	3
1.2	1.5	0.020	4
1.5	1.8	0.020	5
1.8	2.1	0.020	6
2.1	2.4	0.020	7
2.4	3.0	0.040	8
3.0	3.6	0.040	9
3.6	4.2	0.040	10
4.2	4.8	0.040	11
3.6	4.2	0.040	12
4.2	4.8	0.040	13
4.8	5.4	0.040	14
5.4	6.0	0.040	15

With the resistor divider code selected for the range of  $V_{OUT}$ , select the bottom resistor code with the (21h) *VOUT\_COMMAND* offset and (21h) *VOUT\_COMMAND* step from *Programming VSEL*.

**表 6-13. VSEL Resistor to AGND Code for Programming**

Resistor Divider Code	<i>VOUT_SCALE_LOOP</i>	<i>VOUT_MIN</i>	<i>VOUT_MAX</i>	<i>VOUT_COMMAND</i> Offset (V)	<i>VOUT_COMMAND</i> Step (V)
Short to AGND	0.5	EEPROM (0.5)	EEPROM (1.5)	EEPROM (0.80)	N/A
Float	0.5	0.5	1.5	1.0	N/A
None	0.5	0.5	1.5	0.50	0.050
0	0.5	0.5	1.5	0.6	0.010
1	0.5	0.5	1.5	0.75	0.010
2	0.5	0.5	1.5	0.9	0.010
3	0.5	0.5	1.5	1.05	0.010
4	0.25	1	3	1.2	0.020
5	0.25	1	3	1.5	0.020
6	0.25	1	3	1.8	0.020
7	0.25	1	3	2.1	0.020

表 6-13. VSEL Resistor to AGND Code for Programming (续)

Resistor Divider Code	VOUT_SCALE_LOOP	VOUT_MIN	VOUT_MAX	VOUT_COMMAND Offset (V)	VOUT_COMMAND Step (V)
8	0.125	2	6	2.4	0.040
9	0.125	2	6	3.0	0.040
10	0.125	2	6	3.6	0.040
11	0.125	2	6	4.2	0.040
12	0.125	2	6	3.6	0.040
13	0.125	2	6	4.2	0.040
14	0.125	2	6	4.8	0.040
15	0.125	2	6	5.4	0.040

To calculate the resistor to AGND code, subtract the (21h) *VOUT\_COMMAND* offset from the target output voltage and divide by the (21h) *VOUT\_COMMAND* step.

$$\text{Code} = \frac{V_{\text{OUT}} - \text{VOUT\_COMMAND(Offset)}}{\text{VOUT\_COMMAND(Step)}} \quad (8)$$

#### 6.5.2.4 Programming ADRSEL

The resistor divider for the ADRSEL pin selects the range of PMBus addresses and SYNC direction for the TPSM8D6C24. For standalone devices with only one device supporting a single output voltage, the ADRSEL divider also selects the phase shift between SYNC and the switch node.

表 6-14. ADRSEL Resistor Divider Code for and SYNC\_IN Programming

Resistor Divider Code	DEVICE_ADDRESS	Sync In/Sync Out	STACK_CONFIG = 0x0000 (Standalone Only)	
—	Range	—	PHASE SHIFT	INTERLEAVE
Short to AGND	0x7F (127d)	Auto Detect	0	0x0020
Float	EEPROM (0x24h / 36d)	Auto Detect	0	0x0020
None	16d-31d	Auto detect	0	0x0020
0	16d-31d	Sync in	0	0x0040
1	32d-47d	Sync in	0	0x0040
2	16d-31d	Sync in	90	0x0041
3	32d-47d	Sync in	90	0x0041
4	16d-31d	Sync in	120	0x0031
5	32d-47d	Sync in	120	0x0031
6	16d-31d	Sync in	180	0x0042
7	32d-47d	Sync in	180	0x0042
8	16d-31d	Sync in	240	0x0032
9	32d-47d	Sync in	240	0x0032
10	16d-31d	Sync in	270	0x0043
11	32d-47d	Sync in	270	0x0043
12	16d-31d	Sync out	0	0x0020
13	32d-47d	Sync out	0	0x0020
14	16d-31d	Sync out	180	0x0042
15	32d-47d	Sync out	180	0x0042

The resistor to AGND for ADRSEL programs the device PMBus target device address according to 表 6-15:

表 6-15. ADRSEL Resistor to AGND Code for Programming

Resistor to AGND Code	Target Device Address (16-31 Range)	Target Device Address (32-47 Range)
0	0x10h (16d)	0x20h (32d)
1	0x11h (17d)	0x21h (33d)
2	0x12h (18d)	0x22h (34d)
3	0x13h (19d)	0x23h (35d)
4	0x14h (20d)	0x24h (36d)
5	0x15h (21d)	0x25h (37d)
6	0x16h (22d)	0x26h (38d)
7	0x17h (23d)	0x27h (39d)
8	0x18h (24d)	0x48h (72d)
9	0x19h (25d)	0x29h (41d)
10	0x1Ah (26d)	0x2Ah (42d)
11	0x1Bh (27d)	0x2Bh (43d)
12	0x1Ch (28d)	0x2Ch (44d)
13	0x1Dh (29d)	0x2Dh (45d)
14	0x1Eh (30d)	0x2Eh (46d)
15	0x1Fh (31d)	0x2Fh (47d)

备注

When a TPSM8D6C24 device is configured as the loop controller of a multi-phase stack, it will always occupy the zero-degree position in (37h) *INTERLEAVE*, but the ADRSEL resistor divider can still be used to select Auto Detect, Forced SYNC\_IN, and Forced SYNC\_OUT. When the loop controller of a multi-phase stack is configured for SYNC\_IN, all devices of the stack remain disabled until a valid external SYNC signal is provided.

6.5.2.5 Programming MSEL2 for a Loop Follower Device (GOSNS Tied to BP1V5)

Configuring a TPSM8D6C24 device as a loop follower disables all pinstraps except MSEL2, which programs (37h) *INTERLEAVE* for stacking and (ECh) *MFR\_SPECIFIC\_28 (STACK\_CONFIG)*, (4Ah) *IOUT\_OC\_WARN\_LIMIT*, and (46h) *IOUT\_OC\_FAULT\_LIMIT* with a single resistor to AGND. Note that the loop controller is always device 0.

表 6-16. Loop Follower MSEL2 Resistor to AGND Code for and Programming

Resistor to AGND Code	Device Number, Number of Phases	IOUT_OC_WARN_LIMIT (A)/ IOUT_OC_FAULT_LIMIT (A)
Short	Device 1, 2-phase	40/52
Float	Device 1, 2-phase	30/39
6	Device 1, 2-phase	40/52
7	Device 1, 2-phase	30/39
4	Device 1, 3-phase	40/52
5	Device 1, 3-phase	30/39
8	Device 2, 3-phase	40/52
9	Device 2, 3-phase	30/39
2	Device 1, 4-phase	40/52
3	Device 1, 4-phase	30/39
14	Device 2, 4-phase	40/52
15	Device 2, 4-phase	30/39

**表 6-16. Loop Follower MSEL2 Resistor to AGND Code for and Programming**  
(续)

Resistor to AGND Code	Device Number, Number of Phases	IOUT_OC_WARN_LIMIT (A)/ IOUT_OC_FAULT_LIMIT (A)
10	Device 3, 4-phase	40/52
11	Device 3, 4-phase	30/39

**备注**

During the power-on sequence, device 0 (stack loop controller) reads back phase information from all connected loop followers, if any loop follower phase response does not match the (ECh) *MFR\_SPECIFIC\_28 (STACK\_CONFIG)* results of the loop controller, the converter sets the POR fault bit in (80h) *STATUS\_MFR\_SPECIFIC* but does not allow conversion. Once all connected devices respond to device 0, device 0 passes remaining pin-strap information to the loop followers to ensure matched programming during operation. Adding an additional phase requires adjusting the MSEL2 resistors on the loop controller device and the MSEL2 resistor to ground on all other loop follower devices.

### 6.5.2.6 Pin-Strapping Resistor Configuration

表 6-17 和 表 6-18 provide the bottom resistor (pin to AGND) values in ohms, and the top resistor (pin to BP1V5) values in  $\Omega$ s. Select the column with the desired R2G code in the top row and the row with the desired resistor divider code in the left most column. The Pin-to-AGND resistor value is the resistor value in the highlighted row in the first column under the desired R2G code. The Pin-to-BP1V5 resistor value, if used, is the resistor value in the row starting with the desired divider code in the left most column under the desired R2G code and resistor. To ensure accurate pin detection over operating temperature and product life-time, 1% tolerance or better resistors should be used.

**表 6-17. Pin-Strapping Resistor ( $\Omega$ ) Table for R2G Codes 0-7**

R2G code	0	1	2	3	4	5	6	7
Rbot →	4640	5620	6810	8250	10000	12100	14700	17800
Divider Code (↓)	Resistor to BP1V5 Value ( $\Omega$ )							
0	21500	26100	31600	38300	46400	56200	68100	82500
1	15400	18700	22600	27400	33200	40200	48700	59000
2	11500	14000	16900	20500	24900	30100	36500	44200
3	9090	11000	13300	16200	19600	23700	28700	34800
4	7150	8660	10500	12700	15400	18700	22600	27400
5	5620	6810	8250	10000	12100	14700	17800	21500
6	4640	5620	6810	8250	10000	12100	14700	17800
7	3830	4640	5620	6810	8250	10000	12100	14700
8	3160	3830	4640	5620	6810	8250	10000	12100
9	2610	3160	3830	4640	5620	6810	8250	10000
10	2050	2490	3010	3650	4420	5360	6490	7870
11	1620	1960	2370	2870	3480	4220	5110	6190
12	1270	1540	1870	2260	2740	3320	4020	4870
13	953	1150	1400	1690	2050	2490	3010	3650
14	715	866	1050	1270	1540	1870	2260	2740
15	511	619	750	909	1100	1330	1620	1960

**表 6-18. Pin-Strapping Resistor ( $\Omega$ ) Table for R2G Codes 8-15**

R2G code	8	9	10	11	12	13	14	15
Rbot →	21500	26100	31600	38300	46400	56200	68100	82500
Divider Code (↓)	Resistor to BP1V5 Value ( $\Omega$ )							
0	100000	121000	147000	178000	215000	261000	316000	402000
1	71500	86600	105000	127000	154000	187000	226000	274000
2	53600	64900	78700	95300	115000	140000	169000	205000
3	42200	51100	61900	75000	90900	110000	133000	162000
4	33200	40200	48700	59000	71500	86600	105000	127000
5	26100	31600	38300	46400	56200	68100	82500	100000
6	21500	26100	31600	38300	46400	56200	68100	82500
7	17800	21500	26100	31600	38300	46400	56200	68100
8	14700	17800	21500	26100	31600	38300	46400	56200
9	12100	14700	17800	21500	26100	31600	38300	46400
10	9530	11500	14000	16900	20500	24900	30100	26500
11	7500	9090	11000	13300	16200	19600	23700	28700
12	5900	7150	8660	10500	12700	15400	18700	22600
13	4420	5360	6490	7870	9530	11500	14000	16900
14	3320	4020	4870	5900	7150	8660	10500	12700
15	2370	2870	3480	4220	5110	6190	7500	9090

## 6.6 Register Maps

### 6.6.1 Conventions for Documenting Block Commands

According to the SMBus specification, block commands are transmitted across the PMBus interface in ascending order. The description below shows the convention this document follows for documenting block commands.

This document follows the convention for byte ordering of block commands:

When block values are listed as register map tables, they are listed in byte order from top to bottom starting with Byte N and ending with Byte 0.

- Byte 0 (first byte sent) corresponds to bits 7:0.
- Byte 1 (second byte sent) corresponds to bits 15:8.
- Byte 2 (third byte sent) corresponds to bits 23:16.
- ... and so on

When block values are listed as text in hexadecimal, they are listed in byte order, from left to right, starting with Byte 0 and ending with Byte N with a space between each byte of the value. In block 54 49 54 6D 24 41h, the byte order is:

- Byte 0, bits 7:0, = 54h
- Byte 1, bits 15:8, = 49h
- Byte 2, bits 23:16, = 6Dh
- Byte 3, bits 31:24, = 24h
- Byte 4, bits 39:32, = 41h

**图 6-8. Block Command Byte Ordering**

47	46	45	44	43	42	41	40
RW	RW	RW	RW	RW	RW	RW	RW
Byte N							
39	38	37	36	35	34	33	32
RW	RW	RW	RW	RW	RW	RW	RW
Byte ...							
31	30	29	28	27	26	25	24
RW	RW	RW	RW	RW	RW	RW	RW
Byte 3							
23	22	21	20	19	18	17	16
RW	RW	RW	RW	RW	RW	RW	RW
Byte 2							
15	14	13	12	11	10	9	8
RW	RW	RW	RW	RW	RW	RW	RW
Byte 1							
7	6	5	4	3	2	1	0
RW	RW	RW	RW	RW	RW	RW	RW
Byte 0							

LEGEND: R/W = Read/Write; R = Read only

## 6.6.2 (01h) OPERATION

CMD Address	01h
Write Transaction:	Write Byte
Read Transaction:	Read Byte
Format:	Unsigned Binary (1 byte)
Phased:	No
NVM Backup:	No
Updates:	On-the-fly

The (01h) OPERATION command is used to enable or disable power conversion, in conjunction input from the enable pins, according to the configuration of the (02h) ON\_OFF\_CONFIG command. This command is also used to set the output voltage to the upper or lower MARGIN levels, and select soft-stop.

图 6-9. (01h) OPERATION Register Map

7	6	5	4	3	2	1	0	
RW	RW	RW	RW	RW	RW	RW	R	
ON_OFF	SOFT_OFF	MARGIN				TRANSITION		0

LEGEND: R/W = Read/Write; R = Read only

表 6-19. Register Field Descriptions

Bit	Field	Access	Reset	Description
7	ON_OFF	RW	0b	Enable or disable power conversion when the (02h) ON_OFF_CONFIG command is configured to require input from the CMD bit for output control. There can be several other requirements that must be satisfied before the power conversion can begin (for example, input voltages above UVLO thresholds, enable pins high if required by (02h) ON_OFF_CONFIG, and so forth). 0b: Disable power conversion. 1b: Enable power conversion and enable ignore faults on MARGIN.
6	SOFT_OFF	RW	0b	This bit controls the turn-off profile when (02h) ON_OFF_CONFIG is configured to require input from the CMD bit for output voltage control and OPERATION bit 7 transitions from 1b to 0b is ignored when bit 7 is 1b. 0b: Immediate off. Power conversion stops immediately and the power stage is forced to a high-Z state. 1b: Soft off. Power conversion continues for the $t_{OFF\_DELAY}$ time, then the output voltage is ramped down to 0 V at a slew rate according to $t_{OFF\_FALL}$ . Once the output voltage reaches 0 V, power conversions stops.
5:2	MARGIN	RW	0000b	Sets the margin state. 0000b, 0001b, 0010b: Margin OFF. Output voltage target is (21h) VOUT_COMMAND. OV and UV faults behave normally per their respective fault response settings 0. 0101b: Margin low (ignore fault if bit 7 is 1b). Output voltage target is VOUT_MARGIN_LOW. OV and UV faults are ignored and do not trigger shutdown or STATUS updates. 0110b: Margin low (act on fault). Output voltage target is (26h) VOUT_MARGIN_LOW. OV/UV faults trigger per their respective fault response settings. 1001b: Margin high (ignore fault). Output voltage target is VOUT_MARGIN_HIGH. OV and UV triggers are ignored and do not trigger shutdown or STATUS update. 1010b: Margin high (act on fault). Output voltage target is (25h) VOUT_MARGIN_HIGH. OV/UV trigger per their respective fault response settings. Other: Invalid/unsupported data
1	TRANSITION	R	0b	Not used and always set to 0.
0	Reserved	R	0b	Not used and always set to 0.

Attempts to write (01h) OPERATION to any value other than those listed above are considered invalid or unsupported data and cause the TPSM8D6C24 to respond by flagging the appropriate status bits, and notifying the host according to the PMBus 1.3.1 Part II specification, section 10.9.3.



### 6.6.3 (02h) ON\_OFF\_CONFIG

CMD Address	02h
Write Transaction:	Write Byte
Read Transaction:	Read Byte
Format:	Unsigned Binary (1 byte)
Phased:	No
NVM Backup:	EEPROM
Updates:	On-the-fly

The (02h) ON\_OFF\_CONFIG command configures the combination of enable pin input and serial bus commands needed to enable or disable power conversion, including how the unit responds when power is applied to PVIN.

图 6-10. (02h) ON\_OFF\_CONFIG Register Map

7	6	5	4	3	2	1	0
R	R	R	RW	RW	RW	RW	RW
0	0	0	PU	CMD	CP	POLARITY	DELAY

LEGEND: R/W = Read/Write; R = Read only

表 6-20. Register Field Descriptions

Bit	Field	Access	Reset	Description
7:5	Reserved	R	000b	Not used and always set to 0.
4	PU	RW	NVM	0b: Unit starts power conversion any time the input power is present, regardless of the state of the CONTROL pin. 1b: Act on CONTROL. Use the (01h) OPERATION command to start or stop power conversion, or both.
3	CMD	RW	NVM	0b: Ignore the (01h) OPERATION command to start or stop power conversion. 1b: Act on the (01h) OPERATION command (and the CONTROL pin if configured by CP) to start or stop power conversion.
2	CP	RW	NVM	0b: Ignore the CONTROL pin to start or stop power conversion. The UVLO function of the EN/UVLO pin is not active when CONTROL pin is ignored. 1b: Act on the CONTROL pin (and the (01h) OPERATION command) if configured by bit [3] to start or stop power conversion.
1	POLARITY	RW	NVM	0b: CONTROL pin has active low polarity. The UVLO function of the EN/UVLO pin cannot be used when CONTROL has active load polarity. 1b: The CONTROL pin has active high polarity.
0	DELAY	RW	NVM	0b: When power conversion is commanded OFF by the CONTROL pin (must be configured to respect the CONTROL pin as above), continue regulating for the (64h) TOFF_DELAY time, then ramp the output voltage to 0 V, in the time defined by (65h) TOFF_FALL. 1b: When power conversion is commanded OFF by the CONTROL pin (must be configured to respect the CONTROL pin as above), stop power conversion immediately.

For the purposes of (02h) ON\_OFF\_CONFIG, the device pin EN/UVLO is the CONTROL pin.

Attempts to write (02h) ON\_OFF\_CONFIG to any value other than those explicitly listed above are considered invalid or unsupported data and cause the TPSM8D6C24 to respond by flagging the appropriate status bits, and notifying the host according to the PMBus 1.3.1 Part II specification, section 10.9.3.

### 6.6.4 (03h) CLEAR\_FAULTS

CMD Address	03h
Write Transaction:	Send Byte
Read Transaction:	N/A
Format:	Data-less
Phased:	Yes
NVM Backup:	No
Updates:	On-the-fly

**CLEAR\_FAULTS** is a phased command used to clear any fault bits that have been set. This command simultaneously clears all bits in all status registers of the selected phase, or all phases if PHASE = FFh. At the same time, the device releases its SMB\_ALERT# signal output if SMB\_ALERT# is asserted. **CLEAR\_FAULTS** is a write-only command with no data.

The **CLEAR\_FAULTS** command does not cause a unit that has latched off for a fault condition to restart. If the fault is still present when the bit is cleared, the fault bit is immediately set again and the host is notified by the usual means.

If the device responds to an Alert Response Address (ARA) from the host, it clears SMB\_ALERT# but not the offending status bit or bits (as it has successfully notified the host and then expects the host to handle the interrupt appropriately). The original fault and any from other sources that occur between the initial assertion of SMB\_ALERT# and the successful response of the device to the ARA are cleared (through **CLEAR\_FAULTS**, OFF-ON toggle, or power reset) before any of these sources are allowed to re-trigger SMB\_ALERT#. However, fault sources that only become active post-ARA trigger SMB\_ALERT#.

**图 6-11. (03h) CLEAR\_FAULTS Register Map**

7	6	5	4	3	2	1	0
W	W	W	W	W	W	W	W
CLEAR_FAULTS							

LEGEND: R/W = Read/Write; R = Read only

### 6.6.5 (04h) PHASE

CMD Address	04h
Write Transaction:	Write Byte
Read Transaction:	Read Byte
Format:	Unsigned Binary (1 byte)
Phased:	No
NVM Backup:	No
Updates:	On-the-fly

The **PHASE** command provides the ability to configure, control, and monitor individual phases. Each **PHASE** contains the operating memory and user store and default store for each phase output. The phase selected by the **PHASE** command is used for all subsequent phase-dependent commands. The phase configuration needs to be established before any phase-dependent command can be successfully executed.

In the TPSM8D6C24, each **PHASE** is a separate device. The loop and PMBus loop controller device, GOSNS/FLWR connected to ground, is always PHASE = 00h. Loop follower devices, GOSNS/FLWR connected to BP1V5, have their phase assignment defined by their phase position, as defined by INTERLEAVE or MSEL2.

**图 6-12. (04h) PHASE Register Map**

7	6	5	4	3	2	1	0
RW	RW	RW	RW	RW	RW	RW	RW
PHASE							

LEGEND: R/W = Read/Write; R = Read only

**表 6-21. Register Field Descriptions**

Bit	Field	Access	Reset	Description
7:0	PHASE	RW	FFh	00h: All commands address Phase 1. 01h: All commands address Phase 2. 02h: All commands address Phase 3. 03h: All commands address Phase 4. 04h-FEh: Unsupported or invalid data FFh: Commands are addressed to all phases as a single entity. See the following text for more information.

The range of valid data for **PHASE** also depends on the phase configuration. Attempts to write (04h) **PHASE** to a value not supported by the current phase configuration are considered invalid or unsupported data and cause the TPSM8D6C24 to respond by flagging the appropriate status bits and notifying the host according to the PMBus 1.3.1 Part II specification, section 10.9.3.

### 6.6.6 (10h) WRITE\_PROTECT

CMD Address	10h
Write Transaction:	Write Byte
Read Transaction:	Read Byte
Format:	Unsigned Binary (1 byte)
Phased:	No
NVM Backup:	EEPROM
Updates:	On-the-fly

The [WRITE\\_PROTECT](#) command controls writing to the PMBus device. The intent of this command is to provide protection against accidental changes; it has one data byte that is described below. This command does *not* provide protection against deliberate or malicious changes to a configuration or operation of the device. All supported commands can have their parameters read, regardless of the [WRITE\\_PROTECT](#) settings.

图 6-13. (10h) WRITE\_PROTECT Register Map

7	6	5	4	3	2	1	0
RW	RW	RW	RW	RW	RW	RW	RW
WRITE_PROTECT							

LEGEND: R/W = Read/Write; R = Read only

表 6-22. Register Field Descriptions

Bit	Field	Access	Reset	Description
7:0	WRITE_PROTECT	RW	NVM	00h: Enable writes to all commands. 20h: Disables all write access except to the WRITE_PROTECT, OPERATION, ON_OFF_CONFIG, STORE_USER_ALL, and VOUT_COMMAND commands. 40h: Disables all WRITES except to the WRITE_PROTECT, OPERATION, and STORE_USER_ALL commands. 80h: Disables all WRITES except to the WRITE_PROTECT and STORE_USER_ALL commands. Other: Invalid/unsupported data

Attempts to write [\(10h\) WRITE\\_PROTECT](#) to any invalid value as specified above are considered invalid or unsupported data and cause the TPSM8D6C24 to respond by flagging the appropriate status bits, and notifying the host according to the PMBus 1.3.1 Part II specification, section 10.9.3.

### 6.6.7 (15h) STORE\_USER\_ALL

CMD Address	15h
Write Transaction:	Send Byte
Read Transaction:	N/A
Format:	Data-less
Phased:	No, PHASE = FFh only
NVM Backup:	No
Updates:	Not recommended for on-the-fly-use, but not explicitly blocked

The **STORE\_USER\_ALL** command instructs the PMBus device to copy the entire contents of the operating memory to the matching locations in the nonvolatile user store memory. Any items in operating memory that do not have matching locations in the user store are ignored.

NVM store operations are not recommended while the output voltages are in regulation, although the user is not explicitly prevented from doing so, as interruption can result in a corrupted NVM. PMBus commands issued during this time can cause long clock stretch times, or simply be ignored. TI recommends disabling regulation, and waiting a minimum of 100 ms before continuing, following issuance of NVM store operations.

To prevent storing mismatched register values to NVM, **STORE\_USER\_ALL** must not be used unless PHASE = FFh.

**图 6-14. (15h) STORE\_USER\_ALL Register Map**

7	6	5	4	3	2	1	0
W	W	W	W	W	W	W	W
STORE_USER_ALL							

LEGEND: R/W = Read/Write; R = Read only

### 6.6.8 (16h) RESTORE\_USER\_ALL

CMD Address	16h
Write Transaction:	Send Byte
Read Transaction:	N/A
Format:	Data-less
Phased:	No, PHASE = FFh only
NVM Backup:	No
Updates:	Disables Regulation during RESTORE

The [RESTORE\\_USER\\_ALL](#) command instructs the PMBus device to disable operation and copy the entire contents of the non-volatile user store memory to the matching locations in the operating memory, then overwrite the operating memory of any commands selected in PIN\_DETECT\_OVERRIDE with their last read pin-detected values. The values in the operating memory are overwritten by the value retrieved from the user store and pin detection. Any items in user store that do not have matching locations in the operating memory are ignored.

To prevent storing mismatched register values to NVM, RESTORE\_USER\_ALL must not be used unless PHASE = FFh.

图 6-15. (16h) RESTORE\_USER\_ALL Register Map

7	6	5	4	3	2	1	0
W	W	W	W	W	W	W	W
RESTORE_USER_ALL							

LEGEND: R/W = Read/Write; R = Read only

### 6.6.9 (19h) CAPABILITY

CMD Address	19h
Write Transaction:	N/A
Read Transaction:	Read Byte
Format:	Unsigned Binary (1 byte)
Phased:	No
NVM Backup:	No
Updates:	N/A

The **CAPABILITY** command provides a way for the host to determine the capabilities of this PMBus device. This command is read-only and has one data byte formatted as the following:

**图 6-16. (19h) CAPABILITY Register Map**

7	6	5	4	3	2	1	0
R	R	R	R	R	R	R	R
PEC	SPEED		ALERT	FORMAT	AVSBUS	0	0

LEGEND: R/W = Read/Write; R = Read only

**表 6-23. Register Field Descriptions**

Bit	Field	Access	Reset	Description
7	PEC	R	1b	1b: Packet Error Checking is supported.
6:5	SPEED	R	10b	10b: Maximum supported bus speed is 1 MHz.
4	ALERT	R	1b	1b: The device has an SMB_ALERT# pin and supports the SMBus Alert Response protocol.
3	FORMAT	R	0b	0b: Numeric format is LINEAR or DIRECT.
2	AVSBUS	R	0b	0b: AVSBus is NOT supported.
1:0	Reserved	R	00b	Reserved. Always set to 0.

Attempts to write **(19h) CAPABILITY** to any value are considered invalid or unsupported data and cause the TPSM8D6C24 to respond by flagging the appropriate status bits and notifying the host according to the PMBus 1.3.1 Part II specification, section 10.9.3.

### 6.6.10 (1Bh) SMBALERT\_MASK

CMD Address	1Bh
Write Transaction:	Write Word
Read Transaction:	Block-Write/Block-Read Process Call
Format:	Write: Unsigned Binary (2 bytes)Read: Unsigned Binary (1 byte)
Phased:	No, Only PHASE = FFh is supported
NVM Backup:	EEPROM
Updates:	On-the-fly

The [SMBALERT\\_MASK](#) command can be used to prevent a warning or fault condition from asserting the SMBALERT# signal. Setting a MASK bit does not prevent the associated bit in the STATUS\_CMD from being set, but prevents the associated bit in the STATUS\_CMD from asserting SMB\_ALERT#. See Reference [3] for more information on the command format. The following register descriptions describe the individual mask bits available.

SMBALERT\_MASK Write Transaction = Write Word. CMD = 1Bh, Low =STATUS\_CMD, High = MASK

SMBALERT\_MASK Read Transaction = Block-Write or Block-Read Process Call. Write 1 byte block with STATUS\_CMD, read 1 byte block.



### 6.6.11 (1Bh) SMBALERT\_MASK\_VOUT

CMD Address	1Bh (with CMD byte = 7Ah)
Write Transaction:	Write Word
Read Transaction:	Block-Write/Block-Read Process Call
Format:	Unsigned Binary (1 byte)
Phased:	No, Only PHASE = FFh is supported
NVM Backup:	EEPROM
Updates:	On-the-fly

SMBALERT\_MASK bits for the [STATUS\\_VOUT](#) command

**图 6-17. (1Bh) SMBALERT\_MASK\_VOUT Register Map**

7	6	5	4	3	2	1	0
RW	RW	RW	RW	RW	RW	R	R
mVOUT_OVF	mVOUT_OVW	mVOUT_UVW	mVOUT_UVF	mVOUT_MINMAX	mTON_MAX	0	0

LEGEND: R/W = Read/Write; R = Read only

**表 6-24. Register Field Descriptions**

Bit	Field	Access	Reset	Description
7	mVOUT_OVF	RW	NVM	0b: SMBALERT may assert due to this condition. 1b: SMBALERT may <i>not</i> assert due to this condition.
6	mVOUT_OVW	RW	NVM	0b: SMBALERT may assert due to this condition. 1b: SMBALERT may <i>not</i> assert due to this condition.
5	mVOUT_UVW	RW	NVM	0b: SMBALERT may assert due to this condition. 1b: SMBALERT may <i>not</i> assert due to this condition.
4	mVOUT_UVF	RW	NVM	0b: SMBALERT may assert due to this condition. 1b: SMBALERT may <i>not</i> assert due to this condition.
3	mVOUT_MINMAX	RW	NVM	0b: SMBALERT may assert due to this condition. 1b: SMBALERT may <i>not</i> assert due to this condition.
2	mTON_MAX	RW	NVM	0b: SMBALERT may assert due to this condition. 1b: SMBALERT may <i>not</i> assert due to this condition.
1:0	Not supported	R	00b	Not supported and always set to 00b.

### 6.6.12 (1Bh) SMBALERT\_MASK\_IOUT

CMD Address	1Bh (with CMD byte = 7Bh)
Write Transaction:	Write Word
Read Transaction:	Block-Write/Block-Read Process Call
Format:	Unsigned Binary (1 byte)
Phased:	No, Only PHASE = FFh is supported
NVM Backup:	EEPROM
Updates:	On-the-fly

SMBALERT\_MASK bits for [STATUS\\_IOUT](#)

图 6-18. (1Bh) SMBALERT\_MASK\_IOUT Register Map

7	6	5	4	3	2	1	0
RW	R	RW	R	R	R	R	R
mIOUT_OCF	0	mIOUT_OCW	mIOUT_UCF	0	0	0	0

LEGEND: R/W = Read/Write; R = Read only

表 6-25. Register Field Descriptions

Bit	Field	Access	Reset	Description
7	mIOUT_OCF	RW	NVM	0b: SMBALERT may assert due to this condition. 1b: SMBALERT may <i>not</i> assert due to this condition.
6	Not supported	R	0b	Not supported
5	mIOUT_OCW	RW	NVM	0b: SMBALERT may assert due to this condition. 1b: SMBALERT may <i>not</i> assert due to this condition.
4	mIOUT_UCF	RW	NVM	1b: SMBALERT may <i>not</i> assert due to this condition.
3	Not supported	R	0b	Not supported
2:0	Not supported	RW	0b	Not supported

### 6.6.13 (1Bh) SMBALERT\_MASK\_INPUT

CMD Address	1Bh (with CMD byte = 7Ch)
Write Transaction:	Write Word
Read Transaction:	Block-Write/Block-Read Process Call
Format:	Unsigned Binary (1 byte)
Phased:	No, Only PHASE = FFh is supported
NVM Backup:	EEPROM
Updates:	On-the-fly

SMBALERT\_MASK bits for STATUS\_INPUT

图 6-19. (1Bh) SMBALERT\_MASK\_INPUT Register Map

7	6	5	4	3	2	1	0
R	R	R	R	RW	R	R	R
0	0	0	0	mLOW_VIN	0	0	0

LEGEND: R/W = Read/Write; R = Read only

表 6-26. Register Field Descriptions

Bit	Field	Access	Reset	Description
7	Not supported	R	0b	Not supported
6	Not supported	R	0b	Not supported
5	Not supported	R	0b	Not supported
4	Not supported	R	0b	Not supported
3	mLOW_VIN	RW	NVM	0b: SMBALERT may assert due to this condition. 1b: SMBALERT may <i>not</i> assert due to this condition.
2	Not supported	R	0b	Not supported
1	Not supported	R	0b	Not supported
0	Not supported	R	0b	Not supported

### 6.6.14 (1Bh) SMBALERT\_MASK\_TEMPERATURE

CMD Address	1Bh (with CMD byte = 7Dh)
Write Transaction:	Write Word
Read Transaction:	Block-Write/Block-Read Process Call
Format:	Unsigned Binary (1 byte)
Phased:	No, Only PHASE = FFh is supported
NVM Backup:	EEPROM
Updates:	On-the-fly

### SMBALERT\_MASK bits for STATUS\_TEMPERATURE

图 6-20. (1Bh) SMBALERT\_MASK\_TEMPERATURE Register Map

7	6	5	4	3	2	1	0
RW	RW	R	R	R	R	R	R
mOTF	mOTW	0	0	0	0	0	0

LEGEND: R/W = Read/Write; R = Read only

表 6-27. Register Field Descriptions

Bit	Field	Access	Reset	Description
7	mOTF	RW	NVM	0b: SMBALERT may assert due to this condition. 1b: SMBALERT may <i>not</i> assert due to this condition.
6	mOTW	RW	NVM	0b: SMBALERT may assert due to this condition. 1b: SMBALERT may <i>not</i> assert due to this condition.
5:0	Not supported	R	0d	Not supported and always set to 000000b.

### 6.6.15 (1Bh) SMBALERT\_MASK\_CML

CMD Address	1Bh (with CMD byte = 7Eh)
Write Transaction:	Write Word
Read Transaction:	Block-Write/Block-Read Process Call
Format:	Unsigned Binary (1 byte)
Phased:	No, Only PHASE = FFh is supported
NVM Backup:	EEPROM
Updates:	On-the-fly

SMBALERT\_MASK bits for [STATUS\\_CML](#)

图 6-21. (1Bh) SMBALERT\_MASK\_CML Register Map

7	6	5	4	3	2	1	0
RW	RW	RW	RW	R	R	RW	R
mIVC	mIVD	mPEC	mMEM	0	0	mCOMM	0

LEGEND: R/W = Read/Write; R = Read only

表 6-28. Register Field Descriptions

Bit	Field	Access	Reset	Description
7	mIVC	RW	NVM	0b: SMBALERT may assert due to this condition. 1b: SMBALERT may <i>not</i> assert due to this condition.
6	mIVD	RW	NVM	0b: SMBALERT may assert due to this condition. 1b: SMBALERT may <i>not</i> assert due to this condition.
5	mPEC	RW	NVM	0b: SMBALERT may assert due to this condition. 1b: SMBALERT may <i>not</i> assert due to this condition.
4	mMEM	RW	NVM	0b: SMBALERT may assert due to this condition. 1b: SMBALERT may <i>not</i> assert due to this condition.
3:2	Not supported	R	00b	Not supported
1	mCOMM	RW	NVM	0b: SMBALERT may assert due to this condition. 1b: SMBALERT may <i>not</i> assert due to this condition.
0	Not supported	R	0b	Not supported

### 6.6.16 (1Bh) SMBALERT\_MASK\_OTHER

CMD Address	1Bh (with CMD byte = 7Fh)
Write Transaction:	Write Word
Read Transaction:	Block-Write/Block-Read Process Call
Format:	Unsigned Binary (1 byte)
Phased:	No
NVM Backup:	EEPROM
Updates:	On-the-fly

SMBALERT\_MASK bits for [STATUS\\_OTHER](#)

图 6-22. (1Bh) SMBALERT\_MASK\_OTHER Register Map

7	6	5	4	3	2	1	0
R	R	R	R	R	R	R	R
0	0	0	0	0	0	0	mFIRST_TO_ALERT

LEGEND: R/W = Read/Write; R = Read only

表 6-29. Register Field Descriptions

Bit	Field	Access	Reset	Description
7:1	Not supported	R	0h	Not supported
0	mFIRST_TO_ALERT	R	1b	The FIRST_TO_ALERT bit does not in itself generate SMBALERT assertion, hence this bit is hard-coded to 1b (source is masked).

### 6.6.17 (1Bh) SMBALERT\_MASK\_MFR

CMD Address	1Bh (with CMD byte = 80h)
Write Transaction:	Write Word
Read Transaction:	Block-Write/Block-Read Process Call
Format:	Unsigned Binary (1 byte)
Phased:	No
NVM Backup:	EEPROM
Updates:	On-the-fly

SMBALERT\_MASK bits for [STATUS\\_MFR](#)

图 6-23. (1Bh) SMBALERT\_MASK\_MFR Register Map

7	6	5	4	3	2	1	0
RW	RW	R	R	RW	RW	RW	R
mPOR	mSELF	0	0	mRESET	mBCX	mSYNC	0

LEGEND: R/W = Read/Write; R = Read only

表 6-30. Register Field Descriptions

Bit	Field	Access	Reset	Description
7	mPOR	RW	NVM	0b: SMBALERT may assert due to this condition. 1b: SMBALERT may <i>not</i> assert due to this condition.
6	mSELF	RW	NVM	0b: SMBALERT may assert due to this condition. 1b: SMBALERT may <i>not</i> assert due to this condition. Due to variations in AVIN UVLO, unmasking this bit can result in SMBALERT being asserted on power up.
5	Not supported	R	0b	Not supported
4	Not supported	R	0b	Not supported
3	mRESET	RW	NVM	0b: SMBALERT may assert due to this condition. 1b: SMBALERT may <i>not</i> assert due to this condition.
2	mBCX	RW	NVM	0b: SMBALERT may assert due to this condition. 1b: SMBALERT may <i>not</i> assert due to this condition.
1	mSYNC	RW	NVM	0b: SMBALERT may assert due to this condition. 1b: SMBALERT may <i>not</i> assert due to this condition. When the loop controller device of a multi-phase stack is programmed for Auto Detect SYNC, unmasking this bit can result in a momentary assertion of SMBALERT when the multi-phase stack is enabled.
0	Not supported	R	0b	Not supported

### 6.6.18 (20h) VOUT\_MODE

CMD Address	20h
Write Transaction:	Write Byte
Read Transaction:	Read Byte
Format:	Unsigned Binary (1 byte)
Phased:	No
NVM Backup:	EEPROM
Updates:	Conversion Disabled: on-the-fly, Conversion Enabled: Read Only

The data byte for the [VOUT\\_MODE](#) command is one byte that consists of a three bit mode and a five bit parameter as shown in [图 6-24](#). The three bit mode sets whether the device uses the ULINEAR16, half-precision IEEE 754 floating point, or VID or DIRECT modes for output voltage related commands. The five bit parameter provides more information about the selected mode, such as the ULINEAR16 exponent or which manufacturer's VID codes are being used.

**图 6-24. (20h) VOUT\_MODE Register Map**

7	6	5	4	3	2	1	0
RW	R	R	RW	RW	RW	RW	RW
REL	MODE		PARAMETER				

LEGEND: R/W = Read/Write; R = Read only

**表 6-31. Register Field Descriptions**

Bit	Field	Access	Reset	Description
7	REL	RW	NVM	0b: Absolute Data Format 1b: Relative Data Format
6:5	MODE	R	00b	00b: Linear Format (ULINEAR16, SLINEAR16) Other: Unsupported or invalid
4:0	PARAMETER	RW	NVM	MODE = 00b (Linear Format): Specifies the exponent “N” to use with output voltage related commands, in two’s complement format. Supported exponent values in the linear mode range from - 4 (62.5 mV/LSB) to - 12 (0.244 mV/LSB). Refer to the following text for more information.

### Changing VOUT\_MODE

Changing [VOUT\\_MODE](#) forces an update to the values of many VOUT related commands to conform to the updated [VOUT\\_MODE](#) value including relative versus absolute mode and the linear exponent value. When programming VOUT\_MODE in conjunction with other VOUT related commands, VOUT related commands are interpreted with the current [VOUT\\_MODE](#) value and converted if [VOUT\\_MODE](#) is later changed.



### 6.6.19 (21h) VOUT\_COMMAND

CMD Address	21h
Write Transaction:	Write Word
Read Transaction:	Read Word
Format:	ULINEAR16, Absolute Only per <a href="#">VOUT_MODE</a>
Phased:	No
NVM Backup:	EEPROM or Pin Detection
Updates:	On-the-fly

[VOUT\\_COMMAND](#) causes the device to set its output voltage to the commanded value with two data bytes. Output voltage changes due to [VOUT\\_COMMAND](#) occur at the rate specified by [VOUT\\_TRANSITION\\_RATE](#).

When PGD/RST\_B is configured as a RESET# pin in MISC\_OPTIONS, assertion of the PGD/RST\_B pin causes the output voltage to return to the VBOOT value, and causes the [VOUT\\_COMMAND](#) value to be updated accordingly.

图 6-25. (21h) VOUT\_COMMAND Register Map

15	14	13	12	11	10	9	8
RW	RW	RW	RW	RW	RW	RW	RW
VOUT_COMMAND (High Byte)							
7	6	5	4	3	2	1	0
RW	RW	RW	RW	RW	RW	RW	RW
VOUT_COMMAND (Low Byte)							

LEGEND: R/W = Read/Write; R = Read only

表 6-32. Register Field Descriptions

Bit	Field	Access	Reset	Description
15:0	VOUT_COMMAND	RW	NVM	Sets the output voltage target through the PMBus interface.

At power up, the reset value of [VOUT\\_COMMAND](#) is derived from either pin-detection on the VSEL pin, or from the NVM, depending on the VOUT\_COMMAND bit in PIN\_DETECT\_OVERRIDE.

When the VOUT\_COMMAND bit in PIN\_DETECT\_OVERRIDE = 0b, the default value of [VOUT\\_COMMAND](#) is restored from NVM at power-on reset or RESTORE\_USER\_ALL.

When the VOUT\_COMMAND bit in PIN\_DETECT\_OVERRIDE = 1b, the default value of [VOUT\\_COMMAND](#) is derived from pin-detection on the VSEL pin, at power-on reset or RESTORE\_USER\_ALL.

This default value, whether derived from pin detection, or NVM becomes the “default” output voltage (also referred to as “VBOOT” ), and is stored in RAM separately from the current value of [VOUT\\_COMMAND](#).

#### BOOT Voltage Behavior

The RESET\_FLT bit in MISC\_OPTIONS selects the [VOUT\\_COMMAND](#) behavior following a fault-related shutdown. When RESET\_FLT = 0b, the device retains the current value of [VOUT\\_COMMAND](#) during HICCUP after a fault. When RESET\_FLT = 1b, [VOUT\\_COMMAND](#) will reset to the last detected VSEL voltage or the NVM STORED value for [VOUT\\_COMMAND](#) as selected by the VOUT\_COMMAND bit in MISC\_OPTIONS.

#### Data Validity

Writes to [VOUT\\_COMMAND](#) for which the resulting value, including any offset from [VOUT\\_TRIM](#) is greater than the current [VOUT\\_MAX](#) or less than the current [VOUT\\_MIN](#), causes the reference DAC to move to the value specified by [VOUT\\_MIN](#) or [VOUT\\_MAX](#) respectively, and causes the VOUT\_MAX\_MIN\_WARNING fault

condition, setting the appropriate bits in [STATUS\\_WORD](#), [STATUS\\_VOUT](#) and notifying the host per the PMBus 1.3.1 Part II specification, section 10.2.

### 6.6.20 (22h) VOUT\_TRIM

CMD Address	22h
Write Transaction:	Write Word
Read Transaction:	Read Word
Format:	SLINEAR16, absolute only per (20h) VOUT_MODE.
Phased:	No
NVM Backup:	EEPROM
Updates:	On-the-fly

VOUT\_TRIM is used to apply a fixed offset voltage to the output voltage command value. Output voltage changes due to VOUT\_TRIM occur at the rate specified by (27h) VOUT\_TRANSITION\_RATE.

图 6-26. (22h) VOUT\_TRIM Register Map

15	14	13	12	11	10	9	8
RW	RW	RW	RW	RW	RW	RW	RW
VOUT_TRIM (High Byte)							
7	6	5	4	3	2	1	0
RW	RW	RW	RW	RW	RW	RW	RW
VOUT_TRIM (Low Byte)							

LEGEND: R/W = Read/Write; R = Read only

表 6-33. Register Field Descriptions

Bit	Field	Access	Reset	Description
15:0	VOUT_TRIM	RW	See Below	Output voltage offset. SLINEAR16 (two's complement) format

#### Limited NVM Backup

Only 8 bits of NVM backup are provided for this command. While the VOUT\_TRIM command follows the (20h) VOUT\_MODE exponent, NVM backup is stored with an exponent -12 and stored values are limited to +127 to -128 with an exponent -12 irrespective of (20h) VOUT\_MODE.

#### Data Validity

Referring to the data validity table in (21h) VOUT\_COMMAND (reproduced below), the output voltage value (including any offset from VOUT\_TRIM, VOUT\_COMMAND, VOUT\_MARGIN, ...) may not exceed the values supported by the DAC hardware.

Programming a (21h) VOUT\_COMMAND + (22h) VOUT\_TRIM value greater than the maximum value supported by the DAC hardware but less than (24h) VOUT\_MAX result in the regulated output voltage clamping at the maximum value supported by the DAC hardware without setting the VOUT\_MAX\_MIN bit in (7Ah) STATUS\_VOUT.

表 6-34. VOUT\_COMMAND / VOUT\_MARGIN + VOUT\_TRIM Data Validity (Linear Format)

VOUT_SCALE_LOOP	Internal Divider	Valid VOUT_COMMAND / Margin + VOUT_TRIM Values
1.0	None	0.000V to 0.700 V
0.5	1:1	0.000 V to 1.400 V
0.25	1:3	0.000 V to 2.800 V
0.125	1:7	0.000 V to 6.000 V

The minimum and maximum valid data values for [VOUT\\_TRIM](#) follow the description in [\(21h\) VOUT\\_COMMAND](#). Attempts to write [VOUT\\_TRIM](#) to any value outside those specified as valid are considered invalid or unsupported data and cause the TPSM8D6C24 to respond by flagging the appropriate status bits, and notifying the host according to the PMBus 1.3.1 Part II specification section 10.9.3.

Writes to [VOUT\\_TRIM](#) for which the resulting output voltage is greater than the current [\(24h\) VOUT\\_MAX](#), or less than the current [\(2Bh\) VOUT\\_MIN](#), cause the reference DAC to move to the value specified by [\(2Bh\) VOUT\\_MIN](#) or [\(24h\) VOUT\\_MAX](#), respectively, and cause the VOUT\_MAX\_MIN\_WARNING fault condition, setting the appropriate bits in [\(79h\) STATUS\\_WORD](#) and [\(7Ah\) STATUS\\_VOUT](#) and notifying the host per the PMBus 1.3.1 Part II specification, section 10.2.

### 6.6.21 (24h) VOUT\_MAX

CMD Address	24h
Write Transaction:	Write Word
Read Transaction:	Read Word
Format:	ULINEAR16, Absolute Only per <a href="#">VOUT_MODE</a>
Phased:	No
NVM Backup:	EEPROM or Pin Detection
Updates:	On-the-fly

The [VOUT\\_MAX](#) command sets an upper limit on the output voltage the unit and can command regardless of any other commands or combinations. The intent of this command is to provide a safeguard against a user accidentally setting the output voltage to a possibly destructive level.

图 6-27. (24h) VOUT\_MAX Register Map

15	14	13	12	11	10	9	8
RW	RW	RW	RW	RW	RW	RW	RW
VOUT_MAX (High Byte)							
7	6	5	4	3	2	1	0
RW	RW	RW	RW	RW	RW	RW	RW
VOUT_MAX (Low Byte)							

LEGEND: R/W = Read/Write; R = Read only

表 6-35. Register Field Descriptions

Bit	Field	Access	Reset	Description
15:0	VOUT_MAX	RW	NVM	Maximum output voltage. ULINEAR16 absolute per the setting of <a href="#">VOUT_MODE</a> . Refer to the following description for data validity.

While conversion is enabled, any output voltage change (including [VOUT\\_COMMAND](#), [VOUT\\_TRIM](#), and margin operations) that causes the new target voltage to be greater than the current value of [VOUT\\_MAX](#) cause the [VOUT\\_MAX\\_MIN\\_WARNING](#) fault condition. This result causes the TPSM8D6C24 to:

- Set to the output voltage to current value of [VOUT\\_MAX](#), at the slew rate defined by [VOUT\\_TRANSITION\\_RATE](#).
- Set the NONE OF THE ABOVE bit in the [STATUS\\_BYTE](#).
- Set the VOUT bit in the [STATUS\\_WORD](#).
- Set the VOUT\_MIN\_MAX warning bit in [STATUS\\_VOUT](#).
- Notify the host per PMBus 1.3.1 Part II specification, section 10.2.

Although the scenario is uncommon, note that the same response results if the user attempted to program [VOUT\\_MAX](#) less than the current output voltage target.

### 6.6.22 (25h) VOUT\_MARGIN\_HIGH

CMD Address	25h
Write Transaction:	Write Word
Read Transaction:	Read Word
Format:	ULINEAR16, per <a href="#">VOUT_MODE</a>
Phased:	No
NVM Backup:	EEPROM
Updates:	On-the-fly

The [VOUT\\_MARGIN\\_HIGH](#) command loads the unit with the voltage to which the output is to be changed when the [OPERATION](#) command is set to “Margin High.” Output voltage transitions during margin operation occur at the slew rate defined by [VOUT\\_TRANSITION\\_RATE](#).

When the MARGIN bits in the [OPERATION](#) command indicate “Margin High,” the output voltage is updated to the value of [VOUT\\_MARGIN\\_HIGH](#) + [VOUT\\_TRIM](#).

图 6-28. (25h) VOUT\_MARGIN\_HIGH Register Map

15	14	13	12	11	10	9	8
RW	RW	RW	RW	RW	RW	RW	RW
VOUT_MARGH (High Byte)							
7	6	5	4	3	2	1	0
RW	RW	RW	RW	RW	RW	RW	RW
VOUT_MARGH (Low Byte)							

LEGEND: R/W = Read/Write; R = Read only

表 6-36. Register Field Descriptions

Bit	Field	Access	Reset	Description
15:0	VOUT_MARGH	RW	NVM	Margin High output voltage. ULINEAR16 relative or absolute per the setting of VOUT_MODE

The minimum and maximum valid data values for [VOUT\\_MARGIN\\_HIGH](#) follow the description in [VOUT\\_COMMAND](#). That is, the total combined output voltage, including [VOUT\\_MARGIN\\_HIGH](#) and [VOUT\\_TRIM](#), follow the values allowed by the current [VOUT\\_MAX](#) setting.

Attempts to write (25h) [VOUT\\_MARGIN\\_HIGH](#) to any value outside those specified as valid are considered invalid or unsupported data and cause the TPSM8D6C24 to respond by flagging the appropriate status bits and notifying the host according to the PMBus 1.3.1 Part II specification section 10.9.3.

### 6.6.23 (26h) VOUT\_MARGIN\_LOW

CMD Address	26h
Write Transaction:	Write Word
Read Transaction:	Read Word
Format:	ULINEAR16, per <a href="#">VOUT_MODE</a>
Phased:	No
NVM Backup:	EEPROM

The [VOUT\\_MARGIN\\_LOW](#) command loads the unit with the voltage to which the output is to be changed when the [OPERATION](#) command is set to “Margin Low.” Output voltage transitions during margin operation occur at the slew rate defined by [VOUT\\_TRANSITION\\_RATE](#).

When the MARGIN bits in the [OPERATION](#) command indicate “Margin Low,” the output voltage is updated to the value of [VOUT\\_MARGIN\\_LOW](#) + [VOUT\\_TRIM](#).

**图 6-29. (26h) VOUT\_MARGIN\_LOW Register Map**

15	14	13	12	11	10	9	8
RW	RW	RW	RW	RW	RW	RW	RW
VOUT_MARGIN_LOW (High Byte)							
7	6	5	4	3	2	1	0
RW	RW	RW	RW	RW	RW	RW	RW
VOUT_MARGIN_LOW (Low Byte)							

LEGEND: R/W = Read/Write; R = Read only

**表 6-37. Register Field Descriptions**

Bit	Field	Access	Reset	Description
15:0	VOUT_MARGL	RW	NVM	Margin Low output voltage. ULINEAR16 relative or absolute per the setting of VOUT_MODE

The minimum and maximum valid data values for [VOUT\\_MARGIN\\_LOW](#) follow the description in [VOUT\\_COMMAND](#). Attempts to write [\(26h\) VOUT\\_MARGIN\\_LOW](#) to any value outside those specified as valid are considered invalid or unsupported data and cause the TPSM8D6C24 to respond by flagging the appropriate status bits and notifying the host according to the PMBus 1.3.1 Part II specification section 10.9.3.

### 6.6.24 (27h) VOUT\_TRANSITION\_RATE

CMD Address	27h
Write Transaction:	Write Word
Read Transaction:	Read Word
Format:	SLINEAR11 per <a href="#">CAPABILITY</a>
Phased:	No
NVM Backup:	EEPROM
Updates:	On-the-fly

The [VOUT\\_TRANSITION\\_RATE](#) command sets the slew rate at which any output voltage changes during normal power conversion occur. This commanded rate of change does not apply when the unit is commanded to turn on or to turn off. The units are mV/  $\mu$ s.

图 6-30. (27h) VOUT\_TRANSITION\_RATE Register Map

15	14	13	12	11	10	9	8
RW	RW	RW	RW	RW	RW	RW	RW
VOTR_EXP					VOTR_MAN		
7	6	5	4	3	2	1	0
RW	RW	RW	RW	RW	RW	RW	RW
VOTR_MAN							

LEGEND: R/W = Read/Write; R = Read only

表 6-38. Register Field Descriptions

Bit	Field	Access	Reset	Description
15:11	VOTR_EXP	RW	11100b	Linear format two' s complement exponent. Exponent = - 4, LSB = 0.0625 mV/ $\mu$ s
10:0	VOTR_MAN	RW	NVM	Linear format two' s complement mantissa

Note that every binary value between the minimum and maximum values is writable and readable, but that the actual output voltage slew rate is set to the nearest supported value.

VOUT\_TRANSITION RATE can be programmed from 0.067 mV/ $\mu$ s to 15.933 mV/ $\mu$ s.

Attempts to write [\(27h\) VOUT\\_TRANSITION\\_RATE](#) to any value outside those specified as valid are considered invalid or unsupported data and cause the TPSM8D6C24 to respond by flagging the appropriate status bits and notifying the host according to the PMBus 1.3.1 Part II specification section 10.9.3.



### 6.6.25 (29h) VOUT\_SCALE\_LOOP

CMD Address	29h
Write Transaction:	Write Word
Read Transaction:	Read Word
Format:	SLINEAR11 per <a href="#">CAPABILITY</a>
Phased:	No
Updates:	Conversion Disable: on-the-fly. Conversion Enable: hardware update blocked. To update hardware after write while enabled, store to NVM with STORE_USER_ALL and RESTORE_USER_ALL or cycle AVIN below UVLO.
NVM Backup:	EEPROM or Pin Detection

The VOUT\_SCALE\_LOOP command allows PMBus devices to map between the commanded voltage and the voltage at the control circuit input. In the TPSM8D6C24, VOUT\_SCALE\_LOOP also programs an internal precision resistor divider so no external divider is required.

图 6-31. (29h) VOUT\_SCALE\_LOOP Register Map

15	14	13	12	11	10	9	8
RW	RW	RW	RW	RW	RW	RW	RW
VOSL_EXP				VOSL_MAN			
7	6	5	4	3	2	1	0
RW	RW	RW	RW	RW	RW	RW	RW
VOSL_MAN							

LEGEND: R/W = Read/Write; R = Read only

表 6-39. Register Field Descriptions

Bit	Field	Access	Reset	Description
15:11	VOSL_EXP	RW	11001b	Linear format two' s complement exponent
10:0	VOSL_MAN	RW	NVM	Linear format two' s complement mantissa

#### Data Validity

Every binary value between the minimum and maximum supported values is writable and readable. However, not every combination is supported in hardware. Refer to [表 6-40](#):

表 6-40. Accepted Values

VOUT_SCALE_LOOP (DECODED)	Internal Divider Scaling Factor
Less than or equal to 0.125	0.125
$0.125 < \text{VOSL} \leq 0.25$	0.25
$0.25 < \text{VOSL} \leq 0.5$	0.5
Greater than 0.5	1.0

Attempts to write (29h) VOUT\_SCALE\_LOOP to any value outside those specified as valid are considered invalid or unsupported data and cause the TPSM8D6C24 to respond by flagging the appropriate status bits and notifying the host according to the PMBus 1.3.1 Part II specification section 10.9.3.

If a (29h) VOUT\_SCALE\_LOOP value other than a supported internal divider scaling factor is programmed into (29h) VOUT\_SCALE\_LOOP and (21h) VOUT\_COMMAND to VREF scale factors are calculated based on the actual (29h) VOUT\_SCALE\_LOOP value. (29h) VOUT\_SCALE\_LOOP values other than supported internal

divider scaling factors can produce a mismatch between (21h) [VOUT\\_COMMAND](#) and the actual commanded output voltage.

### 6.6.26 (2Bh) VOUT\_MIN

CMD Address	2Bh
Write Transaction:	Write Word
Read Transaction:	Read Word
Format:	ULINEAR16, absolute Only per <a href="#">VOUT_MODE</a>
Phased:	No
Updates:	On-the-fly
NVM Backup:	EEPROM or Pin Detection

The [VOUT\\_MIN](#) command sets a lower limit on the output voltage the unit can command regardless of any other commands or combinations. The intent of this command is to provide a safeguard against a user accidentally setting the output voltage to a level that renders the load inoperable.

图 6-32. (2Bh) VOUT\_MIN Register Map

15	14	13	12	11	10	9	8
RW	RW	RW	RW	RW	RW	RW	RW
VOUT_MIN (High Byte)							
7	6	5	4	3	2	1	0
RW	RW	RW	RW	RW	RW	RW	RW
VOUT_MIN (Low Byte)							

LEGEND: R/W = Read/Write; R = Read only

表 6-41. Register Field Descriptions

Bit	Field	Access	Reset	Description
15:0	VOUT_MIN	RW	NVM	Minimum output voltage. ULINEAR16 absolute per the setting of <a href="#">VOUT_MODE</a> .

During power conversion, any output voltage change (including [VOUT\\_COMMAND](#), [VOUT\\_TRIM](#), and margin operations) that causes the new target voltage to be less than the current value of [VOUT\\_MIN](#) causes the [VOUT\\_MAX\\_MIN\\_WARNING](#) fault condition. These results cause the TPSM8D6C24 to:

- Set to the output voltage to current value of [VOUT\\_MIN](#) at the slew rate defined by [VOUT\\_TRANSITION\\_RATE](#).
- Set the NONE OF THE ABOVE in the [STATUS\\_BYTE](#).
- Set the VOUT bit in the [STATUS\\_WORD](#).
- Set the VOUT\_MIN\_MAX warning bit in [STATUS\\_VOUT](#).
- Notify the host per PMBus 1.3.1 Part II specification, section 10.2.

Although the scenario is uncommon, note that the same response results if the user attempted to program [VOUT\\_MAX](#) greater than the current output voltage target.

#### Data Validity

The minimum and maximum valid data values for [VOUT\\_MIN](#) follow those of [VOUT\\_MAX](#). Attempts to write (2Bh) [VOUT\\_MIN](#) to any value outside those specified as valid are considered invalid or unsupported data and cause the TPSM8D6C24 to respond by flagging the appropriate status bits and notifying the host according to the PMBus 1.3.1 Part II specification section 10.9.3.

### 6.6.27 (33h) FREQUENCY\_SWITCH

CMD Address	33h
Write Transaction:	Write Word
Read Transaction:	Read Word
Format:	SLINEAR11, per <a href="#">CAPABILITY</a>
Phased:	No
Updates:	Conversion Disable: on-the-fly. Conversion Enable: hardware update blocked. To update hardware after write while enabled, store to NVM with STORE_USER_ALL and RESTORE_USER_ALL or cycle AVIN below UVLO.
NVM Backup:	EEPROM or Pin Detection

FREQUENCY\_SWITCH sets the switching frequency of the active channel in kHz.

图 6-33. (33h) FREQUENCY\_SWITCH Register Map

15	14	13	12	11	10	9	8
RW	RW	RW	RW	RW	RW	RW	RW
FSW_EXP				FSW_MAN			
7	6	5	4	3	2	1	0
RW	RW	RW	RW	RW	RW	RW	RW
FSW_MAN							

LEGEND: R/W = Read/Write; R = Read only

表 6-42. Register Field Descriptions

Bit	Field	Access	Reset	Description
15:11	FSW_EXP	RW	NVM	Linear format two' s complement exponent On reset, FSW_EXP is auto-generated based on the switching frequency stored in NVM.
10:0	FSW_MAN	RW	NVM	Linear format two' s complement mantissa. Refer to <a href="#">表 6-43</a> .

表 6-43. Supported Switching Frequency Settings

FREQUENCY_SWITCH (Decoded)	Effective Switching Frequency (kHz)
Less than 250 kHz	225
$251 \leq \text{FSW} < 300$ kHz	275
$301 \leq \text{FSW} < 350$ kHz	325
$351 \leq \text{FSW} < 410$ kHz	375
$411 \leq \text{FSW} < 500$ kHz	450
$501 \leq \text{FSW} < 600$ kHz	550
$601 \leq \text{FSW} < 700$ kHz	650
$701 \leq \text{FSW} < 820$ kHz	750
$821 \leq \text{FSW} < 1000$ kHz	900
$1001 \leq \text{FSW} < 1200$ kHz	1100
$1201 \leq \text{FSW} < 1400$ kHz	1300
$1401 \leq \text{FSW} < 1650$ kHz	1500

FREQUENCY\_SWITCH values greater than 1100 kHz can require higher VDD5 current than can be provided by the internal AVIN to VDD5 linear regulator. Programming FREQUENCY\_SWITCH to a value greater than 1100

kHz without an external source to VDD5 can result in repeated start-up and shutdown attempt. FRQUENCY\_SWITCH values greater than 1100 kHz are not recommended for stacked multi-phase operation.

### 6.6.28 (35h) VIN\_ON

CMD Address	35h
Write Transaction:	Write Word
Read Transaction:	Read Word
Format:	SLINEAR11, per <a href="#">CAPABILITY</a>
Phased:	No
NVM Backup:	EEPROM
Updates:	On-the-fly

The [VIN\\_ON](#) command sets the value of the input voltage, in Volts, at which the unit starts power conversion.

图 6-34. (35h) VIN\_ON Register Map

15	14	13	12	11	10	9	8
RW	RW	RW	RW	RW	RW	RW	RW
VON_EXP				VON_MAN			
7	6	5	4	3	2	1	0
RW	RW	RW	RW	RW	RW	RW	RW
VON_MAN							

LEGEND: R/W = Read/Write; R = Read only

表 6-44. Register Field Descriptions

Bit	Field	Access	Reset	Description
15:11	VON_EXP	RW	11110b	Linear format two' s complement exponent, - 2
10:0	VON_MAN	RW	NVM	Linear format two' s complement mantissa. Refer to the following text for more information.

Attempts to write [\(35h\) VIN\\_ON](#) to any value outside those specified as valid are considered invalid or unsupported data and cause the TPSM8D6C24 to respond by flagging the appropriate status bits and notifying the host according to the PMBus 1.3.1 Part II specification section 10.9.3.

#### Command Resolution and NVM Store or Restore Behavior

[\(35h\) VIN\\_ON](#) and [\(36h\) VIN\\_OFF](#) have limited hardware range and resolution as well as limited NVM allocation. While the command accepts any binary value within the valid range, values not exactly represented by the hardware resolution are rounded down to the next lower supported threshold for implementation or upon restore from NVM during power-on reset or [\(16h\) RESTORE\\_USER\\_ALL](#). [\(35h\) VIN\\_ON](#) hardware supports all values from 2.50 V to 18.25 in 0.25-V steps.

Note that the LOW\_VIN fault condition is masked until the sensed input voltage exceeds the [VIN\\_ON](#) threshold for the first time following a power-on reset. The Control/Enable pin toggles and EEPROM store and restore operations do not reset this masking.

### 6.6.29 (36h) VIN\_OFF

CMD Address	36h
Write Transaction:	Write Word
Read Transaction:	Read Word
Format:	SLINEAR11, per <a href="#">CAPABILITY</a>
Phased:	No
NVM Backup:	EEPROM
Updates:	On-the-fly

The (36h) [VIN\\_OFF](#) command sets the value of the PVIN input voltage, in Volts, at which the unit should stop power conversion. If the power conversion enable conditions as defined by (02h) [ON\\_OFF\\_CONFIG](#) are met and PVIN is less than (36h) [VIN\\_OFF](#), the output off due to low VIN bit in (7Ch) [STATUS\\_INPUT](#) is set.

图 6-35. (36h) VIN\_OFF Register Map

15	14	13	12	11	10	9	8
RW	RW	RW	RW	R	RW	RW	RW
VOFF_EXP				VOFF_MAN			
7	6	5	4	3	2	1	0
RW	RW	RW	RW	RW	RW	RW	RW
VOFF_MAN							

LEGEND: R/W = Read/Write; R = Read only

表 6-45. Register Field Descriptions

Bit	Field	Access	Reset	Description
15:11	VOFF_EXP	RW	11110b	Linear format two' s complement exponent
10:0	VOFF_MAN	RW	NVM	Linear format two' s complement mantissa. Refer to the following text.

Attempts to write (36h) [VIN\\_OFF](#) to any value outside those specified as valid are considered invalid or unsupported data and cause the TPSM8D6C24 to respond by flagging the appropriate status bits and notifying the host according to the PMBus 1.3.1 Part II specification section 10.9.3.

#### Command Resolution and NVM Store or Restore Behavior

(35h) [VIN\\_ON](#) and (36h) [VIN\\_OFF](#) have limited hardware range and resolution as well as limited NVM allocation. While the command will accept any binary value within the valid range, values not exactly represented by the hardware resolution will be rounded down to the next lower supported threshold for implementation or upon restoration from NVM during Power-On Reset or (16h) [RESTORE\\_USER\\_ALL](#). (36h) [VIN\\_OFF](#) hardware supports all values from 2.25 V to 18.25 in 0.25-V steps.

While it is possible to set (36h) [VIN\\_OFF](#) equal to or greater than (35h) [VIN\\_ON](#), it is not advisable and can produce rapid enabling and disabling of conversion and undesirable operation.

### 6.6.30 (37h) INTERLEAVE

CMD Address	37h
Write Transaction:	Write Word (Single Phase Only)
Read Transaction:	Read Word
Format:	Four Hexadecimal values
Phased:	No, Read only in Multi-phase stack
Updates:	On-the-fly
NVM Backup:	EEPROM or Pin Detection

The **INTERLEAVE** command sets the phase delay between the external SYNC (IN or OUT) and the internal PMW oscillator.

图 6-36. (37h) INTERLEAVE Register Map

15	14	13	12	11	10	9	8
R	R	R	R	RW	RW	RW	RW
Not Used				GROUPID			
7	6	5	4	3	2	1	0
RW	RW	RW	RW	RW	RW	RW	RW
NUM_GROUP				ORDER			

LEGEND: R/W = Read/Write; R = Read only

表 6-46. Register Field Descriptions

Bit	Field	Access	Reset	Description
15:12	Not Used	R	0h	Not used. Set to b'0000.
11:8	GROUPID	RW	NVM	Group ID Number. Set to 0h to Fh.
7:4	NUM_GROUP	RW	NVM	Number in Group. Sets the number of phases positions and the phase shift for each value of ORDER. Set to value 1h to 4h.
3:0	ORDER	RW	NVM	Order within the group. Each value of ORDER adds a phase shift equal to $360^\circ / \text{NUM\_GROUP}$ . Set to value 0h to $\text{NUM\_GROUP} - 1$ .

表 6-47. Supported INTERLEAVE Settings

Number in Group	Order	Phase Position (°)
1	0	0
2	0	0
2	1	180
3	0	0
3	1	120
3	2	240
4	0	0
4	1	90
4	2	180
4	3	270

The **(37h) INTERLEAVE** command is used to arrange multiple devices sharing a common SYNC signal in time. The phase delay added to each device is equal to  $360^\circ / \text{Number in Group} \times \text{Order}$ . To prevent misaligning the phases of a multi-phase stack, **(37h) INTERLEAVE** is read only when the TPSM8D6C24 is configured as part of a multi-phase stack. The Read/Write status of the **(37h) INTERLEAVE** command is set based on the state of the **(ECh) MFR\_SPECIFIC\_28 (STACK\_CONFIG)** command at power-on and is not updated if **(ECh)**



[MFR\\_SPECIFIC\\_28 \(STACK\\_CONFIG\)](#) is later changed. If [\(37h\) INTERLEAVE](#) is used to program the phase position of a standalone device, the TPSM8D6C24 must be configured as a standalone device at power-on to ensure write capability of the [\(37h\) INTERLEAVE](#) command.

### 6.6.31 (38h) IOUT\_CAL\_GAIN

CMD Address	38h
Write Transaction:	Write Word
Read Transaction:	Read Word
Format:	SLINEAR11, per <a href="#">CAPABILITY</a>
Phased:	No
NVM Backup:	EEPROM
Updates:	On-the-fly

(38h) [IOUT\\_CAL\\_GAIN](#) is used to trim the gain of the output current reported by the [READ\\_IOUT](#) command. The value is a unitless gain factor applied to the internally sensed current measurement. The register defaults to a value of 1.

图 6-37. (38h) IOUT\_CAL\_GAIN Register Map

15	14	13	12	11	10	9	8
RW	RW	RW	RW	RW	RW	RW	RW
IOCG_EXP					IOCG_MAN		
7	6	5	4	3	2	1	0
RW	RW	RW	RW	RW	RW	RW	RW
IOCG_MAN							

LEGEND: R/W = Read/Write; R = Read only

表 6-48. Register Field Descriptions

Bit	Field	Access	Reset	Description
15:11	IOCG_EXP	RW	11001b	Linear format, two' s complement exponent
10:0	IOCG_MAN	RW	NVM	Linear format, two' s complement mantissa

Attempts to write (38h) [IOUT\\_CAL\\_GAIN](#) to any value outside those specified as valid are considered invalid or unsupported data and cause the TPSM8D6C24 to respond by flagging the appropriate status bits and notifying the host according to the PMBus 1.3.1 Part II specification section 10.9.3.

#### Command Resolution and NVM Store or Restore Behavior

The (38h) [IOUT\\_CAL\\_GAIN](#) command is implemented using the TPSM8D6C24 internal telemetry system. As a result, the value of this command can be programmed with very high resolution using the linear format. However, the TPSM8D6C24 provides only limited NVM-backed options for this command. Following a power-cycle or NVM Store or Restore operation, the value is rounded to the nearest 1 / 64 with a maximum supported value of 1.984 (1 63 / 64).

### 6.6.32 (39h) IOUT\_CAL\_OFFSET

CMD Address	39h
Write Transaction:	Write Word
Read Transaction:	Read Word
Format:	SLINEAR11, per <a href="#">CAPABILITY</a>
Phased:	Yes
NVM Backup:	EEPROM
Updates:	On-the-fly

IOUT\_CAL\_OFFSET is used to compensate for offset errors in the [READ\\_IOUT](#) command. Each [PHASE](#) in a stack can apply an independent IOUT\_CAL\_OFFSET value. The effective IOUT\_CAL\_OFFSET value for a stack is equal to the sum of the IOUT\_CAL\_OFFSET values from all devices in the stack.

图 6-38. (39h) IOUT\_CAL\_OFFSET Register Map

15	14	13	12	11	10	9	8
RW	RW	RW	RW	RW	RW	RW	RW
IOCOS_EXP					IOCOS_MAN		
7	6	5	4	3	2	1	0
RW	RW	RW	RW	RW	RW	RW	RW
IOCOS_MAN							

LEGEND: R/W = Read/Write; R = Read only

表 6-49. Register Field Descriptions

Bit	Field	Access	Reset	Description
15:11	IOCOS_EXP	RW	11100b	Linear format, two's complement exponent
10:0	IOCOS_MAN	RW	NVM	Linear format, two's complement mantissa

Attempts to write [\(39h\) IOUT\\_CAL\\_OFFSET](#) to any value outside those specified as valid are considered invalid or unsupported data and cause the TPSM8D6C24 to respond by flagging the appropriate status bits and notifying the host according to the PMBus 1.3.1 Part II specification section 10.9.3.

#### Command Resolution and NVM Store or Restore Behavior

The [\(39h\) IOUT\\_CAL\\_OFFSET](#) command is implemented using the TPSM8D6C24 internal telemetry system. As a result, the value of this command can be programmed with very high resolution using the linear format. However, the TPSM8D6C24 only provides limited NVM-backed options for this command. Following a power-cycle or NVM Store and Restore operation, the value is restored to one of the supported values, according to the value present during the last NVM store operation. During operation, updates to this command with higher resolution are supported, and accepted as long as they fall between the minimum and maximum supported values given.

#### Phased Command Behavior

PHASE = 00h to 03h: Writes to [\(39h\) IOUT\\_CAL\\_OFFSET](#) modify the current sense offset for individual phases. Reads to [\(39h\) IOUT\\_CAL\\_OFFSET](#) return the configured current sense offset for individual phases.

PHASE = FFh: Writes to [\(39h\) IOUT\\_CAL\\_OFFSET](#) modify the total current sense offset for all individual phases. Individual phases are assigned an IOUT\_CAL\_OFFSET value equal to the written value divided by the number of phases. Reads to [\(39h\) IOUT\\_CAL\\_OFFSET](#) return the configured current sense offset for PHASE = 00h times the number of phases.

### 6.6.33 (40h) VOUT\_OV\_FAULT\_LIMIT

CMD Address	40h
Write Transaction:	Write Word
Read Transaction:	Read Word
Format:	ULINEAR16 Relative or Absolute per <a href="#">VOUT_MODE</a>
Phased:	No
NVM Backup:	EEPROM
Updates:	On-the-fly

The [VOUT\\_OV\\_FAULT\\_LIMIT](#) command sets the value of the output voltage measured at the sense or output pins that causes an output overvoltage fault. [VOUT\\_OV\\_FAULT\\_LIMIT](#) sets an overvoltage threshold relative to the current [VOUT\\_COMMAND](#). Updates to [VOUT\\_COMMAND](#) do not update the value of [VOUT\\_OV\\_FAULT\\_LIMIT](#) when the absolute format is used. Note that even with [VOUT\\_MODE](#) configured in absolute format, the true overvoltage fault limit remains relative to the current [VOUT\\_COMMAND](#). [VOUT\\_OV\\_FAULT\\_LIMIT](#) is active as soon as the TPSM8D6C24 completes its power-on reset, even if output conversion is disabled.

Following an overvoltage fault condition, the TPSM8D6C24 responds according to [VOUT\\_OV\\_FAULT\\_RESPONSE](#).

图 6-39. (40h) VOUT\_OV\_FAULT\_LIMIT Register Map

15	14	13	12	11	10	9	8
RW	RW	RW	RW	RW	RW	RW	RW
VOUT_OVF (High Byte)							
7	6	5	4	3	2	1	0
RW	RW	RW	RW	RW	RW	RW	RW
VOUT_OVF (Low Byte)							

LEGEND: R/W = Read/Write; R = Read only

表 6-50. Register Field Descriptions

Bit	Field	Access	Reset	Description
15:0	VOUT_OVF	RW	See Below	Sets the overvoltage fault limit. Format is per <a href="#">VOUT_MODE</a> .

### Hardware Support and Value Mapping

The hardware for [VOUT\\_OV\\_FAULT\\_LIMIT](#) is implemented as a fixed percentage of the current output voltage target. Depending on the [VOUT\\_MODE](#) setting, the value written to [VOUT\\_OV\\_FAULT\\_LIMIT](#) must be mapped to the hardware percentage.

Programmed values not exactly equal to one of the hardware relative values are rounded up to the next available relative value supported by hardware. The hardware supports values from 105% to 140% of [VOUT\\_COMMAND](#) in 2.5% steps. When output conversion is disabled, the hardware supports values from 110% to 140% of [VOUT\\_COMMAND](#) in 10% steps.

Attempts to write [VOUT\\_OV\\_FAULT\\_LIMIT](#) to any value outside those specified as valid are considered invalid or unsupported data and cause the TPSM8D6C24 to respond by flagging the appropriate status bits and notifying the host according to the PMBus 1.3.1 Part II specification section 10.9.3.

### 6.6.34 (41h) VOUT\_OV\_FAULT\_RESPONSE

CMD Address	41h
Write Transaction:	Write Byte
Read Transaction:	Read Byte
Format:	Unsigned Binary (1 byte)
Phased:	No
NVM Backup:	EEPROM
Updates:	On-the-fly

The **VOUT\_OV\_FAULT\_RESPONSE** command instructs the device on what action to take in response to an output overvoltage fault. Upon triggering the overvoltage fault, the TPSM8D6C24 controller responds according to the following data byte, and the following actions are taken:

- Set the VOUT\_OV\_FAULT bit in the **STATUS\_BYTE**.
- Set the VOUT bit in the **STATUS\_WORD**.
- Set the VOUT\_OVF bit in the **STATUS\_VOUT** register.
- Notify the host per PMBus 1.3.1 Part II specification, section 10.2.

**图 6-40. (41h) VOUT\_OV\_FAULT\_RESPONSE Register Map**

7	6	5	4	3	2	1	0
RW	RW	RW	RW	RW	RW	RW	RW
VO_OV_RESP		VO_OV_RETRY			VO_OV_DELAY		

LEGEND: R/W = Read/Write; R = Read only

**表 6-51. Register Field Descriptions**

Bit	Field	Access	Reset	Description
7:6	VO_OV_RESP	RW	NVM	Output overvoltage response 00b: Ignore. Continue operating without interruption. 01b: Shut down. Shut down and retry according to VO_OV_RETRY. 10b: Shut down. Shut down and retry according to VO_OV_RETRY. 11b: Invalid or unsupported
5:3	VO_OV_RETRY	RW	NVM	0d: Do not attempt to restart (latch off). 1d - 6d: After shutting down, wait one HICCUP period, and attempt to restart up to one to six times. After one to six failed restart attempts, do not attempt to restart (latch off). 7d: After shutting down, wait one HICCUP period, and attempt to restart indefinitely, until commanded OFF, or a successful start-up occurs.
2:0	VO_OV_DELAY	RW	NVM	0d: VO_OV HICCUP period is equal to TON_RISE. 1d - 7d: VO_OV HICCUP period is equal to one to seven times TON_RISE.

Attempts to write **VOUT\_OV\_FAULT\_RESPONSE** to any value outside those specified as valid are considered invalid or unsupported data and cause the TPSM8D6C24 to respond by flagging the appropriate status bits and notifying the host according to the PMBus 1.3.1 Part II specification section 10.9.3.

A restart attempt is successful and the restart limit counter is reset to 0 when no fault with a shutdown response is observed after one (61h) **TON\_RISE** time after completing (61h) **TON\_RISE** or after (62h) **TON\_MAX\_FAULT\_LIMIT** if (62h) **TON\_MAX\_FAULT\_LIMIT** is not set to 0 ms (Disabled).

If (41h) **VOUT\_OV\_FAULT\_RESPONSE** is configured to ignore a VOUT\_OV\_FAULT, and a VOUT\_OV\_FAULT is present at the time of enabling the device, the device does not start up. To ensure the part ignores any potential VOUT\_OV\_FAULT at start-up, set the (40h) **VOUT\_OV\_FAULT\_LIMIT** greater than the maximum possible input voltage applied during start-up.

### 6.6.35 (42h) VOUT\_OV\_WARN\_LIMIT

CMD Address	42h
Write Transaction:	Write Word
Read Transaction:	Read Word
Format:	ULINEAR16 Relative or Absolute per <a href="#">VOUT_MODE</a>
Phased:	No
NVM Backup:	EEPROM
Updates:	On-the-fly

The [VOUT\\_OV\\_WARN\\_LIMIT](#) command sets the value of the output voltage at the sense or output pins that causes an output voltage high warning. This value is typically less than the output overvoltage threshold. The [OV\\_WARN\\_LIMIT](#) sets an overvoltage threshold relative to the current [VOUT\\_COMMAND](#). Updates to [VOUT\\_COMMAND](#) do not update the value of [VOUT\\_OV\\_FAULT\\_LIMIT](#) when the absolute format is used.

When the sensed output voltage exceeds the [VOUT\\_OV\\_WARN\\_LIMIT](#) threshold, the following actions are taken:

- Set the VOUT bit in the [STATUS\\_WORD](#).
- Set the VOUT\_OVW bit in the [STATUS\\_VOUT](#) register.
- Notify the host per PMBus 1.3.1 Part II specification, section 10.2.

图 6-41. (42h) VOUT\_OV\_WARN\_LIMIT Register Map

15	14	13	12	11	10	9	8
RW	RW	RW	RW	RW	RW	RW	RW
VOUT_OVW (High Byte)							
7	6	5	4	3	2	1	0
RW	RW	RW	RW	RW	RW	RW	RW
VOUT_OVW (Low Byte)							

LEGEND: R/W = Read/Write; R = Read only

表 6-52. Register Field Descriptions

Bit	Field	Access	Reset	Description
15:0	VOUT_OVW	RW	NVM	Sets the overvoltage warning limit. Format is per <a href="#">VOUT_MODE</a> .

### Hardware Support and Value Mapping

The hardware for [VOUT\\_OV\\_WARN\\_LIMIT](#) is implemented as a fixed percentage of the current output voltage target. Depending on the [VOUT\\_MODE](#) setting, the value written to [VOUT\\_OV\\_WARN\\_LIMIT](#) must be mapped to a hardware percentage.

Programmed values not exactly equal to one of the hardware relative values shall be rounded up to the next available relative value supported by hardware. The hardware supports values from 103% to 116% [VOUT\\_COMMAND](#) in 1% steps.

Attempts to write [\(42h\) VOUT\\_OV\\_WARN\\_LIMIT](#) to any value outside those specified as valid are considered invalid or unsupported data and cause the TPSM8D6C24 to respond by flagging the appropriate status bits and notifying the host according to the PMBus 1.3.1 Part II specification section 10.9.3.

### 6.6.36 (43h) VOUT\_UV\_WARN\_LIMIT

CMD Address	43h
Write Transaction:	Write Word
Read Transaction:	Read Word
Format:	ULINEAR16 Relative or Absolute per <a href="#">VOUT_MODE</a>
Phased:	No
NVM Backup:	EEPROM
Updates:	On-the-fly

The [VOUT\\_UV\\_WARN\\_LIMIT](#) command sets the value of the output voltage at the sense or output pins that causes an output voltage low warning. The [VOUT\\_UV\\_WARN\\_LIMIT](#) sets an undervoltage threshold relative to the current [VOUT\\_COMMAND](#). Updates to [VOUT\\_COMMAND](#) do not update [VOUT\\_UV\\_WARN\\_LIMIT](#) when the absolute format is used.

When the sensed output voltage exceeds the [VOUT\\_UV\\_WARN\\_LIMIT](#) threshold, the following actions are taken:

- Set the VOUT bit in the [STATUS\\_WORD](#).
- Set the VOUT\_UVW bit in the [STATUS\\_VOUT](#) register.
- Notify the host per PMBus 1.3.1 Part II specification, section 10.2.

图 6-42. (43h) VOUT\_UV\_WARN\_LIMIT Register Map

15	14	13	12	11	10	9	8
RW	RW	RW	RW	RW	RW	RW	RW
VOUT_UVW (High Byte)							
7	6	5	4	3	2	1	0
RW	RW	RW	RW	RW	RW	RW	RW
VOUT_UVW (Low Byte)							

LEGEND: R/W = Read/Write; R = Read only

表 6-53. Register Field Descriptions

Bit	Field	Access	Reset	Description
15:0	VOUT_UVW	RW	NVM	Sets the undervoltage warning limit. Format is per <a href="#">VOUT_MODE</a> .

### Hardware Mapping and Supported Values

The hardware for [VOUT\\_UV\\_WARN\\_LIMIT](#) is implemented as a fixed percentage relative to the current output voltage target. Depending on the [VOUT\\_MODE](#) setting, the value written to [VOUT\\_UV\\_WARN\\_LIMIT](#) must be mapped to the hardware percentage.

Programmed values not exactly equal to one of the hardware relative values is rounded down to the next available relative value supported by hardware. The hardware supports values from 84% to 97% [VOUT\\_COMMAND](#) in 1% steps.

Attempts to write (43h) [VOUT\\_UV\\_WARN\\_LIMIT](#) to any value outside those specified as valid are considered invalid or unsupported data and cause the TPSM8D6C24 to respond by flagging the appropriate status bits and notifying the host according to the PMBus 1.3.1 Part II specification section 10.9.3.

### 6.6.37 (44h) VOUT\_UV\_FAULT\_LIMIT

CMD Address	44h
Write Transaction:	Write Word
Read Transaction:	Read Word
Format:	ULINEAR16 Absolute per <a href="#">VOUT_MODE</a>
Phased:	No
NVM Backup:	EEPROM
Updates:	On-the-fly

The [VOUT\\_UV\\_FAULT\\_LIMIT](#) command sets the value of the output voltage at the sense or output pins that causes an output voltage fault. The [VOUT\\_UV\\_FAULT\\_LIMIT](#) sets an undervoltage threshold relative to the current [VOUT\\_COMMAND](#). Updates to [VOUT\\_COMMAND](#) do not update [VOUT\\_UV\\_FAULT\\_LIMIT](#) when the absolute format is used.

When the undervoltage fault condition is triggered, the TPSM8D6C24 responds according to [VOUT\\_UV\\_FAULT\\_RESPONSE](#).

图 6-43. (44h) VOUT\_UV\_FAULT\_LIMIT Register Map

15	14	13	12	11	10	9	8
RW	RW	RW	RW	RW	RW	RW	RW
VOUT_UVF (High Byte)							
7	6	5	4	3	2	1	0
RW	RW	RW	RW	RW	RW	RW	RW
VOUT_UVF (Low Byte)							

LEGEND: R/W = Read/Write; R = Read only

表 6-54. Register Field Descriptions

Bit	Field	Access	Reset	Description
15:0	VOUT_UVW	RW	NVM	Sets the undervoltage fault limit. Format is per <a href="#">VOUT_MODE</a> .

### Hardware Mapping and Supported Values

The hardware for [VOUT\\_UV\\_FAULT\\_LIMIT](#) is implemented as a fixed percentage relative to the current output voltage target. Depending on the [VOUT\\_MODE](#) setting, the value written to [VOUT\\_UV\\_FAULT\\_LIMIT](#) must be mapped to the hardware percentage.

Programmed values not exactly equal to one of the hardware relative values are rounded down to the next available relative value supported by hardware. The hardware supports values from 60% to 95% of [VOUT\\_COMMAND](#) in 2.5% steps.

Attempts to write (44h) [VOUT\\_UV\\_FAULT\\_LIMIT](#) to any value outside those specified as valid are considered invalid or unsupported data and cause the TPSM8D6C24 to respond by flagging the appropriate status bits and notifying the host according to the PMBus 1.3.1 Part II specification section 10.9.3.



### 6.6.38 (45h) VOUT\_UV\_FAULT\_RESPONSE

CMD Address	45h
Write Transaction:	Write Byte
Read Transaction:	Read Byte
Format:	Unsigned Binary (1 byte)
Phased:	No
NVM Backup:	EEPROM
Updates:	On-the-fly

The **VOUT\_UV\_FAULT\_RESPONSE** command instructs the device on what action to take in response to an output undervoltage fault. Upon triggering the overvoltage fault, the TPSM8D6C24 responds according to the following data byte, and the following actions are taken:

- Set the NONE OF THE ABOVE bit in the **STATUS\_BYTE**.
- Set the VOUT bit in the **STATUS\_WORD**.
- Set the VOUT\_UVF bit in the **STATUS\_VOUT** register.
- Notify the host per PMBus 1.3.1 Part II specification, section 10.2.

**图 6-44. (45h) VOUT\_UV\_FAULT\_RESPONSE Register Map**

7	6	5	4	3	2	1	0
RW	RW	RW	RW	RW	RW	RW	RW
VO_UV_RESP		VO_UV_RETRY			VO_UV_DLY		

LEGEND: R/W = Read/Write; R = Read only

**表 6-55. Register Field Descriptions**

Bit	Field	Access	Reset	Description
7:6	VO_UV_RESP	RW	NVM	Output undervoltage response 00b: Ignore. Continue operating without interruption. 01b: Shutdown after delay, as set by VO_UV_DLY 10b: Shutdown Immediately Other: Invalid or unsupported
5:3	VO_UV_RETRY	RW	NVM	Output undervoltage retry 0d: Do not attempt to restart (latch off). 1d-6d: After shutting down, wait one HICCUP period, and attempt to restart up to one to six times. After one to six failed restart attempts, do not attempt to restart (latch off). 7d: After shutting down, wait one HICCUP period, and attempt to restart indefinitely, until commanded OFF, or a successful start-up occurs.
2:0	VO_UV_DLY	RW	NVM	Output undervoltage delay time for respond after delay and HICCUP 0d: Shutdown delay of one PWM_CLK, HICCUP equal to TON_RISE 1d: Shutdown delay of one PWM_CLK, HICCUP equal to TON_RISE 2d - 4d: Shutdown delay of three PWM_CLK, HICCUP equal to two to six times TON_RISE 5d - 7d: Shutdown delay of seven PWM_CLK, HICCUP equal to five to seven times TON_RISE

Attempts to write **(45h) VOUT\_UV\_FAULT\_RESPONSE** to any value outside those specified as valid are considered invalid or unsupported data and cause the TPSM8D6C24 to respond by flagging the appropriate status bits and notifying the host according to the PMBus 1.3.1 Part II specification section 10.9.3.

### 6.6.39 (46h) IOUT\_OC\_FAULT\_LIMIT

CMD Address	46h
Write Transaction:	Write Word
Read Transaction:	Read Word
Format:	SLINEAR11 per <a href="#">CAPABILITY</a>
Phased:	Yes
NVM Backup:	EEPROM or Pin Detection
Updates:	On-the-fly

The [IOUT\\_OC\\_FAULT\\_LIMIT](#) command sets the value of the output current that causes the overcurrent detector to indicate an overcurrent fault condition. While each TPSM8D6C24 device in a multi-phase stack has its own IOUT\_OC\_FAULT\_LIMIT and comparator, the effective current limit of the multi-phase stack is equal to the lowest IOUT\_OC\_FAULT\_LIMIT setting times the number of phases in the stack.

When the overcurrent fault is triggered, the TPSM8D6C24 responds according to [IOUT\\_OC\\_FAULT\\_RESPONSE](#).

图 6-45. (46h) IOUT\_OC\_FAULT\_LIMIT Register Map

15	14	13	12	11	10	9	8
RW	RW	RW	RW	RW	RW	RW	RW
IO_OCF_EXP					IO_OCF_MAN		
7	6	5	4	3	2	1	0
RW	RW	RW	RW	RW	RW	RW	RW
IO_OCF_MAN							

LEGEND: R/W = Read/Write; R = Read only

表 6-56. Register Field Descriptions

Bit	Field	Access	Reset	Description
15:11	IO_OCF_EXP	RW	11110b	Linear format two's complement exponent
10:0	IO_OCF_MAN	RW	NVM	Linear format two's complement mantissa. Refer to the following table. Multi-phase Stack Current Limit up to 62 A × Number of Phases (PHASE = FFh) Per Phase OCL: up to 62 A (PHASE != FFh)

Attempts to write [\(46h\) IOUT\\_OC\\_FAULT\\_LIMIT](#) to any value outside those specified as valid are considered invalid or unsupported data and cause the TPSM8D6C24 to respond by flagging the appropriate status bits and notifying the host according to the PMBus 1.3.1 Part II specification section 10.9.3.

#### Command Resolution and NVM Store or Restore Behavior

The Per-PHASE (PHASE != FFh) [IOUT\\_OC\\_FAULT\\_LIMIT](#) is implemented in analog hardware. The analog hardware supports current limits from 8 A to 62 A in 2-A steps. Programmed values not exactly equal to hardware supported values are rounded up to the next available supported value. Values less than 8 A per device can be written to IOUT\_OC\_FAULT\_LIMIT, but values less than 8 A per device are implemented as 8 A in hardware. The TPSM8D6C24 provides only limited NVM-backed options for this command. Following a power cycle or NVM Store or Restore operation, the value is rounded to the nearest NVM supported value. The NVM supports values up to 62 A in 0.25-A steps.

#### Phased Command Behavior

Write when PHASE = FFh: Set IOUT\_OC\_FAULT\_LIMIT for each phase to the written value divided by the number of phases.

Read when PHASE = FFh: Report the IOUT\_OC\_FAULT\_LIMIT value of PHASE = 00h (loop controller) times the number of phases.

Write when PHASE != FFh: Set IOUT\_OC\_FAULT\_LIMIT for the current phase to the written value.

Read when PHASE != FFh: Report the IOUT\_OC\_FAULT\_LIMIT value of the current phase.

### 6.6.40 (47h) IOUT\_OC\_FAULT\_RESPONSE

CMD Address	47h
Write Transaction:	Write Byte
Read Transaction:	Read Byte
Format:	Unsigned Binary (1 byte)
Phased:	No
NVM Backup:	EEPROM
Updates:	On-the-fly

The [IOUT\\_OC\\_FAULT\\_RESPONSE](#) command instructs the device on what action to take in response to an overcurrent fault. Upon triggering the overcurrent fault, the TPSM8D6C24 responds according to the following data byte, and the following actions are taken:

- Set the IOUT\_OC bit in the [STATUS\\_BYTE](#).
- Set the IOUT bit in the [STATUS\\_WORD](#).
- Set the IOUT\_OCF bit in the [STATUS\\_IOUT](#) register.
- Notify the host per PMBus 1.3.1 Part II specification, section 10.2.

图 6-46. (47h) IOUT\_OC\_FAULT\_RESPONSE Register Map

7	6	5	4	3	2	1	0
RW	RW	RW	RW	RW	R	R	R
IO_OC_RESP		IO_OC_RETRY			IO_OC_DELAY		

LEGEND: R/W = Read/Write; R = Read only

表 6-57. Register Field Descriptions

Bit	Field	Access	Reset	Description
7:6	IO_OC_RESP	RW	NVM	Output overcurrent response 00b: Ignore. Continue operating without interruption. 01b: Ignore. Continue operating without interruption. 10b: Shut down after delay as set by IO_OC_DELAY 11b: Shutdown immediately
5:3	IO_OC_RETRY	RW	NVM	Output overcurrent retry 0d: Do not attempt to restart (latch off). 1d - 6d: After shutting down, wait one HICCUP period, and attempt to restart up to one to six times. After one to six failed restart attempts, do not attempt to restart (latch off). 7d: After shutting down, wait one HICCUP period, and attempt to restart indefinitely until commanded OFF, or a successful start-up occurs.
2:0	IO_OC_DELAY	RW	NVM	Output overcurrent delay time for respond after delay and HICCUP 0d: Shutdown delay of one PWM_CLK, HICCUP equal to TON_RISE 1d: Shutdown delay of one PWM_CLK, HICCUP equal to TON_RISE 2d - 4d: Shutdown delay of three PWM_CLK, HICCUP equal to two to four times TON_RISE 5d - 7d: Shutdown delay of seven PWM_CLK, HICCUP equal to five to seven times TON_RISE

Attempts to write [\(47h\) IOUT\\_OC\\_FAULT\\_RESPONSE](#) to any value outside those specified as valid are considered invalid or unsupported data and cause the TPSM8D6C24 to respond by flagging the appropriate status bits and notifying the host according to the PMBus 1.3.1 Part II specification section 10.9.3.

### 6.6.41 (4Ah) IOUT\_OC\_WARN\_LIMIT

CMD Address	4Ah
Write Transaction:	Write Word
Read Transaction:	Read Word
Format:	SLINEAR11 per <a href="#">CAPABILITY</a>
Phased:	Yes
NVM Backup:	EEPROM or Pin Detection
Updates:	On-the-fly

The [IOUT\\_OC\\_WARN\\_LIMIT](#) command sets the value of the output current that causes the overcurrent detector to indicate an overcurrent warning condition. The units are amperes.

IOUT\_OC\_WARN\_LIMIT is a phased command. Each phase reports an output current overcurrent warning independently.

In response to an overcurrent warning condition, the TPSM8D6C24 takes the following action:

- Set the NONE OF THE ABOVE bit in the [STATUS\\_BYTE](#).
- Set the IOUT bit in the [STATUS\\_WORD](#).
- Set the IOUT\_OCW bit in the [STATUS\\_IOUT](#) register.
- Notify the host per PMBus 1.3.1 Part II specification, section 10.2.

图 6-47. (4Ah) IOUT\_OC\_WARN\_LIMIT Register Map

15	14	13	12	11	10	9	8
RW	RW	RW	RW	RW	RW	RW	RW
IOOCW_EXP				IOOCW_MAN			
7	6	5	4	3	2	1	0
RW	RW	RW	RW	RW	RW	RW	RW
IOOCW_MAN							

LEGEND: R/W = Read/Write; R = Read only

表 6-58. Register Field Descriptions

Bit	Field	Access	Reset	Description
15:11	IOOCW_EXP	RW	11110b	Linear format two's complement exponent
10:0	IOOCW_MAN	RW	NVM	Linear format two's complement mantissa Supported values up to 62 A times the number of phases.

Attempts to write [\(4Ah\) IOUT\\_OC\\_WARN\\_LIMIT](#) to any value outside those specified as valid are considered invalid or unsupported data and cause the TPSM8D6C24 to respond by flagging the appropriate status bits and notifying the host according to the PMBus 1.3.1 Part II specification section 10.9.3.

#### Command Resolution and NVM Store or Restore Behavior

The Per-PHASE (PHASE != FFh) [IOUT\\_OC\\_WARN\\_LIMIT](#) is implemented in analog hardware. The analog hardware supports current limits from 8 A to 62 A in 2-A steps. Programmed values not exactly equal to hardware supported values are rounded up to the next available supported value. Values less than 8 A per device can be written to IOUT\_OC\_FAULT\_LIMIT, but values less than 8 A per device are implemented as 8 A in hardware. The TPSM8D6C24 provides only limited NVM-backed options for this command. Following a power-cycle or NVM Store or Restore operation, the value is rounded to the nearest NVM supported value. The NVM supports values up to 62 A in 0.25-A steps.

### 6.6.42 (4Fh) OT\_FAULT\_LIMIT

CMD Address	4Fh
Write Transaction:	Write Word
Read Transaction:	Read Word
Format:	SLINEAR11 per <a href="#">CAPABILITY</a>
Phased:	Yes
NVM Backup:	EEPROM
Updates:	On-the-fly

The [OT\\_FAULT\\_LIMIT](#) command sets the value of the temperature limit, in degrees Celsius, that causes an overtemperature fault condition.

The converter response to an overtemperature event is described in [OT\\_FAULT\\_RESPONSE](#).

**图 6-48. (4Fh) OT\_FAULT\_LIMIT Register Map**

15	14	13	12	11	10	9	8
RW	RW	RW	RW	RW	RW	RW	RW
OTF_EXP				OTF_MAN			
7	6	5	4	3	2	1	0
RW	RW	RW	RW	RW	RW	RW	RW
OTF_MAN							

LEGEND: R/W = Read/Write; R = Read only

**表 6-59. Register Field Descriptions**

Bit	Field	Access	Reset	Description
15:11	OTF_EXP	RW	00000b	Linear format two' s complement exponent
10:0	OTF_MAN	RW	NVM	Linear format two' s complement mantissa. Refer to the following text.

Attempts to write [\(4Fh\) OT\\_FAULT\\_LIMIT](#) to any value outside those specified as valid are considered invalid or unsupported data and cause the TPSM8D6C24 to respond by flagging the appropriate status bits and notifying the host according to the PMBus 1.3.1 Part II specification section 10.9.3.

#### Command Resolution and NVM Store or Restore Behavior

The [\(4Fh\) OT\\_FAULT\\_LIMIT](#) command is implemented using the TPSM8D6C24 internal telemetry system. As a result, the value of this command can be programmed with very high resolution using the linear format. However, the TPSM8D6C24 provides only limited NVM-backed options for this command. Following a power-cycle or NVM Store or Restore operation, the value is restored to the nearest NVM supported value. The NVM supports values from 0°C to 160°C in 1°C steps. Programming a value of 255°C disables the programmable overtemperature fault limit without disabling the on-die bandgap thermal shutdown.

### 6.6.43 (50h) OT\_FAULT\_RESPONSE

CMD Address	50h
Write Transaction:	Write Byte
Read Transaction:	Read Byte
Format:	Unsigned Binary (1 byte)
Phased:	No
NVM Backup:	EEPROM
Updates:	On-the-fly

The **OT\_FAULT\_RESPONSE** command instructs the device on what action to take in response to an overtemperature fault. Upon triggering the overtemperature fault, the converter responds per the following data byte, and the following actions are taken:

- Set the TEMP bit in the **STATUS\_BYTE**.
- Set the OTF bit in the **STATUS\_TEMPERATURE** register.
- Notify the host per PMBus 1.3.1 Part II specification, section 10.2.

The OT Fault hysteresis is set by the **(51h) OT\_WARN\_LIMIT**. When **(8Dh) READ\_TEMPERATURE\_1** falls below **(51h) OT\_WARN\_LIMIT**, the overtemperature fault condition is released and restart is allowed if selected by **(50h) OT\_FAULT\_RESPONSE**. If **(51h) OT\_WARN\_LIMIT** is programmed higher than **(4Fh) OT\_FAULT\_LIMIT**, a default hysteresis of 20°C is used instead.

**图 6-49. (50h) OT\_FAULT\_RESPONSE Register Map**

7	6	5	4	3	2	1	0
RW	RW	RW	RW	RW	RW	RW	RW
OTF_RESP		OT_RETRY			OT_DELAY		

LEGEND: R/W = Read/Write; R = Read only

**表 6-60. Register Field Descriptions**

Bit	Field	Access	Reset	Description
7:6	OTF_RESP	RW	NVM	Overtemperature fault response 00b: Ignore. Continue operating without interruption. 01b: Delayed shutdown continue operating for 10 ms × OT_DELAY. If OT_FAULT is still present, shut down and restart according to OT_RETRY. 10b: Immediate Shutdown. Shut down and restart according to OT_RETRY. 11b: Shut down until temperature is below OT_WARN_LIMIT, then restart according to OT_RETRY*.
5:3	OT_RETRY	RW	NVM	Overtemperature retry 0d: Do not attempt to restart (latch off). 1d-6d: After shutting down, wait one HICCUP period, and attempt to restart up to one to six times. After one to six failed restart attempts, do not attempt to restart (latch off). Restart attempts that occur while temperature is above OT_WARN_LIMIT are not observable but are counted. 7d: After shutting down, wait one HICCUP period, and attempt to restart indefinitely, until commanded OFF or a successful start-up occurs.
2:0	OT_DELAY	RW	NVM	Overtemperature delay time for respond after delay and HICCUP 0d: Shutdown delay of 10 ms, HICCUP equal to TON_RISE, HICCUP delay equal to TON_RISE 1d - 7d: Shutdown delay of 1 to 7 ms, HICCUP equal to two to four times TON_RISE

Attempts to write **(50h) OT\_FAULT\_RESPONSE** to any value outside those specified as valid are considered invalid or unsupported data and cause the TPSM8D6C24 to respond by flagging the appropriate status bits and notifying the host according to the PMBus 1.3.1 Part II specification section 10.9.3.

\*When (50h) [OT\\_FAULT\\_RESPONSE](#) OTF\_RESP (Bits 7:6) are set to 11b, shut down until temperature is below (51h) [OT\\_WARN\\_LIMIT](#), issuing a (03h) [CLEAR\\_FAULTS](#) command while the temperature is between (4Fh) [OT\\_FAULT\\_LIMIT](#) and (51h) [OT\\_WARN\\_LIMIT](#) can result in the TPSM8D6C24 remaining in the OT FAULT state until the temperature rises above (4Fh) [OT\\_FAULT\\_LIMIT](#) or disabled and enabled according to (02h) [ON\\_OFF\\_CONFIG](#).

If (50h) [OT\\_FAULT\\_RESPONSE](#) is configured to ignore a OT\_FAULT, and a OT\_FAULT is present at the time of enabling the device, the device does not start up. To ensure the part ignores any potential OT\_FAULT at start-up, it is recommended to set the (4Fh) [OT\\_FAULT\\_LIMIT](#) greater than the maximum possible temperature during start-up.



### 6.6.44 (51h) OT\_WARN\_LIMIT

CMD Address	51h
Write Transaction:	Write Word
Read Transaction:	Read Word
Format:	SLINEAR11 per <a href="#">CAPABILITY</a>
Phased:	Yes
NVM Backup:	EEPROM
Updates:	On-the-fly

The [OT\\_WARN\\_LIMIT](#) command sets the temperature, in degrees Celsius, of the unit, at which, it indicates an overtemperature warning alarm. The units are degrees C.

Upon triggering the overtemperature fault, the converter responds per the following data byte, and the following actions are taken:

- Set the TEMP bit in the [STATUS\\_BYTE](#).
- Set the OTW bit in the [STATUS\\_TEMPERATURE](#) register.
- Notify the host per PMBus 1.3.1 Part II specification, section 10.2.

图 6-50. (51h) OT\_WARN\_LIMIT Register Map

15	14	13	12	11	10	9	8
RW	RW	RW	RW	RW	RW	RW	RW
OTW_EXP				OTW_MAN			
7	6	5	4	3	2	1	0
RW	RW	RW	RW	RW	RW	RW	RW
OTW_MAN							

LEGEND: R/W = Read/Write; R = Read only

表 6-61. Register Field Descriptions

Bit	Field	Access	Reset	Description
15:11	OTW_EXP	RW	00000b	Linear format two' s complement exponent
10:0	OTW_MAN	RW	NVM	Linear format two' s complement mantissa. Refer to the following text.

Attempts to write [\(51h\) OT\\_WARN\\_LIMIT](#) to any value outside those specified as valid are considered invalid or unsupported data and cause the TPSM8D6C24 to respond by flagging the appropriate status bits and notifying the host according to the PMBus 1.3.1 Part II specification section 10.9.3.

#### Command Resolution and NVM Store or Restore Behavior

The [\(51h\) OT\\_WARN\\_LIMIT](#) command is implemented using the TPSM8D6C24 internal telemetry system. As a result, the value of this command can be programmed with very high resolution using the linear format. However, the TPSM8D6C24 provides only limited NVM-backed options for this command. Following a power-cycle or NVM Store or Restore operation, the value is restored to the nearest NVM supported value. The NVM supports values from 0°C to 160°C in 1°C steps. Programming OT\_WARN\_LIMIT to a value of 255°C disables the OT\_WARN\_LIMIT function.

OT\_WARN\_LIMIT is used to provide hysteresis to OT\_FAULT\_LIMIT faults. If OT\_WARN\_LIMIT is programmed greater than OT\_FAULT\_LIMIT, including disabling OT\_WARN\_LIMIT with a value of 255°C, a default hysteresis of 20°C is used instead.

### 6.6.45 (55h) VIN\_OV\_FAULT\_LIMIT

CMD Address	55h
Write Transaction:	Write Word
Read Transaction:	Read Word
Format:	SLINEAR11 per <a href="#">CAPABILITY</a>
Phased:	No
NVM Backup:	EEPROM
Updates:	On-the-fly

The (55h) [VIN\\_OV\\_FAULT\\_LIMIT](#) command sets the PVIN voltage, in volts, when a VIN\_OV\_FAULT is declared. The response to a detected VIN\_OV\_FAULT is determined by the settings of (56h) [VIN\\_OV\\_FAULT\\_RESPONSE](#). (55h) [VIN\\_OV\\_FAULT\\_LIMIT](#) is typically used to stop switching in the event of excessive input voltage, which can result in over-stress damage to the power FETs due to ringing on the SW node.

图 6-51. (55h) VIN\_OV\_FAULT\_LIMIT Register Map

15	14	13	12	11	10	9	8
RW	RW	RW	RW	RW	RW	RW	RW
VINOVF_EXP					VINOVF_MAN		
7	6	5	4	3	2	1	0
RW	RW	RW	RW	RW	RW	RW	RW
VINOVF_MAN							

LEGEND: R/W = Read/Write; R = Read only

表 6-62. Register Field Descriptions

Bit	Field	Access	Reset	Description
15:11	VINOVF_EXP	RW	11110b	Linear format two's complement exponent
10:0	VINOVF_MAN	RW	NVM	Linear format two's complement mantissa

Attempts to write (55h) [VIN\\_OV\\_FAULT\\_LIMIT](#) beyond the supported range are considered invalid or unsupported data and cause the TPSM8D6C24 to respond by flagging the appropriate status bits and notifying the host according to the PMBus 1.3.1 Part II specification section 10.9.3. (55h) [VIN\\_OV\\_FAULT\\_LIMIT](#) supports values from 4 V to 20 V in 0.25-V steps. Following a power cycle or STORE/RESTORE, (55h) [VIN\\_OV\\_FAULT\\_LIMIT](#) is restored to the nearest supported value.

### 6.6.46 (56h) VIN\_OV\_FAULT\_RESPONSE

CMD Address	56h
Write Transaction:	Write Byte
Read Transaction:	Read Byte
Format:	Unsigned Binary (1 byte)
Phased:	No
NVM Backup:	EEPROM
Updates:	On-the-fly

The VIN\_OV\_FAULT\_RESPONSE command instructs the device on what action to take in response to a PVIN overvoltage fault. Upon triggering the PVIN overvoltage fault, the converter responds per the following data byte, and the following actions are taken:

- Set the NONE OF THE ABOVE bit in the [STATUS\\_BYTE](#) register.
- Set the INPUT bit in the upper byte of the STATUS\_WORD register.
- Set the VIN\_OV bit in the STATUS\_INPUT register.
- Notify the host per PMBus 1.3.1 Part II specification, section 10.2.

图 6-52. (56h) VIN\_OV\_FAULT\_RESPONSE Register Map

7	6	5	4	3	2	1	0
RW	RW	RW	RW	RW	RW	RW	RW
VINOVF_RESP		VINOVF_RETRY			VINOVF_DLY		

LEGEND: R/W = Read/Write; R = Read only

表 6-63. Register Field Descriptions

Bit	Field	Access	Reset	Description
7:6	VIN_OVF_RESP	RW	NVM	PVIN overvoltage fault response 00b: Ignore. Continue operating without interruption. 01b: Delayed shutdown continue operating for a number of switching cycles defined by VIN_OVF_DLY, then if fault persists, shut down and restart according to VIN_OV_RETRY. 10b: Immediate shutdown. Shut down and restart according to VIN_OV_RETRY. 11b: Invalid or not supported
5:3	VIN_OVF_RETRY	RW	NVM	PVIN overvoltage retry 0d: Do not attempt to restart (latch off). 1d - 6d: After shutting down, wait one HICCUP period, and attempt to restart up to one to six times. After one to six failed restart attempts, do not attempt to restart (latch off). Restart attempts that occur while PVIN voltage is above VIN_OV_FAULT_LIMIT is not observable but is counted. 7d: After shutting down, wait one HICCUP period, and attempt to restart indefinitely, until commanded OFF, or a successful start-up occurs.
2:0	VIN_OVF_DLY	RW	NVM	PVIN overvoltage delay time for respond after delay and HICCUP 0d: Shutdown delay of one PWM_CLK, HICCUP equal to TON_RISE 1d: Shutdown delay of one PWM_CLK, HICCUP equal to TON_RISE 2d - 4d: Shutdown delay of three PWM_CLK, HICCUP equal to two to four times TON_RISE 5d - 7d: Shutdown delay of seven PWM_CLK, HICCUP equal to five to seven times TON_RISE

If (56h) VIN\_OV\_FAULT\_RESPONSE is configured to ignore a VIN\_OV\_FAULT and a VIN\_OV\_FAULT is present at the time of enabling the device, the device does not start up. To ensure the part ignores any potential VIN\_OV\_FAULT at start-up, set the (55h) VIN\_OV\_FAULT\_LIMIT greater than the maximum possible input voltage applied during start-up.

Attempts to write (56h) [VIN\\_OV\\_FAULT\\_RESPONSE](#) to any value outside those specified as valid are considered invalid or unsupported data and cause the TPSM8D6C24 to respond by flagging the appropriate status bits and notifying the host according to the PMBus 1.3.1 Part II specification section 10.9.3.

### 6.6.47 (58h) VIN\_UV\_WARN\_LIMIT

CMD Address	58h
Write Transaction:	Write Word
Read Transaction:	Read Word
Format:	SLINEAR11 per <a href="#">CAPABILITY</a>
Phased:	Yes
NVM Backup:	EEPROM
Updates:	On-the-fly

The (58h) [VIN\\_UV\\_WARN\\_LIMIT](#) command sets the value of the PVIN pin voltage, in volts, that causes the input voltage detector to indicate an input undervoltage warning.

The (58h) [VIN\\_UV\\_WARN\\_LIMIT](#) is a phase command, each phase within a stack independently detects and reports input undervoltage warnings.

In response to an input undervoltage warning condition, the TPSM8D6C24 takes the following action:

- Set the NONE OF THE ABOVE bit in the [STATUS\\_BYTE](#).
- Set the INPUT bit in the [STATUS\\_WORD](#).
- Set the VIN\_UVW bit in the [STATUS\\_INPUT](#) register.
- Notify the host per PMBus 1.3.1 Part II specification, section 10.2.

**图 6-53. (58h) VIN\_UV\_WARN\_LIMIT Register Map**

15	14	13	12	11	10	9	8
RW	RW	RW	RW	RW	RW	RW	RW
VINUVW_EXP				VINUVW_MAN			
7	6	5	4	3	2	1	0
RW	RW	RW	RW	RW	RW	RW	RW
VINUVW_MAN							

LEGEND: R/W = Read/Write; R = Read only

**表 6-64. Register Field Descriptions**

Bit	Field	Access	Reset	Description
15:11	VINUVW_EXP	RW	11110b	Linear format two's complement exponent
10:0	VINUVW_MAN	RW	NVM	Linear format two's complement mantissa Supported values 2.5 V to 15.5 V

Attempts to write (58h) [VIN\\_UV\\_WARN\\_LIMIT](#) to any value outside those specified as valid are considered invalid or unsupported data and cause the TPSM8D6C24 to respond by flagging the appropriate status bits and notifying the host according to the PMBus 1.3.1 Part II specification section 10.9.3.

### 6.6.48 (60h) TON\_DELAY

CMD Address	60h
Write Transaction:	Write Word
Read Transaction:	Read Word
Format:	SLINEAR11 per <a href="#">CAPABILITY</a>
Phased:	No
NVM Backup:	EEPROM
Updates:	On-the-fly

The [TON\\_DELAY](#) command sets the time, in milliseconds, from when a start condition is received (as programmed by the [ON\\_OFF\\_CONFIG](#) command) until the output voltage starts to rise.

图 6-54. (60h) TON\_DELAY Register Map

15	14	13	12	11	10	9	8
RW	RW	RW	RW	RW	RW	RW	RW
TONDLY_EXP					TONDLY_MAN		
7	6	5	4	3	2	1	0
RW	RW	RW	RW	RW	RW	RW	RW
TONDLY_MAN							

LEGEND: R/W = Read/Write; R = Read only

表 6-65. Register Field Descriptions

Bit	Field	Access	Reset	Description
15:11	TONDLY_EXP	RW	11111b	Linear format two' s complement exponent.
10:0	TONDLY_MAN	RW	NVM	Linear format two' s complement mantissa. A minimum turn-on delay of approximately 100 $\mu$ s is observed even when TON_DELAY, during which, the device initializes itself at every power-on.

Attempts to write [\(60h\) TON\\_DELAY](#) beyond the supported range are considered invalid or unsupported data and cause the TPSM8D6C24 to respond by flagging the appropriate status bits and notifying the host according to the PMBus 1.3.1 Part II specification section 10.9.3. TON\_DELAY supports values from 0 ms to 127.5 ms in 0.5-ms steps. Following a power cycle or STORE/RESTORE, TON\_DELAY is restored to the nearest supported value.

Refer to the [Start-Up and Shutdown](#) behavior section for handling of corner cases with respect to interrupted [TON\\_DELAY](#), [TON\\_RISE](#), [TOFF\\_FALL](#), and [TOFF\\_DELAY](#) times.

### 6.6.49 (61h) TON\_RISE

CMD Address	61h
Write Transaction:	Write Word
Read Transaction:	Read Word
Format:	SLINEAR11 per <a href="#">CAPABILITY</a>
Phased:	No
NVM Backup:	EEPROM or Pin Detection
Updates:	On-the-fly

The [TON\\_RISE](#) command sets the time, in milliseconds, from when the output starts to rise until the voltage has entered the regulation band, which effectively sets the slew rate of the reference DAC during the soft-start period. Note that the rise time is equal to [TON\\_RISE](#) regardless of the value of the target output voltage or [VOUT\\_SCALE\\_LOOP](#).

Due to hardware limitations in the resolution of the reference DAC slew-rate control, longer [TON\\_RISE](#) times with higher [VOUT\\_COMMAND](#) voltages can result in some quantization error in the programmed [TON\\_RISE](#) times with several [TON\\_RISE](#) times producing the same [VOUT](#) slope and [TON\\_RISE](#) time even with different [TON\\_RISE](#) settings or different [TON\\_RISE](#) times for the same [TON\\_RISE](#) setting and different [VOUT\\_COMMAND](#) voltages.

**图 6-55. (61h) TON\_RISE Register Map**

15	14	13	12	11	10	9	8
RW	RW	RW	RW	RW	RW	RW	RW
TONR_EXP				TONR_MAN			
7	6	5	4	3	2	1	0
RW	RW	RW	RW	RW	RW	RW	RW
TONR_MAN							

LEGEND: R/W = Read/Write; R = Read only

**表 6-66. Register Field Descriptions**

Bit	Field	Access	Reset	Description
15:11	TONR_EXP	RW	11110b	Linear format two' s complement exponent
10:0	TONR_MAN	RW	NVM	Linear format two' s complement mantissa

Attempts to write [\(61h\) TON\\_RISE](#) beyond the supported range are considered invalid or unsupported data and cause the [TPSM8D6C24](#) to respond by flagging the appropriate status bits and notifying the host according to the PMBus 1.3.1 Part II specification section 10.9.3. [TON\\_RISE](#) supports the range from 0 ms to 31.75 ms in 0.25-ms steps. Values less than 0.5 ms are supported as 0.5 ms.

### 6.6.50 (62h) TON\_MAX\_FAULT\_LIMIT

CMD Address	62h
Write Transaction:	Write Word
Read Transaction:	Read Word
Format:	SLINEAR11 per <a href="#">CAPABILITY</a>
Phased:	No
NVM Backup:	EEPROM
Updates:	On-the-fly

The [TON\\_MAX\\_FAULT\\_LIMIT](#) command sets an upper limit, in milliseconds, on how long the unit can attempt to power up the output without reaching the target voltage.

The TON\_MAX time is defined as the maximum allowable amount of time from the end of [TON\\_DELAY](#), until the output voltage reaches 85% of the programmed output voltage, as sensed by the READ\_VOUT telemetry at VOSNS – GOSNS.

The TPSM8D6C24 undervoltage fault limit is enabled at the end of TON\_RISE. As a consequence, unless [VOUT\\_UV\\_FAULT\\_RESPONSE](#) is set to ignore, in the case of a “real” TON\_MAX fault (for example, output voltage did not rise quickly enough), UV faults and the associated response always precede TON\_MAX.

The converter response to a TON\_MAX fault event is described in [TON\\_MAX\\_FAULT\\_RESPONSE](#).

**图 6-56. (62h) TON\_MAX\_FAULT\_LIMIT Register Map**

15	14	13	12	11	10	9	8
RW	RW	RW	RW	RW	RW	RW	RW
TONMAXF_EXP				TONMAXF_MAN			
7	6	5	4	3	2	1	0
RW	RW	RW	RW	RW	RW	RW	RW
TONMAXF_MAN							

LEGEND: R/W = Read/Write; R = Read only

**表 6-67. Register Field Descriptions**

Bit	Field	Access	Reset	Description
15:11	TONMAXF_EXP	RW	11111b	Linear format two' s complement exponent
10:0	TONMAXF_MAN	RW	NVM	Linear format two' s complement mantissa

Attempts to write [\(62h\) TON\\_MAX\\_FAULT\\_LIMIT](#) are considered an invalid or unsupported command and cause the TPSM8D6C24 to respond by flagging the appropriate status bits and notifying the host according to the PMBus 1.3.1 Part II specification section 10.9.3. TON\_MAX\_FAULT\_LIMIT supports values from 0 ms to 127 ms in 0.5-ms steps.

\*Note: programming TON\_MAX\_FAULT to 0 ms disables the TON\_MAX functionality.



### 6.6.51 (63h) TON\_MAX\_FAULT\_RESPONSE

CMD Address	63h
Write Transaction:	Write Byte
Read Transaction:	Read Byte
Format:	Unsigned Binary (1 byte)
Phased:	No
NVM Backup:	EEPROM
Updates:	On-the-fly

The [TON\\_MAX\\_FAULT\\_RESPONSE](#) command instructs the device on what action to take in response to TON\_MAX fault. Upon triggering the input TON\_MAX fault, the converter responds per the following byte and the following actions are taken:

- Set the NONE OF THE ABOVE bit in the [STATUS\\_BYTE](#).
- Set the VOUT bit in the [STATUS\\_WORD](#).
- Set the TON\_MAX bit in [STATUS\\_VOUT](#).
- Notify the host per PMBus 1.3.1 Part II specification, section 10.2.

图 6-57. (63h) TON\_MAX\_FAULT\_RESPONSE Register Map

7	6	5	4	3	2	1	0
RW	RW	RW	RW	RW	RW	RW	RW
TONMAX_RESP		TONMAX_RETRY			TONMAX_DELAY		

LEGEND: R/W = Read/Write; R = Read only

表 6-68. Register Field Descriptions

Bit	Field	Access	Reset	Description
7:6	TONMAX_RESP	RW	NVM	TON_MAX fault response 00b: Ignore. Continue operating without interruption. 01b: Continue operating for the delay time specified by TONMAX_DELAY. If the fault is still present, shut down and restart according to TONMAX_RETRY. 10b: Shut down immediately and restart according to TONMAX_RETRY. Other: Invalid or unsupported
5:3	TONMAX_RETRY	RW	NVM	TON_MAX fault retry 0d: Do not attempt to restart (latch off). 1d - 6d: After shutting down, wait one HICCUP period, and attempt to restart up to one to six times. 7d: After shutting down, wait one HICCUP period, and attempt to restart indefinitely, until commanded OFF, or a successful start-up occurs.
2:0	TONMAX_DELAY	RW	NVM	TON_MAX delay time for respond after delay and HICCUP 0d: Shutdown delay of 1 ms, HICCUP equal to TON_RISE 1d - 7d: Shutdown delay of 1 to 7 ms. HICCUP equal to two to seven times TON_RISE.

Attempts to write (63h) [TON\\_MAX\\_FAULT\\_RESPONSE](#) to any value outside those specified as valid are considered invalid or unsupported data and cause the TPSM8D6C24 to respond by flagging the appropriate status bits and notifying the host according to the PMBus 1.3.1 Part II specification section 10.9.3.

### 6.6.52 (64h) TOFF\_DELAY

CMD Address	64h
Write Transaction:	Write Word
Read Transaction:	Read Word
Format:	SLINEAR11 per <a href="#">CAPABILITY</a>
Phased:	No
NVM Backup:	EEPROM
Updates:	On-the-fly

The [TOFF\\_DELAY](#) command sets the time, in milliseconds, from when a stop condition is received (as programmed by the [ON\\_OFF\\_CONFIG](#) command) until the unit stops transferring energy to the output.

**图 6-58. (64h) TOFF\_DELAY Register Map**

15	14	13	12	11	10	9	8
RW	RW	RW	RW	RW	RW	RW	RW
TOFFDLY_EXP					TOFFDLY_MAN		
7	6	5	4	3	2	1	0
RW	RW	RW	RW	RW	RW	RW	RW
TOFFDLY_MAN							

LEGEND: R/W = Read/Write; R = Read only

**表 6-69. Register Field Descriptions**

Bit	Field	Access	Reset	Description
15:11	TOFFDLY_EXP	RW	11111b	Linear format two' s complement exponent
10:0	TOFFDLY_MAN	RW	NVM	Linear format two' s complement mantissa

Attempts to write [\(64h\) TOFF\\_DELAY](#) beyond the supported range are considered invalid or unsupported data and cause the TPSM8D6C24 to respond by flagging the appropriate status bits and notifying the host according to the PMBus 1.3.1 Part II specification section 10.9.3. TOFF\_DELAY supports values from 0 ms to 127.5 ms in 0.5-ms steps. An internal delay of up to 50  $\mu$ s is added to TOFF\_DELAY, even if TOFF\_DELAY is equal to 0 ms.

### 6.6.53 (65h) TOFF\_FALL

CMD Address	65h
Write Transaction:	Write Word
Read Transaction:	Read Word
Format:	SLINEAR11 per <a href="#">CAPABILITY</a>
Phased:	No
NVM Backup:	EEPROM
Updates:	On-the-fly

The [TOFF\\_FALL](#) command sets the time, in milliseconds, from the end of the turn-off delay time until the voltage is commanded to 0. This command can only be used with a device whose output can sink enough current to cause the output voltage to decrease at a controlled rate, which effectively sets the slew rate of the reference DAC during the soft-off period. The fall time is equal to [TOFF\\_FALL](#) regardless of the value of the target output voltage or [VOUT\\_SCALE\\_LOOP](#) for the purposes of slew rate selection based on the target output voltage.

**图 6-59. (65h) TOFF\_FALL Register Map**

15	14	13	12	11	10	9	8
RW	RW	RW	RW	RW	RW	RW	RW
TOFFF_EXP					TOFFF_MAN		
7	6	5	4	3	2	1	0
RW	RW	RW	RW	RW	RW	RW	RW
TOFFF_MAN							

LEGEND: R/W = Read/Write; R = Read only

**表 6-70. Register Field Descriptions**

Bit	Field	Access	Reset	Description
15:11	TOFFF_EXP	RW	11110b	Linear format two' s complement exponent. Exponent = -2, LSB = 0.25 ms
10:0	TOFFF_MAN	RW	NVM	Linear format two' s complement mantissa

Attempts to write [\(65h\) TOFF\\_FALL](#) beyond the supported range are considered invalid or unsupported data and cause the TPSM8D6C24 to respond by flagging the appropriate status bits and notifying the host according to the PMBus 1.3.1 Part II specification section 10.9.3. [\(65h\) TOFF\\_FALL](#) supports values from 0.5 ms to 31.75 ms in 0.25-ms steps. Values less than 0.5 ms are implemented as 0.5 ms.

Due to hardware limitations in the resolution of the reference DAC slew-rate control, longer [TOFF\\_FALL](#) times with higher [\(21h\) VOUT\\_COMMAND](#) voltages can result in some quantization error in the programmed [TOFF\\_FALL](#) times with several [TOFF\\_FALL](#) times producing the same VOUT slope and [TOFF\\_FALL](#) time even with different [TOFF\\_FALL](#) settings, or different [TOFF\\_FALL](#) times for the same [TOFF\\_FALL](#) setting and different [\(21h\) VOUT\\_COMMAND](#) voltages.

### 6.6.54 (78h) STATUS\_BYTE

CMD Address	78h
Write Transaction:	Write Byte
Read Transaction:	Read Byte
Format:	Unsigned Binary (1 byte)
Phased:	Yes
NVM Back-up:	No
Updates:	On-the-fly

The **STATUS\_BYTE** command returns one byte of information with a summary of the most critical faults, such as overvoltage, overcurrent, overtemperature, and so forth. The supported **STATUS\_BYTE** message content is described in the following table. The **STATUS\_BYTE** is equal the low byte of **STATUS\_WORD**. The conditions in the **STATUS\_BYTE** are summary information only. They are asserted to inform the host as to which other STATUS registers should be checked in the event of a fault. Setting and clearing of these bits must be done in the individual status registers. For example, Clearing VOUT\_OVF in **STATUS\_VOUT** also clears VOUT\_OV in **STATUS\_BYTE**.

图 6-60. (78h) STATUS\_BYTE Register Map

7	6	5	4	3	2	1	0
RW	R	R	R	R	R	R	R
BUSY	OFF	VOUT_OV	IOUT_OC	VIN_UV	TEMP	CML	NONE OF THE ABOVE

LEGEND: R/W = Read/Write; R = Read only

表 6-71. Register Field Descriptions

Bit	Field	Access	Reset	Description
7	BUSY	RW	0b	0b: A fault was NOT declared because the device was busy and unable to respond. 1b: A fault was declared because the device was busy and unable to respond.
6	OFF	R	0b	LIVE (unlatched) status bit 0b: The unit is enabled and converting power. 1b: The unit is NOT converting power for any reason including simply not being enabled.
5	VOUT_OV	R	0b	0b: An output overvoltage fault has NOT occurred. 1b: An output overvoltage fault has occurred.
4	IOUT_OC	R	0b	0b: An output overcurrent fault has NOT occurred. 1b: An output overcurrent fault has occurred.
3	VIN_UV	R	0b	0b: An input undervoltage fault has NOT occurred. 1b: An input undervoltage fault has occurred.
2	TEMP	R	0b	0b: A temperature fault/warning has NOT occurred. 1b: A temperature fault/warning has occurred, the host should check STATUS_TEMPERATURE for more information.
1	CML	R	0b	0b: A communication, memory, logic fault has NOT occurred. 1b: A communication, memory, logic fault has occurred, the host should check STATUS_CML for more information.
0	NONE OF THE ABOVE	R	0b	0b: A fault other than those listed above has NOT occurred. 1b: A fault other than those listed above has occurred. The host should check the STATUS_WORD for more information.

Writing 80h to STATUS\_BYTE will clear the BUSY bit, if set.

### 6.6.55 (79h) STATUS\_WORD

CMD Address	79h
Write Transaction:	Write Word
Read Transaction:	Read Word
Format:	Unsigned Binary (2 bytes)
Phased:	Yes
NVM Backup:	No
Updates:	On-the-fly

The **STATUS\_WORD** command returns two bytes of information with a summary of the most critical faults, such as overvoltage, overcurrent, overtemperature, and so forth. The low byte of the **STATUS\_WORD** is the same register as the **STATUS\_BYTE**. The supported **STATUS\_WORD** message content is described in the following table. The conditions in the **STATUS\_BYTE** are summary information only.

**图 6-61. (79h) STATUS\_WORD Register Map**

15	14	13	12	11	10	9	8
R	R	R	R	R	R	R	R
VOUT	IOUT	INPUT	MFR	PGOOD	0	OTHER	0
7	6	5	4	3	2	1	0
RW	R	R	R	R	R	R	R
STATUS_BYTE							

LEGEND: R/W = Read/Write; R = Read only

**表 6-72. Register Field Descriptions**

Bit	Field	Access	Reset	Description
15	VOUT	R	0b	0b: An output voltage related fault has <i>not</i> occurred. 1b: An output voltage fault has occurred. The host must check STATUS_ VOUT for more information.
14	IOUT	R	0b	0b: An output current related fault has <i>not</i> occurred. 1b: An output current fault has occurred. The host must check STATUS_ IOUT for more information.
13	INPUT	R	0b	0b: An input related fault has <i>not</i> occurred. 1b: An input fault has occurred. The host must check STATUS_ INPUT for more information.
12	MFR	R	0b	0b: A manufacturer-defined fault has <i>not</i> occurred. 1b: A manufacturer-defined fault has occurred. The host must check STATUS_ MFR_ SPECIFIC for more information.
11	PGOOD	R	0b	LIVE (unlatched) status bit. Always follows the value of the PGOOD/RESET_B pin is asserted. 0b: The output voltage is within the regulation window. The PGOOD pin is de-asserted. 1b: The output voltage is <i>not</i> within the regulation window. The PGOOD pin is asserted.
10	Not Supported	R	0b	Not supported and always set to 0b.
9	OTHER	R	0b	0b: An OTHER fault has not occurred. 1b: An OTHER fault has occurred, the host must check STATUS_ OTHER for more information.
8	Not Supported	R	0b	Not supported and always set to 0b.
7:0	STATUS_ BYTE	RW	00h	Always equal to the STATUS_ BYTE value.

All bits that can trigger SMBALERT have a corresponding bit in [SMBALERT\\_MASK](#).

Writing 0080h to STATUS\_WORD clears the BUSY bit, if set. Writing 0180h to STATUS\_WORD clears both the BUSY bit and UNKNOWN bit, if set.

### 6.6.56 (7Ah) STATUS\_VOUT

CMD Address	7Ah
Write Transaction:	Write Byte
Read Transaction:	Read Byte
Format:	Unsigned Binary (1 byte)
Phased:	No
NVM Backup:	No
Updates:	On-the-fly

The **STATUS\_VOUT** command returns one data byte with contents as follows. All supported bits can be cleared either by **CLEAR\_FAULTS**, or individually by writing 1b to the (7Ah) **STATUS\_VOUT** register in their position, per the PMBus 1.3.1 Part II specification section 10.2.4.

图 6-62. (7Ah) STATUS\_VOUT Register Map

7	6	5	4	3	2	1	0
RW	RW	RW	RW	RW	RW	R	R
VOUT_OVF	VOUT_OVW	VOUT_UVW	VOUT_UVF	VOUT_MIN_MAX	TON_MAX	0	0

LEGEND: R/W = Read/Write; R = Read only

表 6-73. Register Field Descriptions

Bit	Field	Access	Reset	Description
7	VOUT_OVF	RW	0b	0b: Latched flag indicating VOUT OV fault has <i>not</i> occurred. 1b: Latched flag indicating a VOUT OV fault has occurred. Note: the mask bits for VOUT_OVF masks fixed, tracking, and prebiased OVP. These can be individually controlled in SMBALERT_MASK_EXTENDED.
6	VOUT_OVW	RW	0b	0b: Latched flag indicating a VOUT OV warn has <i>not</i> occurred. 1b: Latched flag indicating a VOUT OV warn has occurred. Note: the mask bits for VOUT_OVF masks fixed and tracking overvoltage protection.
5	VOUT_UVW	RW	0b	0b: Latched flag indicating VOUT UV warn has <i>not</i> occurred. 1b: Latched flag indicating a VOUT UV warn has occurred.
4	VOUT_UVF	RW	0b	0b: Latched flag indicating VOUT UV fault has <i>not</i> occurred. 1b: Latched flag indicating a VOUT UV fault has occurred.
3	VOUT_MIN_MAX	RW	0b	0b: Latched flag indicating a VOUT_MIN_MAX has <i>not</i> occurred. 1b: Latched flag indicating a VOUT_MIN_MAX has occurred.
2	TON_MAX	RW	0b	0b: Latched flag indicating a TON_MAX has <i>not</i> occurred. 1b: Latched flag indicating a TON_MAX has occurred.
1:0	Not supported	R	00b	Not supported and always set to 00b.

All bits that can trigger SMBALERT have a corresponding bit in **SMBALERT\_MASK**.

### 6.6.57 (7Bh) STATUS\_IOUT

CMD Address	7Bh
Write Transaction:	Write Byte
Read Transaction:	Read Byte
Format:	Unsigned Binary (1 byte)
Phased:	Yes
NVM Backup:	No
Updates:	On-the-fly

The [STATUS\\_IOUT](#) command returns one data byte with contents as follows. All supported bits can be cleared either by [CLEAR\\_FAULTS](#), or individually by writing 1b to the (7Bh) [STATUS\\_IOUT](#) register in their position, per the PMBus 1.3.1 Part II specification section 10.2.4.

图 6-63. (7Bh) STATUS\_IOUT Register Map

7	6	5	4	3	2	1	0
RW	R	RW	RW	R	R	R	R
IOUT_OCF	0	IOUT_OCW	0	0	0	0	0

LEGEND: R/W = Read/Write; R = Read only

表 6-74. Register Field Descriptions

Bit	Field	Access	Reset	Description
7	IOUT_OCF	RW	0b	0b: Latched flag indicating IOUT OC fault has <i>not</i> occurred. 1b: Latched flag indicating an IOUT OC fault has occurred.
6	Not Supported	R	0b	Not supported and always set to 0b.
5	IOUT_OCW	RW	0b	0b: Latched flag indicating IOUT OC warn has <i>not</i> occurred. 1b: Latched flag indicating an IOUT OC warn has occurred.
4:0	Not supported	R	0b	Not supported and always set to 00000b

All bits that can trigger SMBALERT have a corresponding bit in [SMBALERT\\_MASK](#).



### 6.6.58 (7Ch) STATUS\_INPUT

CMD Address	7Ch
Write Transaction:	Write Byte
Read Transaction:	Read Byte
Format:	Unsigned Binary (1 byte)
Phased:	Yes
NVM Backup:	No
Updates:	On-the-fly

The [STATUS\\_INPUT](#) command returns one data byte with contents as follows. All supported bits can be cleared either by [CLEAR\\_FAULTS](#), or individually by writing 1b to the (7Ch) [STATUS\\_INPUT](#) register in their position, per the PMBus 1.3.1 Part II specification section 10.2.4.

**图 6-64. (7Ch) STATUS\_INPUT Register Map**

7	6	5	4	3	2	1	0
RW	R	RW	R	RW	R	R	R
VIN_OVF	0	VIN_UVW	0	LOW_VIN	0	0	0

LEGEND: R/W = Read/Write; R = Read only

**表 6-75. Register Field Descriptions**

Bit	Field	Access	Reset	Description
7	VIN_OVF	RW	0b	0b: Latched flag indicating PVIN OV fault has <i>not</i> occurred. 1b: Latched flag indicating PVIN OV fault has occurred.
6	VIN_OVW	RW	0b	Not supported and always set to 0b.
5	VIN_UVW		0b	0b: Latched flag indicating PVIN UV warn occurred. 1b: Latched flag indicating PVIN UV warn has occurred.
4	Not Supported	R	0b	Not supported and always set to 0b.
3	LOW_VIN	RW	0b	LIVE (unlatched) status bit. Showing the value of PVIN relative to VIN_ON and VIN_OFF. 0b: PVIN is ON. 1b: PVIN is OFF.
2:0	Not Supported	R	000b	Not supported and always set to 000b.

All bits that can trigger SMBALERT have a corresponding bit in [SMBALERT\\_MASK](#).

#### LOW\_VIN Versus VIN\_UVW

The LOW\_VIN bit is an information only (does not assert SMBALERT) flag, which indicates that the device is not converting power because its PVIN voltage is less than [VIN\\_ON](#) or the VDD5 voltage is less than its UVLO to enable conversion. LOW\_VIN asserts initially at reset but does not assert SMBALERT.

The VIN\_UVW bit is a latched status bit, may assert SMBALERT if it is triggered to alert the host of an input voltage issue. VIN\_UVW IS masked until the first time the sensed input voltage exceeds the [VIN\\_ON](#) threshold.

### 6.6.59 (7Dh) STATUS\_TEMPERATURE

CMD Address	7Dh
Write Transaction:	Write Byte
Read Transaction:	Read Byte
Format:	Unsigned Binary (1 byte)
Phased:	Yes
NVM Backup:	No
Updates:	On-the-fly

The [STATUS\\_TEMPERATURE](#) command returns one data byte with contents as follows. All supported bits can be cleared either by [CLEAR\\_FAULTS](#), or individually by writing 1b to the (7Dh) [STATUS\\_TEMPERATURE](#) register in their position, per the PMBus 1.3.1 Part II specification section 10.2.4.

图 6-65. (7Dh) STATUS\_TEMPERATURE Register Map

7	6	5	4	3	2	1	0
RW	RW	R	R	R	R	R	R
OTF	OTW	0	0	0	0	0	0

LEGEND: R/W = Read/Write; R = Read only

表 6-76. Register Field Descriptions

Bit	Field	Access	Reset	Description
7	OTF	RW	0b	0b: Latched flag indicating an OT fault has <i>not</i> occurred. 1b: Latched flag indicating an OT fault has occurred.
6	OTW	RW	0b	0b: Latched flag indicating an OT warn has <i>not</i> occurred. 1b: Latched flag indicating an OT warn has occurred.
5:0	Not supported	R	0d	Not supported and always set to 000000b.

All bits that can trigger SMBALERT have a corresponding bit in [SMBALERT\\_MASK](#).

### 6.6.60 (7Eh) STATUS\_CML

CMD Address	7Eh
Write Transaction:	Write Byte
Read Transaction:	Read Byte
Format:	Unsigned Binary (1 byte)
Phased:	Yes
NVM Backup:	No
Updates:	On-the-fly

The [STATUS\\_CML](#) command returns one data byte with contents relating to communications, logic, and memory as follows. All supported bits can be cleared either by [CLEAR\\_FAULTS](#), or individually by writing 1b to the (7Eh) [STATUS\\_CML](#) register in their position, per the PMBus 1.3.1 Part II specification section 10.2.4.

图 6-66. (7Eh) STATUS\_CML Register Map

7	6	5	4	3	2	1	0
RW	RW	RW	RW	RW	R	RW	R
IVC	IVD	PEC	MEM	PROC_FLT	0	COMM	0

LEGEND: R/W = Read/Write; R = Read only

表 6-77. Register Field Descriptions

Bit	Field	Access	Reset	Description
7	IVC	RW	0b	0b: Latched flag indicating invalid or unsupported command was <i>not</i> received. 1b: Latched flag indicating an invalid or unsupported command was received.
6	IVD	RW	0b	0b: Latched flag indicating invalid or unsupported data was <i>not</i> received. 1b: Latched flag indicating an invalid or unsupported data was received.
5	PEC	RW	0b	0b: Latched flag indicating <i>no</i> packet error check has failed. 1b: Latched flag indicating a packet error check has failed.
4	MEM	RW	0b	0b: Latched flag indicating <i>no</i> memory error was detected. 1b: Latched flag indicating a memory error was detected.
3	PROC_FLT	RW	0b	0b: Latched flag indicating <i>no</i> logic core error was detected. 1b: Latched flag indicating a logic core error was detected.
2	Not supported	R	0b	Not supported and always set to 0b.
1	COMM	RW	0b	0b: Latched flag indicating <i>no</i> communication error detected. 1b: Latched flag indicating communication error detected.
0	Not supported	R	0b	Not supported and always set to 0b.

All bits that can trigger SMBALERT have a corresponding bit in [SMBALERT\\_MASK](#).

Loop followers report a back-channel communications issue as a CML fault on their phase.

The corresponding bit [STATUS\\_BYTE](#) is an OR'ing of the supported bits in this command. When a fault condition in this command occurs, the corresponding bit in [STATUS\\_BYTE](#) is updated. Likewise, if this byte is individually cleared (for example, by a write of 1 to a latched condition), it clears the corresponding bit in [STATUS\\_BYTE](#).

### 6.6.61 (7Fh) STATUS\_OTHER

CMD Address	7Fh
Write Transaction:	Write Byte
Read Transaction:	Read Byte
Format:	Unsigned Binary (1 byte)
Phased:	No
NVM Backup:	No
Updates:	On-the-fly

The **STATUS\_OTHER** command returns one data byte with information not specified in the other STATUS bytes.

图 6-67. (7Fh) STATUS\_OTHER Register Map

7	6	5	4	3	2	1	0
R	R	R	R	R	R	R	RW
0	0	0	0	0	0	0	FIRST_TO_ALERT

LEGEND: R/W = Read/Write; R = Read only

表 6-78. Register Field Descriptions

Bit	Field	Access	Reset	Description
7:1	Reserved	R	0h	Reserved
0	FIRST_TO_ALERT	RW	0b	0b: Latched flag indicating that this device was <i>not</i> the first to assert SMBALERT, which can mean either that the SMBALERT signal is not asserted (or has since been cleared), or that it is asserted, but this device was not the first on the bus to assert it. 1b: Latched flag indicating that this device was the first to assert SMBALERT.

The corresponding bit **STATUS\_BYTE** is an OR'ing of the supported bits in this command. When a fault condition in this command occurs, the corresponding bit in **STATUS\_BYTE** is updated. Likewise, if this byte is individually cleared (for example, by a write of 1 to a latched condition), it should clear the corresponding bit in **STATUS\_BYTE**.

### 6.6.62 (80h) STATUS\_MFR\_SPECIFIC

CMD Address	80h
Write Transaction:	Write Byte
Read Transaction:	Read Byte
Format:	Unsigned Binary (1 byte)
Phased:	Yes
NVM Backup:	No
Updates:	On-the-fly

The [STATUS\\_MFR\\_SPECIFIC](#) command returns one data byte with contents regard of communications, logic, and memory as follows. All supported bits can be cleared either by [CLEAR\\_FAULTS](#), or individually by writing 1b to the (80h) [STATUS\\_MFR\\_SPECIFIC](#) register in their position, per the PMBus 1.3.1 Part II specification section 10.2.4.

图 6-68. (80h) STATUS\_MFR\_SPECIFIC Register Map

7	6	5	4	3	2	1	0
RW	R	R	R	RW	RW	RW	R
POR	SELF	0	0	RESET	BCX	SYNC	0

LEGEND: R/W = Read/Write; R = Read only

表 6-79. Register Field Descriptions

Bit	Field	Access	Reset	Description
7	POR	RW	0b	0: No power-on reset fault has been detected. 1: A power-on reset fault has been detected. This bit is set if: power-on self-check of internal trim values, USER_STORE NVM check-sum, or pin detection reports an invalid result.
6	SELF	R	0b	LIVE (unlatched) status bit. Showing the status of the power-on self-check. 0b: Power-on self-check is complete. All expected BCX loop followers have responded. 1b: Power-on self-check is in progress. One or more BCX loop followers have not responded.
5:4	Not supported	R	00b	Not supported and always set to 00b.
3	RESET	RW	0b:	0b: A RESET_VOUT event has <i>not</i> occurred. 1b: A RESET_VOUT event has occurred.
2	BCX	RW	0b	0b: A BCX fault event has <i>not</i> occurred. 1b: A BCX fault event has occurred.
1	SYNC	RW	0b	0b: No SYNC fault has been detected. 1b: A SYNC fault has been detected.
0	Not supported	R	0b	Not supported and always set to 0b.

Per the PMBus Spec writing a 1 to any bit in a STATUS register clears that bit if it is set. All bits that can trigger SMBALERT have a corresponding bit in [SMBALERT\\_MASK](#).

### 6.6.63 (88h) READ\_VIN

CMD Address	88h
Write Transaction:	N/A
Read Transaction:	Read Word
Format:	SLINEAR11 per <a href="#">CAPABILITY</a>
Phased:	Yes
NVM Backup:	No
Update Rate:	1 ms
Supported Range:	0 V – 24 V

The [READ\\_VIN](#) command returns the output current in amperes.

图 6-69. (88h) READ\_VIN Register Map

15	14	13	12	11	10	9	8
R	R	R	R	R	R	R	R
READ_VIN_EXP				READ_VIN_MAN			
7	6	5	4	3	2	1	0
R	R	R	R	R	R	R	R
READ_VIN_MAN							

LEGEND: R/W = Read/Write; R = Read only

表 6-80. Register Field Descriptions

Bit	Field	Access	Reset	Description
15:11	READ_VIN_EXP	RW	Input voltage	Linear format two' s complement exponent
10:0	READ_VIN_MAN	RW	Input voltage	Linear format two' s complement mantissa

Attempts to write read-only commands cause the CML: invalid command (IVC) fault condition, the TPSM8D6C24 responds as follows:

- Set the CML bit in [STATUS\\_BYTE](#).
- Set the CML\_IVC (bit 7) bit in [STATUS\\_CML](#).
- Notifying the host according to the PMBus 1.3.1 Part II specification section 10.9.3.

#### PHASE Behavior

When [PHASE](#) = FFh, [READ\\_VIN](#) returns the PVIN voltage of the loop controller device.

When [PHASE](#) != FFh, [READ\\_VIN](#) returns the PVIN voltage of the device assigned to the current [PHASE](#).

### 6.6.64 (8Bh) READ\_VOUT

CMD Address	8Bh
Write Transaction:	N/A
Read Transaction:	Read Word
Format:	ULINEAR16 per <a href="#">VOUT_MODE</a> .
Phased:	Yes
NVM Backup:	No
Update Rate:	1 ms
Supported Range	0 V to 6.0 V

The [READ\\_VOUT](#) command returns the actual, measured output voltage.

图 6-70. (8Bh) READ\_VOUT Register Map

15	14	13	12	11	10	9	8
R	R	R	R	R	R	R	R
READ_VOUT							
7	6	5	4	3	2	1	0
R	R	R	R	R	R	R	R
READ_VOUT							

LEGEND: R/W = Read/Write; R = Read only

表 6-81. Register Field Descriptions

Bit	Field	Access	Reset	Description
15:0	READ_VOUT	RW	Current Status	Output voltage reading, per <a href="#">VOUT_MODE</a>

READ\_VOUT reports the voltage at the VOSNS pin with respect to AGND when a device is configured as a loop follower (GOSNS = BP1V5). In this configuration, [VOUT\\_SCALE\\_LOOP](#) is ignored and VOSNS must be externally scaled to maintain a voltage between 0 V and 0.75 V for proper reporting of the VOSNS voltage.

Attempts to write read-only commands cause the CML: invalid command (IVC) fault condition, the TPSM8D6C24 responds as follows:

- Set the CML bit in [STATUS\\_BYTE](#).
- Set the CML\_IVC (bit 7) bit in [STATUS\\_CML](#).
- Notifying the host according to the PMBus 1.3.1 Part II specification section 10.9.3.

### 6.6.65 (8Ch) READ\_IOUT

CMD Address	8Ch
Write Transaction:	N/A
Read Transaction:	Read Word
Format:	SLINEAR11 per <a href="#">CAPABILITY</a>
Phased:	Yes
NVM Backup:	No
Update Rate:	1 ms
Supported Range:	– 15 A to 90 A per phase

The [READ\\_IOUT](#) command returns the output current in amperes.

图 6-71. (8Ch) READ\_IOUT Register Map

15	14	13	12	11	10	9	8
R	R	R	R	R	R	R	R
READ_IOUT_EXP				READ_IOUT_MAN			
7	6	5	4	3	2	1	0
R	R	R	R	R	R	R	R
READ_IOUT_MAN							

LEGEND: R/W = Read/Write; R = Read only

表 6-82. Register Field Descriptions

Bit	Field	Access	Reset	Description
15:11	READ_IOUT_EXP	RW	Current Status	Linear format two' s complement exponent
10:0	READ_IOUT_MAN	RW	Current Status	Linear format two' s complement mantissa

Attempts to write read-only commands cause the CML: invalid command (IVC) fault condition, the TPSM8D6C24 responds as follows:

- Set the CML bit in [STATUS\\_BYTE](#).
- Set the CML\_IVC (bit 7) bit in [STATUS\\_CML](#).
- Notifying the host according to the PMBus 1.3.1 Part II specification section 10.9.3.

#### PHASE Behavior

When [PHASE](#) = FFh, [READ\\_IOUT](#) returns the total current for the stack of devices supporting a single output.

When [PHASE](#) != FFh, [READ\\_IOUT](#) returns the measured current of the device assigned to the current [PHASE](#).



### 6.6.66 (8Dh) READ\_TEMPERATURE\_1

CMD Address	8Dh
Write Transaction:	N/A
Read Transaction:	Read Word
Format:	SLINEAR11 per <a href="#">CAPABILITY</a>
Phased:	Yes
NVM Backup:	No
Update Rate:	300 $\mu$ s
Supported Range:	- 40°C to 175°C

The [READ\\_TEMPERATURE\\_1](#) command returns the maximum power stage temperature in degrees Celsius.

**图 6-72. (8Dh) READ\_TEMPERATURE\_1 Register Map**

15	14	13	12	11	10	9	8
R	R	R	R	R	R	R	R
READ_T1_EXP				READ_T1_MAN			
7	6	5	4	3	2	1	0
R	R	R	R	R	R	R	R
READ_T1_MAN							

LEGEND: R/W = Read/Write; R = Read only

**表 6-83. Register Field Descriptions**

Bit	Field	Access	Reset	Description
15:11	READ_T1_EXP	RW	Current Status	Linear format two' s complement exponent. LSB = 1°C
10:0	READ_T1_MAN	RW	Current Status	Linear format two' s complement mantissa

Attempts to write read-only commands cause the CML: invalid command (IVC) fault condition, the TPSM8D6C24 responds as follows:

- Set the CML bit in [STATUS\\_BYTE](#).
- Set the CML\_IVC (bit 7) bit in [STATUS\\_CML](#).
- Notifying the host according to the PMBus 1.3.1 Part II specification section 10.9.3.

#### PHASE Behavior

When [PHASE](#) = FFh, [READ\\_TEMPERATURE\\_1](#) returns the temperature of the hottest of device in the stack of devices supporting a single output.

When [PHASE](#) != FFh, [READ\\_TEMPERATURE\\_1](#) returns the measured temperature of the device assigned to the current [PHASE](#).

### 6.6.67 (98h) PMBUS\_REVISION

CMD Address	98h
Write Transaction:	N/A
Read Transaction:	Read Byte
Format:	Unsigned Binary (1 byte)
Phased:	No
Max Transaction Time:	0.25 ms

The [PMBUS\\_REVISION](#) command reads the revision of the PMBus to which the device is compliant.

**图 6-73. (98h) PMBUS\_REVISION Register Map**

7	6	5	4	3	2	1	0
R	R	R	R	R	R	R	R
PART_I				PART_II			

LEGEND: R/W = Read/Write; R = Read only

**表 6-84. Register Field Descriptions**

Bit	Field	Access	Reset	Description
7:4	PART_I	R	0011b	0011b: Compliant to PMBus Rev 1.3, Part 1
3:0	PART_II	R	0011b	0011b: Compliant to PMBus Rev 1.3, Part 2

Attempts to write read-only commands cause the CML: invalid command (IVC) fault condition, the TPSM8D6C24 responds as follows:

- Set the CML bit in [STATUS\\_BYTE](#).
- Set the CML\_IVC (bit 7) bit in [STATUS\\_CML](#).
- Notifying the host according to the PMBus 1.3.1 Part II specification section 10.9.3.

### 6.6.68 (99h) MFR\_ID

CMD Address	99h
Write Transaction:	Write Block
Read Transaction:	Read Block
Format:	Unsigned Binary (3 bytes)
Phased:	No
NVM Backup:	EEPROM

The **MFR\_ID** command loads the unit with 3 bytes that contains the manufacturer's ID, which is typically done once at the time of manufacture.

**图 6-74. (99h) MFR\_ID Register Map**

23	22	21	20	19	18	17	16
RW	RW	RW	RW	RW	RW	RW	RW
MFR_ID							
15	14	13	12	11	10	9	8
RW	RW	RW	RW	RW	RW	RW	RW
MFR_ID							
7	6	5	4	3	2	1	0
RW	RW	RW	RW	RW	RW	RW	RW
MFR_ID							

LEGEND: R/W = Read/Write; R = Read only

**表 6-85. Register Field Descriptions**

Bit	Field	Access	Reset	Description
23:0	MFR_ID	RW	NVM	3 bytes of arbitrarily writable user-store NVM for manufacturer ID information.

### 6.6.69 (9Ah) MFR\_MODEL

CMD Address	9Ah
Write Transaction:	Write Block
Read Transaction:	Read Block
Format:	Unsigned Binary (3 bytes)
Phased:	No
NVM Backup:	EEPROM

The [MFR\\_MODEL](#) command loads the unit with 3 bytes that contains the manufacturer’s ID, which is typically done once at the time of manufacture.

图 6-75. (9Ah) MFR\_MODEL Register Map

23	22	21	20	19	18	17	16
RW	RW	RW	RW	RW	RW	RW	RW
MFR_MODEL							
15	14	13	12	11	10	9	8
RW	RW	RW	RW	RW	RW	RW	RW
MFR_MODEL							
7	6	5	4	3	2	1	0
RW	RW	RW	RW	RW	RW	RW	RW
MFR_MODEL							

LEGEND: R/W = Read/Write; R = Read only

表 6-86. Register Field Descriptions

Bit	Field	Access	Reset	Description
23:0	MFR_MODEL	RW	NVM	3 bytes of arbitrarily writable user-store NVM for manufacturer model information

### 6.6.70 (9Bh) MFR\_REVISION

CMD Address	9Bh
Write Transaction:	Write Block
Read Transaction:	Read Block
Format:	Unsigned Binary (3 bytes)
Phased:	No
NVM Backup:	EEPROM

The **MFR\_REVISION** command loads the unit with 3 bytes that contains the power supply manufacturer's revision number, which is typically done once at the time of manufacture.

**图 6-76. (9Bh) MFR\_REVISION Register Map**

23	22	21	20	19	18	17	16
RW	RW	RW	RW	RW	RW	RW	RW
MFR_REV							
15	14	13	12	11	10	9	8
RW	RW	RW	RW	RW	RW	RW	RW
MFR_REV							
7	6	5	4	3	2	1	0
RW	RW	RW	RW	RW	RW	RW	RW
MFR_REV							

LEGEND: R/W = Read/Write; R = Read only

**表 6-87. Register Field Descriptions**

Bit	Field	Access	Reset	Description
23:0	MFR_REV	RW	NVM	3 bytes of arbitrarily writable user-store NVM for manufacturer revision information

### 6.6.71 (9Eh) MFR\_SERIAL

CMD Address	9Eh
Write Transaction:	Write Block
Read Transaction:	Read Block
Format:	Unsigned Binary (3 bytes)
Phased:	No
NVM Backup:	EEPROM

The [MFR\\_SERIAL](#) command loads the unit with 3 bytes that contains the power supply manufacturer’s serial number, which is typically done once at the time of manufacture.

图 6-77. (9Eh) MFR\_SERIAL Register Map

23	22	21	20	19	18	17	16
RW	RW	RW	RW	RW	RW	RW	RW
MFR_SERIAL							
15	14	13	12	11	10	9	8
RW	RW	RW	RW	RW	RW	RW	RW
MFR_SERIAL							
7	6	5	4	3	2	1	0
RW	RW	RW	RW	RW	RW	RW	RW
MFR_SERIAL							

LEGEND: R/W = Read/Write; R = Read only

表 6-88. Register Field Descriptions

Bit	Field	Access	Reset	Description
23:00	MFR_SERIAL	RW	NVM	Arbitrary 3-byte Serial Number assigned by manufacturer

Because the value for [MFR\\_SERIAL](#) is included in the NVM memory store used to calculate the [NVM\\_CHECKSUM](#), assigning a unique [MFR\\_SERIAL](#) value also results in a unique [NVM\\_CHECKSUM](#) value.

### 6.6.72 (ADh) IC\_DEVICE\_ID

CMD Address	ADh
Write Transaction:	N/A
Read Transaction:	Read Block
Format:	Unsigned Binary (6 bytes)
Phased:	No

The [IC\\_DEVICE\\_ID](#) command is used to either set or read the type or part number of an IC embedded within a PMBus that is used for the PMBus interface.

**图 6-78. (ADh) IC\_DEVICE\_ID Register Map**

47	46	45	44	43	42	41	40
R	R	R	R	R	R	R	R
IC_DEVICE_ID[47:40]							
39	38	37	36	35	34	33	32
R	R	R	R	R	R	R	R
IC_DEVICE_ID[39:32]							
31	30	29	28	27	26	25	24
R	R	R	R	R	R	R	R
IC_DEVICE_ID[31:24]							
23	22	21	20	19	18	17	16
R	R	R	R	R	R	R	R
IC_DEVICE_ID[23:16]							
15	14	13	12	11	10	9	8
R	R	R	R	R	R	R	R
IC_DEVICE_ID[15:8]							
7	6	5	4	3	2	1	0
R	R	R	R	R	R	R	R
IC_DEVICE_ID[7:0]							

LEGEND: R/W = Read/Write; R = Read only

**表 6-89. Register Field Descriptions**

Bit	Field	Access	Reset	Description
47:0	IC_DEVICE_ID	R	See text.	See the table below.

**表 6-90. IC\_DEVICE\_ID Values**

Byte Number (Bit Indices)	Byte 0 (7:0)	Byte 1 (15:8)	Byte 2 (23:16)	Byte 3 (31:24)	Byte 4 (39:32)	Byte 5 (47:40)
TPSM8D6C24	54h	49h	54h	6Bh	24h	41h

Attempts to write read-only commands cause the CML: invalid command (IVC) fault condition, the TPSM8D6C24 responds as follows:

- Set the CML bit in [STATUS\\_BYTE](#).
- Set the CML\_IVC (bit 7) bit in [STATUS\\_CML](#).
- Notifying the host according to the PMBus 1.3.1 Part II specification section 10.9.3.

### 6.6.73 (AEh) IC\_DEVICE\_REV

CMD Address	AEh
Write Transaction:	N/A
Read Transaction:	Read Block
Format:	Unsigned Binary (2 bytes)
Phased:	No

The [IC\\_DEVICE\\_REV](#) command is used to either set or read the revision of the IC.

图 6-79. (AEh) IC\_DEVICE\_REV Register Field Descriptions

15	14	13	12	11	10	9	8
R	R	R	R	R	R	R	R
MAJOR_REV				MINOR_REV			
7	6	5	4	3	2	1	0
R	R	R	R	R	R	R	R
SUB_MINOR_REV							

LEGEND: R/W = Read/Write; R = Read only

Attempts to write read-only commands cause the CML: invalid command (IVC) fault condition, the TPSM8D6C24 responds as follows:

- Set the CML bit in [STATUS\\_BYTE](#).
- Set the CML\_IVC (bit 7) bit in [STATUS\\_CML](#).

Notifying the host according to the PMBus 1.3.1 Part II specification section 10.9.3.



### 6.6.74 (B1h) USER\_DATA\_01 (COMPENSATION\_CONFIG)

CMD Address	B1h
Write Transaction:	Write Block
Read Transaction:	Read Block
Format:	Unsigned Binary (5 bytes)
Phased:	No
NVM Backup:	EEPROM or Pin Detection
Updates:	Conversion Disable: on-the-fly. Conversion Enable: hardware update blocked. To update hardware after write while enabled, store to NVM with (15h) STORE_USER_ALL and (16h) RESTORE_USER_ALL or cycle AVIN below UVLO.

Configure the control loop compensation.

图 6-80. (B1h) USER\_DATA\_01 (COMPENSATION\_CONFIG) Register Map

39	38	37	36	35	34	33	32
RW	RW	RW	RW	RW	RW	RW	RW
SEL_CZI[1:0]		SEL_CPI[4:0]				SEL_CZI_MUL	
31	30	29	28	27	26	25	24
R	RW	RW	RW	RW	RW	RW	RW
SEL_RVI[5:0]					SEL_CZI[3:2]		
23	22	21	20	19	18	17	16
RW	RW	RW	RW	RW	RW	RW	RW
SEL_CZV[1:0]		SEL_CPV[4:0]				0	
15	14	13	12	11	10	9	8
RW	RW	RW	RW	RW	RW	RW	RW
SEL_RVV[5:0]					SEL_CZV[3:2]		
7	6	5	4	3	2	1	0
RW	RW	RW	RW	RW	RW	RW	RW
0	0	SEL_GMV[1:0]		0	0	SEL_GMI[1:0]	

LEGEND: R/W = Read/Write; R = Read only

表 6-91. Register Field Descriptions

Bit	Field	Access	Reset	Description
25:24,39:38	SEL_CZI[3:0]	RW	NVM	Selects the value of current loop integrating capacitor. $CZI = 6.66 \text{ pF} \times CZI\_MUL \times 2^{SEL\_GMI[1:0]} \times SEL\_CZI[3:0]$
37:33	SEL_CPI[4:0]	RW	NVM	Selects the value of current loop filter capacitor. $CPI = 3.2 \text{ pF} \times SEL\_CPI[4:0]$
32	SEL_CZI_MUL	RW	NVM	Selects the value of current loop integrating capacitor multiplier. 0b: CZI_MUL = 1 1b: CZI_MUL = 2
31:26	SEL_RVI[5:0]	RW	NVM	Selects the value of current loop mid-band gain resistor. $RVI = 5 \text{ k}\Omega \times SEL\_RVI[5:0]$
9:8, 23:22	SEL_CZV[3:0]	RW	NVM	Selects the value of voltage loop integrating capacitor. $CZV = 125 \text{ pF} \times 2^{SEL\_GMV[1:0]} \times SEL\_CZV[3:0]$
21:17	SEL_CPV[4:0]	RW	NVM	Selects the value of voltage loop filter capacitor. $CPV = 6.25 \text{ pF} \times SEL\_CPV[4:0]$
16	Reserved	RW	NVM	Reserved, set to 0b.
15:10	SEL_RVV[5:0]	RW	NVM	Selects the value of voltage loop mid-band gain resistor. $RVV = 5 \text{ k}\Omega \times SEL\_RVV[5:0]$

表 6-91. Register Field Descriptions (续)

Bit	Field	Access	Reset	Description
7:6	Reserved	RW	NVM	Reserved, set to 00b.
5:4	SEL_GMV[1:0]	RW	NVM	Selects the value of voltage error transconductance. $GMV = 25 \mu S \times 2^{SEL\_GMV[1:0]}$
3:2	Reserved	RW	NVM	Reserved, set to 00b.
1:0	SEL_GMI[1:0]	RW	NVM	Selects the value of current error transconductance. $GMI = 25 \mu S \times 2^{SEL\_GMI[1:0]}$

(B1h) [USER\\_DATA\\_01 \(COMPENSATION\\_CONFIG\)](#) can be written to while output conversion is enabled, but updating those values to hardware are blocked. To update the value used by the control loop:

- Disable conversion, then write to (B1h) [USER\\_DATA\\_01 \(COMPENSATION\\_CONFIG\)](#).
- Write to (B1h) [USER\\_DATA\\_01 \(COMPENSATION\\_CONFIG\)](#) while conversion is enabled, store PMBus values to NVM using (15h) [STORE\\_USER\\_ALL](#), clear the (B1h) [USER\\_DATA\\_01 \(COMPENSATION\\_CONFIG\)](#) bit in (EEh) [MFR\\_SPECIFIC\\_30 \(PIN\\_DETECT\\_OVERRIDE\)](#), then cycle AVIN or use the (16h) [RESTORE\\_USER\\_ALL](#) command.

Due to the complexity of translating the 5-byte HEX value of (B1h) [USER\\_DATA\\_01 \(COMPENSATION\\_CONFIG\)](#) into analog compensation values, TI recommends using the tools available on the [TPSM8D6C24 product folder](#) such as the [TPS546x24A Compensation and Pin-Strap Resistor Calculator](#) design tool.

### 6.6.75 (B5h) USER\_DATA\_05 (POWER\_STAGE\_CONFIG)

CMD Address	B5h
Write Transaction:	Write Block (per PMBus Spec, even though 1 data byte)
Read Transaction:	Read Block (per PMBus Spec, even though 1 data byte)
Format:	Unsigned Binary (1 byte)
Phased:	No
NVM Backup:	EEPROM
Updates:	On-the-fly
Max Transaction Time:	1.0 ms
Max Action Delay:	1.0 ms (not time critical)

POWER\_STAGE\_CONFIG allows the user to adjust the VDD5 regulator voltage.

**图 6-81. (B5h) USER\_DATA\_05 (POWER\_STAGE\_CONFIG) Register Map**

7	6	5	4	3	2	1	0
RW	RW	RW	RW	R	R	R	R
SEL_VDD5				Reserved			

LEGEND: R/W = Read/Write; R = Read only

**表 6-92. Register Field Descriptions**

Bit	Field	Access	Reset	Description
7:4	SEL_VDD5	RW	NVM	3h: VDD5 = 3.9 V (Not Recommended for Production) 4h: VDD5 = 4.1 V 5h: VDD5 = 4.3 V 6h: VDD5 = 4.5 V 7h: VDD5 = 4.7 V 8h: VDD5 = 4.9 V 9h: VDD5 = 5.1 V Ah: VDD5 = 5.3 V Other: Invalid
3:0	Reserved	R	0000b	Reserved. Set to 0000b.

Setting 30h is not recommended for production use unless an external VDD5 voltage is provided because the 3.9-V LDO setting can result in a VDD5 voltage less than the VDD5 undervoltage lockout required to enable conversion and can result in the TPSM8D6C24 device being unable to enable conversion without an external VDD5 voltage.

**6.6.76 (D0h) MFR\_SPECIFIC\_00 (TELEMETRY\_CONFIG)**

CMD Address	D0h
Write Transaction:	Write Block
Read Transaction:	Read Block
Format:	Unsigned Binary (6 bytes)
Phased:	No
NVM Backup:	EEPROM
Updates:	On-The-Fly

Configure the priority and averaging for each channel of the internal telemetry system.

The internal telemetry system shares a single ADC across each measurement. The priority setting allows the user to adjust the relative rate of measurement of each telemetry value. The ADC first measures each value with a priority A value. With each pass through all priority A measurements, one priority B measurement is taken. With each pass through all priority B measurements, one priority C measurement is taken.

For example, if output voltage has priority A and output current has priority B, and temperature has priority C, the telemetry sequence is VOUT IOUOT VOUT TEMPERATURE VOUT IOUOT VOUT TEMPERATURE.

**图 6-82. (D0h) MFR\_SPECIFIC\_00 (TELEMETRY\_CONFIG) Register Map**

47	46	45	44	43	42	41	40
RW	RW	RW	RW	RW	RW	RW	RW
Reserved priority		Reserved			Reserved averaging		
39	38	37	36	35	34	33	32
RW	RW	RW	RW	RW	RW	RW	RW
Reserved priority		Reserved			Reserved averaging		
31	30	29	28	27	26	25	24
R	RW	RW	RW	RW	RW	RW	RW
RD_VI_PRI		Reserved			RD_VI_AVG		
23	22	21	20	19	18	17	16
RW	RW	RW	RW	RW	RW	RW	RW
RD_TMP_PRI		Reserved			RD_TMP_AVG		
15	14	13	12	11	10	9	8
RW	RW	RW	RW	RW	RW	RW	RW
RD_IO_PRI		Reserved			RD_IO_AVG		
7	6	5	4	3	2	1	0
RW	RW	RW	RW	RW	RW	RW	RW
RD_VO_PRI		Reserved			RD_VO_AVG		

LEGEND: R/W = Read/Write; R = Read only

**表 6-93. Register Field Descriptions**

Bit	Field	Access	Reset	Description
47:40	Not used	R	00h	Reserved. Set values to 00h.
39:32	Not used	RW	NVM	Reserved. Set values to 03h.
31:30	RD_VI_PRI	RW	NVM	00b: Assign priority A to input voltage telemetry. 01b: Assign priority B to input voltage telemetry. 10b: Assign priority C to input voltage telemetry. 11b: Disable input voltage telemetry.

**表 6-93. Register Field Descriptions (续)**

Bit	Field	Access	Reset	Description
31:24	RD_VI_AVG	RW	NVM	0d - 5d: READ_VIN Rolling average of 2 <sup>N</sup> samples 6d - 7d: Invalid
23:22	RD_TMP_P RI	RW	NVM	00b: Assign priority A to temperature telemetry. 01b: Assign priority B to temperature telemetry. 10b: Assign priority C to temperature telemetry. 11b: Invalid
21:19	Reserved	RW	NVM	Reserved. Set to 000b.
18:16	RD_TMP_A VG	RW	NVM	0d - 5d: READ_TEMPERATURE_1 Rolling average of 2 <sup>N</sup> samples 6d-7d: Invalid
15:14	RD_IO_PRI	RW	NVM	00b: Assign priority A to output current telemetry. 01b: Assign priority B to output current telemetry. 10b: Assign priority C to output current telemetry. 11b: Disable output current telemetry.
13:11	Reserved	RW	NVM	Reserved. Set to 000b.
10:8	RD_IO_AVG	RW	NVM	0d - 5d: READ_IOUT Rolling average of 2 <sup>N</sup> samples 6d - 7d: Invalid
7:6	RD_VO_PRI	RW	NVM	00b: Assign priority A to output voltage telemetry. 01b: Assign priority B to output voltage telemetry. 10b: Assign priority C to output voltage telemetry. 11b: Disable output voltage telemetry.
5:3	Reserved	RW	NVM	Reserved. Set to 000b.
2:0	RD_VO_AV G	RW	NVM	0d - 5d: READ_VOUT Rolling average of 2 <sup>N</sup> samples 6d - 7d: Invalid

Disabling any telemetry value forces the associated READ PMBus command to report 0000h.

Because temperature telemetry is used for overtemperature protection, temperature telemetry cannot be disabled.

**6.6.77 (DAh) MFR\_SPECIFIC\_10 (READ\_ALL)**

CMD Address	DAh
Write Transaction:	NA
Read Transaction:	Read Block
Format:	Unsigned Binary (14 bytes)
Phased:	No
NVM Backup:	No

READ\_ALL provides for a 14-byte BLOCK read of [STATUS\\_WORD](#) and telemetry values to improve bus utilization for polling by combining multiple READ functions into a single command, eliminating the need for multiple address and command code bytes.

**图 6-83. (DAh) MFR\_SPECIFIC\_10 (READ\_ALL) Register Map**

111	110	109	108	107	106	105	104
R	R	R	R	R	R	R	R
Not Supported = 00h							
103	102	101	100	99	98	97	96
R	R	R	R	R	R	R	R
Not Supported = 00h							
95	94	93	92	91	90	89	88
R	R	R	R	R	R	R	R
Not Supported = 00h							
87	86	85	84	83	82	81	80
R	R	R	R	R	R	R	R
Not Supported = 00h							
79	78	77	76	75	74	73	72
R	R	R	R	R	R	R	R
READ_VIN (MSB)							
71	70	69	68	67	66	65	64
R	R	R	R	R	R	R	R
READ_VIN (LSB)							
63	62	61	60	59	58	57	56
R	R	R	R	R	R	R	R
READ_TEMPERATURE1 (MSB)							
55	54	53	52	51	50	49	48
R	R	R	R	R	R	R	R
READ_TEMPERATURE1 (LSB)							
47	46	45	44	43	42	41	40
R	R	R	R	R	R	R	R
READ_IOUT (MSB)							
39	38	37	36	35	34	33	32
R	R	R	R	R	R	R	R
READ_IOUT (LSB)							

31	30	29	28	27	26	25	24
R	R	R	R	R	R	R	R
READ_VOUT (MSB)							
23	22	21	20	19	18	17	16
R	R	R	R	R	R	R	R
READ_VOUT (LSB)							
15	14	13	12	11	10	9	8
R	R	R	R	R	R	R	R
STATUS_WORD (High Byte)							
7	6	5	4	3	2	1	0
R	R	R	R	R	R	R	R
STATUS_BYTE							

LEGEND: R/W = Read/Write; R = Read only

**表 6-94. Register Field Descriptions**

Bit	Field	Access	Reset	Description
111:96	READ_DUTY_CYCLE	R	0000h	Not supported = 0000h
95:80	READ_IIN	R	0000h	Not supported = 0000h
79:64	READ_VIN	R	0000h	READ_VIN (Linear Format)
63:48	READ_TEMPERATURE1	R	0000h	READ_TEMPERATURE1 (Linear Format)
47:32	READ_IOUT	R	0000h	READ_IOUT (Linear Format)
31:16	READ_VOUT	R	0000h	READ_VOUT (ULinear16 Format, Per VOUT_MODE)
15:0	STATUS_WORD	R	0000h	STATUS_WORD

Attempts to write read-only commands cause the CML: invalid command (IVC) fault condition, the TPSM8D6C24 responds as follows:

- Set the CML bit in [STATUS\\_BYTE](#).
- Set the CML\_IVC (bit 7) bit in [STATUS\\_CML](#).

Notifying the host according to the PMBus 1.3.1 Part II specification section 10.9.3.

**6.6.78 (DBh) MFR\_SPECIFIC\_11 (STATUS\_ALL)**

CMD Address	DBh
Write Transaction:	NA
Read Transaction:	Read Block
Format:	Unsigned Binary (7 bytes)
Phased:	No
NVM Backup:	No

STATUS\_ALL provides for a 7-byte block of STATUS command codes, which can reduce bus utilization to read multiple faults.

**图 6-84. (DBh) MFR\_SPECIFIC\_11 (STATUS\_ALL) Register Map**

55	54	53	52	51	50	49	48
R	R	R	R	R	R	R	R
STATUS_MFR							
47	46	45	44	43	42	41	40
R	R	R	R	R	R	R	R
STATUS_OTHER							
39	38	37	36	35	34	33	32
R	R	R	R	R	R	R	R
STATUS_CML							
31	30	29	28	27	26	25	24
R	R	R	R	R	R	R	R
STATUS_TEMPERATURE							
23	22	21	20	19	18	17	16
R	R	R	R	R	R	R	R
STATUS_INPUT							
15	14	13	12	11	10	9	8
R	R	R	R	R	R	R	R
STATUS_IOUT							
7	6	5	4	3	2	1	0
R	R	R	R	R	R	R	R
STATUS_VOUT							

LEGEND: R/W = Read/Write; R = Read only

**表 6-95. Register Field Descriptions**

Bit	Field	Access	Reset	Description
55:48	STATUS_MFR	R	Current Status	STATUS_MFR
47:40	STATUS_OTHER	R	Current Status	STATUS_OTHER
39:32	STATUS_CML	R	Current Status	STATUS_CML
31:24	STATUS_TEMPERATURE	R	Current Status	STATUS_TEMPERATURE



**表 6-95. Register Field Descriptions (续)**

Bit	Field	Access	Reset	Description
23:16	STATUS_ INPUT	R	Current Status	STATUS_ INPUT
15:8	STATUS_ IOOUT	R	Current Status	STATUS_ IOOUT
7:0	STATUS_ VOUT	R	Current Status	STATUS_ VOUT

Attempts to write read-only commands cause the CML: invalid command (IVC) fault condition, the TPSM8D6C24 responds as follows:

- Set the CML bit in [STATUS\\_BYTE](#).
- Set the CML\_IVC (bit 7) bit in [STATUS\\_CML](#).
- Notifying the host according to the PMBus 1.3.1 Part II specification section 10.9.3.

Writes to STATUS\_ALL do not clear asserted status bits.

### 6.6.79 (DCh) MFR\_SPECIFIC\_12 (STATUS\_PHASE)

CMD Address	DCh
Write Transaction:	Write Word
Read Transaction:	Read Word
Format:	Unsigned Binary (2 bytes)
Phased:	Yes
Updates:	On-the-fly
NVM Backup:	No

When **PHASE** = FFh or 80h, reads to this command return a data word detailing which phases have experienced fault conditions. When **PHASE** != FFh, reads to this command return a data word detailing which fault or faults the current PHASE has experienced. PHASE number assignment is per PHASE\_CONFIG. Bits corresponding to unused (unassigned or disabled) phase numbers are always equal to 0b.

图 6-85. (DCh) MFR\_SPECIFIC\_12 (STATUS\_PHASE)

15	14	13	12	11	10	9	8	7	6	5	4	3	2	1	0
R	R	R	R	RW	RW	RW	RW	RW	RW	RW	RW	RW	RW	RW	RW
0	0	0	0	0	0	0	0	0	0	0	0	PH3	PH2	PH1	PH0

LEGEND: R/W = Read/Write; R = Read only

表 6-96. Register Field Descriptions

Bit	Field	Access	Reset	Description
15:4	Reserved	R	0b	Reserved
3	PH3	RW	0b	0b: The TPSM8D6C24 assigned to <b>PHASE</b> = 3d has <i>not</i> experienced a fault. 1b: The TPSM8D6C24 assigned to <b>PHASE</b> = 3d has experienced a fault. Set <b>PHASE</b> = 3d, and read STATUS_WORD or STATUS_ALL for more information.
2	PH2	RW	0b	0b: The TPSM8D6C24 assigned to <b>PHASE</b> = 2d has <i>not</i> experienced a fault. 1b: The TPSM8D6C24 assigned to <b>PHASE</b> = 2d has experienced a fault. Set <b>PHASE</b> = 2d, and read STATUS_WORD or STATUS_ALL for more information.
1	PH1	RW	0b	0b: The TPSM8D6C24 assigned to <b>PHASE</b> = 1d has <i>not</i> experienced a fault. 1b: The TPSM8D6C24 assigned to <b>PHASE</b> = 1d has experienced a fault. Set <b>PHASE</b> = 1d, and read STATUS_WORD or STATUS_ALL for more information.
0	PH0	RW	0b	0b: The TPSM8D6C24 assigned to <b>PHASE</b> = 0d has <i>not</i> experienced a fault. 1b: The TPSM8D6C24 assigned to <b>PHASE</b> = 0d has experienced a fault. Set <b>PHASE</b> = 0d, and read STATUS_WORD or STATUS_ALL for more information.

### 6.6.80 (E4h) MFR\_SPECIFIC\_20 (SYNC\_CONFIG)

CMD Address	E4h
Write Transaction:	Write Byte
Read Transaction:	Read Byte
Format:	Unsigned Binary
Phased:	No
NVM Backup:	EEPROM or Pin Detect
Updates:	On-the-fly

图 6-86. (E4h) MFR\_SPECIFIC\_20 (SYNC\_CONFIG) Register Map

7	6	5	4	3	2	1	0
RW	RW	RW	RW	RW	RW	RW	RW
SYNC_DIR		SYNC_EDGE	10000b				

LEGEND: R/W = Read/Write; R = Read only

表 6-97. Register Field Descriptions

Bit	Field	Access	Reset	Description
7:6	SYNC_DIR	RW	NVM	00b: SYNC disabled 01b: Enable SYNC OUT. 10b: Enable SYNC IN. 11b: Enable Auto Detect SYNC
5	SYNC_EDGE	RW	NVM	0b: Synchronize to falling edge of SYNC. 1b: Synchronize to rising edge of SYNC.
4:0	Not supported	RW	10000b	Not supported. Set to 10000b.

Attempts to write (E4h) MFR\_SPECIFIC\_E4 (SYNC\_CONFIG) to any value outside those specified as valid are considered invalid or unsupported data and cause the TPSM8D6C24 to respond by flagging the appropriate status bits and notifying the host according to the PMBus 1.3.1 Part II specification section 10.9.3.

When SYNC\_DIR = 11b - Enable Auto Detect, the TPSM8D6C24 selects SYNC\_IN or SYNC\_OUT based on the state of the SYNC pin when the Enable condition, as defined by ON\_OFF\_CONFIG, is met. If the SYNC\_PIN is > 2 V or switching faster than 75% of FRQUENCY\_SWITCH, SYNC\_IN is enabled. If the SYNC\_PIN is less than 0.8 V and not switching, SYNC\_OUT is selected.

Loop follower devices in a multi-phase stack are always configured for SYNC\_IN and declare a SYNC\_FAULT in (80h) STATUS\_MFR\_SPECIFIC if enabled before a SYNC signal is present, or if SYNC is lost before being disabled. To prevent such false SYNC\_FAULTs from occurring, it is recommended that multi-phase stacks configure select SYNC\_OUT in (E4h) MFR\_SPECIFIC\_20 (SYNC\_CONFIG) if not using an external synchronization signal.

Changing SYNC\_DIR from SYNC\_IN to SYNC\_OUT while enabled and operating at the lower limit of the SYNC\_IN function (70% of nominal switching frequency) results in the switching frequency remaining at the lower limit of SYNC\_IN until the output is disabled and enabled.

Changing SYNC\_DIR from SYNC\_IN to SYNC\_OUT on a multi-phase stack while conversion is enabled but prevented due to a SYNC\_FAULT will result in the internal oscillator operating at 70% of its nominal frequency. Since this is outside of the compliant SYNC\_IN range of the loop follower device, this can result in unsynchronized operation.

### 6.6.81 (ECh) MFR\_SPECIFIC\_28 (STACK\_CONFIG)

CMD Address	ECh
Write Transaction:	Write Word
Read Transaction:	Read Word
Format:	Unsigned Word
Phased:	No
NVM Backup:	EEPROM or Pin Detect
Updates:	Conversion Disable: see below. Conversion Enable: Read-Only

图 6-87. (ECh) MFR\_SPECIFIC\_28 (STACK\_CONFIG) Register Map

15	14	13	12	11	10	9	8
R	R	R	R	R	R	R	R
Reserved 0000h							
7	6	5	4	3	2	1	0
R	R	R	R	RW	RW	RW	RW
BCX_START				BCX_STOP			

LEGEND: R/W = Read/Write; R = Read only

表 6-98. Register Field Descriptions

Bit	Field	Access	Reset	Description
15:8	Not supported	R	0000h	Reserved. Equal to 0000h.
7:4	BCX_START	R	0000b	BCX_Address for Stack Loop Controller. Equal to 0000b.
3:0	BCX_STOP	RW	NVM	0000b: Standalone, single-phase 0001b: One loop follower, 2-phase 0010b: Two loop followers, 3-phase 0011b: Three loop followers, 4-phase Other: Not supported/invalid

Attempts to write (ECh) MFR\_SPECIFIC\_28 (STACK\_CONFIG) to any value outside those specified as valid are considered invalid or unsupported data and cause TPSM8D6C24 to respond by flagging the appropriate status bits and notifying the host according to the PMBus 1.3.1 Part II specification section 10.9.3.

(ECh) MFR\_SPECIFIC\_28 (STACK\_CONFIG) controls the operation of the BCX\_CLK and BCX\_DAT pins. If the TPSM8D6C24 powers up with (ECh) MFR\_SPECIFIC\_28 (STACK\_CONFIG) equal to 0000h (standalone) the BCX\_CLK and BCX\_DAT functionality is disabled. Changing (ECh) MFR\_SPECIFIC\_28 (STACK\_CONFIG) to a multi-phase configuration does not enable BCX communication until the next power up. To program loop follower devices connected to a loop controller device that was powered up with (ECh) MFR\_SPECIFIC\_28 (STACK\_CONFIG) = 0000h, program (EEh) MFR\_SPECIFIC\_30 (PIN\_DETECT\_OVERRIDE) to default (ECh) MFR\_SPECIFIC\_28 (STACK\_CONFIG) to NVM by setting bit 12 = 0b, (15h) STORE\_USER\_ALL and cycle AVIN power below its UVLO prior to programming other commands in order to enable BCX communication and allow the loop controller device to relay commands to the loop follower devices.

(ECh) MFR\_SPECIFIC\_28 (STACK\_CONFIG) can be changed from 0001h to 0003h to 0000h – 0003h live without requiring an AVIN power cycle since the BCX\_CLK and BCX\_DAT function is enabled at power up.

### 6.6.82 (EDh) MFR\_SPECIFIC\_29 (MISC\_OPTIONS)

CMD Address	EDh
Write Transaction:	Write Word
Read Transaction:	Read Word
Format:	Unsigned Binary (2 bytes)
Phased:	No
NVM Backup:	EEPROM
Updates:	On-the-fly

MFR\_SPECIFIC\_29 is used to configure miscellaneous settings.

**图 6-88. (EDh) MFR\_SPECIFIC\_29 (MISC\_OPTIONS) Register Map**

15	14	13	12	11	10	9	8
RW	RW	RW	RW	RW	RW	RW	RW
PEC	RESET_CNT	RESET_FLT	RESET#	Reserved	Reserved	Reserved	Reserved
7	6	5	4	3	2	1	0
RW	RW	RW	RW	RW	RW	RW	RW
Reserved	Reserved	Reserved	Reserved	PULLUP#	FLT_CNT	ADC_RES	

LEGEND: R/W = Read/Write; R = Read only

**表 6-99. Register Field Descriptions**

Bit	Field	Access	Reset	Description
15	PEC	RW	NVM	0b: PEC Optional. Transactions received without PEC byte are processed. 1b: PEC is required. Transactions received without the PEC byte are rejected as invalid PEC.
14	RESET_CNT	RW	NVM	0b: VOUT_COMMAND is unchanged following a shutdown. 1b: VOUT_COMMAND is changed to VBOOT on a control or OPERATION shutdown.
13	RESET_FLT	RW	NVM	0b: VOUT_COMMAND is unchanged following a fault restart. 1b: VOUT_COMMAND is changed to VBOOT on restart from a fault when fault retry is set to retry after fault.
12	RESET#	RW	NVM	Sets the function of the PGD/RESET_B pin. 0b: PGD/RESET_B functions as PGOOD and internal pullup is disabled. 1b: PGD/RESET_B functions as RESET# and internal pullup is set by bit 3 PULLUP#.
11:3	Reserved	RW	NVM	Reserved. Must be 00000000b
3	PULLUP#	RW	NVM	Sets the pullup of the PGD/RESET_B pin when RESET# = 1b. 0b: Internal pullup of the PGD/RESET_B pin enabled when RESET# = 1b. 1b: Internal pullup of PGD/RESET_B pin disabled when RESET# = 1b.
2	FLT_CNT	RW	NVM	0b: Fault counter counts down one cycle on PWM cycle without fault 1b: Fault counter resets counter to 0 on PWM cycle without fault.
1:0	ADC_RES	RW	NVM	ADC resolution control 00b: Set ADC resolution to 12-bit. 01b: Set ADC resolution to 10-bit. 10b: Set ADC resolution to 8-bit. 11b: Set ADC resolution to 6-bit.

### 6.6.83 (EEh) MFR\_SPECIFIC\_30 (PIN\_DETECT\_OVERRIDE)

CMD Address	EEh
Write Transaction:	Write Word
Read Transaction:	Read Word
Format:	Unsigned Binary (1 byte)
Phased:	No
NVM Backup:	EEPROM
Updates:	On-the-fly (pin detection occurs on POR only)

PMBUS specified that NVM (default or user) stored values overwrite pin-programmed values. Setting a “1” in each bit of this register prevents DEFAULT or USER STORE values from overwriting the pin-programmed value associated that bit.

图 6-89. (EEh) MFR\_SPECIFIC\_30 (PIN\_DETECT\_OVERRIDE) Register Map

15	14	13	12	11	10	9	8
RW	RW	RW	RW	RW	RW	RW	RW
Reserved			STACK_CONFIG	SYNC_CONFIG	Reserved	COMP_CONFIG	ADDRESS
7	6	5	4	3	2	1	0
RW	RW	RW	RW	RW	RW	RW	RW
Reserved		INTERLEAVE	Reserved	TON_RISE	IOUT_OC	FREQ	VOUT

LEGEND: R/W = Read/Write; R = Read only

表 6-100. Register Field Descriptions

Bit	Field	Access	Reset	Description
15:13	Reserved	RW	NVM	Not used and set to 000b.
12	STACK_CONFIG	RW	NVM	0b: At power up or RESTORE, STACK_CONFIG is reset to NVM value. 1b: At power up or RESTORE, STACK_CONFIG is reset to pin-detected value.
11	SYNC_CONFIG	RW	NVM	0b: At power up or RESTORE, SYNC_CONFIG is reset to NVM value. 1b: At power up or RESTORE, SYNC_CONFIG is reset to the pin-detected value.
10	Reserved	RW	NVM	Not used and set to 0b or 1b
9	COMP_CONFIG	RW	NVM	0b: At power up or RESTORE, COMPENSATION_CONFIG is reset to the NVM value. 1b: At power up or RESTORE, COMPENSATION_CONFIG is reset to the pin-detected value.
8	ADDRESS	RW	NVM	0b: At power up or RESTORE, Loop Follower_ADDRESS is reset to the NVM value. 1b: At power up or RESTORE, Loop Follower_ADDRESS is reset to the pin-detected value.
7:6	Reserved	RW	NVM	Not used and set to 00b.
5	INTERLEAVE	RW	NVM	0b: At power up or RESTORE, INTERLEAVE is reset to the NVM value. 1b: At power up or RESTORE, INTERLEAVE is reset to the pin-detected value.
4	Reserved	RW	NVM	Not used and set to 0b or 1b.
3	TON_RISE	RW	NVM	0b: At power up or RESTORE, TON_RISE is reset to the NVM value. 1b: At power up or RESTORE, TON_RISE is reset to the pin-detected value.
2	IOUT_OC	RW	NVM	0b: At power up or RESTORE, IOUT_OC_FAULT_LIMIT and IOUT_OC_WARN_LIMIT are reset to the NVM value. 1b: At power up or RESTORE, IOUT_OC_FAULT_LIMIT and IOUT_OC_WARN_LIMIT are reset to the pin-detected value.
1	FREQ	RW	NVM	0b: At power up or RESTORE, FREQUENCY_SWITCH is reset to the NVM value. 1b: At power up or RESTORE, FREQUENCY_SWITCH is reset to the pin-detected value.

**表 6-100. Register Field Descriptions (续)**

Bit	Field	Access	Reset	Description
0	VOUT	RW	NVM	0b: At power up or RESTORE, VOUT_COMMAND, VOUT_SCALE_LOOP, VOUT_MAX, and VOUT_MIN are reset to the NVM value. 1b: At power up or RESTORE, VOUT_COMMAND, VOUT_SCALE_LOOP, VOUT_MAX, and VOUT_MIN are reset to the pin-detected value.

PIN\_DETECT\_OVERRIDE allows the user to force pin-detected values to override the user store NVM value for various PMBus commands during power-on reset and RESTORE\_USER\_ALL.

### 6.6.84 (EFh) MFR\_SPECIFIC\_31 (DEVICE\_ADDRESS)

CMD Address	EFh
Write Transaction:	Write Byte
Read Transaction:	Read Byte
Format:	Unsigned Binary (1 bytes)
Phased:	No
NVM Backup:	EEPROM or Pin Detect
Updates:	On-the-fly

The (EFh) MFR\_SPECIFIC\_31 (DEVICE\_ADDRESS) command can be used to program or read-back the target device address of digital communication. When (EFh) MFR\_SPECIFIC\_31 (DEVICE\_ADDRESS) is updated, the TPSM8D6C24 updates its target device address and the TPSM8D6C24 stops responding to its prior address and start responding to its new address immediately. Attempts to write to or read from its prior address are NACKed.

The DEVICE\_ADDRESS command can be used to program or read-back the target device address of digital communication. When a target device address is updated, the TPSM8D6C24 starts responding to the new address immediately.

**图 6-90. (EFh) MFR\_SPECIFIC\_31 (DEVICE\_ADDRESS) Register Map**

7	6	5	4	3	2	1	0
R	RW	RW	RW	RW	RW	RW	RW
0	ADDR_PMBUS						

LEGEND: R/W = Read/Write; R = Read only

**表 6-101. Register Field Descriptions**

Bit	Field	Access	Reset	Description
7	Not supported	R	0b	Not supported. Set to b'0.
6:0	ADDR_PMBUS	RW	NVM/ Pinstrap	PMBus target device address

There are a number of target device address values which are reserved in the SMBus specification. The following reserved addresses are invalid and cannot be programmed:

- 0x0C
- 0x28
- 0x37
- 0x61



### 6.6.85 (F0h) MFR\_SPECIFIC\_32 (NVM\_CHECKSUM)

CMD Address	F0h
Write Transaction:	NA
Read Transaction:	Read Word
Format:	Unsigned Binary (2 bytes)
Phased:	No
NVM Backup:	EEPROM
Updates:	At boot-up, and following NVM Store/Restore operations.

NVM\_CHECKSUM reports the CRC-16 (polynomial 0x8005) checksum for the current NVM settings.

**图 6-91. (F0h) MFR\_SPECIFIC\_32 (NVM\_CHECKSUM) Register Map**

15	14	13	12	11	10	9	8
R	R	R	R	R	R	R	R
NVM_CHECKSUM							
7	6	5	4	3	2	1	0
R	R	R	R	R	R	R	R
NVM_CHECKSUM							

LEGEND: R/W = Read/Write; R = Read only

**表 6-102. Register Field Descriptions**

Bit	Field	Access	Reset	Description
15:0	NVM_CHECKSUM	R	Per NVM Settings	CRC16 for EEPROM settings

**6.6.86 (F1h) MFR\_SPECIFIC\_33 (SIMULATE\_FAULT)**

CMD Address	F1h
Write Transaction:	Write Word
Read Transaction:	Read Word
Format:	Unsigned Binary (2 bytes)
Phased:	Yes
NVM Backup:	No

SIMULATE\_FAULT allows the user to simulate fault and warning conditions by triggering the output of the detection circuit for that controls it. Multiple faults can be simulated at once.

**图 6-92. (F1h) MFR\_SPECIFIC\_F1 (SIMULATE\_FAULT) Register Map**

15	14	13	12	11	10	9	8
W/R	W/R	W/R	W/R	W/R	W/R	W/R	W/R
FAULT_PERSI ST	SIM_TEMP_OT F	Reserved	SIM_IOUT_OC F	SIM_VIN_OFF	SIM_VIN_OVF	SIM_VOUT_UV F	SIM_VOUT_OV F
7	6	5	4	3	2	1	0
W/R	W/R	W/R	W/R	W/R	W/R	W/R	W/R
WARN_PERSI T	Reserved	Reserved	SIM_IOUT_OC W	SIM_VIN_UVW	Reserved	SIM_VOUT_UV W	SIM_VOUT_OV W

LEGEND: R/W = Read/Write; R = Read only

**表 6-103. Register Field Descriptions**

Bit	Field	Access	Reset	Description
15	FAULT_PERSI SIST	W/R	0b	0b: Simulated faults are automatically removed after one fault response. 1b: Simulated faults persist until SIMULATE_FAULTS is written again.
14	SIM_TEMP_OT F	W/R	0b	0b: No change 1b: Simulate overtemperature fault.
13	Reserved	W/R	0b	0b: No change 1b: Not used
12	SIM_IOUT_OC F	W/R	0b	0b: No change 1b: Simulate output current overcurrent fault.
11	SIM_VIN_O FF*	W/R	0b	0b: No change 1b: Simulate PVIN undervoltage lockout.
10	SIM_VIN_O VF	W/R	0b	0b: No change 1b: Simulate PVIN overvoltage fault.
9	SIM_VOUT_U VF	W/R	0b	0b: No change 1b: Simulate VOUT undervoltage fault.
8	SIM_VOUT_O VF*	W/R	0b	0b: No change 1b: Simulate VOUT overvoltage fault.
7	WARN_PERSI SIST	W/R	Default Settings	0b: Simulated warnings are automatically removed after one Fault response. 1b: Simulated warnings persist until SIMULATE_FAULTS is written again.
6	Reserved	W/R	Default Settings	0b: No change 1b: Not used
5	Reserved	W/R	Default Settings	0b: No change 1b: Not used
4	SIM_IOUT_OC W	W/R	Default Settings	0b: No change 1b: Simulate output current overcurrent warning.
3	SIM_VIN_U VW	W/R	Default Settings	0b: No change 1b: Simulate PVIN undervoltage warning.
2	Reserved	W/R	Default Settings	0b: No change 1b: Not used

**表 6-103. Register Field Descriptions (续)**

Bit	Field	Access	Reset	Description
1	SIM_VOUT_UVW	W/R	Default Settings	0b: No change 1b: Simulate VOUT undervoltage warning.
0	SIM_VOUT_OVW	W/R	Default Settings	0b: No change, 1b: Simulate VOUT overvoltage warning.

\*Only SIM\_VIN\_OFF and SIM\_VOUT\_OVF are allowed to trigger their analog comparator while conversion is disabled. All other faults, including SIM\_TEMP\_OTF and SIM\_VIN\_OVF, only simulate while conversion is enabled to allow these faults to simulate repeated shutdown and restart responses when FAULT\_PERSIST is selected.

### 6.6.87 (FCh) MFR\_SPECIFIC\_44 (FUSION\_ID0)

CMD Address	FCh
Write Transaction:	Write Word (writes accepted but otherwise ignored)
Read Transaction:	Read Word
Format:	Unsigned Binary (2 bytes)
Phased:	No
NVM Backup:	No

FUSION\_ID0 provides a platform level identification code to be used by Texas Instruments Digital Power Designer for identifying a TI device.

Writes to this command are accepted, but ignored otherwise (the readback value of this command does not change following a write attempt). This command is writable for some TI devices, so to maintain cross-compatibility, the TPSM8D6C24 accepts write transactions to this command as well. No STATUS\_CML bits are set as a result of the receipt of a write attempt to this command.

图 6-93. (FCh) MFR\_SPECIFIC\_44 (FUSION\_ID0) Register Map

15	14	13	12	11	10	9	8
R	R	R	R	R	R	R	R
FUSION_ID0							
7	6	5	4	3	2	1	0
R	R	R	R	R	R	R	R
FUSION_ID0							

LEGEND: R/W = Read/Write; R = Read only

表 6-104. Register Field Descriptions

Bit	Field	Access	Reset	Description
15:0	FUSION_ID0	R	02D0h	Hard coded to 02C0h

### 6.6.88 (FDh) MFR\_SPECIFIC\_45 (FUSION\_ID1)

CMD Address	FDh
Write Transaction:	Block Write (writes accepted but otherwise ignored)
Read Transaction:	Block Read
Format:	Unsigned Binary (6 bytes)
Phased:	No
NVM Backup:	No

FUSION\_ID1 provides a platform level identification code to be used by Texas Instruments Digital Power Designer for identifying a TI device.

Writes to this command are accepted, but ignored otherwise (the readback value of this command does not change following a write attempt). This command is writable for some TI devices, so to maintain cross-compatibility, the TPSM8D6C24 accepts write transactions to this command as well. No **STATUS\_CML** bits are set as a result of the receipt of a write attempt to this command.

**图 6-94. (FDh) MFR\_SPECIFIC\_45 (FUSION\_ID1) Register Map**

47	46	45	44	43	42	41	40
R	R	R	R	R	R	R	R
FUSION_ID1							
39	38	37	36	35	34	33	32
R	R	R	R	R	R	R	R
FUSION_ID1							
31	30	29	28	27	26	25	24
FUSION_ID1							
23	22	21	20	19	18	17	16
R	R	R	R	R	R	R	R
FUSION_ID1							
15	14	13	12	11	10	9	8
R	R	R	R	R	R	R	R
FUSION_ID1							
7	6	5	4	3	2	1	0
R	R	R	R	R	R	R	R
FUSION_ID1							

LEGEND: R/W = Read/Write; R = Read only

**表 6-105. Register Field Descriptions**

Bit	Field	Access	Reset	Description
47:40	FUSION_ID1	R	4Bh	Hard coded to 4Bh
39:32	FUSION_ID1	R	43h	Hard coded to 43h
31:24	FUSION_ID1	R	4Fh	Hard coded to 4Fh
23:16	FUSION_ID1	R	4Ch	Hard coded to 4Ch
15:8	FUSION_ID1	R	49h	Hard coded to 49h
7:0	FUSION_ID1	R	54h	Hard coded to 54h



## 7.2.1 Design Requirements

For this design example, use the input parameters listed in the following table.

**表 7-1. Design Parameters**

Design Parameter		Test Conditions	MIN	TYP	MAX	Unit
$V_{IN}$	Input voltage		5	12	16	V
$V_{IN(ripple)}$	Input ripple voltage	$V_{IN} = 12\text{ V}, I_{OUT} = 20\text{ A}$		0.3		V
$V_{OUT}$	Output voltage			0.8		V
$\Delta V_{O(\Delta V_I)}$	Line regulation	$5\text{ V} \leq V_{IN} \leq 16\text{ V}$			0.5%	
$\Delta V_{O(\Delta I_O)}$	Load regulation	$0\text{ V} \leq I_{OUT} \leq 35\text{ A}$			0.5%	
$V_{PP}$	Output ripple voltage	$I_{OUT} = 35\text{ A}$		20		mV
$\Delta V_{OUT}$	$V_{OUT}$ deviation during load transient	$\Delta I_{OUT} = 10\text{ A}, V_{IN} = 12\text{ V}$		50		mV
$I_{OUT}$	Output current	$5\text{ V} \leq V_{IN} \leq 16\text{ V}$	0		35	A
$I_{OCP}$	Output overcurrent protection threshold			52		A
$f_{SW}$	Switching frequency	$V_{IN} = 12\text{ V}$		550		kHz
$\eta_{Full\ load}$	Full load efficiency	$V_{IN} = 12\text{ V}, I_{OUT} = 35\text{ A}$		80%		
$t_{SS}$	Soft-start time ( $t_{ON\_RISE}$ )			5		ms

## 7.2.2 Detailed Design Procedure

The TPSM8D6C24 provides four pins to program critical PMBus register values without requiring PMBus communication prior to first power up. Please refer to 表 6-7 for the pinstrapping options. Some equations include a variable N, which is the number of channels stacked together. In this standalone device example, the value of N is equal to 1.

### 7.2.2.1 Custom Design With WEBENCH® Tools

[Click here](#) to create a custom design using the TPSM8D6C24 device with the WEBENCH® Power Designer.

1. Start by entering the input voltage ( $V_{IN}$ ), output voltage ( $V_{OUT}$ ), and output current ( $I_{OUT}$ ) requirements.
2. Optimize the design for key parameters such as efficiency, footprint, and cost using the optimizer dial.
3. Compare the generated design with other possible solutions from Texas Instruments.

The WEBENCH Power Designer provides a customized schematic along with a list of materials with real-time pricing and component availability.

In most cases, these actions are available:

- Run electrical simulations to see important waveforms and circuit performance
- Run thermal simulations to understand board thermal performance
- Export customized schematic and layout into popular CAD formats
- Print PDF reports for the design, and share the design with colleagues

Get more information about WEBENCH tools at [www.ti.com/WBENCH](http://www.ti.com/WBENCH).

### 7.2.2.2 Switching Frequency

The MSEL1 pin programs [USER\\_DATA\\_01 \(COMPENSATION\\_CONFIG\)](#) and [FREQUENCY\\_SWITCH](#). The resistor divider ratio for MSEL1 selects the nominal switching frequency. In the design procedure for MSEL1, switching frequency is configured first, then compensation is chosen after output capacitance is determined.

There is a trade-off between higher and lower switching frequencies for buck converters. Higher switching frequencies can produce smaller design size using lower valued inductors and smaller output capacitors compared to a power supply that switches at a lower frequency. However, the higher switching frequency causes extra switching losses, which decrease efficiency and impact thermal performance.

In this design, a moderate switching frequency of 550 kHz achieves both a small design size and a high-efficiency operation. Use the MSEL1 pin program table to select the frequency option. See 表 6-8 for resistor divider code selection. Resistor divider code 6 or 7 or open is needed to set the switching frequency to 550 kHz.

### 7.2.2.3 Output Voltage Setting (VSEL Pin)

The output voltage can be set using the VSEL pin. The resistor divider ratio for VSEL programs the *VOUT\_COMMAND* range, *VOUT\_SCALE\_LOOP* divider, *VOUT\_MIN*, and *VOUT\_MAX* levels according to 表 6-12. Select the resistor divider code for the range of VOUT desired. For this 1-V output example, resistor divider code 2, a single resistor to AGND or floating the VSEL pin can be used.

With the resistor divider code selected for the range of VOUT, select the resistor to AGND code with the *VOUT\_COMMAND* offset and *VOUT\_COMMAND* step from 表 6-13. To calculate the resistor to AGND code subtract the *VOUT\_COMMAND* offset from the target output voltage and divide by the *VOUT\_COMMAND* step. For this example, a single resistor to AGND was used and the result is code 6. A 14.7-k $\Omega$  resistor to AGND at VSEL programs the desired setting.

$$\text{Code} = \frac{V_{\text{OUT}} - V_{\text{OUT\_COMMAND\_Offset}}}{V_{\text{OUT\_COMMAND\_STEP}}} = \frac{0.8 - 0.5}{0.050} = 6 \quad (9)$$

### 7.2.2.4 Compensation Selection (MSEL1 Pin)

The resistor to AGND for MSEL1 selects the (B1h) *USER\_DATA\_01 (COMPENSATION\_CONFIG)* values to program the following voltage loop and current loop gains. For options other than the EEPROM code (MSEL1 shorted to AGND or MSEL1 to AGND resistor code 0), the current and voltage loop zero and pole frequencies are scaled with the programmed switching frequency.

Based on 表 7-2, for a switching frequency of 550k kHz, the TPSM8D6C24 should use an  $I_{\text{LOOP}}$  of 6 and a maximum voltage loop bandwidth of 87 kHz.

表 7-2. Recommended ILOOP Settings

$f_{\text{sw}}$ (kHz)	$I_{\text{LOOP}}$	$V_{\text{BW(max)}}$
325	3	43
375	4	58
450	5	72
550	6	87
650	7	101
750	8	115
900	8	115
900	10	144
1100	8	115
1100	12	173
1300	15	216
1500	8	115
1500	17	245

In order to achieve the desired transient performance,  $V_{\text{LOOP}}$  needs to be selected to satisfy the equation (方程式 10).

$$V_{\text{LOOP}} > \frac{\Delta V_{\text{OUT}}}{\Delta I_{\text{OUT}}} \times \frac{\text{CSA}}{N \times V_{\text{OUT\_SCALE\_LOOP}}} \quad (10)$$

For this design,  $V_{\text{LOOP}} = 4$  is selected.



For  $I_{\text{LOOP}} = 6$ ,  $V_{\text{LOOP}} = 4$ , Compensation Code 24 is selected and MSEL1 is terminated with no resistor divider and resistor to ground code 14, selecting a 68.1-k $\Omega$  resistor.

**备注**

More conservative Current and Voltage Loops can be selected by selecting a lower  $I_{\text{LOOP}}$  gain and reducing the maximum voltage loop bandwidth proportionally.

### 7.2.2.5 Output Capacitor Selection

Output capacitors are selected to meet the output ripple requirements and stabilize the voltage loop below  $V_{\text{BW(max)}}$ .

To stabilize the loop below  $V_{\text{BW(max)}}$ , evaluate the output impedance of available electrolytic and ceramic capacitors at the target voltage loop bandwidth frequency and combine capacitors in parallel to reduce the total output impedance of the capacitor bank below.

$$Z_{\text{OUT}(V_{\text{BW}})} < \frac{\text{CSA}}{N \times V_{\text{LOOP}} \times V_{\text{OUT\_SCALE\_LOOP}}} \quad (11)$$

$$Z_{\text{OUT}(V_{\text{BW}})} < \frac{6.155 \text{ mV/A}}{1 \times 4 \times 0.5} = 3.08 \text{ m}\Omega \quad (12)$$

$$Z_{\text{C}_{47\mu\text{F}}} = \frac{1}{2\pi f_{\text{SW}} C} = \frac{1}{2\pi \times 87 \text{ kHz} \times 47 \mu\text{F}} = 38.9 \text{ m}\Omega \quad (13)$$

$$Z_{\text{C}_{470\mu\text{F}}} = \frac{1}{2\pi f_{\text{SW}} C} = \frac{1}{2\pi \times 87 \text{ kHz} \times 470 \mu\text{F}} = 3.89 \text{ m}\Omega \quad (14)$$

#### 7.2.2.5.1 Output Voltage Ripple

The output-voltage ripple is the second criterion for output capacitor selection. Use [方程式 15](#) to calculate the minimum output capacitance required to meet the output-voltage ripple specification.

$$C_{\text{OUT(min)}} = \frac{I_{\text{RIPPLE}}}{8 \times f_{\text{SW}} \times V_{\text{OUT(RIPPLE)}}} = \frac{9.62 \text{ A}}{8 \times 550 \text{ kHz} \times 20 \text{ mV}} = 110 \mu\text{F} \quad (15)$$

In this case, the target maximum output-voltage ripple is 20 mV. Under this requirement, the minimum output capacitance for ripple is 110  $\mu\text{F}$ . This capacitance value is smaller than the output capacitance required for the transient response, so select the output capacitance value based on the transient requirement. Considering the variation and derating of capacitance, in this design, two 470- $\mu\text{F}$  low-ESR tantalum polymer bulk capacitors and four 47- $\mu\text{F}$  ceramic capacitors were selected to meet the transient specification with sufficient margin. Therefore, the selected nominal  $C_{\text{OUT}}$  is equal to 1128  $\mu\text{F}$ .

With the output capacitance value selected the ESR must be considered. This is an important consideration in this example because it uses mixed output capacitor types. First use [方程式 16](#) to calculate the maximum allowable impedance for the output capacitor bank at the switching frequency to meet the output voltage ripple specification. [方程式 16](#) indicates the output capacitor bank impedance should be less than 2.1 m $\Omega$ . The impedance of the ceramic capacitors is calculated with [方程式 17](#) and the impedance of the bulk capacitor is calculated with [方程式 18](#). The result from [方程式 18](#) shows the impedance of the bulk capacitor at the switching frequency is dominated by its ESR. [方程式 19](#) calculates the total output impedance of the output capacitor bank at the switching frequency to be 1.2 m $\Omega$ , which meets the 2.1-m $\Omega$  requirement.

$$Z_{\text{COUT(Max)}}_{f_{\text{SW}}} = \frac{V_{\text{OUT(RIPPLE)}}}{I_{\text{RIPPLE}}} = \frac{20 \text{ mV}}{9.62 \text{ A}} = 2.1 \text{ m}\Omega \quad (16)$$

$$Z_{\text{CER}_{f_{\text{SW}}}} = \frac{1}{2\pi \times f_{\text{SW}} \times C_{\text{CER}}} = \frac{1}{2\pi \times 550 \text{ kHz} \times (4 \times 47 \mu\text{F})} = 1.5 \text{ m}\Omega \quad (17)$$

$$Z_{\text{BULK\_f}_{\text{sw}}} = \sqrt{\text{ESR}_{\text{BULK}}^2 + \left(\frac{1}{2\pi \times f_{\text{sw}} \times C_{\text{BULK}}}\right)^2} = \sqrt{\left(\frac{10 \text{ m}\Omega}{2}\right)^2 + \left(\frac{1}{2\pi \times 550 \text{ kHz} \times (2 \times 470 \text{ }\mu\text{F})}\right)^2} = 5.3 \text{ m}\Omega \quad (18)$$

$$Z_{\text{COUT\_f}_{\text{sw}}} = \frac{Z_{\text{CER\_f}_{\text{sw}}} \times Z_{\text{BULK\_f}_{\text{sw}}}}{Z_{\text{CER\_f}_{\text{sw}}} + Z_{\text{BULK\_f}_{\text{sw}}}} = \frac{1.5 \text{ m}\Omega \times 5.3 \text{ m}\Omega}{1.5 \text{ m}\Omega + 5.3 \text{ m}\Omega} = 1.2 \text{ m}\Omega \quad (19)$$

### 7.2.2.6 Input Capacitor Selection

The power-stage input-decoupling capacitance (effective capacitance at the PVIN and PGND pins) must be sufficient to supply the high switching currents demanded when the high-side MOSFET switches on, while providing minimal input-voltage ripple as a result. This effective capacitance includes any DC-bias effects. The voltage rating of the input capacitor must be greater than the maximum input voltage with derating. The capacitor must also have a ripple-current rating greater than the maximum input-current ripple to the device during full load. Use [方程式 20](#) to estimate the input RMS current.

$$I_{\text{IN(RMS)}} = \frac{I_{\text{OUT(MAX)}}}{N} \times \sqrt{\frac{V_{\text{OUT}}}{V_{\text{IN(Min)}}} \times \frac{(V_{\text{IN(Min)}} - V_{\text{OUT}})}{V_{\text{IN(Min)}}}} = \frac{35 \text{ A}}{1} \times \sqrt{\frac{0.8 \text{ V}}{5 \text{ V}} \times \frac{(5 \text{ V} - 0.8 \text{ V})}{5 \text{ V}}} = 12.8 \text{ A} \quad (20)$$

The minimum input capacitance and ESR values for a given input voltage-ripple specification,  $V_{\text{IN(ripple)}}$ , are shown in [方程式 21](#) and [方程式 22](#). The input ripple is composed of a capacitive portion ( $V_{\text{RIPPLE(cap)}}$ ) and a resistive portion ( $V_{\text{RIPPLE(esr)}}$ ).

$$C_{\text{IN(Min)}} = \frac{\frac{I_{\text{OUT(MAX)}}}{N} \times V_{\text{OUT}}}{V_{\text{RIPPLE(cap)}} \times V_{\text{IN(Max)}} \times f_{\text{sw}}} = \frac{\frac{35 \text{ A}}{1} \times 0.8 \text{ V}}{0.1 \text{ V} \times 16 \text{ V} \times 550 \text{ kHz}} = 31.8 \text{ }\mu\text{F} \quad (21)$$

$$\text{ESR}_{\text{CIN(Max)}} = \frac{V_{\text{RIPPLE(ESR)}}}{\frac{I_{\text{OUT(Max)}}}{N} + \frac{1}{2} I_{\text{RIPPLE}}} = \frac{0.2 \text{ V}}{\frac{35 \text{ A}}{1} + \frac{1}{2} \times 9.62 \text{ A}} = 5.02 \text{ m}\Omega \quad (22)$$

The value of a ceramic capacitor varies significantly over temperature and the amount of DC bias applied to the capacitor. The capacitance variations because of temperature can be minimized by selecting a dielectric material that is stable over temperature. X5R and X7R ceramic dielectrics are usually selected for power-regulator capacitors because these components have a high capacitance-to-volume ratio and are fairly stable over temperature. The input capacitor must also be selected with consideration of the DC bias. For this example design, a ceramic capacitor with at least a 25-V voltage rating is required to support the maximum input voltage. For this design, allow 0.1-V input ripple for  $V_{\text{RIPPLE(cap)}}$  and 0.2-V input ripple for  $V_{\text{RIPPLE(esr)}}$ . Using [方程式 21](#) and [方程式 22](#), the minimum input capacitance for this design is 31.8  $\mu\text{F}$ , and the maximum ESR is 5.02 m $\Omega$ . For this design example, four 22- $\mu\text{F}$ , 25-V ceramic capacitors, three 6800-pF, 25-V ceramic capacitors, and two additional 100- $\mu\text{F}$ , 25-V low-ESR electrolytic capacitors in parallel were selected for the power stage with sufficient margin. For all designs a minimum input capacitance of 10  $\mu\text{F}$  is required and a maximum input ripple of 500 mV is recommended.

To minimize the high frequency ringing, the high frequency 6800-pF PVIN bypass capacitors must be placed close to power stage.

### 7.2.2.7 Soft Start, Overcurrent Protection, and Stacking Configuration (MSEL2 Pin)

Soft-start time, overcurrent protection thresholds, and stacking configuration can be configured using the MSEL2 pin. The TPSM8D6C24 device support several soft-start times from 0 to 31.75 ms in 250- $\mu\text{s}$  steps (7 bits) selected by the [TON\\_RISE](#) command. Eight times are selectable using the MSEL2 pin. The TPSM8D6C24 device support several low-side overcurrent warn and fault thresholds from 8 to 62 A selected by the [IOUT\\_OC\\_WARN\\_LIMIT](#) and [IOUT\\_OC\\_FAULT\\_LIMIT](#) commands. Four thresholds are selectable using the MSEL2 pin. The response to an OC fault can be changed through PMBus. Lastly, the number of devices stacked is set using the MSEL2 pin.

The resistor divider code for MSEL2 selects the soft-start values. The resistor to AGND determines the number of devices sharing common output and the overcurrent thresholds. Use [表 6-11](#) and [表 6-10](#) to select the resistor to AGND code and resistor divider code needed for the desired configuration.

In this single-phase design, resistor divider code 3 is selected for 5-ms soft start and resistor to AGND code 0 is selected for the highest current limit thresholds and standalone configuration.

### 7.2.2.8 Enable and UVLO

The `ON_OFF_CONFIG` command is used to select the turn-on behavior of the converter. For this example, the EN/UVLO pin or CONTROL pin was used to enable or disable the converter, regardless of the state of `OPERATION`, as long as the input voltage is present and above the UVLO threshold. The EN/UVLO pin is pulled low internally if it is floating.

A resistor divider can be added the EN/UVLO pin to program an additional UVLO. Additionally 0.1 μF can be placed on this pin to filter noise or short glitches. Use [方程式 23](#) and [方程式 24](#) to calculate the resistor values to target a 4.75-V turn-on and a 4.25-V turn-off. Standard resistor values of 30.1 kΩ and 7.50 kΩ are selected for this example. Use [方程式 25](#) and [方程式 26](#) to calculate the thresholds based on selected resistor values.

$$R_{\text{ENTOP}} = \frac{V_{\text{ON}} \times V_{\text{ENFALL}} - V_{\text{OFF}} \times V_{\text{ENRISE}}}{N \times I_{\text{ENHYS}} \times V_{\text{ENRISE}}} = \frac{5.25 \text{ V} \times 0.98 \text{ V} - 4.75 \text{ V} \times 1.05 \text{ V}}{1 \times 5.5 \text{ } \mu\text{A} \times 1.05 \text{ V}} = 27.3 \text{ k}\Omega \quad (23)$$

$$R_{\text{ENBOT}} = \frac{R_{\text{ENTOP}} \times V_{\text{ENFALL}}}{V_{\text{OFF}} - V_{\text{ENFALL}} + N \times I_{\text{ENHYS}} \times R_{\text{ENTOP}}} = \frac{30.1 \text{ k}\Omega \times 0.98 \text{ V}}{4.75 \text{ V} - 0.98 \text{ V} + 1 \times 5.5 \text{ } \mu\text{A} \times 30.1 \text{ k}\Omega} = 7.50 \text{ k}\Omega \quad (24)$$

$$V_{\text{ON}} = \frac{V_{\text{ENRISE}} \times (R_{\text{ENBOT}} + R_{\text{ENTOP}})}{R_{\text{ENBOT}}} = \frac{1.05 \text{ V} \times (7.50 \text{ k}\Omega + 30.1 \text{ k}\Omega)}{7.50 \text{ k}\Omega} = 5.26 \text{ V} \quad (25)$$

$$V_{\text{OFF}} = \frac{V_{\text{ENFALL}} \times (R_{\text{ENBOT}} + R_{\text{ENTOP}})}{R_{\text{ENBOT}}} - N \times I_{\text{ENHYS}} \times R_{\text{ENTOP}} = \frac{0.98 \text{ V} \times (8.66 \text{ k}\Omega + 30.1 \text{ k}\Omega)}{8.66 \text{ k}\Omega} - 1 \times 5.5 \text{ } \mu\text{A} \times 30.1 \text{ k}\Omega = 4.22 \text{ V} \quad (26)$$

### 7.2.2.9 ADRSEL

In this example, the ADRSEL pin is left floating. This sets the PMBus loop follower address to the EEPROM value, 0x24h (36d) by default, and the SYNC pin to auto detect with 0 degrees phase shift. Use [表 6-14](#) and [表 6-15](#) to select the resistor to AGND code and resistor divider code needed for the desired configuration.

If through pinstrapping, the desired address is not possible with the SYNC pin set to auto detect and synchronization is not needed in the application, the SYNC pin should be configured for SYNC\_OUT. The device still regulates normally with the SYNC pin configured for SYNC\_IN, however, if there is not clock input to the SYNC pin, the device declares a SYNC fault in the `STATUS_MFR_SPECIFIC` command.

### 7.2.2.10 BCX\_CLK and BCX\_DAT

For a standalone device, the BCX\_CLK and BCX\_DAT pins are not used. As shown in [表 6-5](#), TI recommends grounding them to the thermal pad.

### 7.2.3 Application Curves

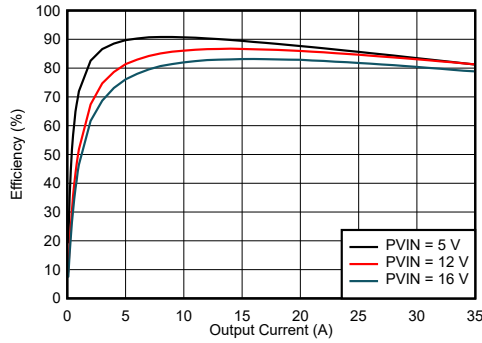

$V_{OUT} = 0.8\text{ V}$        $L = 220\text{ nH}$       Snubber =  $1\text{ nF} + 1\ \Omega$   
 $f_{SW} = 550\text{ kHz}$        $R_{DCR} = 0.2\text{ m}\Omega$        $R_{BOOT} = 0\ \Omega$

图 7-1. Efficiency vs Output Current

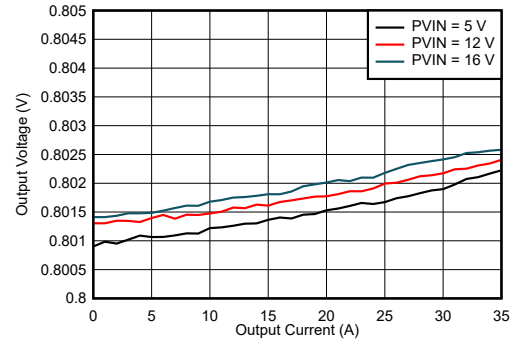

$V_{IN} = 12\text{ V}$        $V_{OUT} = 0.8\text{ V}$

图 7-2. Load Regulation

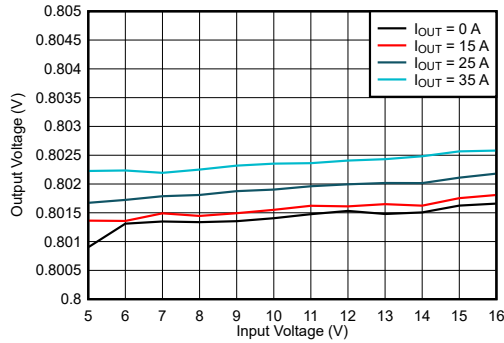

$V_{OUT} = 0.8\text{ V}$

图 7-3. Line Regulation

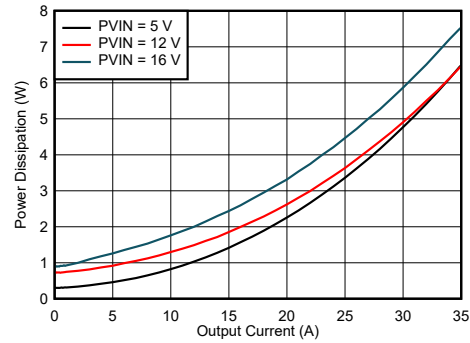

$V_{OUT} = 0.8\text{ V}$

图 7-4. Power Dissipation

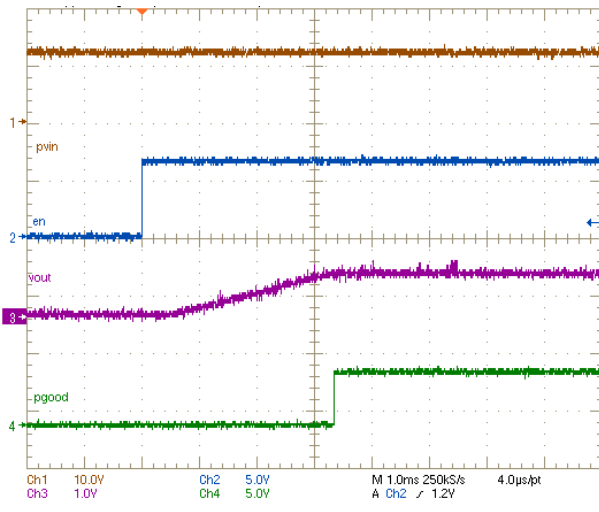

$V_{IN} = 12\text{ V}$        $V_{OUT} = 0.8\text{ V}$        $I_{OUT} = 35\text{ A}$

图 7-5. Start-Up from EN/UVLO

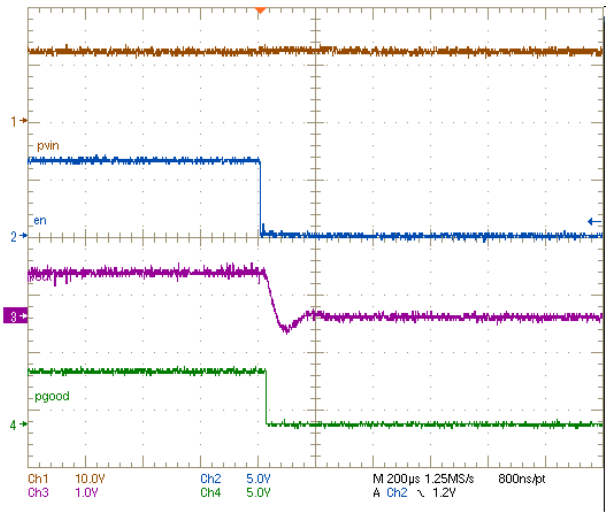

$V_{IN} = 12\text{ V}$        $V_{OUT} = 0.8\text{ V}$        $I_{OUT} = 35\text{ A}$

图 7-6. Shutdown from CNTL

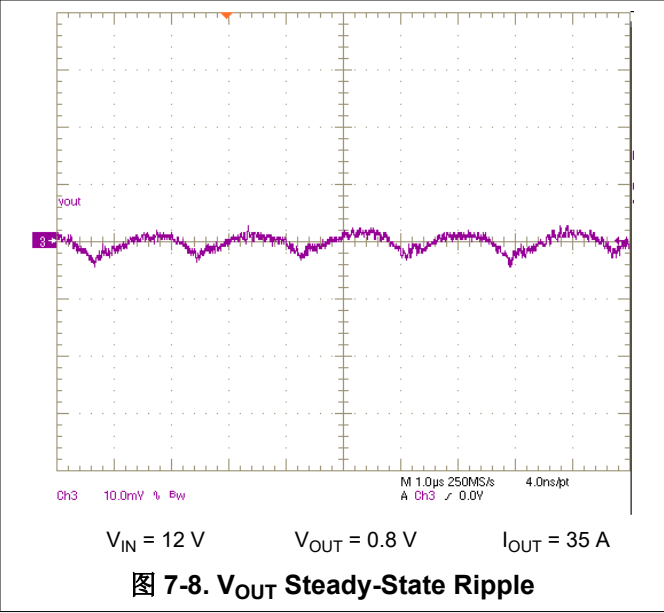
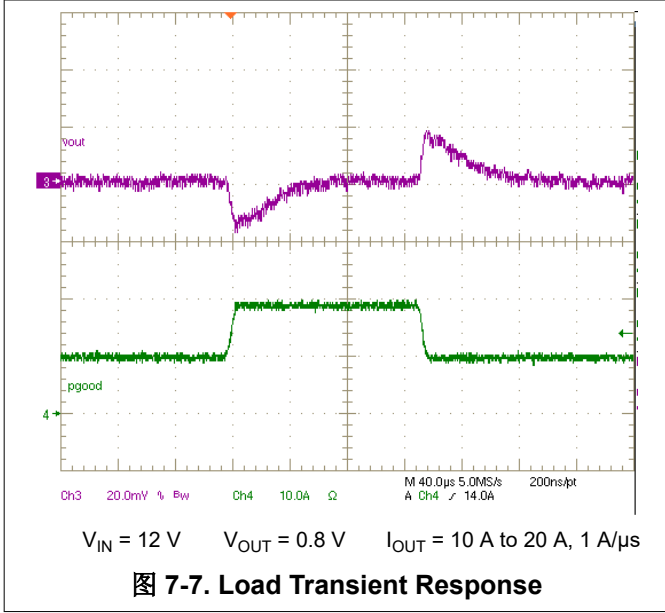

### 7.3 Two-Phase Application

Use the following design procedure to select key component values for two-phase design. The appropriate behavioral options can be set through PMBus. Refer to 节 7.2.2 for the equations used to calculate the component values in this example. The only difference is to increase value of N to 2 because there are two devices stacked for a two-phase design. This procedure can also be used as reference for three-phase and four-phase designs. Again the only difference is to increase the value of N to 3 and 4 for a three-phase and four-phase design, respectively.

WEBENCH includes support for creating two-phase designs. The [TPS546x24A Compensation and Pin-Strap Resistor Calculator](#) can also be used to aid in design calculations and pinstrap resistor selection.



图 7-9. TPSM8D6C24 Two-Phase Application

#### 7.3.1 Design Requirements

For this design example, use the input parameters listed in the following table.

表 7-3. Design Parameters

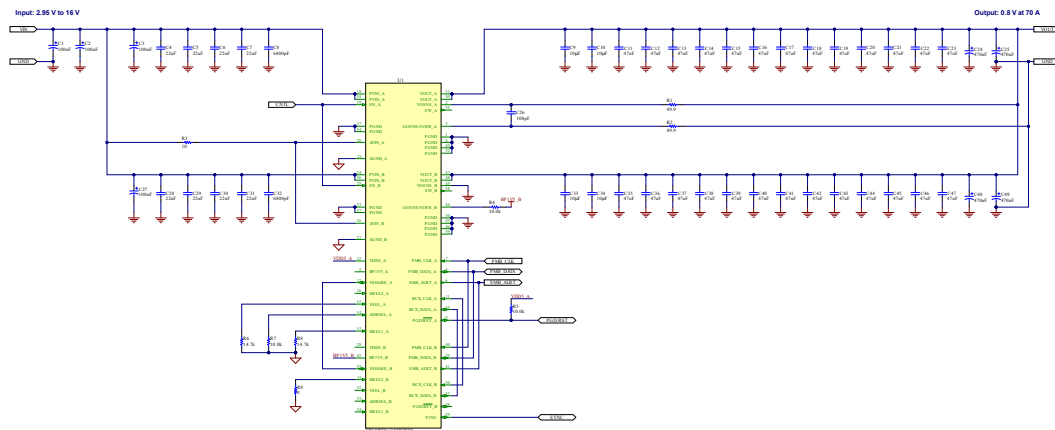
DESIGN PARAMETER		TEST CONDITIONS	MIN	TYP	MAX	UNIT
V <sub>IN</sub>	Input voltage		5	12	16	V
V <sub>IN(ripple)</sub>	Input ripple voltage	V <sub>IN</sub> =12 V, I <sub>OUT</sub> = 20 A		0.3		V
V <sub>OUT</sub>	Output voltage			0.8		V
ΔV <sub>O(ΔV<sub>I</sub>)</sub>	Line regulation	5 V ≤ V <sub>IN</sub> ≤ 16 V			0.5%	
ΔV <sub>O(ΔI<sub>O</sub>)</sub>	Load regulation	0 V ≤ I <sub>OUT</sub> ≤ 70 A			0.5%	
V <sub>PP</sub>	Output ripple voltage	I <sub>OUT</sub> = 50 A		20		mV

表 7-3. Design Parameters (续)

DESIGN PARAMETER		TEST CONDITIONS	MIN	TYP	MAX	UNIT
$\Delta V_{OUT}$	$V_{OUT}$ deviation during load transient	$\Delta I_{OUT} = 20 \text{ A}$ , $V_{IN} = 12 \text{ V}$		50		mV
$I_{OUT}$	Output current	$5 \text{ V} \leq V_{IN} \leq 16 \text{ V}$	0		70	A
$I_{OCP}$	Output overcurrent protection threshold			80		A
$F_{SW}$	Switching frequency	$V_{IN} = 12 \text{ V}$		550		kHz
$\eta_{Full \text{ load}}$	Full load efficiency	$V_{IN} = 12 \text{ V}$ , $I_{OUT} = 70 \text{ A}$		80%		
$t_{SS}$	Soft-start time ( $T_{ON\_RISE}$ )			3		ms

### 7.3.2 Two-Phase Detailed Design Procedure

For the 2-phase application, the design process is similar to that of the single phase, except:

- In selecting the voltage loop compensation,  $N = 2$  divides the effective current sense amplifier gain in half as the two phases operate in parallel, each delivering equal current, doubling the current gain of the converter.
- For ceramic input bypassing capacitors, it is recommended that each phase have sufficient bypassing to support it as if it were a single-phase output. While there is some channel to channel current sharing, layout and trace inductance often results in actual ripple current sharing being significantly lower than the ideal input ripple cancellation.
- MSEL2 of the primary channel (MSEL2\_A) is selected for a 2-phase converter with 3-ms  $T_{ON\_RISE}$  and the maximum current limit by being left open.
- VSEL and ADRSEL of the primary channel are programmed the same as a single phase converter.
- MSEL2 of the follower channel (MSEL2\_B) is shorted to AGND to select follower of a 2-phase converter with the maximum current limit setting.
- GOSNS/FLWR\_B is pulled up to BP1V5 to set channel B to a follower, using Channel A's voltage regulation and error amplifier as well as PMBus interface.
- VSHARE\_A and VSHARE\_B are connected together along with BCX\_CLK A and B, and BCX\_DAT A and B.
- MSEL1, VSEL, ADRSEL, PGOOD, PMB\_CLK, and PMB\_DAT on Channel B are all unused, and connected to GND.

#### 7.3.2.1 Switching Frequency

Only the primary channel needs a resistor divider at the MSEL1 pin to program [USER\\_DATA\\_01 \(COMPENSATION\\_CONFIG\)](#) and [FREQUENCY\\_SWITCH](#). The MSEL1 pin of secondary channels are not used. In this design, a moderate switching frequency of 550 kHz achieves both a small solution size and a high-efficiency operation. Use the MSEL1 pin program table to select the frequency option. See [表 6-8](#) for resistor divider code selection. With 550-kHz switching frequency, a single resistor to AGND can be used to program compensation settings 7 to 25. To program all 32 compensation settings possible through MSEL1, resistor divider code 6 or 7 sets the switching frequency to 550 kHz.

#### 7.3.2.2 Output Voltage Setting (VSEL Pin)

Only the loop controller device (U1) needs a resistor divider at the VSEL pin to program the output voltage. The VSEL pin of loop follower devices are not used. The resistor divider code selected for this 0.8-V output example using [表 6-12](#) is a single resistor to AGND. With the resistor divider code selected for the range of  $V_{OUT}$ , select the resistor to AGND code with the  $V_{OUT\_COMMAND}$  Offset and  $V_{OUT\_COMMAND}$  step from the [表 6-13](#). With  $V_{OUT} = 0.8 \text{ V}$ ,  $V_{OUT\_COMMAND}_{(Offset)} = 0.5 \text{ V}$  and  $V_{OUT\_COMMAND}_{(STEP)} = 0.05$ , the result is code 6. A 14.7-k $\Omega$  resistor to AGND at VSEL programs the desired setting.

#### 7.3.2.3 Compensation Selection (MSEL1 Pin)

Only the loop controller device (U1) uses the resistor to AGND for MSEL1 to program the [\(B1h\) USER\\_DATA\\_01 \(COMPENSATION\\_CONFIG\)](#) values to set the following voltage loop and current loop gains. The MSEL1 pin of the loop follower devices are not used. For options other than the EEPROM code (MSEL1



shorted to AGND or MSEL1 to AGND resistor code 0), the current and voltage loop zero and pole frequencies are scaled with the programmed switching frequency. See 节 7.2.2.4 for more details.

### 7.3.2.4 Output Capacitor Selection

The target maximum output-voltage ripple is 20 mV. Under this requirement, the minimum output capacitance for ripple is 110  $\mu\text{F}$ . Depending on the duty cycle and the number of phases, there can also be some inductor ripple current cancellation. This reduces the amount of ripple current the capacitors need to absorb, reducing the output voltage ripple. This capacitance value is smaller than the output capacitance required for the transient response, so select the output capacitance value based on the transient requirement. Considering the variation and derating of capacitance, in this design, four 470- $\mu\text{F}$  low-ESR tantalum polymer bulk capacitors and twenty-six 47- $\mu\text{F}$  ceramic capacitors were selected to meet the transient specification with sufficient margin. The selected nominal  $C_{\text{OUT}}$  is equal to 3102  $\mu\text{F}$ . The 470- $\mu\text{F}$  capacitors selected have an ESR of 10 m $\Omega$ .

With the output capacitance value selected, the ESR must be considered because this example uses mixed output capacitor types. First, use 方程式 16 to calculate the maximum allowable impedance for the output capacitor bank at the switching frequency to meet the output voltage ripple specification. 方程式 16 indicates the output capacitor bank impedance should be less than 2.1 m $\Omega$ . The impedance of the ceramic capacitors alone is calculated with 方程式 17 to be 0.2 m $\Omega$ . This is much less than the calculated maximum, so the ESR of tantalum polymer capacitors does not need to be considered for the output ripple specification.

### 7.3.2.5 Input Capacitor Selection

Using 方程式 20, the maximum input RMS current is 12.8 A and the input capacitors must be rated to handle this. When calculating this, the maximum output current should be divided by the number of phases. The output current is divided by the number of phases because the switching nodes are interleaved. Interleaving the switching node effectively divides the amplitude of the current pulses the input capacitor by the number of phases. With the 16-V maximum input in this example, a ceramic capacitor with at least a 25-V voltage rating is required to support the maximum input voltage.

For this design, allow 0.1-V input ripple for  $V_{\text{RIPPLE}(\text{cap})}$  and 0.2-V input ripple for  $V_{\text{RIPPLE}(\text{esr})}$ . Using 方程式 21 and 方程式 22, the minimum input capacitance for this design is 31.8  $\mu\text{F}$  and the maximum ESR is 5.02 m $\Omega$ , respectively. Again, the maximum output current should be divided by the number of phases and the calculated capacitance must be placed near the loop controller converter and all of the loop follower converters. Eight 22- $\mu\text{F}$ , 25-V ceramic capacitors and six 6800-pF, 25-V ceramic capacitors in parallel were selected to bypass the power stage with sufficient margin. Additionally, four 100- $\mu\text{F}$ , 25-V low-ESR electrolytic capacitors were placed on the input to minimize deviations on the input during transients. These capacitors are distributed equally between the phases. To minimize the high frequency ringing, the high frequency 6800-pF PVIN bypass capacitors must be placed close to power stage.

When stacking converters the amount of input RMS current and the amount of input capacitance required can be further reduced. The amount of ripple cancellation depends on the number of phases and the duty cycle. PCB inductance between the phases can also reduce the effects of ripple cancellation. The calculations given in this example ignore the effects of ripple cancellation.

### 7.3.2.6 GOSNS/Loop Follower Pin of Loop Follower Devices

Loop follower devices must have their GOSNS/Loop Follower pin tied to BP1V5 through a resistor. A 10-k $\Omega$  resistor is recommended.

### 7.3.2.7 Soft Start, Overcurrent Protection, and Stacking Configuration (MSEL2 Pin)

The resistor divider code for MSEL2 pin of the loop controller device (U1) selects the soft-start values. The resistor to AGND determines the number of devices sharing common output and the overcurrent thresholds. Use 表 6-10 and 表 6-11 to select the resistor values. In this two-phase design, the desired settings can be selected by floating the MSEL2 pin. This selects 3-ms soft-start time, the highest current limit thresholds and two-phase configuration.



In stackable configuration, loop follower devices use the resistor from MSEL2 to AGND to program [IOUT\\_OC\\_WARN\\_LIMIT](#), [IOUT\\_OC\\_FAULT\\_LIMIT](#), [MFR\\_SPECIFIC\\_28 \(STACK\\_CONFIG\)](#), and [INTERLEAVE](#). The loop follower receive all other pin programmed values from the loop controller over the back-channel communication (BCX\_CLK and BCX\_DAT) as part of the power-on reset function. In this two-phase design, the desired settings can be selected by shorting the MSEL2 pin of the loop follower device to AGND. This selects the highest current limit thresholds and programs the loop follower device to be the 180° out of phase from the loop controller device.

#### **7.3.2.8 Enable, UVLO**

TI recommends connecting the EN/UVLO pins of stacked devices together. When this is done, the hysteresis current is multiplied by the number devices stacked. This increased hysteresis current must be included in calculations for a resistor divider to the EN/UVLO pins. See [节 7.2.2.8](#) for more details.

#### **7.3.2.9 VSHARE Pin**

When using a stacked configuration, bypass the VSHARE pin of each device to AGND with a 33 pF or larger capacitor. This capacitor is used to prevent external noise from adding to the VSHARE signal between stacked devices.

##### **7.3.2.9.1 ADRSEL Pin**

Only the loop controller device (U1) needs a resistor divider at the ADRSEL pin. In this example, the ADRSEL pin is left floating. This sets the PMBus loop follower address to the EEPROM value, 0x24h (36d) by default, and the SYNC pin to auto detect with 0 degrees phase shift. Use [表 6-14](#) and [表 6-15](#) to select the resistor to AGND code and resistor divider code needed for the desired configuration.

#### **7.3.2.10 SYNC Pin**

The SYNC pins of stacked devices must be connected together. Loop follower devices are always configured for SYNC\_IN while the loop controller device (U1) can be configured for auto-detect, SYNC\_IN or SYNC\_OUT.

#### **7.3.2.11 VOSNS Pin of Loop Follower Devices**

The VOSNS pin of loop follower devices can be used to monitor voltages other than VOUT through the [READ\\_VOUT](#) command. A resistor divider must be used to scale to voltage at VOSNS to be less than 0.75 V. The appropriate phase must be selected using the [PHASE](#) command.

#### **7.3.2.12 Unused Pins of Loop Follower Devices**

Multiple pins of loop follower devices are not used and TI recommends grounding to the thermal pad. See [表 6-5](#) for more information.

### 7.3.3 Application Curves

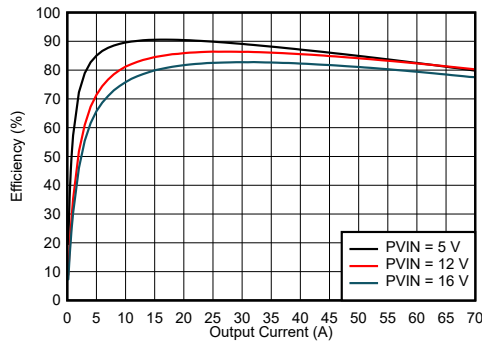

$V_{OUT} = 0.8\text{ V}$       Snubber = 1 nF + 1  $\Omega$   
 $f_{SW} = 550\text{ kHz}$        $R_{BOOT} = 0\ \Omega$

图 7-10. Efficiency vs Output Current

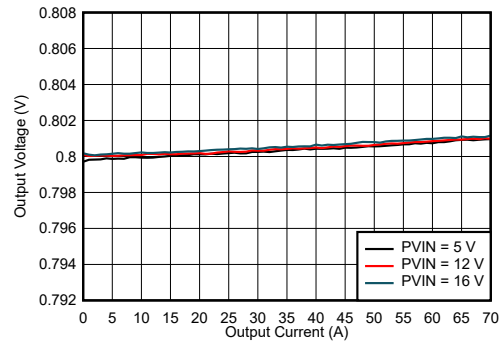

$V_{OUT} = 0.8\text{ V}$        $f_{SW} = 550\text{ kHz}$

图 7-11. Load Regulation

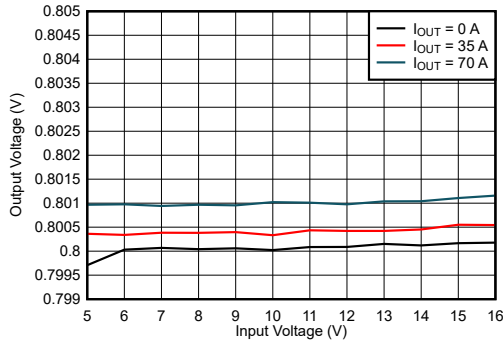

$V_{OUT} = 0.8\text{ V}$        $f_{SW} = 550\text{ kHz}$

图 7-12. Line Regulation

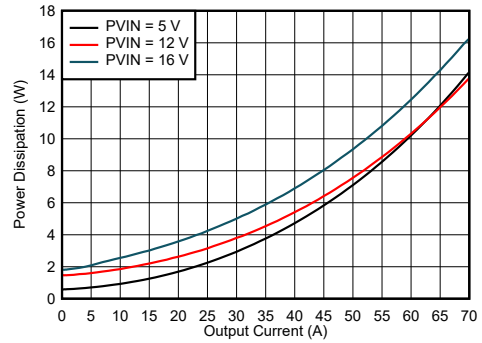

$V_{OUT} = 0.8\text{ V}$        $f_{SW} = 550\text{ kHz}$

图 7-13. Power Dissipation

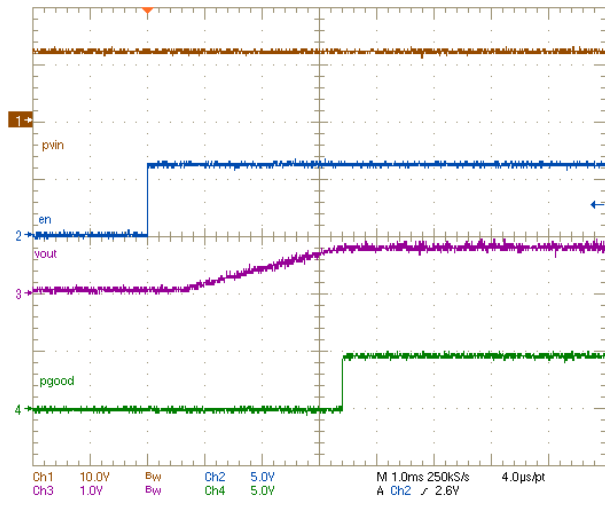

$V_{IN} = 12\text{ V}$        $V_{OUT} = 0.8\text{ V}$        $I_{OUT} = 70\text{ A}$   
 $f_{SW} = 550\text{ kHz}$

图 7-14. Start-Up from EN/UVLO

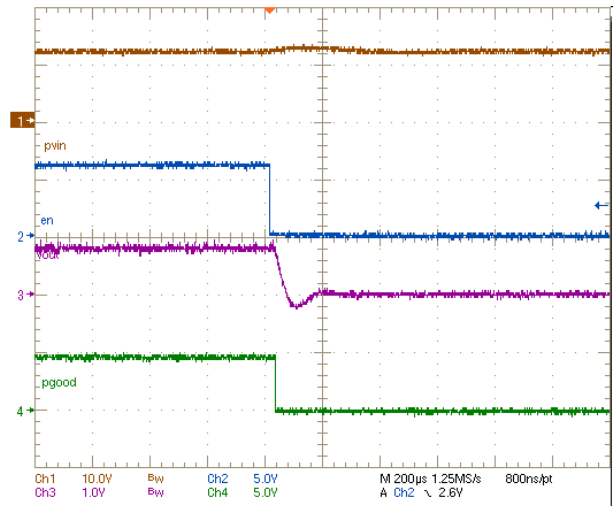

$V_{IN} = 12\text{ V}$        $V_{OUT} = 0.8\text{ V}$        $I_{OUT} = 70\text{ A}$   
 $f_{SW} = 550\text{ kHz}$

图 7-15. Shutdown from CNTL

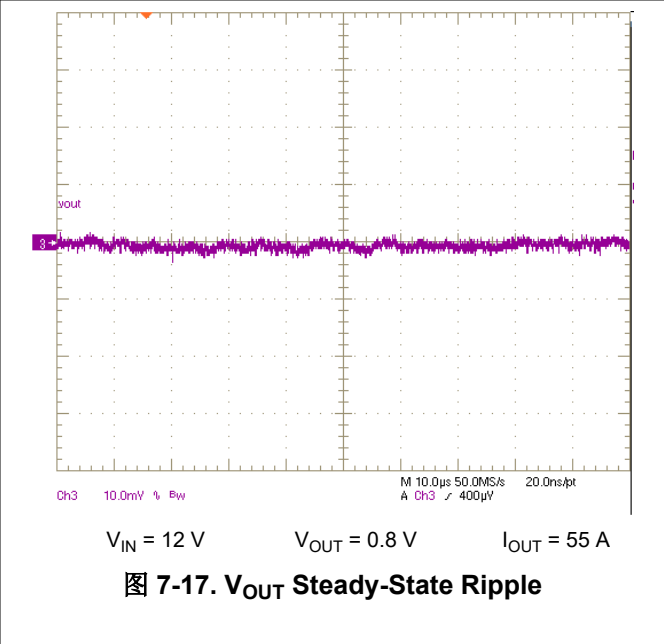
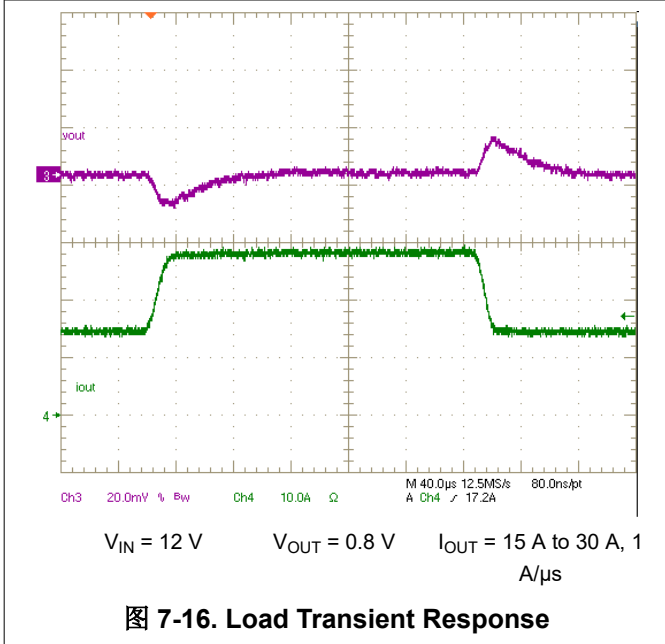

### 7.4 Four-Phase Application

图 7-18 gives an example of four-phase design using the TPSM8D6C24 modules.



图 7-18. TPSM8D6C24 Four-Phase Application

## 7.5 Power Supply Recommendations

The TPSM8D6C24 is designed to operate from split input voltage supplies. AVIN is designed to operate from 2.95 V to 18 V. AVIN must be powered to enable POR, PMBus communication, or output conversion. For AVIN voltages less than 4 V, VDD5 must be supplied with an input voltage greater than 4 V to enable switching. PVIN is designed to operate from 2.95 V to 16 V. PVIN must be powered to enable switching, but not for POR or PMBus communication. The TPSM8D6C24 can be operated from a single 4-V or higher supply voltage by connecting AVIN to PVIN. TI recommends a 10- $\Omega$  resistor between AVIN and PVIN to reduce switching noise on AVIN. See the recommendations in [节 7.6](#).

## 7.6 Layout

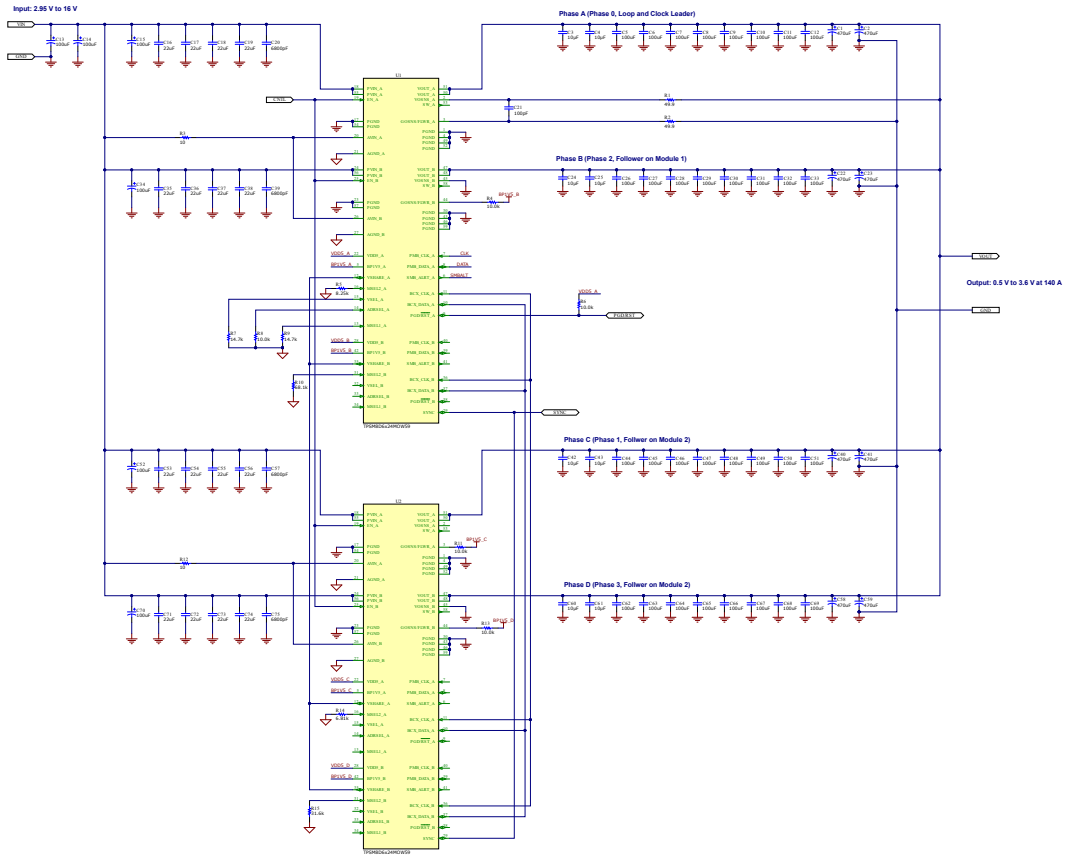
### 7.6.1 Layout Guidelines

Layout is critical for good power-supply design. [节 7.6.2](#) shows the recommended PCB-layout configuration. A list of PCB layout considerations using these devices is listed as follows:

- As with any switching regulator, several power or signal paths exist that conduct fast switching voltages or currents. Minimize the loop area formed by these paths and their bypass connections.
- Bypass the PVIN pins to PGND with a low-impedance path. Place the input bypass capacitors of the power-stage as close as physically possible to the PVIN and PGND pins. A high-frequency bypass capacitor is integrated to reduce switching spikes and EMI. Additional EMI bypass capacitor can be placed on the other side of the PCB directly underneath the device to keep a minimum loop.
- The AVIN bypass capacitor should be placed close to the AVIN pin and provide a low-impedance path to PGND at the thermal pad.
- Keep signal components local to the device, and place them as close as possible to the pins to which they are connected. These components include the VOSNS and GOSNS series resistors and differential filter capacitor as well as MSEL1, MSEL2, VSEL, and ADRSEL resistors. Those components can be terminated to AGND with a minimum return loop or bypassed to the copper area of a separate low-impedance analog ground (AGND) that is isolated from fast switching voltages and current paths and has single connection to PGND on the thermal pad through the AGND pin. For placement recommendations, see [节 7.6.2](#).
- The PGND pins must be directly connected to the thermal pad of the device on the PCB, with a low-noise, low-impedance path.
- Route the VOSNS and GOSNS lines from the output capacitor bank at the load back to the device pins as a tightly coupled differential pair. These traces must be kept away from switching or noisy areas which can add differential-mode noise.
- Use caution when routing of the SYNC, VSHARE, BCX\_CLK, and BCX\_DAT traces for stackable configurations. The SYNC trace carries a rail-to-rail signal and should be routed away from sensitive analog signals, including the VSHARE, VOSNS, and GOSNS signals. The VSHARE traces must also be kept away from fast switching voltages or currents formed by the PVIN, AVIN, SW, and VDD5 pins.

### 7.6.2 Layout Example



图 7-19. Top-Layer Components (Top View)



图 7-20. Bottom-Layer Components (Top View)

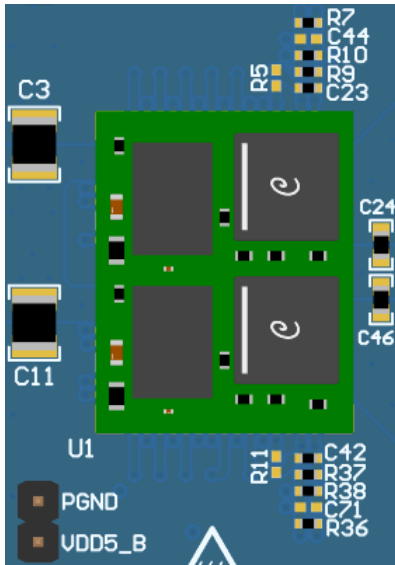

图 7-21. Top-Layer Layout (Top View)

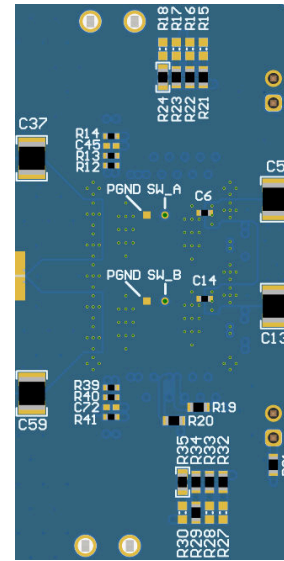

图 7-22. Bottom-Layer Layout (Top View)

### 7.6.2.1 Thermal Performance on the TI EVM

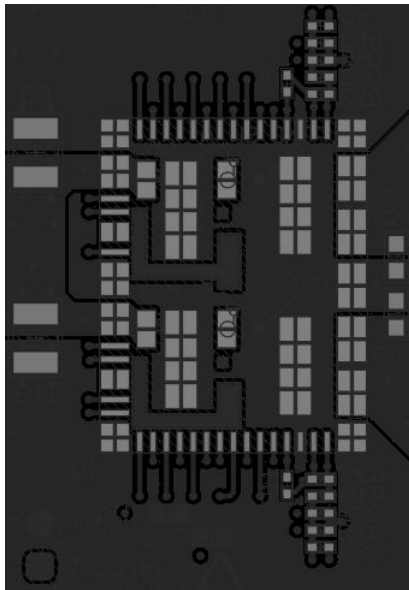
Test conditions:  $f_{SW} = 550 \text{ kHz}$ ,  $V_{IN} = 12 \text{ V}$ ,  $V_{OUTA} = 1 \text{ V}$ ,  $V_{OUTB} = 1.2 \text{ V}$ ,  $I_{OUTA} = I_{OUTB} = 35 \text{ A}$ , Airflow = 200LFM, Peak module temp:  $100^\circ\text{C}$

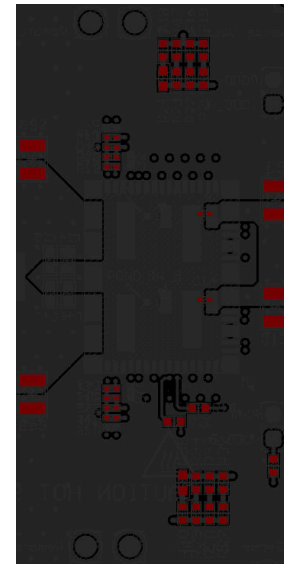

图 7-23. Thermal Image at  $25^\circ\text{C}$  Ambient, 12 Vin, 0.8V and 1.2 Vout, 35 A, 550 kHz

Test conditions:

$f_{SW} = 600 \text{ kHz}$ ,  $V_{IN} = 12 \text{ V}$ ,  $V_{OUT} = 0.8 \text{ V}$ ,  $I_{OUT} = 70 \text{ A}$ , Airflow = 200LFM

Peak module temp:  $99^\circ\text{C}$

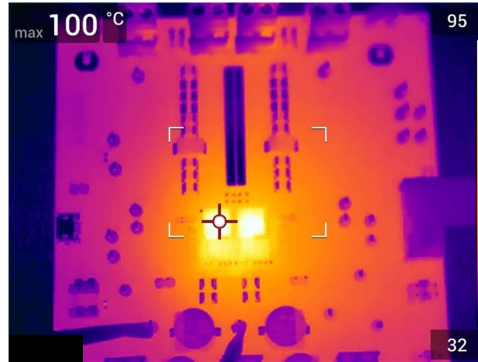

图 7-24. Thermal Image at  $25^\circ\text{C}$  Ambient, 12 Vin, 0.8 Vout, 70 A, 550 kHz

### 7.6.2.2 EMI

The TPSM8D6C24 is compliant with EN55011 Class-B radiated emissions. 图 7-25 shows radiated emissions plots at 12  $V_{IN}$  dual 1.0  $V_{OUT}$  35-A per channel.

The EMI plots were measured using the standard TPSM8D6C24-2V0EVM.

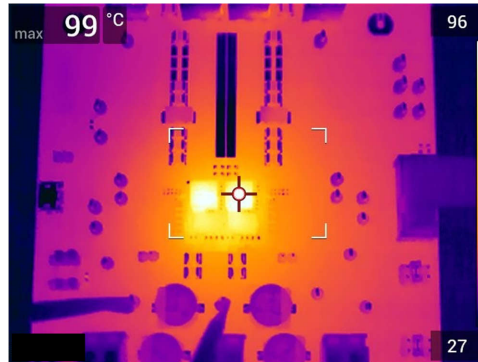

图 7-25. Radiated Emissions 12-V Input, 1.0-V Outputs, 35-A/Output Load

## 8 Device and Documentation Support

### 8.1 Device Support

#### 8.1.1 第三方产品免责声明

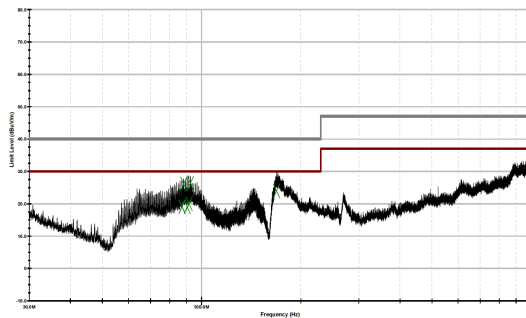
TI 发布的与第三方产品或服务有关的信息，不能构成与此类产品或服务或保修的适用性有关的认可，不能构成此类产品或服务单独或与任何 TI 产品或服务一起的表示或认可。

#### 8.1.2 Development Support

##### 8.1.2.1 Texas Instruments Fusion Digital Power Designer

The TPSM8D6C24 is supported by Texas Instruments Digital Power Designer. Fusion Digital Power Designer is a graphical user interface (GUI) which can be used to configure and monitor the devices via PMBus using a Texas Instruments USB-to-GPIO adapter.

Click this link to download the Texas Instruments [Fusion Digital Power Designer](#) software package.

##### 8.1.2.2 Custom Design With WEBENCH® Tools

[Click here](#) to create a custom design using the TPSM8D6C24 device with the WEBENCH® Power Designer.

1. Start by entering the input voltage ( $V_{IN}$ ), output voltage ( $V_{OUT}$ ), and output current ( $I_{OUT}$ ) requirements.
2. Optimize the design for key parameters such as efficiency, footprint, and cost using the optimizer dial.
3. Compare the generated design with other possible solutions from Texas Instruments.

The WEBENCH Power Designer provides a customized schematic along with a list of materials with real-time pricing and component availability.

In most cases, these actions are available:

- Run electrical simulations to see important waveforms and circuit performance
- Run thermal simulations to understand board thermal performance
- Export customized schematic and layout into popular CAD formats
- Print PDF reports for the design, and share the design with colleagues

Get more information about WEBENCH tools at [www.ti.com/WEBENCH](http://www.ti.com/WEBENCH).

### 8.2 接收文档更新通知

要接收文档更新通知，请导航至 [ti.com](http://ti.com) 上的器件产品文件夹。点击 [通知](#) 进行注册，即可每周接收产品信息更改摘要。有关更改的详细信息，请查看任何已修订文档中包含的修订历史记录。

### 8.3 支持资源

[TI E2E™ 中文支持论坛](#) 是工程师的重要参考资料，可直接从专家处获得快速、经过验证的解答和设计帮助。搜索现有解答或提出自己的问题，获得所需的快速设计帮助。

链接的内容由各个贡献者“按原样”提供。这些内容并不构成 TI 技术规范，并且不一定反映 TI 的观点；请参阅 TI 的 [使用条款](#)。

### 8.4 Trademarks

TI E2E™ is a trademark of Texas Instruments.

PMBus® is a registered trademark of System Management Interface Forum, Inc..

WEBENCH® is a registered trademark of Texas Instruments.

所有商标均为其各自所有者的财产。

### 8.5 静电放电警告



静电放电 (ESD) 会损坏这个集成电路。德州仪器 (TI) 建议通过适当的预防措施处理所有集成电路。如果不遵守正确的处理和安装程序，可能会损坏集成电路。

ESD 的损坏小至导致微小的性能降级，大至整个器件故障。精密的集成电路可能更容易受到损坏，这是因为非常细微的参数更改都可能会导致器件与其发布的规格不相符。



## 8.6 术语表

[TI 术语表](#)      本术语表列出并解释了术语、首字母缩略词和定义。

## 9 Revision History

注：以前版本的页码可能与当前版本的页码不同

Changes from Revision * (December 2021) to Revision A (November 2023)	Page
• Added pin 55 and pin 56 into <a href="#">表 4-1</a> .....	3
• Changed CMD Code FCh default value from 02D0h to 02C0h in <a href="#">表 6-6</a> .....	34
• Changed the heading from OC_FAULT(A)/ OC_WARN(A) to OC_WARN(A)/OC_FAULT(A) in <a href="#">表 6-11</a> .....	40
• Changed description from Hard coded to 02D0h to Hard coded to 02C0h in <a href="#">表 6-104</a> .....	148
• Changed resistor divider code from 2 or 3 to 6, 7 or open in last sentence of <a href="#">Switching Frequency</a> .....	151
• Changed from $(0.8-0.25) / 0.02 = 27.5$ to $(0.8-0.5) / 0.05 = 6$ in <a href="#">方程式 9</a> .....	152
• Changed from 6.511 mV/A to 6.155 mV/A and changed from 3.255 m $\Omega$ to 3.08 m $\Omega$ in <a href="#">方程式 12</a> .....	153

## 10 Mechanical, Packaging, and Orderable Information

The following pages include mechanical packaging and orderable information. This information is the most current data available for the designated devices. These data is subject to change without notice and revision of this document. For browser-based versions of this data sheet, refer to the left-hand navigation.

**MOW0059A**

**PACKAGE OUTLINE**  
**QFM - 4.4 mm max height**

QUAD FLAT MODULE

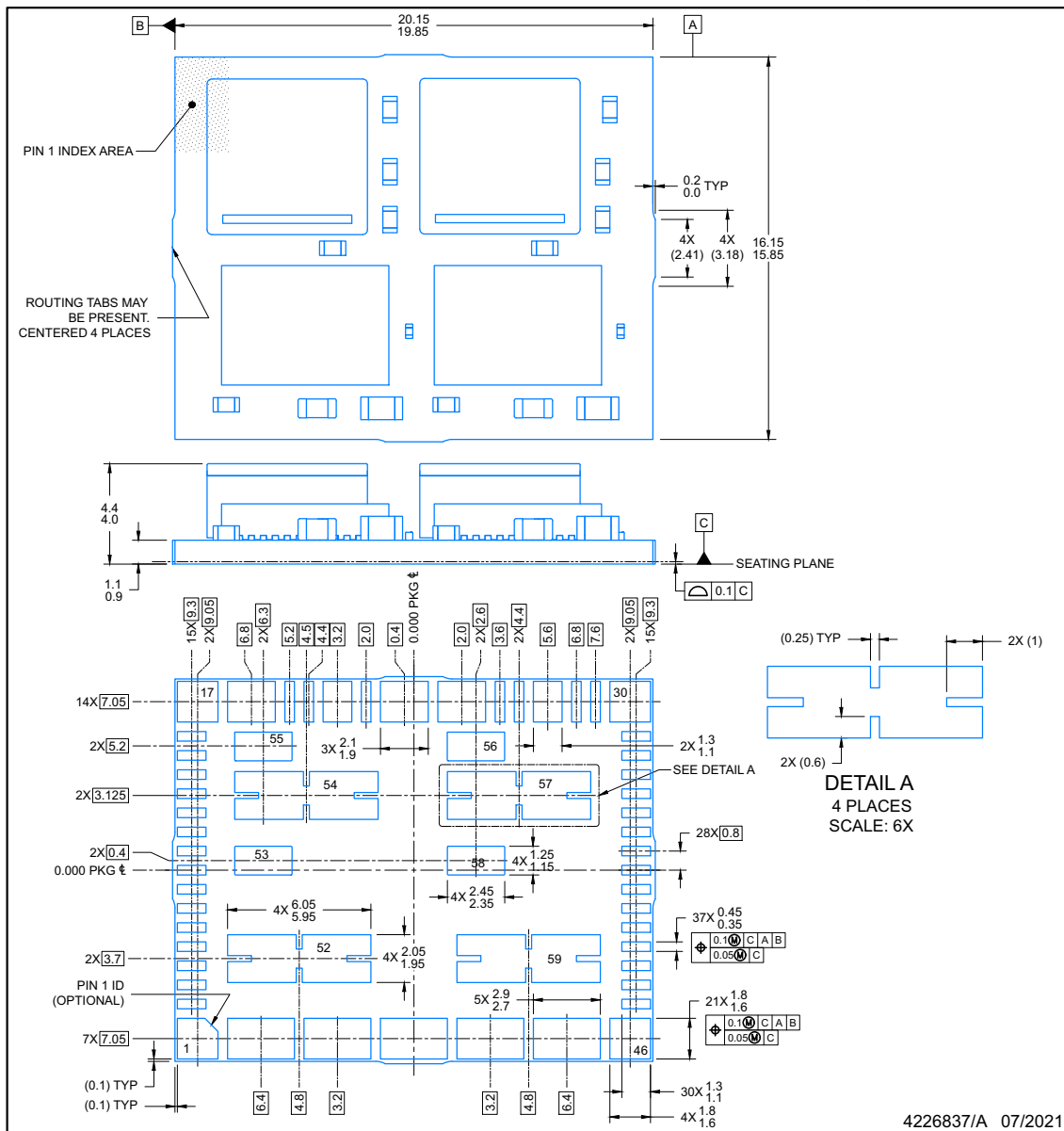

NOTES:

1. All linear dimensions are in millimeters. Any dimensions in parenthesis are for reference only. Dimensioning and tolerancing per ASME Y14.5M.
2. This drawing is subject to change without notice.
3. The package thermal pads must be soldered to the printed circuit board for optimal thermal and mechanical performance.

# EXAMPLE BOARD LAYOUT

QFM - 4.4 mm max height

MOW0059A

QUAD FLAT MODULE

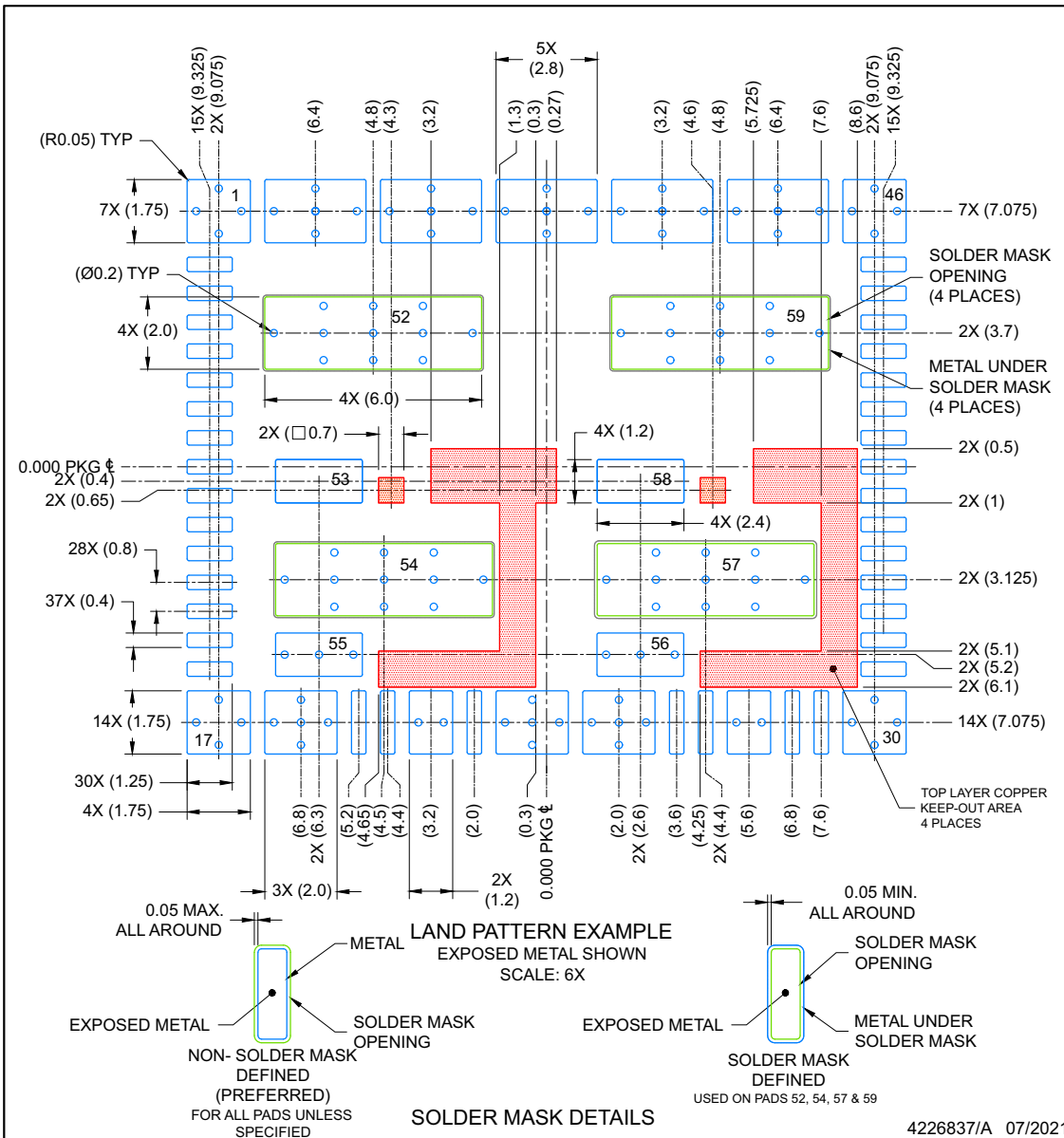

NOTES: (continued)

4. This package is designed to be soldered to thermal pads on the board. For more information, refer to QFN/SON PCB application note in literature No. SLUA271 ([www.ti.com/lit/slua271](http://www.ti.com/lit/slua271)).
5. Vias are optional depending on the application, refer to device data sheet. If any vias are implemented, refer to their locations shown on this view. It is recommended that vias under paste be filled, plugged or tented.

# EXAMPLE BOARD LAYOUT

QFM - 4.4 mm max height

**MOW0059A**

QUAD FLAT MODULE

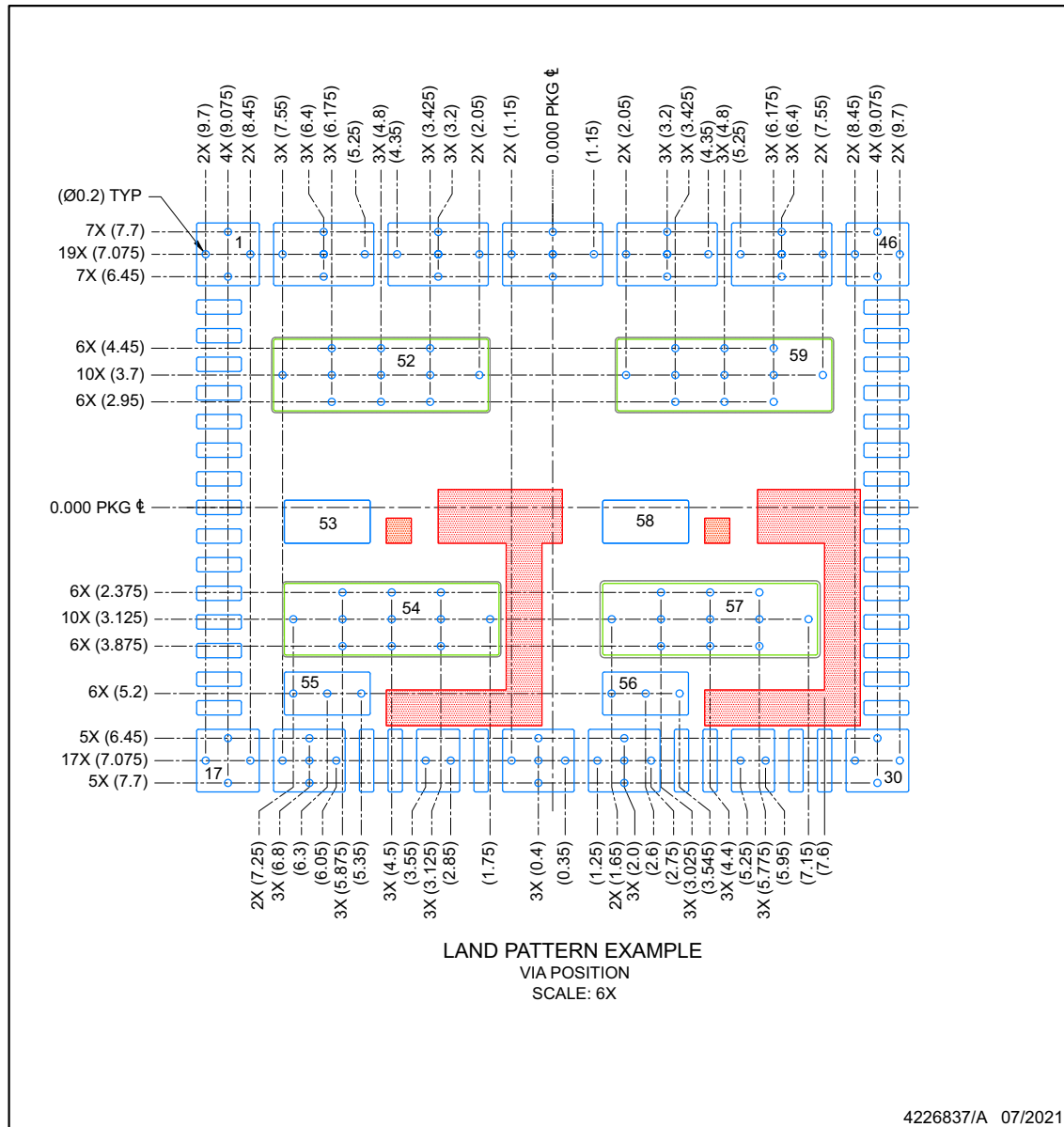

### EXAMPLE STENCIL DESIGN

### MOW0059A

QFM - 4.4 mm max height

QUAD FLAT MODULE

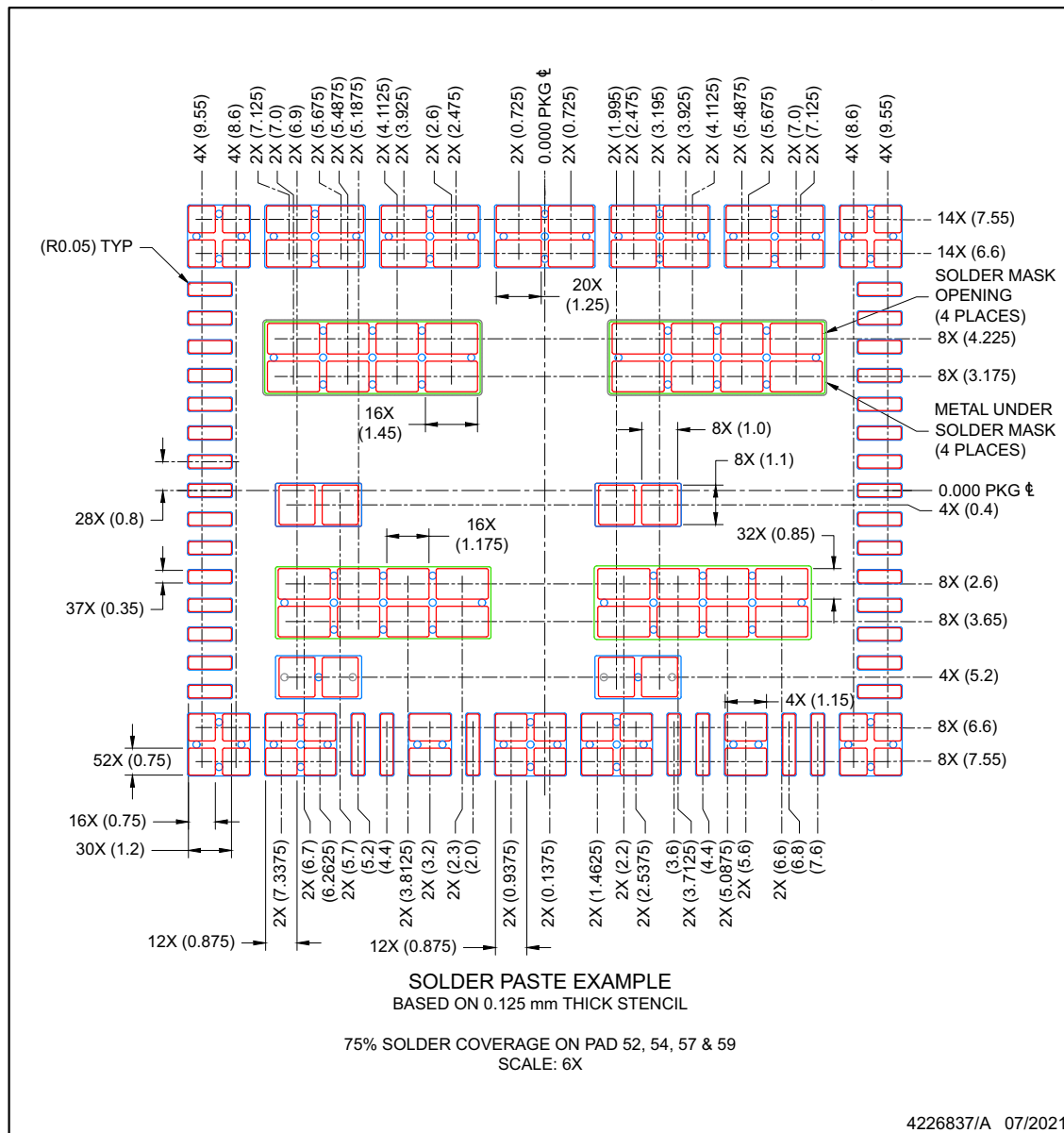

NOTES: (continued)

6. Laser cutting apertures with trapezoidal walls and rounded corners may offer better paste release. IPC-7525 may have alternate design recommendations.
7. Board assembly site may have different recommendations for stencil designs

**PACKAGING INFORMATION**

Orderable Device	Status (1)	Package Type	Package Drawing	Pins	Package Qty	Eco Plan (2)	Lead finish/ Ball material (6)	MSL Peak Temp (3)	Op Temp (°C)	Device Marking (4/5)	Samples
TPSM8D6C24MOWR	ACTIVE	QFM	MOW	59	500	RoHS Exempt & non-Green	NIAU	Level-3-260C-168 HR	-40 to 125	TPSM8D6C24 MOW	Samples

(1) The marketing status values are defined as follows:

**ACTIVE:** Product device recommended for new designs.

**LIFEBUY:** TI has announced that the device will be discontinued, and a lifetime-buy period is in effect.

**NRND:** Not recommended for new designs. Device is in production to support existing customers, but TI does not recommend using this part in a new design.

**PREVIEW:** Device has been announced but is not in production. Samples may or may not be available.

**OBSOLETE:** TI has discontinued the production of the device.

(2) **RoHS:** TI defines "RoHS" to mean semiconductor products that are compliant with the current EU RoHS requirements for all 10 RoHS substances, including the requirement that RoHS substance do not exceed 0.1% by weight in homogeneous materials. Where designed to be soldered at high temperatures, "RoHS" products are suitable for use in specified lead-free processes. TI may reference these types of products as "Pb-Free".

**RoHS Exempt:** TI defines "RoHS Exempt" to mean products that contain lead but are compliant with EU RoHS pursuant to a specific EU RoHS exemption.

**Green:** TI defines "Green" to mean the content of Chlorine (Cl) and Bromine (Br) based flame retardants meet JS709B low halogen requirements of <=1000ppm threshold. Antimony trioxide based flame retardants must also meet the <=1000ppm threshold requirement.

(3) MSL, Peak Temp. - The Moisture Sensitivity Level rating according to the JEDEC industry standard classifications, and peak solder temperature.

(4) There may be additional marking, which relates to the logo, the lot trace code information, or the environmental category on the device.

(5) Multiple Device Markings will be inside parentheses. Only one Device Marking contained in parentheses and separated by a "~" will appear on a device. If a line is indented then it is a continuation of the previous line and the two combined represent the entire Device Marking for that device.

(6) Lead finish/Ball material - Orderable Devices may have multiple material finish options. Finish options are separated by a vertical ruled line. Lead finish/Ball material values may wrap to two lines if the finish value exceeds the maximum column width.

**Important Information and Disclaimer:**The information provided on this page represents TI's knowledge and belief as of the date that it is provided. TI bases its knowledge and belief on information provided by third parties, and makes no representation or warranty as to the accuracy of such information. Efforts are underway to better integrate information from third parties. TI has taken and continues to take reasonable steps to provide representative and accurate information but may not have conducted destructive testing or chemical analysis on incoming materials and chemicals. TI and TI suppliers consider certain information to be proprietary, and thus CAS numbers and other limited information may not be available for release.

In no event shall TI's liability arising out of such information exceed the total purchase price of the TI part(s) at issue in this document sold by TI to Customer on an annual basis.

**TAPE AND REEL INFORMATION**

**QUADRANT ASSIGNMENTS FOR PIN 1 ORIENTATION IN TAPE**

\*All dimensions are nominal

Device	Package Type	Package Drawing	Pins	SPQ	Reel Diameter (mm)	Reel Width W1 (mm)	A0 (mm)	B0 (mm)	K0 (mm)	P1 (mm)	W (mm)	Pin1 Quadrant
TPSM8D6C24MOWR	QFM	MOW	59	500	330.2	32.4	11.4	16.4	4.69	16.0	32.0	Q2



**TAPE AND REEL BOX DIMENSIONS**

\*All dimensions are nominal

Device	Package Type	Package Drawing	Pins	SPQ	Length (mm)	Width (mm)	Height (mm)
TPSM8D6C24MOWR	QFM	MOW	59	500	381.0	381.0	101.6

## 重要声明和免责声明

TI“按原样”提供技术和可靠性数据（包括数据表）、设计资源（包括参考设计）、应用或其他设计建议、网络工具、安全信息和其他资源，不保证没有瑕疵且不做任何明示或暗示的担保，包括但不限于对适销性、某特定用途方面的适用性或不侵犯任何第三方知识产权的暗示担保。

这些资源可供使用 TI 产品进行设计的熟练开发人员使用。您将自行承担以下全部责任：(1) 针对您的应用选择合适的 TI 产品，(2) 设计、验证并测试您的应用，(3) 确保您的应用满足相应标准以及任何其他功能安全、信息安全、监管或其他要求。

这些资源如有变更，恕不另行通知。TI 授权您仅可将这些资源用于研发本资源所述的 TI 产品的应用。严禁对这些资源进行其他复制或展示。您无权使用任何其他 TI 知识产权或任何第三方知识产权。您应全额赔偿因在这些资源的使用中对 TI 及其代表造成的任何索赔、损害、成本、损失和债务，TI 对此概不负责。

TI 提供的产品受 [TI 的销售条款](#) 或 [ti.com](#) 上其他适用条款/TI 产品随附的其他适用条款的约束。TI 提供这些资源并不会扩展或以其他方式更改 TI 针对 TI 产品发布的适用的担保或担保免责声明。

TI 反对并拒绝您可能提出的任何其他或不同的条款。

邮寄地址：Texas Instruments, Post Office Box 655303, Dallas, Texas 75265  
Copyright © 2024，德州仪器 (TI) 公司