

TS5A63157 12Ω SPDT 模拟开关

5V/3.3V 单通道 2:1 多路复用器/多路解复用器

1 特性

- 过冲和下冲电压保护
- 断电模式下的隔离, $V_{+} = 0V$
- 指定的先断后合开关
- 低通态电阻 (12Ω)
- 控制输入可承受 5V 电压
- 低电荷注入
- 出色的通态电阻匹配
- 低总谐波失真 (THD)
- 1.65V 至 5.5V 单电源运行
- 锁断性能超过 100mA (符合 JESD 78, II 类规范的要求)
- ESD 性能测试符合 JESD 22 标准
 - 2000V 人体放电模型 (A114-B, II 类)
 - 1000V 充电器件模型 (C101)

2 应用

- 采样和保持电路
- 电池供电类设备
- 音频和视频信号路由
- 通信电路

3 说明

TS5A63157 是一种单刀双掷 (SPDT) 模拟开关, 设计在 1.65V 至 5.5V 的电压范围内运行。此器件可处理数字信号和模拟信号。高达 V_{+} (峰值) 的信号可在任一方向传输。

TI 已集成了过冲和下冲保护电路。TS5A63157 可检测 I/O 上的过冲和下冲事件, 并且通过防止电压差产生并打开开关来进行响应。

器件信息⁽¹⁾

| 器件型号 | 封装 | 封装尺寸 (标称值) |
|-----------|--------------|-----------------|
| TS5A63157 | SOT-23 (DBV) | 2.90mm x 1.60mm |
| | SC-70 (DCK) | 2.00mm x 1.25mm |

(1) 如需了解所有可用封装, 请参阅数据表末尾的可订购产品附录。

方框图

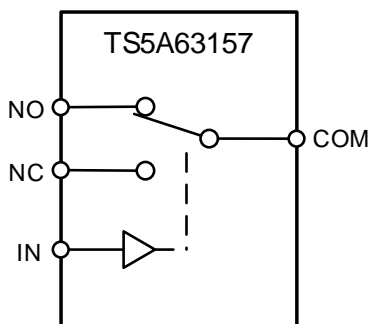

目录

| | | | | | |
|----------|---|-----------|-----------|---|-----------|
| 1 | 特性 | 1 | 8.2 | Functional Block Diagram | 21 |
| 2 | 应用 | 1 | 8.3 | Feature Description | 21 |
| 3 | 说明 | 1 | 8.4 | Device Functional Modes | 21 |
| 4 | 修订历史记录 | 2 | 9 | Application and Implementation | 22 |
| 5 | Pin Configuration and Functions | 3 | 9.1 | Application Information | 22 |
| 6 | Specifications | 4 | 9.2 | Typical Application | 22 |
| 6.1 | Absolute Minimum and Maximum Ratings | 4 | 10 | Power Supply Recommendations | 23 |
| 6.2 | ESD Ratings | 4 | 11 | Layout | 23 |
| 6.3 | Recommended Operating Conditions | 4 | 11.1 | Layout Guidelines | 23 |
| 6.4 | Thermal Information | 4 | 11.2 | Layout Example | 23 |
| 6.5 | Electrical Characteristics for 5-V Supply | 5 | 12 | 器件和文档支持 | 24 |
| 6.6 | Electrical Characteristics for 3.3-V Supply | 7 | 12.1 | 接收文档更新通知 | 24 |
| 6.7 | Electrical Characteristics for 2.5-V Supply | 9 | 12.2 | 社区资源 | 24 |
| 6.8 | Electrical Characteristics for 1.8-V Supply | 11 | 12.3 | 商标 | 24 |
| 6.9 | Typical Characteristics | 13 | 12.4 | 静电放电警告 | 24 |
| 7 | Parameter Measurement Information | 15 | 12.5 | 术语表 | 24 |
| 8 | Detailed Description | 21 | 13 | 机械、封装和可订购信息 | 24 |
| 8.1 | Overview | 21 | | | |

4 修订历史记录

注：之前版本的页码可能与当前版本有所不同。

| Changes from Revision A (August 2009) to Revision B | Page |
|--|------|
| • 添加了器件信息表、ESD 额定值表、建议运行条件表、热性能信息表、特性说明部分、器件功能模式、应用和实施部分、电源建议部分、布局部分、器件和文档支持部分以及机械、封装和可订购信息部分。 | 1 |
| • Deleted the YEP or YZP package option | 3 |
| • Deleted 2 table notes from the <i>Absolute Minimum and Maximum Ratings</i> : "The input and output voltage ratings..." and "This value is limited to 5.5 V maximum." | 4 |

5 Pin Configuration and Functions

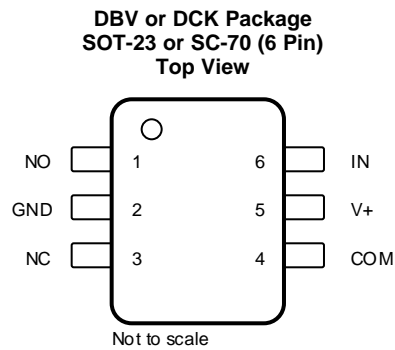

Pin Functions

| PIN | | DESCRIPTION |
|------|-----|---|
| NAME | NO. | |
| NO | 1 | Normally open |
| GND | 2 | Digital ground |
| NC | 3 | Normally closed |
| COM | 4 | Common |
| V+ | 5 | Power supply |
| IN | 6 | Digital control. Logic H = COM to NO, Logic = L COM to NC |

6 Specifications

6.1 Absolute Minimum and Maximum Ratings^{(1) (2)}

over operating free-air temperature range (unless otherwise noted)

| | | MIN | MAX | UNIT |
|-----------------------------------|--|--|-------------|------|
| V_+ | Supply voltage range ⁽³⁾ | -0.5 | 6.5 | V |
| V_{NO} V_{NC} V_{COM} | Analog voltage range ⁽³⁾ | -0.5 | $V_+ + 0.5$ | V |
| I_K | Analog port diode current | $V_{NC}, V_{NO}, V_{COM} < 0$ or $V_{NO}, V_{NC}, V_{COM} > V_+$ | | mA |
| I_{NO} I_{NC} I_{COM} | On-state switch current | $V_{NC}, V_{NO}, V_{COM} = 0$ to V_+ | | mA |
| V_I | Digital input voltage range ⁽³⁾ | -0.5 | 6.5 | V |
| I_{IK} | Digital input clamp current | $V_I < 0$ | | mA |
| I_+ | Continuous current through V_+ | -100 | 100 | mA |
| I_{GND} | Continuous current through GND | -100 | 100 | mA |
| T_{stg} | Storage temperature range | -65 | 150 | °C |

- (1) Stresses above these ratings may cause permanent damage. Exposure to absolute maximum conditions for extended periods may degrade device reliability. These are stress ratings only, and functional operation of the device at these or any other conditions beyond those specified is not implied.
- (2) The algebraic convention, whereby the most negative value is a minimum and the most positive value is a maximum.
- (3) All voltages are with respect to ground, unless otherwise specified.

6.2 ESD Ratings

| | | | VALUE | UNIT |
|-------------|-------------------------|--|-------|------|
| $V_{(ESD)}$ | Electrostatic discharge | Human-body model (HBM), per ANSI/ESDA/JEDEC JS-001 ⁽¹⁾ | ±2000 | V |
| | | Charged-device model (CDM), per JEDEC specification JESD22-C101 or V ANSI/ESDA/JEDEC JS-002 ⁽²⁾ | ±1000 | |

- (1) JEDEC document JEP155 states that 500-V HBM allows safe manufacturing with a standard ESD control process.
- (2) JEDEC document JEP157 states that 250-V CDM allows safe manufacturing with a standard ESD control process.

6.3 Recommended Operating Conditions

over operating free-air temperature range (unless otherwise noted)

| | | MIN | MAX | UNIT |
|-----------------------------|-----------------------------|------|-------|------|
| V_+ | Supply voltage range | 1.65 | 5.5 | V |
| V_{NO} V_{NC} V_{COM} | Analog voltage range | 0 | V_+ | V |
| V_I | Digital input voltage range | 0 | 5.5 | V |

6.4 Thermal Information

| THERMAL METRIC ⁽¹⁾ | | TS5A63157 | | UNIT |
|-------------------------------|--|-----------|--------|------|
| | | DBV | DCK | |
| | | 6 PINS | 6 PINS | |
| $R_{\theta JA}$ | Junction-to-ambient thermal resistance | 209.9 | 298.8 | °C/W |
| $R_{\theta JC(top)}$ | Junction-to-case (top) thermal resistance | 147.1 | 103.9 | °C/W |
| $R_{\theta JB}$ | Junction-to-board thermal resistance | 82.8 | 107.0 | °C/W |
| Ψ_{JT} | Junction-to-top characterization parameter | 65.3 | 2.7 | °C/W |
| Ψ_{JB} | Junction-to-board characterization parameter | 82.5 | 106.2 | °C/W |

- (1) For more information about traditional and new thermal metrics, see the [Semiconductor and IC package thermal metrics application report](#).

6.5 Electrical Characteristics for 5-V Supply

 $V_+ = 4.5\text{ V to }5.5\text{ V}$, $T_A = -40^\circ\text{C to }85^\circ\text{C}$ (unless otherwise noted)

| PARAMETER | SYMBOL | TEST CONDITIONS | T_A | V_+ | MIN | TYP | MAX | UNIT |
|--|----------------------------|---|-------|-------|-----|------------------|------------------|---------------|
| Analog Switch | | | | | | | | |
| Analog signal range | V_{COM}, V_{NO}, V_{NC} | | | | 0 | | V_+ | V |
| Voltage undershoot | V_{IKU} | $0 \geq (I_{NC}, I_{NO}, \text{ or } I_{COM}) \geq -50\text{ mA}$ | | 5.5 V | | | -2 | V |
| Peak ON-state resistance | r_{peak} | $0 \leq (V_{NO} \text{ or } V_{NC}) \leq V_+$, $I_{COM} = -30\text{ mA}$, Switch ON, See Figure 13 | 25°C | 4.5 V | | 4.6 | 11 | Ω |
| | | | Full | | | | | |
| ON-state resistance | r_{on} | $V_{NO} \text{ or } V_{NC} = 0$, $I_{COM} = 30\text{ mA}$ Switch ON, See Figure 13 | 25°C | 4.5 V | | 4 | 6.5 | Ω |
| | | | Full | | | | | |
| | | | 25°C | | | | | |
| | | | Full | | | | | |
| ON-state resistance match between channels | Δr_{on} | $V_{NO} \text{ or } V_{NC} = 3.15\text{ V}$, $I_{COM} = -30\text{ mA}$, Switch ON, See Figure 13 | 25°C | 4.5 V | | 0.1 | 0.14 | Ω |
| | | | Full | | | | | |
| ON-state resistance flatness | $r_{on(flat)}$ | $0 \leq (V_{NO} \text{ or } V_{NC}) \leq V_+$, $I_{COM} = -30\text{ mA}$, Switch ON, See Figure 13 | 25°C | 4.5 V | | 1.5 | 2 | Ω |
| | | | Full | | | | | |
| NC, NO OFF leakage current | $I_{NC(OFF)}, I_{NO(OFF)}$ | $V_{NC} \text{ or } V_{NO} = 0 \text{ to } V_+$, $V_{COM} = V_+ \text{ to } 0$, Switch OFF, See Figure 14 | 25°C | 5.5 V | | 0.001 | 0.03 | μA |
| | | | Full | | | | | |
| COM OFF leakage current | $I_{COM(PWROFF)}$ | $V_{COM} = 0 \text{ to } 5.5\text{ V}$, $V_{NC} \text{ or } V_{NO} = 5.5\text{ V to } 0$, Switch ON, See Figure 14 | 25°C | 0 | | 0.2 | 1 | μA |
| | | | Full | | | | | |
| NC, NO ON leakage current | $I_{NC(ON)}, I_{NO(ON)}$ | $V_{NC} \text{ or } V_{NO} = 0 \text{ to } V_+$, $V_{COM} = \text{Open}$, Switch ON, See Figure 15 | 25°C | 5.5 V | | 0.001 | 0.01 | μA |
| | | | Full | | | | | |
| COM ON leakage current | $I_{COM(ON)}$ | $V_{NC} \text{ or } V_{NO} = \text{Open}$, $V_{COM} = 0 \text{ to } V_+$, Switch ON, See Figure 15 | 25°C | 5.5 V | | 0.003 | 0.03 | μA |
| | | | Full | | | | | |
| Digital Control Input (IN) | | | | | | | | |
| Input logic high | V_{IH} | | Full | | | $V_+ \times 0.7$ | 5.5 | V |
| Input logic low | V_{IL} | | Full | | | 0 | $V_+ \times 0.3$ | V |
| Input leakage current | I_{IH}, I_{IL} | $V_I = 5.5\text{ V or } 0$ | 25°C | 5.5 V | | 0.05 | 0.1 | μA |
| | | | Full | | | | | |

Electrical Characteristics for 5-V Supply (continued)

$V_+ = 4.5\text{ V to }5.5\text{ V}$, $T_A = -40^\circ\text{C to }85^\circ\text{C}$ (unless otherwise noted)

| PARAMETER | SYMBOL | TEST CONDITIONS | T_A | V_+ | MIN | TYP | MAX | UNIT |
|----------------------------------|----------------------------------|---|-------|-------------------|------|----------------|-----|---------------|
| Dynamic | | | | | | | | |
| Turn-on time | t_{ON} | $V_{COM} = V_+$ or GND, $R_L = 500\ \Omega$, $C_L = 50\text{ pF}$, See Figure 17 | 25°C | 5 V | 2 | 3.4 | 5 | ns |
| | | | Full | 4.5 V to 5.5 V | 2 | | 5.5 | |
| Turn-off time | t_{OFF} | $V_{COM} = V_+$ or GND, $R_L = 500\ \Omega$, $C_L = 50\text{ pF}$, See Figure 17 | 25°C | 5 V | 1 | 2.8 | 3.4 | ns |
| | | | Full | 4.5 V to 5.5 V | 1 | | 3.8 | |
| Output voltage during undershoot | V_{OUTU} | See Figure 18 | | | 2.5 | $V_{OH} - 0.3$ | | V |
| Output voltage during overshoot | V_{OUTO} | See Figure 18 | | | | $V_{OL} + 0.3$ | 2 | V |
| Break-before-make time | t_{BBM} | $V_{NC} = V_{NO} = V_+/2$, $R_L = 50\ \Omega$, $C_L = 50\text{ pF}$, See Figure 19 | 25°C | 5 V | 0.5 | 5 | 12 | ns |
| | | | Full | 4.5 V to 5.5 V | 0.5 | | 14 | |
| Charge injection | Q_C | $V_{GEN} = 0$, $R_{GEN} = 0$, $C_L = 0.1\text{ nF}$, See Figure 23 | 25°C | 5 V | | -21 | | pC |
| NC, NO OFF capacitance | $C_{NC(OFF)}$, $C_{NO(OFF)}$ | V_{NC} or $V_{NO} = V_+$ or GND, Switch OFF, See Figure 16 | 25°C | 5 V | | 5 | | pF |
| NC, NO ON capacitance | $C_{NC(ON)}$, $C_{NO(ON)}$ | V_{NC} or $V_{NO} = V_+$ or GND, Switch ON, See Figure 16 | 25°C | 5 V | | 14.5 | | pF |
| COM ON capacitance | $C_{COM(ON)}$ | $V_{COM} = V_+$ or GND, Switch ON, See Figure 16 | 25°C | 5 V | | 14.5 | | pF |
| Digital input capacitance | C_I | $V_I = V_+$ or GND, See Figure 16 | 25°C | 5 V | | 2.5 | | pF |
| Bandwidth | BW | $R_L = 50\ \Omega$, Switch ON, See Figure 20 | 25°C | 5 V | | 371 | | MHz |
| OFF isolation | O_{ISO} | $R_L = 50\ \Omega$, $f = 10\text{ MHz}$, Switch OFF, See Figure 21 | 25°C | 5 V | | -61 | | dB |
| Crosstalk | X_{TALK} | $R_L = 50\ \Omega$, $f = 10\text{ MHz}$, Switch ON, See Figure 22 | 25°C | 5 V | | -61 | | dB |
| Total harmonic distortion | THD | $R_L = 600\ \Omega$, $C_L = 50\text{ pF}$, $f = 20\text{ Hz to }20\text{ kHz}$, See Figure 24 | 25°C | 5 V | | 0.06% | | |
| Supply | | | | | | | | |
| Positive supply current | I_+ | $V_I = V_+$ or GND, Switch ON or OFF | 25°C | 5.5 V | 0.01 | 0.1 | | μA |
| | | | Full | | | 0.75 | | |

6.6 Electrical Characteristics for 3.3-V Supply

 $V_+ = 3\text{ V to }3.6\text{ V}$, $T_A = -40^\circ\text{C to }85^\circ\text{C}$ (unless otherwise noted)

| PARAMETER | SYMBOL | TEST CONDITIONS | T_A | V_+ | MIN | TYP | MAX | UNIT |
|--|--------------------------------|--|-------|-------|------------------|-------|------------------|---------------|
| Analog Switch | | | | | | | | |
| Analog signal range | V_{COM}, V_{NO}, V_{NC} | | | | 0 | | V_+ | V |
| Voltage undershoot | V_{IKU} | $0 \geq (I_{NC}, I_{NO}, \text{ or } I_{COM}) \geq -50\text{ mA}$ | | 3.6 V | | | | V |
| Peak ON-state resistance | r_{peak} | $0 \leq (V_{NO} \text{ or } V_{NC}) \leq V_+$, $I_{COM} = -24\text{ mA}$, Switch ON, See Figure 13 | 25°C | 3 V | | 6.4 | 14 | Ω |
| | | | Full | | | 18 | | |
| ON-state resistance | r_{on} | $V_{NO} \text{ or } V_{NC} = 0$, $I_{COM} = 24\text{ mA}$ | 25°C | 3 V | | 4.8 | 8 | Ω |
| | | | Full | | | 10 | | |
| | | 25°C | 6.3 | | | 12 | | |
| | | Full | 15 | | | | | |
| ON-state resistance match between channels | Δr_{on} | $V_{NO} \text{ or } V_{NC} = 2.1\text{ V}$, $I_{COM} = -24\text{ mA}$, Switch ON, See Figure 13 | 25°C | 3 V | | 0.1 | 0.2 | Ω |
| | | | Full | | | 0.2 | | |
| ON-state resistance flatness | $r_{on(flat)}$ | $0 \leq (V_{NO} \text{ or } V_{NC}) \leq V_+$, $I_{COM} = -24\text{ mA}$, Switch ON, See Figure 13 | 25°C | 3 V | | 2.8 | 4 | Ω |
| | | | Full | | | 7 | | |
| NC, NO OFF leakage current | $I_{NC(OFF)}, I_{NO(OFF)}$ | $V_{NC} \text{ or } V_{NO} = 0 \text{ to } V_+$, $V_{COM} = V_+ \text{ to } 0$, Switch OFF, See Figure 14 | 25°C | 3.6 V | | 0 | 0.03 | μA |
| | | | Full | | | 0.05 | | |
| | $I_{NC(PWROFF)}, I_{NOPWROFF}$ | $V_{NC} \text{ or } V_{NO} = 0 \text{ to } 3.6\text{ V}$, $V_{COM} = 3.6\text{ V to } 0$, Switch OFF, See Figure 14 | 25°C | 0 | | 0.15 | 0.50 | |
| | | | Full | | | 2 | | |
| COM OFF leakage current | $I_{COM(PWROFF)}$ | $V_{COM} = 0 \text{ to } 3.6\text{ V}$, $V_{NC} \text{ or } V_{NO} = 3.6\text{ V to } 0$, Switch ON, See Figure 14 | 25°C | 0 | | 0.2 | 0.5 | μA |
| | | | Full | | | 5 | | |
| NC, NO ON leakage current | $I_{NC(ON)}, I_{NO(ON)}$ | $V_{NC} \text{ or } V_{NO} = 0 \text{ to } V_+$, $V_{COM} = \text{Open}$, Switch ON, See Figure 15 | 25°C | 3.6 V | | 0.001 | 0.01 | μA |
| | | | Full | | | 0.02 | | |
| COM ON leakage current | $I_{COM(ON)}$ | $V_{NC} \text{ or } V_{NO} = \text{Open}$, $V_{COM} = 0 \text{ to } V_+$, Switch ON, See Figure 15 | 25°C | 3.6 V | | 0.003 | 0.03 | μA |
| | | | Full | | | 0.05 | | |
| Digital Control Input (IN) | | | | | | | | |
| Input logic high | V_{IH} | | Full | | $V_+ \times 0.7$ | | 5.5 | V |
| Input logic low | V_{IL} | | Full | | 0 | | $V_+ \times 0.3$ | V |
| Input leakage current | I_{IH}, I_{IL} | $V_I = 5.5\text{ V or } 0$ | 25°C | 3.6 V | | 0.005 | 0.01 | μA |
| | | | Full | | | 0.02 | | |

Electrical Characteristics for 3.3-V Supply (continued)

$V_+ = 3\text{ V to }3.6\text{ V}$, $T_A = -40^\circ\text{C to }85^\circ\text{C}$ (unless otherwise noted)

| PARAMETER | SYMBOL | TEST CONDITIONS | T_A | V_+ | MIN | TYP | MAX | UNIT | |
|----------------------------------|----------------------------------|---|--|-------|-----------------|------------------|-------|---------------|----|
| Dynamic | | | | | | | | | |
| Turn-on time | t_{ON} | $V_{COM} = V_+$ or GND, $R_L = 500\ \Omega$, | $C_L = 50\text{ pF}$, See Figure 17 | 25°C | 3.3 V | 2 | 4.3 | 6.6 | ns |
| | | | | Full | 3 V to 3.6 V | 2 | | 7 | |
| Turn-off time | t_{OFF} | $V_{COM} = V_+$ or GND, $R_L = 500\ \Omega$, | $C_L = 50\text{ pF}$, See Figure 17 | 25°C | 3.3 V | 1 | 3.3 | 6.3 | ns |
| | | | | Full | 3 V to 3.6 V | 1 | | 7 | |
| Output voltage during undershoot | V_{OUTU} | See Figure 18 | | | 2.5 | V_{OH} –0.3 | | V | |
| Output voltage during overshoot | V_{OUTO} | See Figure 18 | | | | V_{OL} +0.3 | 2 | V | |
| Break-before-make time | t_{BBM} | $V_{NC} = V_{NO} = V_+/2$, $R_L = 50\ \Omega$, | $C_L = 50\text{ pF}$, See Figure 19 | 25°C | 3.3 V | 0.5 | 7 | 17 | ns |
| | | | | Full | 3 V to 3.6 V | 0.5 | | 19.5 | |
| Charge injection | Q_C | $V_{GEN} = 0$, $R_{GEN} = 0$, | $C_L = 0.1\text{ nF}$, See Figure 23 | 25°C | 3.3 V | | –11.5 | pC | |
| NC, NO OFF capacitance | $C_{NC(OFF)}$, $C_{NO(OFF)}$ | V_{NC} or $V_{NO} = V_+$ or GND, Switch OFF, | See Figure 16 | 25°C | 3.3 V | | 5 | pF | |
| NC, NO ON capacitance | $C_{NC(ON)}$, $C_{NO(ON)}$ | V_{NC} or $V_{NO} = V_+$ or GND, Switch ON, | See Figure 16 | 25°C | 3.3 V | | 15 | pF | |
| COM ON capacitance | $C_{COM(ON)}$ | $V_{COM} = V_+$ or GND, Switch ON, | See Figure 16 | 25°C | 3.3 V | | 15 | pF | |
| Digital input capacitance | C_I | $V_I = V_+$ or GND, | See Figure 16 | 25°C | 3.3 V | | 2.5 | pF | |
| Bandwidth | BW | $R_L = 50\ \Omega$, Switch ON, | See Figure 20 | 25°C | 3.3 V | | 370 | MHz | |
| OFF isolation | O_{ISO} | $R_L = 50\ \Omega$, $f = 10\text{ MHz}$, | Switch OFF, See Figure 21 | 25°C | 3.3 V | | –60 | dB | |
| Crosstalk | X_{TALK} | $R_L = 50\ \Omega$, $f = 10\text{ MHz}$, | Switch ON, See Figure 22 | 25°C | 3.3 V | | –60 | dB | |
| Total harmonic distortion | THD | $R_L = 600\ \Omega$, $C_L = 50\text{ pF}$, | $f = 20\text{ Hz to }20\text{ kHz}$, See Figure 24 | 25°C | 3.3 V | | 0.1% | | |
| Supply | | | | | | | | | |
| Positive supply current | I_+ | $V_I = V_+$ or GND, | Switch ON or OFF | 25°C | 3.6 V | 0.05 | 0.1 | μA | |
| | | | | Full | | | 0.6 | | |

6.7 Electrical Characteristics for 2.5-V Supply

 $V_+ = 2.3 \text{ V to } 2.7 \text{ V}$, $T_A = -40^\circ\text{C to } 85^\circ\text{C}$ (unless otherwise noted)

| PARAMETER | SYMBOL | TEST CONDITIONS | T_A | V_+ | MIN | TYP | MAX | UNIT |
|--|----------------------------------|--|------------------------------|-------|-------------------|------------|-------------------|---------------|
| Analog Switch | | | | | | | | |
| Analog signal range | V_{COM}, V_{NO}, V_{NC} | | | | 0 | | V_+ | V |
| Voltage undershoot | V_{IKU} | $0 \text{ mA} \geq (I_{NC}, I_{NO}, \text{ or } I_{COM}) \geq -50 \text{ mA}$ | | 2.7 V | | | | V |
| Peak ON-state resistance | r_{peak} | $0 \leq (V_{NO} \text{ or } V_{NC}) \leq V_+$, $I_{COM} = -8 \text{ mA}$, Switch ON, See Figure 13 | 25°C Full | 2.3 V | | 9.2 30 | | Ω |
| ON-state resistance | r_{on} | $V_{NO} \text{ or } V_{NC} = 0$, $I_{COM} = 8 \text{ mA}$ $V_{NO} \text{ or } V_{NC} = 2.3 \text{ V}$, $I_{COM} = -8 \text{ mA}$ Switch ON, See Figure 13 | 25°C Full 25°C Full | 2.3 V | | 5.4 8.6 | 8.5 15.5 | Ω |
| ON-state resistance match between channels | Δr_{on} | $V_{NO} \text{ or } V_{NC} = 1.6 \text{ V}$, $I_{COM} = -8 \text{ mA}$, Switch ON, See Figure 13 | 25°C Full | 2.3 V | | 0.05 | 0.3 0.5 | Ω |
| ON-state resistance flatness | $r_{on(Flat)}$ | $0 \leq (V_{NO} \text{ or } V_{NC}) \leq V_+$, $I_{COM} = -8 \text{ mA}$, Switch ON, See Figure 13 | 25°C Full | 2.3 V | | 5 | 9 15 | Ω |
| NC, NO OFF leakage current | $I_{NC(OFF)}, I_{NO(OFF)}$ | $V_{NC} \text{ or } V_{NO} = 0 \text{ to } V_+$, $V_{COM} = V_+ \text{ to } 0$, Switch OFF, See Figure 14 | 25°C Full | 2.7 V | | 0 | 0.03 0.05 | μA |
| | $I_{NC(PWROFF)}, I_{NO(PWROFF)}$ | $V_{NC} \text{ or } V_{NO} = 0 \text{ to } 2.7 \text{ V}$, $V_{COM} = 2.7 \text{ V to } 0$, Switch OFF, See Figure 14 | 25°C Full | 0 | | 0.15 | 0.50 0.75 | |
| COM OFF leakage current | $I_{COM(PWROFF)}$ | $V_{COM} = 0 \text{ to } 2.7 \text{ V}$, $V_{NC} \text{ or } V_{NO} = 2.7 \text{ V to } 0$, Switch ON, See Figure 14 | 25°C Full | 0 | | 0.2 | 0.5 1 | μA |
| NC, NO ON leakage current | $I_{NC(ON)}, I_{NO(ON)}$ | $V_{NC} \text{ or } V_{NO} = 0 \text{ to } V_+$, $V_{COM} = \text{Open}$, Switch ON, See Figure 15 | 25°C Full | 2.7 V | | 0.001 | 0.01 0.02 | μA |
| COM ON leakage current | $I_{COM(ON)}$ | $V_{NC} \text{ or } V_{NO} = \text{Open}$, $V_{COM} = 0 \text{ to } V_+$, Switch ON, See Figure 15 | 25°C Full | 2.7 V | | 0.003 | 0.03 0.05 | μA |
| Digital Control Input (IN) | | | | | | | | |
| Input logic high | V_{IH} | | Full | | $V_+ \times 0.75$ | | 5.5 | V |
| Input logic low | V_{IL} | | Full | | 0 | | $V_+ \times 0.25$ | V |
| Input leakage current | I_{IH}, I_{IL} | $V_I = 5.5 \text{ V or } 0$ | 25°C | 2.7 V | | 0.005 | 0.01 | μA |
| | | | Full | | | | | |

Electrical Characteristics for 2.5-V Supply (continued)

$V_+ = 2.3 \text{ V to } 2.7 \text{ V}$, $T_A = -40^\circ\text{C to } 85^\circ\text{C}$ (unless otherwise noted)

| PARAMETER | SYMBOL | TEST CONDITIONS | T_A | V_+ | MIN | TYP | MAX | UNIT | |
|----------------------------------|----------------------------------|--|---|-------|-------------------|------------------|-------|------|----|
| Dynamic | | | | | | | | | |
| Turn-on time | t_{ON} | $V_{COM} = V_+$ or GND, $R_L = 500 \Omega$, | $C_L = 50 \text{ pF}$, See Figure 17 | 25°C | 2.5 V | 3 | 5.8 | 9.6 | ns |
| | | | | Full | 2.3 V to 2.7 V | 3 | | 12 | |
| Turn-off time | t_{OFF} | $V_{COM} = V_+$ or GND, $R_L = 500 \Omega$, | $C_L = 50 \text{ pF}$, See Figure 17 | 25°C | 2.5 V | 1.5 | 4.5 | 7.3 | ns |
| | | | | Full | 2.3 V to 2.7 V | 1.5 | | 7.5 | |
| Output voltage during undershoot | V_{OUTU} | See Figure 18 | | | 2.5 | V_{OH} –0.3 | | V | |
| Output voltage during overshoot | V_{OUTO} | See Figure 18 | | | | V_{OL} +0.3 | 2 | V | |
| Break-before-make time | t_{BBM} | $V_{NC} = V_{NO} = V_+/2$, $R_L = 50 \Omega$, | $C_L = 50 \text{ pF}$, See Figure 19 | 25°C | 2.5 V | 0.5 | 10 | 25 | ns |
| | | | | Full | 2.3 V to 2.7 V | 0.5 | | 28.5 | |
| Charge injection | Q_C | $V_{GEN} = 0$, $R_{GEN} = 0$, | $C_L = 0.1 \text{ nF}$, See Figure 23 | 25°C | 2.5 V | | –8 | pC | |
| NC, NO OFF capacitance | $C_{NC(OFF)}$, $C_{NO(OFF)}$ | V_{NC} or $V_{NO} = V_+$ or GND, Switch OFF, | See Figure 16 | 25°C | 2.5 V | | 5 | pF | |
| NC, NO ON capacitance | $C_{NC(ON)}$, $C_{NO(ON)}$ | V_{NC} or $V_{NO} = V_+$ or GND, Switch ON, | See Figure 16 | 25°C | 2.5 V | | 15 | pF | |
| COM ON capacitance | $C_{COM(ON)}$ | $V_{COM} = V_+$ or GND, Switch ON, | See Figure 16 | 25°C | 2.5 V | | 15 | pF | |
| Digital input capacitance | C_I | $V_I = V_+$ or GND, | See Figure 16 | 25°C | 2.5 V | | 2.5 | pF | |
| Bandwidth | BW | $R_L = 50 \Omega$, Switch ON, | See Figure 20 | 25°C | 2.5 V | | 367 | MHz | |
| OFF isolation | O_{ISO} | $R_L = 50 \Omega$, $f = 10 \text{ MHz}$, | Switch OFF, See Figure 21 | 25°C | 2.5 V | | –60 | dB | |
| Crosstalk | X_{TALK} | $R_L = 50 \Omega$, $f = 10 \text{ MHz}$, | Switch ON, See Figure 22 | 25°C | 2.5 V | | –60 | dB | |
| Total harmonic distortion | THD | $R_L = 600 \Omega$, $C_L = 50 \text{ pF}$, | $f = 20 \text{ Hz to } 20 \text{ kHz}$, See Figure 24 | 25°C | 2.5 V | | 0.15% | | |
| Supply | | | | | | | | | |
| Positive supply current | I_+ | $V_I = V_+$ or GND, | Switch ON or OFF | 25°C | 2.7 V | 0.05 | 0.1 | nA | |
| | | | | Full | | | 0.5 | | |

6.8 Electrical Characteristics for 1.8-V Supply

 $V_+ = 1.65\text{ V to }1.95\text{ V}$, $T_A = -40^\circ\text{C to }85^\circ\text{C}$ (unless otherwise noted)

| PARAMETER | SYMBOL | TEST CONDITIONS | T_A | V_+ | MIN | TYP | MAX | UNIT |
|--|--------------------------------|--|--|--------|-------------------|-------|-------------------|---------------|
| Analog Switch | | | | | | | | |
| Analog signal range | V_{COM}, V_{NO}, V_{NC} | | | | 0 | | V_+ | V |
| Voltage undershoot | V_{IKU} | $0 \geq (I_{NC}, I_{NO}, \text{ or } I_{COM}) \geq -50\text{ mA}$ | | 1.95 V | | | | V |
| Peak ON-state resistance | r_{peak} | $0 \leq (V_{NO} \text{ or } V_{NC}) \leq V_+$, $I_{COM} = -4\text{ mA}$, | Switch ON, See Figure 13 | 25°C | 1.65 V | 13.8 | 60 | Ω |
| | | | | Full | | | 120 | |
| ON-state resistance | r_{on} | $V_{NO} \text{ or } V_{NC} = 0$, $I_{COM} = 4\text{ mA}$ | Switch ON, See Figure 13 | 25°C | 1.65 V | 5.9 | 15 | Ω |
| | | | | Full | | | 15 | |
| | | 25°C | | | | 12.8 | 40 | |
| | | Full | | | | 45 | | |
| ON-state resistance match between channels | Δr_{on} | $V_{NO} \text{ or } V_{NC} = 1.15\text{ V}$, $I_{COM} = -4\text{ mA}$, | Switch ON, See Figure 13 | 25°C | 1.65 V | 0.1 | 0.5 | Ω |
| | | | | Full | | | 0.8 | |
| ON-state resistance flatness | $r_{on(Flat)}$ | $0 \leq (V_{NO} \text{ or } V_{NC}) \leq V_+$, $I_{COM} = -4\text{ mA}$, | Switch ON, See Figure 13 | 25°C | 1.65 V | 26.5 | 60 | Ω |
| | | | | Full | | | 80 | |
| NC, NO OFF leakage current | $I_{NC(OFF)}, I_{NO(OFF)}$ | $V_{NC} \text{ or } V_{NO} = 0 \text{ to } V_+$, $V_{COM} = V_+ \text{ to } 0$, | Switch OFF, See Figure 14 | 25°C | 1.95 V | 0 | 0.03 | μA |
| | | | | Full | | | 0.05 | |
| | $I_{NC(PWROFF)}, I_{NOPWROFF}$ | $V_{NC} \text{ or } V_{NO} = 0 \text{ to } 1.95\text{ V}$, $V_{COM} = 1.95\text{ V to } 0$, | Switch OFF, See Figure 14 | 25°C | 0 | 0.15 | 0.50 | |
| | | | | Full | | | 0.75 | |
| COM OFF leakage current | $I_{COM(PWROFF)}$ | $V_{COM} = 0 \text{ to } 1.95\text{ V}$, $V_{NC} \text{ or } V_{NO} = 1.95\text{ V to } 0$, | Switch ON, See Figure 14 | 25°C | 0 | 0.2 | 0.5 | μA |
| | | | | Full | | | 1 | |
| NC, NO ON leakage current | $I_{NC(ON)}, I_{NO(ON)}$ | $V_{NC} \text{ or } V_{NO} = 0 \text{ to } V_+$, $V_{COM} = \text{Open}$, | Switch ON, See Figure 15 | 25°C | 1.95 V | 0.001 | 0.01 | μA |
| | | | | Full | | | 0.02 | |
| COM ON leakage current | $I_{COM(ON)}$ | $V_{NC} \text{ or } V_{NO} = \text{Open}$, $V_{COM} = 0 \text{ to } V_+$, | Switch ON, See Figure 15 | 25°C | 1.95 V | 0.003 | 0.03 | μA |
| | | | | Full | | | 0.05 | |
| Digital Control Input (IN) | | | | | | | | |
| Input logic high | V_{IH} | | Full | | $V_+ \times 0.75$ | | 5.5 | V |
| Input logic low | V_{IL} | | Full | | 0 | | $V_+ \times 0.25$ | V |
| Input leakage current | I_{IH}, I_{IL} | $V_I = 5.5\text{ V or } 0$ | 25°C | 1.95 V | 0.005 | 0.01 | μA | |
| | | | Full | | | 0.02 | | |

Electrical Characteristics for 1.8-V Supply (continued)

$V_+ = 1.65\text{ V to }1.95\text{ V}$, $T_A = -40^\circ\text{C to }85^\circ\text{C}$ (unless otherwise noted)

| PARAMETER | SYMBOL | TEST CONDITIONS | T_A | V_+ | MIN | TYP | MAX | UNIT | |
|----------------------------------|----------------------------------|---|--|-------|---------------------|------------------|------|---------------|----|
| Dynamic | | | | | | | | | |
| Turn-on time | t_{ON} | $V_{COM} = V_+$ or GND, $R_L = 500\ \Omega$, | $C_L = 50\text{ pF}$, See Figure 17 | 25°C | 1.8 V | 9.5 | 23 | ns | |
| | | | | Full | 1.65 V to 1.95 V | | 24 | | |
| Turn-off time | t_{OFF} | $V_{COM} = V_+$ or GND, $R_L = 500\ \Omega$, | $C_L = 50\text{ pF}$, See Figure 17 | 25°C | 1.8 V | 5.9 | 10 | ns | |
| | | | | Full | 1.65 V to 1.95 V | | 12 | | |
| Output voltage during undershoot | V_{OUTU} | See Figure 18 | | | 2.5 | V_{OH} –0.3 | | V | |
| Output voltage during overshoot | V_{OUTO} | See Figure 18 | | | | V_{OL} +0.3 | 2 | V | |
| Break-before-make time | t_{BBM} | $V_{NC} = V_{NO} = V_+/2$, $R_L = 50\ \Omega$, | $C_L = 50\text{ pF}$, See Figure 19 | 25°C | 1.8 V | 0.5 | 18 | 50 | ns |
| | | | | Full | 1.65 V to 1.95 V | 0.5 | | 55 | |
| Charge injection | Q_C | $V_{GEN} = 0$, $R_{GEN} = 0$, | $C_L = 0.1\text{ nF}$, See Figure 23 | 25°C | 1.8 V | | –5 | pC | |
| NC, NO OFF capacitance | $C_{NC(OFF)}$, $C_{NO(OFF)}$ | V_{NC} or $V_{NO} = V_+$ or GND, Switch OFF, | See Figure 16 | 25°C | 1.8 V | | 5.5 | pF | |
| NC, NO ON capacitance | $C_{NC(ON)}$, $C_{NO(ON)}$ | V_{NC} or $V_{NO} = V_+$ or GND, Switch ON, | See Figure 16 | 25°C | 1.8 V | | 15.5 | pF | |
| COM ON capacitance | $C_{COM(ON)}$ | $V_{COM} = V_+$ or GND, Switch ON, | See Figure 16 | 25°C | 1.8 V | | 15.5 | pF | |
| Digital input capacitance | C_I | $V_I = V_+$ or GND, | See Figure 16 | 25°C | 1.8 V | | 2.5 | pF | |
| Bandwidth | BW | $R_L = 50\ \Omega$, Switch ON, | See Figure 20 | 25°C | 1.8 V | | 369 | MHz | |
| OFF isolation | O_{ISO} | $R_L = 50\ \Omega$, $f = 10\text{ MHz}$, | Switch OFF, See Figure 21 | 25°C | 1.8 V | | –60 | dB | |
| Crosstalk | X_{TALK} | $R_L = 50\ \Omega$, $f = 10\text{ MHz}$, | Switch ON, See Figure 22 | 25°C | 1.8 V | | –60 | dB | |
| Total harmonic distortion | THD | $R_L = 600\ \Omega$, $C_L = 50\text{ pF}$, | $f = 20\text{ Hz to }20\text{ kHz}$, See Figure 24 | 25°C | 1.8 V | | 0.4% | | |
| Supply | | | | | | | | | |
| Positive supply current | I_+ | $V_I = V_+$ or GND, | Switch ON or OFF | 25°C | 1.95 V | 0.05 | 0.06 | μA | |
| | | | | Full | | | 0.3 | | |

6.9 Typical Characteristics

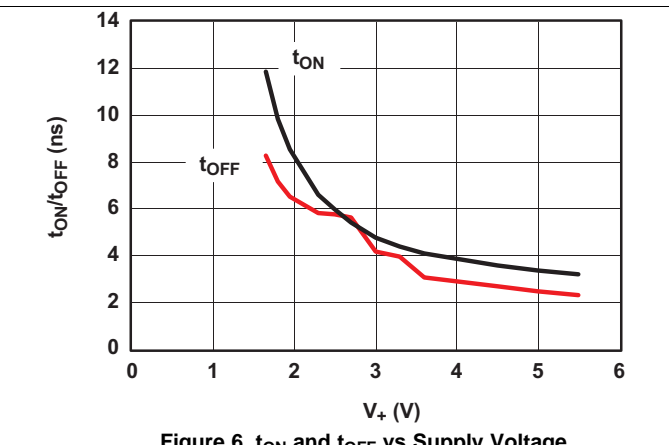
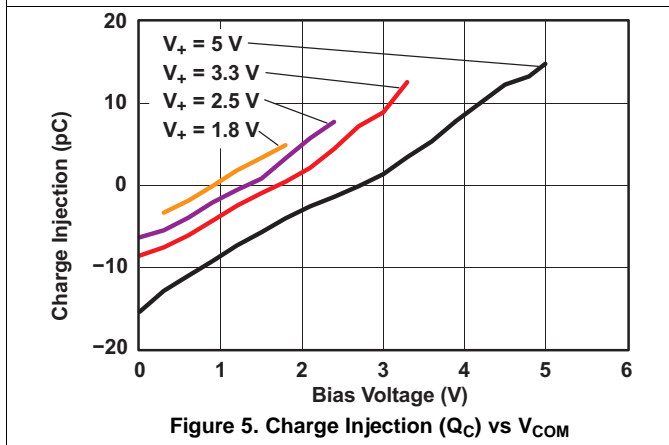
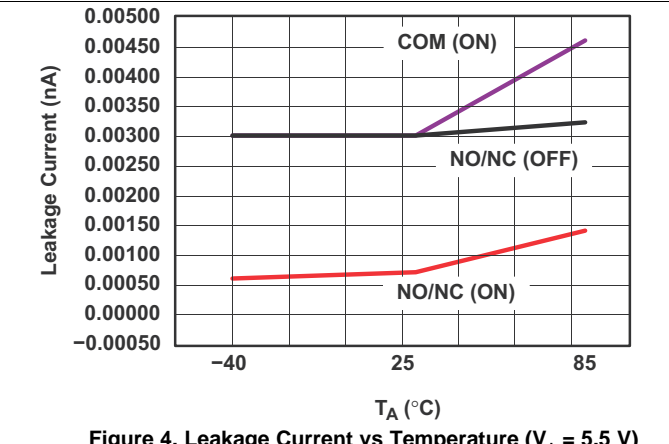
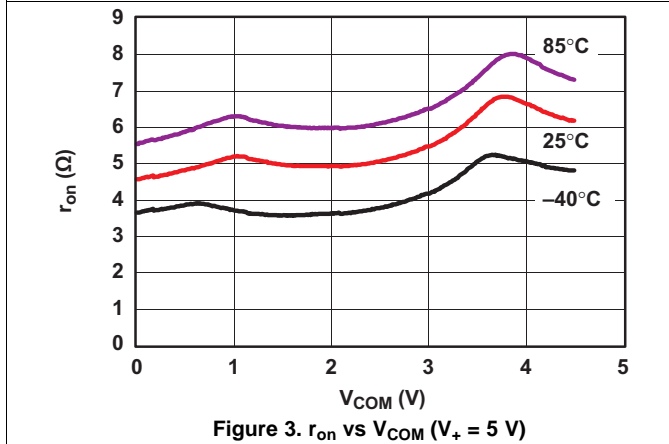
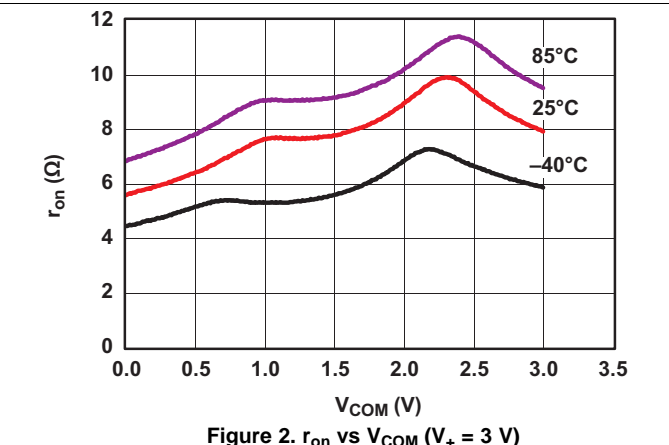
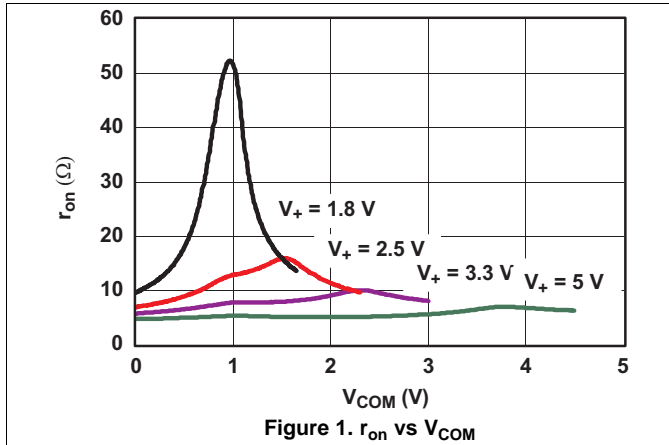

Typical Characteristics (continued)

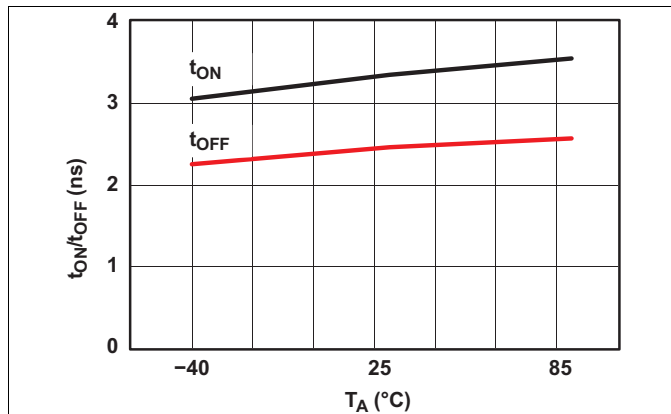

Figure 7. t_{ON} and t_{OFF} vs Temperature ($V_+ = 5\text{ V}$)

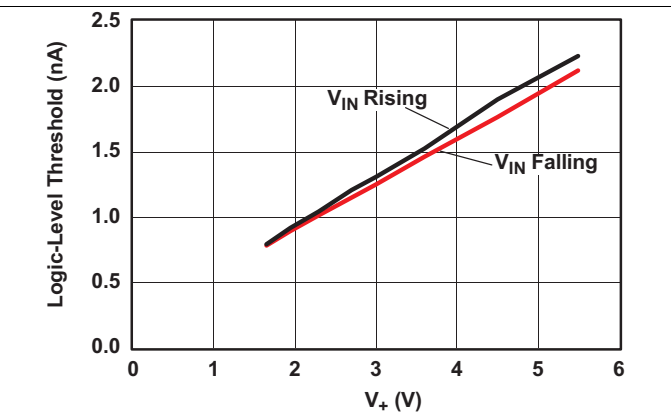

Figure 8. Logic-Level Threshold vs V_+

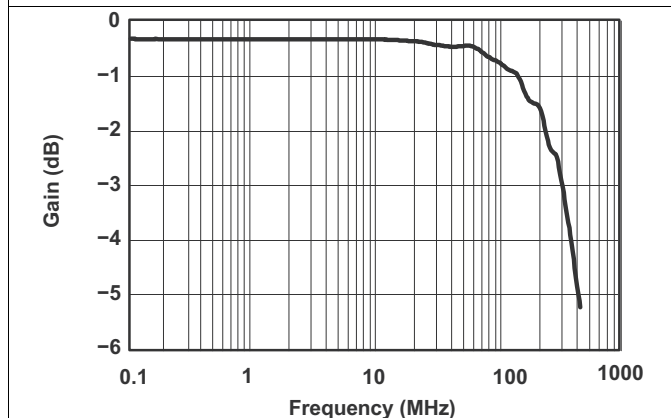

Figure 9. Bandwidth ($V_+ = 3.3\text{ V}$)

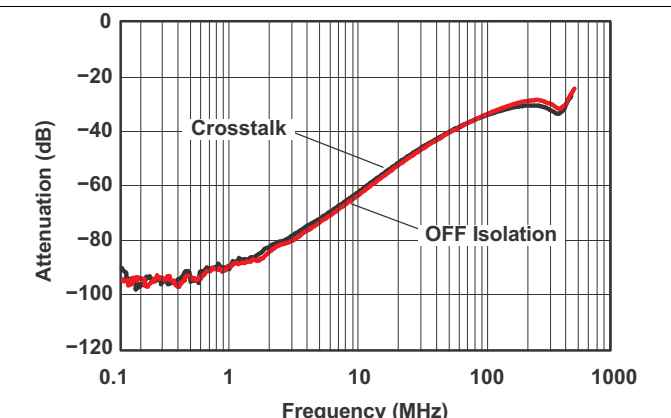

Figure 10. OFF Isolation and Crosstalk ($V_+ = 3.3\text{ V}$)

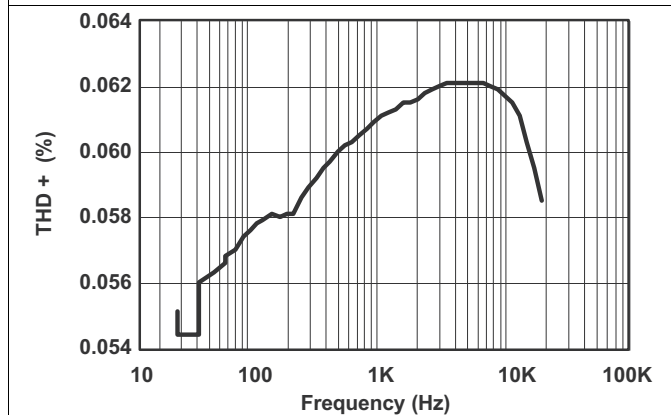

Figure 11. Total Harmonic Distortion (THD) vs Frequency ($V_+ = 3.3\text{ V}$)

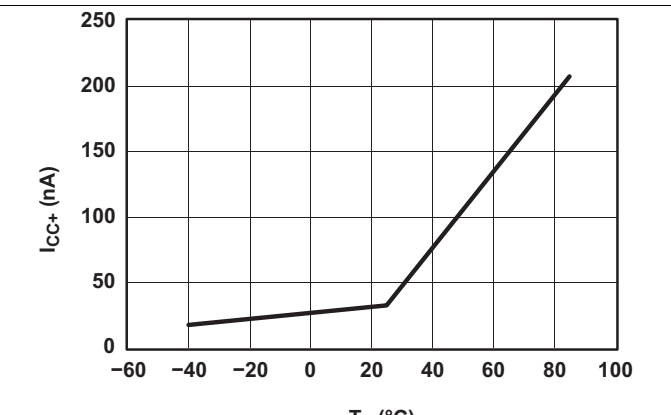

Figure 12. Power-Supply Current vs Temperature ($V_+ = 5\text{ V}$)

7 Parameter Measurement Information

Table 1. Parameter Description

| SYMBOL | DESCRIPTION |
|-------------------|--|
| V_{COM} | Voltage at COM |
| V_{NC} | Voltage at NC |
| V_{NO} | Voltage at NO |
| r_{on} | Resistance between COM and NC or COM and NO ports when the channel is ON |
| r_{peak} | Peak on-state resistance over a specified voltage range |
| Δr_{on} | Difference of r_{on} between channels in a specific device |
| $r_{on(flat)}$ | Difference between the maximum and minimum value of r_{on} in a channel over the specified range of conditions |
| $I_{NC(OFF)}$ | Leakage current measured at the NC port, with the corresponding channel (NC to COM) in the OFF state |
| $I_{NC(PWROFF)}$ | Leakage current measured at the NC port during the power-down condition, $V_+ = 0$ |
| $I_{NO(OFF)}$ | Leakage current measured at the NO port, with the corresponding channel (NO to COM) in the OFF state |
| $I_{NO(PWROFF)}$ | Leakage current measured at the NO port during the power-down condition, $V_+ = 0$ |
| $I_{NC(ON)}$ | Leakage current measured at the NC port, with the corresponding channel (NC to COM) in the ON state and the output (COM) open |
| $I_{NO(ON)}$ | Leakage current measured at the NO port, with the corresponding channel (NO to COM) in the ON state and the output (COM) open |
| $I_{COM(ON)}$ | Leakage current measured at the COM port, with the corresponding channel (COM to NO or COM to NC) in the ON state and the output (NC or NO) open |
| $I_{COM(PWROFF)}$ | Leakage current measured at the COM port during the power-down condition, $V_+ = 0$ |
| V_{IH} | Minimum input voltage for logic high for the control input (IN) |
| V_{IL} | Maximum input voltage for logic low for the control input (IN) |
| V_I | Voltage at the control input (IN) |
| I_{IH}, I_{IL} | Leakage current measured at the control input (IN) |
| t_{ON} | Turn-on time for the switch. This parameter is measured under the specified range of conditions and by the propagation delay between the digital control (IN) signal and analog output (COM or NO) signal when the switch is turning ON. |
| t_{OFF} | Turn-off time for the switch. This parameter is measured under the specified range of conditions and by the propagation delay between the digital control (IN) signal and analog output (COM or NO) signal when the switch is turning OFF. |
| t_{BBM} | Break-before-make time. This parameter is measured under the specified range of conditions and by the propagation delay between the output of two adjacent analog channels (NC and NO) when the control signal changes state. |
| Q_C | Charge injection is a measurement of unwanted signal coupling from the control (IN) input to the analog (NO or COM) output. This is measured in coulomb (C) and measured by the total charge induced due to switching of the control input. Charge injection, $Q_C = C_L \times \Delta V_{COM}$, C_L is the load capacitance and ΔV_{COM} is the change in analog output voltage. |
| $C_{NC(OFF)}$ | Capacitance at the NC port when the corresponding channel (NC to COM) is OFF |
| $C_{NO(OFF)}$ | Capacitance at the NO port when the corresponding channel (NO to COM) is OFF |
| $C_{NC(ON)}$ | Capacitance at the NC port when the corresponding channel (NC to COM) is ON |
| $C_{NO(ON)}$ | Capacitance at the NO port when the corresponding channel (NO to COM) is ON |
| $C_{COM(ON)}$ | Capacitance at the COM port when the corresponding channel (COM to NC or COM to NO) is ON |
| C_I | Capacitance of control input (IN) |
| O_{ISO} | OFF isolation of the switch is a measurement of OFF-state switch impedance. This is measured in dB in a specific frequency, with the corresponding channel (NC to COM or NO to COM) in the OFF state. |
| X_{TALK} | Crosstalk is a measurement of unwanted signal coupling from an ON channel to an OFF channel (NC to NO or NO to NC). This is measured in a specific frequency and in dB. |
| BW | Bandwidth of the switch. This is the frequency in which the gain of an ON channel is –3 dB below the DC gain. |
| THD | Total harmonic distortion is defined as the ratio of the root mean square (RMS) value of the second, third, and higher harmonics to the magnitude of fundamental harmonic. |
| I_+ | Static power-supply current with the control (IN) pin at V_+ or GND |
| V_{OUTU} | Output voltage during an undershoot event. This is measured by turning off a specific channel and applying an undershoot voltage at the input of the switch. |
| V_{OUTO} | Output voltage during an overshoot event. This is measured by turning off a specific channel and applying an overshoot voltage at the input of the switch. |

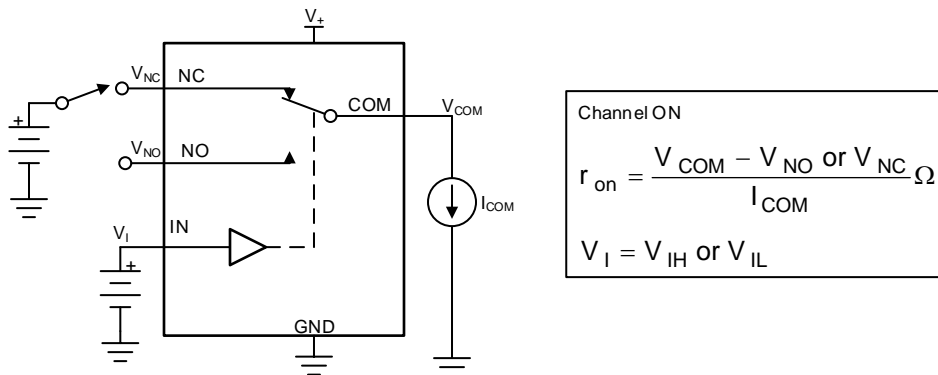

Figure 13. ON-State Resistance (r_{on})

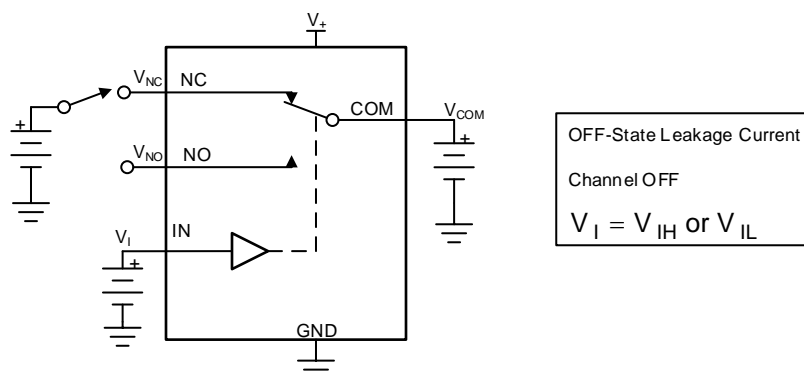

Figure 14. OFF-State Leakage Current ($I_{NC(OFF)}$, $I_{NC(PWROFF)}$, $I_{NO(OFF)}$, $I_{NO(PWROFF)}$, $I_{COM(OFF)}$, $I_{COM(PWROFF)}$)

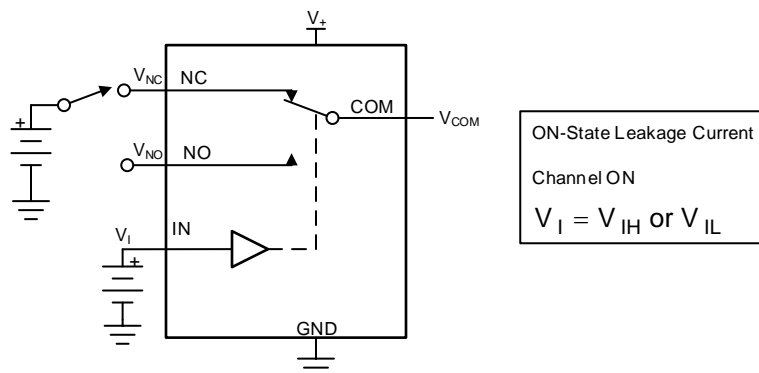

Figure 15. ON-State Leakage Current ($I_{COM(ON)}$, $I_{NC(ON)}$, $I_{NO(ON)}$)

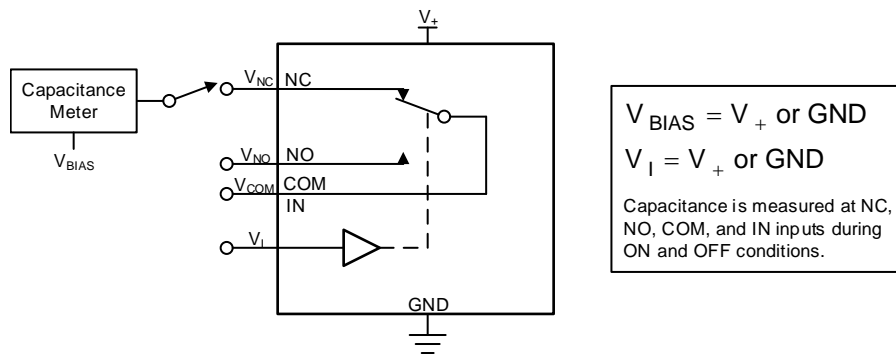
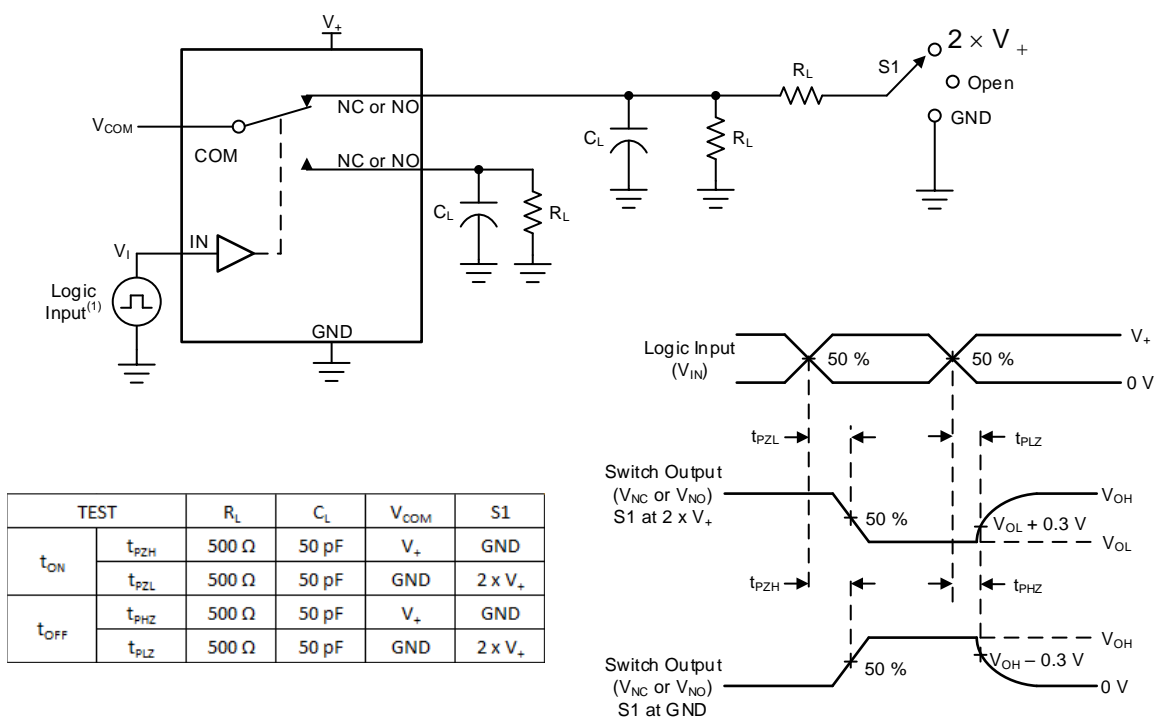

Figure 16. Capacitance (C_{IN} , $C_{COM(ON)}$, $C_{NC(OFF)}$, $C_{NO(OFF)}$, $C_{NC(ON)}$, $C_{NO(ON)}$)



(1) All input pulses are supplied by generators having the following characteristics: PRR \leq 10 MHz, $Z_O = 50 \Omega$, $t_r < 5$ ns, $t_f < 5$ ns.

Figure 17. Turn-On (t_{ON}) and Turn-Off (t_{OFF}) Time

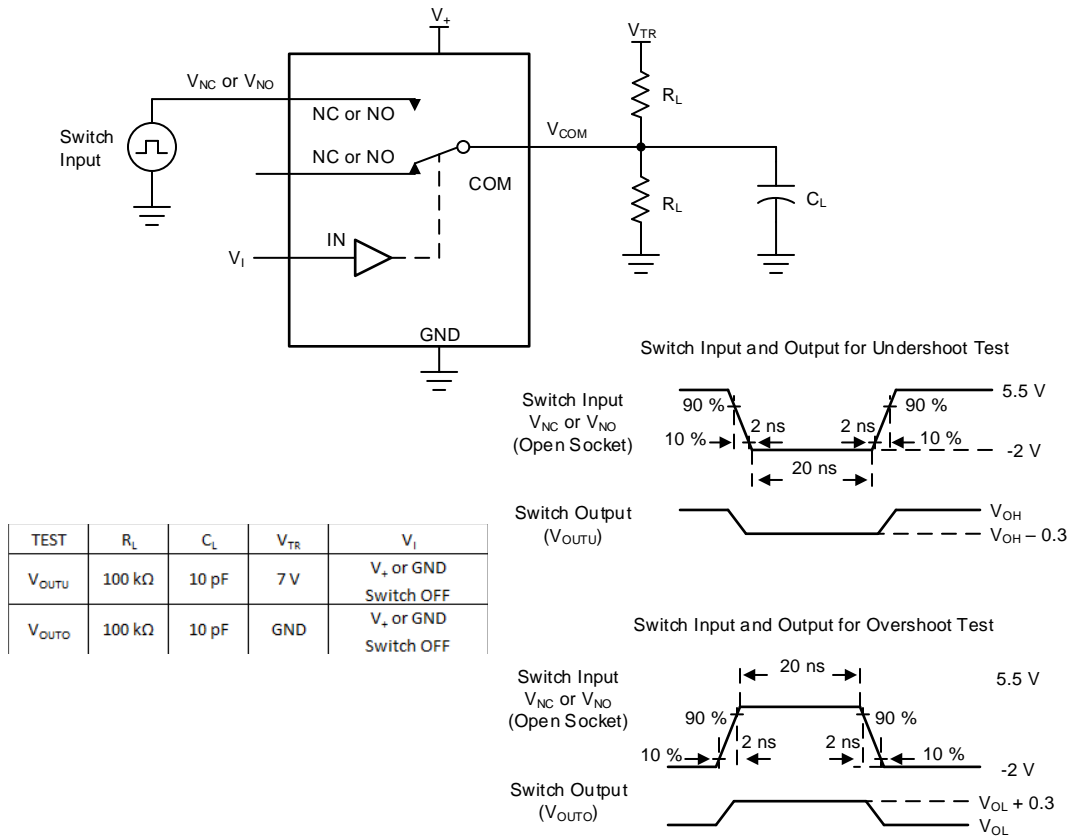
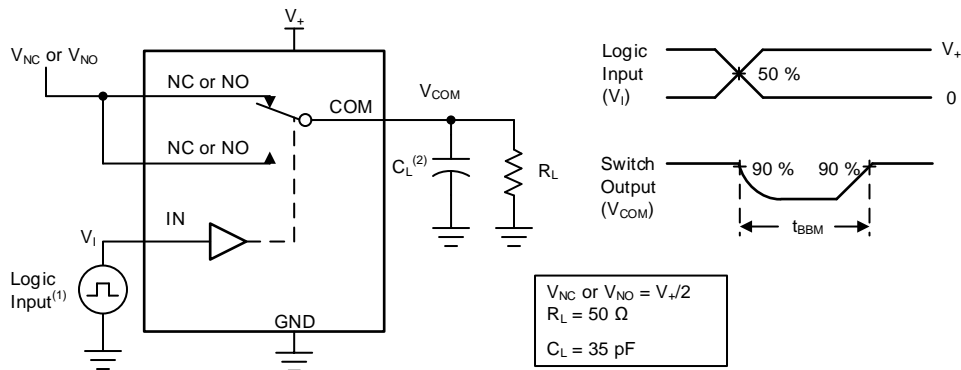

Figure 18. Undershoot and Overshoot Test



- (1) All input pulses are supplied by generators having the following characteristics: PRR ≤ 10 MHz, Z_O = 50 Ω, t_r < 5 ns, t_f < 5 ns.
- (2) C_L includes probe and jig capacitance.

Figure 19. Break-Before-Make (t_{BBM}) Time

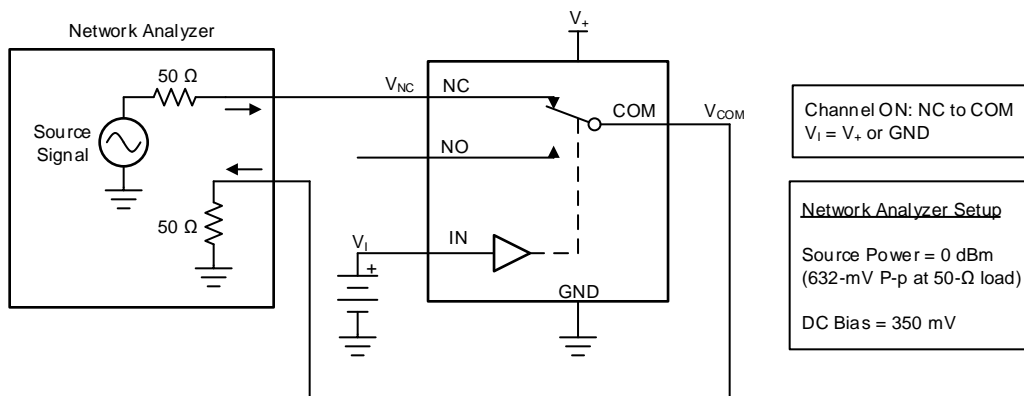

Figure 20. Bandwidth (BW)

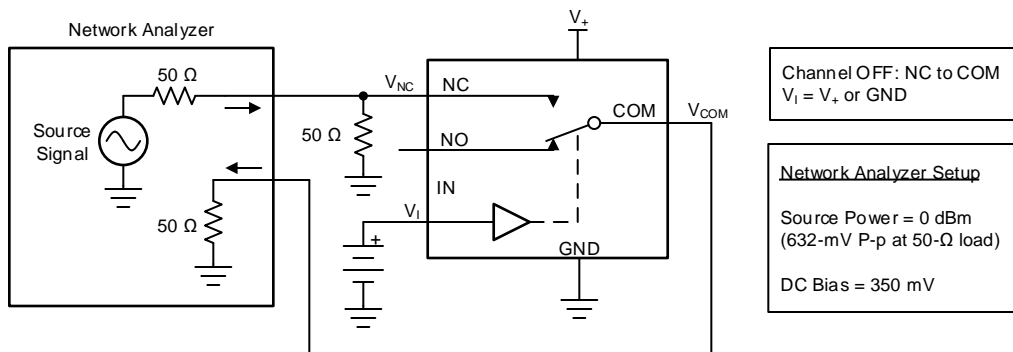

Figure 21. OFF Isolation (O_{ISO})

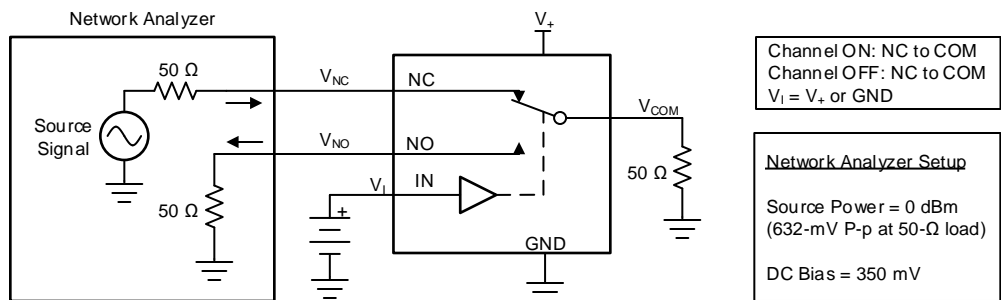
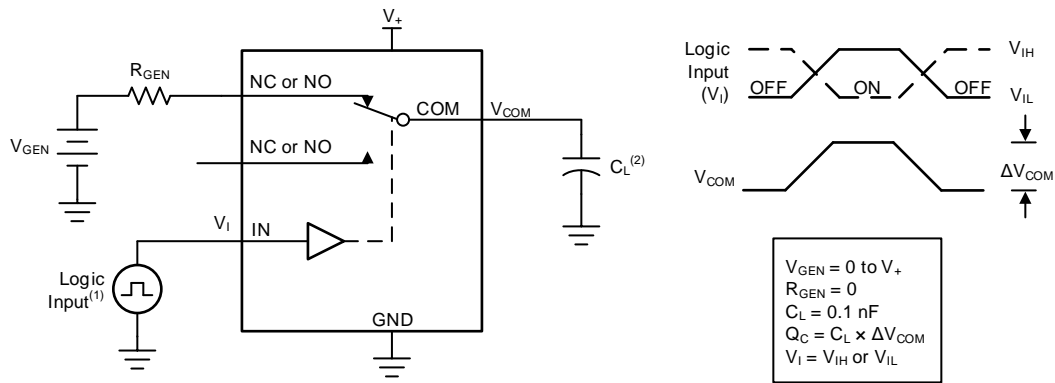
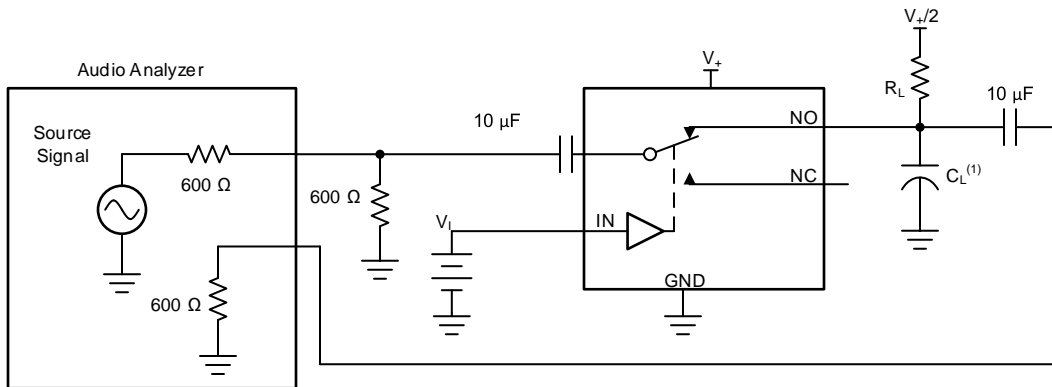

Figure 22. Crosstalk (X_{TALK})



- (1) All input pulses are supplied by generators having the following characteristics: PRR ≤ 10 MHz, Z_O = 50 Ω, t_r < 5 ns, t_f < 5 ns.
- (2) C_L includes probe and jig capacitance.

Figure 23. Charge Injection (Q_c)



- (1) C_L includes probe and jig capacitance.

Figure 24. Total Harmonic Distortion (THD)

8 Detailed Description

8.1 Overview

The TS5A63157 is a single-pole, double-throw (SPDT) analog switch designed to operate from 1.65 V to 5.5 V. This device can handle both digital and analog signals. Signals up to V_+ (peak) can be transmitted in either direction.

8.2 Functional Block Diagram

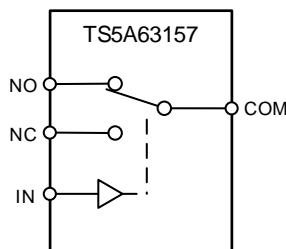

8.3 Feature Description

8.3.1 Integrated Overshoot and Undershoot Protection Circuitry

The TS5A63157 senses overshoot and undershoot events at the I/Os and responds by preventing voltage differentials from developing and turning the switch on.

8.3.2 Isolation in Powered-Off Mode, $V_+ = 0$ V

The TS5A63157 provides isolation when the supply voltage is removed ($V_+ = 0$ V). When the TMUX1511 is powered-off, the I/Os of the device remain in a high-Z state. Powered-off protection minimizes system complexity by removing the need for power supply sequencing on the signal path.

8.3.3 Break-before-make

Break-before-make delay is a safety feature that prevents two inputs from connecting when the device is switching. The output first breaks from the on-state switch before making the connection with the next on-state switch. The time delay between the break and the make is known as break-before-make delay.

8.4 Device Functional Modes

Table 2. Function Table

| IN | NC TO COM, COM TO NC | NO TO COM, COM TO NO |
|----|-------------------------|-------------------------|
| L | ON | OFF |
| H | OFF | ON |

9 Application and Implementation

NOTE

Information in the following applications sections is not part of the TI component specification, and TI does not warrant its accuracy or completeness. TI's customers are responsible for determining suitability of components for their purposes. Customers should validate and test their design implementation to confirm system functionality.

9.1 Application Information

The TS5A63157 can be used in a variety of customer systems. The TS5A63157 can be used anywhere multiple analog or digital signals must be selected to pass across a single line.

9.2 Typical Application

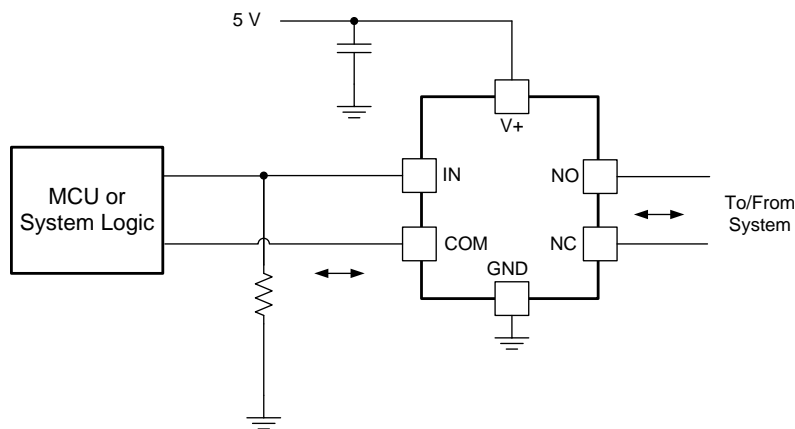

Figure 25. System Schematic for TS5A63157

9.2.1 Design Requirements

In this particular application, V_+ was 1.8 V, although V_+ is allowed to be any voltage specified in . A decoupling capacitor is recommended on the V_+ pin. See for more details.

9.2.2 Detailed Design Procedure

In this application, IN is, by default, pulled low to GND. Choose the resistor size based on the current driving strength of the GPIO, the desired power consumption, and the switching frequency (if applicable). If the GPIO is open-drain, use pullup resistors instead.

9.2.3 Application Curve

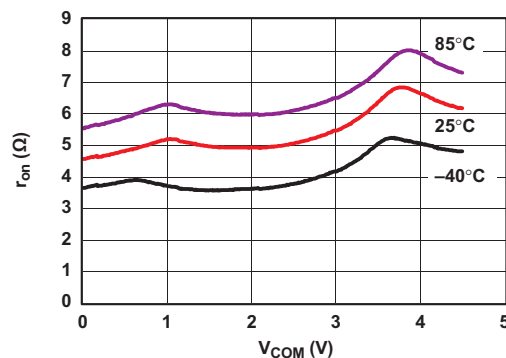

Figure 26. r_{on} vs V_{COM} , $V_+ = 5$ V

10 Power Supply Recommendations

The power supply can be any voltage between the minimum and maximum supply voltage rating located in the .

Each V_{CC} terminal should have a good bypass capacitor to prevent power disturbance. For devices with a single supply, a 0.1- μF bypass capacitor is recommended. If there are multiple pins labeled V_{CC} , then a 0.01- μF or 0.022- μF capacitor is recommended for each V_{CC} because the VCC pins will be tied together internally. For devices with dual supply pins operating at different voltages, for example V_{CC} and V_{DD} , a 0.1- μF bypass capacitor is recommended for each supply pin. It is acceptable to parallel multiple bypass capacitors to reject different frequencies of noise. 0.1- μF and 1- μF capacitors are commonly used in parallel. The bypass capacitor should be installed as close to the power terminal as possible for best results.

11 Layout

11.1 Layout Guidelines

Reflections and matching are closely related to loop antenna theory, but different enough to warrant their own discussion. When a PCB trace turns a corner at a 90° angle, a reflection can occur. This is primarily due to the change of width of the trace. At the apex of the turn, the trace width is increased to 1.414 times its width. This upsets the transmission line characteristics, especially the distributed capacitance and self-inductance of the trace — resulting in the reflection. It is a given that not all PCB traces can be straight, and so they will have to turn corners. Below figure shows progressively better techniques of rounding corners. Only the last example maintains constant trace width and minimizes reflections.

Unused switch I/Os, such as NO, NC, and COM, can be left floating or tied to GND. However, the IN pin must be driven high or low. Due to partial transistor turnon when control inputs are at threshold levels, floating control inputs can cause increased I_{CC} or unknown switch selection states.

11.2 Layout Example

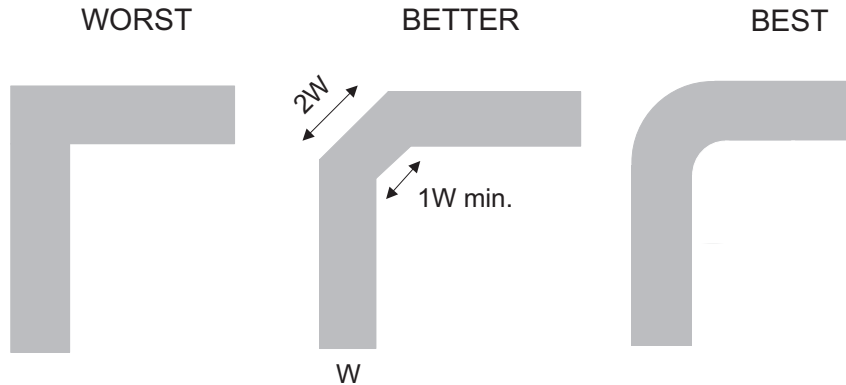

Figure 27. Trace Example

12 器件和文档支持

12.1 接收文档更新通知

要接收文档更新通知，请导航至 TI.com.cn 上的器件产品文件夹。单击右上角的 [通知我](#) 进行注册，即可每周接收产品信息更改摘要。有关更改的详细信息，请查看任何已修订文档中包含的修订历史记录。

12.2 社区资源

下列链接提供到 TI 社区资源的连接。链接的内容由各个分销商“按照原样”提供。这些内容并不构成 TI 技术规范，并且不一定反映 TI 的观点；请参阅 TI 的 [《使用条款》](#)。

TI E2E™ Online Community *TI's Engineer-to-Engineer (E2E) Community*. Created to foster collaboration among engineers. At e2e.ti.com, you can ask questions, share knowledge, explore ideas and help solve problems with fellow engineers.

Design Support *TI's Design Support* Quickly find helpful E2E forums along with design support tools and contact information for technical support.

12.3 商标

E2E is a trademark of Texas Instruments.
All other trademarks are the property of their respective owners.

12.4 静电放电警告



ESD 可能会损坏该集成电路。德州仪器 (TI) 建议通过适当的预防措施处理所有集成电路。如果不遵守正确的处理措施和安装程序，可能会损坏集成电路。

ESD 的损坏小至导致微小的性能降级，大至整个器件故障。精密的集成电路可能更容易受到损坏，这是因为非常细微的参数更改都可能会导致器件与其发布的规格不相符。

12.5 术语表

SLYZ022 — *TI 术语表*。

这份术语表列出并解释术语、缩写和定义。

13 机械、封装和可订购信息

以下页面包含机械、封装和可订购信息。这些信息是指定器件的最新可用数据。数据如有变更，恕不另行通知，且不会对此文档进行修订。如需获取此产品说明书的浏览器版本，请查阅左侧的导航栏。

PACKAGING INFORMATION

| Orderable part number | Status (1) | Material type (2) | Package Pins | Package qty Carrier | RoHS (3) | Lead finish/ Ball material (4) | MSL rating/ Peak reflow (5) | Op temp (°C) | Part marking (6) |
|---------------------------------|---------------|----------------------|------------------|-----------------------|-------------|--------------------------------------|-----------------------------------|--------------|---------------------|
| TS5A63157DBVR | Active | Production | SOT-23 (DBV) 6 | 3000 LARGE T&R | Yes | NIPDAU SN | Level-1-260C-UNLIM | -40 to 85 | (JBEF, JBER) |
| TS5A63157DBVR.B | Active | Production | SOT-23 (DBV) 6 | 3000 LARGE T&R | Yes | SN | Level-1-260C-UNLIM | -40 to 85 | (JBEF, JBER) |
| TS5A63157DBVRG4 | Active | Production | SOT-23 (DBV) 6 | 3000 LARGE T&R | Yes | NIPDAU | Level-1-260C-UNLIM | -40 to 85 | JBEF |
| TS5A63157DBVRG4.B | Active | Production | SOT-23 (DBV) 6 | 3000 LARGE T&R | Yes | NIPDAU | Level-1-260C-UNLIM | -40 to 85 | JBEF |
| TS5A63157DCKR | Active | Production | SC70 (DCK) 6 | 3000 LARGE T&R | Yes | NIPDAU SN | Level-1-260C-UNLIM | -40 to 85 | (J75, J7F, J7R) |
| TS5A63157DCKR.B | Active | Production | SC70 (DCK) 6 | 3000 LARGE T&R | Yes | SN | Level-1-260C-UNLIM | -40 to 85 | (J75, J7F, J7R) |
| TS5A63157DCKRG4 | Active | Production | SC70 (DCK) 6 | 3000 LARGE T&R | Yes | NIPDAU | Level-1-260C-UNLIM | -40 to 85 | J7F |
| TS5A63157DCKRG4.B | Active | Production | SC70 (DCK) 6 | 3000 LARGE T&R | Yes | NIPDAU | Level-1-260C-UNLIM | -40 to 85 | J7F |

(1) **Status:** For more details on status, see our [product life cycle](#).

(2) **Material type:** When designated, preproduction parts are prototypes/experimental devices, and are not yet approved or released for full production. Testing and final process, including without limitation quality assurance, reliability performance testing, and/or process qualification, may not yet be complete, and this item is subject to further changes or possible discontinuation. If available for ordering, purchases will be subject to an additional waiver at checkout, and are intended for early internal evaluation purposes only. These items are sold without warranties of any kind.

(3) **RoHS values:** Yes, No, RoHS Exempt. See the [TI RoHS Statement](#) for additional information and value definition.

(4) **Lead finish/Ball material:** Parts may have multiple material finish options. Finish options are separated by a vertical ruled line. Lead finish/Ball material values may wrap to two lines if the finish value exceeds the maximum column width.

(5) **MSL rating/Peak reflow:** The moisture sensitivity level ratings and peak solder (reflow) temperatures. In the event that a part has multiple moisture sensitivity ratings, only the lowest level per JEDEC standards is shown. Refer to the shipping label for the actual reflow temperature that will be used to mount the part to the printed circuit board.

(6) **Part marking:** There may be an additional marking, which relates to the logo, the lot trace code information, or the environmental category of the part.

Multiple part markings will be inside parentheses. Only one part marking contained in parentheses and separated by a "-" will appear on a part. If a line is indented then it is a continuation of the previous line and the two combined represent the entire part marking for that device.

Important Information and Disclaimer:The information provided on this page represents TI's knowledge and belief as of the date that it is provided. TI bases its knowledge and belief on information provided by third parties, and makes no representation or warranty as to the accuracy of such information. Efforts are underway to better integrate information from third parties. TI has taken and continues to take reasonable steps to provide representative and accurate information but may not have conducted destructive testing or chemical analysis on incoming materials and chemicals. TI and TI suppliers consider certain information to be proprietary, and thus CAS numbers and other limited information may not be available for release.

In no event shall TI's liability arising out of such information exceed the total purchase price of the TI part(s) at issue in this document sold by TI to Customer on an annual basis.

TAPE AND REEL INFORMATION

QUADRANT ASSIGNMENTS FOR PIN 1 ORIENTATION IN TAPE

*All dimensions are nominal

| Device | Package Type | Package Drawing | Pins | SPQ | Reel Diameter (mm) | Reel Width W1 (mm) | A0 (mm) | B0 (mm) | K0 (mm) | P1 (mm) | W (mm) | Pin1 Quadrant |
|-----------------|--------------|-----------------|------|------|--------------------|--------------------|---------|---------|---------|---------|--------|---------------|
| TS5A63157DBVR | SOT-23 | DBV | 6 | 3000 | 178.0 | 9.0 | 3.23 | 3.17 | 1.37 | 4.0 | 8.0 | Q3 |
| TS5A63157DBVRG4 | SOT-23 | DBV | 6 | 3000 | 178.0 | 9.0 | 3.23 | 3.17 | 1.37 | 4.0 | 8.0 | Q3 |
| TS5A63157DCKR | SC70 | DCK | 6 | 3000 | 180.0 | 8.4 | 2.3 | 2.5 | 1.2 | 4.0 | 8.0 | Q3 |
| TS5A63157DCKR | SC70 | DCK | 6 | 3000 | 178.0 | 9.0 | 2.4 | 2.5 | 1.2 | 4.0 | 8.0 | Q3 |
| TS5A63157DCKRG4 | SC70 | DCK | 6 | 3000 | 178.0 | 9.0 | 2.4 | 2.5 | 1.2 | 4.0 | 8.0 | Q3 |

TAPE AND REEL BOX DIMENSIONS

*All dimensions are nominal

| Device | Package Type | Package Drawing | Pins | SPQ | Length (mm) | Width (mm) | Height (mm) |
|-----------------|--------------|-----------------|------|------|-------------|------------|-------------|
| TS5A63157DBVR | SOT-23 | DBV | 6 | 3000 | 180.0 | 180.0 | 18.0 |
| TS5A63157DBVRG4 | SOT-23 | DBV | 6 | 3000 | 180.0 | 180.0 | 18.0 |
| TS5A63157DCKR | SC70 | DCK | 6 | 3000 | 210.0 | 185.0 | 35.0 |
| TS5A63157DCKR | SC70 | DCK | 6 | 3000 | 180.0 | 180.0 | 18.0 |
| TS5A63157DCKRG4 | SC70 | DCK | 6 | 3000 | 180.0 | 180.0 | 18.0 |

DCK0006A



PACKAGE OUTLINE

SOT - 1.1 max height

SMALL OUTLINE TRANSISTOR

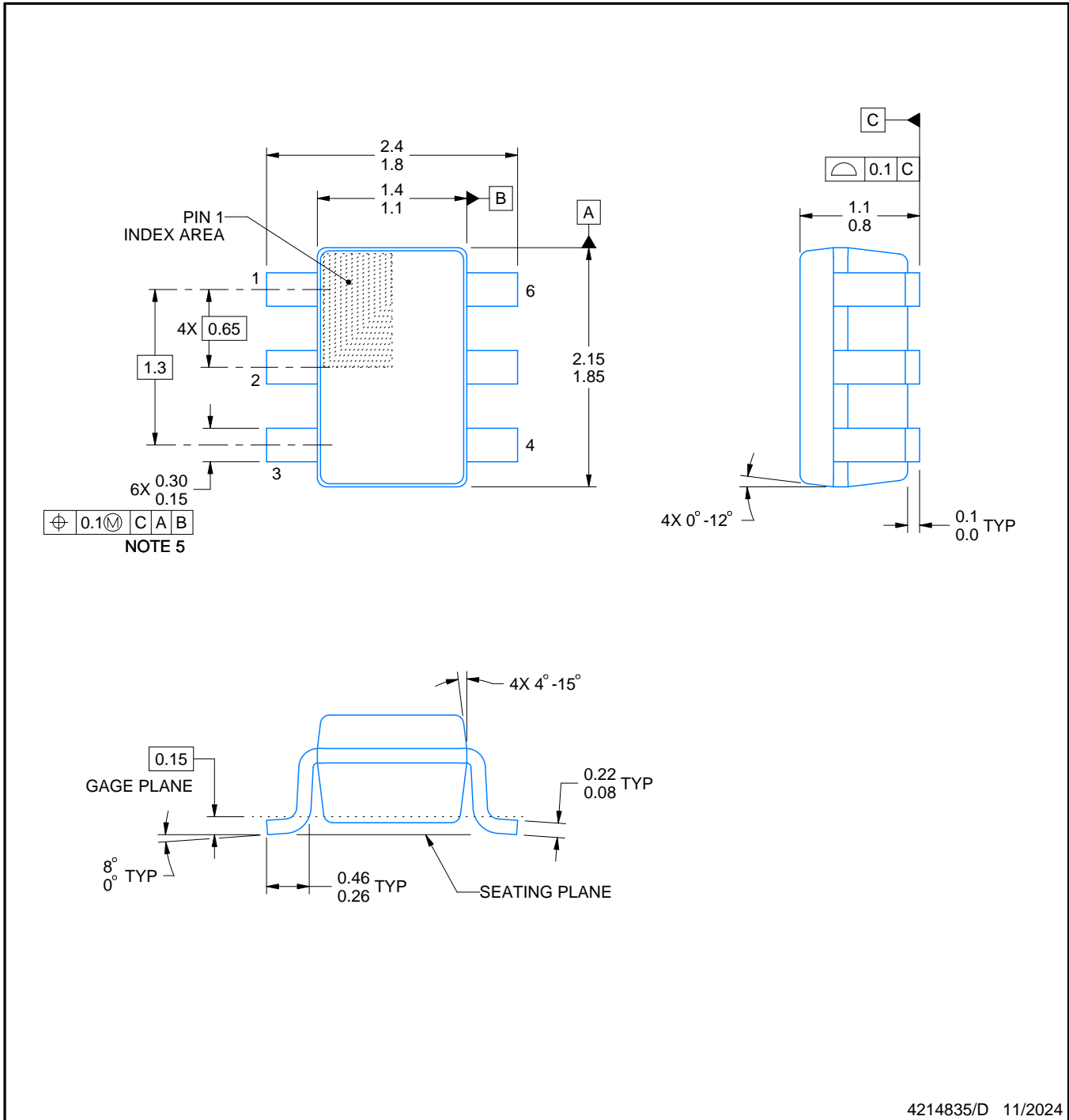

4214835/D 11/2024

NOTES:

1. All linear dimensions are in millimeters. Any dimensions in parenthesis are for reference only. Dimensioning and tolerancing per ASME Y14.5M.
2. This drawing is subject to change without notice.
3. Body dimensions do not include mold flash or protrusion. Mold flash and protrusion shall not exceed 0.15 per side.
4. Falls within JEDEC MO-203 variation AB.

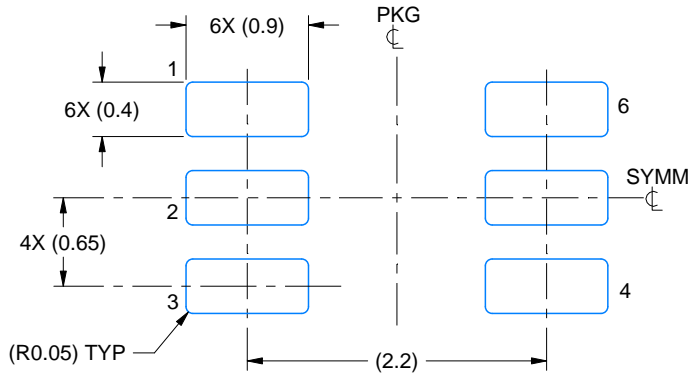

LAND PATTERN EXAMPLE
EXPOSED METAL SHOWN
SCALE:18X

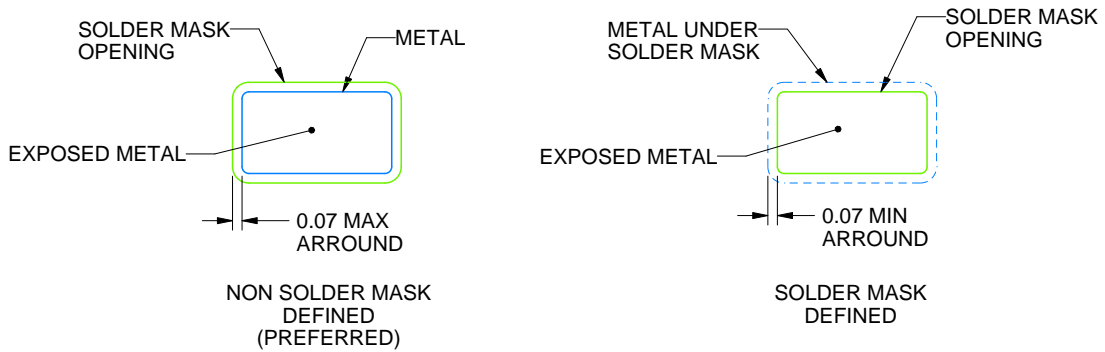

SOLDER MASK DETAILS

4214835/D 11/2024

NOTES: (continued)

- 5. Publication IPC-7351 may have alternate designs.
- 6. Solder mask tolerances between and around signal pads can vary based on board fabrication site.



SOLDER PASTE EXAMPLE
BASED ON 0.125 THICK STENCIL
SCALE:18X

4214835/D 11/2024

NOTES: (continued)

7. Laser cutting apertures with trapezoidal walls and rounded corners may offer better paste release. IPC-7525 may have alternate design recommendations.
8. Board assembly site may have different recommendations for stencil design.

EXAMPLE BOARD LAYOUT

DBV0006A

SOT-23 - 1.45 mm max height

SMALL OUTLINE TRANSISTOR



LAND PATTERN EXAMPLE
EXPOSED METAL SHOWN
SCALE:15X



SOLDER MASK DETAILS

4214840/G 08/2024

NOTES: (continued)

- 6. Publication IPC-7351 may have alternate designs.
- 7. Solder mask tolerances between and around signal pads can vary based on board fabrication site.

EXAMPLE STENCIL DESIGN

DBV0006A

SOT-23 - 1.45 mm max height

SMALL OUTLINE TRANSISTOR



SOLDER PASTE EXAMPLE
BASED ON 0.125 mm THICK STENCIL
SCALE:15X

4214840/G 08/2024

NOTES: (continued)

8. Laser cutting apertures with trapezoidal walls and rounded corners may offer better paste release. IPC-7525 may have alternate design recommendations.
9. Board assembly site may have different recommendations for stencil design.

重要通知和免责声明

TI“按原样”提供技术和可靠性数据（包括数据表）、设计资源（包括参考设计）、应用或其他设计建议、网络工具、安全信息和其他资源，不保证没有瑕疵且不做任何明示或暗示的担保，包括但不限于对适销性、与某特定用途的适用性或不侵犯任何第三方知识产权的暗示担保。

这些资源可供使用 TI 产品进行设计的熟练开发人员使用。您将自行承担以下全部责任：(1) 针对您的应用选择合适的 TI 产品，(2) 设计、验证并测试您的应用，(3) 确保您的应用满足相应标准以及任何其他安全、安保法规或其他要求。

这些资源如有变更，恕不另行通知。TI 授权您仅可将这些资源用于研发本资源所述的 TI 产品的相关应用。严禁以其他方式对这些资源进行复制或展示。您无权使用任何其他 TI 知识产权或任何第三方知识产权。对于因您对这些资源的使用而对 TI 及其代表造成的任何索赔、损害、成本、损失和债务，您将全额赔偿，TI 对此概不负责。

TI 提供的产品受 [TI 销售条款](#)、[TI 通用质量指南](#) 或 [ti.com](#) 上其他适用条款或 TI 产品随附的其他适用条款的约束。TI 提供这些资源并不会扩展或以其他方式更改 TI 针对 TI 产品发布的适用的担保或担保免责声明。除非德州仪器 (TI) 明确将某产品指定为定制产品或客户特定产品，否则其产品均为按确定价格收入目录的标准通用器件。

TI 反对并拒绝您可能提出的任何其他或不同的条款。

版权所有 © 2026，德州仪器 (TI) 公司

最后更新日期：2025 年 10 月