

TSC2013-Q1 具有 I²C 接口的 12 位、毫微功耗 4 线 双触摸屏控制器

1 特性

- 符合汽车应用要求
- 具有符合 AEC-Q100 的下列结果：
 - 器件温度 1 级：-40°C 至 125°C 的
 - 器件人体模型 (HBM) 静电放电 (ESD) 分类等级 2
 - 器件充电器件模型 (CDM) ESD 分类等级 C4B
- 4 线制触摸屏界面
- 比例换算
- 1.6V 至 3.6V 单电源：
 - I/OVDD 1.2V 至 3.6V
 - SNSVDD: 1.6V 至 3.6V
- 通过预处理减少总线活动
- 高速 I²C 兼容接口
- 屏幕触摸内部检测
- 基于寄存器可编程：
 - 10 位或 12 位分辨率
 - 采样速率
 - 系统时序
- 触摸压力测量
- 自动断电控制
- 低功耗：
 - 1.8V, 50SSPS 时为 430μA
 - 1.6V, 50SSPS 时为 320μA
 - 1.6V, 8.2kSPS (设备采样率) 时为 58μA

2 应用

- 汽车信息娱乐显示屏
- 汽车导航系统
- 工业用户界面
- 医疗设备
- 消费类便携电子产品

3 说明

TSC2013-Q1 器件是一款超低功耗双触摸屏控制器，设计用于搭配汽车信息娱乐和导航系统中的功耗敏感型低成本触摸显示屏使用。其具有完整的超低功耗 12 位模数转换 (ADC) 电阻式触摸屏转换器，包括驱动器和测量触摸压力的控制逻辑。

TSC2013-Q1 器件可通过标准四线制界面实现捏拉缩放和旋转功能。针对所有三种定义模式（标准、快速与高速），该器件均支持 I²C 串行总线与数据传输协议。可轻松对 10 或 12 位范围内的 ADC 进行编程，以实现系统和用户体验的自定义。

器件信息 (1)

部件号	封装	封装尺寸 (标称值)
TSC2013-Q1	PVQFN (16)	4.00mm x 4.00mm
	TSSOP (16)	4.40mm x 5.00mm

(1) 要了解所有可用封装，请见数据表末尾的可订购产品附录。

方框图

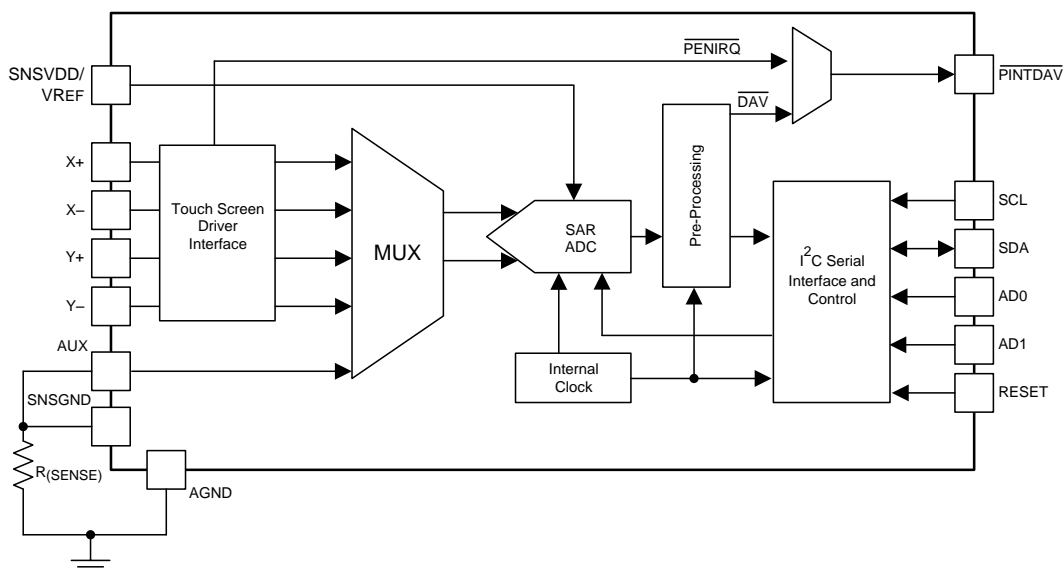

目录

1	特性	1	7	Detailed Description	12
2	应用	1	7.1	Overview	12
3	说明	1	7.2	Functional Block Diagram	13
4	修订历史记录	2	7.3	Feature Description	14
5	Pin Configurations and Functions	3	7.4	Device Functional Modes	23
6	Specifications	4	7.5	Programming	29
6.1	Absolute Maximum Ratings	4	7.6	Register Maps	41
6.2	Handling Ratings	4	8	Application and Implementation	51
6.3	Recommended Operating Conditions	4	8.1	Application Information	51
6.4	Thermal Information	4	8.2	Typical Application	52
6.5	Electrical Characteristics	5	9	Power Supply Recommendations	60
6.6	Timing Requirements — I ² C Standard Mode ($f_{(SCL)} = 100$ kHz)	7	10	Layout	60
6.7	Timing Requirements — I ² C Fast Mode ($f_{(SCL)} = 400$ kHz)	7	10.1	Layout Guidelines	60
6.8	Timing Requirements — I ² C High-Speed Mode ($f_{(SCL)} = 1.7$ MHz)	8	10.2	Layout Example	61
6.9	Timing Requirements — I ² C High-Speed Mode ($f_{(SCL)} = 3.4$ MHz)	8	11	器件和文档支持	61
6.10	Typical Characteristics	10	11.1	商标	61
			11.2	静电放电警告	61
			11.3	术语表	61
			12	机械封装和可订购信息	61

4 修订历史记录

Changes from Original (June 2014) to Revision A

Page

•	发布了完整版数据表	1
•	已更改 已将器件状态从产品预览更改为生产数据	1

5 Pin Configurations and Functions

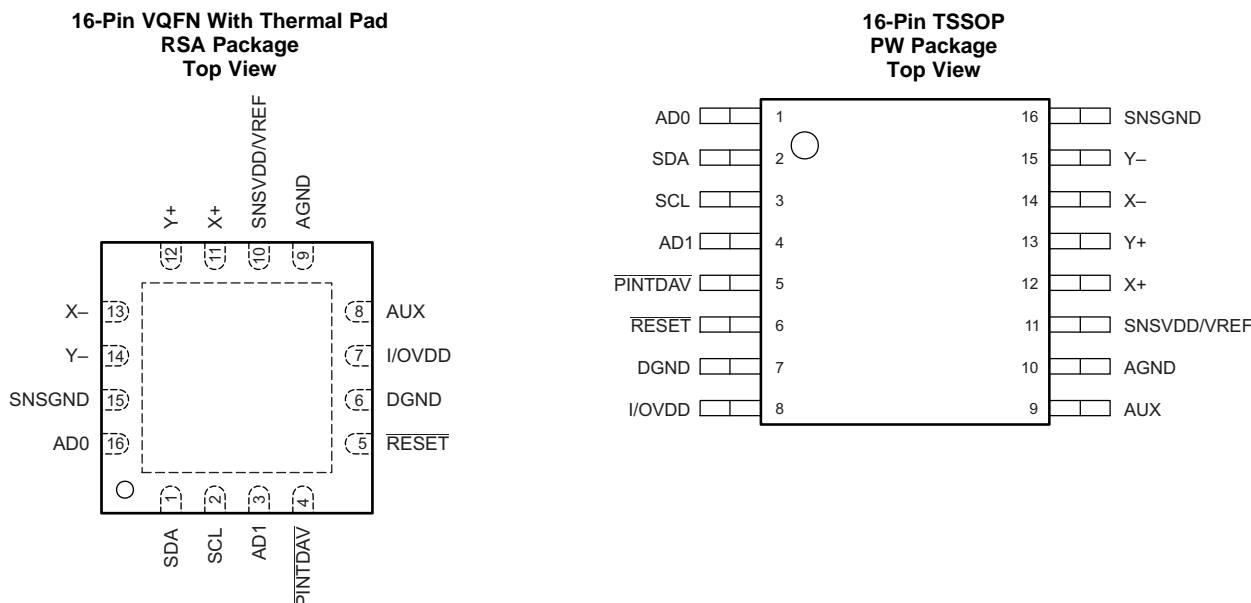

Pin Functions

PIN			I/O	ADC	DESCRIPTION
NAME	RSA	PW			
AD0	16	1	I	D	I ² C bus TSC address input bit 0
AD1	3	4	I	D	I ² C bus TSC address input bit 1
AGND	9	10	—	—	Analog, digital, and ESD ground ⁽¹⁾
AUX	8	9	—	A	Auxiliary channel
DGND	6	7	—	—	No internal connection. Connect this pin to analog ground for mechanical stability.
I/OVDD	7	8	I	—	Digital interface voltage
PINTDAV	4	5	O	D	Interrupt output. Data available or the pen-detect interrupt ($\overline{\text{PENIRQ}}$), depending on setting. Pin polarity is active-low.
RESET	5	6	I	D	External hardware reset input (active-low).
SDA	1	2	I/O	D	Serial data I/O
SCL	2	3	I	D	Serial clock
SNSGND	15	16	—	—	Sensor driver return
SNSVDD/VREF	10	11	I	—	Power supply for sensor drivers and other analog blocks
X+	11	12	—	A	X+ channel
X-	13	14	—	A	X- channel
Y+	12	13	—	A	Y+ channel
Y-	14	15	—	A	Y- channel

(1) For optimized system IEC ESD performance, contact Texas Instruments for schematic and layout reviews and suggestions.

6 Specifications

6.1 Absolute Maximum Ratings⁽¹⁾

Over operating free-air temperature range (unless otherwise noted).

		MIN	MAX	UNIT
Voltage	Analog input X+, Y+, AUX to SNSGND	-0.4	SNSVDD + 0.1	V
	Analog input X-, Y- to SNSGND	-0.4	SNSVDD + 0.1	V
	SNSVDD to SNSGND	-0.3	5	V
	SNSVDD to AGND	-0.3	5	V
	I/OVDD to AGND	-0.3	5	V
	SNSVDD to I/OVDD	-2.4	0.3	V
Digital input voltage to AGND		-0.3	I/OVDD + 0.3	V
Digital output voltage to AGND		-0.3	I/OVDD + 0.3	V
Power dissipation		$(T_{Jmax} - T_A) / R_{\theta JA}$		
Operating free-air temperature range, T_A		-40	125	°C
Junction temperature, T_{Jmax}			150	°C

- (1) Stresses beyond those listed under *Absolute Maximum Ratings* may cause permanent damage to the device. These are stress ratings only, and functional operation of the device at these or any other conditions beyond those indicated is not implied. Exposure to absolute-maximum rated conditions for extended periods may affect device reliability.

6.2 Handling Ratings

		MIN	MAX	UNIT		
T_{stg}	Storage temperature range	-65	150	°C		
$V_{(ESD)}$	Electrostatic discharge	Human body model (HBM), per AEC Q100-002 ⁽¹⁾	-2000	2000	V	
		Charged device model (CDM), per AEC Q100-011	Corner pins (RSA: 1, 4, 5, 8, 9, 12, 13, and 16; PW: 1, 8, 9, and 16)	-750		750
			Other pins	-500		500
	IEC contact discharge ⁽²⁾	X+, X-, Y+, Y-	-15	15	kV	
	IEC air discharge ⁽²⁾	X+, X-, Y+, Y-	-25	25	kV	

- (1) AEC Q100-002 indicates HBM stressing is done in accordance with the ANSI/ESDA/JEDEC JS-001 specification.
 (2) Test method based on IEC standard 61000-4-2. Contact Texas Instruments for test details.

6.3 Recommended Operating Conditions

over operating free-air temperature range (unless otherwise noted)

	MIN	NOM	MAX	UNIT
Input voltage SNSVDD/VR	1.6	3.3	3.6	V
Input voltage I/OVDD	1.2	3.3	3.6	V

6.4 Thermal Information

THERMAL METRIC ⁽¹⁾		RSA 16 PINS	PW 16 PINS	UNIT
$R_{\theta JA}$	Junction-to-ambient thermal resistance	33.7	100.9	°C/W
$R_{\theta JC(top)}$	Junction-to-case(top) thermal resistance	36.7	36.1	°C/W
$R_{\theta JB}$	Junction-to-board thermal resistance	10.5	45.7	°C/W
Ψ_{JT}	Junction-to-top characterization parameter	0.6	2.6	°C/W
Ψ_{JB}	Junction-to-board characterization parameter	10.5	45.1	°C/W
$R_{\theta JC(bot)}$	Junction-to-case(bottom) thermal resistance	2.5	—	°C/W

- (1) For more information about traditional and new thermal metrics, see the *IC Package Thermal Metrics* application report, [SPRA953](#).

6.5 Electrical Characteristics

At $T_A = -40^\circ\text{C}$ to 125°C , $V_{(\text{SNSVDD}/\text{VREF})} = 1.6\text{ V}$ to 3.6 V , and $V_{(\text{I/OVDD})}^{(1)} = 1.2\text{ V}$ to $V_{(\text{SNSVDD}/\text{VREF})}$, unless otherwise noted.

PARAMETER		TEST CONDITIONS	MIN	TYP	MAX	UNIT
AUXILIARY ANALOG INPUT						
Input voltage			0		V_{ref}	V
Input capacitance				12		pF
Input leakage current		No ADC conversion	-1		1	μA
Full-scale average input current		$V_{(\text{SNSVDD}/\text{VREF})} = 1.6\text{ V}$, continuous AUX, $f_{(\text{ADC})} = 2\text{ MHz}$		2		μA
ADC						
Resolution		Programmable: 10 or 12 bits			12	Bits
No missing codes		12-bit resolution	11			Bits
Integral linearity		12-bit resolution mode, $f_{(\text{ADC})} = 2\text{ MHz}$	-3	-0.5 to 0.5	3	LSB ⁽²⁾
Differential linearity		12-bit resolution mode, $f_{\text{ADC}} = 2\text{ MHz}$	-2	-0.5 to 0.5	4	LSB
Offset error		$V_{(\text{SNSVDD}/\text{VREF})} = 1.6\text{ V}$, 12-bit mode, $f_{(\text{ADC})} = 2\text{ MHz}$, filter off		0.2		LSB
Gain error		$V_{(\text{SNSVDD}/\text{VREF})} = 1.6\text{ V}$, 12-bit mode, $f_{(\text{ADC})} = 2\text{ MHz}$, filter off		2		LSB
Data format				Straight binary		
REFERENCE INPUT						
V_{ref} range			1.6	$V_{(\text{SNSVDD}/\text{VREF})}$		V
SNSVDD/VREF input-current drain		Continuous AUX mode, $V_{(\text{SNSVDD}/\text{VREF})} = 1.6\text{ V}$, $f_{(\text{ADC})} = 2\text{ MHz}$		5		μA
Input impedance		No ADC conversion		> 100		M Ω
TOUCH SENSORS						
X+ 50-k Ω pullup resistor, $R_{(\text{IRO})}$				52		k Ω
Switch on-resistance	Y+, X+	$T_A = 25^\circ\text{C}$, $V_{(\text{SNSVDD}/\text{VREF})} = 1.6\text{ V}$		7		Ω
	Y-, X-	$T_A = 25^\circ\text{C}$, $V_{(\text{SNSVDD}/\text{VREF})} = 1.6\text{ V}$		5		Ω
Switch drivers drive current		100-ms duration			50	mA
INTERNAL OSCILLATOR						
$f_{(\text{OSC})}$	Clock frequency	$V_{(\text{SNSVDD}/\text{VREF})} = 1.6\text{ V}$, $T_A = 25^\circ\text{C}$	3.3	3.7	4.3	MHz
		$V_{(\text{SNSVDD}/\text{VREF})} = 3\text{ V}$, $T_A = 25^\circ\text{C}$		3.8		MHz
Frequency drift		$V_{(\text{SNSVDD}/\text{VREF})} = 1.6\text{ V}$		-0.008		%/ $^\circ\text{C}$
		$V_{(\text{SNSVDD}/\text{VREF})} = 3\text{ V}$		-0.021		%/ $^\circ\text{C}$
DIGITAL INPUT/OUTPUT						
Logic family			CMOS			
V_{IH}	Input-voltage logic-level high	$1.2\text{ V} \leq V_{(\text{I/OVDD})} < 3\text{ V}$	$0.7 \times V_{(\text{I/OVDD})}$		3.6	V
V_{IL}	Input-voltage logic-level low	$1.2\text{ V} \leq V_{(\text{I/OVDD})} < 3\text{ V}$	-0.3	$0.2 \times V_{(\text{I/OVDD})}$		V
I_{IL} , I_{IH}	Input-current logic-level low and high		-1		1	μA
C_{I}	Input-capacitance logic level				10	pF
V_{OH}	Output-voltage logic-level high	$I_{\text{OH}} = 100\text{ }\mu\text{A}$	$V_{(\text{I/OVDD})} - 0.2$		$V_{(\text{I/OVDD})}$	V
V_{OL}	Output-voltage logic-level low	$I_{\text{OL}} = -3.2\text{ mA}$	0		0.2	V
I_{kg}	Leakage-current logic level	SDA	-1		1	μA
C_{O}	Output-capacitance logic level	SDA			10	pF
POWER-SUPPLY REQUIREMENTS						
Power-supply voltage						
SNSVDD			1.6		3	V
I/OVDD ⁽¹⁾			1.2	$V_{(\text{SNSVDD}/\text{VREF})}$		V

(1) I/OVDD must be \leq SNSVDD.

(2) LSB means least-significant bit. With SNSVDD/VREF = 2.5 V, one LSB is 610 μV .

Electrical Characteristics (接下页)

At $T_A = -40^\circ\text{C}$ to 125°C , $V_{(SNSVDD/VREF)} = 1.6\text{ V}$ to 3.6 V , and $V_{(I/OVDD)}^{(1)} = 1.2\text{ V}$ to $V_{(SNSVDD/VREF)}$, unless otherwise noted.

PARAMETER	TEST CONDITIONS	MIN	TYP	MAX	UNIT
Quiescent supply current ⁽³⁾⁽⁴⁾	$T_A = 25^\circ\text{C}$, filter off, $M = W = 1$, $C[3:0] = (1, 0, 0, 0)$, $RM = 1$, $CL[1:0] = (0, 1)$, cont AUX mode, $f_{(ADC)} = 2\text{ MHz}$, without reading data register $V_{(SNSVDD/VREF)} = V_{(I/OVDD)} = 1.6\text{ V}$		420	570	μA
	$T_A = 25^\circ\text{C}$, filter on, $M = 15$, $W = 7$, $PSM = 1$, $C[3:0] = (0, 0, 0, 0)$, $RM = 1$, $CL[1:0] = (0, 1)$, $BTD[2:0] = (1, 0, 1)$, 50 SSPs, $MAVEY = MAVEZ = 1$, $f_{(ADC)} = 2\text{ MHz}$, sensor drivers supply included ⁽⁵⁾ $V_{(SNSVDD/VREF)} = V_{(I/OVDD)} = 1.6\text{ V}$			200	μA
	$T_A = 25^\circ\text{C}$, filter on, $M = 15$, $W = 7$, $PSM = 1$, $C[3:0] = (0, 0, 0, 0)$, $RM = 1$, $CL[1:0] = (0, 1)$, $BTD[2:0] = (1, 0, 1)$, 50 SSPs, $MAVEY = MAVEZ = 1$, $f_{(ADC)} = 2\text{ MHz}$, sensor drivers supply included ⁽⁵⁾ $V_{(SNSVDD/VREF)} = V_{(I/OVDD)} = 3\text{ V}$			400	μA
	$T_A = 25^\circ\text{C}$, filter off, $M = W = 1$, $PSM = 1$, $C[3:0] = (0, 0, 0, 0)$, $RM = 1$, $CL[1:0] = (0, 1)$, $BTD[2:0] = (1, 0, 1)$, 50 SSPs, $MAVEY = MAVEZ = 1$, $f_{(ADC)} = 2\text{ MHz}$, sensor drivers supply included ⁽⁵⁾ $V_{(SNSVDD/VREF)} = V_{(I/OVDD)} = 1.6\text{ V}$			180	μA
	$T_A = 25^\circ\text{C}$, filter off, $M = W = 1$, $PSM = 1$, $C[3:0] = (0, 0, 0, 0)$, $RM = 1$, $CL[1:0] = (0, 1)$, $BTD[2:0] = (1, 0, 1)$, 50 SSPs, $MAVEY = MAVEZ = 1$, $f_{(ADC)} = 2\text{ MHz}$, sensor drivers supply included ⁽⁵⁾ $V_{(SNSVDD/VREF)} = V_{(I/OVDD)} = 3\text{ V}$			370	μA
	$T_A = 25^\circ\text{C}$, filter off, $M = W = 1$, $C[3:0] = (0, 1, 0, 1)$, $RM = 1$, $CL[1:0] = (0, 1)$, non-cont AUX mode, $f_{(ADC)} = 2\text{ MHz}$, high-speed mode $V_{(SNSVDD/VREF)} = V_{(I/OVDD)} = 1.6\text{ V}$, approximately 28 kSPS effective rate			190	μA
	$T_A = 25^\circ\text{C}$, filter off, $M = W = 1$, $C[3:0] = (0, 1, 0, 1)$, $RM = 1$, $CL[1:0] = (0, 1)$, non-cont AUX mode, $f_{(ADC)} = 2\text{ MHz}$, high-speed mode $V_{(SNSVDD/VREF)} = V_{(I/OVDD)} = 3\text{ V}$, approximately 28.4 kSPS effective rate			370	μA
	$T_A = 25^\circ\text{C}$, filter on, $M = 7$, $W = 3$, $C[3:0] = (0, 1, 0, 1)$, $RM = 1$, $CL[1:0] = (0, 1)$, $MAVEAUX = 1$, non-cont AUX mode, $f_{(ADC)} = 2\text{ MHz}$, high-speed mode, full speed $V_{(SNSVDD/VREF)} = V_{(I/OVDD)} = 1.6\text{ V}$, approximately 10.5 kSPS effective rate			355	μA
	$T_A = 25^\circ\text{C}$, filter on, $M = 7$, $W = 3$, $C[3:0] = (0, 1, 0, 1)$, $RM = 1$, $CL[1:0] = (0, 1)$, $MAVEAUX = 1$, non-cont AUX mode, $f_{(ADC)} = 2\text{ MHz}$, high-speed mode, full speed $V_{(SNSVDD/VREF)} = V_{(I/OVDD)} = 3\text{ V}$, approximately 10.9 kSPS effective rate			655	μA
	$T_A = 25^\circ\text{C}$, filter on, $M = 7$, $W = 3$, $C[3:0] = (0, 1, 0, 1)$, $RM = 1$, $CL[1:0] = (0, 1)$, $MAVEAUX = 1$, non-cont AUX mode, $f_{(ADC)} = 2\text{ MHz}$, high-speed mode, reduced speed (8.2-kSPS equivalent rate) $V_{(SNSVDD/VREF)} = V_{(I/OVDD)} = 1.6\text{ V}$, approximately 1.17 kSPS effective rate			36.2	μA
	$T_A = 25^\circ\text{C}$, filter on, $M = 7$, $W = 3$, $C[3:0] = (0, 1, 0, 1)$, $RM = 1$, $CL[1:0] = (0, 1)$, $MAVEAUX = 1$, non-cont AUX mode, $f_{(ADC)} = 2\text{ MHz}$, high-speed mode, reduced speed (8.2-kSPS equivalent rate) $V_{(SNSVDD/VREF)} = V_{(I/OVDD)} = 3\text{ V}$, approximately 1.17 kSPS effective rate			64.9	μA
Power-down supply current	$T_A = 25^\circ\text{C}$, not addressed, $SCL = SDA = 1$, $\overline{RESET} = 1$, $PINTDAV = 1$, $V_{(SNSVDD/VREF)} = I/OVDD = V_{ref} = 1.6\text{ V}$		0.04	0.8	μA
Digital power-down supply current	$T_A = 25^\circ\text{C}$, not addressed, $SCL = SDA = 1$, $\overline{RESET} = 1$, $PINTDAV = 1$, $V_{(SNSVDD/VREF)} = V_{(I/OVDD)} = V_{ref} = 1.6\text{ V}$		0.04	0.8	μA

- (3) Supply current from SNSVDD.
- (4) For detailed information on test condition parameter and bit settings, see the section.
- (5) Touch sensor modeled by 2 k Ω for X– plane and Y– plane, and 1 k Ω for Z–plane (touch resistance).

6.6 Timing Requirements — I²C Standard Mode ($f_{(SCL)} = 100 \text{ kHz}$)

All specifications typical at -40°C to 125°C , $V_{(SNSVDD/VREF)} = V_{(I/OVDD)} = 1.6 \text{ V}$ to 3 V , unless otherwise noted.

			MIN	MAX	UNIT
$t_{(WL_RESET)}$	Reset low time ⁽¹⁾	See 图 1 and 图 37	10		μs
$f_{(SCL)}$	SCL clock frequency			100	kHz
$t_{(BUF)}$	Bus free time between a STOP and START condition	See 图 1	4.7		μs
$t_{h(STA)}$	Hold time for (repeated) START condition		4		μs
$t_{(LOW)}$	Low period of SCL clock		4.7		μs
$t_{(HIGH)}$	High period of the SCL clock		4		μs
$t_{su(STA)}$	Setup time for a repeated START condition		4.7		μs
$t_{h(DAT)}$	Data hold time		0	3.45	μs
$t_{su(DAT)}$	Data setup time		250		ns
t_r	Rise time of both SDA and SCL signals	$C_{(b)}$ = total bus capacitance See 图 1		1000	ns
t_f	Fall time of both SDA and SCL signals			300	ns
$t_{su(STO)}$	Setup time for STOP condition	See 图 1	4		μs
$C_{(b)}$	Capacitive load for each bus line	$C_{(b)}$ = total capacitance of one bus line in pF		400	pF
$t_{d(SP)}$	Pulse duration of spikes that must be suppressed by the input filter		N/A	N/A	ns

(1) $V_{(SNSVDD/VREF)} \geq 1.6 \text{ V}$

6.7 Timing Requirements — I²C Fast Mode ($f_{(SCL)} = 400 \text{ kHz}$)

All specifications typical at -40°C to 125°C , $V_{(SNSVDD/VREF)} = V_{(I/OVDD)} = 1.6 \text{ V}$ to 3 V , unless otherwise noted.

			MIN	MAX	UNIT
$t_{(WL_RESET)}$	Reset low time ⁽¹⁾	See 图 1 and 图 37	10		μs
$f_{(SCL)}$	SCL clock frequency			400	kHz
$t_{(BUF)}$	Bus free time between a STOP and START condition	See 图 1	1.3		μs
$t_{h(STA)}$	Hold time for (repeated) START condition		0.6		μs
$t_{(LOW)}$	Low period of SCL clock		1.3		μs
$t_{(HIGH)}$	High period of the SCL clock		0.6		μs
$t_{su(STA)}$	Setup time for a repeated START condition		0.6		μs
$t_{h(DAT)}$	Data hold time		0	0.9	μs
$t_{su(DAT)}$	Data setup time		100		ns
t_r	Rise time of both SDA and SCL signals	$C_{(b)}$ = total bus capacitance See 图 1	$20 + 0.1 \times C_{(b)}$	300	ns
t_f	Fall time of both SDA and SCL signals ⁽²⁾		$20 + 0.1 \times C_{(b)}$	300	ns
$t_{su(STO)}$	Setup time for STOP condition	See 图 1	0.6		μs
$C_{(b)}$	Capacitive load for each bus line	$C_{(b)}$ = total capacitance of one bus line in pF		400	pF
$t_{d(SP)}$	Pulse duration of spikes that must be suppressed by the input filter		0	50	ns

(1) $V_{(SNSVDD/VREF)} \geq 1.6 \text{ V}$

(2) $C_{(b)}$ = the total capacitance of one bus line in pF. If using both fast-mode and Hs-mode devices, one may use faster fall times according to the [Timing Requirements — I²C High-Speed Mode \(\$f_{\(SCL\)} = 3.4 \text{ MHz}\$ \)](#) section. Note that the TSC2013-Q1 device is an Hs-mode device and follows the table requirements listed in the [Timing Requirements — I²C High-Speed Mode \(\$f_{\(SCL\)} = 3.4 \text{ MHz}\$ \)](#) section.

6.8 Timing Requirements — I²C High-Speed Mode ($f_{(SCL)} = 1.7 \text{ MHz}$)

All specifications typical at -40°C to 125°C , $V_{(SNSVDD/VREF)} = V_{(IOVDD)} =$ to 3 V, unless otherwise noted.

			MIN	MAX	UNIT
$t_{(WL_RESET)}$	Reset low time ⁽¹⁾	See 图 2 and 图 37	10		μs
$f_{(SCL)}$	SCL clock frequency			1.7	MHz
$t_{h(STA)}$	Hold time of (repeated) START condition	See 图 2	160		ns
$t_{(LOW)}$	Low period of SCL clock		320		ns
$t_{(HIGH)}$	High period of the SCL clock		120		ns
$t_{su(STA)}$	Setup time for a repeated START condition		160		ns
$t_{h(DAT)}$	Data hold time		0	150	ns
$t_{su(DAT)}$	Data setup time		10		ns
$t_{r(CL)}$	Rise time of SCL signal		20	80	ns
$t_{r(DA)}$	Rise time of SDA signal	20	160	ns	
$t_{f(CL)}$	Fall time of SCL signal	$C_{(b)}$ = total bus capacitance ⁽²⁾ 图 2	20	80	ns
$t_{f(DA)}$	Fall time of SDA signal		1	160	ns
$t_{r(CL1)}$	Rise time of SCL signal after a repeated START condition and after an acknowledge bit		20	160	ns
$t_{su(STO)}$	Setup time for STOP condition	See 图 2	160		ns
$C_{(b)}$	Capacitive load for each bus line	$C_{(b)}$ = total capacitance of one bus line in pF		400	pF
$t_{d(SP)}$	Pulse duration of spikes that must be suppressed by the input filter		0	10	ns

(1) $V_{(SNSVDD/VREF)} \geq 1.6 \text{ V}$

(2) For capacitive bus loads between 100 pF and 400 pF, interpolate the rise-time and fall-time values linearly.

6.9 Timing Requirements — I²C High-Speed Mode ($f_{(SCL)} = 3.4 \text{ MHz}$)

All specifications typical at -40°C to 125°C , $V_{(SNSVDD/VREF)} = V_{(IOVDD)} = 1.6 \text{ V}^{(1)}$ to 3 V, unless otherwise noted.

			MIN	MAX	UNIT
$t_{(WL_RESET)}$	Reset low time ⁽²⁾	See 图 2 and 图 37	10		μs
$f_{(SCL)}$	SCL clock frequency			3.4	MHz
$t_{h(STA)}$	Hold time for (repeated) START condition	See 图 2	160		ns
$t_{(LOW)}$	Low period of SCL clock		160		ns
$t_{(HIGH)}$	High period of the SCL clock		60		ns
$t_{su(STA)}$	Setup time for a repeated START condition		160		ns
$t_{h(DAT)}$	Data hold time		0	70	ns
$t_{su(DAT)}$	Data setup time		10		ns
$t_{r(CL)}$	Rise time of SCL signal		10	40	ns
$t_{r(DA)}$	Rise time of SDA signal	10	80	ns	
$t_{f(CL)}$	Fall time of SCL signal	$C_{(b)}$ = total bus capacitance ⁽³⁾ See 图 2	10	40	ns
$t_{f(DA)}$	Fall time of SDA signal		1	80	ns
$t_{r(CL1)}$	Rise time of SCL signal after a repeated START condition and after an acknowledge bit		10	80	ns
$t_{su(STO)}$	Setup time for STOP condition	See 图 2	160		ns
$C_{(b)}$	Capacitive load for each bus line	$C_{(b)}$ = total capacitance of one bus line in pF		100	pF
$t_{d(SP)}$	Pulse duration of spikes that must be suppressed by the input filter		0	10	ns

(1) Because of the low supply voltage of 1.2 V and the wide temperature range of -40°C to 125°C , the I²C system devices may not reach the maximum specification of I²C high-speed mode, and $f_{(SCL)}$ may not reach 3.4 MHz.

(2) $V_{(SNSVDD/VREF)} \geq 1.6 \text{ V}$

(3) Capacitive load from 10 pF to 100 pF.



图 1. Detailed I/O Timing for Standard and Fast Modes



(1) The First rising edge of the SCL signal after Sr and after each acknowledge bit.

图 2. Detailed I/O Timing for High-Speed Mode

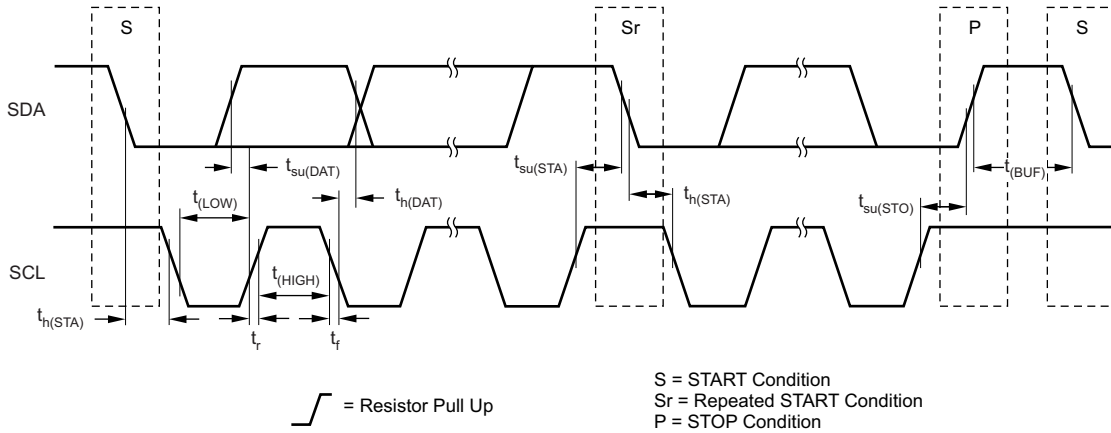
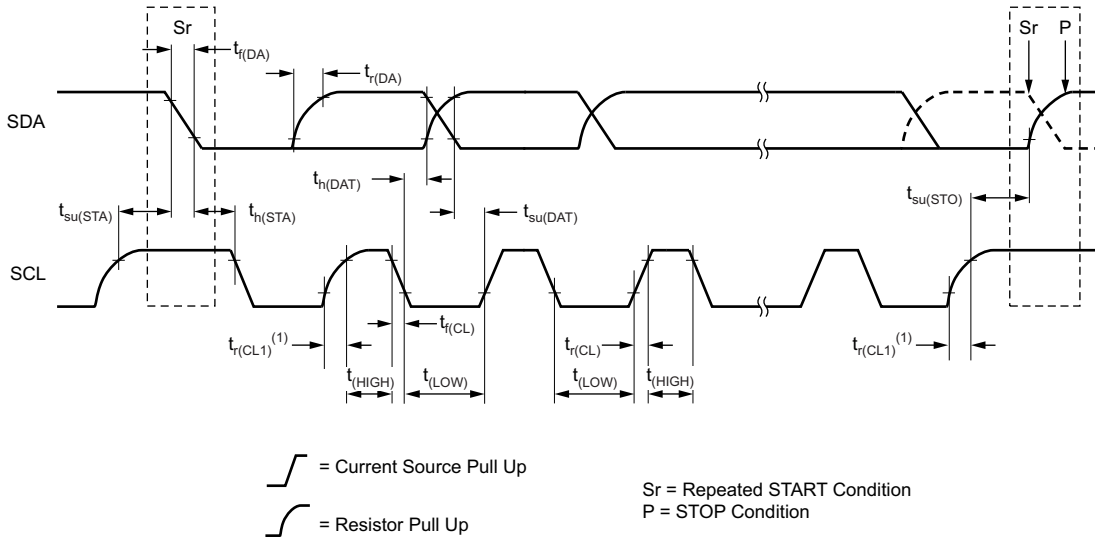
6.10 Typical Characteristics

At $T_A = -40^\circ\text{C}$ to 125°C , $V_{\text{SNSVDD}}/V_{\text{REF}} = 1.6\text{ V}$ to 3 V , $I_{\text{OVDD}} = 1.2\text{ V}$ to $V_{\text{SNSVDD}}/V_{\text{REF}}$, $f_{\text{(ADC)}} = f_{\text{(OSC)}} / 2$, high-speed mode ($f_{\text{(SCL)}} = 3.4\text{ MHz}$), 12-bit mode, and non-continuous AUX measurement, unless otherwise noted.

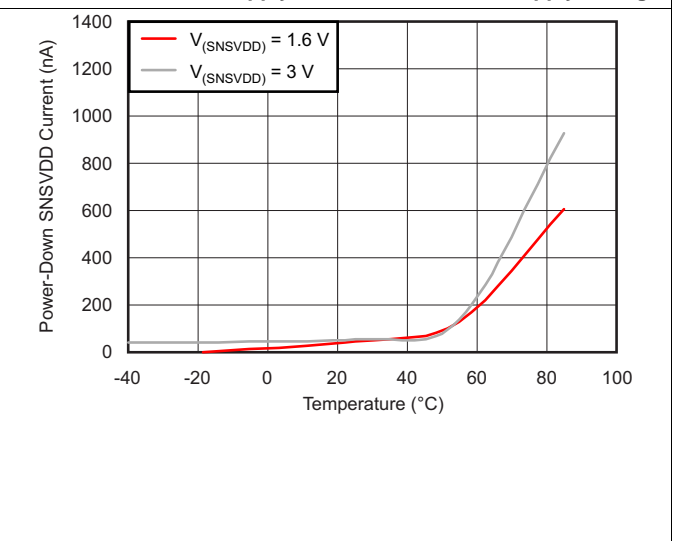
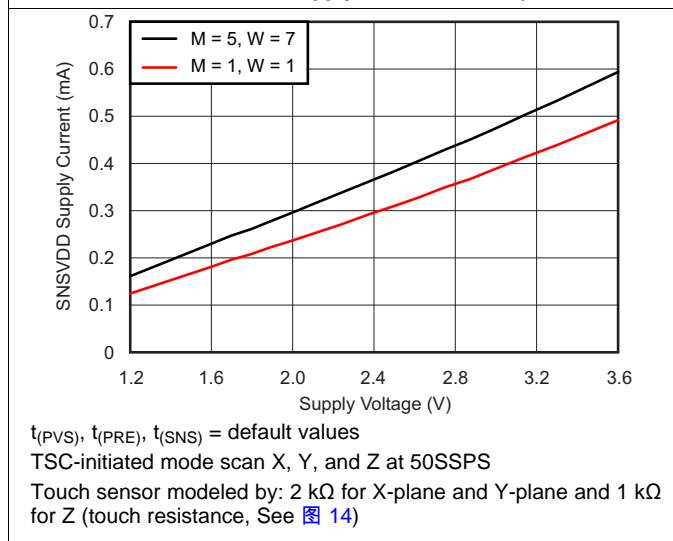
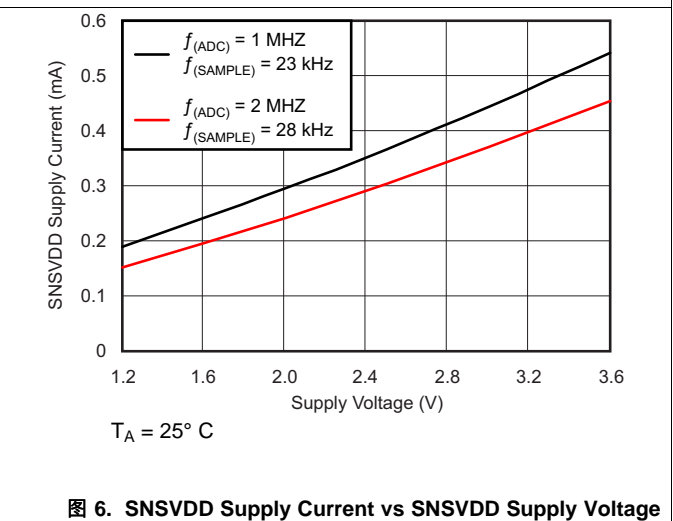
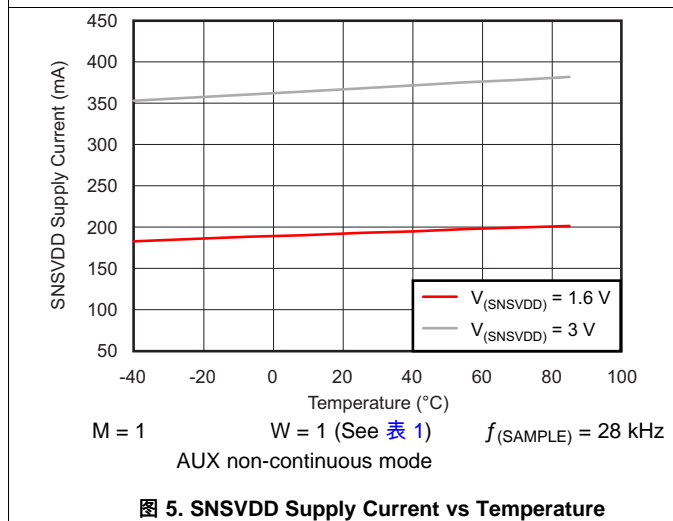
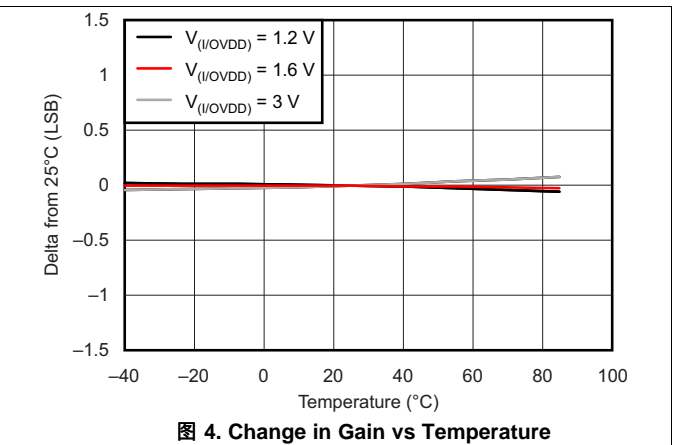
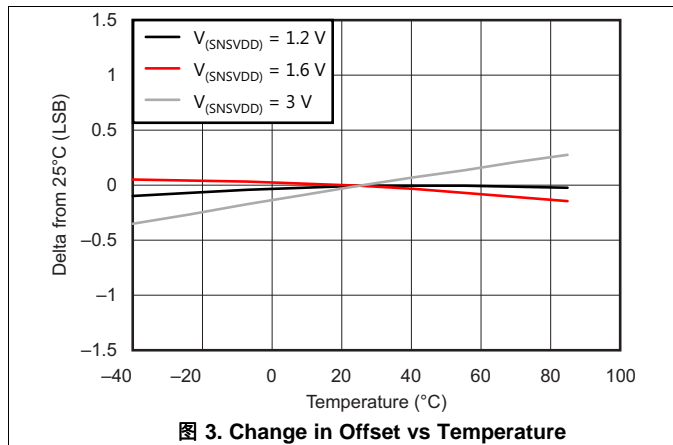

Typical Characteristics (接下页)

At $T_A = -40^{\circ}\text{C}$ to 125°C , $\text{SNSVDD}/\text{VREF} = 1.6\text{ V}$ to 3 V , $\text{I/OVDD} = 1.2\text{ V}$ to $\text{SNSVDD}/\text{VREF}$, $f_{(\text{ADC})} = f_{(\text{OSC})} / 2$, high-speed mode ($f_{(\text{SCL})} = 3.4\text{ MHz}$), 12-bit mode, and non-continuous AUX measurement, unless otherwise noted.



图 9. Power-Down Supply Current vs Supply Voltage



图 10. I/OVDD Supply Current vs Temperature

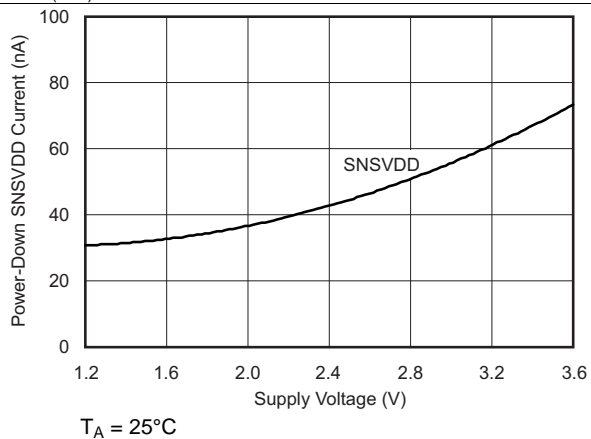

图 11. I/OVDD Supply Current vs I/OVDD Supply Voltage

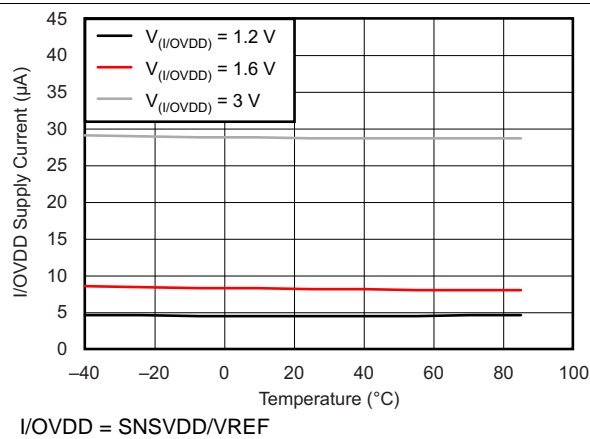

图 12. Reference Input Current vs Temperature

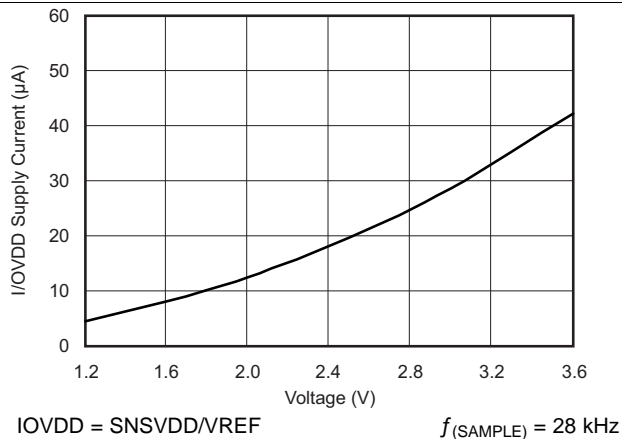

图 13. Reference Input Current vs SNSVDD Supply Voltage

7 Detailed Description

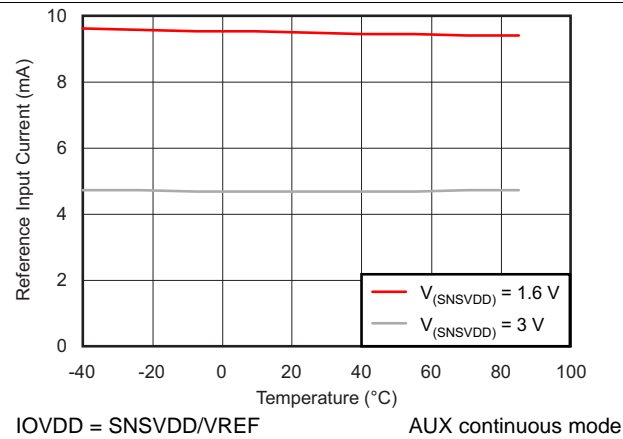
7.1 Overview

The TSC2013-Q1 device is an analog interface circuit for a human-interface touch-screen device. A register-based architecture eases integration with microprocessor-based systems through a standard I²C bus. Registers and onboard state machines control all peripheral functions. The TSC2013-Q1 features include:

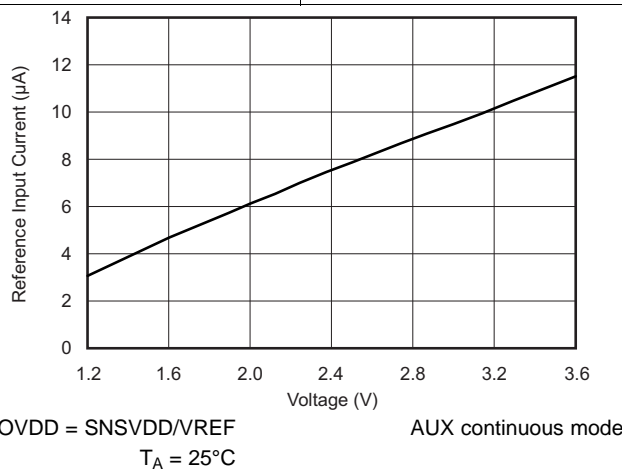
- Very low-power touch-screen controller
- Very small onboard footprint
- Flexible preprocessing which relieves the host from tedious routine tasks and saves resources for more critical tasks
- Ability to work on very low supply voltage
- Minimal connection interface allows easiest isolation and reduces the number of dedicated I/O pins required
- Enhanced ESD protection
- Panel-current sensing
- Miniature device, yet complete; requires no external supporting components

注

Although the TSC2013-Q1 device can use an external reference, the SNSVDD/VREF pin can also be used as the reference.

The TSC2013-Q1 device consists of the following blocks (see the [Functional Block Diagram](#) section):

- Touch-screen interface
- Auxiliary input (AUX)
- Acquisition-activity preprocessing
- Internal conversion clock
- I²C interface

Communication with the TSC2013-Q1 device is through an I²C serial interface. The TSC2013-Q1 device is an I²C slave device. Therefore, data shifts into or out of the TSC2013-Q1 device under the control of the host microprocessor, which also provides the serial data clock.

Writing to different registers in the TSC2013-Q1 device controls the TSC2013-Q1 device and device functions. The use of a simple command protocol (compatible with I²C) addresses these registers. This protocol can be an I²C write-address followed by multiple control bytes, or multiple combinations of control and data bytes for writing into different registers (two bytes each). To read from registers, write an I²C read-address to the TSC2013-Q1 device, followed by one or multiple sequential reads from the registers.

The host writes the address of the register to be read in control byte 0 with the register address and read-bit (as described in the previous paragraph). The register address serves as a pointer to the register map where the first read starts. This designated register address is static and a write to a register address does not need to occur again unless a new register address has overwritten it or after a TSC2013-Q1 reset (by a software reset or by the RESET pin).

The touch-measurement result goes into the TSC2013-Q1 registers, from which the host may read it at any time. This preprocessing frees up the host in order to allocate resources to more-critical tasks. Two optional signals are also available from the TSC2013-Q1 device to indicate that data are available for the host to read. The PINTDAV pin is a programmable interrupt or status output pin. With the PINTDAV pin programmed as a DAV output, the pin indicates that an ADC conversion has completed and that data are available. With the PINTDAV pin programmed as a PENIRQ output, the pin indicates the detection of a touch on the touch screen. The status register of the TSC2013-Q1 device provides an extended status reading, including the state of the DAV and PENIRQ outputs, without the cost of any dedicated pin. See [Figure 14](#) for a typical application of the TSC2013-Q1 device.

To detect two touches, add an external R_(SENSE) resistor as shown in [Figure 14](#). The value of R_(SENSE) depends on the touch-panel resistance. The ratio between the lowest touch-panel resistance and R_(SENSE) should be approximately 4.5.

Overview (接下页)



图 14. Typical Circuit Configuration

7.2 Functional Block Diagram

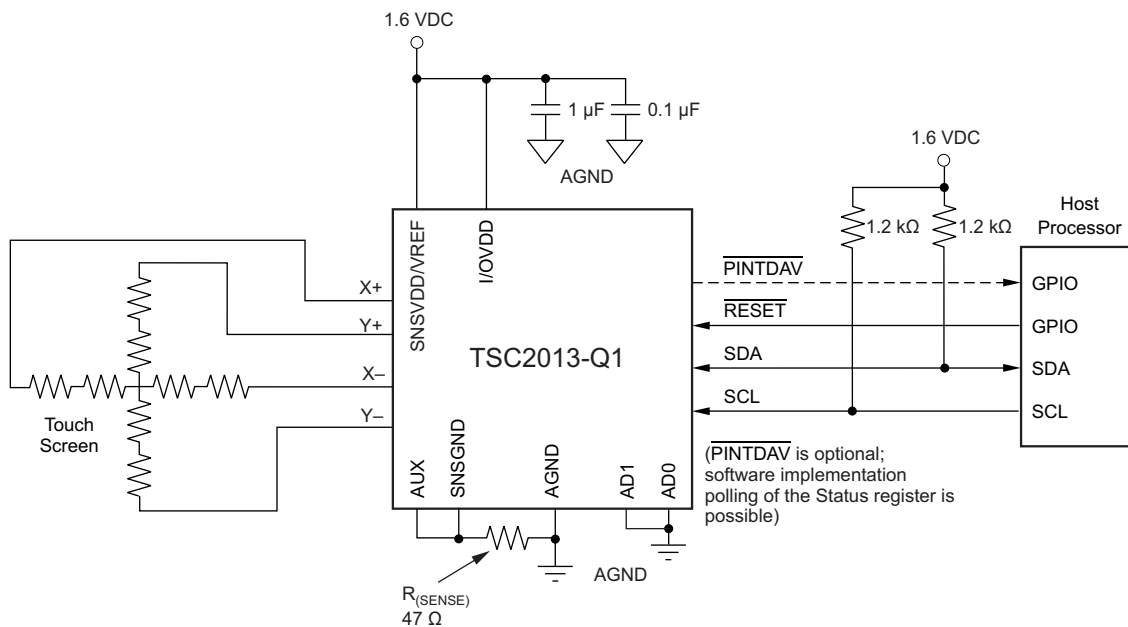
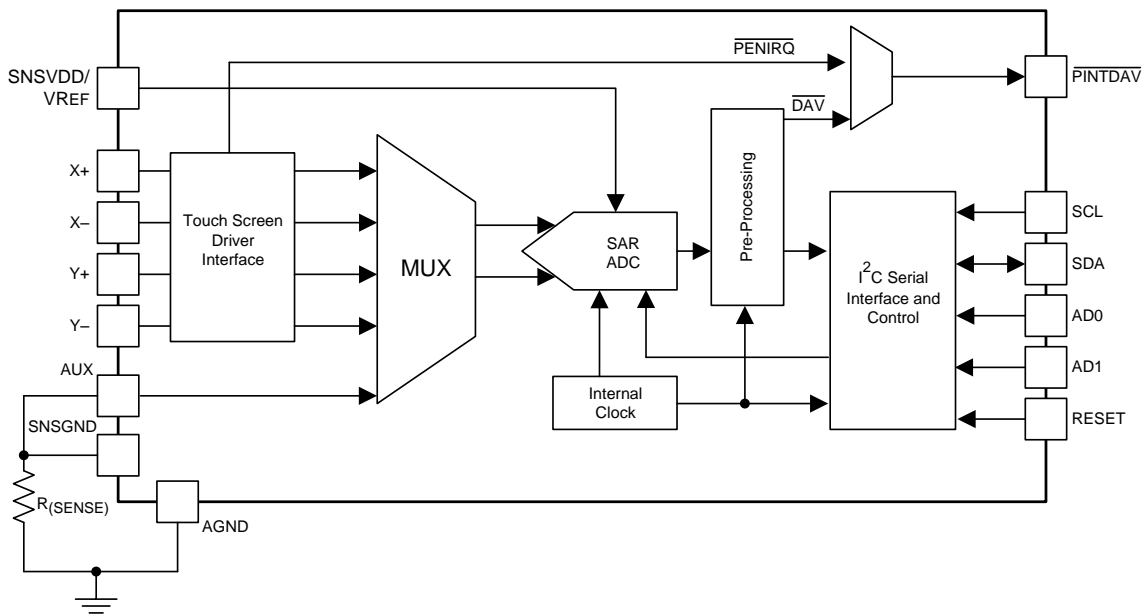

7.3 Feature Description

7.3.1 Touch-Screen Operation

A resistive touch screen operates by applying a voltage across a resistor network and measuring the change in resistance at a given point on the matrix where an input (stylus, pen, or finger) touches the screen. The change in the resistance ratio marks the location on the touch screen.

The TSC2013-Q1 device supports resistive 4-wire configurations as shown in [图 15](#). The circuit determines location in two coordinate-pair dimensions, although addition of a third dimension for measuring pressure is possible.

7.3.2 4-Wire Touch Screen Measurements

[图 15](#) shows construction of a typical four-wire touch screen. The screen consists of two transparent resistive layers separated by insulating spacers.



图 15. Four-Wire Touch Screen Construction

The four-wire touch-screen panel works by applying a voltage across the vertical or horizontal resistive network.

To determine a touch location, the TSC2013-Q1 device provides a set of eight data measurements (X1, X2, IX, Y1, Y2, IY, Z1, and Z2). [图 17](#) through [图 19](#) show the internal ADC configurations. Taking an X1 measurement involves activating the X+ and X- drivers and digitizing the voltage at Y+. The $R_{(SENSE)}$ resistor must be connected as shown in [图 14](#). The SNSGND and AUX pins connect to one end of $R_{(SENSE)}$, and the other end connects to the AGND pin.

The TSC2013-Q1 device can also measure touch pressure (Z). To determine a pen or finger touch, determination of the pressure of the *touch* is required. Generally, having very high performance for this test is not necessary. Therefore, TI recommends 10-bit resolution mode. Several different ways of performing this measurement are available. The TSC2013-Q1 device supports two methods. The first method requires knowing the X-plate resistance, the measurement of X1, and two additional cross-panel measurements (Z2 and Z1) of the touch screen (see [图 16](#)). [公式 1](#) calculates the touch resistance ($R_{(TOUCH)}$).

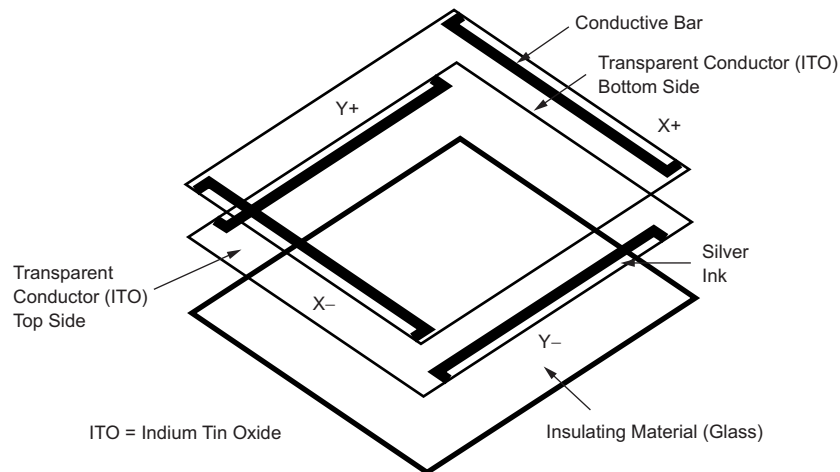
$$R_{(TOUCH)} = R_{X(PLATE)} \times \frac{X1}{4096} \times \left(\frac{Z2}{Z1} - 1 \right) \quad (1)$$

The second method requires knowing both the X-plate and Y-plate resistance, and the measurement of X1, Y1, and Z1. [公式 2](#) also calculates the touch resistance.

$$R_{(TOUCH)} = \frac{R_{X(PLATE)}}{4096} \left(\frac{4096}{Z1} - 1 \right) - R_{Y(PLATE)} \times \left(1 - \frac{Y1}{4096} \right) \quad (2)$$

Feature Description (接下页)



图 16. Pressure Measurement

Feature Description (接下页)

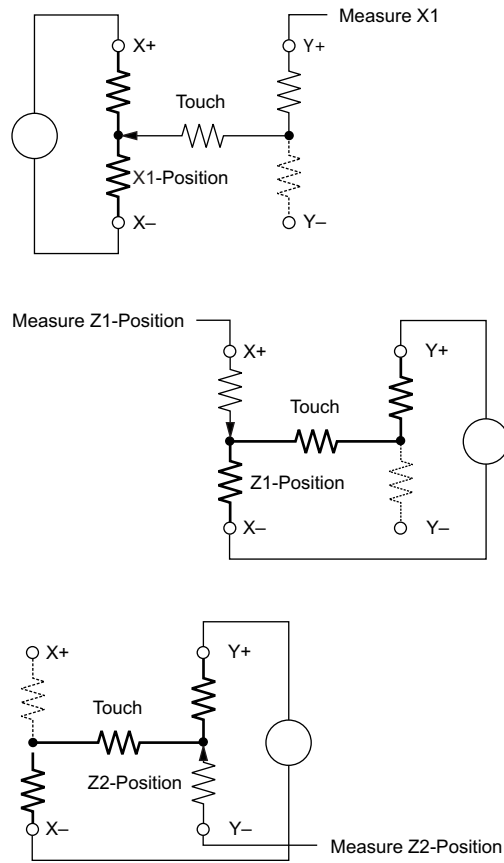

图 17. X-Coordinate Differential-Triplet Measurement (X1, X2, I_x)

Feature Description (接下页)



图 18. Y-Coordinate-Differential-Triplet Measurement (Y1, Y2, IY)

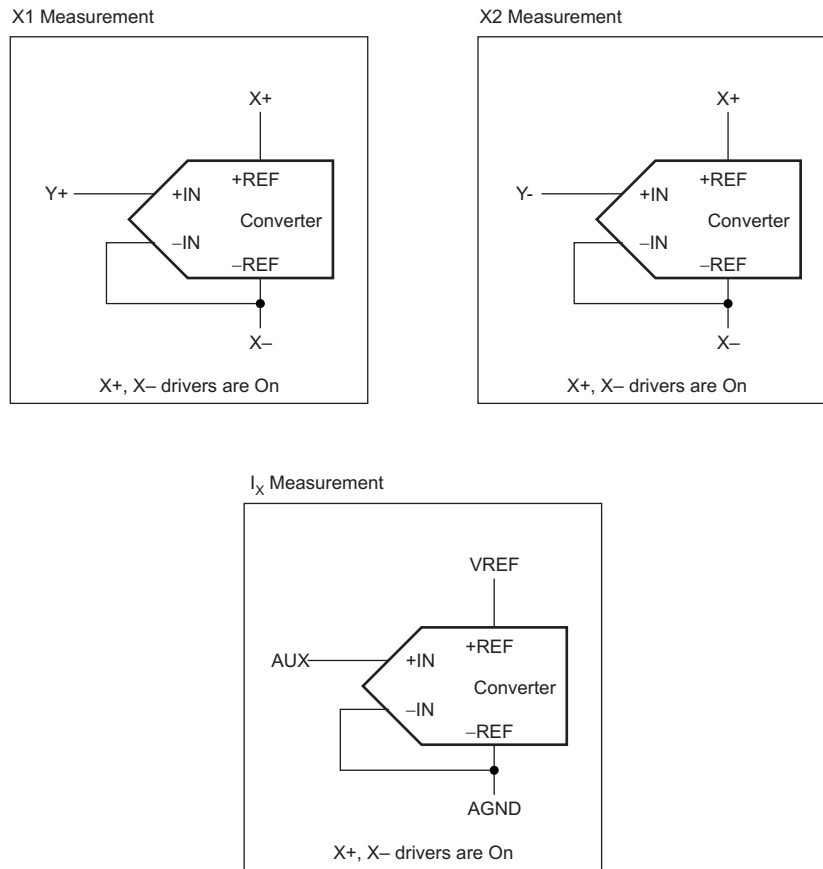

图 19. Z-Measurement (Z1, Z2)

When touching or pressing the touch panel with the drivers to the panel turned on, the voltage across the touch panel often overshoots and then slowly settles down (decays) to a stable DC value. This effect is a result of mechanical bouncing caused by vibration of the top-layer sheet of the touch panel when pressing the panel. Without accounting for this settling time, the converted value is in error. Therefore, introducing a delay between the time the driver for a particular measurement is turned on and the time a measurement is made is necessary.

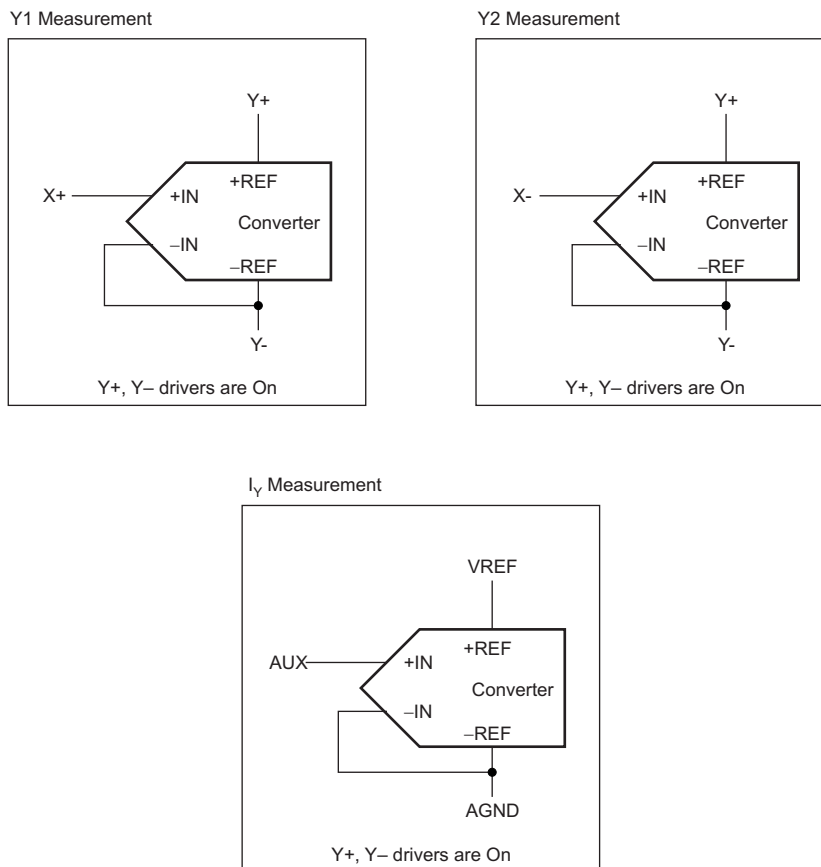
Feature Description (接下页)

In some applications, external capacitors may be required across the touch screen for filtering noise picked up by the touch screen (such as noise generated by the LCD panel or back-light circuitry). The value of these capacitors provides a low-pass filter to reduce noise, but causes an additional settling-time requirement when the panel is touched.

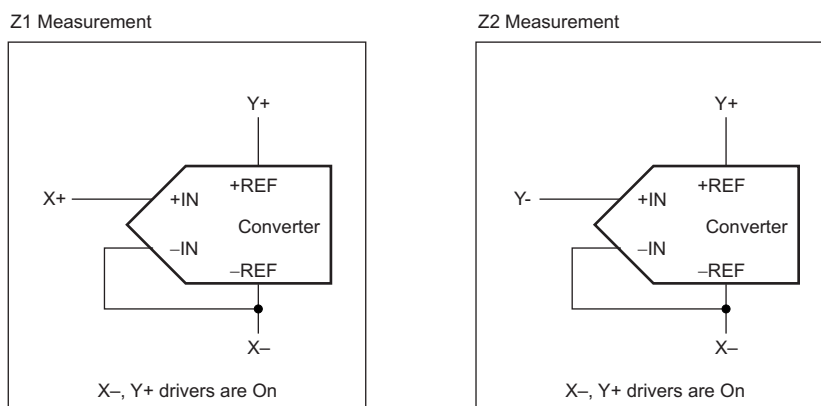
The TSC2013-Q1 device offers several solutions to this problem. A programmable delay time is available that sets the delay between turning the drivers on and making a conversion. The TSC2013-Q1 device uses this delay, referred to as the *panel voltage-stabilization time*, in some of the device modes. In other modes, commands can cause the TSC2013-Q1 device to turn on the drivers only without performing a conversion. Issuing the command to perform a conversion occurs after allowing sufficient stabilization time.

The TSC2013-Q1 touch-screen interface can measure different data sets. Determination of these measurements is possible under three different modes of the ADC:

- TSMODE1: conversion controlled by the TSC2013-Q1 device and initiated by the touchscreen controller (TSC)
- TSMODE2: conversion controlled by the TSC2013-Q1 device and initiated by the host responding to the PENIRQ signal
- TSMODE3: conversion completely controlled by the host processor

7.3.3 Analog-to-Digital Converter

图 20 shows the analog inputs of the TSC2013-Q1 device. A multiplexer provides the analog inputs (X, Y, and Z touch panel coordinates and auxiliary inputs) to the successive-approximation register (SAR) analog-to-digital converter (ADC). The basis of ADC architecture is capacitive redistribution architecture, which inherently includes a sample-and-hold function.

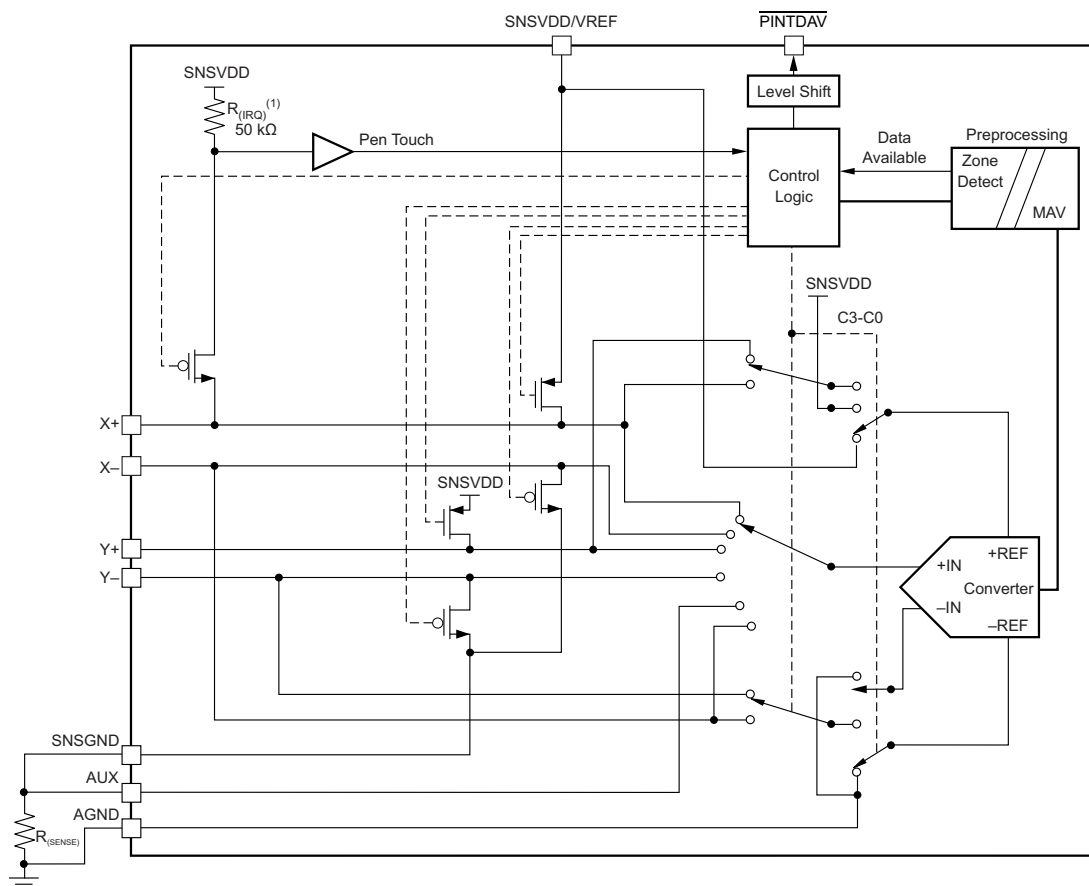

(1) Untrimmed resistor; see the typical value in the table.

图 20. Simplified Diagram of the Analog Input Section

Feature Description (接下页)

A unique configuration of low on-resistance switches allows an unselected ADC input channel to provide power and an accompanying pin to provide ground for driving the touch panel. By maintaining a differential input to the converter and a differential reference input architecture, negating errors caused by the on-resistance of the driver switches is possible.

Two ADC-control registers control the ADC. Several modes of operation are possible, depending on the bits set in the control registers. Programming of channel selection, scan operation, preprocessing, resolution, and conversion rate is through these registers. The following sections outline these modes for each type of analog input. The appropriate result register stores the conversion results.

7.3.3.1 Data Format

The TSC2013-Q1 output data are in straight binary format as shown in 图 21. 图 21 shows the ideal output code for the given input voltage and does not include the effects of offset, gain, or noise.

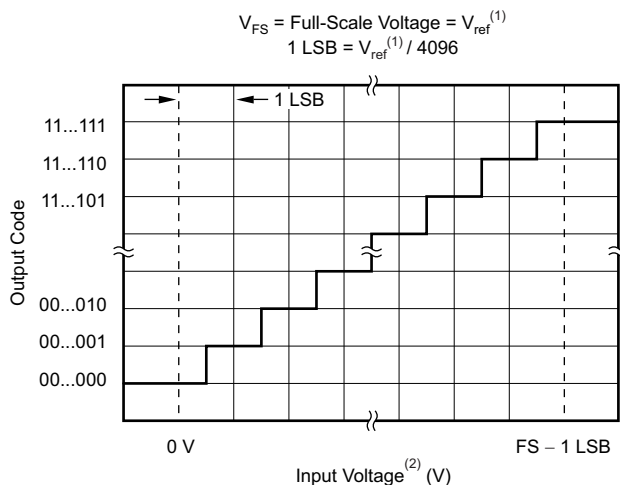

(1) Reference voltage at converter: +REF – (–REF). See 图 20.

(2) Input voltage at converter, after multiplexer: +IN – (–IN). See 图 20.

图 21. Ideal Input Voltages and Output Codes

7.3.3.2 Reference

The TSC2013-Q1 device uses an external voltage reference applied to the SNSVDD/VREF pin. Using the SNSVDD/VREF pin as the reference voltage is possible because the upper reference voltage range is the same as the supply-voltage range.

7.3.3.3 Variable Resolution

The TSC2013-Q1 device provides either 10-bit or 12-bit resolution for the ADC. Lower resolution is often practical for measuring slow-changing signals such as touch pressure. Performing the conversions at lower resolution reduces the amount of time required for the ADC to complete the conversion process which also lowers power consumption.

7.3.3.4 Conversion Clock and Conversion Time

The TSC2013-Q1 device contains an internal clock (oscillator) that drives the internal state machines that perform the many functions of the part. This clock is divided down to provide a conversion clock for the ADC. The setting for the division ratio of this clock is in the ADC control register (see [Configuration Register 0 \(address = 0\) \[reset = 4000h for read; 0000h for write\]](#)). The ability to change the conversion clock rate allows the user to select the optimal values for resolution, speed, and power dissipation. Using the 4-MHz (oscillator) clock directly as the ADC clock (when the CL[1:0] bit is set to 0) limits the ADC resolution to 10 bits. Using higher resolutions at this speed does not result in more accurate conversions. Twelve-bit resolution requires that the CL bits 1 and 0 are set to 0 and 1, or 1 and 0 (respectively).

Feature Description (接下页)

Regardless of the conversion clock speed, the internal clock runs nominally at 3.8 MHz at a 3-V supply (SNSVDD) and slows down to 3.6 MHz at a 1.6-V supply. The conversion time of the TSC2013-Q1 device depends on several functions. The conversion clock speed plays an important role in the time required for a conversion to complete. However, proper sampling of the signal requires a certain number of internal clock cycles. Moreover, additional times (such as the panel voltage-stabilization time), can add significantly to the time it takes to perform a conversion. Conversion time can vary depending on the mode of use of TSC2013-Q1 device. This data sheet makes use of internal and conversion clock cycles throughout as the units used to describe the amount of time that many functions take. Take these times into account when considering the total system design.

7.3.3.5 Touch Detect

The $\overline{\text{PINTDAV}}$ pin can be programmed to generate an interrupt to the host. 图 22 shows an example for a typical screen-touch situation. While in the power-down mode, the Y– driver is on and connects to GND. The internal pen-touch signal depends on whether or not the X+ input is low. A touch on the panel pulls the X+ input to ground through the touch screen and sets the internal pen-touch output to low because of the detection on the current path through the panel to ground, which initiates an interrupt to the processor. During the measurement cycles for X and Y-position, the device disconnects the X+ input, which eliminates any leakage current from the pull-up resistor flowing through the touch screen, thus causing no errors.

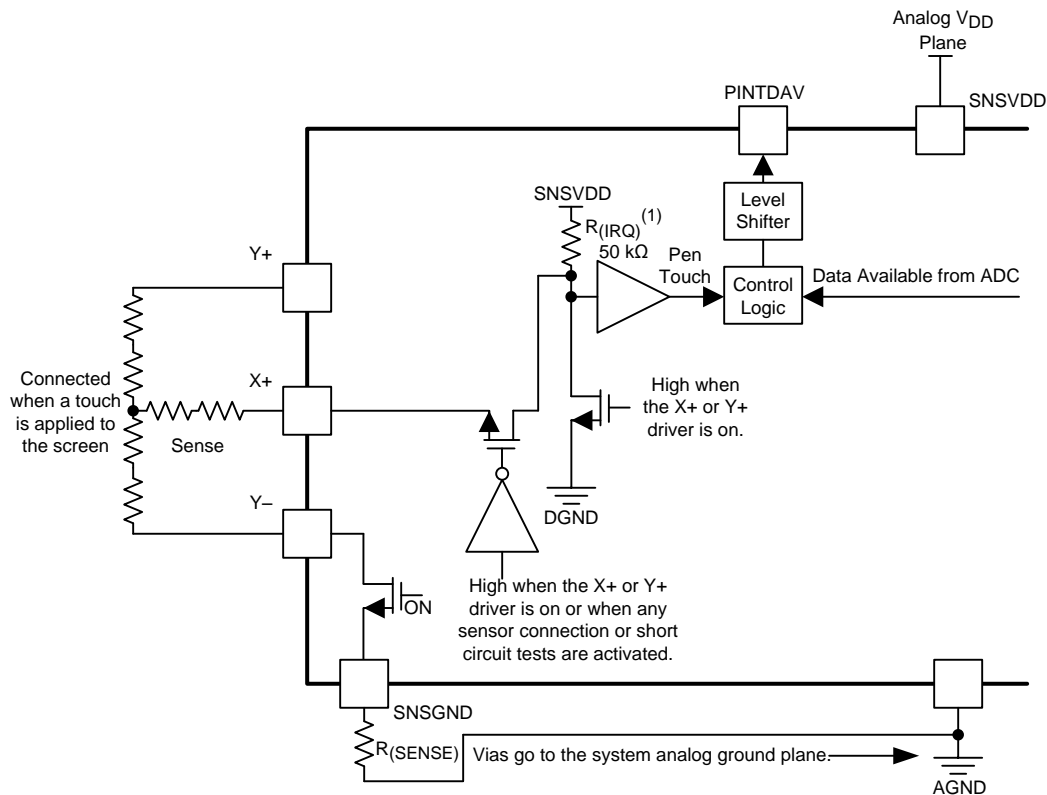

(1) Untrimmed resistor; see the typical value in the table.

图 22. Example of a Pen-Touch Induced Interrupt via the $\overline{\text{PINTDAV}}$ Pin

Feature Description (接下页)

In modes where the TSC2013-Q1 device must detect whether or not a touch remains on the screen (for example, when doing a pen-touch-initiated X, Y, and Z conversion), the TSC2013-Q1 device must reset the drivers to connect the $R_{(IRQ)}$ resistor again. Because of the high value of this pullup resistor, any capacitance on the touch screen inputs causes a long delay time, and may prevent the detection from occurring correctly. To prevent this possible delay, the TSC2013-Q1 device has a circuit that allows *precharging* any screen capacitance, so that the pullup resistor must not be the only source for the charging current. The setting for the time allowed for this precharge, as well as the time needed to sense if the screen touch remains, is in the configuration register.

This configuration underscores the need to use the minimum possible capacitor values on the touch-screen inputs. Capacitors can be used to reduce noise, but capacitors with too large a value increase the required precharge and sense times, as well as the panel voltage-stabilization time.

7.3.3.6 Preprocessing

The TSC2013-Q1 device offers an array of powerful preprocessing operations that reduce unnecessary traffic on the bus and reduce the host processor loading. This reduction is especially critical for the serial interface because of the slow bus speed and the high CPU bandwidth required for I²C communication.

All data-acquisition tasks are looking for specific data that meet certain criteria. Many of these tasks fall into a predefined range, while other tasks may be looking for a value in a noisy environment. If the host processor is to retrieve all these data for processing, the limited bus bandwidth quickly saturates, along with the host processor processing capability. In any case, reserving the host processor for more critical tasks rather than routine work is always necessary.

The preprocessing unit consists of two main functions which result in the combined MAV (median and averaging-value) filter: the median value filter (MVF) and the averaging-value filter (AVF).

7.3.3.6.1 Preprocessing—Median Value Filter and Averaging Value Filter

The first preprocessing function, a combined MAV filter, can operate independently as a median value filter (MVF), an averaging value filter (AVF), and a combined filter (MAV filter).

If the acquired signal source is noisy because of the digital switching circuit, evaluating the data without noise may be necessary. In this case, the median value filter (MVF) operation helps to discard noise. The first action is sorting the array of N converted results. The return value is either the middle (median value) of an array of M converted results, or the average value of a window size of W of converted results:

N = the total number of converted results used by the MAV filter

M = the median value filter size programmed

W = the averaging window size programmed

If M is equal to 1, then N is equal to W . A special case is W equal to 1, which indicates a bypassed MAV filter. Otherwise, if W is greater than 1, averaging is the only function performed on these converted results. In either case, the return value is the averaged value of window size W of converted results.

If M is greater than 1 and W is equal to 1, then N is equal to M , meaning the only operating filter is the median value filter. The return value is the middle position converted result from the array of M converted results.

If M is greater than 1 and W is greater than 1, then N is equal to M . In this case, W is less than M . The return value is the averaged value of middle portion W of converted results out of the array of M converted results. Because the value of W is an odd number in this case, the calculation of the averaging value counts the middle-position converted result twice (averaging a total of $W + 1$ converted results).

Feature Description (接下页)

表 1. Median Value Filter-Size Selection

M1	M0	MEDIAN VALUE FILTER M =	POSSIBLE AVERAGING WINDOW SIZE W =
0	0	1	1, 4, 8, 16
0	1	3	1
1	0	7	1, 3
1	1	15	1, 3, 7

表 2. Averaging Value Filter-Size Selection

W1	W0	AVERAGING VALUE FILTER SIZE SELECTION W =	
		M = 1 (Averaging Only)	M > 1
0	0	1	1
0	1	4	3
1	0	8	7
1	1	16	Reserved

The device uses the default MVF setting (median value filter with averaging bypassed) for any invalid MAV filter configuration. For example, if M1, M0, W1, and W0 equals 1, 0, 1, and 0 (respectively), the MAV filter will perform as if it were configured for 1, 0, 0, 0, median filter only with filter size of 7, and no averaging. The only exception is when M is greater than 1 and when W1 and W0 equal 1. Avoid using this reserved setting.

表 3. Combined MAV Filter Setting

M	W	INTERPRETATION	N =	OUTPUT
= 1	= 1	Bypass both MAF and AVF	W	The converted result
= 1	> 1	Bypass MVF only	W	Average of W converted results
> 1	= 1	Bypass AVF only	M	Median of M converted results
> 1	> 1	M > W	M	Average of middle W of M converted results with the median counted twice

The MAV filter is available for all analog inputs including the touch-screen inputs and the AUX measurement.



图 23. MAV Filter Operation

7.4 Device Functional Modes

7.4.1 Conversion Controlled by TSC2013-Q1 and Initiated by TSC2013-Q1 (TSMODE 1)

In TSMODE 1, before a pen-touch detection is possible, the TSC2013-Q1 device must be programmed with the PSM bit set to 1 and one of two scan modes:

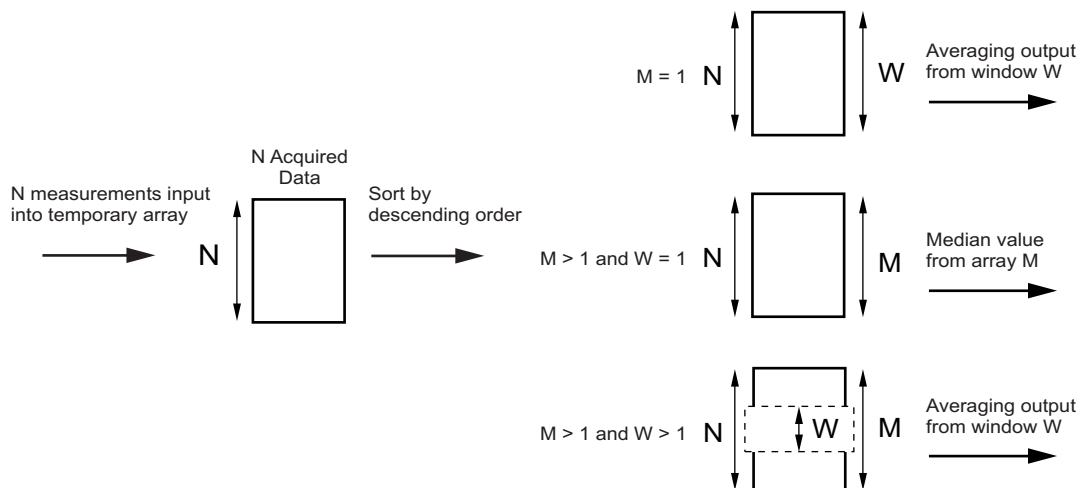
1. X-triplet, Y-triplet, Z-scan (converter function select bits C[3:0] = control byte 1 D[6:3] = 0000)
2. IX-IY scan (converter function select bits C[3:0] = control byte 1 D[6:3] = 0001).

See [表 7](#) for more information on the converter function-select bits.

On touching the touch panel, the internal pen-touch signal activates, lowering the $\overline{\text{PINTDAV}}$ output if programmed as $\overline{\text{PENIRQ}}$. The TSC2013-Q1 device then executes the preprogrammed scan function without a host intervention.

7.4.1.1 IX-IY Scan

The TSC2013-Q1 device starts up the internal clock. The device then turns on the Y-drivers, and after a programmed panel voltage-stabilization time, the device powers up the ADC and converts the IY coordinate. With preprocessing selected, several conversions can occur. When data preprocessing is complete, a temporary register stores the IY coordinate result.

If the screen touch remains at this time, the device enables the X-drivers and the process repeats but measures the IX coordinate instead, storing the result in a temporary register.

[图 24](#) shows a flowchart for this process. The time required to go through this process depends on the selected resolution, internal conversion clock rate, panel voltage-stabilization time, precharge and sense times, and the selection status of preprocessing. Use [公式 3](#) to calculate the time required to achieve a complete X and Y coordinate (sample set) reading.

$$t_{(\text{COORDINATE})} = \frac{t_{(\text{OH1})}}{f_{(\text{OSC})}} + 2 \times \left(t_{(\text{PVS})} + t_{(\text{PRE})} + t_{(\text{SNS})} + \frac{t_{d(\text{OH1})}}{f_{(\text{OSC})}} \right) + 2 \times \left(N \times \left[(B + 2) \times \frac{f_{(\text{OSC})}}{f_{(\text{ADC})}} + t_{c(\text{OH})} \right] \times \left[\frac{1}{f_{(\text{OSC})}} \right] + \left[\frac{t_{(\text{PPRO})}}{f_{(\text{OSC})}} \right] \right)$$

where

- $t_{(\text{COORDINATE})}$ = time to complete IX and IY coordinate reading
- N = number of measurements for MAV filter input, as given in [表 3](#) as N
(For no MAV: M1 = M0 = W1 = W0 = 0)
- $t_{(\text{PVS})}$ = panel voltage stabilization time, as listed in [表 11](#)
- $t_{(\text{PRE})}$ = precharge time, as listed in [表 11](#)
- $t_{(\text{SNS})}$ = sense time, as listed in [表 11](#)
- B = number of bits of resolution
- $f_{(\text{OSC})}$ = TSC onboard OSC clock frequency. See the [Electrical Characteristics](#) section for supply frequency (SNSVDD)
- $f_{(\text{ADC})}$ = ADC clock frequency, as listed in [表 11](#)
- $t_{(\text{OH1})}$ = overhead time number 1 = 2.5 internal clock cycles
- $t_{d(\text{OH1})}$ = total overhead time for $t_{(\text{PVS})}$, $t_{(\text{PRE})}$, and $t_{(\text{SNS})}$ = 10 internal clock cycles
- $t_{c(\text{OH})}$ = total overhead time for A-to-D conversion = 3 internal clock cycles
- $t_{(\text{PPRO})}$ = preprocessor preprocessing time as listed in [表 4](#)

(3)

表 4. Preprocessing Delay

M =	W =	$t_{(\text{PPRO})}$ =	
		FOR B = 12 BIT	FOR B = 10 BIT
1	1, 4, 8, 16	2	2
3, 7	1	28	24
7	3	31	27
15	1	31	29
15	3	34	32
15	7	38	36



图 24. Example of an IX and IY Touch-Screen Scan Using TSMODE 1

7.4.1.2 X-Triplet, Y-Triplet, Z-Scan

The TSC2013-Q1 device starts up the internal clock. The device then turns on the Y-drivers, and after a programmed panel voltage-stabilization time, powers up the ADC and converts the Y-triplet. With preprocessing selected, several conversions can occur. When data preprocessing is complete, temporary registers store the Y-triplet results.

If the screen touch remains at this time, the device enables the X-drivers and the process repeats but measures the X-triplet instead, storing the result in temporary registers.

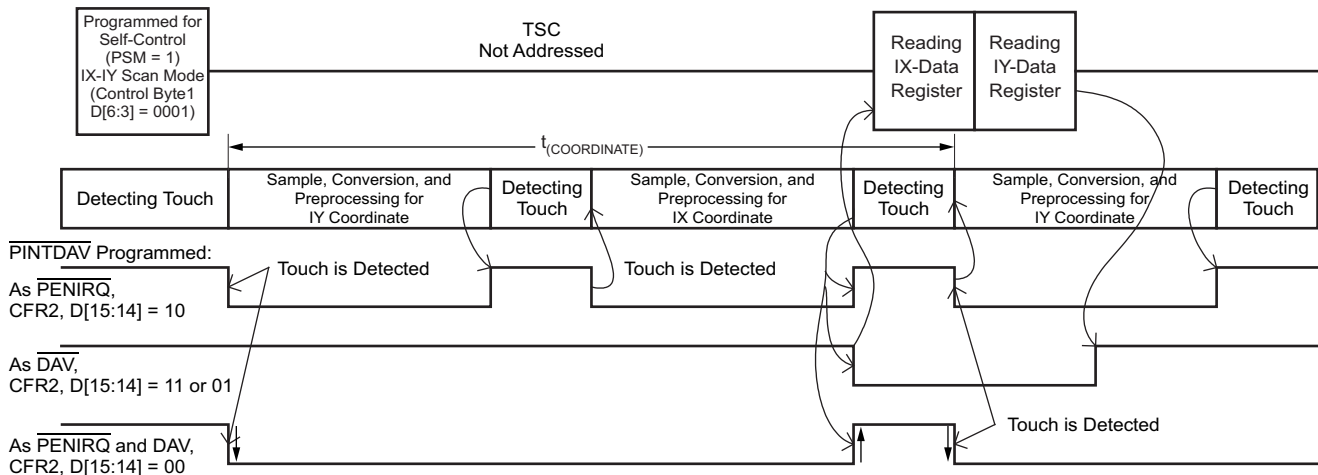
The process continues in the same way, but measures the Z1 and Z2 values instead, storing the results in temporary registers. When the complete sample set of data (X1, X2, IX, Y1, Y2, IY, Z1, and Z2) are available, the device loads the data in the X1, X2, IX, Y1, Y2, IY, Z1, and Z2 registers. 图 25 shows this process. This process time depends on the previously described settings. Use 公式 4 to calculate the time for a complete X1, X2, IX, Y1, Y2, IY, Z1, and Z2 coordinate reading.

$$t_{(COORDINATE)} = \frac{t_{(OH2)}}{f_{(OSC)}} + 3 \times \left(t_{(PVS)} + t_{(PRE)} + t_{(SNS)} + \frac{t_{d(OH1)}}{f_{(OSC)}} \right) + 8 \times \left(N \times \left[(B + 2) \times \frac{f_{(OSC)}}{f_{(ADC)}} + t_{c(OH)} \right] \times \left[\frac{1}{f_{(OSC)}} \right] + \left[\frac{t_{(PPRO)}}{f_{(OSC)}} \right] \right)$$

where

- $t_{(OH2)}$ = overhead time number 2 = 3.5 internal clock cycles (4)



图 25. Example of an X-Triplet and Y-Triplet Coordinate Touch-Screen Scan Using TSMODE 1

7.4.2 Conversion Controlled by TSC2013-Q1 and Initiated by Host (TSMODE 2)

In TSMODE 2, the TSC2013-Q1 device detects when a touch of the touch panel occurs and causes the internal pen-touch signal to activate, which lowers the PINTDAV output if programmed as PENIRQ. The host recognizes the interrupt request and then writes to the ADC control register to select one of the following two Touch-Screen Scan functions:

1. X-triplet, Y-triplet, Z-scan (converter function select bits C[3:0] = control byte 1 D[6:3] = 0000); or
2. IX-IY scan (converter function select bits C[3:0] = control byte 1 D[6:3] = 0001).

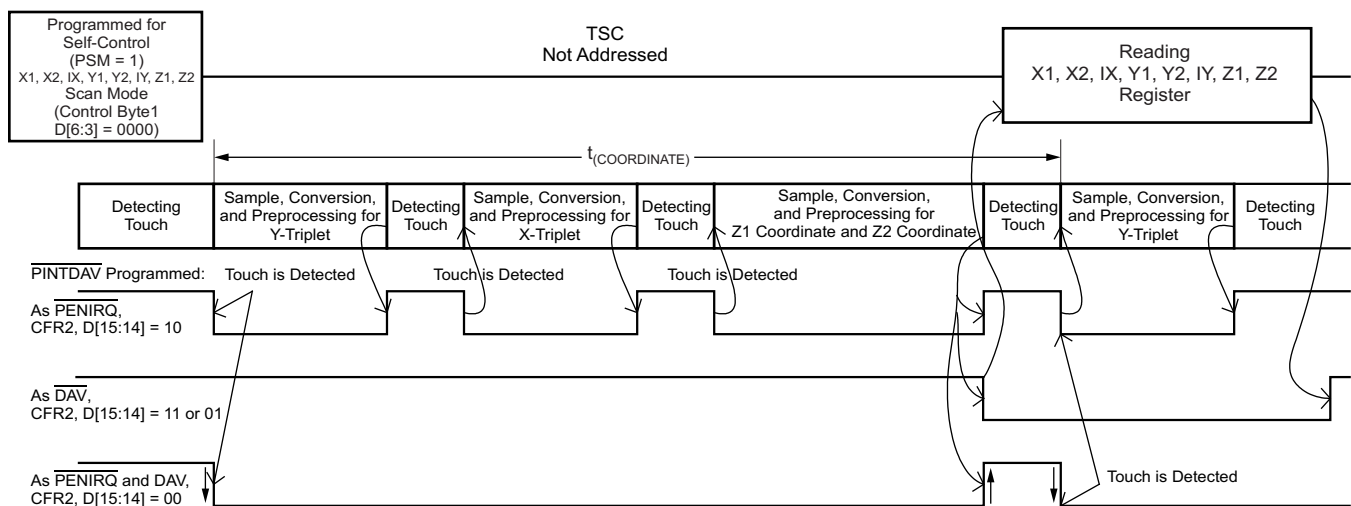
See 表 7 for more information on the converter function-select bits.

The conversion process then proceeds as shown in 图 26. See the IX-IY Scan and X-Triplet, Y-Triplet, Z-Scan sections for additional details.

The main difference between this mode and the previous mode is that the host, not the TSC2013-Q1 device, decides when the touch-screen scan begins.

Use 公式 3 to calculate the time required to convert both IX and IY under host control (not including the time required to send the command over the I²C bus):



图 26. Example of an IX and IY Touch-Screen Scan Using TSMODE 2

7.4.3 Conversion Controlled by Host (TSMODE 3)

In TSMODE 3, the TSC2013-Q1 device detects a touch of the touch panel and causes the internal pen-touch signal to be active, which lowers the PINTDAV output if programmed as PENIRQ. The host recognizes the interrupt request. Instead of starting a sequence in the TSC2013-Q1 device, which then reads each coordinate in turn, the host must now control all aspects of the conversion. Generally, on receiving the interrupt request, the host turns on the X drivers.

注

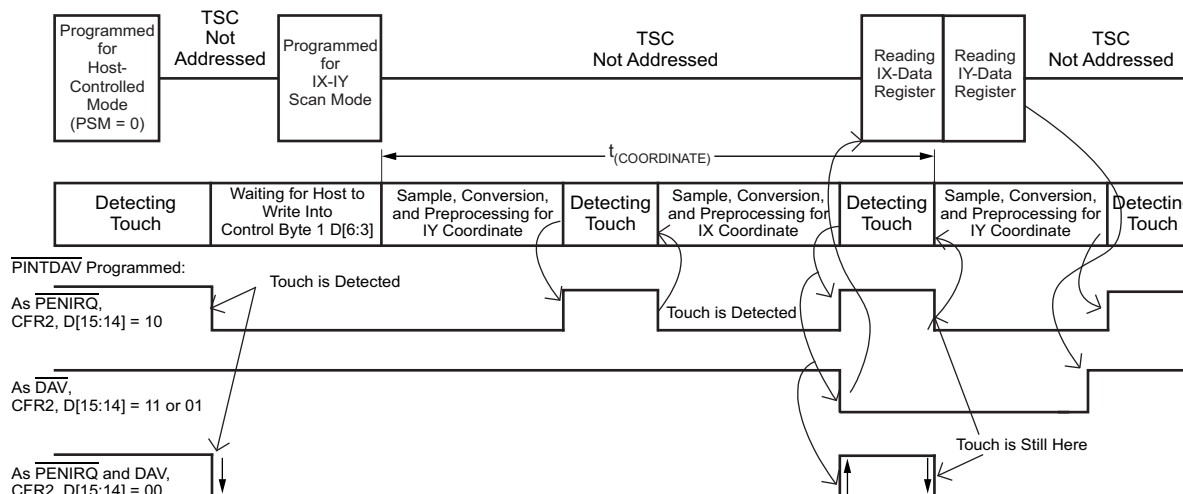
With the drivers turned off, the device detects this condition and turns the driver on before the scan starts. This situation is why the event of *turn on drivers* is shown as optional in 图 27 and 图 29.

After waiting for the settling time, the host then addresses the TSC2013-Q1 device again, this time requesting an X-coordinate conversion.

The process then repeats for the Y and Z coordinates. 图 27 and 图 29 show this process. 图 27 shows two consecutive scans on IX and IY. 图 29 shows a single Z scan.

Use 公式 5 to calculate the time required to convert any single X-triplet or Y-triplet under host control (not including the time required to send the command over the I²C bus):

$$t_{(\text{COORDINATE})} = \frac{t_{(\text{OH1})}}{f_{(\text{OSC})}} + \left(t_{(\text{PRE})} + t_{(\text{SNS})} + \frac{t_{d(\text{OH2})}}{f_{(\text{OSC})}} \right) + 3N \times \left(\left[(B + 2) \times \frac{f_{(\text{OSC})}}{f_{(\text{ADC})}} + t_{c(\text{OH})} \right] \times \left[\frac{1}{f_{(\text{OSC})}} \right] + \left[\frac{t_{(\text{PPRO})}}{f_{(\text{OSC})}} \right] \right)$$

where

- $t_{d(\text{OH2})}$ = total overhead time for $t_{(\text{PRE})}$ and $t_{(\text{SNS})} = 6$ internal clock cycles (5)

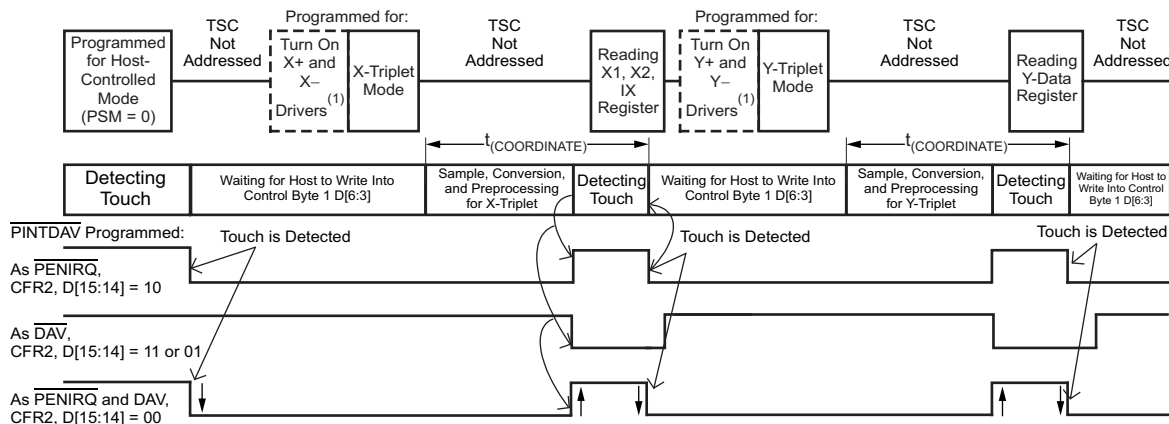

- (1) Optional. If not turned on, it will be turned on by the scan mode, when detected.

图 27. Example of X-Triplet and Y-Triplet Touch-Screen Scan (Without Panel Stabilization Time) Using TSMODE 3

Use 公式 6 to calculate the time required to convert any single X-triplet or Y-triplet under host control (not including the time required to send the command over the I²C bus):

$$t_{(\text{COORDINATE})} = \frac{t_{(\text{OH1})}}{f_{(\text{OSC})}} + \left(t_{(\text{PVS})} + t_{(\text{PRE})} + t_{(\text{SNS})} + \frac{t_{d(\text{OH2})}}{f_{(\text{OSC})}} \right) + 3N \times \left(\left[(B + 2) \times \frac{f_{(\text{OSC})}}{f_{(\text{ADC})}} + t_{c(\text{OH})} \right] \times \left[\frac{1}{f_{(\text{OSC})}} \right] + \left[\frac{t_{(\text{PPRO})}}{f_{(\text{OSC})}} \right] \right) \quad (6)$$



图 28. Example of a Single X-Triplet Touch-Screen Scan (With Panel Stabilization Time) Using TSMODE 3

Use 公式 7 to calculate the time required to convert any Z1 and Z2 coordinate under host control (not including the time required to send the command over the I²C bus):

$$t_{(\text{COORDINATE})} = \frac{t_{(\text{OH2})}}{f_{(\text{OSC})}} + \left(t_{(\text{PRE})} + t_{(\text{SNS})} + \frac{t_{d(\text{OH2})}}{f_{(\text{OSC})}} \right) + N \times \left(\left[(B + 2) \times \frac{f_{(\text{OSC})}}{f_{(\text{ADC})}} + t_{c(\text{OH})} \right] \times \left[\frac{1}{f_{(\text{OSC})}} \right] + \left[\frac{t_{(\text{PPRO})}}{f_{(\text{OSC})}} \right] \right) \quad (7)$$

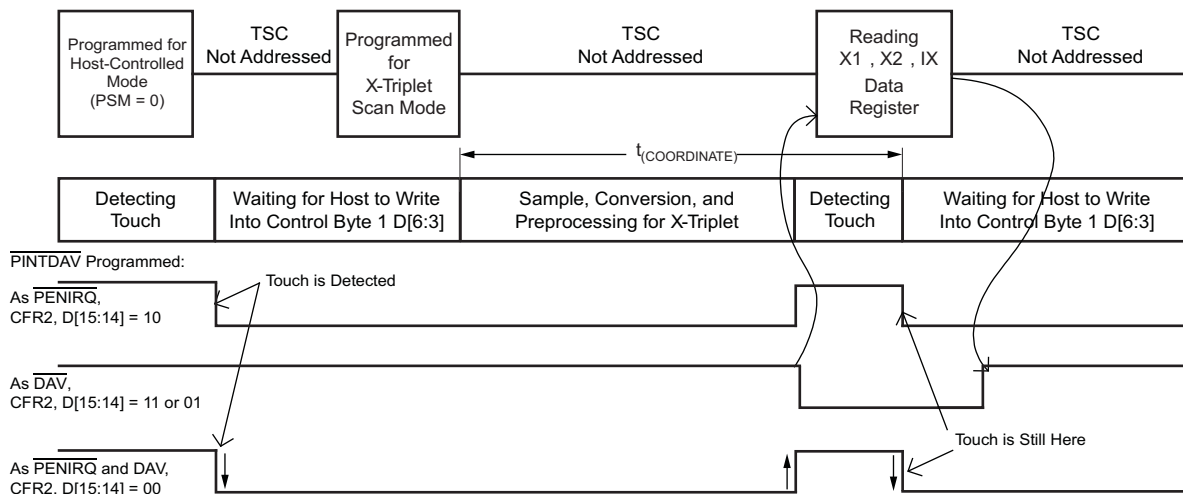
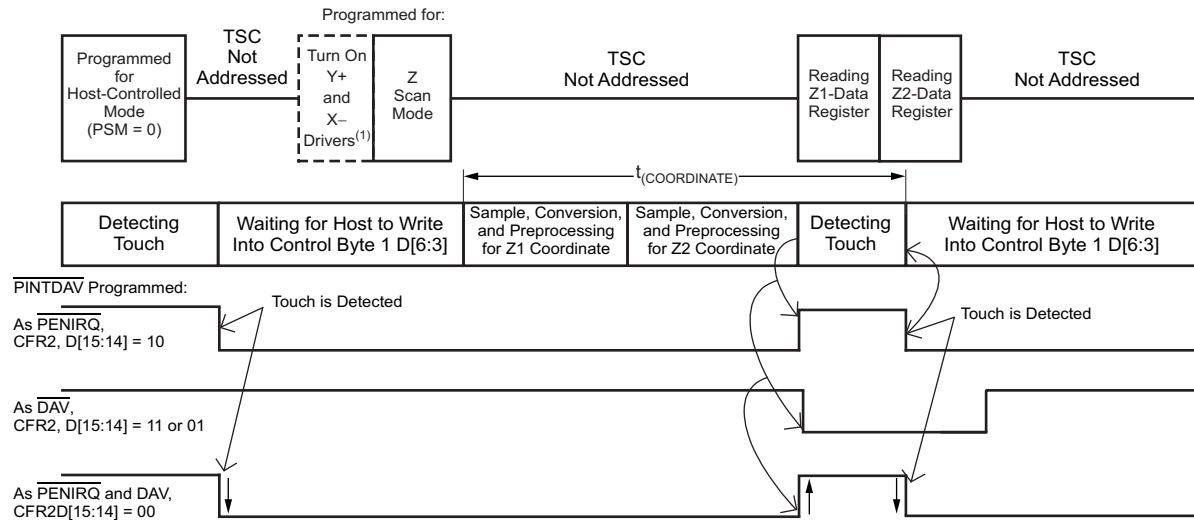

(1) Optional. If not turned on, it will be turned on by the scan mode, when detected.

图 29. Example of Z1 and Z2 Coordinate Touch-Screen Scan (Without Panel Stabilization Time) Using TSMODE 3

If the drivers do not turn on prior to programming the touch-screen scan mode, include the panel stabilization time. In this case, use 公式 8 to calculate the time required to convert any single X or Y under host control (not including the time required to send the command over the I²C bus):

$$t_{(\text{COORDINATE})} = \frac{t_{(\text{OH2})}}{f_{(\text{OSC})}} + \left(t_{(\text{PVS})} + t_{(\text{PRE})} + t_{(\text{SNS})} + \frac{t_{d(\text{OH2})}}{f_{(\text{OSC})}} \right) + N \times \left(\left[(B + 2) \times \frac{f_{(\text{OSC})}}{f_{(\text{ADC})}} + t_{c(\text{OH})} \right] \times \left[\frac{1}{f_{(\text{OSC})}} \right] + \left[\frac{t_{(\text{PPRO})}}{f_{(\text{OSC})}} \right] \right) \quad (8)$$



图 30. Example of a Z1 and Z2 Coordinate Touch-Screen Scan (With Panel Stabilization Time) Using TSMODE 3

7.5 Programming

7.5.1 I²C Interface

The TSC2013-Q1 device supports the I²C serial bus and data transmission protocol in all three defined modes: standard, fast, and high-speed. A device that sends data onto the bus has the definition of a transmitter, and a device receiving data that of a receiver. The device that controls the message is a *master*. Devices controlled by the master are *slaves*. A master device that generates the serial clock (SCL), controls bus access, and generates the START and STOP conditions must control the bus. The TSC2013-Q1 device operates as a slave on the I²C bus. Connections to the bus are through the open-drain I/O lines, SDA and SCL.

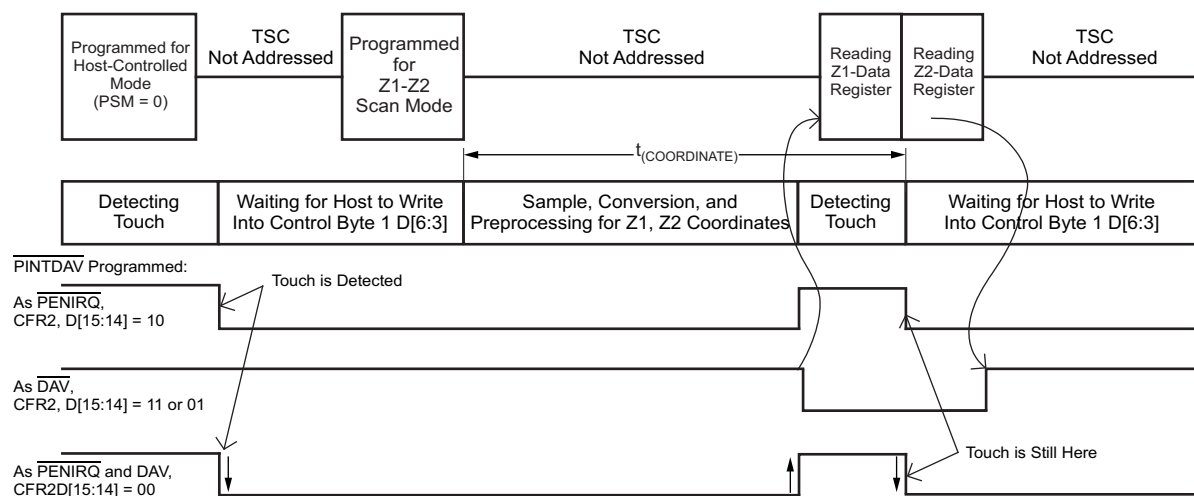
The following bus protocol has been defined (see [图 31](#)):

- A device can initiate data transfer only when the bus is not busy.
- During data transfer, the data line must remain stable whenever the clock line is high. Changes in the data line while the clock line is high are interpreted as control signals.

Accordingly, definitions for the following bus conditions follow:

Bus Not Busy Both data and clock lines remain high.

Start Data Transfer A change in the state of the data line, from high to low, while the clock is high, defines a start condition.

Stop Data Transfer A change in the state of the data line, from low to high, while the clock line is high, defines the stop condition.

Data Valid The state of the data line represents valid data, when, after a start condition, the data line is stable for the duration of the high period of the clock signal. One clock pulse occurs per bit of data.

Each data transfer begins with a start condition and terminates with a stop condition. The number of data bytes transferred between start and stop conditions, which the master device determines, is not limited. The information transfers byte-wise, and the receiver acknowledges each byte with a ninth bit.

The I²C bus specifications define a standard mode (100-kHz clock rate), a fast mode (400-kHz clock rate), and a high-speed mode (3.4-MHz clock rate). The TSC2013-Q1 device works in all three modes.

Acknowledge Each receiving device, when addressed, must generate an acknowledge after the reception of each byte. The master device must generate an extra clock pulse for association with this acknowledge bit.

A device that acknowledges must pull down the SDA line during the acknowledge clock pulse in such a way that the SDA line is stable low during the high period of the acknowledge clock pulse. Of course, the timing must take into account setup and hold times. A master must signal an end-of-data to the slave by not generating an acknowledge bit on the last byte that clocks out of the slave. In this case, the slave must leave the data line high to enable the master to generate the stop condition.

[图 31](#) shows the data-transfer process on the I²C bus. Depending on the state of the $\overline{R/\overline{W}}$ bit, two types of data transfer are possible:

1. Data transfer from a master transmitter to a slave receiver.

The first byte transmitted by the master is the slave address. A number of data bytes occurs next. The slave returns an acknowledge bit after the slave address and each received byte.

2. Data transfer from a slave transmitter to a master receiver.

The master transmits the first byte, the slave address. The slave then returns an acknowledge bit. Next, the slave transmits a number of data bytes to the master. The master returns an acknowledge bit after all received bytes other than the last byte. At the end of the last received byte, the master returns a not-acknowledge.

The master device generates all of the serial clock pulses and the start and stop conditions. A transfer ends with a stop condition or a repeated start condition. Because a repeated start condition is also the beginning of the next serial transfer, the bus is not released.

Programming (接下页)

The TSC2013-Q1 device can operate in the following two modes:

1. Slave receiver mode

Reception of serial data and clock is through SDA and SCL. After the reception of each byte, the receiver transmits an acknowledge bit. Start and stop conditions designate the beginning and end of a serial transfer. Hardware performs address recognition after reception of the slave address and direction bit.

2. Slave transmitter mode

Reception and handling of the first byte (the slave address) is the same as in the slave receiver mode. However, in this mode the direction bit indicates a reversal of the transfer direction. Serial data transmission on SDA by the TSC2013-Q1 device occurs during input of the serial clock on SCL. Start and stop conditions designate the beginning and end of a serial transfer.

7.5.1.1 I²C Fast or Standard Mode (F-S Mode)

In I²C fast or standard (F-S) mode, serial data transfer must meet the timing shown in the timing requirement tables in the [Specifications](#) section.

In the serial transfer format of F-S mode, the master signals the beginning of a transmission to a slave with a start condition (S), which is a high-to-low transition on the SDA input while SCL is high. When the master has finished communicating with the slave, the master issues a stop condition (P), which is a low-to-high transition on SDA while SCL is high, as shown in [图 31](#). The bus is free for another transmission after the occurrence of a stop. [图 31](#) shows the complete F-S mode transfer on the I²C, two-wire serial interface. Transmission of the address byte, control byte, and data byte is between the start and stop conditions. The SDA state can only change while SCL is low, except for the start and stop conditions. Data transmission is in 8-bit words. Nine clock cycles are necessary to transfer the data into or out of the device (8-bit word plus acknowledge bit).



图 31. Complete Fast or Standard-Mode Transfer

Programming (接下页)

7.5.1.2 I²C High-Speed Mode (Hs Mode)

Serial data transfer format in high-speed (Hs) mode meets the fast or standard (F-S) mode I²C bus specification. Hs mode can only commence after the following conditions (all of which are in F-S mode) exist:

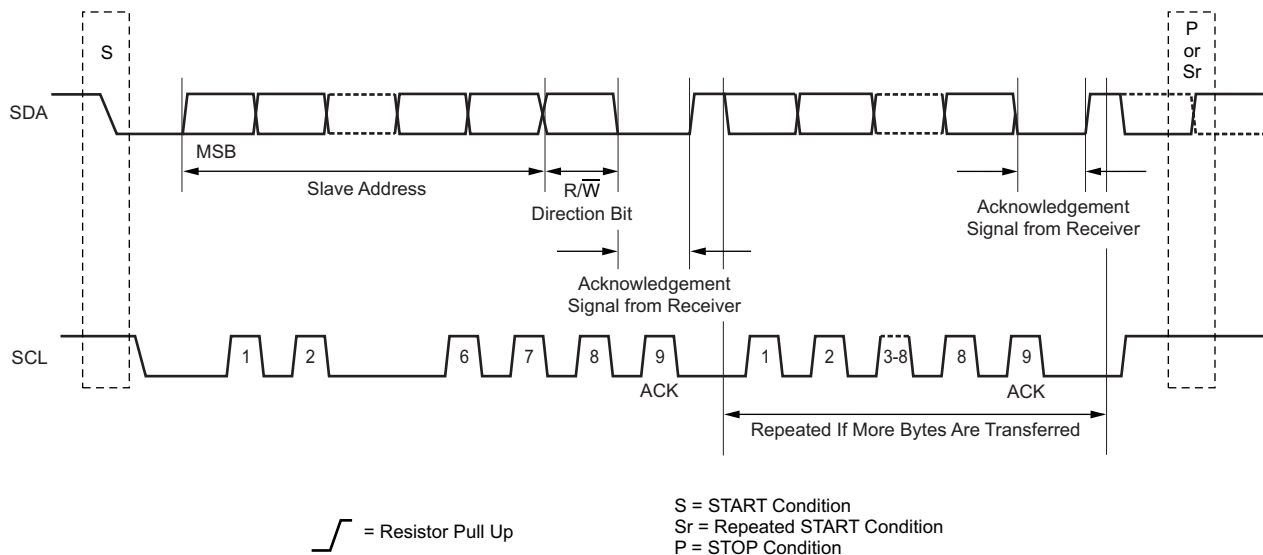
1. Start condition (S)
2. 8-bit master code (0000 1xxx)
3. Not-acknowledge bit (N)

图 32 shows this sequence in more detail. Hs-mode master codes are reserved 8-bit codes used only for triggering Hs mode. Do not use these codes for slave addressing or any other purpose. The master code indicates to other devices that an Hs-mode transfer is about to begin and the connected devices must meet the Hs mode specification. Because no device can acknowledge the master code, a not-acknowledge bit (N) follows the master code.

After the not-acknowledge bit (N) and SCL achieve a high level, the master switches to Hs-mode and enables (at time $t_{(H)}$; shown in 图 32) the current-source pullup circuit for SCL. Because other devices can delay the serial transfer before $t_{(H)}$ by stretching the LOW period of SCL, the master enables the current-source pullup circuit when all devices have released SCL and SCL has reached a high level, thus speeding up the last part of the rise time of the SCL.

The master then sends a repeated start condition (Sr) followed by a 7-bit slave address with an R/W bit address, and receives an acknowledge bit (A) from the selected slave. After a repeated start (Sr) condition and after each acknowledge bit (A) or not-acknowledge bit (N), the master disables the current-source pullup circuit. This disabling enables other devices to delay the serial transfer by stretching the low period of SCL. The master re-enables the current-source pullup circuit again when all devices have released, and SCL reaches a high level, which speeds up the last part of the SCL signal rise time.

Data transfer continues in Hs mode after the next repeated start (Sr), and only switches back to F-S mode after a stop condition (P). To reduce the overhead of the master code, the master can link to a number of Hs mode transfers, separated by repeated start conditions (Sr).



图 32. Complete High-Speed Mode Transfer

Programming (接下页)

7.5.2 Digital Interface

7.5.2.1 Address Byte

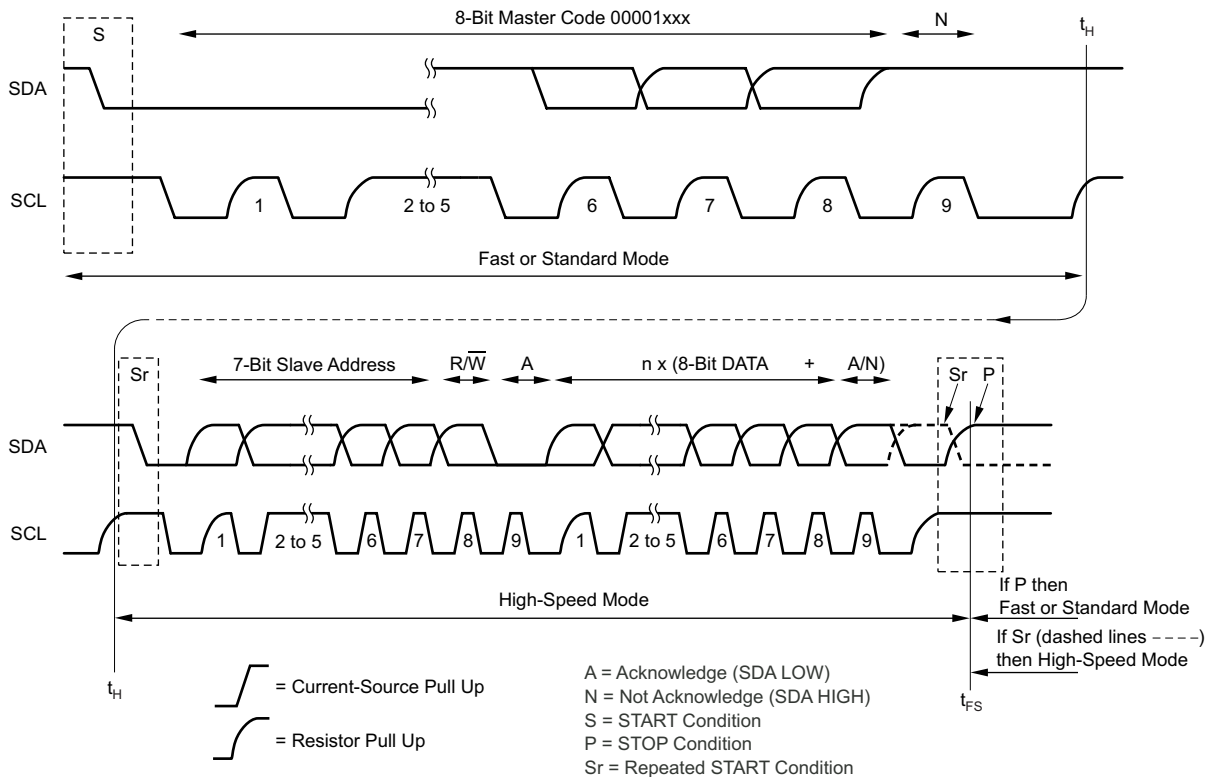
The TSC2013-Q1 device has a 7-bit slave address word. The factory presets the first five bits (MSBs) of the slave address to comply with the I²C standard for ADCs; the setting is always 1 0010. The logic state of the address input pins (AD1 through AD0) determines the two LSBs of the device address to activate communication. Therefore, one bus can accommodate a maximum of four devices with the same preset code at one time.

The device only reads the AD1 through AD0 address inputs during a power-up of the device, and the pin connections should be to a digital supply (I/OVDD) or digital ground (DGND). The TSC2013-Q1 latches the slave address on the falling edge of SCL after reception of the R/W bit by the slave.

The last bit of the address byte (R/\overline{W}) defines the operation to be performed. Setting the bit to 1 selects a read operation. Setting the bit to 0 selects a write operation. Following the start condition, the TSC2013-Q1 device monitors the SDA bus, checking the transmitted device-type identifier. On receiving the 1 0010 code, the appropriate device select bits, and the R/W bit, the slave device outputs an acknowledge signal on the SDA line.

表 5. I²C Slave Address Byte

MSB D7	D6	D5	D4	D3	D2	D1	LSB D0
1	0	0	1	0	AD1	AD0	R/\overline{W}

R/\overline{W} (D0)

1: I²C master read from TSC (I²C read addressing).

0: I²C master write to TSC (I²C write addressing).



图 33. I²C Bus Addressing (Slave-Address Byte Format)

7.5.3 Control Byte

表 6. Control Byte Format: Start a Conversion and Mode Setting, D7 = 1

MSB D7	D6	D5	D4	D3	D2	D1	LSB D0
1 (Control Byte 1)	C3	C2	C1	C0	RM	SWRST	STS

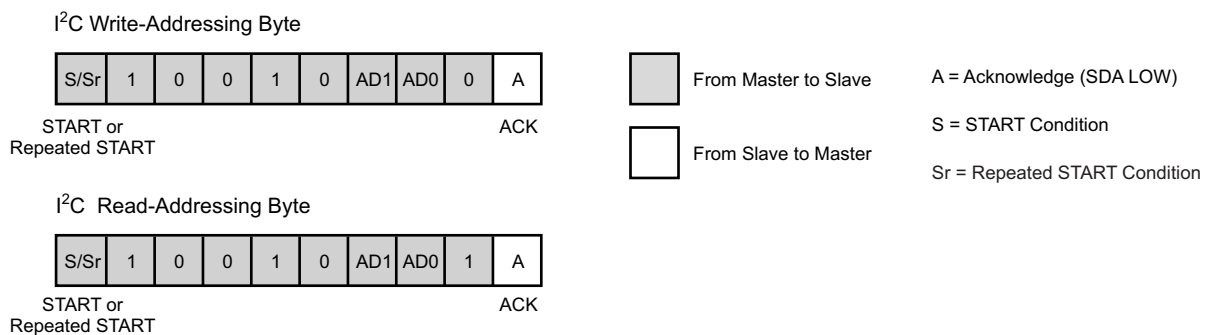
Control Byte ID (D7) 1: Control Byte 1 (start conversion and channel select and conversion-related configuration).

0: Control Byte 0 (read/write data registers and non-conversion-related controls).

C[3:0] (D6:D3)

Converter function select bits

These bits select the input for conversion, and the converter function to be executed. [表 7](#) lists the possible converter functions.

RM (D2)

Resolution select

If RM = 1, the conversion-result resolution is 12-bit; otherwise, the resolution is 10-bit. This bit is the same RM bit shown in CFR0.

0: 10-bit

1: 12-bit

SWRST (D1)

Software reset. This bit is self-clearing.

1: Reset all register values to default

STS (D0)

Stop bit for all converter functions. This bit is self-clearing.

On writing a 1 to this register, this bit aborts the converter function currently running in the TSC2013-Q1. An automatic write of 0 to this register occurs when the abort has completed. Setting this bit to 1 can only stop converter functions; it does not reset any data, status, or configuration registers. This bit is the same STS bit shown in CFR0, but reading can only be through the CFR0 register.

Write 0: Normal operation

Write 1: Stop converter functions and power down

表 7. Converter Function Select

C3	C2	C1	C0	FUNCTION
0	0	0	0	Touch-Screen Scan function: X triplet, Y triplet, Z1, and Z2 coordinates converted and the results returned to X1, X2, IX, Y1, Y2, IY, Z1, and Z2 data registers. Scan continues until either lifting of the pen or sending of a stop bit.
0	0	0	1	Touch-Screen Scan function: IX and IY coordinates converted and the results returned to IX and IY data registers. Scan continues until either lifting of the pen or sending of a stop bit.
0	0	1	0	Touch screen function: X triplet converted and the results returned to X1, X2, IX data register.
0	0	1	1	Touch screen function: Y triplet converted and the results returned to Y1, Y2, IY data register.
0	1	0	0	Touch screen function: Z1 and Z2 coordinates converted and the results returned to Z1 and Z2 data registers.
0	1	0	1	Auxiliary input converted and the results returned to the AUX data register.
0	1	1	0	Touch screen function: IX converted and result returned to IX data register.
0	1	1	1	Touch screen function: IY converted and result returned to IY data register.
1	0	0	0	Auxiliary input conversion occurs continuously and the results returned to the AUX data register.
1	0	0	1	RESERVED
1	0	1	0	RESERVED
1	0	1	1	RESERVED ⁽¹⁾
1	1	0	0	RESERVED
1	1	0	1	X+, X– drivers activated
1	1	1	0	Y+, Y– drivers activated
1	1	1	1	Y+, X– drivers activated

(1) Any condition caused by this command can be cleared by setting the STS bit to 1.

表 8. Control Byte Format: Start a Conversion and Mode Setting D7 = 0

MSB D7	D6	D5	D4	D3	D2	D1	LSB D0
0 (Control Byte 0)	A3	A2	A1	A0	Reserved (Write 0)	PND0	R/ \bar{W}

Control byte ID (D7)	1: Control byte 1—start conversion, channel select, and conversion-related configuration 0: Control byte 0—read/write data registers and non-conversion-related controls
A[3:0] (D6:D3)	Register address bits as detailed in 表 9
RESERVED (D2)	Set a 0 in this bit for normal operation
PND0 (D1)	Power-not-down control 1: ADC biasing circuitry is always on between conversions but shuts down after the converter function stops 0: ADC biasing circuitry shuts down either between conversions or after the converter function stops. Example power savings for the following condition is approximately 5%: AUX conversion, continuous mode, median filter = 15, averaging filter = 7, $f_{(ADC)} = 2$ MHz.
R/ \bar{W} (D0)	TSC internal-register data-flow control 1: Set the starting address of the TSC internal registers for a register read (see 图 34) 0: Write to TSC internal registers

7.5.3.1 Touch-Screen Scan Function for XYZ or XY

These scan functions (C3–C0 = 0000 or 0001) can collaborate with the PSM bit that defines the control mode of converter functions. With the PSM bit set to 1, TI recommends issuing these scan-function select commands before detection of a pen touch in order to allow the TSC2013-Q1 device to initiate and control the scan processes immediately after detection of the screen touched. Without issuing these functions before detection of a pen touch, the TSC2013-Q1 waits for the host to write these functions before starting a scan process. If PSM stays as 1 after a TSC-initiated scan function is complete, the host is not required to write these function-select bits again for each of the following pen touches after the detected touch. In the host-controlled converter function mode (PSM = 0), the host must send these functions select bits repeatedly for each scan function after a detected pen touch.

注

The update of the data registers may occur while a host reading is in progress. Using the sequential read cycle (see [图 35](#)) prevents the TSC from updating registers while a host reading is in progress. To ensure a correct reading of the XYZ or XY coordinates, use the sequential read cycle to read the coordinates after the scan.

表 9. Internal Register Map

REGISTER ADDRESS				REGISTER CONTENT	READ/WRITE
A3	A2	A1	A0		
0	0	0	0	X1 measurement result	R
0	0	0	1	X2 measurement result	R
0	0	1	0	Y1 measurement result	R
0	0	1	1	Y2 measurement result	R
0	1	0	0	I _x measurement result	R
0	1	0	1	I _y measurement result	R
0	1	1	0	Z1 measurement result	R
0	1	1	1	Z2 measurement result	R
1	0	0	0	Status	R
1	0	0	1	AUX measurement result	R
1	0	1	0	RESERVED	
1	0	1	1	RESERVED	
1	1	0	0	CFR0	R/W
1	1	0	1	CFR1	R/W
1	1	1	0	CFR2	R/W
1	1	1	1	Converter function select status	R

$\overline{R/W}$ is the register read and write control. A 1 indicates that the value of the internal register address bits A3–A0 is stored internally as the starting address for a register read (see 图 34). The content of the addressed register is sent to SDA by using I²C read addressing (see 图 35 and 图 36). A0 indicates that the data following control byte 0 on SDA are written into the internal register addressed by bits A3–A0 (see 图 34).

7.5.4 Start a Write Cycle

A write cycle begins when the master issues the slave address to the TSC2013-Q1 device. The slave address consists of seven address bits and a write bit ($R/\overline{W} = 0$; see 表 6). On receipt of the eighth bit, if the address matches the AD1 through AD0 address input pin setting, the TSC2013-Q1 device issues an acknowledge bit by pulling SDA low for one additional clock cycle ($ACK = 0$); see 图 33.

When the master receives the acknowledge bit from the TSC2013-Q1 device, the master writes the input control byte to the slave (see 表 6). After the control byte is received by the slave, the slave issues another acknowledge bit by pulling SDA low for one clock cycle ($ACK = 0$). The master then ends the write cycle by issuing a STOP or repeated START condition; see 图 34.

Write Cycle

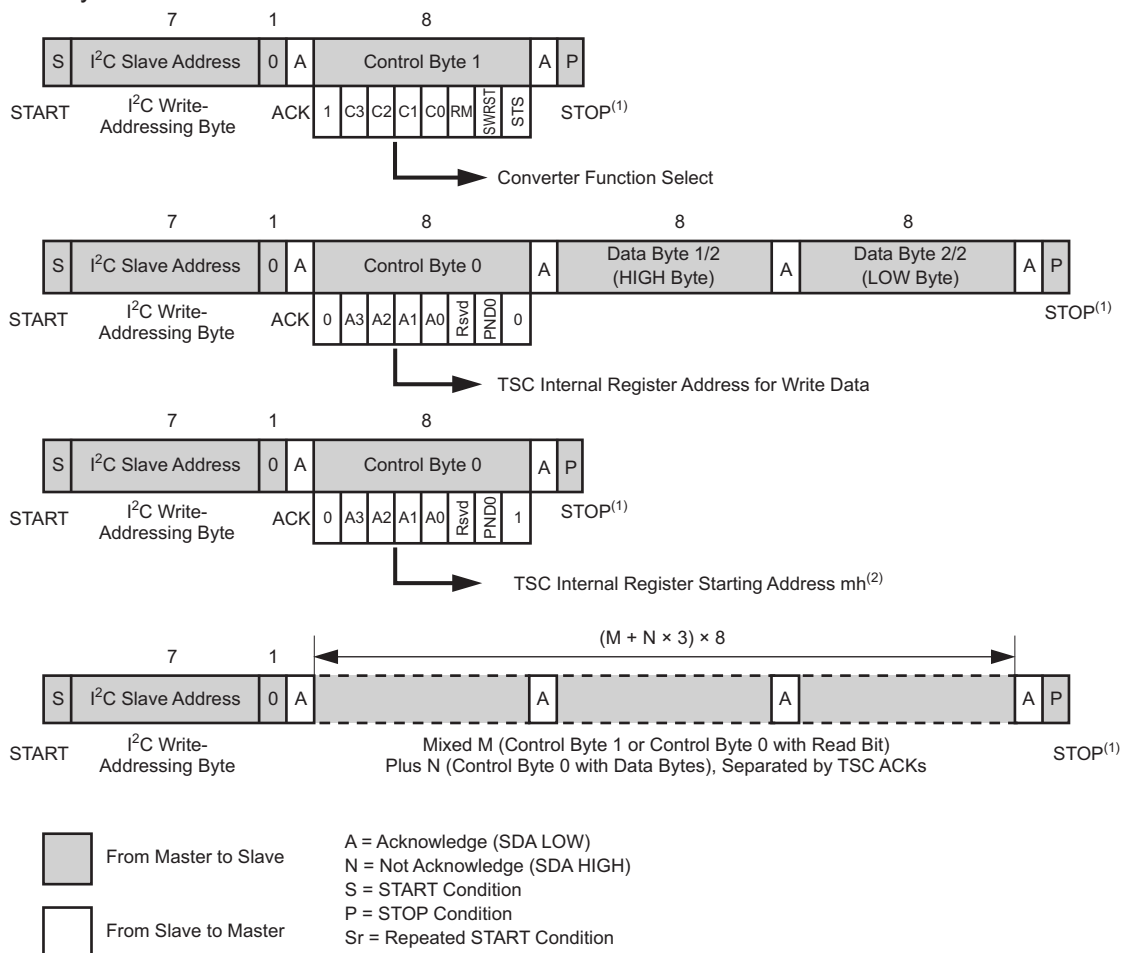

(1) In order to start the next sequence, a stop condition must be followed by a start condition. If no stop is used, then a repeated start (Sr) must be used. Also note that if a stop condition is issued in high-speed mode, the mode reverts to the previous mode which is either fast or standard mode.

(2) mh is a hexadecimal number.

图 34. Write Cycle

7.5.5 Register Access

Data access begins with the master issuing a START (or repeated START) condition followed by the 7-bit address and a read bit ($R/\bar{W} = 1$; see 表 6). On receipt of the eighth bit has been received and an address match, the slave issues an acknowledge by pulling SDA low for one clock cycle ($ACK = 0$). The first byte of serial data then follows. After the slave has sent the first byte, it then releases the SDA line for the master to issue an acknowledge ($ACK = 0$). The slave issues the second byte of serial data on receiving the acknowledgment from the master ($D7-D0$), followed by a not-acknowledge bit ($ACK = 1$) from the master to indicate receipt of the last data byte has been received. The master then issues a STOP condition (P) or repeated START (Sr), which ends the read cycle, as shown in 图 35 and 图 36. If the master issues a not-acknowledge ($ACK = 1$) after receipt of the first data byte, the master must then issue a stop condition (P) to reset the registers. If the master is not ready to receive the second data byte, it should issue the acknowledge ($ACK = 0$), or the master should stretch the clock. On restart of the clock, the master can receive the second byte of data.

Read Cycle: Sequential, from Register Address $mh^{(2)}$ to $(m + n)h^{(3)}$

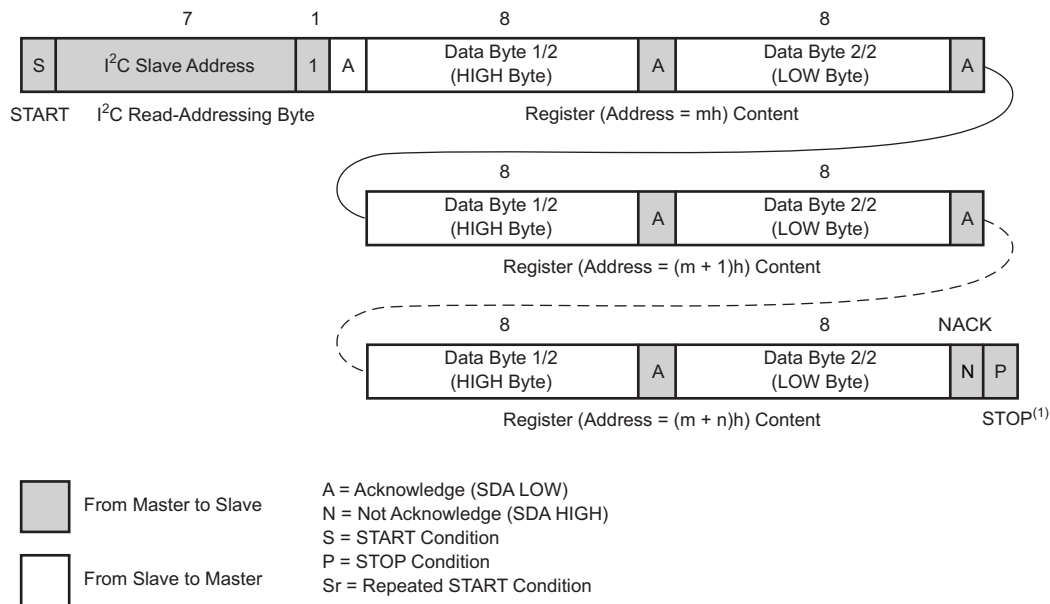

- (1) In order to start the next sequence, a Stop condition must be followed by a start condition. If no stop is used, then a repeated start must be used. Also note that if a stop condition is issued in high-speed mode, the mode reverts to the previous mode which is either fast or standard mode.
- (2) mh is a hexadecimal number.
- (3) If $(m+n)h$ is greater than Fh , then $(m + n)h$ is modulo 16.

图 35. Sequential Read Cycle

Read Cycle: Repeated, Register Address mh⁽²⁾

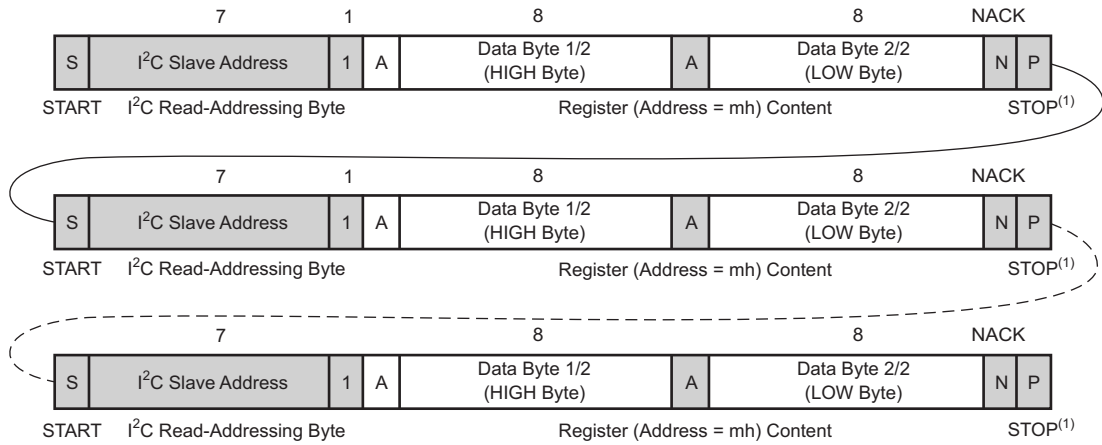

Or...

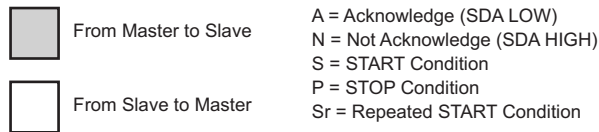
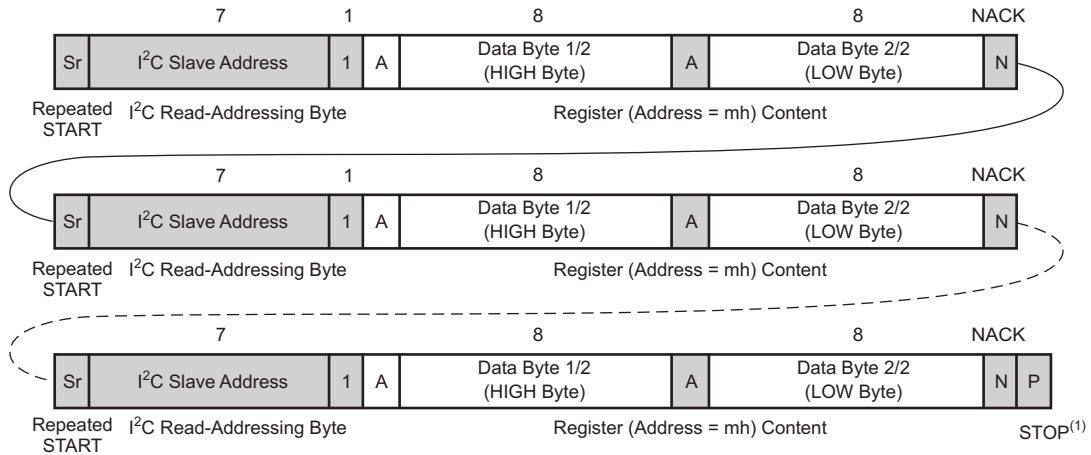

- (1) In order to start the next sequence, a Stop condition must be followed by a start condition. If no stop is used, then a repeated start must be used. Also note that if a stop condition is issued in high-speed mode, the mode reverts to the previous mode which is either fast or standard mode.
- (2) mh is a hexadecimal number.

图 36. Repeated Read Cycle

7.5.6 Communication Protocol

All control of the TSC2013-Q1 is through registers. Reading and writing to these registers are accomplished by the use of Control Byte 0, which includes a 4-bit address plus one read-write TSC register-control bit. The data registers defined in 表 9 are all 16-bit, right-adjusted.

注

Except for some configuration registers and the status register that are full 16-bit registers, the rest of the value registers are 12-bit (or 10-bit) data preceded by four (or six) zeros.

See the [Configuration and Status Registers](#) section for the register field descriptions.

7.5.7 Register Reset

The TSC2013-Q1 device can be reset in one of three ways. First, at power-on, a power-good signal generates a prolonged reset pulse internally to all registers.

Second, an external pin, $\overline{\text{RESET}}$, is available to perform a system reset or allow other peripherals (such as a display) to reset the device if the pulse meets the timing requirement (at least 10 μs in duration). Any $\overline{\text{RESET}}$ pulse less than 5 μs is rejected. To accommodate the timing drift between devices because of process variation, a $\overline{\text{RESET}}$ pulse duration between 5 μs and 10 μs falls into the gray area that is unrecognized, giving an undetermined result; avoid this situation. See 图 37 for details. A good reset pulse must be low for at least 10 μs . An internal spike filter is available to reject spikes up to 20 ns wide.

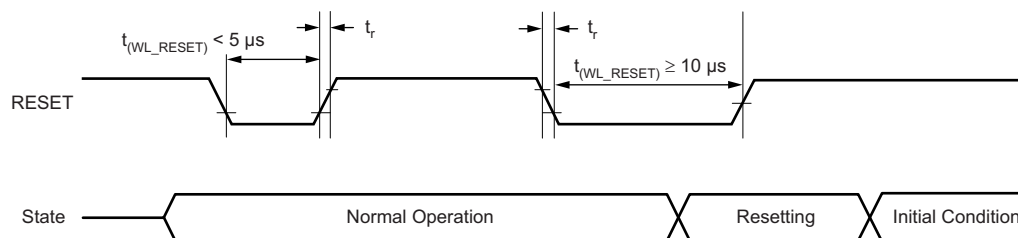

NOTE: See the timing requirement tables in the [Specifications](#) section for more information.

图 37. External Reset Timing

Third, a software reset is activated by writing a 1 to CB1.1 (bit 1 of control byte 1). Note that this reset is not self-clearing, so the user must write a 0 to remove the software reset.

A reset clears all registers and loads default values. A power-on reset and external (hardware) reset take precedence over a software reset. If the user does not clear a software reset, either a power-on reset or an external (hardware) reset clears it.

7.6 Register Maps

The TSC2013-Q1 device has several 16-bit registers that allow control of the device, as well as providing a location to store results from the TSC2013-Q1 device until read out by the host microprocessor. 表 10 shows the memory map.

表 10. Register Content and Reset Values⁽¹⁾

A3-A0 (HEX)	REGISTER NAME	D15	D14	D13	D12	D11	D10	D9	D8	D7	D6	D5	D4	D3	D2	D1	D0	RESET VALUE (HEX)
0	X1	0	0	0	0	R11	R10	R9	R8	R7	R6	R5	R4	R3	R2	R1	R0	0000
1	X2	0	0	0	0	R11	R10	R9	R8	R7	R6	R5	R4	R3	R2	R1	R0	0000
2	Y1	0	0	0	0	R11	R10	R9	R8	R7	R6	R5	R4	R3	R2	R1	R0	0000
3	Y2	0	0	0	0	R11	R10	R9	R8	R7	R6	R5	R4	R3	R2	R1	R0	0000
4	IX	T ⁽²⁾	0	0	0	R11	R10	R9	R8	R7	R6	R5	R4	R3	R2	R1	R0	0000
5	IY	T ⁽²⁾	0	0	0	R11	R10	R9	R8	R7	R6	R5	R4	R3	R2	R1	R0	0000
6	Z1	0	0	0	0	R11	R10	R9	R8	R7	R6	R5	R4	R3	R2	R1	R0	0000
7	Z2	0	0	0	0	R11	R10	R9	R8	R7	R6	R5	R4	R3	R2	R1	R0	0000
8	Status	DAVX	DAVY	DAVZ 1	DAVZ 2	DAVAUX	0	0	0	RESET	0	0	0	0	PDST	0	0	0004
9	AUX	0	0	0	0	R11	R10	R9	R8	R7	R6	R5	R4	R3	R2	R1	R0	0000
A	RSVD	0	0	0	0	0	0	0	0	0	0	0	0	0	0	0	0	0000
B	RSVD	0	0	0	0	0	0	0	0	0	0	0	0	0	0	0	0	0000
C	CFR0	PSM	STS	RM	CL1	CL0	PV2	PV1	PV0	PR2	PR1	PR0	SN2	SN1	SN0	DTW	LSM	4000
D	CFR1	0	0	0	0	0	0	0	0	0	0	0	0	0	BTD2	BTD1	BTD0	0000
E	CFR2	PINTS1	PINTS0	M1	M0	W1	W0	0	0	0	0	0	MAVE X TRIPLET	MAVE Y TRIPLET	MAVE Z	MAVE AUX	0	0000
F	CFN	CFN15	CFN14	CFN13	0	0	0	0	CFN8	CFN7	R6	R5	R4	R3	R2	R1	R0	0000

(1) For all combination bits, do not use the pattern marked as *RSVD* (reserved). The default pattern is read back after reset.

(2) Use of the D15 bit only occurs during a single IX or single IY conversion command.

T = 0: No touch detected during conversion

T = 1: Touch detected during conversion

7.6.1 Configuration and Status Registers

7.6.1.1 Configuration Register 0

7.6.1.1.1 Configuration Register 0 (address = 0) [reset = 4000h for read; 0000h for write]

图 38. Configuration Register 0

D15	D14	D13	D12	D11	D10	D9	D8
PSM	STS	RM	CL[1:0]		PV[2:0]		
R/W-Reset	R/W-	R/W-	R/W-		R/W-		
D7	D6	D5	D4	D3	D2	D1	D0
PR[2:0]		SN[2:0]			DTW	LSM	
R/W-		R/W-			R/W-	R/W-	

表 11. Configuration Register 0 Field Descriptions

Bit	Field	Type	Reset	Description
D15	PSM	R/W	0	<p>Pen status or control mode. This bit is the MSB.</p> <p>Reading this bit allows the host to determine if a touch of the screen has occurred. Writing to this bit selects the mode used to control the flow of converter functions that are either initiated and/or controlled by host or under control of the TSC2013-Q1 responding to a pen touch. When reading, the PSM bit indicates if the pen is down or not. When writing to this register, this bit determines if the TSC2013-Q1 or the host controls the converter functions. The default state is the host-controlled converter function mode (0). The other state (1) is the TSC-initiated scan function mode that must only collaborate with C3–C0 = 0000 or 0001 in order to allow the TSC2013-Q1 to initiate and control the scan function for XYZ or XY when a on detection of a pen touch.</p> <p>0 (R): No screen touch detected 1 (R): Screen touch detected 0 (W): Converter functions initiated and/or controlled by host 1 (W): Converter functions initiated and controlled by the TSC2013-Q1</p>
D14	STS	R/W	1 for R 0 for W	<p>ADC status</p> <p>When reading, this bit indicates if the converter is busy or not busy. Continuous scans or conversions can be stopped by writing a 1 to this bit, immediately aborting the running converter function (even if the pen is still down) and causing the ADC to power down. The default state for write is 0 (normal operation), and the default state for read is 1 (converter is not busy). Note that the same bit can be written through Control Byte 1 (bit 0). This bit is self-clearing.</p> <p>0 (R): Converter is busy 1 (R): Converter is not busy 0 (W): Normal operation 1 (W): Stop converter function and power down</p>
D13	RM	R/W	0	<p>Resolution control</p> <p>This bit specifies the ADC resolution. See for a description of these bits. This bit is the same whether reading or writing, and defaults to 0. Note that one can write the same bit through Control Byte 1.</p> <p>0: 10-bit resolution. Default after power up and reset 1: 12-bit resolution</p>

表 11. Configuration Register 0 Field Descriptions (接下页)

Bit	Field	Type	Reset	Description
D12-D11	CL[1:0]	R/W	0	<p>Conversion-clock control</p> <p>These two bits specify CL bits that specify the clock rate that the ADC uses to perform conversion.</p> <p>CL1 = 0, CL0 = 0: $f_{(ADC)} = f_{(OSC)} / 1$, referred to as the 4-MHz ADC clock rate, 10-bit resolution only</p> <p>CL1 = 0, CL0 = 1: $f_{(ADC)} = f_{(OSC)} / 2$, referred to as the 2-MHz ADC clock rate</p> <p>CL1 = 1, CL0 = 0: $f_{(ADC)} = f_{(OSC)} / 4$, referred to as the 1-MHz ADC clock rate</p> <p>CL1 = 1, CL0 = 1: $f_{(ADC)} = f_{(OSC)} / 4$, referred to as the 1-MHz ADC clock rate</p>
D10-D8	PV[2:0]	R/W	0	<p>Panel-voltage stabilization-time control</p> <p>These bits specify a delay time from the moment of touch-screen drivers enabling to the time of voltage sampling and the start of a conversion. These bits allow the user to adjust the appropriate settling time for the touch panel and external capacitances. See for settings of these bits. The default state is 000, indicating a 0-μs stabilization time ($t_{(PVS)}$). These bits are the same whether reading or writing.</p> <p>PV2 = 0, PV1 = 0, PV0 = 0: 0 μs</p> <p>PV2 = 0, PV1 = 0, PV0 = 1: 100 μs</p> <p>PV2 = 0, PV1 = 1, PV0 = 0: 500 μs</p> <p>PV2 = 0, PV1 = 1, PV0 = 1: 1 ms</p> <p>PV2 = 1, PV1 = 0, PV0 = 0: 5 ms</p> <p>PV2 = 1, PV1 = 0, PV0 = 1: 10 ms</p> <p>PV2 = 1, PV1 = 1, PV0 = 0: 50 ms</p> <p>PV2 = 1, PV1 = 1, PV0 = 1: 100 ms</p>
D7-D5	PR[2:0]	R/W	0	<p>Precharge time selection</p> <p>These bits set the amount of time allowed for precharging any pin capacitance on the touch screen prior to sensing whether a pen touch is in progress. The following lists the precharge time ($t_{(PRE)}$)</p> <p>PR2 = 0, PR1 = 0, PR0 = 0: 20 μs</p> <p>PR2 = 0, PR1 = 0, PR0 = 1: 84 μs</p> <p>PR2 = 0, PR1 = 1, PR0 = 0: 276 μs</p> <p>PR2 = 0, PR1 = 1, PR0 = 1: 340 μs</p> <p>PR2 = 1, PR1 = 0, PR0 = 0: 1.044 ms</p> <p>PR2 = 1, PR1 = 0, PR0 = 1: 1.108 ms</p> <p>PR2 = 1, PR1 = 1, PR0 = 0: 1.3 ms</p> <p>PR2 = 1, PR1 = 1, PR0 = 1: 1.364 ms</p>
D4-D2	SN[2:0]	R/W	0	<p>Sense-time selection</p> <p>These bits set the amount of time the TSC2013-Q1 device waits after converting a coordinate to sense whether a screen touched is in progress.</p> <p>SNS2 = 0, SNS1 = 0, SNS0 = 0: 32 μs</p> <p>SNS2 = 0, SNS1 = 0, SNS0 = 1: 96 μs</p> <p>SNS2 = 0, SNS1 = 1, SNS0 = 0: 544 μs</p> <p>SNS2 = 0, SNS1 = 1, SNS0 = 1: 608 μs</p> <p>SNS2 = 1, SNS1 = 0, SNS0 = 0: 2.08 ms</p> <p>SNS2 = 1, SNS1 = 0, SNS0 = 1: 2.144 ms</p> <p>SNS2 = 1, SNS1 = 1, SNS0 = 0: 2.592 ms</p> <p>SNS2 = 1, SNS1 = 1, SNS0 = 1: 2.656 ms</p>

表 11. Configuration Register 0 Field Descriptions (接下页)

Bit	Field	Type	Reset	Description
D1	DTW	R/W	0	<p>Detection of pen touch in wait (patent pending)</p> <p>Writing a 1 to this bit enables pen-touch detection in the background while waiting for the host to issue the converter function in host-initiated and -controlled modes. This background detection allows the TSC2013-Q1 to pull $\overline{\text{PINTDAV}}$ high to indicate no pen touch detected while waiting for the host to issue the converter function. If the host polls a high state at $\overline{\text{PINTDAV}}$ before the transmission of the convert function, the host can abort the issuance of the convert function and stay in the polling $\overline{\text{PINTDAV}}$ mode until the detection of the next pen touch.</p>
D0	LSM	R/W	0	<p>Longer sampling mode. This bit is the LSB.</p> <p>With this bit set to 1, an extra 500 ns of sampling time is added to the normal sampling cycles of each conversion. This additional time is represented as approximately two internal oscillator clock cycles.</p>

7.6.1.2 Configuration Register 1 (address = Dh) [reset = 0000h]

Configuration register 1 (CFR1) defines the connection test-bit modes configuration and batch-delay selection.

图 39. Configuration Register 1

D15	D14	D13	D12	D11	D10	D9	D8
RESERVED							
W-0							
D7	D6	D5	D4	D3	D2	D1	D0
RESERVED					BTD[2:0]		
W-0					R/W-0		

表 12. Configuration Register 1 Field Descriptions

Bit	Field	Type	Reset	Description
D15-D3	RESERVED	W	0	
D2-D0	BTD[2:0]	R/W	0	<p>Batch time-delay mode</p> <p>These are the selection bits that specify the delay before the triggering of a sample or conversion scan cycle. When it is set, Batch time-delay mode uses a set of timers to trigger a sequence of sample-and-conversion events automatically. The mode works for both TSC-initiated scans (XYZ or XY) and host-initiated scans (XYZ or XY).</p> <p>Configure a TSC-initiated scan (XYZ or XY) by setting the PSM bit in CFR0 to 1 and C[3:0] in control byte 1 to 0000 or 0001. In the case of a TSC-initiated scan (XYZ or XY), the sequence begins with the TSC responding to a pen touch. After the first processed sample set completes during the batch delay, the scan enters a wait mode until the end of the batch delay. If detection of a pen touch persists at that moment, the scan continues to process the next sample set, along with a resumption of the batch delay. The selected batch delay during the time of the detected pen touch regulates the throughput of the processed sample sets (shown in as sample sets per second, or SSPS). One can configure a TSC-initiated scan (XYZ or XY) by setting the PSM bit in CFR0 to 1 and C[3:0] in control byte 1 to 0000 or 0001. Note that the throughput of the processed sample set also depends on the settings of stabilization, precharge, and sense times, and the total number of samples to be processed per coordinates. If the accrual time of these factors exceeds the batch delay time, the accrual time dominates. Batch delay time starts when the pen touch initiates the scan function that converts coordinates.</p> <p>One can configure a host-initiated scan (XYZ or XY) by setting the PSM bit in CFR0 to 0 and C[3:0] in control byte 1 to 0000 or 0001. For the host-initiated scan (XYZ or XY), the host must set TSC internal register C[3:0] in control byte 1 to 0000 or 0001 initially after a pen-touch detection; see . After engagement of the scan (XYZ or XY), the selected batch-delay timer regulates the throughput of the processed sample sets, as long as the initial detected touch is uninterrupted.</p>

表 12. Configuration Register 1 Field Descriptions (接下页)

Bit	Field	Type	Reset	Description
				<p>Throughput for TSC-initiated or host-initiated scan, XYZ OR XY:</p> <p>BTD2 = 0, BTD1 = 0, BTD0 = 0, t_d = 0: Normal operation throughput depends on settings</p> <p>BTD2 = 0, BTD1 = 0, BTD0 = 1, t_d = 1: 1000 SSPS</p> <p>BTD2 = 0, BTD1 = 1, BTD0 = 0, t_d = 2: 500 SSPS</p> <p>BTD2 = 0, BTD1 = 1, BTD0 = 1, t_d = 4: 250 SSPS</p> <p>BTD2 = 1, BTD1 = 0, BTD0 = 0, t_d = 10: 100 SSPS</p> <p>BTD2 = 1, BTD1 = 0, BTD0 = 1, t_d = 20: 50 SSPS</p> <p>BTD2 = 1, BTD1 = 1, BTD0 = 0, t_d = 40: 25 SSPS</p> <p>BTD2 = 1, BTD1 = 1, BTD0 = 1, t_d = 100: 10 SSPS</p> <p>For example, if stabilization time, precharge time, and sense time are selected as 100 μs, 84 μs, and 96 μs, respectively, and the batch delay time is 2 ms, then the scan function enters wait mode after the first processed sample set until the 2 ms of batch-delay time expires. When the scan function starts to process the second sample set (if a touch is still present on the screen), the batch delay restarts at 2 ms (in this example). This procedure remains regulated by 2 ms until the pen touch is undetected or a stop bit or any reset form stops the scan function.</p>

7.6.1.3 Configuration Register 2 (address = Eh) [reset = 0000h]

Configuration register 2 (CFR2) defines the preprocessor configuration.

图 40. Configuration Register 2

D15		D14		D13		D12		D11		D10		D9		D8			
PINTS1		PINTS0		M[1:0]				W[1:0]				RESERVED					
R/W-0		R/W-0		R/W-00				R/W-00				W-0					
D7				D6		D5		D4		D3		D2		D1		D0	
RESERVED						MAVE X TRIPLET		MAVE Y TRIPLET		MAVE Z		MAVE AUX		RESERVED			
W-0						R/W-0000		R/W-0000		R/W-0000		R/W-0000		W-0			

表 13. Configuration Register 2 Field Descriptions

Bit	Field	Type	Reset	Description
D15	PINTS1	R/W	0	This bit controls the output format of the $\overline{\text{PINTDAV}}$ pin. With this bit set to 0, the output format is the AND-form of internal signals of $\overline{\text{PENIRQ}}$ and DAV). With this bit set to 1, $\overline{\text{PINTDAV}}$ outputs $\overline{\text{PENIRQ}}$ only. $\overline{\text{PINTDAV}}$ PIN OUTPUT = 0: AND combination of $\overline{\text{PENIRQ}}$ (active-low) and DAV (active-high). 0: Data available, $\overline{\text{DAV}}$ (active-low). 1: Interrupt, $\overline{\text{PENIRQ}}$ (active-low) generated by pen-touch. 1: Data available, $\overline{\text{DAV}}$ (active-low).
D14	PINTS0	R/W	0	This bit selects the output on the $\overline{\text{PINTDAV}}$ pin. With this bit set to 0, the output format of $\overline{\text{PINTDAV}}$ depends on the selection made on the PINTS1 bit. With this bit set to 1, $\overline{\text{PINTDAV}}$ outputs the internal signal of DAV. $\overline{\text{PINTDAV}}$ PIN OUTPUT = 0: AND combination of $\overline{\text{PENIRQ}}$ (active-low) and DAV (active-high). 1: Data available, $\overline{\text{DAV}}$ (active-low). 0: Interrupt, $\overline{\text{PENIRQ}}$ (active-low) generated by pen-touch. 1: Data available, $\overline{\text{DAV}}$ (active-low).
D13-D12	M[1:0]	R/W	00	Preprocessing MAV filter control Note that when the MAV filter is processing data, the STS bit and the corresponding DAV bits in the status register indicate that the converter is busy until all conversions necessary for the preprocessing are complete. The default state for these bits is 0000, which bypasses the preprocessor. These bits are the same whether reading or writing.
D11-D10	W[1:0]	R/W	00	Preprocessing MAV filter control Note that when the MAV filter is processing data, the STS bit and the corresponding DAV bits in the status register indicate that the converter is busy until all conversions necessary for the preprocessing are complete. The default state for these bits is 0000, which bypasses the preprocessor. These bits are the same whether reading or writing.
D9-D5	RESERVED	W	0	
D4-D1	MAVE	R/W	0000	MAV-filter function-enable bit When any bit is set to 1, the MAV filter setup is applied to the corresponding measurement.
D0	RESERVED	W	0	

7.6.1.4 Converter-Function Select Register (address = Fh) [reset = 0000h]

The converter-function select (CFN) register reflects the converter function select status.

图 41. Converter-Function Select Register

D15	D14	D13	D12	D11	D10	D9	D8
CFN[15:13]			RESERVED			CFN[8:0]	
R-0			R-0			R-0	
D7	D6	D5	D4	D3	D2	D1	D0
CFN[8:0]							
R-0							

表 14. Converter-Function Select Register Field Descriptions

Bit	Field	Type	Reset	Description
D15-D13	CFN[15:13]	R	0	Touch-screen driver status These bits represent the current status of the turned-on touch-screen drivers. The device sets CFN13 to 1 with both X+ and X- drivers turned on, CFN14 to 1 with both Y+ and Y- drivers turned on, and CFN15 to 1 with Y+ and X- drivers turned on. Otherwise, the device sets these bits to 0. The device resets these bits to 000b whenever the converter function is complete, stopped by the STS bit, or reset (by a hardware reset from the <u>RESET</u> pin or a software reset from SWRST bit in control byte 1).
D12-D9	RESERVED	R	0	
D8-D0	CFN[8:0]	R	0	Converter function-select status. These bits represent the converter function currently running, which is set in bits C3–C0 of control byte 1. When the CFNx bit shows 1, where x is the decimal value of converter function-select bits C3–C0, it is an indication that the converter function set in bits C3–C0 is running. For example, when CFN2 shows 1, it indicates the converter function set in bits C3–C0 (0010) is running. Reset of the CFNx bits to 0000h occurs whenever the converter function is complete, stopped by STS bit, or reset (by the hardware reset from the <u>RESET</u> pin or the software reset from SWRST bit in Control Byte 1). However, if the TSC sets the PSM bit in the CFR0 register to 1 to initiate the scan-function mode, reset of the CFN0 or CFN1 does not occur when the corresponding converter function is complete, because there is no pen touch. This event allows the TSC2013-Q1 to initiate the scan process (corresponding to CFN0 or CFN1 set to 1) immediately on detection of the next pen touch.

7.6.1.5 Status Register (address = 8h) [reset = 0004h]

The Status Register provides information about the TSC2013-Q1 status.

图 42. Status Register

D15	D14	D13	D12	D11	D10	D9	D8
DAV Due X TRIPLET	DAV Due Y TRIPLET	DAV Due Z1	DAV Due Z2	DAV Due AUX	RESERVED		
R-0				R-0			
D7	D6	D5	D4	D3	D2	D1	D0
RESET Flag	RESERVED				PDST	RESERVED	
R-0	R-0				R-1	R-0	

表 15. Status Register Field Descriptions

Bit	Field	Type	Reset	Description
D15-D11	DAV	R	0	<p>Data available bits</p> <p>These five bits mirror the operation of the internal signals of DAV. On storing any processed data in data registers, the DAV bit (D15 to D11) corresponding to the data type is set to 1. The bit stays at 1 until the registers updated to the host has read out the processed data. If the user submits a single I_X or single I_Y conversion command, bit D15 or D14 (respectively) shows data availability. In this case, only data register I_X or I_Y receives an update.</p> <p>0: No new processed data are available. 1: Processed data are available. This bit remains at 1 until the host has read out all updated registers.</p>
D10-D8	RESERVED	R	0	
D7	RESET	R	0	<p>Interpretation of the RESET flag bits:</p> <p>0: Device was reset since the last status poll (hardware or software reset). 1: Device reset has not occurred since the last status poll.</p>
D6-D3	RESERVED	R	0	
D2	PDST	R	1	<p>Power-down status</p> <p>This bit reflects the setting of the PND0 bit in Control Byte 0. When this bit shows 0, it indicates ADC bias circuitry power is still on after each conversion and before the next sampling; otherwise, it indicates ADC bias circuitry power is down after each conversion and before the next sampling. However, power is down between conversion sets. Because this status bit is in synchrony with the internal clock, it does not reflect the setting of the PND0 bit until detection of a pen touch is detected or initiation of a converter function.</p>
D1-D0	RESERVED	R	0	

7.6.2 Data Registers

The data registers of the TSC2013-Q1 hold data results from conversions. All of these registers default to 0000h on reset.

7.6.2.1 X1, X2, IX, Y1, Y2, IY, Z1, Z2, and AUX registers (offset = see 表 10) [reset = see 表 10]

The results of all ADC conversions are placed in the appropriate data registers, as described in 表 9. The data format of the result word (R) of these registers is right-justified, as shown in .

图 43. X1, X2, IX, Y1, Y2, IY, Z1, Z2, and AUX Registers

D15	D14	D13	D12	D11	D10	D9	D8
RESERVED				R11 ⁽¹⁾	R10 ⁽¹⁾	R9	R8
R-0				R-0	R-0	R-0	R-0
D7	D6	D5	D4	D3	D2	D1	D0
R7	R6	R5	R4	R3	R2	R1	R0
R-0	R-0	R-0	R-0	R-0	R-0	R-0	R-0

(1) R11 and R10 are 0 in 10-bit mode.

表 16. X1, X2, IX, Y1, Y2, IY, Z1, Z2, and AUX Register Field Descriptions

Bit	Field	Type	Reset	Description
D15-D12	RESERVED	R	0	Use of the D15 bit only occurs during a single IX or single IY conversion command (see 表 10). T = 0: No touch detected during conversion T = 1: Touch detected during conversion
D11-D0	R[11:0]	R	0	12-bit data

8 Application and Implementation

8.1 Application Information

8.1.1 Auxiliary Measurement

The TSC2013-Q1 device can measure the voltage from the auxiliary input (AUX). Applications for the AUX can include external temperature sensing, ambient light monitoring for controlling backlighting, or sensing the current drawn from batteries. Two converter functions can be used for the measurement of the AUX:

1. Non-continuous AUX measurement as shown in 图 44 (converter function select bits C[3:0] = control byte 1 D[6:3] = 0101)
2. Continuous AUX measurement as shown in 图 45 (converter function select bits C[3:0] = control byte 1 D[6:3] = 1000)

See 表 7 for more information on the converter function select bits.

Use 公式 9 to calculate the time required to make a non-continuous auxiliary measurement.

$$t_{(\text{COORDINATE})} = \frac{t_{(\text{OH}3)}}{f_{(\text{OSC})}} + N \times \left((B + 2) \times \frac{f_{(\text{OSC})}}{f_{(\text{ADC})}} + t_{c(\text{OH})} \right) \times \left(\frac{1}{f_{(\text{OSC})}} \right) + \left(\frac{t_{(\text{PPRO})}}{f_{(\text{OSC})}} \right)$$

where

- $t_{(\text{OH}3)}$ = overhead time number 3 = 3.5 internal clock cycles. (9)



图 44. Non-Touch Screen, Non-Continuous AUX Measurement

Use 公式 9 to calculate the time required to make a continuous auxiliary measurement.

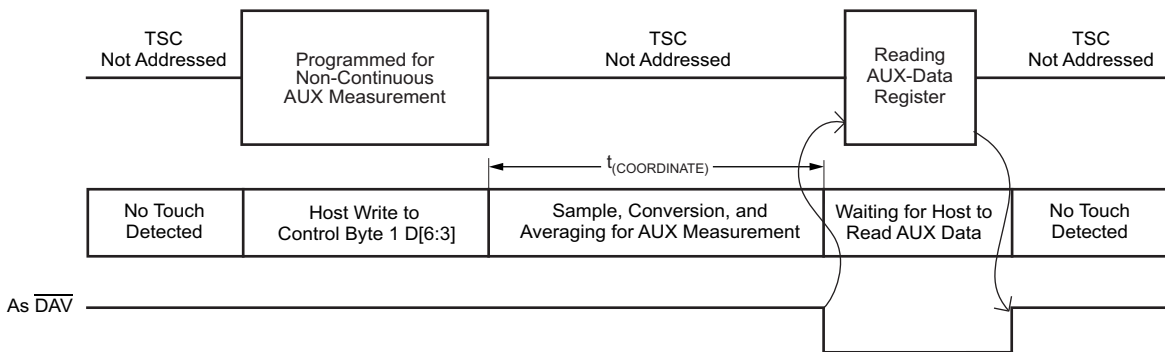

图 45. Non-Touch Screen, Continuous AUX Measurement

8.1.2 Single IX or Single IY Measurement

图 46 shows the sequence for a single IX or single IY measurement.

Application Information (接下页)

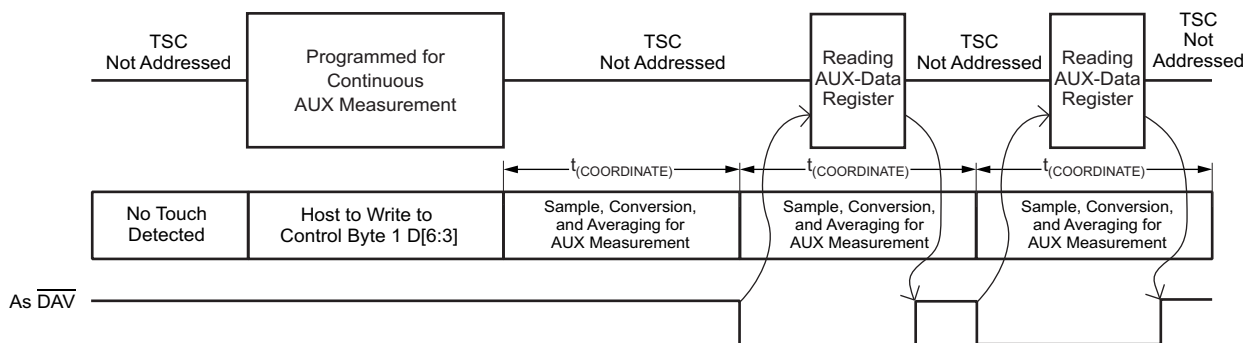

图 46. Touch Screen, Single IX or IY Measurement

8.2 Typical Application

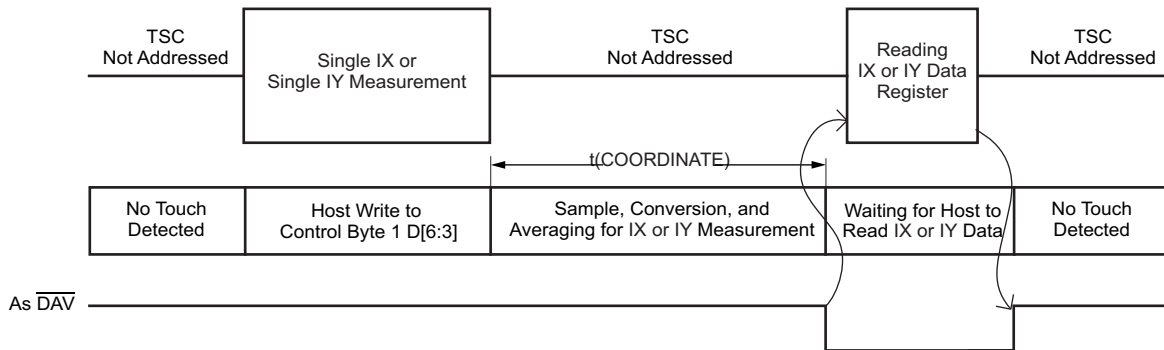

图 47. Typical Application Diagram

8.2.1 Design Requirements

The system-level requirements for this design include:

- Normal 4-wire resistive touch screen with low activation force (from center area down to 0.1 to 0.3 N) to enable smooth dual-touch operation.
- The $R_{(SENSE)}$ resistor value is the lowest panel resistance (X or Y layer) which is approximately 4.5. This resistor value provides the best dynamic range for dual-touch separation.
- To achieve the best possible SNR, select the highest operating voltage of the TSC2013-Q1 device that is compatible with the system.

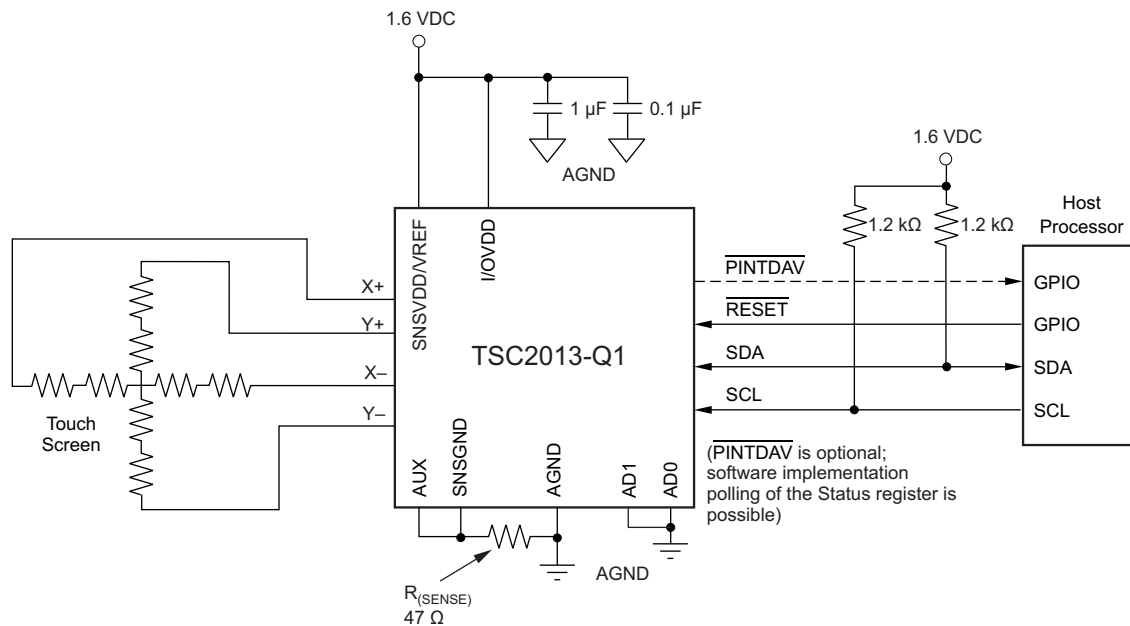
8.2.2 Detailed Design Procedure

Resistive dual touch using TSC2013-Q1 device is based on the principle of measuring resistance changes between X and Y panel. The resistive touch screen has two ITO layers which are located apart from each other. When the user uses a single-finger touch, only a minor parallel connection occurs between these two layers.

Typical Application (接下页)

During a dual-finger touch when the finger touches are located on different areas of the screen, parallel connection is much higher which results in a reduction in panel resistance. Because the TSC2013-Q1 device measures both X and Y-layer panel resistance, the finger touch distance can be easily calculated from the resistance change. This calculation is achieved by using one external resistor the is connected internally in series with the measured X-Y panel.

Use the following methods to enable the dual-touch function of the TSC2013-Q1 device:

- Measure all four nodes and use those measurements to calculate center point of the finger touch.
- Use the measurements of the four nodes to correctly place the touch positions to the correct quadrants.
- Measure the two-layer panel resistance by using a single external resistor that is connected internally in series with measured panel layer. A change in resistance is interpreted as a change in finger distance.

All calculations are performed by the host-side processor. The TSC2013-Q1 device provides only data.

The following sections describe the design procedure in detail.

8.2.2.1 Power-On-Reset and Reset Consideration

The TSC2013-Q1 device can be rest to the default working state in one of three ways. These resets are: power-on reset (see the [Power-On Reset](#) section), hardware reset (see the [Hardware Reset](#) section), and software reset (see the [Software Reset](#) section).

The requirements for ensuring a proper TSC2013-Q1 power-on reset (POR) are very stringent and can be very hard to meet in many applications. To workaround this issue, users should apply a proper hardware or software reset, instead of or in addition to the POR.

8.2.2.1.1 Power-On Reset

Based on design principles and extensive tests with TSC2013-Q1 device, the power of the device must meet a specific on-off timing and sequence to ensure the POR is implemented during each TSC2013-Q1 power on. This specific timing and sequence also ensures that a lockup is prevented.

During the device power on, the POR brings the TSC2013-Q1 device into a known default working state by initializing the internal state machine, data and control registers, and the condition of the output pins. Without the POR, the TSC2013-Q1 device can power on in a random state and can cause the PINTDAV pin to respond incorrectly.

The TSC2013-Q1 POR circuit was designed to not consume power during normal operation. The power-down current is kept as low as possible (0.8- μ A maximum power-down supply current).

This POR circuit in TSC2013-Q1 device requires specific power-up and power-down ramps and sequences.

Figure 48 shows and Table 17 lists the recommended power-off times, on-ramp, and off-ramp specifications.

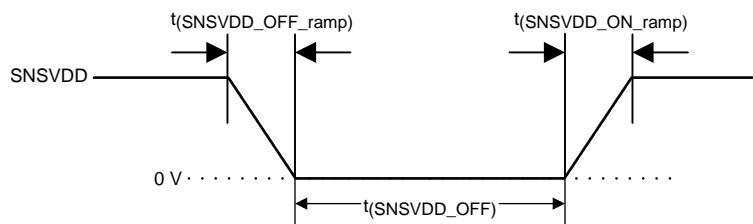

Figure 48. POR Sequence

Table 17. Requested POR Timings

TEMPERATURE RANGE	MINIMAL $t_{(SNSVDD_OFF_ramp)}$	MINIMAL $t_{(SNSVDD_ON_ramp)}$	MINIMAL $t_{(SNSVDD_OFF)}^{(1)}$
-40°C to -21°C	12 kV/s	12 kV/s	1.2 s
-20°C to 85°C	2 kV/s	12 kV/s	200 ms

(1) $t_{(SNSVDD_OFF)}$ time begins when the SNSVDD pin voltage reaches and stays at 0 V.

8.2.2.1.2 Requesting a Minimal $t_{(SNSVDD_OFF)}$ Time

The POR circuit of the TSC2013-Q1 device contains a capacitor that is charged when the device powers up which generates an internal reset signal. This capacitor is discharged after the TSC2013-Q1 supply is switched off. The TSC2013-Q1 device is designed for low-power operation, therefore the POR requires time to charge and discharge the capacitor, especially under cold temperatures (less than -20°C). If the SNSVDD off time is not sufficient, the device can lock up. Only a power recycle can resolve this lockup condition.

8.2.2.1.3 Requesting a Minimal $t_{(SNSVDD_OFF_ramp)}$ and $t_{(SNSVDD_ON_ramp)}$ Ramp

To ensure proper initialization of the TSC2013-Q1 device, the device must reach a certain voltage before the internal POR signal is released. If the power supply on the ramp is too slow the device can power up in a random state which can cause a lock up.

The capacitor inside the POR circuit must be discharged through the SNSVDD pin. To support a proper discharge when the TSC2013-Q1 supply is switched off, TI recommends to provide a low resistance path on the SNSVDD pin.

8.2.2.1.4 Hardware Reset

The hardware reset pin, $\overline{\text{RESET}}$, is available to perform a system reset which resets the device if the pulse width meets the timing requirement (at least $10\text{-}\mu\text{s}$ wide and the SNSVDD/VREF or I/OVDD pin is greater than or equal to 1.6 V). Any reset pulse less than $5\text{ }\mu\text{s}$ is rejected. To accommodate the timing drift between devices because of process variation, a reset pulse width between $5\text{ }\mu\text{s}$ and $10\text{ }\mu\text{s}$ is not recognized and the result is undetermined. This situation should be avoided. A good reset pulse must be low for at least $10\text{ }\mu\text{s}$ (SNSVDD/VREF or I/OVDD pin is greater than or equal to 1.6 V). An internal spike filter rejects spikes up to 20 ns wide. See [Figure 37](#) for the hardware reset timing diagram.

8.2.2.1.5 Software Reset

During normal operation a software reset can be sent by the host processor to the device by setting the SWRST bit (D1) to 1 in the control byte 1 (see [Table 6](#)).

8.2.2 Power Up Considerations

8.2.2.2.1 Power-Off Cycles During Normal Operation

The TSC2013-Q1 device is a low-power device and therefore switching the TSC2013-Q1 device off during normal operation is not needed nor recommended.

Every power cycle (power on \rightarrow power off \rightarrow power on) must meet the requirements described in the [Power-On Reset](#) section. If requirements cannot be met, TI recommends to issue a hardware reset after every power cycle.

8.2.2.2.2 Supply Glitches During Normal Operation

A TSC2013-Q1 SNSVDD or IOVDD power glitch during normal operation can cause a lockup condition. Therefore ensure that the system is able to either recycle the power in the system following the requirements described in the [Power-On Reset](#) section or issue a hardware reset as described in the [Hardware Reset](#) section.

8.2.2.2.3 TSC2013-Q1 Digital Pins

In many applications, users use the same power supply for both the TSC2013-Q1 analog and digital supplies. The SNSVDD supply is connected with the I/OVDD supply. Under such cases, the logic high status on the TSC2013-Q1 digital pins before power-up become a concern when performing a proper POR.

Table 18 lists the digital I/O pins of the TSC2013-Q1 device.

Table 18. TSC2013-Q1 Digital Pin List

TSC2013-Q1 PINS	DESCRIPTION
$\overline{\text{PINTDAV}}$	Digital Output. Data available or the pen-detect interrupt (PENIRQ), depending on setting. Pin polarity is active-low.
$\overline{\text{RESET}}$	Digital input. External hardware reset input (active-low).
SCL	Open drain and collector. Serial clock
SDA	Open drain and collector. Serial data I/O
A0	Digital input. I ² C bus TSC address input bit 0
A1	Digital input. I ² C bus TSC address input bit 1

Every TSC2013-Q1 pin is well protected against ESD strikes. The TSC2013-Q1 $\overline{\text{RESET}}$, A0, and A1 pins have the same protection as the SDA and SCL pins. This protection allows the $\overline{\text{RESET}}$, A0, and A1 pins to be pulled high before the device powers on without activating an internal ESD diode and without causing a power up of the TSC2013-Q1.

The output pin, $\overline{\text{PINTDAV}}$, is a digital output pin. The host processor must define the $\overline{\text{PINTDAV}}$ pin as an input to the host processor without any pullup-pulldown feature. In some cases the default of the host processor is an output with an enabled pullup-pulldown feature but the host-processor firmware changes this definition at a later point to an input. If the TSC2013-Q1 device is not powered up, a power up can also occur through the ESD cells as shown in by the red line in Figure 49. This power up is considered a *false* power up. A false power up cannot ensure a proper power supply to the device or a proper POR.

In case the TSC2013-Q1 device is powered up, both the device and drive processor drive different levels on the same line resulting in high power consumption.

The TSC2013-Q1 $\overline{\text{PINTDAV}}$ pin should be connected to the correct pin on the host processor to avoid bus conflicts and illegal powering up of the TSC2013-Q1 device.

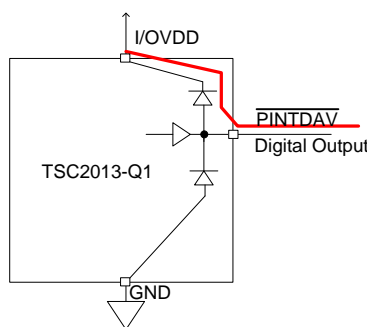

Figure 49. Internal ESD Protection Diodes at the TSC2013-Q1 $\overline{\text{PINTDAV}}$ Pin

8.2.2.2.4 Suggested Hardware Reset During Power-On

The suggested sequence during power up is the following:

- Keep $\overline{\text{RESET}}$ pin low
- Wait for the supplies to settle
- Wait for at least 10 μ s before releasing the $\overline{\text{RESET}}$ pin

Figure 50 shows the suggested waveform.

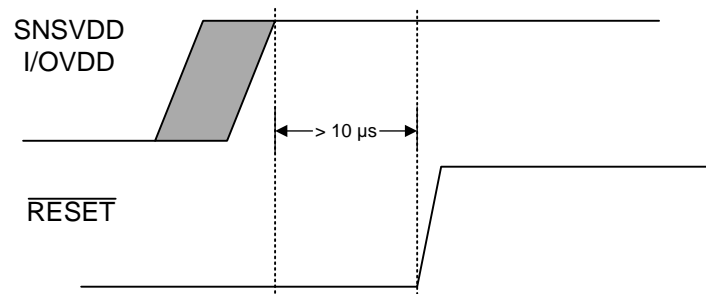

Figure 50. Suggested $\overline{\text{RESET}}$ Waveform During Power-On

8.2.2.3 Device Timing Setup and Use

The TSC2013-Q1 device is a register-based touch-screen controller (TSC). This section describes the setup and use of the programable timings available in the TSC2013-Q1 device.

Figure 52 through Figure 56 in the *Application Curves* were generated to show the principal. The TSC2013-Q1 X triplet contains X1, X2, and IX conversions. The TSC2013-Q1 Y triplet contains Y1, Y2, and IY conversions. The TSC2013-Q1 Z measurement contains Z1 and Z2 conversions.

8.2.2.3.1 Touch-Panel Driving Power

On a resistive touch-screen system, the driving current of the touch panel, provided by the TSC device through the analog interface, has the highest impact on the power consumption in the touch screen system. This touch-panel power consumption is decided by the resistance of the touch panel and the TSC power-supply (SNSVDD) voltage. Figure 51 shows this relationship. The touch screen is driven by the TSC from the SNSVDD supply and the resistance of the panel determines the peak drive current.

Figure 51 only shows the ideal TSC driving condition where the internal resistance of the TSC is ignored because the resistance is small (5 to 6 Ω) compared to the resistance of the touch panel (100s to 1000s Ω). Therefore the actual power consumption should be a little less than that shown in Figure 51.

A user can reduce power consumption in three ways:

- Using touch screens with higher resistance
- Using a low-power supply, SNSVDD, to the TSC
- Reducing the driver on-time or the on-off ratio of the driver

Touch panels with higher resistance are likely to cause more noise and longer settling time which limits the options for users.

The TSC2013-Q1 device is designed with a power supply, SNSVDD, range of 1.6 V to 3.6 V.

Reducing the driver on-time involves setting various touch-screen timings and delays. lists the relevant parameters concerning these timings and delays. The following sections describe the functions and effects of these timings and delays. See the *Register Maps* section for the timing settings of the configuration registers.

8.2.2.3.2 ADC Clock Effects

A TSC2013-Q1 device contains a nominal 4-MHz internal clock that is used to drive the state machines inside the device which performs the many functions. This clock is divided down to provide a clock to run the SAR ADC (analog-to-digital converter). If the 4-MHz clock is used directly (divided by 1), the ADC is limited to a 10-bit resolution, then using higher resolutions at this speed does not result in accurate conversions. The 12-bit resolution requires that the conversion clock run at either 2 MHz (divided by 2) or 1 MHz (divided by 4). The division ratio for the ADC clock is set in the configuration register 0 (CFR0), by setting the CL1 and CL0 bits (see Table 6).

The ability to change the conversion clock rate allows the user to select the optimal value for the ADC resolution, speed, and power dissipation. Higher clock frequency results in faster touch-data converting speed and shorter touch-driver on-time which usually result in lower SNSVDD power consumption. [Figure 52](#) and [Figure 53](#) show examples of the ADC clock effect on the analog interface traffic (X+, X–, Y+, and Y– lines). In these figures, a TSC drives the touch panel to acquire the X, Y, Z1, and Z2 coordinates and three samples-per-coordinate. [Figure 52](#) shows an analog interface with the clock frequency set to 2 MHz. [Figure 53](#) shows an analog interface with the clock frequency set to 1-MHz. In [Figure 52](#) and [Figure 53](#), other than the ADC clock frequency difference, all other settings are completely identical with the following values: PVS equal to 0 μs, PR equal to 20 μs, and SN equal to 32 μs (see the [Panel Voltage Stabilization Time](#) section for more information on these timers).

The ADC clock frequency determines the length of the TSC acquisition time and TSC driver on-time. The faster the ADC clock, the shorter the driver on-time. For example, sampling 3 Y data with an ADC clock value of 2 MHz (see [Figure 52](#)) uses only about half of the time compared to sampling the data with an ADC clock value of 1 MHz (see [Figure 53](#)).

Use [Equation 10](#) to calculate the analog power-supply current, $I_{(SNSVDD)}$.

$$I_{(SNSVDD)} = f(V_{(SNSVDD)}) + \left(\frac{V_{(SNSVDD)}}{R} \right) \times \left(\frac{SSPS \times S \times B}{f_{(OSC)}} \right)$$

where

- $f(V_{(SNSVDD)})$ is a function of $V_{(SNSVDD)}$
- $V_{(SNSVDD)}$ is the SNSVDD voltage (in V)
- R is the average resistance of the touch panel (in Ω)
- SSPS is sample sets-per-second, which indicates how many sets of touch data is received by the host within a second
- S is the number of data in a set of samples
- B is the TSC resolution, either 10 bit or 12 bit
- $f_{(OSC)}$ is ADC clock frequency, which can be 4, 2, or 1 MHz

(10)

[Equation 10](#) includes two parts: the internal circuitry power consumption or $f(V_{(SNSVDD)})$ and the current to drive the external resistive-touch panel which is calculated using [Equation 11](#).

$$I_{(TOUCH-PANEL)} = \left(\frac{V_{(SNSVDD)}}{R} \right) \times \left(\frac{SSPS \times S \times B}{f_{(OSC)}} \right)$$

(11)

A concern for using the faster ADC clock is because of the settling time or transients of the analog interface. The higher clock frequency can reduce the accuracy of the data in those cases where the TSC begins the data acquisitions before the analog interface lines reach the stable voltages. Therefore, adding some delays on the analog interface in order to wait for the interface to become stable before an ADC begins working might be necessary. These delays can include the panel voltage-stabilization time, the precharge time of the pins, the sense time (see the [Panel Voltage Stabilization Time](#) section), or a combination.

8.2.2.4 Panel Voltage Stabilization Time

The panel voltage-stabilization time, $t_{d(PVS)}$, specifies a delay time from the moment the touch screen drivers are enabled to the time the voltage is sampled and a conversion is started. These bits allow the user to adjust the appropriate settling time for the touch panel based on the external capacitances at the analog interface lines.

[Figure 54](#) shows examples where with $t_{d(PVS)}$ is 0 μs (no PVS delay), 100 μs, and 500 μs. In the examples, the TSC uses the sets of $4 \times 3 = 12$ data which are 3 X, 3 Y, 3 Z1, and 3 Z2. The TSC2013-Q1 device always performs the Y coordinate first when it was set to X-Y or X-Y-Z scan mode. The sequence for receiving a set of samples in [Figure 54](#) is as follows:

1. The TSC adds driver power to Y+ (SNSVDD) and Y– (AGND), waits $t_{d(PVS)}$ μs, and acquires 3 Y data
2. The TSC adds driver power to X+ (SNSVDD) and X– (AGND), waits $t_{d(PVS)}$ μs, and acquires 3 X data
3. The TSC adds driver power to Y+ (SNSVDD) and X– (AGND), waits $t_{d(PVS)}$ μs, and acquires 3 Z1 and 3 Z2 data

The PVS delay consumes power because a driver is on during the PVS delay. Use [Equation 12](#) to calculate the power.

$$P = \left(\frac{V_{(SNSVDD)}}{R} \right) \times \text{SSPS} \times t_{d(\text{PVS})} \times 3$$

where

- 3 indicates that the X, Y, and Z drivers are on (12)

Based on [Equation 10](#), use [Equation 13](#) to calculate a complete expression of the analog power consumption for X-Y-Z 3-dimension coordinates.

$$P = f(V_{(SNSVDD)}) + \left(\frac{V_{(SNSVDD)}}{R} \times \text{SSPS} \times \left[\frac{S \times B}{F} + 3 \times t_{d(\text{PVS})} \right] \right)$$
(13)

Use [Equation 14](#) to calculate the power consumption for X-Y 2-dimension touch data.

$$P = f(V_{(SNSVDD)}) + \left(\frac{V_{(SNSVDD)}}{R} \times \text{SSPS} \times \left[\frac{S \times B}{F} + 2 \times t_{d(\text{PVS})} \right] \right)$$

where

- 2 indicates that the X and Y drivers are on (14)

8.2.2.5 Precharge and Sense Time

Unlike the ADC clock frequency (bits CL1 to CL0) and panel voltage-stabilization time (bits PV2 to PV0), the other two TSC timings in the CFR0 register (see [表 6](#)) affect the bus shape and traffic speed but do not effect power consumption of the analog interface.

As shown in [图 54](#), some added time or delays occur between samples of two coordinates such as after sampling Y and before the X driver turns on. This added time or delay is the precharge time (bits PR2 to PR0) and sense time (bits SN2 to SN0).

The precharge time sets the amount of time allowed for precharging any pin capacitance on the touch screen during TSC ADC conversions as shown in [图 55](#).

The sense time sets the amount of delay for the TSC device to wait between two coordinates during TSC ADC conversions as shown in [图 56](#).

If a pressure remains on the touch panel, the TSC devices can automatically and continuously acquire touch data. As many as several-thousand SSPS of touch data can be driven on, sampled, converted, and processed. For a typical application, however, users usually need only 100 to 500 SSPS of touch data because of the control and response limits of a human. To save power, users often do not want the system to acquire any unnecessary data.

The SSPS of a TSC can be reduced in several ways, including:

- Using the batch delay to add waiting time between the sets of touch data
- Inserting delays, such as PR and SN (but not PVS), to slow down the coordinate samples within a set because PR and SN do not consume power

See [表 6](#) for the bit locations and for the selectable time ranges.

8.2.2.6 Single-Touch Operation

The TSC2013-Q1 device can also be used only for single-touch operation. By measuring all 4-wire nodes (X+, X-, Y+, Y-) more-precise touch accuracy can be achieved compared to normal resistive TSCs.

TI advises to calculate the center point of the touch by using both node values. [Equation 15](#) shows an example.

$$X = 0.5 \times ([X+] - [X-]) + (X+) \quad (15)$$

This same calculation method is used on dual-touch middle-point calculation.

8.2.3 Application Curves

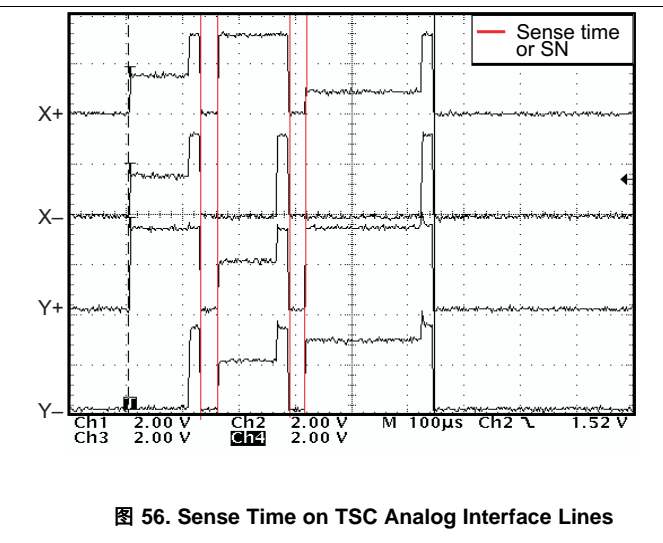
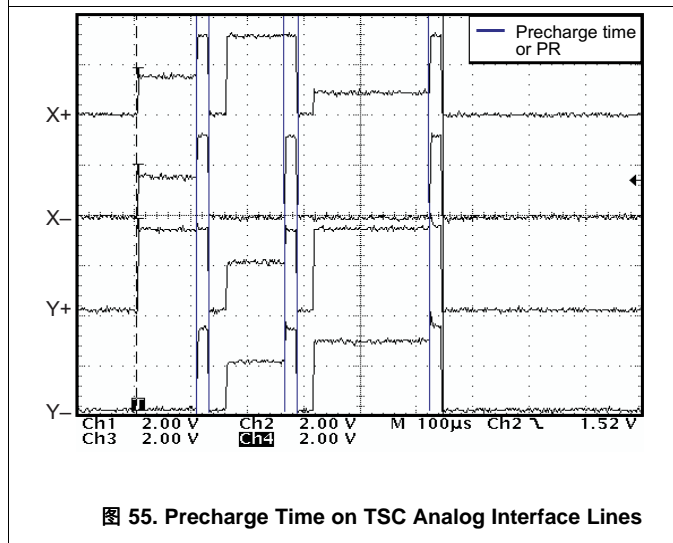
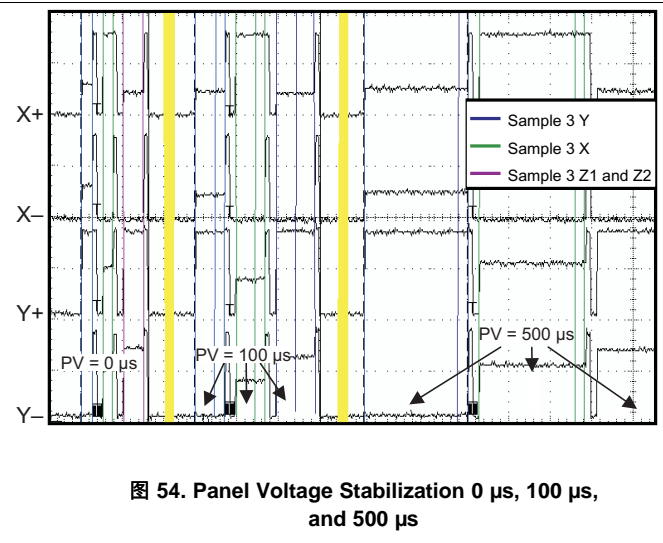
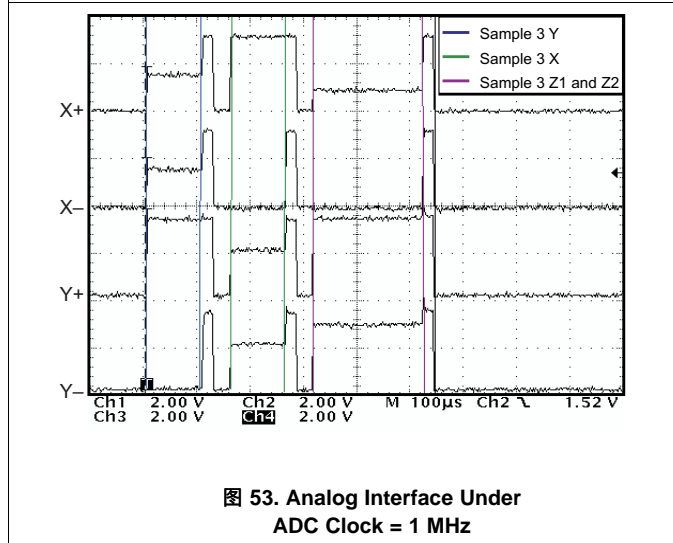
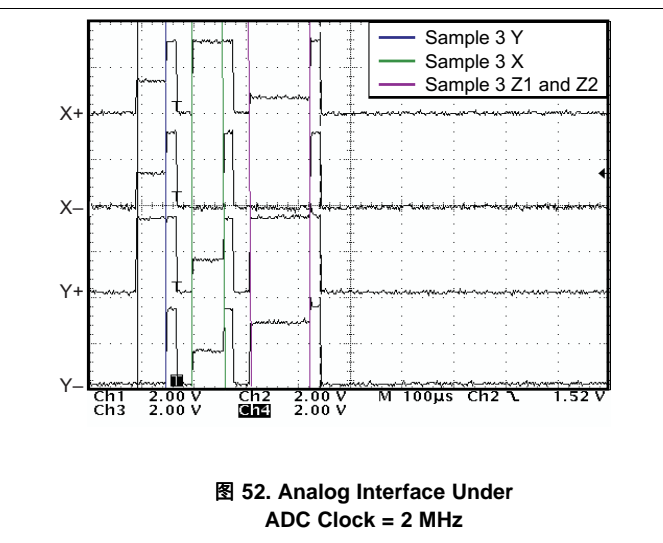
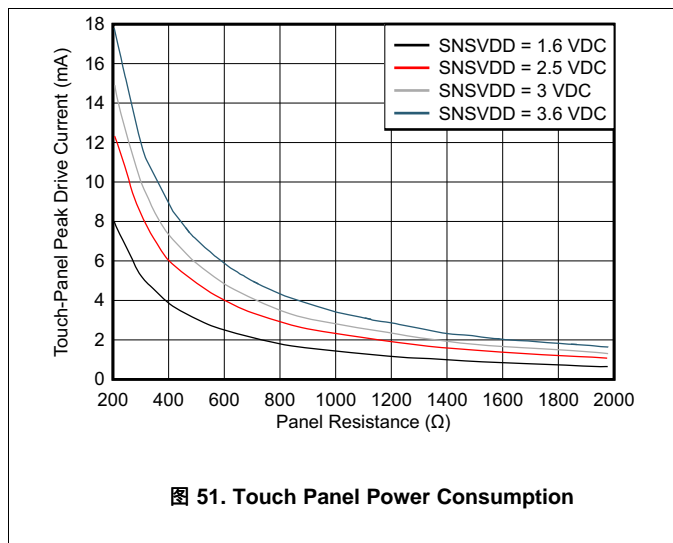

9 Power Supply Recommendations

The devices are designed to operate from an input voltage supply range between 1.6 V and 3.6 V. Power to the TSC2013-Q1 device should be clean and well-bypassed. Add a 0.1- μ F ceramic bypass capacitor between (SNSVDD and AGND) or (I/OVDD and AGND).

10 Layout

10.1 Layout Guidelines

The following layout suggestions should obtain optimum performance from the TSC2013-Q1 device. However, many portable applications have conflicting requirements for power, cost, size, and weight. In general, most portable devices have fairly clean power and grounds because most of the internal components are very low-power. This situation would mean less bypassing for the converter power and less concern regarding grounding. Still, each application is unique, so review the following suggestions carefully.

For optimum performance, take care with the physical layout of the TSC2013-Q1 circuitry. The basic SAR architecture is sensitive to glitches or sudden changes on the power supply, reference, and ground connections, and digital inputs that occur just prior to latching the output of the analog comparator. Therefore, during any single conversion for an n -bit SAR converter, there are n windows in which large external transient voltages can easily affect the conversion result. Such glitches might originate from switching power supplies, nearby digital logic, and high-power devices. The degree of error in the digital output depends on the reference voltage, layout, and the exact timing of the external event. The error can change if the external event changes in time with respect to the SCL input.

With this in mind, power to the TSC2013-Q1 device should be clean and well-bypassed. Add a 0.1- μ F ceramic bypass capacitor between (SNSVDD and AGND) or (I/OVDD and AGND). The circuit also requires a 0.1- μ F decoupling capacitor between SNSVDD/VREF and AGND. Place these capacitors as close to the device as possible. The circuit may also require a 1- μ F to 10- μ F capacitor if the impedance of the connection between SNSVDD/VREF and the power supply is high. Short I/OVDD to the same supply plane as SNSVDD/VREF. Short both SNSVDD/VREF and I/OVDD to the analog power-supply plane.

The ADC architecture offers no inherent rejection of noise or voltage variation in regards to using an external reference input, which is of particular concern when the reference input is tied to the power supply for auxiliary input. Any noise and ripple from the supply appears directly in the digital results. While high-frequency noise can be filtered out by the built-in MAV filter, voltage variation as a result of line frequency (50 Hz or 60 Hz) can be difficult to remove. Avoid any active trace going under the analog pins listed in the table without shielding them by a ground or power plane.

Connect the AGND pin to a clean ground point. In many cases, this connection will be the *analog* ground. Avoid connections that are too near the grounding point of a microcontroller or digital signal processor. If needed, run a ground trace directly from the converter to the power-supply entry or battery-connection point. The ideal layout includes an analog ground plane dedicated to the converter and associated analog circuitry.

In the specific case of use with a resistive touch screen, take care with the connection between the converter and the touch screen. Because resistive touch screens have fairly low resistance, the interconnection should be as short and robust as possible. Loose connections can be a source of error when the contact resistance changes with flexing or vibrations.

As indicated previously, noise can be a major source of error in touch-screen applications (for example, applications that require a backlit LCD panel). This electromagnetic interference (EMI) noise can be coupled through the LCD panel to the touch screen and cause flickering of the converted ADC data. One can do several things to reduce this error, such as using a touch screen with a bottom-side metal layer connected to ground, which couples the majority of noise to ground. Another way to filter out this type of noise is by using the TSC2013-Q1 built-in MAV filter (see the section). Filtering capacitors, from Y+, Y–, X+, and X– to ground, can also help. Note, however, that the use of these capacitors increases screen settling time and requires longer panel voltage stabilization times, and also increases precharge and sense times for the PINTDAV circuitry of the TSC2013-Q1 device. The resistor value varies depending on the touch-screen sensor used. The internal 50-k Ω pullup resistor ($R_{(IRQ)}$) may be adequate for most sensors.

10.2 Layout Example



图 57. TSC2013-Q1 Layout Example

11 器件和文档支持

11.1 商标

All trademarks are the property of their respective owners.

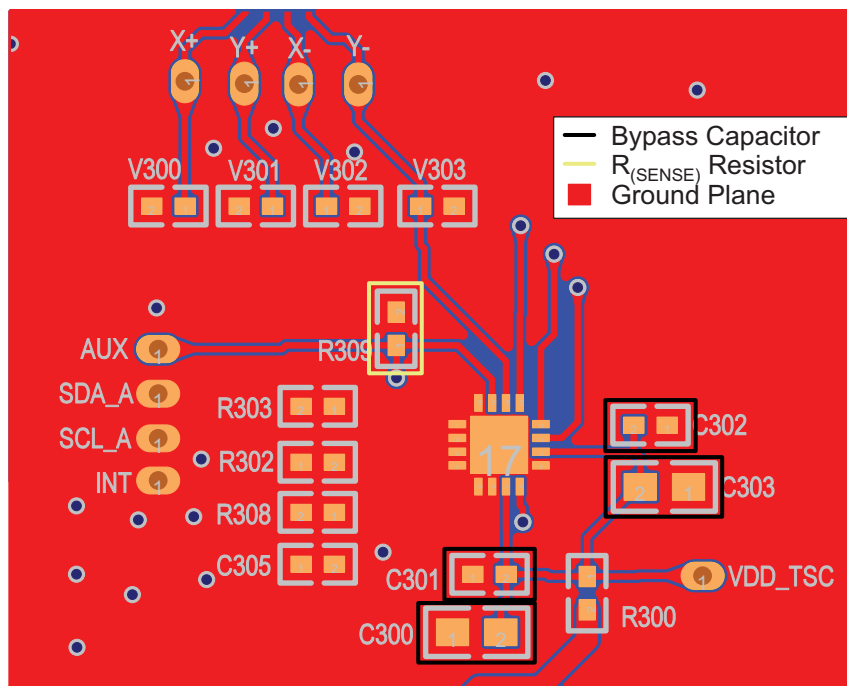
11.2 静电放电警告



这些装置包含有限的内置 ESD 保护。存储或装卸时，应将导线一起截短或将装置放置于导电泡棉中，以防止 MOS 门极遭受静电损伤。

11.3 术语表

[SLYZ022](#) — TI 术语表。

这份术语表列出并解释术语、首字母缩略词和定义。

12 机械封装和可订购信息

以下页中包括机械封装和可订购信息。 这些信息是针对指定器件可提供的最新数据。 这些数据会在无通知且不对本文档进行修订的情况下发生改变。 要获得这份数据表的浏览器版本，请查阅左侧导航栏。

PACKAGING INFORMATION

Orderable Device	Status (1)	Package Type	Package Drawing	Pins	Package Qty	Eco Plan (2)	Lead finish/ Ball material (6)	MSL Peak Temp (3)	Op Temp (°C)	Device Marking (4/5)	Samples
TSC2013QPWRQ1	ACTIVE	TSSOP	PW	16	2000	RoHS & Green	NIPDAU	Level-3-260C-168 HR	-40 to 125	TS2013Q	Samples
TSC2013QRSARQ1	ACTIVE	QFN	RSA	16	2500	RoHS & Green	NIPDAU	Level-2-260C-1 YEAR	-40 to 125	TSC 2013Q	Samples

(1) The marketing status values are defined as follows:

ACTIVE: Product device recommended for new designs.

LIFEBUY: TI has announced that the device will be discontinued, and a lifetime-buy period is in effect.

NRND: Not recommended for new designs. Device is in production to support existing customers, but TI does not recommend using this part in a new design.

PREVIEW: Device has been announced but is not in production. Samples may or may not be available.

OBSOLETE: TI has discontinued the production of the device.

(2) **RoHS:** TI defines "RoHS" to mean semiconductor products that are compliant with the current EU RoHS requirements for all 10 RoHS substances, including the requirement that RoHS substance do not exceed 0.1% by weight in homogeneous materials. Where designed to be soldered at high temperatures, "RoHS" products are suitable for use in specified lead-free processes. TI may reference these types of products as "Pb-Free".

RoHS Exempt: TI defines "RoHS Exempt" to mean products that contain lead but are compliant with EU RoHS pursuant to a specific EU RoHS exemption.

Green: TI defines "Green" to mean the content of Chlorine (Cl) and Bromine (Br) based flame retardants meet JS709B low halogen requirements of <=1000ppm threshold. Antimony trioxide based flame retardants must also meet the <=1000ppm threshold requirement.

(3) MSL, Peak Temp. - The Moisture Sensitivity Level rating according to the JEDEC industry standard classifications, and peak solder temperature.

(4) There may be additional marking, which relates to the logo, the lot trace code information, or the environmental category on the device.

(5) Multiple Device Markings will be inside parentheses. Only one Device Marking contained in parentheses and separated by a "-" will appear on a device. If a line is indented then it is a continuation of the previous line and the two combined represent the entire Device Marking for that device.

(6) Lead finish/Ball material - Orderable Devices may have multiple material finish options. Finish options are separated by a vertical ruled line. Lead finish/Ball material values may wrap to two lines if the finish value exceeds the maximum column width.

Important Information and Disclaimer: The information provided on this page represents TI's knowledge and belief as of the date that it is provided. TI bases its knowledge and belief on information provided by third parties, and makes no representation or warranty as to the accuracy of such information. Efforts are underway to better integrate information from third parties. TI has taken and continues to take reasonable steps to provide representative and accurate information but may not have conducted destructive testing or chemical analysis on incoming materials and chemicals. TI and TI suppliers consider certain information to be proprietary, and thus CAS numbers and other limited information may not be available for release.

In no event shall TI's liability arising out of such information exceed the total purchase price of the TI part(s) at issue in this document sold by TI to Customer on an annual basis.

TAPE AND REEL INFORMATION

QUADRANT ASSIGNMENTS FOR PIN 1 ORIENTATION IN TAPE

*All dimensions are nominal

Device	Package Type	Package Drawing	Pins	SPQ	Reel Diameter (mm)	Reel Width W1 (mm)	A0 (mm)	B0 (mm)	K0 (mm)	P1 (mm)	W (mm)	Pin1 Quadrant
TSC2013QPWRQ1	TSSOP	PW	16	2000	330.0	12.4	6.9	5.6	1.6	8.0	12.0	Q1
TSC2013QRSARQ1	QFN	RSA	16	2500	330.0	12.4	4.25	4.25	1.15	8.0	12.0	Q2

TAPE AND REEL BOX DIMENSIONS



*All dimensions are nominal

Device	Package Type	Package Drawing	Pins	SPQ	Length (mm)	Width (mm)	Height (mm)
TSC2013QPWRQ1	TSSOP	PW	16	2000	350.0	350.0	43.0
TSC2013QRSARQ1	QFN	RSA	16	2500	346.0	346.0	33.0

PW0016A

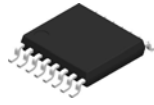

PACKAGE OUTLINE

TSSOP - 1.2 mm max height

SMALL OUTLINE PACKAGE



4220204/A 02/2017

NOTES:

1. All linear dimensions are in millimeters. Any dimensions in parenthesis are for reference only. Dimensioning and tolerancing per ASME Y14.5M.
2. This drawing is subject to change without notice.
3. This dimension does not include mold flash, protrusions, or gate burrs. Mold flash, protrusions, or gate burrs shall not exceed 0.15 mm per side.
4. This dimension does not include interlead flash. Interlead flash shall not exceed 0.25 mm per side.
5. Reference JEDEC registration MO-153.

EXAMPLE BOARD LAYOUT

PW0016A

TSSOP - 1.2 mm max height

SMALL OUTLINE PACKAGE



LAND PATTERN EXAMPLE
EXPOSED METAL SHOWN
SCALE: 10X



4220204/A 02/2017

NOTES: (continued)

- 6. Publication IPC-7351 may have alternate designs.
- 7. Solder mask tolerances between and around signal pads can vary based on board fabrication site.

EXAMPLE STENCIL DESIGN

PW0016A

TSSOP - 1.2 mm max height

SMALL OUTLINE PACKAGE



SOLDER PASTE EXAMPLE
BASED ON 0.125 mm THICK STENCIL
SCALE: 10X

4220204/A 02/2017

NOTES: (continued)

8. Laser cutting apertures with trapezoidal walls and rounded corners may offer better paste release. IPC-7525 may have alternate design recommendations.
9. Board assembly site may have different recommendations for stencil design.

GENERIC PACKAGE VIEW

RSA 16

VQFN - 1 mm max height

4 x 4, 0.65 mm pitch

PLASTIC QUAD FLATPACK - NO LEAD

This image is a representation of the package family, actual package may vary.
Refer to the product data sheet for package details.

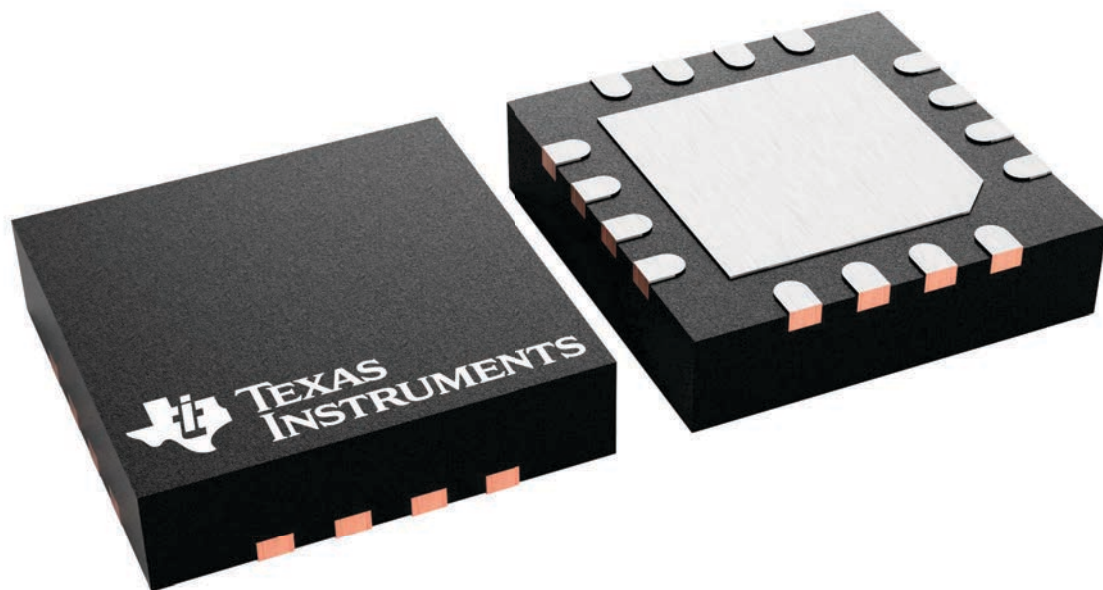

4230969/A

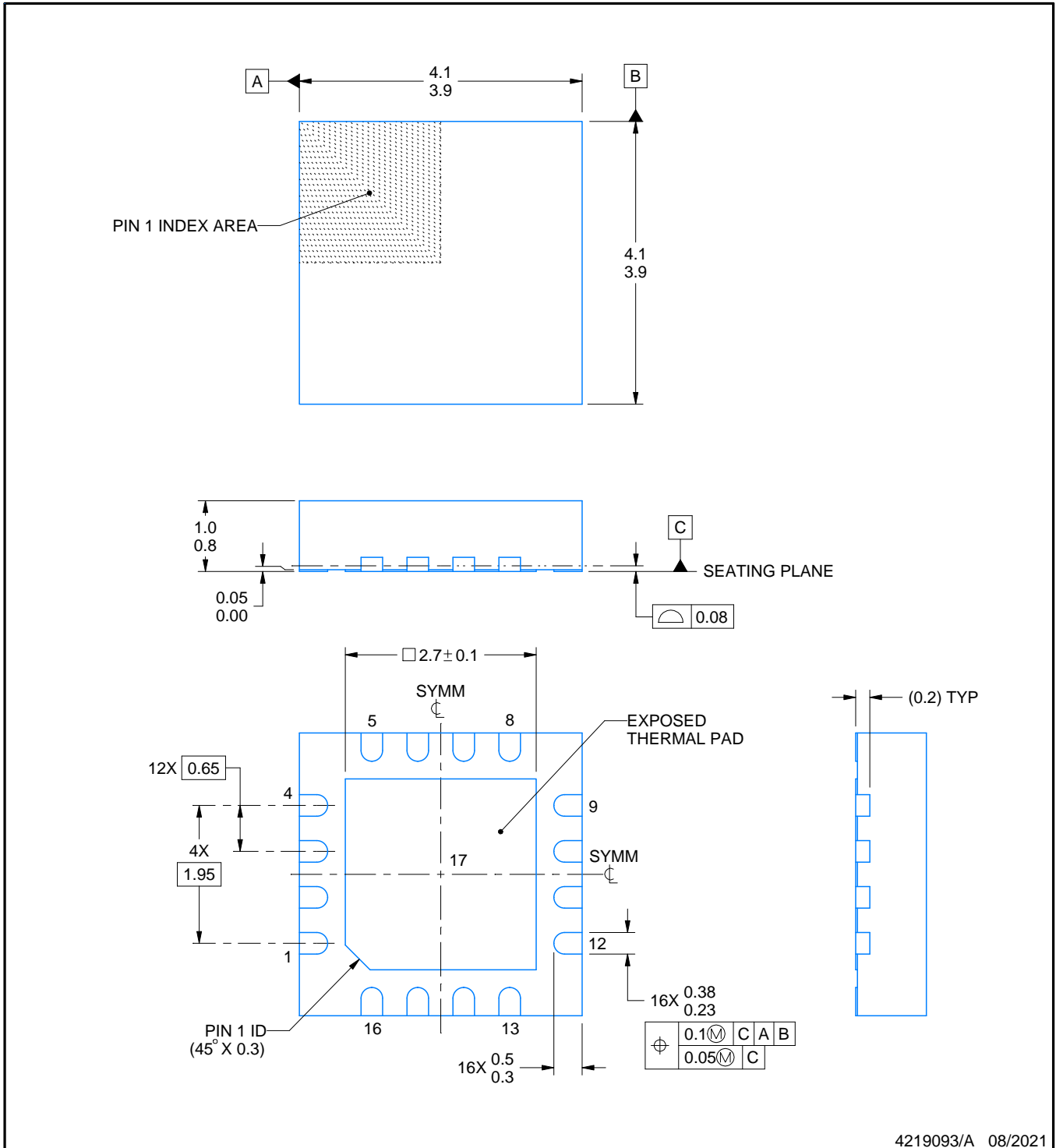
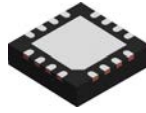

4219093/A 08/2021

NOTES:

1. All linear dimensions are in millimeters. Any dimensions in parenthesis are for reference only. Dimensioning and tolerancing per ASME Y14.5M.
2. This drawing is subject to change without notice.
3. The package thermal pad must be soldered to the printed circuit board for thermal and mechanical performance.
4. Reference JEDEC registration MO-220.

EXAMPLE BOARD LAYOUT

RSA0016B

VQFN - 1 mm max height

PLASTIC QUAD FLATPACK - NO LEAD

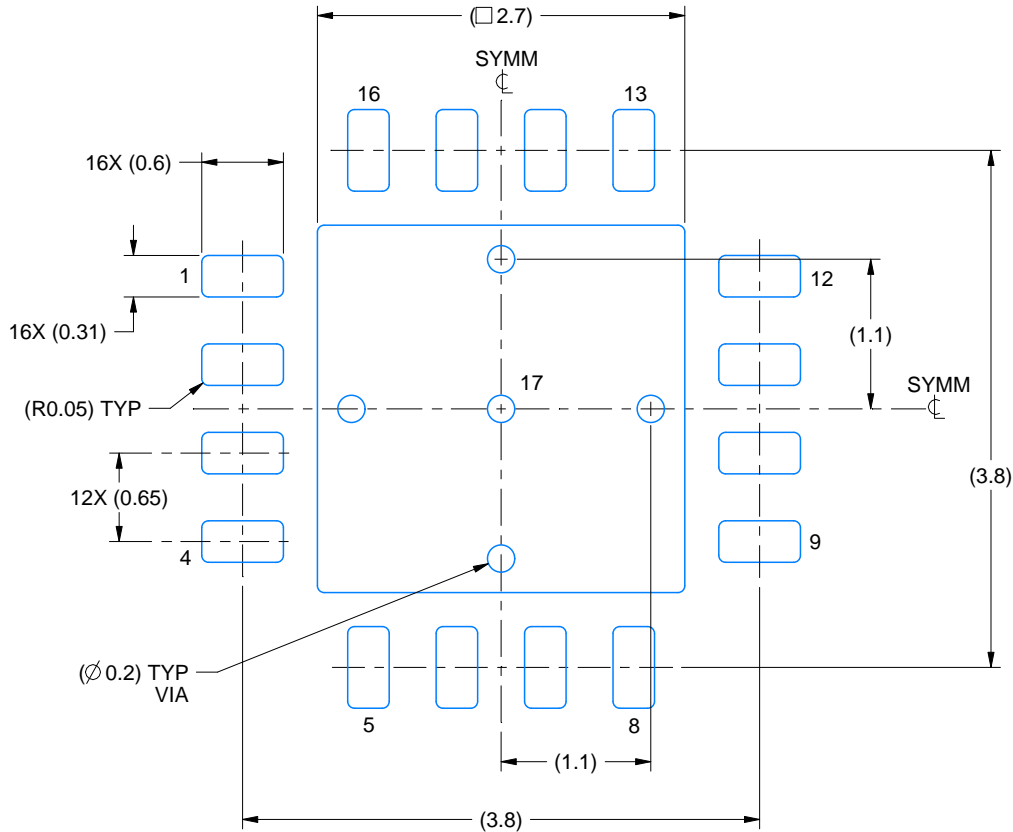

LAND PATTERN EXAMPLE
EXPOSED METAL SHOWN
SCALE:18X

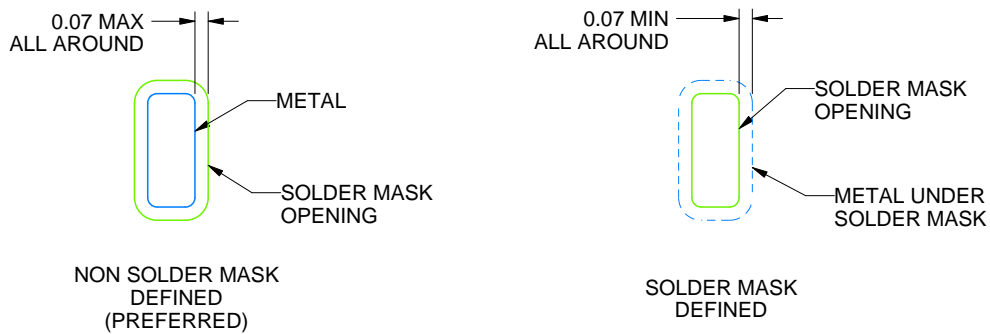

SOLDER MASK DETAILS

4219093/A 08/2021

NOTES: (continued)

5. This package is designed to be soldered to a thermal pad on the board. For more information, see Texas Instruments literature number SLUA271 (www.ti.com/lit/sluea271).
6. Vias are optional depending on application, refer to device data sheet. If any vias are implemented, refer to their locations shown on this view. It is recommended that vias under paste be filled, plugged or tented.

EXAMPLE STENCIL DESIGN

RSA0016B

VQFN - 1 mm max height

PLASTIC QUAD FLATPACK - NO LEAD

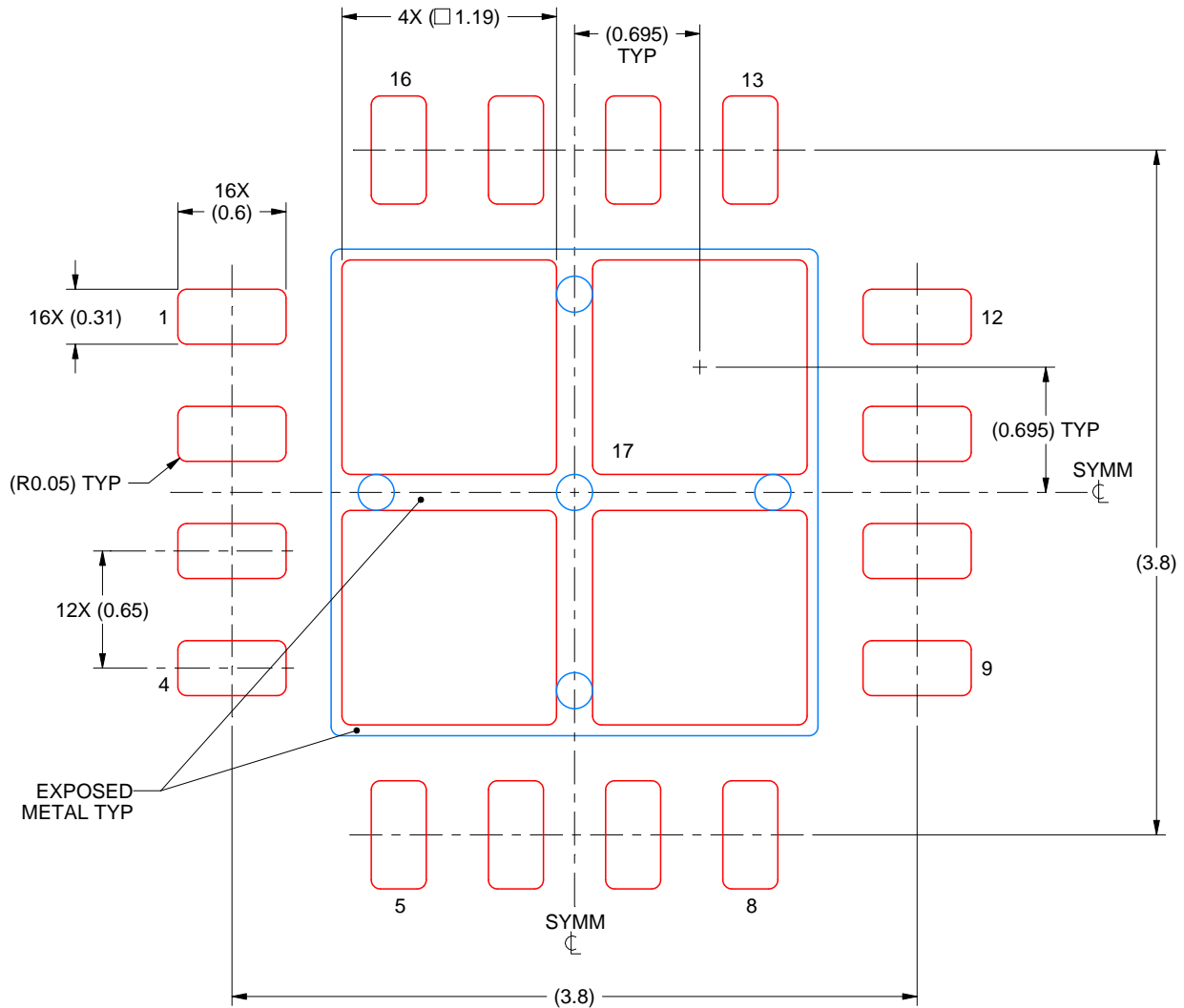

SOLDER PASTE EXAMPLE
BASED ON 0.125 mm THICK STENCIL

EXPOSED PAD
77% PRINTED SOLDER COVERAGE BY AREA
SCALE:25X

4219093/A 08/2021

NOTES: (continued)

7. Laser cutting apertures with trapezoidal walls and rounded corners may offer better paste release. IPC-7525 may have alternate design recommendations.

重要声明和免责声明

TI“按原样”提供技术和可靠性数据（包括数据表）、设计资源（包括参考设计）、应用或其他设计建议、网络工具、安全信息和其他资源，不保证没有瑕疵且不做任何明示或暗示的担保，包括但不限于对适销性、某特定用途方面的适用性或不侵犯任何第三方知识产权的暗示担保。

这些资源可供使用 TI 产品进行设计的熟练开发人员使用。您将自行承担以下全部责任：(1) 针对您的应用选择合适的 TI 产品，(2) 设计、验证并测试您的应用，(3) 确保您的应用满足相应标准以及任何其他功能安全、信息安全、监管或其他要求。

这些资源如有变更，恕不另行通知。TI 授权您仅可将这些资源用于研发本资源所述的 TI 产品的应用。严禁对这些资源进行其他复制或展示。您无权使用任何其他 TI 知识产权或任何第三方知识产权。您应全额赔偿因在这些资源的使用中对 TI 及其代表造成的任何索赔、损害、成本、损失和债务，TI 对此概不负责。

TI 提供的产品受 [TI 的销售条款](#) 或 [ti.com](#) 上其他适用条款/TI 产品随附的其他适用条款的约束。TI 提供这些资源并不会扩展或以其他方式更改 TI 针对 TI 产品发布的适用的担保或担保免责声明。

TI 反对并拒绝您可能提出的任何其他或不同的条款。

邮寄地址：Texas Instruments, Post Office Box 655303, Dallas, Texas 75265
Copyright © 2024，德州仪器 (TI) 公司