

# UCC21710-Q1 适用于 SiC/IGBT 并具有主动保护、隔离式模拟感应和高 CMTI 的 10A 拉电流/灌电流增强型隔离式单通道栅极驱动器

## 1 特性

- 5.7kV<sub>RMS</sub> 单通道隔离式栅极驱动器
- 符合面向汽车应用的 AEC-Q100 标准
  - 器件温度等级 1：-40°C 至 +125°C 环境温度范围
- 高达 2121V<sub>pk</sub> 的 SiC MOSFET 和 IGBT
- 33V 最大输出驱动电压 (VDD-VEE)
- ±10A 驱动强度和分离输出
- 150V/ns 最小 CMTI
- 具有 270ns 快速响应时间的过流保护
- 4A 内部有源米勒钳位
- 发生故障时的 400mA 软关断
- 具有 PWM 输出的隔离式模拟传感器
  - 采用 NTC、PTC 或热敏二极管的温度感应
  - 高电压直流链路或相电压
- 过流警报 FLT 和通过 RST/EN 重置
- 针对 RST/EN 的快速启用/禁用响应
- 抑制输入引脚上的 <40ns 噪声瞬态和脉冲
- RDY 上的 12V VDD UVLO (具有电源正常指示功能)
- 具有高达 5V 的过冲/欠冲瞬态电压抗扰度的输入/输出
- 130ns (最大) 传播延迟和 30ns (最大) 脉冲/器件间偏移
- SOIC-16 DW 封装, 爬电距离和间隙 > 8mm
- 工作结温范围: -40°C 至 150°C
- 安全相关认证:
  - 符合 DIN EN IEC 60747-17 (VDE 0884-17) 标准的增强型绝缘
  - UL 1577 组件认证计划

输入侧通过 SiO<sub>2</sub> 电容隔离技术与输出侧相隔离, 支持高达 1.5kV<sub>RMS</sub> 的工作电压、12.8kV<sub>PK</sub> 的浪涌抗扰度, 隔离栅寿命超过 40 年, 并提供较低的器件间偏斜, 共模噪声抗扰度 (CMTI) 大于 150V/ns。

UCC21710-Q1 具有高级保护功能, 如快速过流和短路检测、分流电流检测支持、故障报告、有源米勒钳位以及输入和输出侧电源 UVLO (用于优化 SiC 和 IGBT 开关行为和稳健性)。可以使用隔离式模拟至 PWM 传感器更轻松检测温度或电压, 从而进一步提高驱动器的多功能性并消减系统设计工作量、尺寸和成本。

### 器件信息

器件型号	封装 <sup>(1)</sup>	封装尺寸 (标称值)
UCC21710-Q1	DW (SOIC-16)	10.3mm × 7.5mm

(1) 有关所有可用封装, 请参阅节 13。

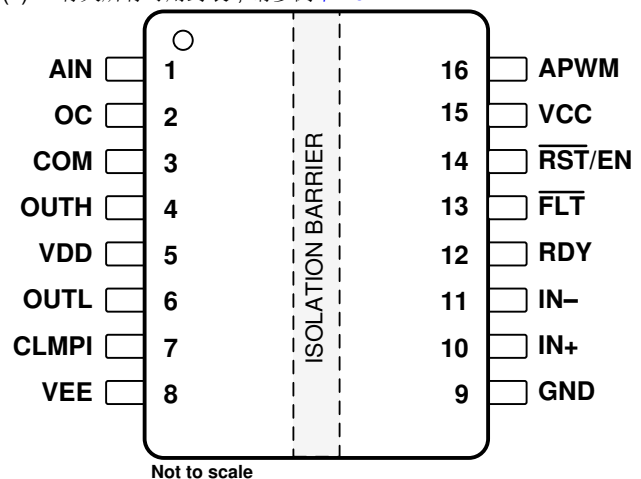

器件引脚配置

## 2 应用

- 适用于 EV 的牵引逆变器
- 车载充电器和充电桩
- 用于 HEV/EV 的直流/直流转换器

## 3 说明

UCC21710-Q1 是一款电隔离单通道栅极驱动器, 设计用于高达 1700V 的 SiC MOSFET 和 IGBT, 具有先进的保护功能、出色的动态性能和稳健性。UCC21710-Q1 具有高达 ±10A 的峰值拉电流和灌电流。



## Table of Contents

<b>1 特性</b> .....	<b>1</b>	<b>7 Detailed Description</b> .....	<b>24</b>
<b>2 应用</b> .....	<b>1</b>	7.1 Overview.....	24
<b>3 说明</b> .....	<b>1</b>	7.2 Functional Block Diagram.....	25
<b>4 Pin Configuration and Functions</b> .....	<b>3</b>	7.3 Feature Description.....	25
<b>5 Specifications</b> .....	<b>5</b>	7.4 Device Functional Modes.....	32
5.1 Absolute Maximum Ratings.....	5	<b>8 Applications and Implementation</b> .....	<b>33</b>
5.2 ESD Ratings.....	5	8.1 Application Information.....	33
5.3 Recommended Operating Conditions.....	5	8.2 Typical Application.....	34
5.4 Thermal Information.....	6	<b>9 Power Supply Recommendations</b> .....	<b>48</b>
5.5 Power Ratings.....	6	<b>10 Layout</b> .....	<b>49</b>
5.6 Insulation Specifications.....	7	10.1 Layout Guidelines.....	49
5.7 Safety-Related Certifications.....	8	10.2 Layout Example.....	50
5.8 Safety Limiting Values.....	8	<b>11 Device and Documentation Support</b> .....	<b>51</b>
5.9 Electrical Characteristics.....	9	11.1 Device Support.....	51
5.10 Switching Characteristics.....	12	11.2 Documentation Support.....	51
5.11 Insulation Characteristics Curves.....	13	11.3 接收文档更新通知.....	51
5.12 Typical Characteristics.....	14	11.4 支持资源.....	51
<b>6 Parameter Measurement Information</b> .....	<b>18</b>	11.5 Trademarks.....	51
6.1 Propagation Delay.....	18	11.6 静电放电警告.....	51
6.2 Input Deglitch Filter.....	19	11.7 术语表.....	51
6.3 Active Miller Clamp.....	20	<b>12 Revision History</b> .....	<b>52</b>
6.4 Under Voltage Lockout (UVLO).....	21	<b>13 Mechanical, Packaging, and Orderable Information</b> .....	<b>52</b>
6.5 OC (Over Current) Protection.....	23		

## 4 Pin Configuration and Functions



图 4-1. UCC21710-Q1 DW SOIC (16) Top View

表 4-1. Pin Functions

PIN		I/O <sup>(1)</sup>	DESCRIPTION
NAME	NO.		
AIN	1	I	Isolated analog sensing input, parallel a small capacitor to COM for better noise immunity. Tie to COM if unused.
OC	2	I	Over current detection pin, support lower threshold for SenseFET, DESAT, and shunt resistor sensing. Tie to COM if unused.
COM	3	P	Common ground reference, connecting to emitter pin for IGBT and source pin for SiC-MOSFET
OUTH	4	O	Gate driver output pull up
VDD	5	P	Positive supply rail for gate drive voltage. Bypass with a >10- $\mu$ F capacitor to COM to support specified gate driver source peak current capability. Place decoupling capacitor close to the pin.
OUTL	6	O	Gate driver output pull down
CLMPI	7	I	Internal Active miller clamp, connecting this pin directly to the gate of the power transistor. Leave floating or tie to VEE if unused.
VEE	8	P	Negative supply rail for gate drive voltage. Bypass with a >10- $\mu$ F capacitor to COM to support specified gate driver sink peak current capability. Place decoupling capacitor close to the pin.
GND	9	P	Input power supply and logic ground reference
IN+	10	I	Non-inverting gate driver control input. Tie to VCC if unused.
IN-	11	I	Inverting gate driver control input. Tie to GND if unused.
RDY	12	O	Power good for VCC-GND and VDD-COM. RDY is open drain configuration and can be paralleled with other RDY signals
FLT	13	O	Active low fault alarm output upon over current or short circuit. FLT is in open drain configuration and can be paralleled with other faults
RST/EN	14	I	The RST/EN serves two purposes: 1) Enable / shutdown of the output side. The FET is turned off by a regular turn-off, if terminal EN is set to low; 2) Resets the DESAT condition signaled on FLT pin. if terminal RST/EN is set to low for more than 1000ns. A reset of signal FLT is asserted at the rising edge of terminal RST/EN. For automatic RESET function, this pin only serves as an EN pin. Enable / shutdown of the output side. The FET is turned off by a general turn-off, if terminal EN is set to low.
VCC	15	P	Input power supply from 3V to 5.5V. Bypass with a >1- $\mu$ F capacitor to GND. Place decoupling capacitor close to the pin.

表 4-1. Pin Functions (续)

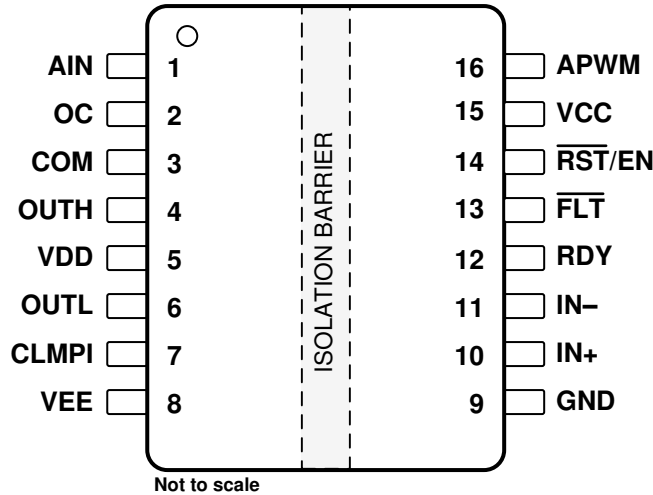
PIN		I/O <sup>(1)</sup>	DESCRIPTION
NAME	NO.		
APWM	16	O	Isolated Analog Sensing PWM output. Leave floating if unused.

(1) P = Power, G = Ground, I = Input, O = Output

## 5 Specifications

### 5.1 Absolute Maximum Ratings

over operating free-air temperature range (unless otherwise noted)<sup>(1)</sup>

PARAMETER		MIN	MAX	UNIT	
VCC	VCC - GND	- 0.3	6	V	
VDD	VDD - COM	- 0.3	36	V	
VEE	VEE - COM	- 17.5	0.3	V	
V <sub>MAX</sub>	VDD - VEE	- 0.3	36	V	
IN+, IN -, $\overline{\text{RST}}/\text{EN}$		DC	GND - 0.3	VCC	V
		Transient, less than 100 ns <sup>(2)</sup>	GND - 5.0	VCC+5.0	V
AIN	Reference to COM	- 0.3	5	V	
OC	Reference to COM	-0.3	6		
OUTH, OUTL, CLMPI		DC	VEE - 0.3	VDD	V
		Transient, less than 100 ns <sup>(2)</sup>	VEE - 5.0	VDD+5.0	V
RDY, $\overline{\text{FLT}}$ , APWM		GND - 0.3	VCC	V	
I <sub>FLT</sub> , I <sub>RDY</sub>	FLT, and RDY pin input current		20	mA	
I <sub>APWM</sub>	APWM pin output current		20	mA	
T <sub>J</sub>	Junction temperature range	- 40	150	°C	
T <sub>stg</sub>	Storage temperature range	- 65	150	°C	

- (1) Operation outside the Absolute Maximum Ratings may cause permanent device damage. Absolute Maximum Ratings do not imply functional operation of the device at these or any other conditions beyond those listed under Recommended Operating Conditions. If outside the Recommended Operating Conditions but within the Absolute Maximum Ratings, the device may not be fully functional, and this may affect device reliability, functionality, performance, and shorten the device lifetime.
- (2) Values are verified by characterization on bench.

### 5.2 ESD Ratings

		VALUE	UNIT
V <sub>(ESD)</sub>	Electrostatic discharge	Human-body model (HBM), per AEC Q100-002 <sup>(1)</sup>	±4000
		Charged-device model (CDM), per AEC Q100-011	±1500

- (1) AEC Q100-002 indicates that HBM stressing shall be in accordance with the ANSI/ESDA/JEDEC JS-001 specification.

### 5.3 Recommended Operating Conditions

PARAMETER		MIN	MAX	UNIT
VCC	VCC - GND	3.0	5.5	V
VDD	VDD - COM	13	33	V
V <sub>MAX</sub>	VDD - VEE	-	33	V
IN+, IN -, $\overline{\text{RST}}/\text{EN}$	Reference to GND	High level input voltage	0.7×VCC	VCC
		Low level input voltage	0	0.3×VCC
AIN	Reference to COM	0.6	4.5	V
t <sub>RST/EN</sub>	Minimum pulse width that reset the fault	1000		ns
T <sub>A</sub>	Ambient Temperature	- 40	125	°C
T <sub>J</sub>	Junction temperature	- 40	150	°C

## 5.4 Thermal Information

THERMAL METRIC <sup>(1)</sup>		UCC21710 -Q1	
		DW (SOIC)	
		16-PINS	
			UNIT
$R_{\theta JA}$	Junction-to-ambient thermal resistance	68.3	°C/W
$R_{\theta JC(top)}$	Junction-to-case (top) thermal resistance	27.5	°C/W
$R_{\theta JB}$	Junction-to-board thermal resistance	32.9	°C/W
$\psi_{JT}$	Junction-to-top characterization parameter	14.1	°C/W
$\psi_{JB}$	Junction-to-board characterization parameter	32.3	°C/W

(1) For more information about traditional and new thermal metrics, see the [Semiconductor and IC Package Thermal Metrics](#) application report.

## 5.5 Power Ratings

PARAMETER		TEST CONDITIONS	Value	UNIT
$P_D$	Maximum power dissipation (both sides)		985	mW
$P_{D1}$	Maximum power dissipation by transmitter side	VCC = 5V, VDD-COM = 20V, COM-VEE = 5V, IN+/- = 5V, 150kHz, 50% Duty Cycle for 10nF load, $T_a=25^\circ\text{C}$	20	mW
$P_{D2}$	Maximum power dissipation by receiver side		965	mW

## 5.6 Insulation Specifications

PARAMETER		TEST CONDITIONS	VALUE	UNIT
<b>GENERAL</b>				
CLR	External clearance <sup>(1)</sup>	Shortest terminal-to-terminal distance through air	> 8	mm
CPG	External creepage <sup>(1)</sup>	Shortest terminal-to-terminal distance across the package surface	> 8	mm
DTI	Distance through the insulation	Minimum internal gap (Internal clearance) of the double insulation (2 × 0.0085 mm)	> 17	µm
CTI	Comparative tracking index	DIN EN 60112 (VDE 0303-11); IEC 60112	> 600	V
	Material group	According to IEC 60664 - 1	I	
	Overvoltage Category per IEC 60664 - 1	Rated mains voltage ≤ 300 V <sub>RMS</sub>	I-IV	
		Rated mains voltage ≤ 600 V <sub>RMS</sub>	I-IV	
		Rated mains voltage ≤ 1000 V <sub>RMS</sub>	I-III	
<b>DIN EN IEC 60747-17 (VDE 0884-17)<sup>(2)</sup></b>				
V <sub>IORM</sub>	Maximum repetitive peak isolation voltage	AC voltage (bipolar)	2121	V <sub>PK</sub>
V <sub>IOWM</sub>	Maximum isolation working voltage	AC voltage (sine wave) Time dependent dielectric breakdown (TDDb) test	1500	V <sub>RMS</sub>
		DC voltage	2121	V <sub>DC</sub>
V <sub>IMP</sub>	Maximum impulse voltage	Tested in air, 1.2/50- µ s waveform per IEC 62368-1	8000	V <sub>PK</sub>
V <sub>IOTM</sub>	Maximum transient isolation voltage	V <sub>TEST</sub> =V <sub>IOTM</sub> , t = 60 s (qualification test)	8000	V <sub>PK</sub>
		V <sub>TEST</sub> =1.2 × V <sub>IOTM</sub> , t = 1 s (100% production test)		
V <sub>IOSM</sub>	Maximum surge isolation voltage <sup>(3)</sup>	Test method per IEC 62368-1, 1.2/50 µs waveform, V <sub>TEST</sub> = 1.6 × V <sub>IOSM</sub> = 12800 V <sub>PK</sub> (qualification)	8000	V <sub>PK</sub>
q <sub>pd</sub>	Apparent charge <sup>(4)</sup>	Method a: After I/O safety test subgroup 2/3, V <sub>ini</sub> = V <sub>IOTM</sub> , t <sub>ini</sub> = 60 s; V <sub>pd(m)</sub> = 1.2 × V <sub>IORM</sub> = 2545 V <sub>PK</sub> , t <sub>m</sub> = 10 s	≤ 5	pC
		Method a: After environmental tests subgroup 1, V <sub>ini</sub> = V <sub>IOTM</sub> , t <sub>ini</sub> = 60 s; V <sub>pd(m)</sub> = 1.6 × V <sub>IORM</sub> = 3394 V <sub>PK</sub> , t <sub>m</sub> = 10 s	≤ 5	
		Method b1: At routine test (100% production) and preconditioning (type test) V <sub>ini</sub> = V <sub>IOTM</sub> , t <sub>ini</sub> = 1 s; V <sub>pd(m)</sub> = 1.875 × V <sub>IORM</sub> = 3977 V <sub>PK</sub> , t <sub>m</sub> = 1 s	≤ 5	
C <sub>IO</sub>	Barrier capacitance, input to output <sup>(5)</sup>	V <sub>IO</sub> = 0.5 sin (2 π ft), f = 1 MHz	~ 1	pF
R <sub>IO</sub>	Insulation resistance, input to output <sup>(5)</sup>	V <sub>IO</sub> = 500 V, T <sub>A</sub> = 25°C	≥ 10 <sup>12</sup>	Ω
		V <sub>IO</sub> = 500 V, 100°C ≤ T <sub>A</sub> ≤ 125°C	≥ 10 <sup>11</sup>	
		V <sub>IO</sub> = 500 V at T <sub>S</sub> = 150°C	≥ 10 <sup>9</sup>	
	Pollution degree		2	
	Climatic category		40/125/21	
<b>UL 1577</b>				
V <sub>ISO</sub>	Withstand isolation voltage	V <sub>TEST</sub> = V <sub>ISO</sub> = 5700 V <sub>RMS</sub> , t = 60 s (qualification); V <sub>TEST</sub> = 1.2 × V <sub>ISO</sub> = 6840 V <sub>RMS</sub> , t = 1 s (100% production)	5700	V <sub>RMS</sub>

- (1) Apply creepage and clearance requirements according to the specific equipment isolation standards of an application. Care must be taken to maintain the creepage and clearance distance of a board design to ensure that the mounting pads of the isolator on the printed circuit board (PCB) do not reduce this distance. Creepage and clearance on a PCB become equal in certain cases. Techniques such as inserting grooves and ribs on the PCB are used to help increase these specifications.
- (2) This coupler is suitable for safe electrical insulation only within the safety ratings. Compliance with the safety ratings shall be ensured by means of suitable protective circuits.
- (3) Testing is carried out in air or oil to determine the intrinsic surge immunity of the isolation barrier.
- (4) Apparent charge is electrical discharge caused by a partial discharge (pd).
- (5) All pins on each side of the barrier tied together creating a two-terminal device

## 5.7 Safety-Related Certifications

VDE	UL
Certified according to DIN EN IEC 60747-17 (VDE 0884-17)	Recognized under UL 1577 Component Recognition Program, CSA Component Acceptance Notice 5A
Reinforced insulation Maximum transient isolation voltage, 8000 V <sub>PK</sub> ; Maximum repetitive peak isolation voltage, 2121 V <sub>PK</sub> ; Maximum surge isolation voltage, 8000 V <sub>PK</sub>	Single protection, 5700 V <sub>RMS</sub>
Certificate number: 40040142	File Number: E181974

## 5.8 Safety Limiting Values

The safety-limiting constraint is the maximum junction temperature specified in the data sheet. The power dissipation and junction-to-air thermal impedance of the device installed in the application hardware determines the junction temperature. The assumed junction-to-air thermal resistance in the [Thermal Information](#) table is that of a device installed on a high-K test board for leaded surface-mount packages. The power is the recommended maximum input voltage times the current. The junction temperature is then the ambient temperature plus the power times the junction-to-air thermal resistance. These limits vary with the ambient temperature, the junction-to-air thermal resistance, and the power supply voltages in different applications.

PARAMETER	TEST CONDITIONS	MIN	TYP	MAX	UNIT
I <sub>S</sub> Safety input, output, or supply current	R <sub>θJA</sub> = 68.3°C/W, V <sub>DD</sub> = 15V, V <sub>EE</sub> = -5V, T <sub>J</sub> = 150°C, T <sub>A</sub> = 25°C			61	mA
	R <sub>θJA</sub> = 68.3°C/W, V <sub>DD</sub> = 20V, V <sub>EE</sub> = -5V, T <sub>J</sub> = 150°C, T <sub>A</sub> = 25°C			49	
P <sub>S</sub> Safety input, output, or total power	R <sub>θJA</sub> = 68.3°C/W, V <sub>DD</sub> = 20V, V <sub>EE</sub> = -5V, T <sub>J</sub> = 150°C, T <sub>A</sub> = 25°C			1220	mW
T <sub>S</sub> Safety temperature				150	°C



## 5.9 Electrical Characteristics

VCC=3.3V or 5.0V, 1uF capacitor from VCC to GND, VDD - COM=20V, 18V or 15V, COM - VEE =0V, 5V, 8V or 15V, C<sub>L</sub>=100pF, - 40°C<T<sub>J</sub><150°C (unless otherwise noted)<sup>(1) (2)</sup>.

PARAMETER		TEST CONDITIONS	MIN	TYP	MAX	UNIT
<b>VCC UVLO THRESHOLD AND DELAY</b>						
V <sub>VCC_ON</sub>	VCC - GND		2.55	2.7	2.85	V
V <sub>VCC_OFF</sub>			2.35	2.5	2.65	
V <sub>VCC_HYS</sub>				0.2		
t <sub>VCCFIL</sub>	VCC UVLO Deglitch time			10		μs
t <sub>VCC+ to OUT</sub>	VCC UVLO on delay to output high	IN+ = VCC, IN - = GND	28	37.8	50	
t <sub>VCC- to OUT</sub>	VCC UVLO off delay to output low		5	10	15	
t <sub>VCC+ to RDY</sub>	VCC UVLO on delay to RDY high	RST/EN = VCC	30	37.8	50	
t <sub>VCC- to RDY</sub>	VCC UVLO off delay to RDY low		5	10	15	
<b>VDD UVLO THRESHOLD AND DELAY</b>						
V <sub>VDD_ON</sub>	VDD - COM		10.5	12.0	12.8	V
V <sub>VDD_OFF</sub>			9.9	10.7	11.8	
V <sub>VDD_HYS</sub>				0.8		
t <sub>VDDFIL</sub>	VDD UVLO Deglitch time			5		μs
t <sub>VDD+ to OUT</sub>	VDD UVLO on delay to output high	IN+ = VCC, IN - = GND	2	5	8	
t <sub>VDD- to OUT</sub>	VDD UVLO off delay to output low		5	10	15	
t <sub>VDD+ to RDY</sub>	VDD UVLO on delay to RDY high	RST/EN = FLT=High		10	15	
t <sub>VDD- to RDY</sub>	VDD UVLO off delay to RDY low		10	15	15	
<b>VCC, VDD QUIESCENT CURRENT</b>						
I <sub>VCCQ</sub>	VCC quiescent current	OUT(H) = High, f <sub>S</sub> = 0Hz, AIN=2V	2.5	3	4	mA
		OUT(L) = Low, f <sub>S</sub> = 0Hz, AIN=2V	1.45	2	2.75	
I <sub>VDDQ</sub>	VDD quiescent current	OUT(H) = High, f <sub>S</sub> = 0Hz, AIN=2V	3.6	4	5.9	mA
		OUT(L) = Low, f <sub>S</sub> = 0Hz, AIN=2V	3.1	3.7	5.3	
<b>LOGIC INPUTS — IN+, IN - and RST/EN</b>						
V <sub>INH</sub>	Input high threshold	V <sub>CC</sub> =3.3V		1.85	2.31	V
V <sub>INL</sub>	Input low threshold	V <sub>CC</sub> =3.3V	0.99	1.52		V
V <sub>INHYS</sub>	Input threshold hysteresis	V <sub>CC</sub> =3.3V		0.33		V
I <sub>IH</sub>	Input high level input leakage current	V <sub>IN</sub> = VCC		90		μA
I <sub>IL</sub>	Input low level input leakage	V <sub>IN</sub> = GND		- 90		μA
R <sub>IND</sub>	Input pins pull down resistance	see <a href="#">Detailed Description</a> for more information	28.5	55	113	kΩ
R <sub>INU</sub>	Input pins pull up resistance	see <a href="#">Detailed Description</a> for more information	28.5	55	113	
T <sub>INFIL</sub>	IN+, IN - and RST/EN deglitch (ON and OFF) filter time	f <sub>S</sub> = 50kHz	28	40	60	ns
T <sub>RSTFIL</sub>	Deglitch filter time to reset /FLT		400	650	800	ns
<b>GATE DRIVER STAGE</b>						
I <sub>OUT</sub> , I <sub>OUTH</sub>	Peak source current	C <sub>L</sub> =0.18μF, f <sub>S</sub> =1kHz		10		A
I <sub>OUT</sub> , I <sub>OUTL</sub>	Peak sink current				10	
R <sub>OUTH</sub> <sup>(3)</sup>	Output pull-up resistance	I <sub>OUT</sub> = - 0.1A	1.5	2.5	4.9	Ω

## 5.9 Electrical Characteristics (续)

VCC=3.3V or 5.0V, 1uF capacitor from VCC to GND, VDD - COM=20V, 18V or 15V, COM - VEE =0V, 5V, 8V or 15V, C<sub>L</sub>=100pF, - 40°C<T<sub>J</sub><150°C (unless otherwise noted)<sup>(1)</sup> <sup>(2)</sup>.

PARAMETER		TEST CONDITIONS	MIN	TYP	MAX	UNIT
R <sub>OUTL</sub>	Output pull-down resistance	I <sub>OUT</sub> = 0.1A	0.1	0.3	0.7	Ω
V <sub>OUTH</sub>	High level output voltage	I <sub>OUT</sub> = - 0.2A, V <sub>DD</sub> =18V		17.5		V
V <sub>OUTL</sub>	Low level output voltage	I <sub>OUT</sub> = 0.2A		60		mV
<b>ACTIVE PULLDOWN</b>						
V <sub>OUTPD</sub>	Output active pull down on OUT, OUTL	I <sub>OUTL</sub> or I <sub>OUT</sub> = 0.1×I <sub>OUT(L)(typ)</sub> , V <sub>DD</sub> =OPEN, V <sub>EE</sub> =COM	1.5	2	2.5	V
<b>INTERNAL ACTIVE MILLER CLAMP</b>						
V <sub>CLMPH</sub>	Miller clamp threshold voltage	Reference to VEE	1.5	2.0	2.5	V
V <sub>CLMPI</sub>	Output low clamp voltage	I <sub>CLMPI</sub> = 1A		VEE + 0.5		V
I <sub>CLMPI</sub>	Output low clamp current	V <sub>CLMPI</sub> = 0V, VEE = - 2.5V		4		A
R <sub>CLMPI</sub>	Miller clamp pull down resistance	I <sub>CLMPI</sub> = 0.2A		0.6		Ω
t <sub>DCLMPI</sub>	Miller clamp ON delay time	C <sub>L</sub> = 1.8nF		15	50	ns
<b>SHORT CIRCUIT CLAMPING</b>						
V <sub>CLP-OUT(H)</sub>	V <sub>OUT</sub> - VDD, V <sub>OUTH</sub> - VDD	OUT = Low, I <sub>OUT(H)</sub> = 500mA, t <sub>CLP</sub> =10us		0.9		V
V <sub>CLP-OUT(L)</sub>	V <sub>OUT</sub> - VDD, V <sub>OUTL</sub> - VDD	OUT = High, I <sub>OUT(L)</sub> = 500mA, t <sub>CLP</sub> =10us		1.8		V
V <sub>CLP-CLMPI</sub>	V <sub>CLMPI</sub> - VDD	OUT = High, I <sub>CLMPI</sub> = 20mA, t <sub>CLP</sub> =10us		1.0		V
<b>OC PROTECTION</b>						
I <sub>DCHG</sub>	OC pull down current when	V <sub>OC</sub> = 1V		40		mA
V <sub>OCTH</sub>	Detection Threshold		0.63	0.7	0.77	V
V <sub>OCL</sub>	Voltage when OUT(L) = LOW, Reference to COM	I <sub>OC</sub> = 5mA		0.13		V
t <sub>OCFIL</sub>	OC fault deglitch filter		95	120	180	ns
t <sub>OCOFF</sub>	OC propagation delay to OUT(L) 90%		150	270	400	ns
t <sub>OCFLT</sub>	OC to FLT low delay		300	530	750	ns
<b>INTERNAL SOFT TURN-OFF</b>						
I <sub>STO</sub>	Soft turn-off current on fault conditions	V <sub>DD</sub> -V <sub>EE</sub> =20V, V <sub>OUTL</sub> -COM=8V	250	400	570	mA
<b>ISOLATED TEMPERATURE SENSE AND MONITOR (AIN - APWM)</b>						
V <sub>AIN</sub>	Analog sensing voltage range		0.6		4.5	V
I <sub>AIN</sub>	Internal current source	V <sub>AIN</sub> =2.5V, -40°C< T <sub>J</sub> < 150°C	196	200	209	μA
f <sub>APWM</sub>	APWM output frequency	V <sub>AIN</sub> =2.5V	380	400	420	kHz
BW <sub>AIN</sub>	AIN - APWM bandwidth			10		kHz
D <sub>APWM</sub>	APWM Dutycycle	V <sub>AIN</sub> = 0.6V	86.5	88	89.5	%
		V <sub>AIN</sub> = 2.5V	48.5	50	51.5	
		V <sub>AIN</sub> = 4.5V	7.5	10	11.5	
<b>FLT AND RDY REPORTING</b>						
t <sub>RDYHLD</sub>	VDD UVLO RDY low minimum holding time		0.55		1	ms
t <sub>FLTMUTE</sub>	Output mute time on fault	Reset fault through RST/EN	0.55		1	ms
R <sub>ODON</sub>	Open drain output on resistance	I <sub>ODON</sub> = 5mA		30		Ω
V <sub>ODL</sub>	Open drain low output voltage	I <sub>ODON</sub> = 5mA			0.3	V
<b>COMMON MODE TRANSIENT IMMUNITY</b>						
CMTI	Common-mode transient immunity		150			V/ns

(1) Current are positive into and negative out of the specified terminal.

(2) All voltages are referenced to COM unless otherwise notified.

- (3) For internal PMOS only. Refer to [Feature Description](#) for effective pull-up resistance.

## 5.10 Switching Characteristics

VCC=5.0V, 1uF capacitor from VCC to GND, VDD – COM=20V, 18V or 15V, COM – VEE = 3V, 5V or 8V, C<sub>L</sub>=100pF, – 40°C<T<sub>J</sub><150°C (unless otherwise noted)

PARAMETER		TEST CONDITIONS	MIN	TYP	MAX	UNIT
t <sub>PDHL</sub>	Propagation delay time – High to Low		60	90	130	ns
t <sub>PDLH</sub>	Propagation delay time – Low to High		60	90	130	
PWD	Pulse width distortion   t <sub>PDHL</sub> – t <sub>PDLH</sub>				30	
t <sub>sk-pp</sub>	Part to Part skew	Rising or Falling Propagation Delay			30	
t <sub>r</sub>	Driver output rise time	C <sub>L</sub> =10nF		33		
t <sub>f</sub>	Driver output fall time	C <sub>L</sub> =10nF		27		
f <sub>MAX</sub>	Maximum switching frequency				1	MHz

### 5.11 Insulation Characteristics Curves



图 5-1. Thermal Derating Curve for Limiting Current per VDE



图 5-2. Thermal Derating Curve for Limiting Power per VDE

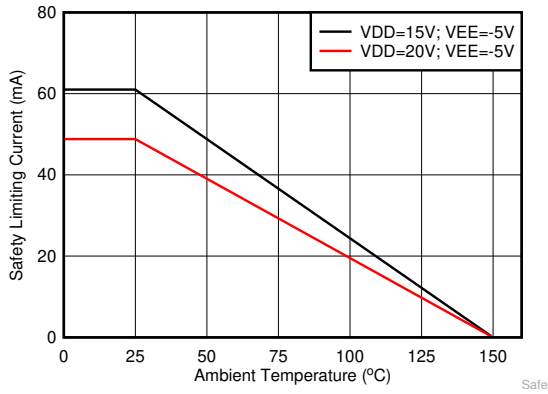

图 5-3. Reinforced Isolation Capacitor Life Time Projection

### 5.12 Typical Characteristics

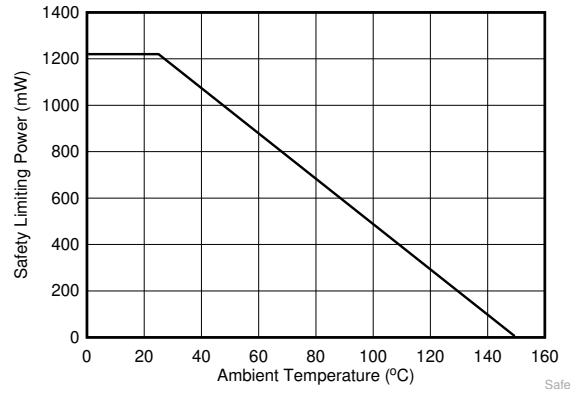

图 5-4. Output High Drive Current vs. Temperature

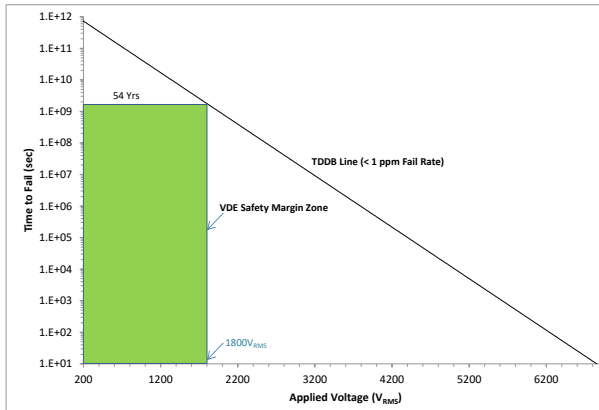

图 5-5. Output Low Driver Current vs. Temperature

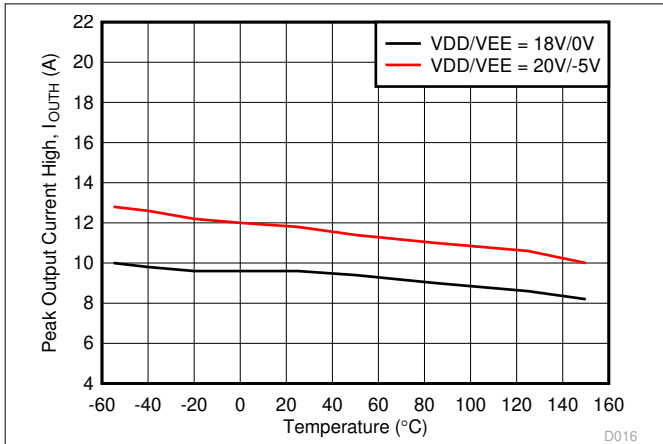

图 5-6. I<sub>VCCQ</sub> Supply Current vs. Temperature

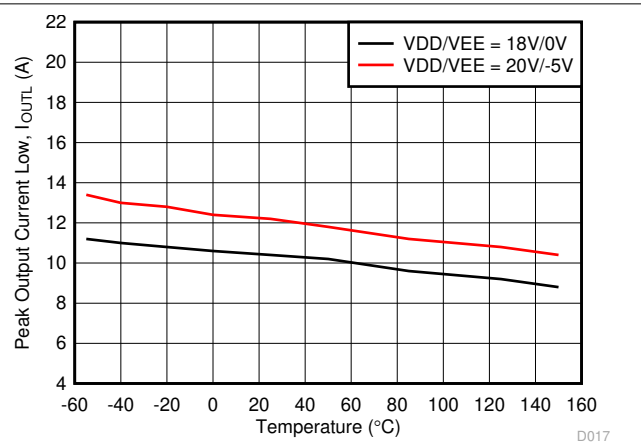

图 5-7. I<sub>VCCQ</sub> Supply Current vs. Temperature

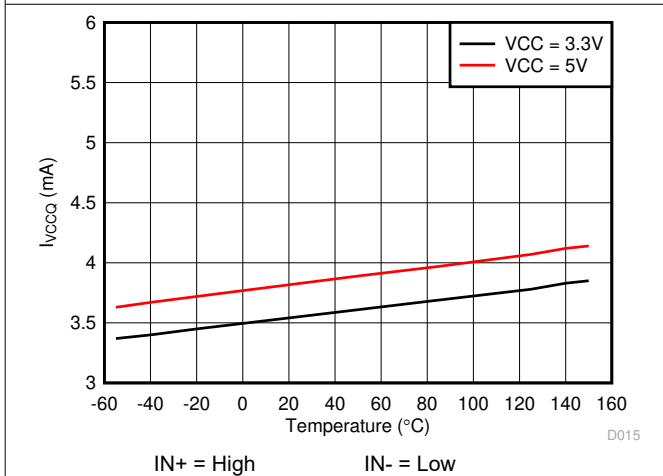

图 5-8. I<sub>VCCQ</sub> Supply Current vs. Input Frequency

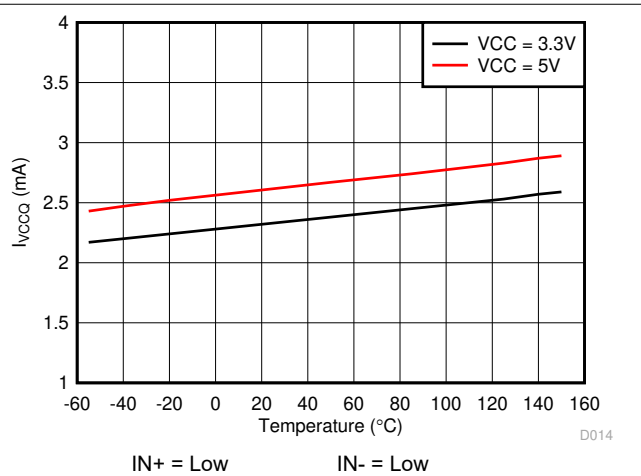

图 5-9. I<sub>VDDQ</sub> Supply Current vs. Temperature

### 5.12 Typical Characteristics (continued)

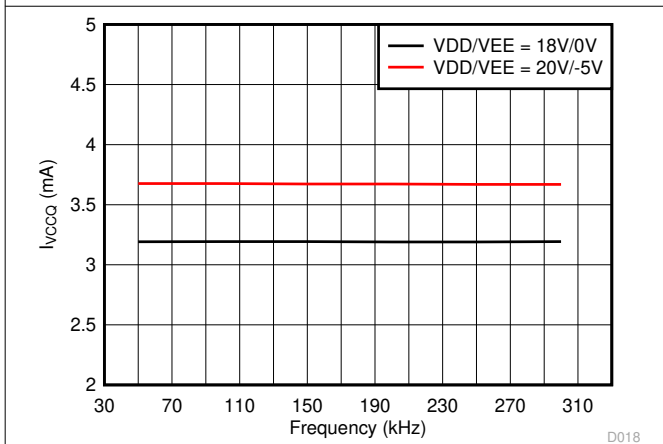

### 5.12 Typical Characteristics (continued)

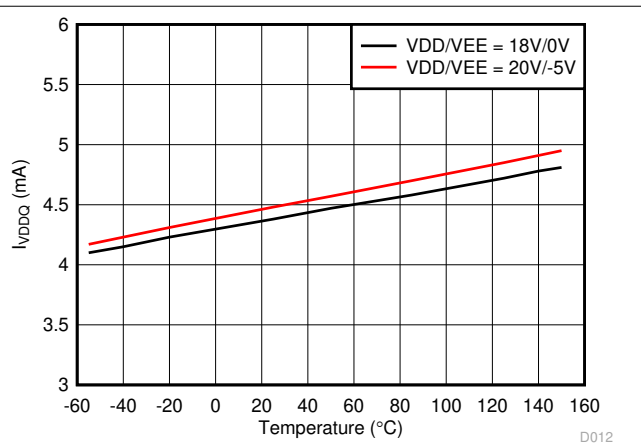
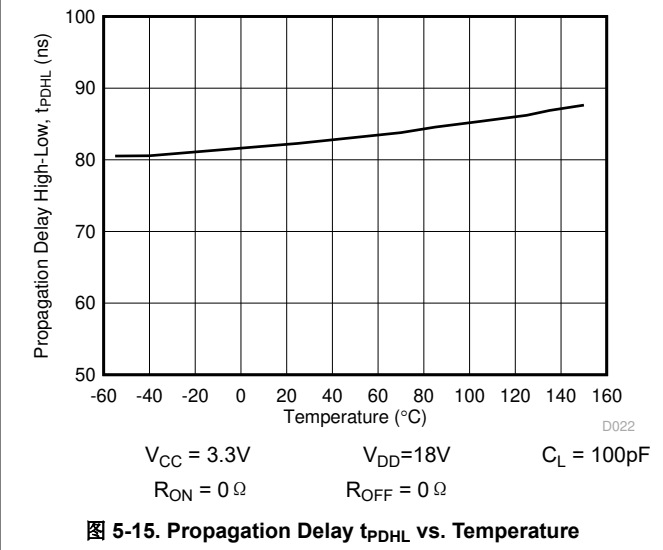
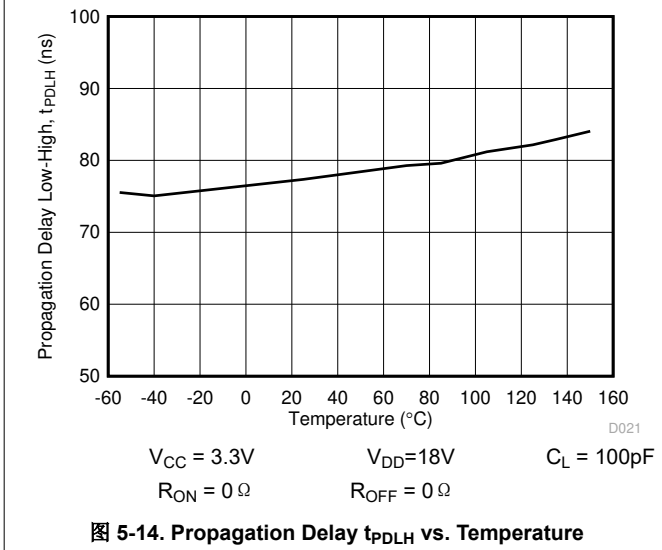
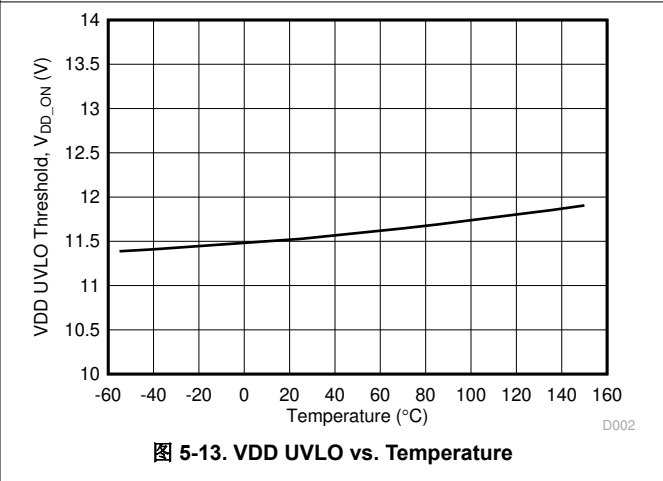
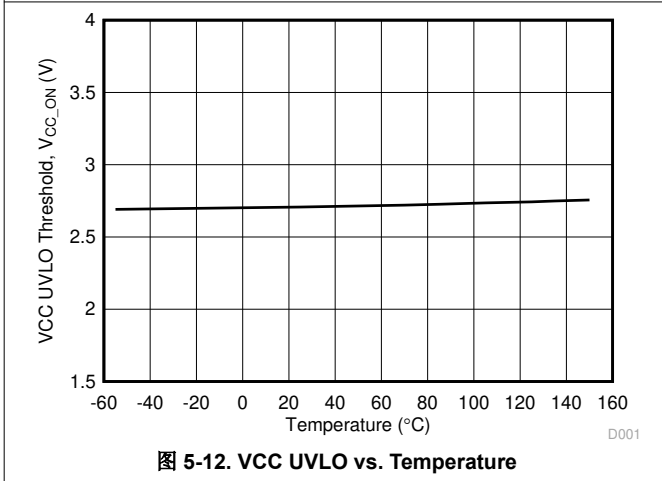
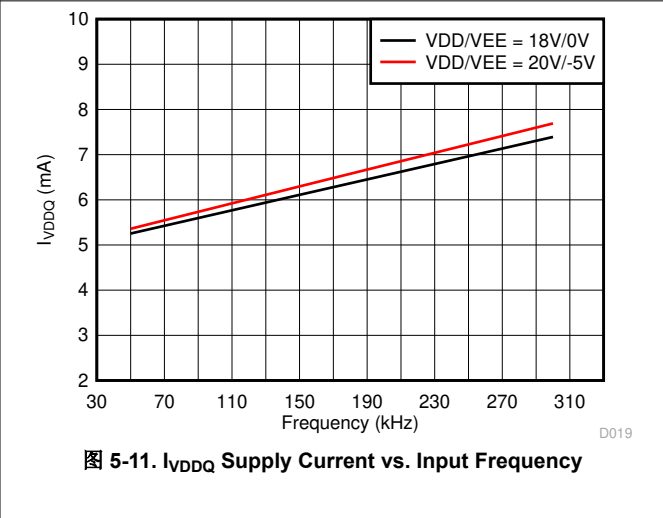
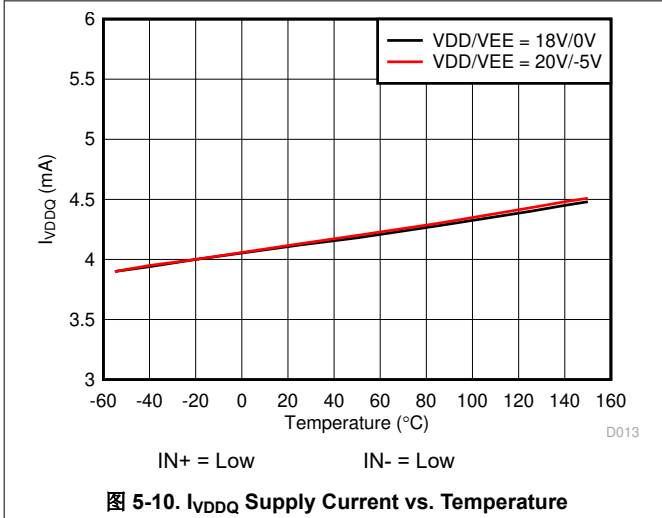
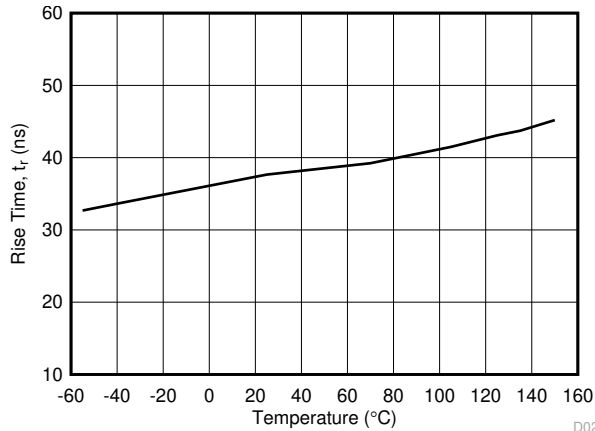

$V_{CC} = 3.3V$        $V_{DD} = 18V$        $C_L = 10nF$   
 $R_{ON} = 0\Omega$        $R_{OFF} = 0\Omega$

图 5-16.  $t_r$  Rise Time vs. Temperature

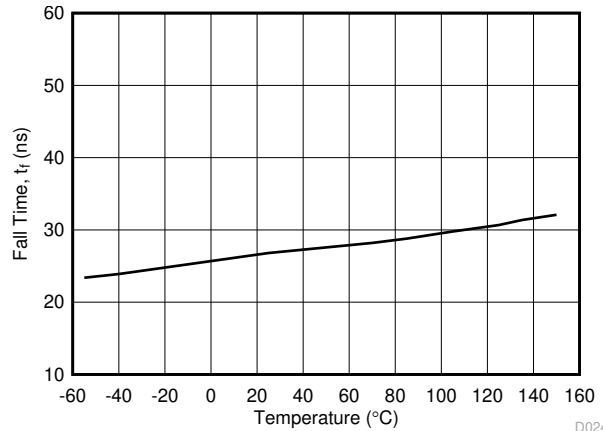

$V_{CC} = 3.3V$        $V_{DD} = 18V$        $C_L = 10nF$   
 $R_{ON} = 0\Omega$        $R_{OFF} = 0\Omega$

图 5-17.  $t_f$  Fall Time vs. Temperature



图 5-18.  $V_{OUTPD}$  Output Active Pulldown Voltage vs. Temperature



图 5-19.  $V_{CLP-OUT(H)}$  Short Circuit Clamping Voltage vs. Temperature

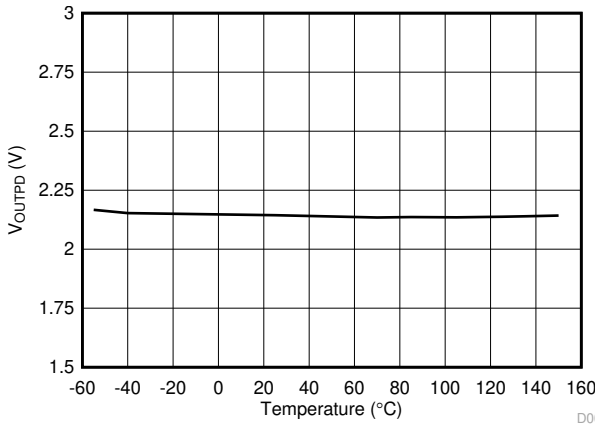

图 5-20.  $V_{CLP-OUT(L)}$  Short Circuit Clamping Voltage vs. Temperature

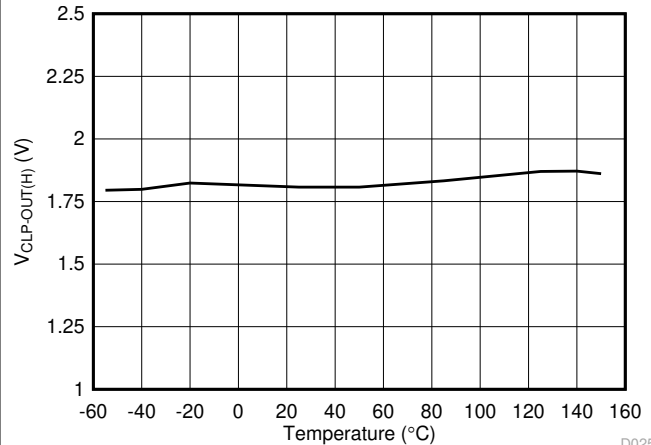

图 5-21.  $V_{CLMPH}$  Miller Clamp Threshold Voltage vs. Temperature

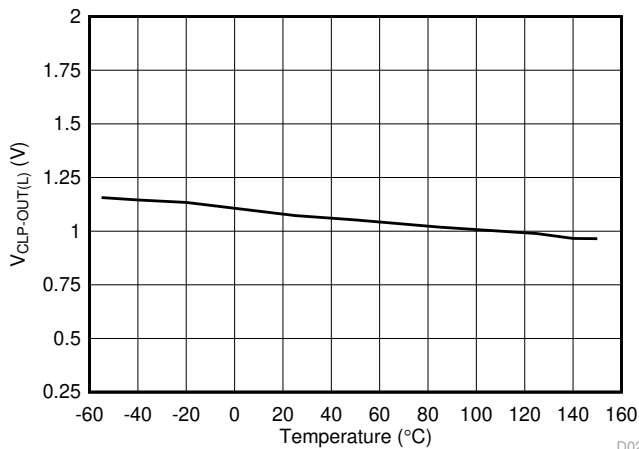

### 5.12 Typical Characteristics (continued)

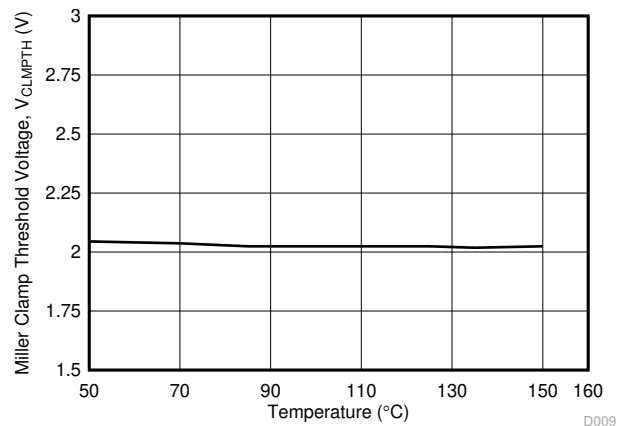

图 5-22.  $I_{CLMPI}$  Miller Clamp Sink Current vs. Temperature



图 5-23.  $t_{DCLMPI}$  Miller Clamp ON Delay Time vs. Temperature

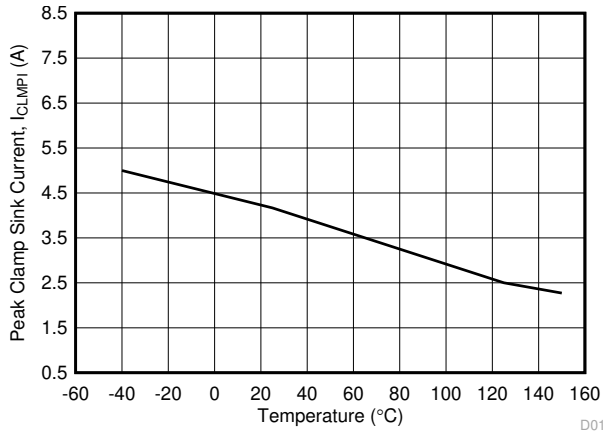

图 5-24.  $t_{OCOFF}$  OC Propagation Delay vs. Temperature

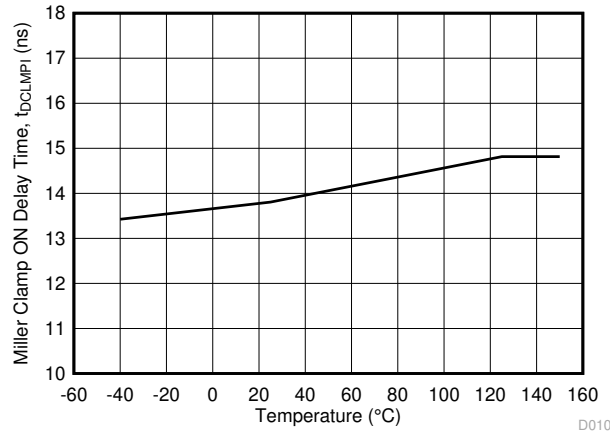

图 5-25.  $V_{OCTH}$  OC Detection Threshold vs. Temperature

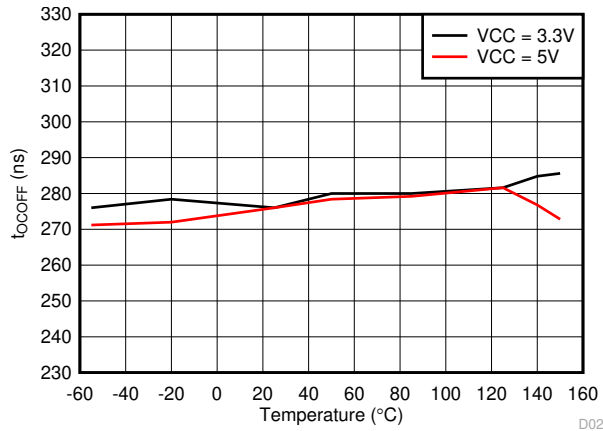

图 5-26.  $t_{OFLT}$  OC to  $\overline{FLT}$  Low Delay Time vs. Temperature

## 6 Parameter Measurement Information

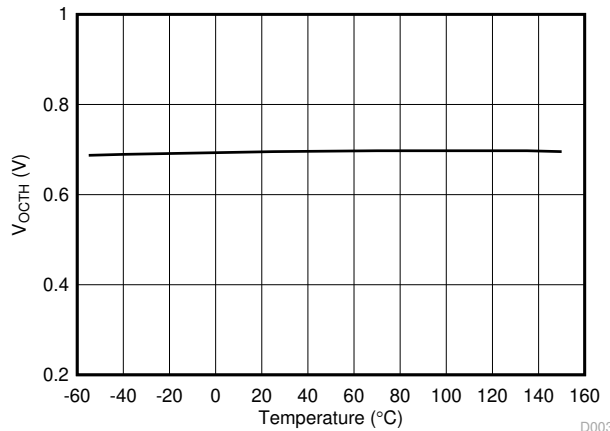
### 6.1 Propagation Delay

#### 6.1.1 Regular Turn-OFF

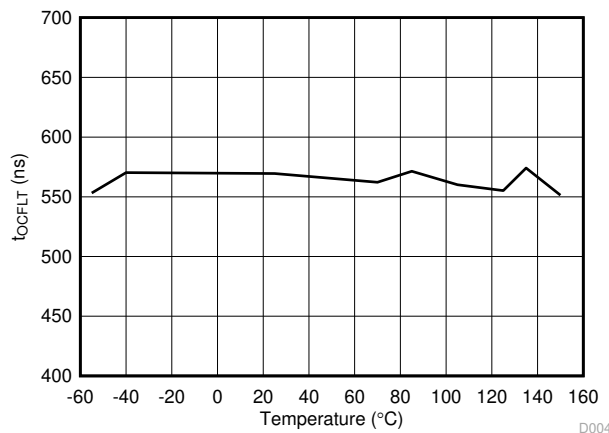
Figure 7-1 shows the propagation delay measurement for non-inverting configurations. Figure 7-2 shows the propagation delay measurement with the inverting configurations.



图 6-1. Non-inverting Logic Propagation Delay Measurement



图 6-2. Inverting Logic Propagation Delay Measurement

## 6.2 Input Deglitch Filter

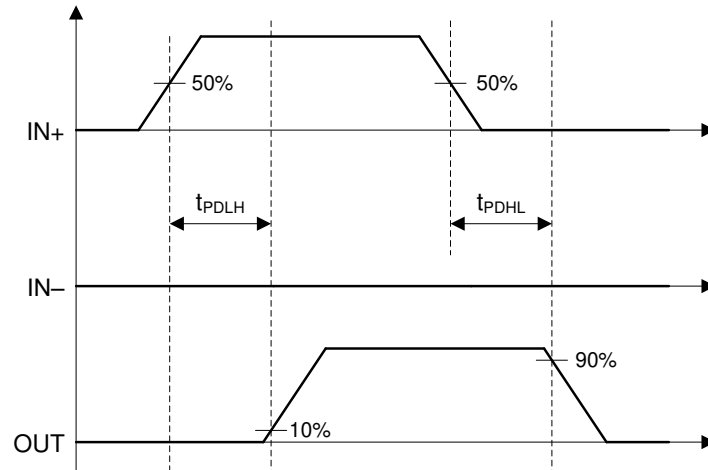
In order to increase the robustness of gate driver over noise transient and accidental small pulses on the input pins, i.e. IN+, IN-,  $\overline{\text{RST/EN}}$ , a 40ns deglitch filter is designed to filter out the transients and make sure there is no faulty output responses or accidental driver malfunctions. When the IN+ or IN- PWM pulse is smaller than the input deglitch filter width,  $T_{\text{INFIL}}$ , there will be no responses on OUT drive signal. Figure 6-3 and Figure 6-4 shows the IN+ pin ON and OFF pulse deglitch filter effect. Figure 6-5 and Figure 6-6 shows the IN- pin ON and OFF pulse deglitch filter effect.

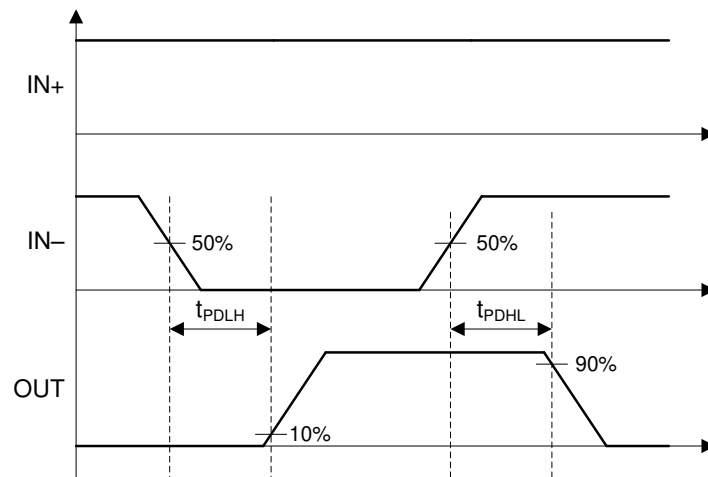

图 6-3. IN+ ON Deglitch Filter



图 6-4. IN+ OFF Deglitch Filter

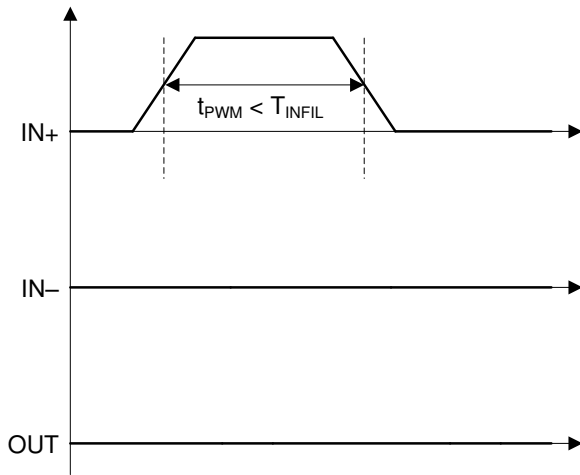

图 6-5. IN- ON Deglitch Filter

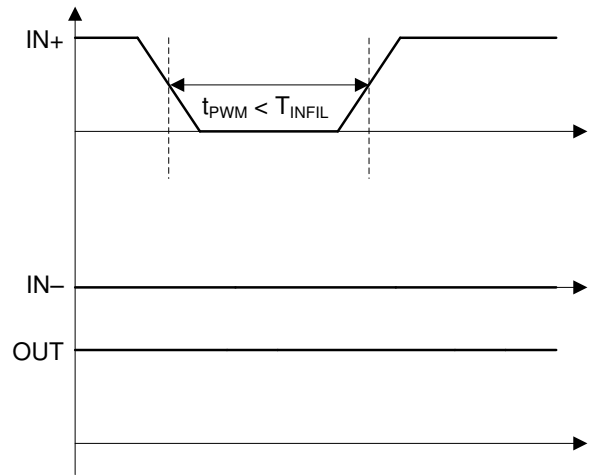

图 6-6. IN- OFF Deglitch Filter

## 6.3 Active Miller Clamp

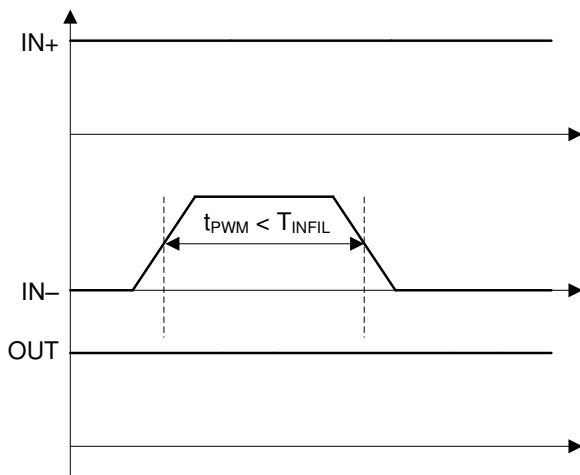
### 6.3.1 Internal On-chip Active Miller Clamp

For gate driver application with unipolar bias supply or bipolar supply with small negative turn-off voltage, active miller clamp can help add a additional low impedance path to bypass the miller current and prevent the high dV/dt introduced unintentional turn-on through the miller capacitance. [Figure 7-7](#) shows the timing diagram for on-chip internal miller clamp function.

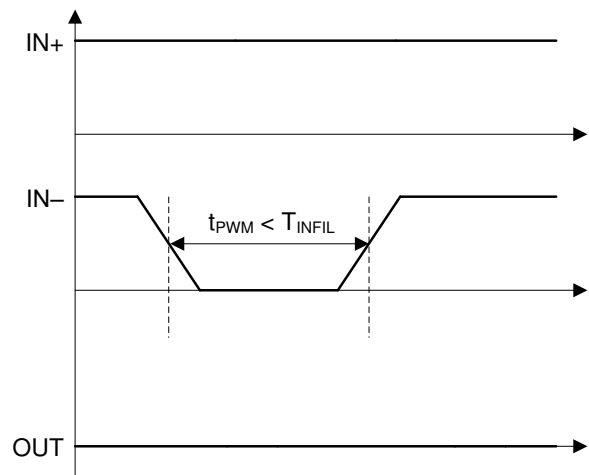

图 6-7. Timing Diagram for Internal Active Miller Clamp Function

## 6.4 Under Voltage Lockout (UVLO)

UVLO is one of the key protection features designed to protect the system in case of bias supply failures on VCC — primary side power supply, and VDD — secondary side power supply.

### 6.4.1 VCC UVLO

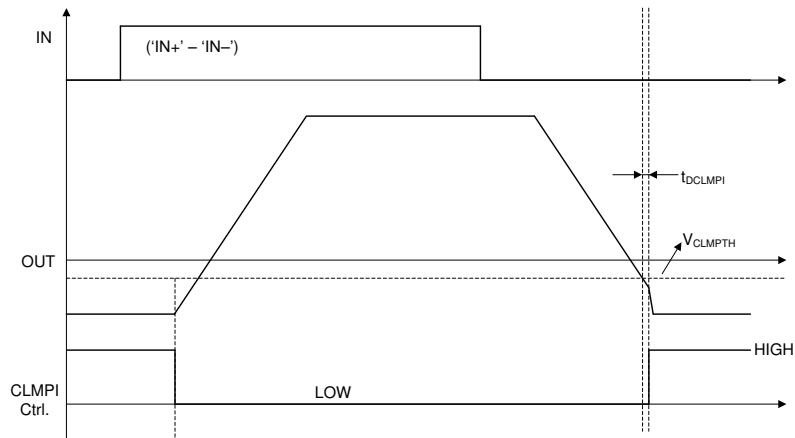
The VCC UVLO protection details are discussed in this section. Figure 7-8 shows the timing diagram illustrating the definition of UVLO ON/OFF threshold, deglitch filter, response time, RDY and AIN - APWM.



图 6-8. VCC UVLO Protection Timing Diagram

### 6.4.2 VDD UVLO

The VDD UVLO protection details are discussed in this section. Figure 7-9 shows the timing diagram illustrating the definition of UVLO ON/OFF threshold, deglitch filter, response time, RDY and AIN - APWM.

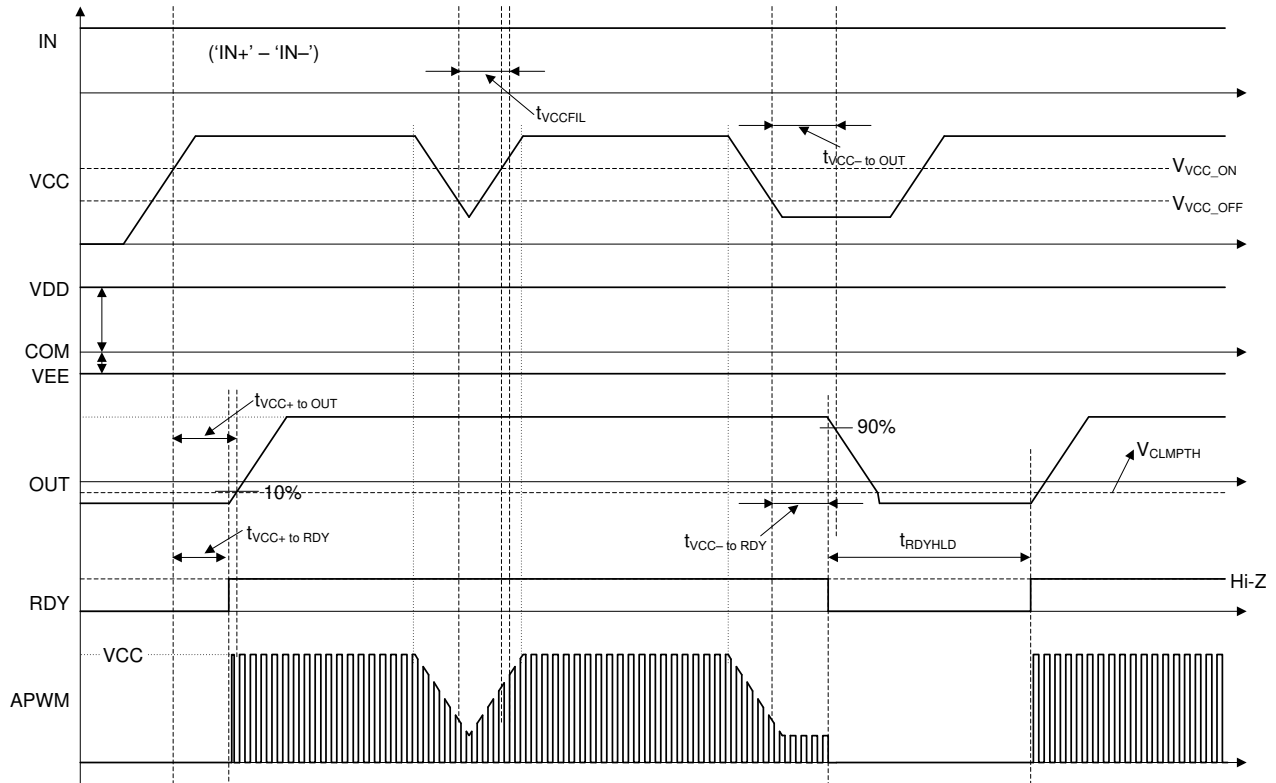

图 6-9. VDD UVLO Protection Timing Diagram

## 6.5 OC (Over Current) Protection

### 6.5.1 OC Protection with Soft Turn-OFF

OC Protection is used to sense the current of SiC-MOSFETs and IGBTs under over current or shoot-through condition. Figure 7-10 shows the timing diagram of OC operation with soft turn-off.

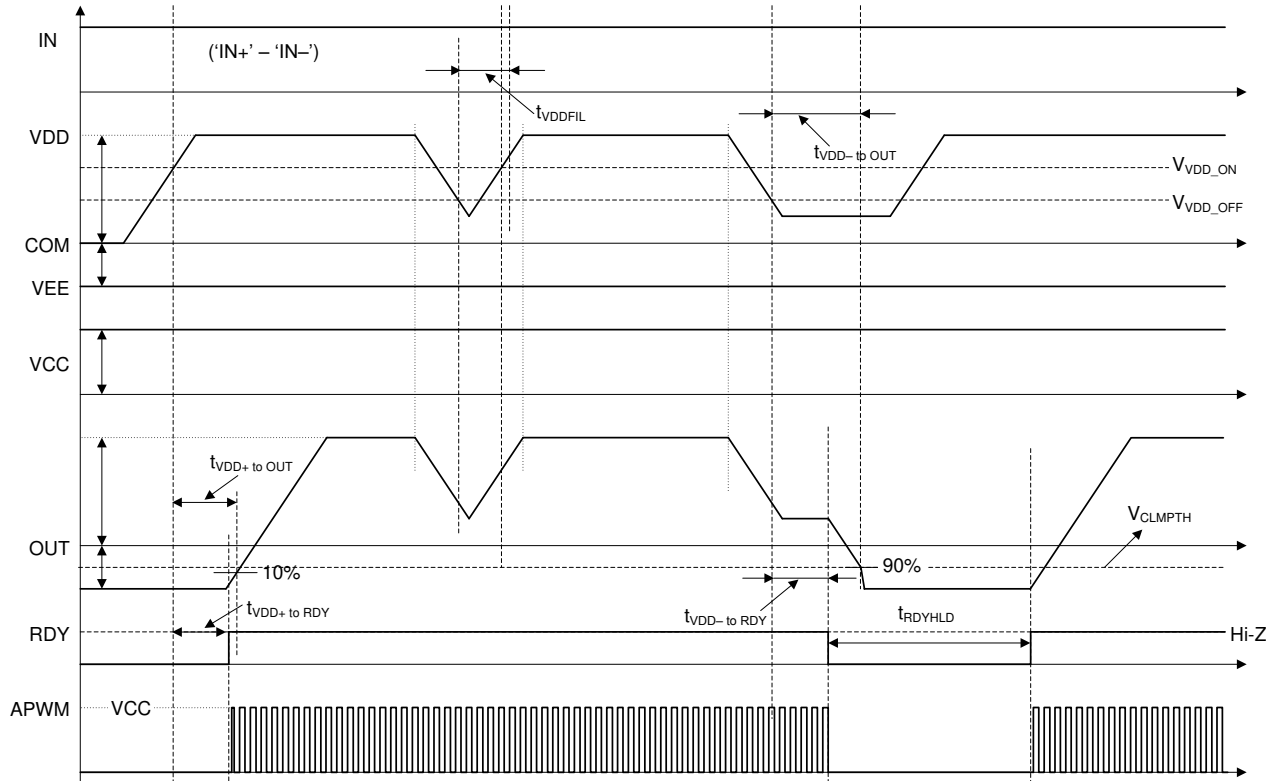

图 6-10. OC Protection with Soft Turn-OFF

## 7 Detailed Description

### 7.1 Overview

The UCC21710-Q1 device is an advanced isolated gate driver with state-of-the-art protection and sensing features for SiC MOSFETs and IGBTs. The device can support up to 2121-V DC operating voltage based on SiC MOSFETs and IGBTs, and can be used to above 10-kW applications such as HEV/EV traction inverter, motor drive, on-board and off-board battery charger, solar inverter, etc. The galvanic isolation is implemented by the capacitive isolation technology, which can realize a reliable reinforced isolation between the low voltage DSP/MCU and high voltage side.

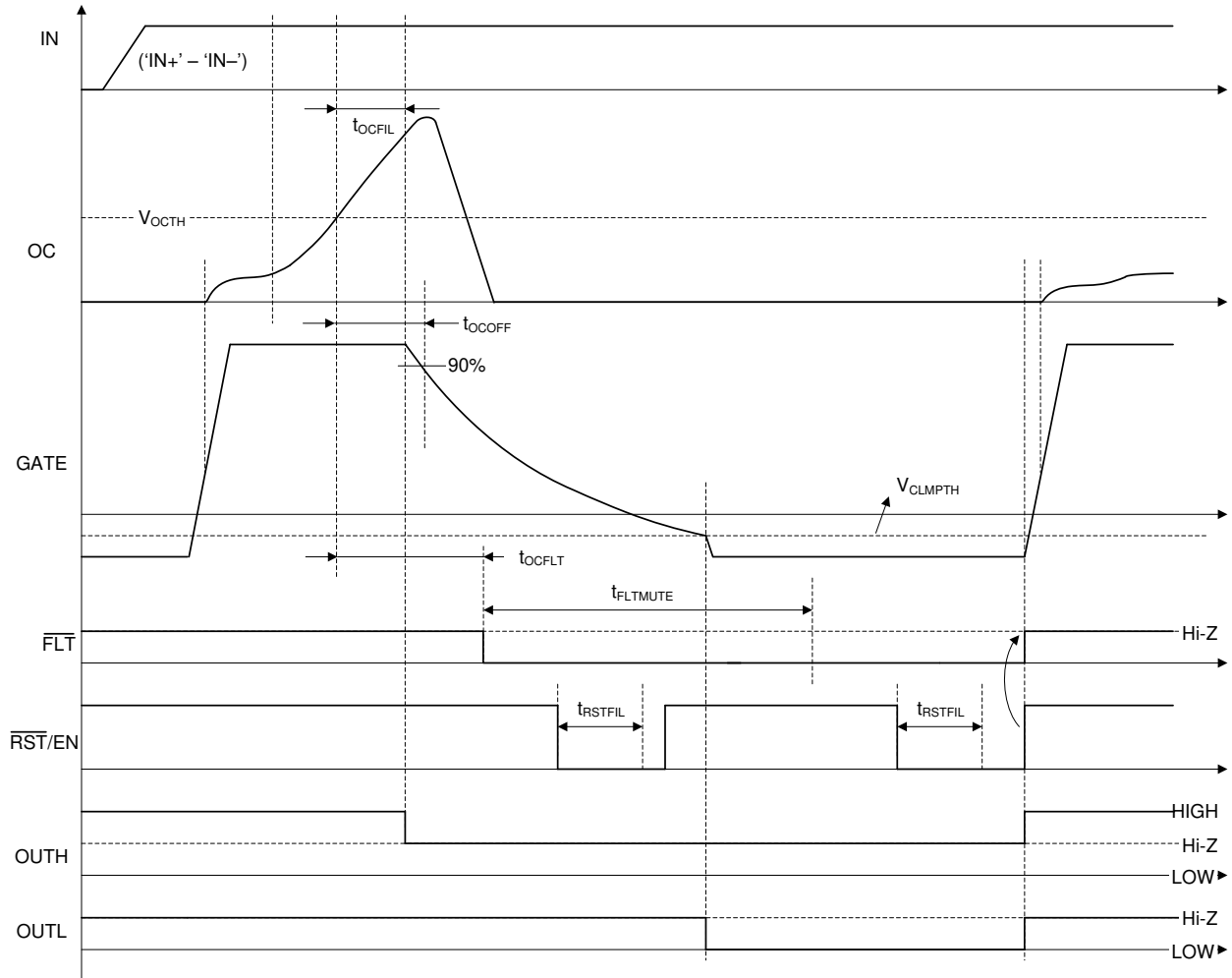
The  $\pm 10$ -A peak sink and source current of UCC21710-Q1 can drive the SiC MOSFET modules and IGBT modules directly without an extra buffer. The driver can also drive higher power modules or parallel modules with an external buffer stage. The input side is isolated with the output side with a reinforced isolation barrier, based on capacitive isolation technology. The device can support up to 1.5-kV<sub>RMS</sub> working voltage, 12.8-kV<sub>PK</sub> surge immunity with longer than 40 years isolation barrier life. The strong drive strength helps to switch the device fast and reduce the switching loss. While the 150-V/ns minimum CMTI guarantees the reliability of the system with fast switching speed. The small propagation delay and part-to-part skew can minimize the deadtime setting, so the conduction loss can be reduced.

The device includes extensive protection and monitor features to increase the reliability and robustness of the SiC MOSFET and IGBT based systems. The 12-V output side power supply UVLO is suitable for switches with gate voltage  $\geq 15$  V. The active miller clamp feature prevents the false turn on causing by Miller capacitance during fast switching. An external Miller clamp FET can be used, providing more versatility to the system design. The device has the state-of-the-art overcurrent and short circuit detection time, and fault reporting function to the low voltage side DSP/MCU. The soft turn-off is triggered when the overcurrent or short circuit fault is detected, minimizing the short circuit energy while reducing the overshoot voltage on the switches.

The isolated analog to PWM sensor can be used as a switch temperature sensing, DC bus voltage sensing, auxiliary power supply sensing, and so on. The PWM signal can be fed directly to DSP/MCU or through a low-pass-filter as an analog signal.



## 7.2 Functional Block Diagram

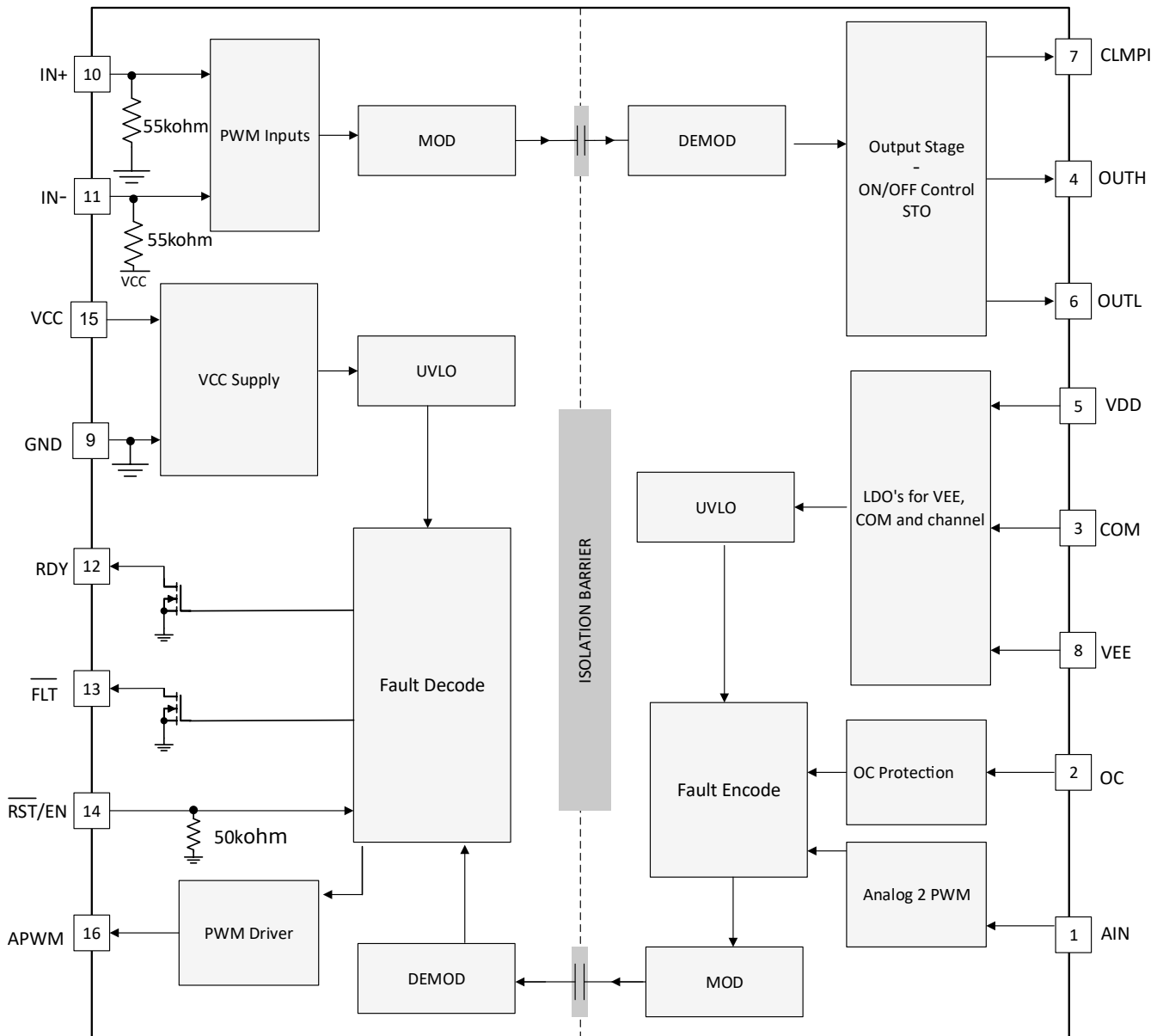

## 7.3 Feature Description

### 7.3.1 Power Supply

The input side power supply VCC can support a wide voltage range from 3V to 5.5V. The device supports both unipolar and bipolar power supply on the output side, with a wide range from 13V to 33V from VDD to VEE. The negative power supply with respect to switch source or emitter is usually adopted to avoid false turn on when the other switch in the phase leg is turned on. The negative voltage is especially important for SiC MOSFET due to its fast switching speed.

### 7.3.2 Driver Stage

UCC21710-Q1 has  $\pm 10A$  peak drive strength and is suitable for high power applications. The high drive strength can drive a SiC MOSFET module, IGBT module or paralleled discrete devices directly without extra buffer stage. UCC21710-Q1 can also be used to drive higher power modules or parallel modules with extra buffer stage. Regardless of the values of VDD, the peak sink and source current can be kept at 10A. The driver features an

important safety function wherein, when the input pins are in floating condition, the OUTH/OUTL is held in LOW state. The split output of the driver stage is depicted in [图 7-1](#). The driver has rail-to-rail output by implementing a hybrid pull-up structure with a P-Channel MOSFET in parallel with an N-Channel MOSFET, and an N-Channel MOSFET to pulldown. The pull-up NMOS is the same as the pull down NMOS, so the on resistance  $R_{NMOS}$  is the same as  $R_{OL}$ . The hybrid pull-up structure delivers the highest peak-source current when it is most needed, during the miller plateau region of the power semiconductor turn-on transient. The  $R_{OH}$  in [图 7-1](#) represents the on-resistance of the pull-up P-Channel MOSFET. However, the effective pull-up resistance is much smaller than  $R_{OH}$ . Since the pull-up N-Channel MOSFET has much smaller on-resistance than the P-Channel MOSFET, the pull-up N-Channel MOSFET dominates most of the turn-on transient, until the voltage on OUTH pin is about 3V below VDD voltage. The effective resistance of the hybrid pull-up structure during this period is about  $2 \times R_{OL}$ . Then the P-Channel MOSFET pulls up the OUTH voltage to VDD rail. The low pull-up impedance results in strong drive strength during the turn-on transient, which shortens the charging time of the input capacitance of the power semiconductor and reduces the turn on switching loss.

The pull-down structure of the driver stage is implemented solely by a pull-down N-Channel MOSFET. This MOSFET can ensure the OUTL voltage be pulled down to VEE rail. The low pull-down impedance not only results in high sink current to reduce the turn-off time, but also helps to increase the noise immunity considering the miller effect.

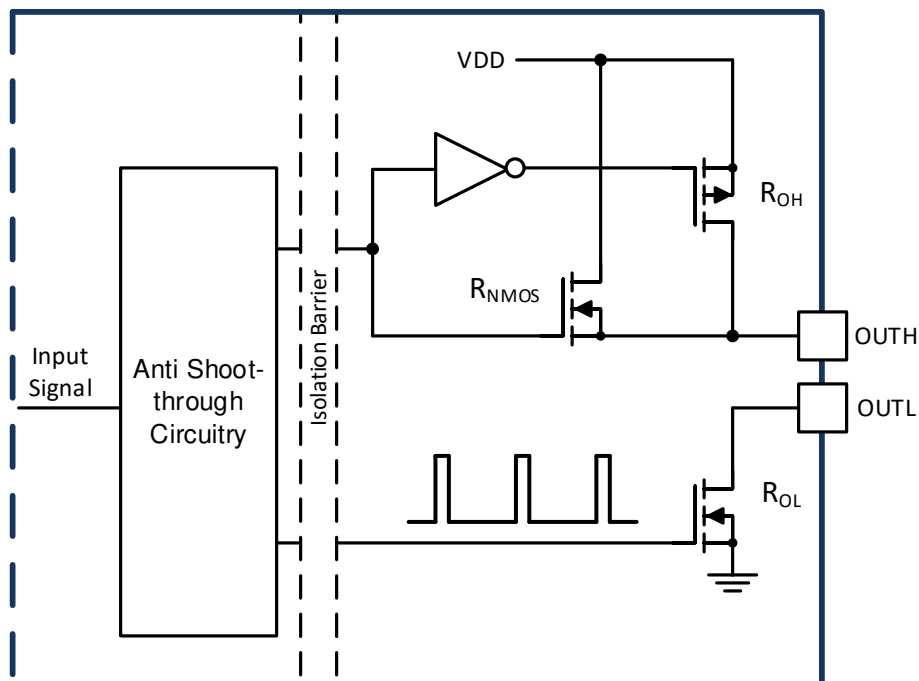

**图 7-1. Gate Driver Output Stage**

### 7.3.3 VCC and VDD Undervoltage Lockout (UVLO)

UCC21710-Q1 implements the internal UVLO protection feature for both input and output power supplies VCC and VDD. When the supply voltage is lower than the threshold voltage, the driver output is held as LOW. The output only goes HIGH when both VCC and VDD are out of the UVLO status. The UVLO protection feature not only reduces the power consumption of the driver itself during low power supply voltage condition, but also increases the efficiency of the power stage. For SiC MOSFET and IGBT, the on-resistance reduces while the gate-source voltage or gate-emitter voltage increases. If the power semiconductor is turned on with a low VDD value, the conduction loss increases significantly and can lead to a thermal issue and efficiency reduction of the power stage. UCC21710-Q1 implements 12V threshold voltage of VDD UVLO, with 800mV hysteresis. This threshold voltage is suitable for both SiC MOSFET and IGBT.

The UVLO protection block features with hysteresis and deglitch filter, which help to improve the noise immunity of the power supply. During the turn on and turn off switching transient, the driver sources and sinks a peak transient current from the power supply, which can result in sudden voltage drop of the power supply. With hysteresis and UVLO deglitch filter, the internal UVLO protection block will ignore small noises during the normal switching transients.

The timing diagrams of the UVLO feature of VCC and VDD are shown in Figure 7-8, and Figure 7-9. The RDY pin on the input side is used to indicate the power good condition. The RDY pin is open drain. During UVLO condition, the RDY pin is held in low status and connected to GND. Normally the pin is pulled up externally to VCC to indicate the power good. The AIN-APWM function stops working during the UVLO status. The APWM pin on the input side will be held LOW.

### 7.3.4 Active Pulldown

UCC21710-Q1 implements an active pulldown feature to ensure the OUTH/OUTL pin clamping to VEE when the VDD is open. The OUTH/OUTL pin is in high-impedance status when VDD is open, the active pulldown feature can prevent the output be false turned on before the device is back to control.



图 7-2. Active Pulldown

### 7.3.5 Short Circuit Clamping

During short circuit condition, the miller capacitance can cause a current sinking to the OUTH/OUTL pin due to the high  $dV/dt$  and boost the OUTH/OUTL voltage. The short circuit clamping feature of UCC21710-Q1 can clamp the OUTH/OUTL pin voltage to be slightly higher than VDD, which can protect the power semiconductors from a gate-source and gate-emitter overvoltage breakdown. This feature is realized by an internal diode from the OUTH/OUTL to VDD.

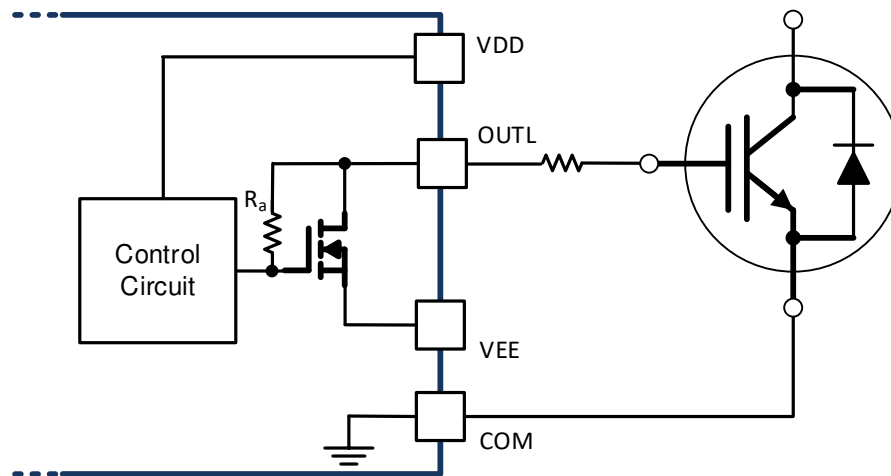

图 7-3. Short Circuit Clamping

### 7.3.6 Internal Active Miller Clamp

Active miller clamp feature is important to prevent the false turn-on while the driver is in OFF state. In applications which the device can be in synchronous rectifier mode, the body diode conducts the current during the deadtime while the device is in OFF state, the drain-source or collector-emitter voltage remains the same and the  $dV/dt$  happens when the other power semiconductor of the phase leg turns on. The low internal pull-down impedance of UCC21710-Q1 can provide a strong pulldown to hold the OUTL to VEE. However, external gate resistance is usually adopted to limit the  $dV/dt$ . The miller effect during the turn on transient of the other power semiconductor can cause a voltage drop on the external gate resistor, which boost the gate-source or gate-emitter voltage. If the voltage on  $V_{GS}$  or  $V_{GE}$  is higher than the threshold voltage of the power semiconductor, a shoot through can happen and cause catastrophic damage. The active miller clamp feature of UCC21710-Q1 drives an internal MOSFET, which connects to the device gate. The internal MOSFET is triggered when the gate voltage is lower than  $V_{CLMPH}$ , which is 2V above VEE, and creates a low impedance path to avoid the false turn on issue.

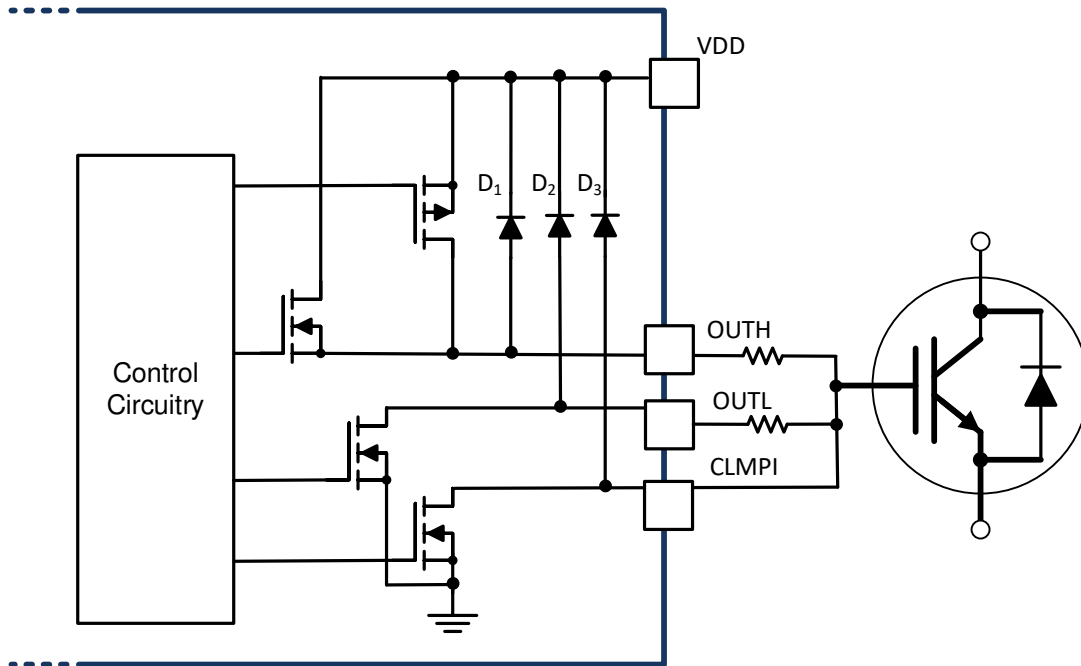

图 7-4. Active Miller Clamp

### 7.3.7 Overcurrent and Short Circuit Protection

The UCC21710-Q1 implements a fast overcurrent and short circuit protection feature to protect the SiC MOSFET or IGBT from catastrophic breakdown during fault. The OC pin of the device has a typical 0.7V threshold with respect to COM, source or emitter of the power semiconductor. When the input is in floating condition, or the output is held in low state, the OC pin is pulled down by an internal MOSFET and held in LOW state, which prevents the overcurrent and short circuit fault from false triggering. The OC pin is in high-impedance state when the output is in high state, which means the overcurrent and short circuit protection feature only works when the power semiconductor is in on state. The internal pulldown MOSFET helps to discharge the voltage of OC pin when the power semiconductor is turned off.

The overcurrent and short circuit protection feature can be used to SiC MOSFET module or IGBT module with SenseFET, traditional desaturation circuit and shunt resistor in series with the power loop for lower power applications, as shown in 图 7-5. For SiC MOSFET module or IGBT module with SenseFET, the SenseFET integrated in the module can scale down the drain current or collector current. With an external high precision sense resistor, the drain current or collector current can be accurately measured. If the voltage of the sensed resistor higher than the overcurrent threshold  $V_{OCTH}$  is detected, the soft turn-off is initiated. A fault will be reported to the input side  $\overline{FLT}$  pin to DSP/MCU. The output is held to LOW after the fault is detected, and can only be reset by the  $\overline{RST/EN}$  pin. The state-of-art overcurrent and short circuit detection time helps to ensure a short shutdown time for SiC MOSFET and IGBT.

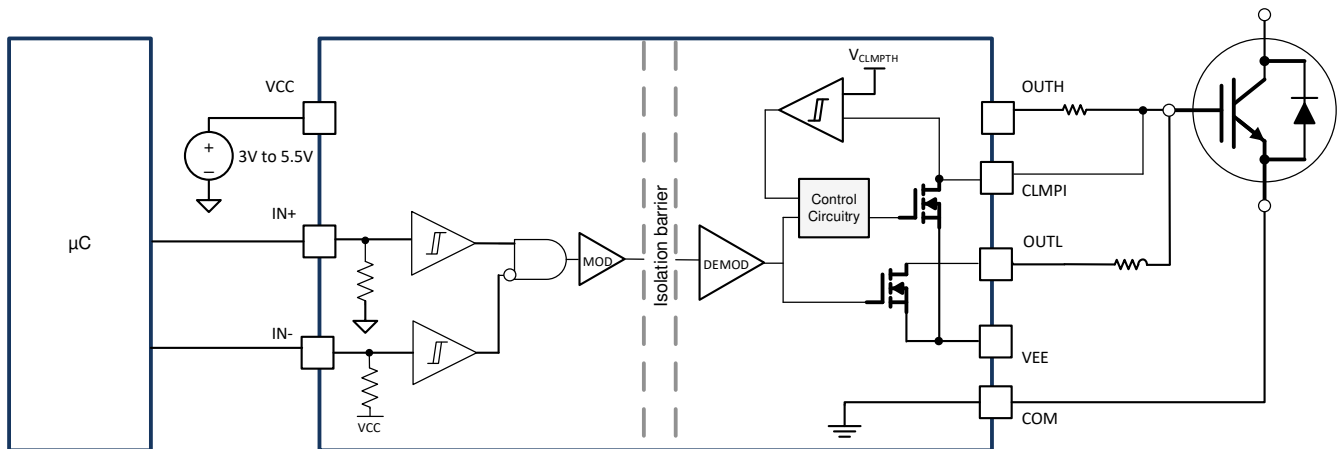
The overcurrent and short circuit protection feature can also be paired with desaturation circuit and shunt resistors. The DESAT threshold can be programmable in this case, which increases the versatility of the device. Detailed application diagrams of desaturation circuit and shunt resistor will be given in [Overcurrent and Short circuit Protection](#).

- High current and high  $di/dt$  during the overcurrent and short circuit fault can cause a voltage bounce on shunt resistor's parasitic inductance and board layout parasitic, which results in false trigger of OC pin. High precision, low ESL and small value resistor must be used in this approach.
- Shunt resistor approach is not recommended for high power applications and short circuit protection of the low power applications.

The detailed applications of the overcurrent and short circuit feature will be discussed in the Application and Implementation section.



图 7-5. Overcurrent and Short Circuit Protection

### 7.3.8 Soft Turn-off

UCC21710-Q1 initiates a soft turn-off when the overcurrent and short circuit protection is triggered. When the overcurrent and short circuit fault happens, the power semiconductor transits from the linear region to the saturation region very fast. The channel current is controlled by the gate voltage. By pulling down the gate voltage with a soft turn off current, the  $di/dt$  of the channel current is controlled by the gate voltage and decreasing in a soft manner, thus the overshoot of the power semiconductor is limited and prevents the overvoltage breakdown. The timing diagram of soft turn-off shows in Figure 7-10.

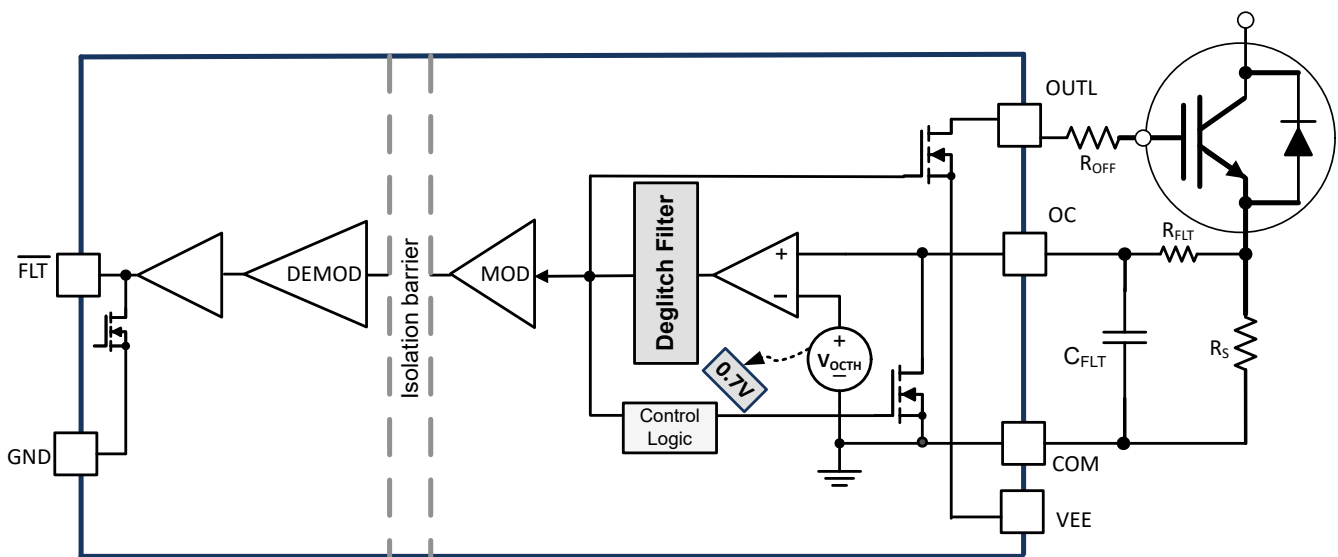

图 7-6. Soft Turn-off

### 7.3.9 Fault ( $\overline{FLT}$ , Reset and Enable ( $\overline{RST/EN}$ ))

The  $\overline{FLT}$  pin of UCC21710-Q1 is open drain and can report a fault signal to the DSP/MCU when the fault is detected through the OC pin. The  $\overline{FLT}$  pin will be pulled down to GND after the fault is detected, and is held low until a reset signal is received from  $\overline{RST/EN}$ . The device has a fault mute time  $t_{FLTMUTE}$ , within which the device ignores any reset signal.

The  $\overline{RST/EN}$  is pulled down internally by a  $50k\Omega$  resistor, and is thus disabled by default when this pin is floating. It must be pulled up externally to enable the driver. The pin has two purposes:

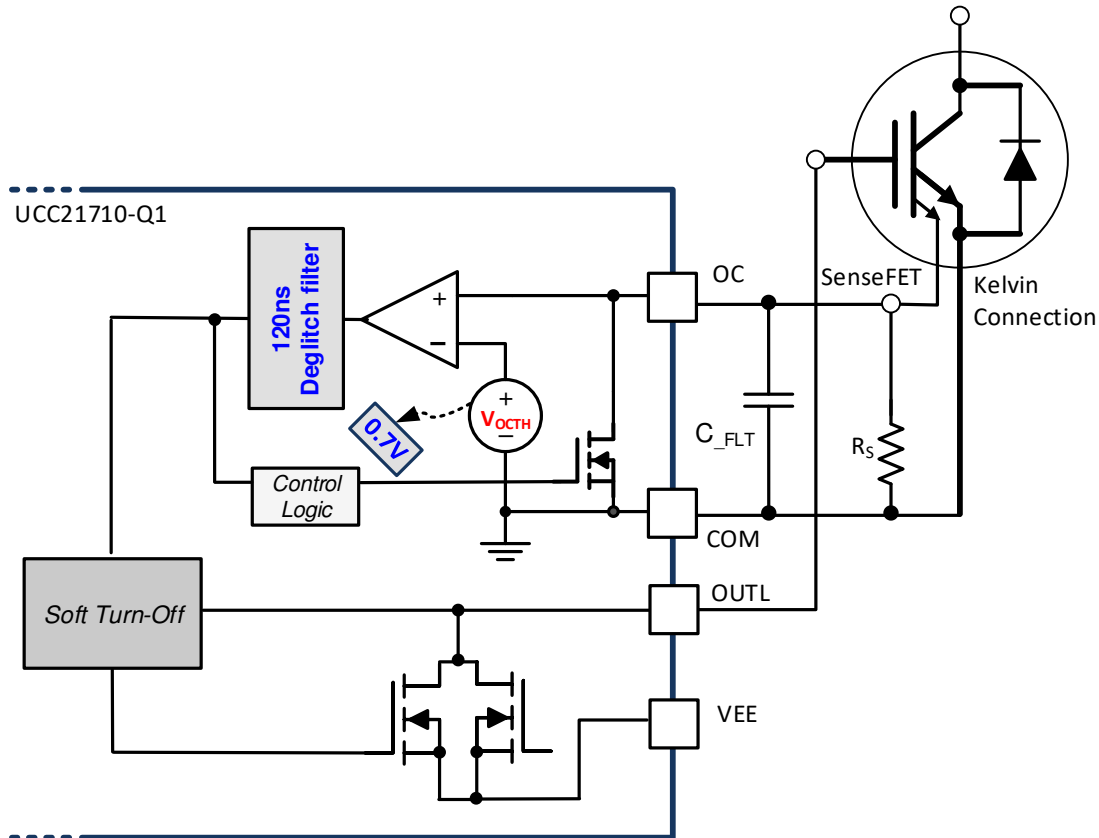
- To reset the  $\overline{FLT}$  pin. To reset, then  $\overline{RST/EN}$  pin is pulled low; if the pin is set and held in low state for more than  $t_{RSTFIL}$  after the mute time  $t_{FLTMUTE}$ , then the fault signal is reset and  $\overline{FLT}$  is reset back to the high impedance status at the rising edge of the input signal at  $\overline{RST/EN}$  pin.
- Enable and shutdown the device. If the  $\overline{RST/EN}$  pin is pulled low for longer than  $t_{RSTFIL}$ , the driver will be disabled and OUTL will be activated to pull down the gate of the IGBT or SiC MOSFET. The pin must be pulled up externally to enable the part, otherwise the device is disabled by default.

### 7.3.10 Isolated Analog to PWM Signal Function

The UCC21710-Q1 features an isolated analog to PWM signal function from AIN to APWM pin, which allows the isolated temperature sensing, high voltage dc bus voltage sensing, etc. An internal current source  $I_{AIN}$  in AIN pin is implemented in the device to bias an external thermal diode or temperature sensing resistor. The UCC21710-Q1 encodes the voltage signal  $V_{AIN}$  to a PWM signal, passing through the reinforced isolation barrier, and output to APWM pin on the input side. The PWM signal can either be transferred directly to DSP/MCU to calculate the duty cycle, or filtered by a simple RC filter as an analog signal. The AIN voltage input range is from 0.6V to 4.5V, and the corresponding duty cycle of the APWM output ranges from 88% to 10%. The duty cycle increases linearly from 10% to 88% while the AIN voltage decreases from 4.5V to 0.6V. This corresponds to the temperature coefficient of the negative temperature coefficient (NTC) resistor and thermal diode. When AIN is floating, the AIN voltage is 5V and the APWM operates at 400kHz with approximately 10% duty cycle. The accuracy of the duty cycle is  $\pm 3\%$  across temperature without one time calibration. The accuracy can be improved using calibration. The accuracy of the internal current source  $I_{AIN}$  is  $\pm 3\%$  across temperature.

The isolated analog to PWM signal feature can also support other analog signal sensing, such as the high voltage dc bus voltage, etc. The internal current source  $I_{AIN}$  should be taken into account when designing the potential divider if sensing a high voltage.



图 7-7. Isolated Analog to PWM Signal

## 7.4 Device Functional Modes

表 7-1 lists the device function.

表 7-1. Function Table

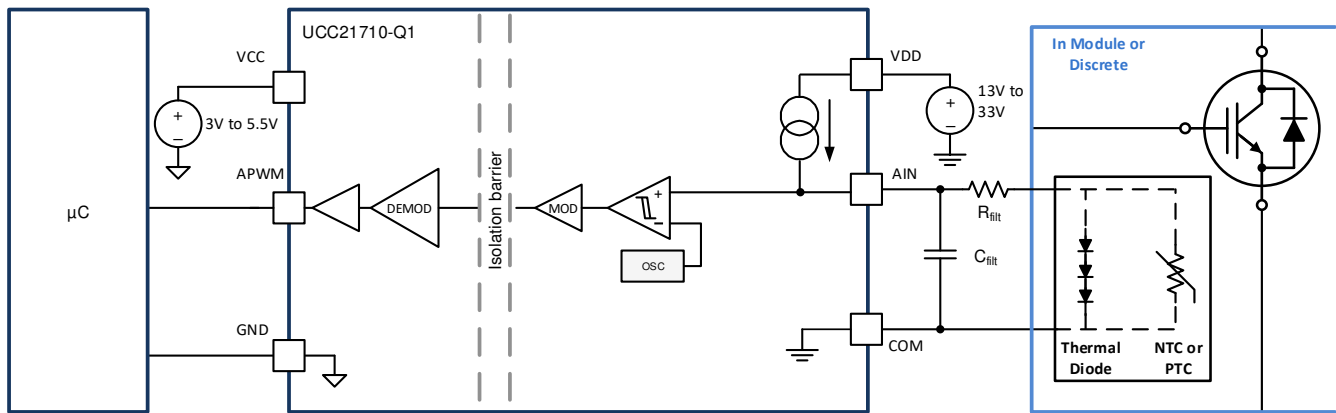
Input							Output				
VCC	VDD	VEE	IN+	IN-	RST/EN	AIN	RDY	FLT	OUTH/ OUTL	CLMPE	APWM
PU	PD	PU	X	X	X	X	Low	HiZ	Low	Low	Low
PD	PU	PU	X	X	X	X	Low	HiZ	Low	High	Low
PU	PU	PU	X	X	Low	X	HiZ	HiZ	Low	High	Low
PU	Open	PU	X	X	X	X	Low	HiZ	HiZ	HiZ	HiZ
PU	PU	Open	X	X	X	X	Low	HiZ	Low	High	Low
PU	PU	PU	Low	X	High	X	HiZ	HiZ	Low	High	P*
PU	PU	PU	X	High	High	X	HiZ	HiZ	Low	High	P*
PU	PU	PU	High	High	High	X	HiZ	HiZ	Low	High	P*
PU	PU	PU	High	Low	High	X	HiZ	HiZ	High	HiZ	P*

PU: Power Up ( $V_{CC} \geq 2.85V$ ,  $V_{DD} \geq 13.1V$ ,  $V_{EE} \leq 0V$ ); PD: Power Down ( $V_{CC} \leq 2.35V$ ,  $V_{DD} \leq 9.9V$ ); X: Irrelevant; P\*: PWM Pulse; HiZ: High Impedance



## 8 Applications and Implementation

### 备注

以下应用部分中的信息不属于 TI 器件规格的范围，TI 不担保其准确性和完整性。TI 的客户应负责确定器件是否适用于其应用。客户应验证并测试其设计，以确保系统功能。

### 8.1 Application Information

The UCC21710-Q1 device is very versatile because of the strong drive strength, wide range of output power supply, high isolation ratings, high CMTI and superior protection and sensing features. The 1.5-kVRMS working voltage and 12.8-kVPK surge immunity can support up both SiC MOSFET and IGBT modules with DC bus voltage up to 2121V. The device can be used in both low power and high power applications such as the traction inverter in HEV/EV, on-board charger and charging pile, motor driver, solar inverter, industrial power supplies and etc. The device can drive the high power SiC MOSFET module, IGBT module or paralleled discrete device directly without external buffer drive circuit based on NPN/PNP bipolar transistor in totem-pole structure, which allows the driver to have more control to the power semiconductor and saves the cost and space of the board design. UCC21710-Q1 can also be used to drive very high power modules or paralleled modules with external buffer stage. The input side can support power supply and microcontroller signal from 3.3V to 5V, and the device level shifts the signal to output side through reinforced isolation barrier. The device has wide output power supply range from 13V to 33V and support wide range of negative power supply. This allows the driver to be used in SiC MOSFET applications, IGBT application and many others. The 12V UVLO benefits the power semiconductor with lower conduction loss and improves the system efficiency. As a reinforced isolated single channel driver, the device can be used to drive either a low-side or high-side driver.

UCC21710-Q1 device features extensive protection and monitoring features, which can monitor, report and protect the system from various fault conditions.

- Fast detection and protection for the overcurrent and short circuit fault. The feature is preferable in a split source SiC MOSFET module or a split emitter IGBT module. For the modules with no integrated current mirror or paralleled discrete semiconductors, the traditional desaturation circuit can be modified to implement short circuit protection. The semiconductor is shutdown when the fault is detected and FLT pin is pulled down to indicate the fault detection. The device is latched unless reset signal is received from the RST/EN pin.
- Soft turn-off feature to protect the power semiconductor from catastrophic breakdown during overcurrent and short circuit fault. The shutdown energy can be controlled while the overshoot of the power semiconductor is limited.
- UVLO detection to protect the semiconductor from excessive conduction loss. Once the device is detected to be in UVLO mode, the output is pulled down and RDY pin indicates the power supply is lost. The device is back to normal operation mode once the power supply is out of the UVLO status. The power good status can be monitored from the RDY pin.
- Analog signal sensing with isolated analog to PWM signal feature. This feature allows the device to sense the temperature of the semiconductor from the thermal diode or temperature sensing resistor, or dc bus voltage with resistor divider. A PWM signal is generated on the low voltage side with reinforced isolated from the high voltage side. The signal can be fed back to the microcontroller for the temperature monitoring, voltage monitoring and etc.
- The active miller clamp feature protects the power semiconductor from false turn on by driving an external MOSFET. This feature allows the flexibility of the board layout design and the pulldown strength of miller clamp FET.
- Enable and disable function through the  $\overline{\text{RST/EN}}$  pin.
- Short circuit clamping.
- Active pulldown.

## 8.2 Typical Application

图 8-1 展示了半桥的典型应用，使用两个 UCC21710-Q1 隔离栅极驱动器。半桥是各种功率电子应用的基本元素，例如牵引逆变器在 HEV/EV 中将电动汽车电池的 DC 电流转换为驱动推进系统中 AC 电机的 AC 电流。该拓扑也可用于电机驱动应用，以控制 AC 电机的运行速度和扭矩。



图 8-1. Typical Application Schematic

### 8.2.1 Design Requirements

The design of the power system for end equipment should consider some design requirements to ensure the reliable operation of UCC21710-Q1 through the load range. The design considerations include the peak source and sink current, power dissipation, overcurrent and short circuit protection, AIN-APWM function for analog signal sensing and etc.

A design example for a half bridge based on IGBT is given in this subsection. The design parameters are shown in 表 8-1.

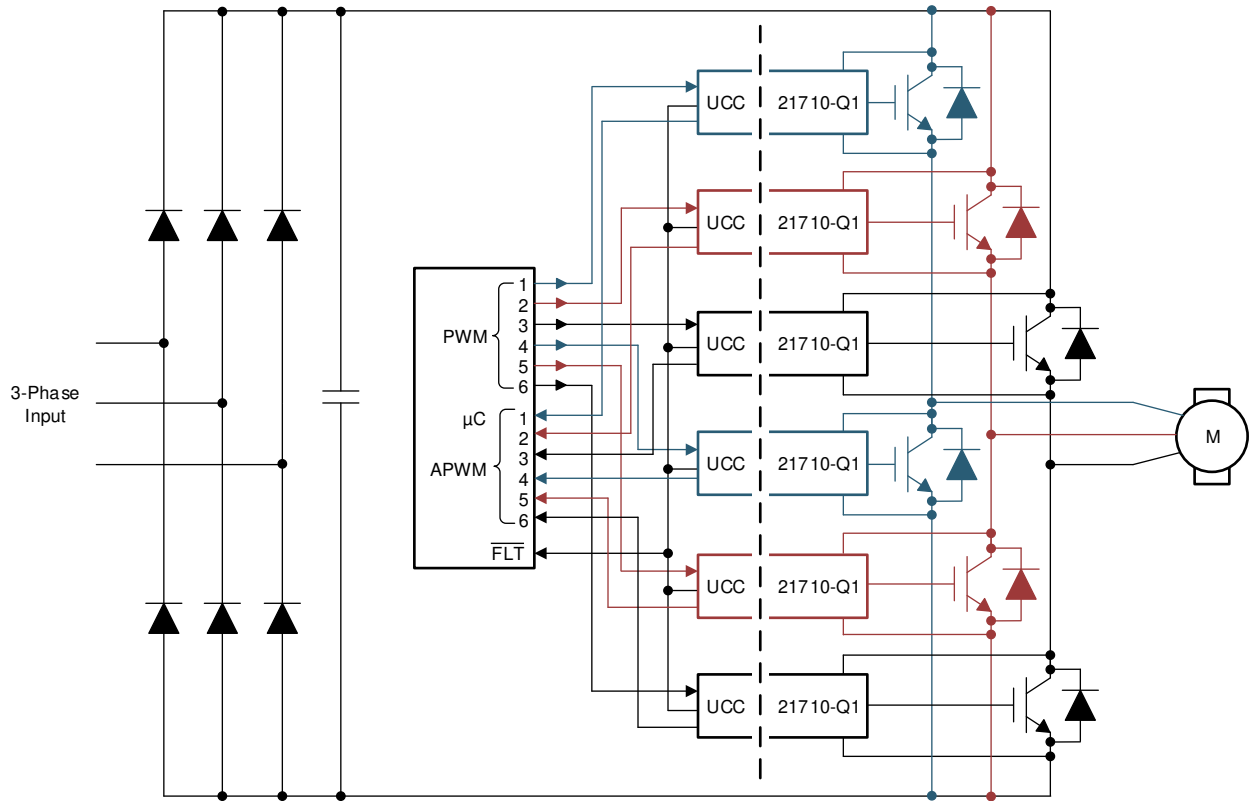
表 8-1. Design Parameters

Parameter	Value
Input Supply Voltage	5V
IN-OUT Configuration	Non-inverting
Positive Output Voltage VDD	15V
Negative Output Voltage VEE	-5V
DC Bus Voltage	800V
Peak Drain Current	300A
Switching Frequency	50kHz

表 8-1. Design Parameters (续)

Parameter	Value
Switch Type	IGBT Module

## 8.2.2 Detailed Design Procedure

### 8.2.2.1 Input filters for IN+, IN- and $\overline{RST/EN}$

In the applications of traction inverter or motor drive, the power semiconductors are in hard switching mode. With the strong drive strength of UCC21710-Q1, the  $dV/dt$  can be high, especially for SiC MOSFET. Noise can not only be coupled to the gate voltage due to the parasitic inductance, but also to the input side as the non-ideal PCB layout and coupled capacitance.

UCC21710-Q1 features a 40ns internal deglitch filter to IN+, IN- and  $\overline{RST/EN}$  pin. Any signal less than 40ns can be filtered out from the input pins. For noisy systems, external low pass filter can be added externally to the input pins. Adding low pass filters to IN+, IN- and  $\overline{RST/EN}$  pins can effectively increase the noise immunity and increase the signal integrity. When not in use, the IN+, IN- and  $\overline{RST/EN}$  pins should not be floating. IN- should be tied to GND if only IN+ is used for non-inverting input to output configuration. The purpose of the low pass filter is to filter out the high frequency noise generated by the layout parasitics. While choosing the low pass filter resistors and capacitors, both the noise immunity effect and delay time should be considered according to the system requirements.

### 8.2.2.2 PWM Interlock of IN+ and IN-

UCC21710-Q1 features the PWM interlock for IN+ and IN- pins, which can be used to prevent the phase leg shoot through issue. As shown in 表 7-1, the output is logic low while both IN+ and IN- are logic high. When only IN+ is used, IN- can be tied to GND. To utilize the PWM interlock function, the PWM signal of the other switch in the phase leg can be sent to the IN- pin. As shown in 图 8-2, the PWM\_T is the PWM signal to top side switch, the PWM\_B is the PWM signal to bottom side switch. For the top side gate driver, the PWM\_T signal is given to the IN+ pin, while the PWM\_B signal is given to the IN- pin; for the bottom side gate driver, the PWM\_B signal is given to the IN+ pin, while PWM\_T signal is given to the IN- pin. When both PWM\_T and PWM\_B signals are high, the outputs of both gate drivers are logic low to prevent the shoot through condition.



图 8-2. PWM Interlock for a Half Bridge

### 8.2.2.3 $\overline{\text{FLT}}$ , RDY and $\overline{\text{RST/EN}}$ Pin Circuitry

Both  $\overline{\text{FLT}}$  and RDY pin are open-drain output. The  $\overline{\text{RST/EN}}$  pin has  $50\text{k}\Omega$  internal pull-down resistor, so the driver is in OFF status if the  $\overline{\text{RST/EN}}$  pin is not pulled up externally. A  $5\text{k}\Omega$  resistor can be used as pullup resistor for the  $\overline{\text{FLT}}$ , RDY and  $\overline{\text{RST/EN}}$  pins.

To improve the noise immunity due to the parasitic coupling and common mode noise, low pass filters can be added between the  $\overline{\text{FLT}}$ , RDY and  $\overline{\text{RST/EN}}$  pins and the microcontroller. A filter capacitor between  $100\text{pF}$  to  $300\text{pF}$  can be added.

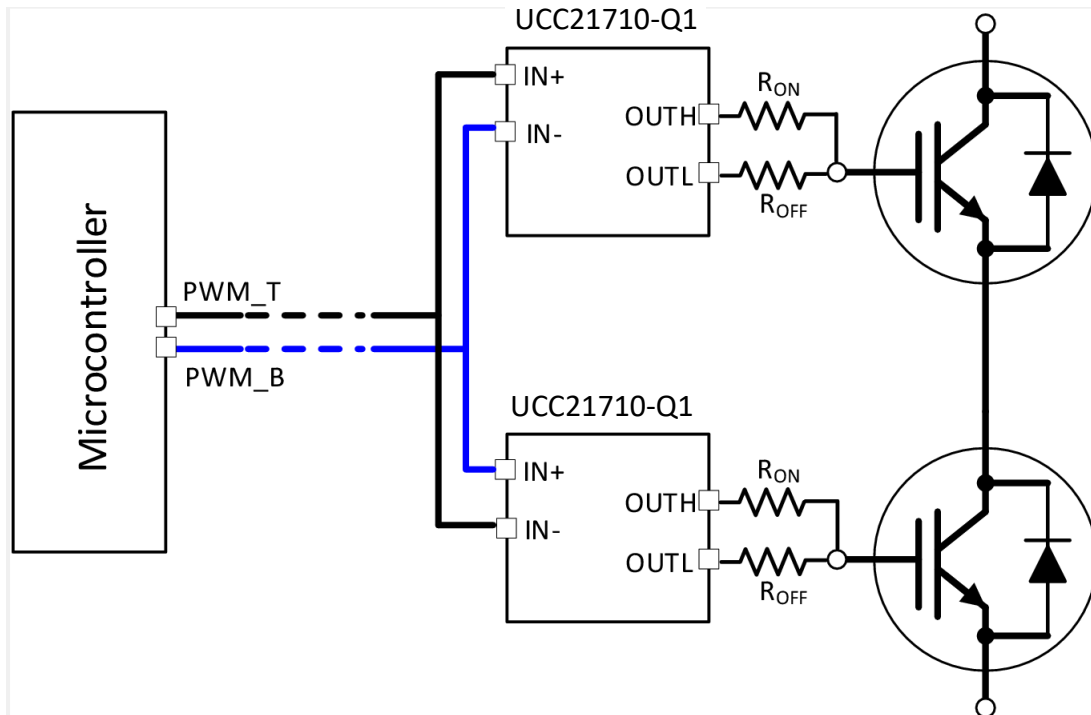

图 8-3.  $\overline{\text{FLT}}$ , RDY and  $\overline{\text{RST/EN}}$  Pins Circuitry

### 8.2.2.4 $\overline{\text{RST/EN}}$ Pin Control

$\overline{\text{RST/EN}}$  pin has two functions. It is used to enable or shutdown the outputs of the driver and to reset the fault signaled on the  $\overline{\text{FLT}}$  pin after OC is detected.  $\overline{\text{RST/EN}}$  pin needs to be pulled up to enable the device; when the pin is pulled down, the device is in disabled status. By default the driver is disabled with the internal  $50\text{k}\Omega$  pull-down resistor at this pin.

When the driver is latched after overcurrent or short circuit fault is detected, the  $\overline{\text{FLT}}$  pin and output are latched low and need to be reset by the  $\overline{\text{RST/EN}}$  pin. The microcontroller must send a signal to  $\overline{\text{RST/EN}}$  pin after the fault to reset the driver. The driver will not respond until after the mute time  $t_{\text{FLTMUTE}}$ . The reset signal must be held low for at least  $t_{\text{RSTFIL}}$  after the mute time.

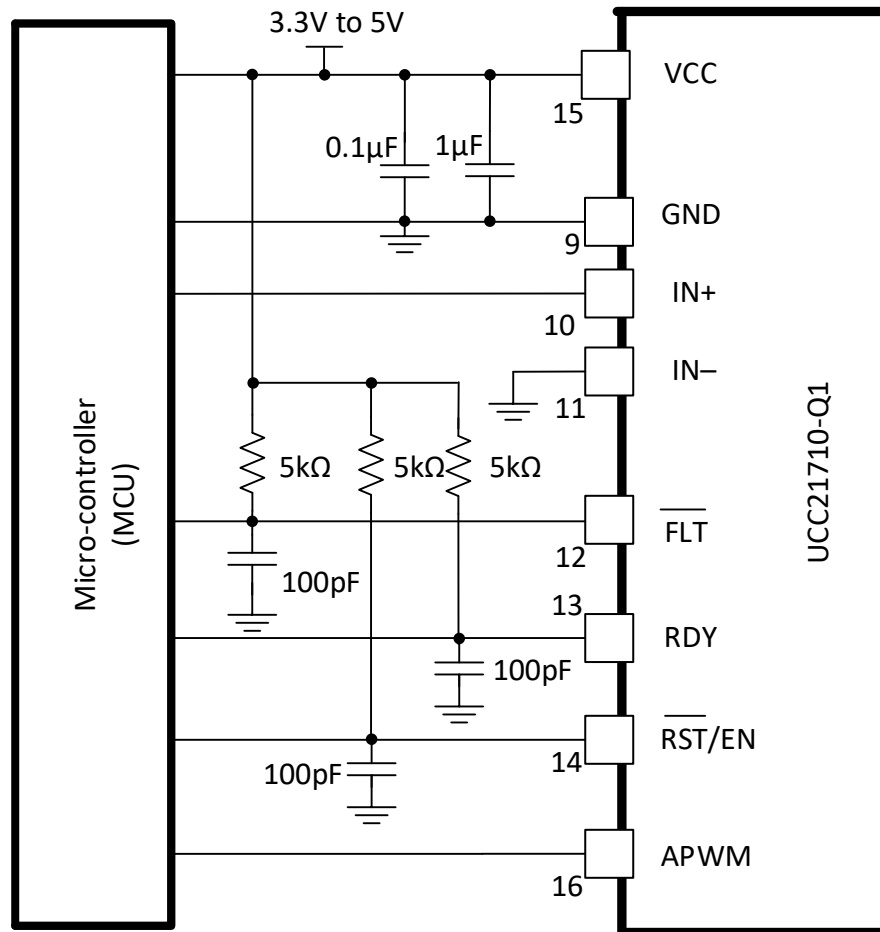
This pin can also be used to automatically reset the driver. The continuous input signal IN+ or IN- can be applied to  $\overline{\text{RST/EN}}$  pin. There is no separate reset signal from the microcontroller when configuring the driver this way. If the PWM is applied to the non-inverting input IN+, then IN+ can also be tied to  $\overline{\text{RST/EN}}$  pin. If the PWM is

applied to the inverting input IN-, then a NOT logic is needed between the PWM signal from the microcontroller and the RST/EN pin. Using either configuration results in the driver being reset in every switching cycle without an extra control signal from microcontroller tied to RST/EN pin. One must ensure the PWM off-time is greater than  $t_{RSTFIL}$  in order to reset the driver in cause of a OC fault.



图 8-4. Automatic Reset Control

### 8.2.2.5 Turn on and turn off gate resistors

UCC21710-Q1 features split outputs OUTH and OUTL, which enables the independent control of the turn on and turn off switching speed. The turn on and turn off resistance determine the peak source and sink current, which controls the switching speed in turn. Meanwhile, the power dissipation in the gate driver should be considered to ensure the device is in the thermal limit. At first, the peak source and sink current are calculated as:

$$I_{\text{source\_pk}} = \min\left(10\text{A}, \frac{V_{\text{DD}} - V_{\text{EE}}}{R_{\text{OH\_EFF}} + R_{\text{ON}} + R_{\text{G\_Int}}}\right)$$

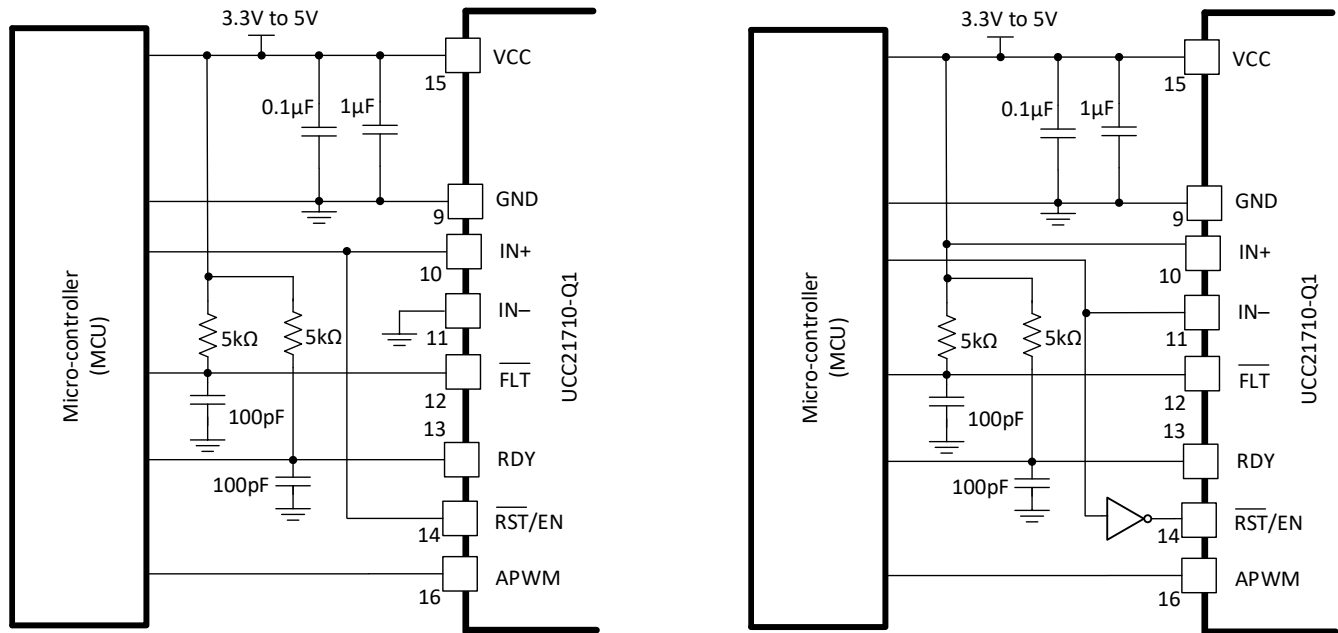
$$I_{\text{sink\_pk}} = \min\left(10\text{A}, \frac{V_{\text{DD}} - V_{\text{EE}}}{R_{\text{OL}} + R_{\text{OFF}} + R_{\text{G\_Int}}}\right) \quad (1)$$

Where

- $R_{\text{OH\_EFF}}$  is the effective internal pull up resistance of the hybrid pull-up structure, which is approximately  $2 \times R_{\text{OL}}$ , about  $0.7 \Omega$
- $R_{\text{OL}}$  is the internal pulldown resistance, about  $0.3 \Omega$
- $R_{\text{ON}}$  is the external turn on gate resistance
- $R_{\text{OFF}}$  is the external turn off gate resistance
- $R_{\text{G\_Int}}$  is the internal resistance of the SiC MOSFET or IGBT module



图 8-5. Output Model for Calculating Peak Gate Current

For example, for an IGBT module based system with the following parameters:

- $Q_g = 3300 \text{ nC}$
- $R_{G\_Int} = 1.7 \Omega$
- $R_{ON}=R_{OFF}= 1 \Omega$

The peak source and sink current in this case are:

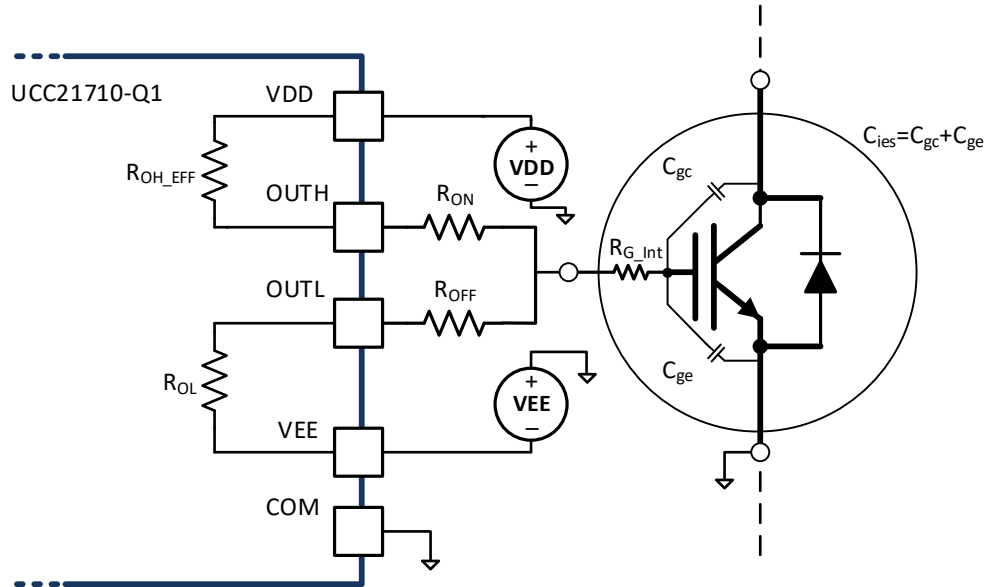
$$I_{\text{source\_pk}} = \min\left(10\text{A}, \frac{V_{\text{DD}} - V_{\text{EE}}}{R_{\text{OH\_EFF}} + R_{\text{ON}} + R_{\text{G\_Int}}}\right) \approx 5.9\text{A}$$

$$I_{\text{sink\_pk}} = \min\left(10\text{A}, \frac{V_{\text{DD}} - V_{\text{EE}}}{R_{\text{OL}} + R_{\text{OFF}} + R_{\text{G\_Int}}}\right) \approx 6.7\text{A} \tag{2}$$

Thus by using  $1 \Omega$  external gate resistance, the peak source current is 5.9A, the peak sink current is 6.7A. The collector-to-emitter  $dV/dt$  during the turn on switching transient is dominated by the gate current at the miller plateau voltage. The hybrid pullup structure ensures the peak source current at the miller plateau voltage, unless the turn on gate resistor is too high. The faster the collector-to-emitter,  $V_{ce}$ , voltage rises to  $V_{DC}$ , the smaller the turn on switching loss is. The  $dV/dt$  can be estimated as  $Q_{gc}/I_{\text{source\_pk}}$ . For the turn off switching transient, the drain-to-source  $dV/dt$  is dominated by the load current, unless the turn off gate resistor is too high. After  $V_{ce}$  reaches the dc bus voltage, the power semiconductor is in saturation mode and the channel current is controlled by  $V_{ge}$ . The peak sink current determines the  $dI/dt$ , which dominates the  $V_{ce}$  voltage overshoot accordingly. If using relatively large turn off gate resistance, the  $V_{ce}$  overshoot can be limited. The overshoot can be estimated by:

$$\Delta V_{ce} = L_{\text{stray}} \cdot I_{\text{load}} / ((R_{\text{OFF}} + R_{\text{OL}} + R_{\text{G\_Int}}) \cdot C_{\text{ies}} \cdot \ln(V_{\text{plat}} / V_{\text{th}})) \tag{3}$$

Where

- $L_{\text{stray}}$  is the stray inductance in power switching loop, as shown in 图 8-6
- $I_{\text{load}}$  is the load current, which is the turn off current of the power semiconductor
- $C_{\text{ies}}$  is the input capacitance of the power semiconductor
- $V_{\text{plat}}$  is the plateau voltage of the power semiconductor

- $V_{th}$  is the threshold voltage of the power semiconductor



图 8-6. Stray Parasitic Inductance of IGBTs in a Half-Bridge Configuration

The power dissipation should be taken into account to maintain the gate driver within the thermal limit. The power loss of the gate driver includes the quiescent loss and the switching loss, which can be calculated as:

$$P_{DR} = P_Q + P_{SW} \quad (4)$$

$P_Q$  is the quiescent power loss for the driver, which is  $I_q \times (VDD - VEE) = 5\text{mA} \times 20\text{V} = 0.100\text{W}$ . The quiescent power loss is the power consumed by the internal circuits such as the input stage, reference voltage, logic circuits, protection circuits when the driver is switching when the driver is biased with VDD and VEE, and also the charging and discharging current of the internal circuit when the driver is switching. The power dissipation when the driver is switching can be calculated as:

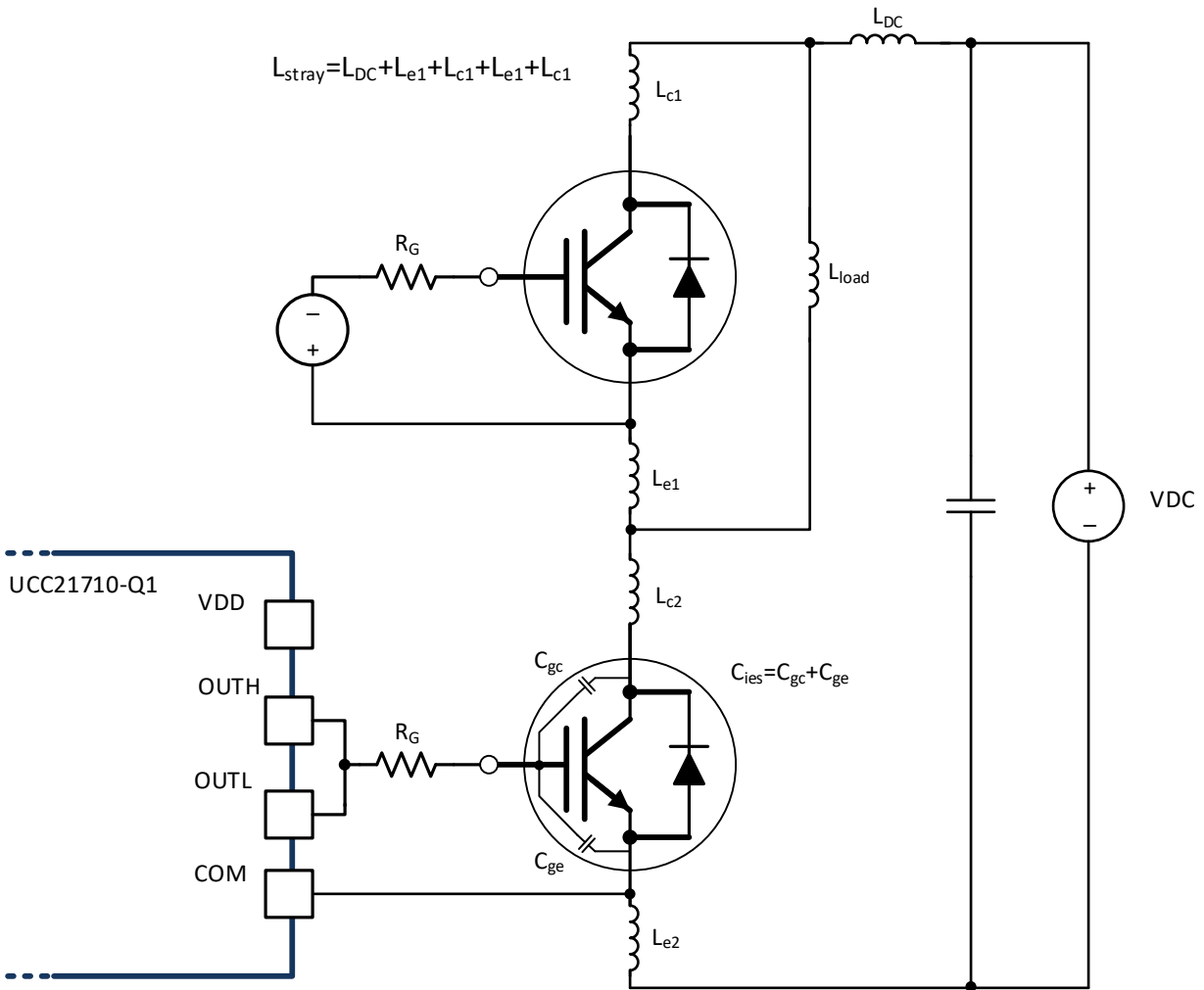
$$P_{SW} = \frac{1}{2} \cdot \left( \frac{R_{OH\_EFF}}{R_{OH\_EFF} + R_{ON} + R_{G\_Int}} + \frac{R_{OL}}{R_{OL} + R_{OFF} + R_{G\_Int}} \right) \cdot (VDD - VEE) \cdot f_{sw} \cdot Q_g \quad (5)$$

Where

- $Q_g$  is the gate charge required at the operation point to fully charge the gate voltage from VEE to VDD
- $f_{sw}$  is the switching frequency

In this example, the  $P_{SW}$  can be calculated as:

$$P_{SW} = \frac{1}{2} \cdot \left( \frac{R_{OH\_EFF}}{R_{OH\_EFF} + R_{ON} + R_{G\_Int}} + \frac{R_{OL}}{R_{OL} + R_{OFF} + R_{G\_Int}} \right) \cdot (VDD - VEE) \cdot f_{sw} \cdot Q_g = 0.505W \quad (6)$$

Thus, the total power loss is:

$$P_{DR} = P_Q + P_{SW} = 0.10W + 0.505W = 0.605W \quad (7)$$

When the board temperature is 125°C, the junction temperature can be estimated as:

$$T_j = T_b + \psi_{jb} \cdot P_{DR} \approx 150^\circ C \quad (8)$$

Therefore, for the application in this example, with 125°C board temperature, the maximum switching frequency is ~50kHz to keep the gate driver in the thermal limit. By using a lower switching frequency, or increasing external gate resistance, the gate driver can be operated at a higher switching frequency.

### 8.2.2.6 Overcurrent and Short Circuit Protection

Fast and reliable overcurrent and short circuit protection is important to protect the catastrophic break down of the SiC MOSFET and IGBT modules, and improve the system reliability. The UCC21710-Q1 features a state-of-art overcurrent and short circuit protection, which can be applied to both SiC MOSFET and IGBT modules with various detection circuits.

#### 8.2.2.6.1 Protection Based on Power Modules with Integrated SenseFET

The overcurrent and short circuit protection function is suitable for the SiC MOSFET and IGBT modules with integrated SenseFET. The SenseFET scales down the main power loop current and outputs the current with a dedicated pin of the power module. With external high precision sensing resistor, the scaled down current can be measured and the main power loop current can be calculated. The value of the sensing resistor  $R_S$  sets the protection threshold of the main current. For example, with a ratio of 1:N = 1:50000 of the integrated current mirror, by using the  $R_S$  as 20Ω, the threshold protection current is:

$$I_{OC\_TH} = \frac{V_{OCTH}}{R_S} \cdot N = 1750A \quad (9)$$

The overcurrent and short circuit protection based on integrated SenseFET has high precision, as it is sensing the current directly. The accuracy of the method is related to two factors: the scaling down ratio of the main power loop current and the SenseFET, and the precision of the sensing resistor. Since the current is sensed from the SenseFET, which is isolated from the main power loop, and the current is scaled down significantly with much less  $di/dt$ , the sensing loop has good noise immunity. To further improve the noise immunity, a low pass filter can be added. A 100pF to 10nF filter capacitor can be added. The delay time caused by the low pass filter should also be considered for the protection circuitry design.





图 8-7. Overcurrent and Short Circuit Protection Based on IGBT Module with SenseFET

#### 8.2.2.6.2 Protection Based on Desaturation Circuit

For SiC MOSFET and IGBT modules without SenseFET, desaturation (DESAT) circuit is the most popular circuit which is adopted for overcurrent and short circuit protection. The circuit consists of a current source, a resistor, a blanking capacitor and a diode. Normally the current source is provided from the gate driver, when the device turns on, a current source charges the blanking capacitor and the diode forward biased. During normal operation, the capacitor voltage is clamped by the switch  $V_{CE}$  voltage. When short circuit happens, the capacitor voltage is quickly charged to the threshold voltage which triggers the device shutdown. For the UCC21710-Q1, the OC pin does not feature an internal current source. The current source should be generated externally from the output power supply. When UCC21710-Q1 is in OFF state, the OC pin is pulled down by an internal MOSFET, which creates an offset voltage on OC pin. By choosing  $R_1$  and  $R_2$  significantly higher than the pulldown resistance of the internal MOSFET, the offset can be ignored. When UCC21710-Q1 is in ON state, the OC pin is high impedance. The current source is generated by the output power supply VDD and the external resistor divider  $R_1$ ,  $R_2$  and  $R_3$ . The overcurrent detection threshold voltage of the IGBT is:

$$V_{DET} = V_{OCTH} \cdot \frac{R_2 + R_3}{R_3} - V_F \quad (10)$$

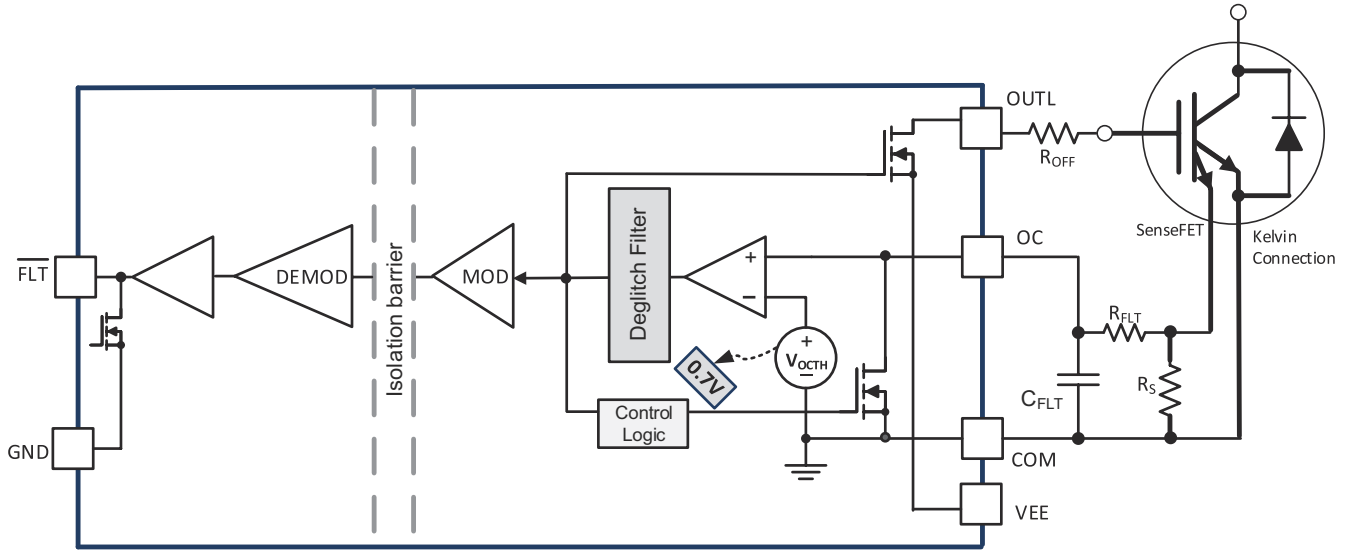
The blanking time of the detection circuit is:

$$t_{BLK} = -\frac{R_1 + R_2}{R_1 + R_2 + R_3} \cdot R_3 \cdot C_{BLK} \cdot \ln\left(1 - \frac{R_1 + R_2 + R_3}{R_3} \cdot \frac{V_{OCTH}}{V_{DD}}\right) \quad (11)$$

Where:

- $V_{OCTH}$  is the detection threshold voltage of the gate driver
- $R_1$ ,  $R_2$  and  $R_3$  are the resistance of the voltage divider
- $C_{BLK}$  is the blanking capacitor
- $V_F$  is the forward voltage of the high voltage diode  $D_{HV}$

The modified desaturation circuit has all the benefits of the conventional desaturation circuit. The circuit has negligible power loss, and is easy to implement. The detection threshold voltage of IGBT and blanking time can be programmed by external components. Different with the conventional desaturation circuit, the overcurrent detection threshold voltage of the IGBT can be modified to any voltage level, either higher or lower than the

detection threshold voltage of the driver. A parallel schottky diode can be connected between OC and COM pins to prevent the negative voltage on the OC pin in noisy system. Since the desaturation circuit measures the  $V_{CE}$  of the IGBT or  $V_{DS}$  of the SiC MOSFET, not directly the current, the accuracy of the protection is not as high as the SenseFET based protection method. The current threshold cannot be accurately controlled in the protection.



图 8-8. Overcurrent and Short Circuit Protection Based on Desaturation Circuit

#### 8.2.2.6.3 Protection Based on Shunt Resistor in Power Loop

In lower power applications, to simplify the circuit and reduce the cost, a shunt resistor can be used in series in the power loop and measure the current directly. Since the resistor is in series in the power loop, it directly measures the current and can have high accuracy by using a high precision resistor. The resistance needs to be small to reduce the power loss, and should have large enough voltage resolution for the protection. Since the sensing resistor is also in series in the gate driver loop, the voltage drop on the sensing resistor can cause the voltage drop on the gate voltage of the IGBT or SiC MOSFET modules. The parasitic inductance of the sensing resistor and the PCB trace of the sensing loop will also cause a noise voltage source during switching transient, which makes the gate voltage oscillate. Thus, this method is not recommended for high power application, or when  $di/dt$  is high. To use it in low power application, the shunt resistor loop should be designed to have the optimal voltage drop and minimum noise injection to the gate loop.

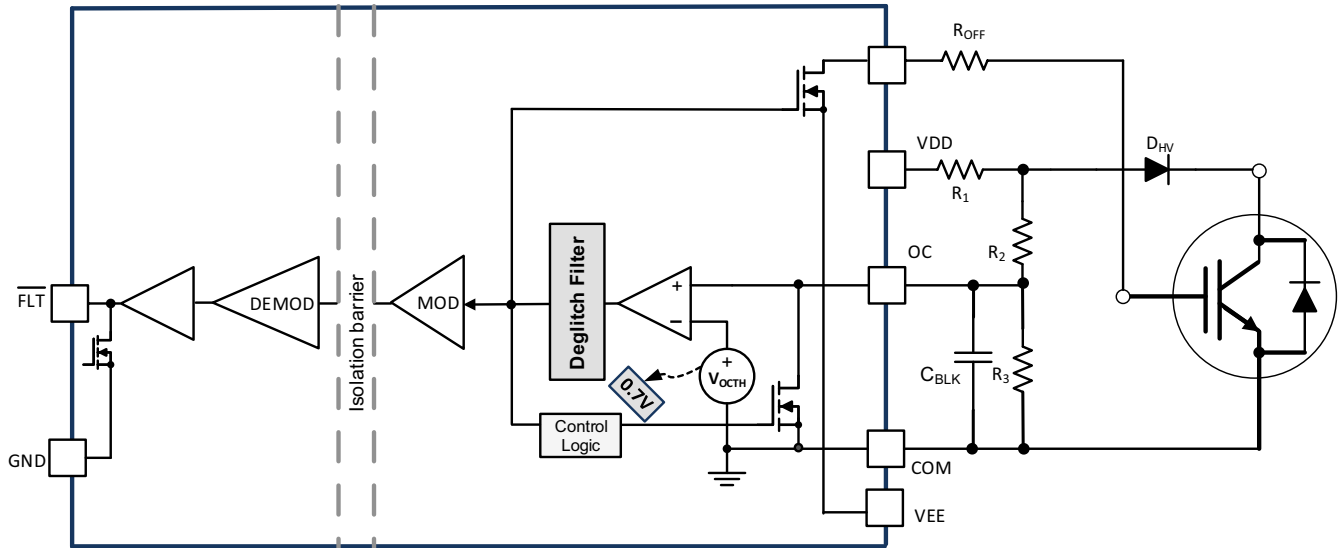

图 8-9. Overcurrent and Short Circuit Protection Based on Shunt Resistor

### 8.2.2.7 Isolated Analog Signal Sensing

The isolated analog signal sensing feature provides a simple isolated channel for the isolated temperature detection, voltage sensing and etc. One typical application of this function is the temperature monitor of the power semiconductor. Thermal diodes or temperature sensing resistors are integrated in the SiC MOSFET or IGBT module close to the dies to monitor the junction temperature. UCC21710-Q1 has an internal 200uA current source with  $\pm 3\%$  accuracy across temperature, which can forward bias the thermal diodes or create a voltage drop on the temperature sensing resistors. The sensed voltage from the AIN pin is passed through the isolation barrier to the input side and transformed to a PWM signal. The duty cycle of the PWM changes linearly from 10% to 88% when the AIN voltage changes from 4.5V to 0.6V and can be represented using 方程式 12.

$$D_{APWM}(\%) = -20 * V_{AIN} + 100 \quad (12)$$

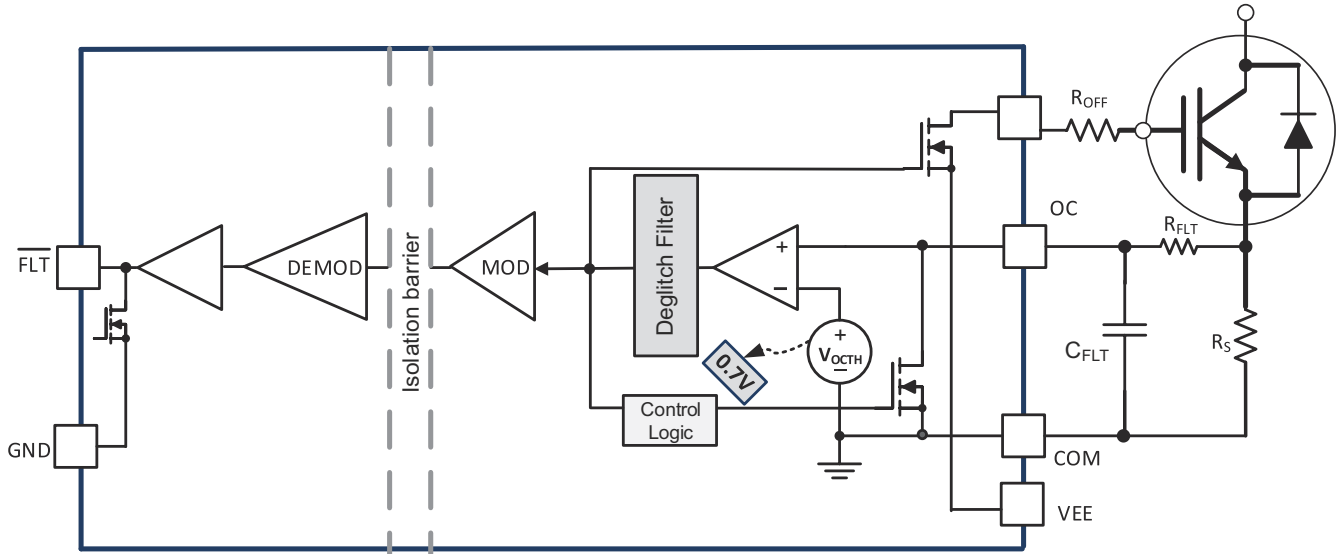
#### 8.2.2.7.1 Isolated Temperature Sensing

A typical application circuit is shown in 图 8-10. To sense temperature, the AIN pin is connected to the thermal diode or thermistor which can be discrete or integrated within the power module. A low pass filter is recommended for the AIN input. Since the temperature signal does not have a high bandwidth, the low pass filter is mainly used for filtering the noise introduced by the switching of the power device, which does not require stringent control for propagation delay. The filter capacitance for  $C_{filt}$  can be chosen between 1nF to 100nF and the filter resistance  $R_{filt}$  between  $1\Omega$  to  $10\Omega$  according to the noise level.

The output of APWM is directly connected to the microcontroller to measure the duty cycle dependent on the voltage input at AIN, using 方程式 12.



图 8-10. Thermal Diode or Thermistor Temperature Sensing Configuration

When a high-precision voltage supply for VCC is used on the primary side of UCC21710-Q1 the duty cycle output of APWM may also be filtered and the voltage measured using the microcontroller's ADC input pin, as shown in 图 8-11. The frequency of APWM is 400kHz, so the value for  $R_{\text{filt}_2}$  and  $C_{\text{filt}_2}$  should be such that the cutoff frequency is below 400kHz. Temperature does not change rapidly, thus the rise time due to the RC constant of the filter is not under a strict requirement.

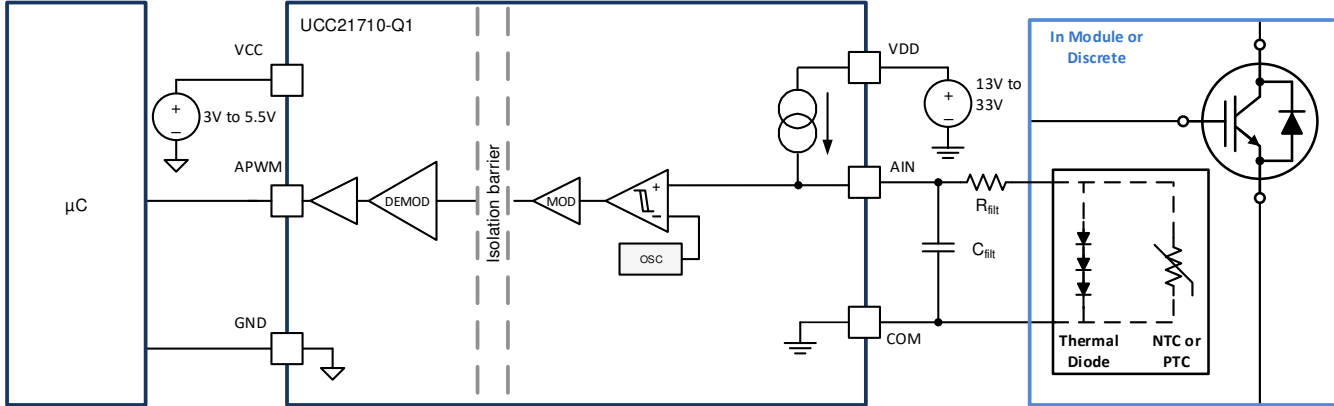

图 8-11. APWM Channel with Filtered Output

The example below shows the results using a  $4.7\text{k}\Omega$  NTC, NTCS0805E3472FMT, in series with a  $3\text{k}\Omega$  resistor and also the thermal diode using four diode-connected MMBT3904 NPN transistors. The sensed voltage of the 4 MMBT3904 thermal diodes connected in series ranges from about 2.5V to 1.6V from  $25^\circ\text{C}$  to  $135^\circ\text{C}$ , corresponding to 50% to 68% duty cycle. The sensed voltage of the NTC thermistor connected in series with the  $3\text{k}\Omega$  resistor ranges from about 1.5V to 0.6V from  $25^\circ\text{C}$  to  $135^\circ\text{C}$ , corresponding to 70% to 88% duty cycle. The voltage at VAIN of both sensors and the corresponding measured duty cycle at APWM is shown in 图 8-12.

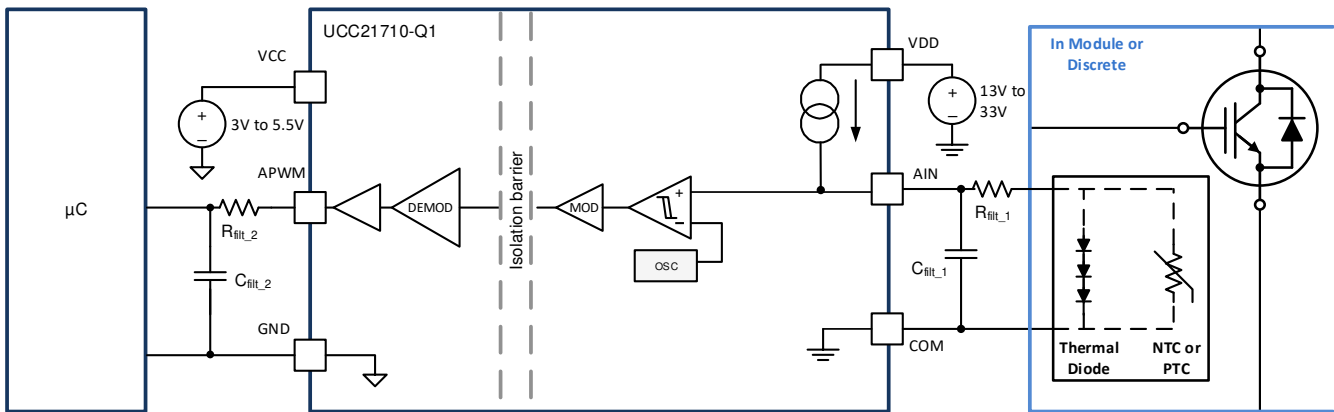

图 8-12. Thermal diode and NTC  $V_{AIN}$  and Corresponding Duty Cycle at APWM

The duty cycle output has an accuracy of  $\pm 3\%$  throughout temperature without any calibration, as shown in 图 8-13 but with single-point calibration at 25°C, the duty accuracy can be improved to  $\pm 1\%$ , as shown in 图 8-14.



图 8-13. APWM Duty Error Without Calibration

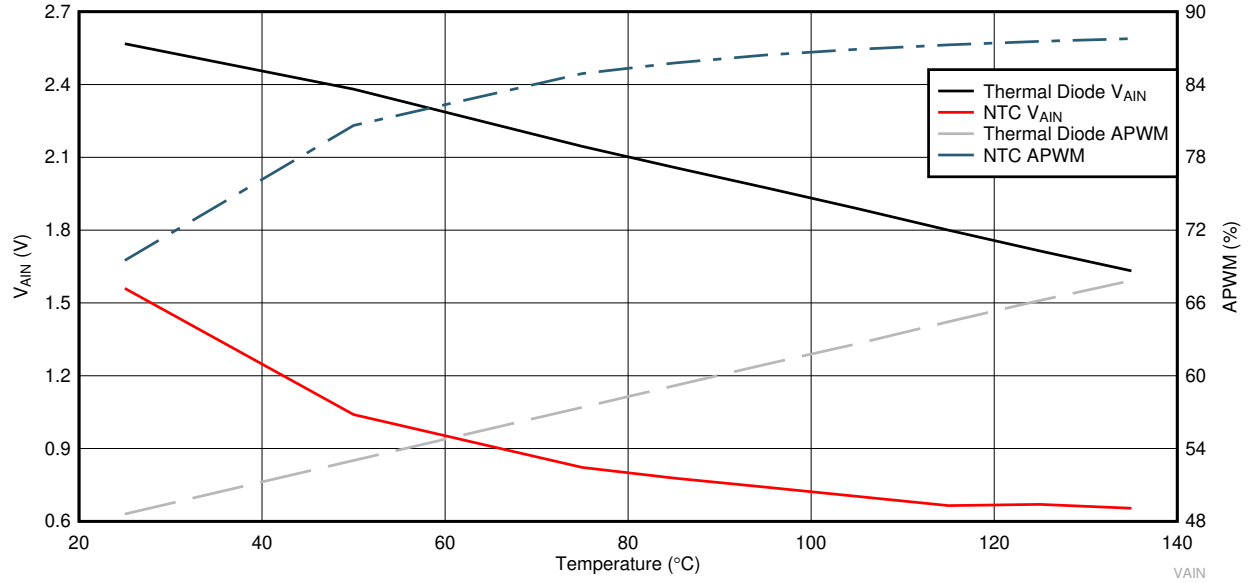

图 8-14. APWM Duty Error with Single-Point Calibration

8.2.2.7.2 Isolated DC Bus Voltage Sensing

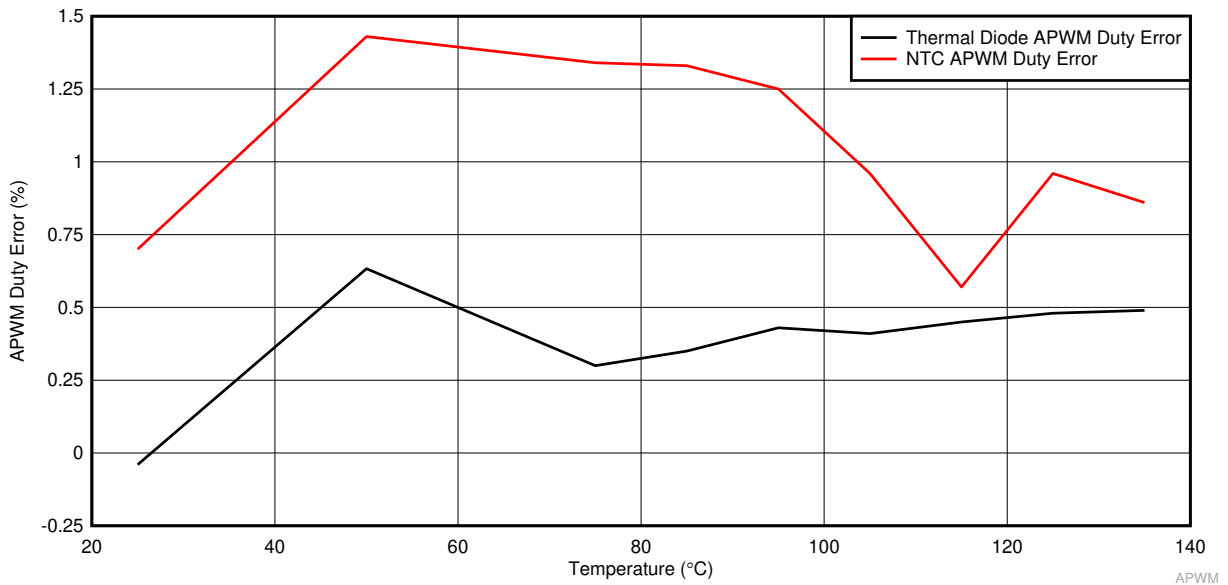
The AIN to APWM channel may be used for other applications such as the DC-link voltage sensing, as shown in 图 8-15. The same filtering requirements as given above may be used in this case, as well. The number of attenuation resistors,  $R_{atten\_1}$  through  $R_{atten\_n}$ , is dependent on the voltage level and power rating of the resistor. The voltage is finally measured across  $R_{LV\_DC}$  to monitor the stepped-down voltage of the HV DC-link which must fall within the voltage range of AIN from 0.6V to 4.5V. The driver should be referenced to the same point as the measurement reference, thus in the case shown below the UCC21710-Q1 is driving the lower IGBT in the half-bridge and the DC-link voltage measurement is referenced to COM. The internal current source  $I_{AIN}$  should be taken into account when designing the resistor divider. The AIN pin voltage is:

$$V_{AIN} = \frac{R_{LV\_DC}}{R_{LV\_DC} + \sum_{i=1}^n R_{atten\_i}} \cdot V_{DC} + R_{LV\_DC} \cdot I_{AIN} \tag{13}$$

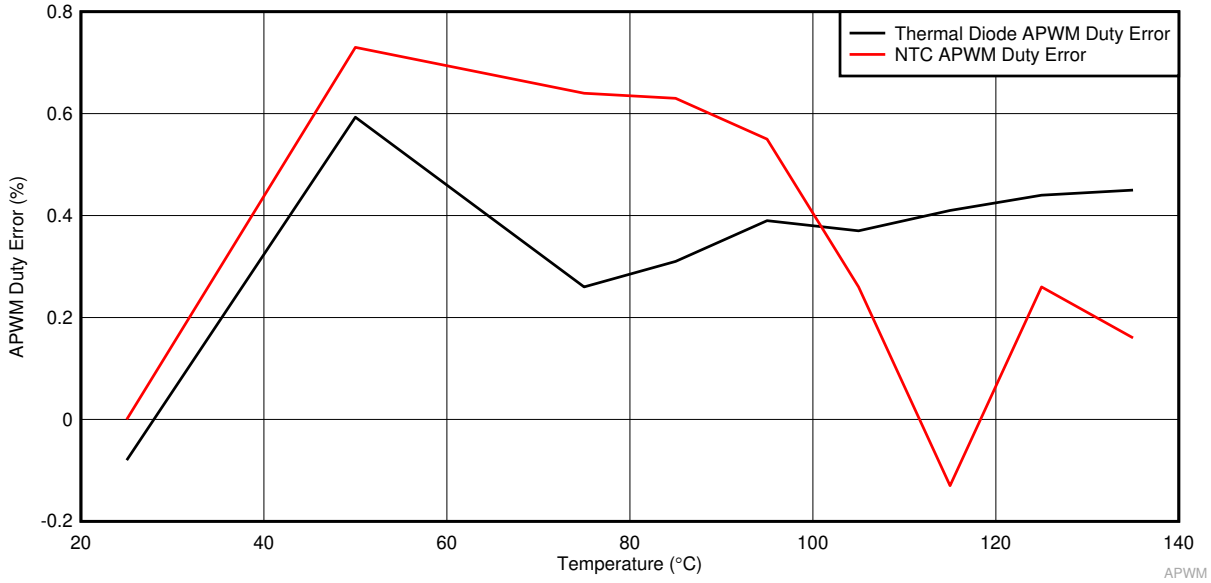

图 8-15. DC-link Voltage Sensing Configuration

### 8.2.2.8 Higher Output Current Using an External Current Buffer

To increase the IGBT gate drive current, a non-inverting current buffer (such as the NPN/PNP buffer shown in 图 8-16) can be used. Inverting types are not compatible with the desaturation fault protection circuitry and must be avoided. The MJD44H11/MJD45H11 pair is appropriate for peak currents up to 15 A, the D44VH10/ D45VH10 pair is up to 20 A peak.

In the case of a over-current detection, the soft turn off (STO) is activated. External components must be added to implement STO instead of normal turn off speed when an external buffer is used.  $C_{STO}$  sets the timing for soft turn off and  $R_{STO}$  limits the inrush current to below the current rating of the internal FET (10A).  $R_{STO}$  should be at least  $(VDD-VEE)/10$ . The soft turn off timing is determined by the internal current source of 400mA and the capacitor  $C_{STO}$ .  $C_{STO}$  is calculated using 方程式 14.

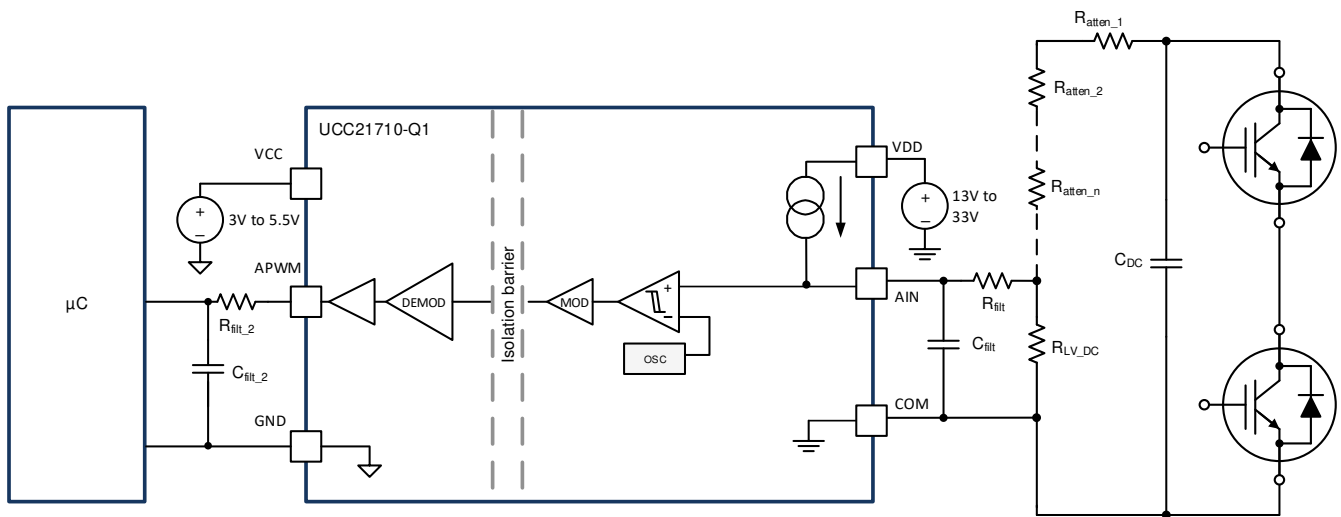
$$C_{STO} = \frac{I_{STO} \cdot t_{STO}}{VDD - VEE} \quad (14)$$

- $I_{STO}$  is the the internal STO current source, 400mA
- $t_{STO}$  is the desired STO timing



图 8-16. Current Buffer for Increased Drive Strength

## 9 Power Supply Recommendations

During the turn on and turn off switching transient, the peak source and sink current is provided by the VDD and VEE power supply. The large peak current is possible to drain the VDD and VEE voltage level and cause a voltage droop on the power supplies. To stabilize the power supply and ensure a reliable operation, a set of decoupling capacitors are recommended at the power supplies. Considering UCC21710-Q1 has  $\pm 10\text{A}$  peak drive strength and can generate high  $dV/dt$ , a  $10\mu\text{F}$  bypass cap is recommended between VDD and COM, VEE and COM. A  $1\mu\text{F}$  bypass cap is recommended between VCC and GND due to less current comparing with output side power supplies. A  $0.1\mu\text{F}$  decoupling cap is also recommended for each power supply to filter out high frequency noise. The decoupling capacitors must be low ESR and ESL to avoid high frequency noise, and should be placed as close as possible to the VCC, VDD and VEE pins to prevent noise coupling from the system parasitics of PCB layout.

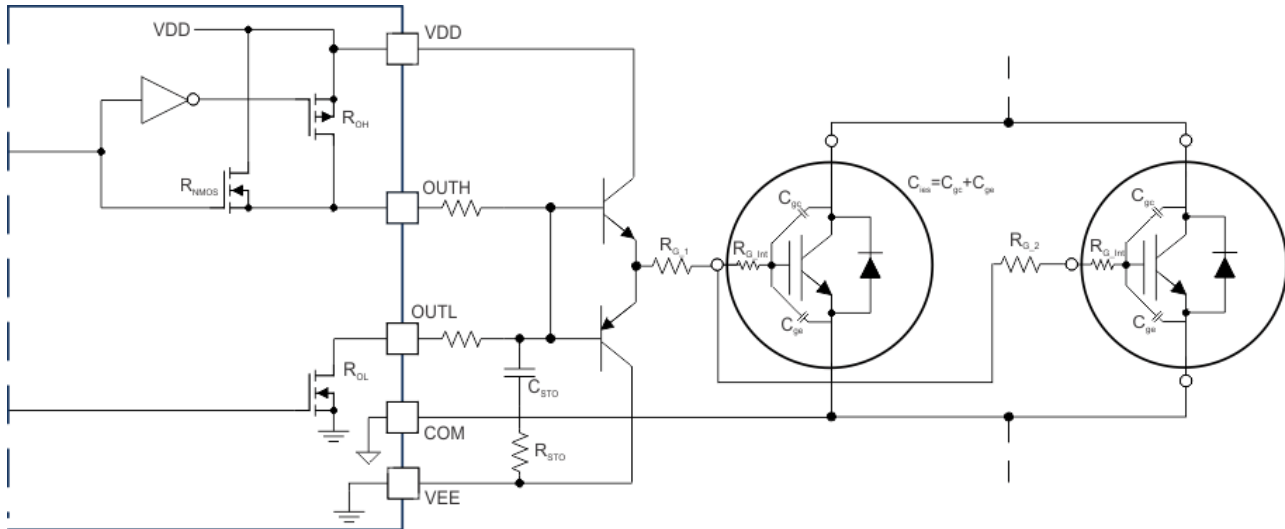

## 10 Layout

### 10.1 Layout Guidelines

Due to the strong drive strength of UCC21710-Q1, careful considerations must be taken in PCB design. Below are some key points:

- The driver should be placed as close as possible to the power semiconductor to reduce the parasitic inductance of the gate loop on the PCB traces
- The decoupling capacitors of the input and output power supplies should be placed as close as possible to the power supply pins. The peak current generated at each switching transient can cause high  $di/dt$  and voltage spike on the parasitic inductance of PCB traces
- The driver COM pin should be connected to the Kelvin connection of SiC MOSFET source or IGBT emitter. If the power device does not have a split Kelvin source or emitter, the COM pin should be connected as close as possible to the source or emitter terminal of the power device package to separate the gate loop from the high power switching loop
- Use a ground plane on the input side to shield the input signals. The input signals can be distorted by the high frequency noise generated by the output side switching transients. The ground plane provides a low-inductance filter for the return current flow
- If the gate driver is used for the low side switch which the COM pin connected to the dc bus negative, use the ground plane on the output side to shield the output signals from the noise generated by the switch node; if the gate driver is used for the high side switch, which the COM pin is connected to the switch node, ground plane is not recommended
- If ground plane is not used on the output side, separate the return path of the OC and AIN ground loop from the gate loop ground which has large peak source and sink current
- No PCB trace or copper is allowed under the gate driver. A PCB cutout is recommended to avoid any noise coupling between the input and output side which can contaminate the isolation barrier

## 10.2 Layout Example



图 10-1. Layout Example

## 11 Device and Documentation Support

### 11.1 Device Support

#### 11.1.1 第三方产品免责声明

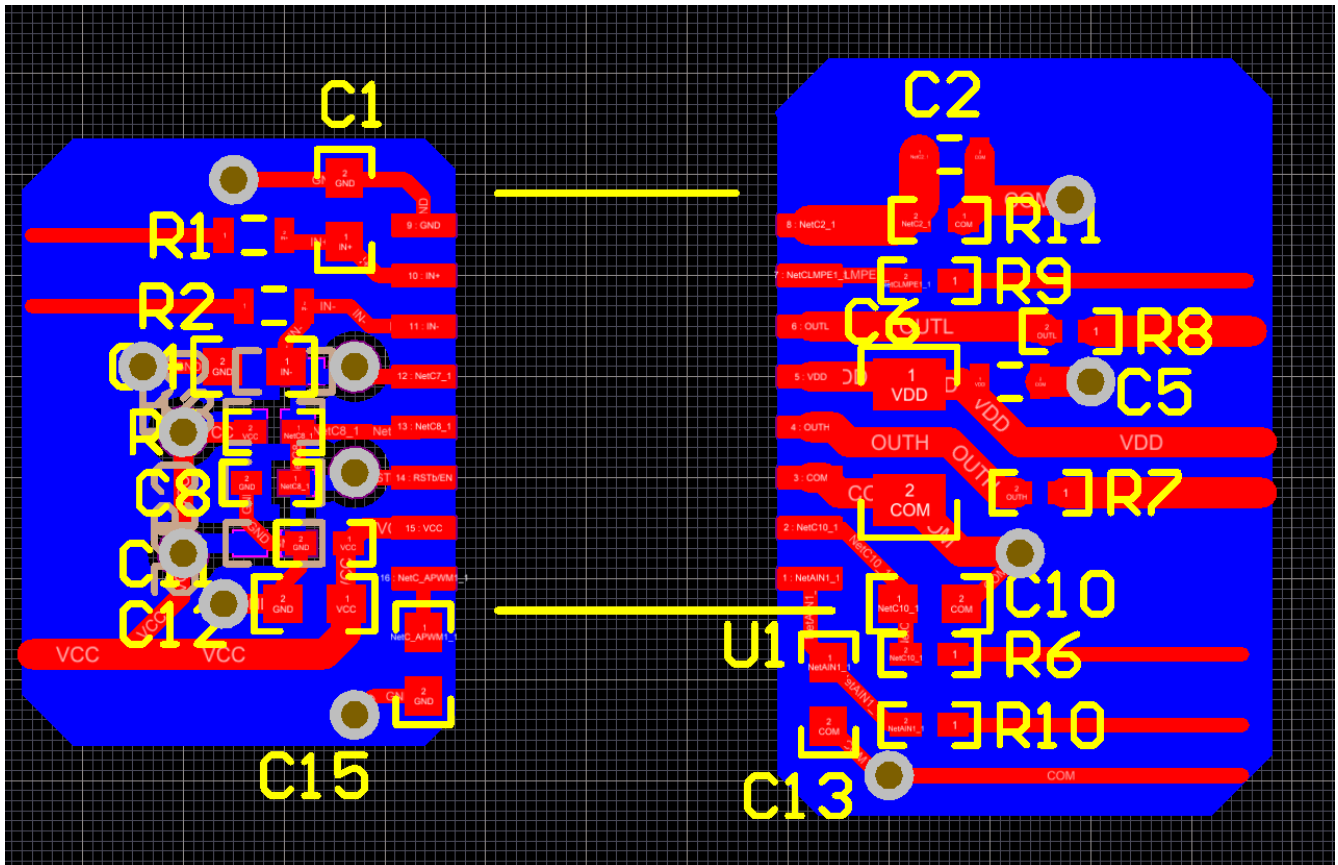
TI 发布的与第三方产品或服务有关的信息，不能构成与此类产品或服务或保修的适用性有关的认可，不能构成此类产品或服务单独或与任何 TI 产品或服务一起的表示或认可。

### 11.2 Documentation Support

#### 11.2.1 Related Documentation

For related documentation see the following:

- [Isolation Glossary](#)

### 11.3 接收文档更新通知

要接收文档更新通知，请导航至 [ti.com](#) 上的器件产品文件夹。点击 [通知](#) 进行注册，即可每周接收产品信息更改摘要。有关更改的详细信息，请查看任何已修订文档中包含的修订历史记录。

### 11.4 支持资源

[TI E2E™ 中文支持论坛](#) 是工程师的重要参考资料，可直接从专家处获得快速、经过验证的解答和设计帮助。搜索现有解答或提出自己的问题，获得所需的快速设计帮助。

链接的内容由各个贡献者“按原样”提供。这些内容并不构成 TI 技术规范，并且不一定反映 TI 的观点；请参阅 TI 的 [使用条款](#)。

### 11.5 Trademarks

TI E2E™ is a trademark of Texas Instruments.

所有商标均为其各自所有者的财产。

### 11.6 静电放电警告



静电放电 (ESD) 会损坏这个集成电路。德州仪器 (TI) 建议通过适当的预防措施处理所有集成电路。如果不遵守正确的处理和安装程序，可能会损坏集成电路。

ESD 的损坏小至导致微小的性能降级，大至整个器件故障。精密的集成电路可能更容易受到损坏，这是因为非常细微的参数更改都可能会导致器件与其发布的规格不相符。

### 11.7 术语表

[TI 术语表](#) 本术语表列出并解释了术语、首字母缩略词和定义。

## 12 Revision History

注：以前版本的页码可能与当前版本的页码不同

Changes from Revision C (May 2023) to Revision D (June 2024)	Page
• 更改了器件温度等级.....	1
• 从“特性”中删除了 ESD 分类.....	1

Changes from Revision B (December 2019) to Revision C (May 2023)	Page
• 向“特性”中添加了安全相关认证.....	1
• 向“特性”中添加了 AEC-Q100 子要点.....	1
• Added what to do with unused pins to pin functions table.....	3
• Changed recommended value of decoupling capacitors. ....	3
• Added recommended decoupling capacitor layout placement. ....	3
• Changed test conditions per DIN EN IEC 60747-17 (VDE 0884-17).....	7
• Changed certification status.....	8
• Changed V <sub>Ain</sub> lower limit to 0.6V.....	9
• Changed direction of I <sub>CLMPI</sub> in V <sub>CLP-CLMPI</sub> test condition.....	9
• Added test condition for soft turn-off current.....	9
• Deleted short circuit clamping max condition.....	9
• Change OC figure.....	29
• Added function state showing gate driver turning on. Changed RDY condition when VCC is PD. ....	32
• Changed OC figure.....	40
• Change OC figure.....	41
• Change OC figure.....	42
• Deleted tie dot from 图 8-16 .....	47

Changes from Revision A (May 2019) to Revision B (December 2019)	Page
• 将销售状态从“预告信息”更改为“量产数据” .....	1

## 13 Mechanical, Packaging, and Orderable Information

The following pages include mechanical packaging and orderable information. This information is the most current data available for the designated devices. This data is subject to change without notice and revision of this document. For browser-based versions of this data sheet, refer to the left-hand navigation.

**PACKAGING INFORMATION**

Orderable Device	Status (1)	Package Type	Package Drawing	Pins	Package Qty	Eco Plan (2)	Lead finish/ Ball material (6)	MSL Peak Temp (3)	Op Temp (°C)	Device Marking (4/5)	Samples
UCC21710QDWQ1	LIFEBUY	SOIC	DW	16	40	RoHS & Green	NIPDAU	Level-3-260C-168 HR	-40 to 125	UCC21710Q	
UCC21710QDWRQ1	ACTIVE	SOIC	DW	16	2000	RoHS & Green	NIPDAU	Level-3-260C-168 HR	-40 to 125	UCC21710Q	Samples

(1) The marketing status values are defined as follows:

**ACTIVE:** Product device recommended for new designs.

**LIFEBUY:** TI has announced that the device will be discontinued, and a lifetime-buy period is in effect.

**NRND:** Not recommended for new designs. Device is in production to support existing customers, but TI does not recommend using this part in a new design.

**PREVIEW:** Device has been announced but is not in production. Samples may or may not be available.

**OBSOLETE:** TI has discontinued the production of the device.

(2) **RoHS:** TI defines "RoHS" to mean semiconductor products that are compliant with the current EU RoHS requirements for all 10 RoHS substances, including the requirement that RoHS substance do not exceed 0.1% by weight in homogeneous materials. Where designed to be soldered at high temperatures, "RoHS" products are suitable for use in specified lead-free processes. TI may reference these types of products as "Pb-Free".

**RoHS Exempt:** TI defines "RoHS Exempt" to mean products that contain lead but are compliant with EU RoHS pursuant to a specific EU RoHS exemption.

**Green:** TI defines "Green" to mean the content of Chlorine (Cl) and Bromine (Br) based flame retardants meet JS709B low halogen requirements of <=1000ppm threshold. Antimony trioxide based flame retardants must also meet the <=1000ppm threshold requirement.

(3) MSL, Peak Temp. - The Moisture Sensitivity Level rating according to the JEDEC industry standard classifications, and peak solder temperature.

(4) There may be additional marking, which relates to the logo, the lot trace code information, or the environmental category on the device.

(5) Multiple Device Markings will be inside parentheses. Only one Device Marking contained in parentheses and separated by a "~" will appear on a device. If a line is indented then it is a continuation of the previous line and the two combined represent the entire Device Marking for that device.

(6) Lead finish/Ball material - Orderable Devices may have multiple material finish options. Finish options are separated by a vertical ruled line. Lead finish/Ball material values may wrap to two lines if the finish value exceeds the maximum column width.

**Important Information and Disclaimer:** The information provided on this page represents TI's knowledge and belief as of the date that it is provided. TI bases its knowledge and belief on information provided by third parties, and makes no representation or warranty as to the accuracy of such information. Efforts are underway to better integrate information from third parties. TI has taken and continues to take reasonable steps to provide representative and accurate information but may not have conducted destructive testing or chemical analysis on incoming materials and chemicals. TI and TI suppliers consider certain information to be proprietary, and thus CAS numbers and other limited information may not be available for release.

In no event shall TI's liability arising out of such information exceed the total purchase price of the TI part(s) at issue in this document sold by TI to Customer on an annual basis.

**OTHER QUALIFIED VERSIONS OF UCC21710-Q1 :**

- Catalog : [UCC21710](#)

## NOTE: Qualified Version Definitions:

- Catalog - TI's standard catalog product

**TAPE AND REEL INFORMATION**

**QUADRANT ASSIGNMENTS FOR PIN 1 ORIENTATION IN TAPE**

\*All dimensions are nominal

Device	Package Type	Package Drawing	Pins	SPQ	Reel Diameter (mm)	Reel Width W1 (mm)	A0 (mm)	B0 (mm)	K0 (mm)	P1 (mm)	W (mm)	Pin1 Quadrant
UCC21710QDWRQ1	SOIC	DW	16	2000	330.0	16.4	10.75	10.7	2.7	12.0	16.0	Q1

**TAPE AND REEL BOX DIMENSIONS**

\*All dimensions are nominal

Device	Package Type	Package Drawing	Pins	SPQ	Length (mm)	Width (mm)	Height (mm)
UCC21710QDWRQ1	SOIC	DW	16	2000	356.0	356.0	35.0



**TUBE**

\*All dimensions are nominal

Device	Package Name	Package Type	Pins	SPQ	L (mm)	W (mm)	T (μm)	B (mm)
UCC21710QDWQ1	DW	SOIC	16	40	506.98	12.7	4826	6.6

## GENERIC PACKAGE VIEW

**DW 16**

**SOIC - 2.65 mm max height**

7.5 x 10.3, 1.27 mm pitch

SMALL OUTLINE INTEGRATED CIRCUIT

This image is a representation of the package family, actual package may vary.  
Refer to the product data sheet for package details.



4224780/A



# DW0016B

# PACKAGE OUTLINE

## SOIC - 2.65 mm max height

SOIC

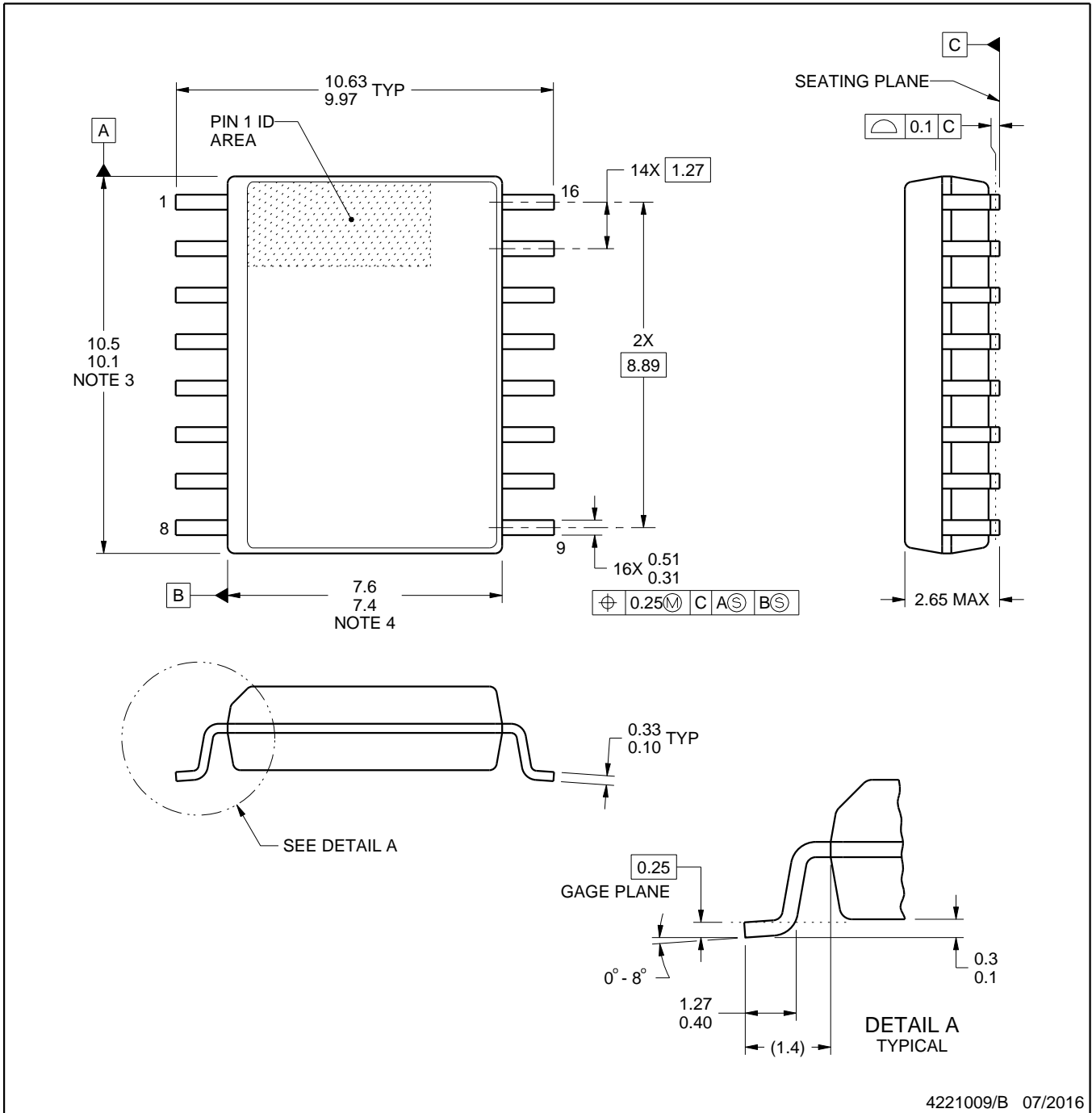

4221009/B 07/2016

# EXAMPLE BOARD LAYOUT

DW0016B

SOIC - 2.65 mm max height

SOIC



LAND PATTERN EXAMPLE  
SCALE:4X



SOLDER MASK DETAILS

4221009/B 07/2016

NOTES: (continued)

- 6. Publication IPC-7351 may have alternate designs.
- 7. Solder mask tolerances between and around signal pads can vary based on board fabrication site.

# EXAMPLE STENCIL DESIGN

DW0016B

SOIC - 2.65 mm max height

SOIC

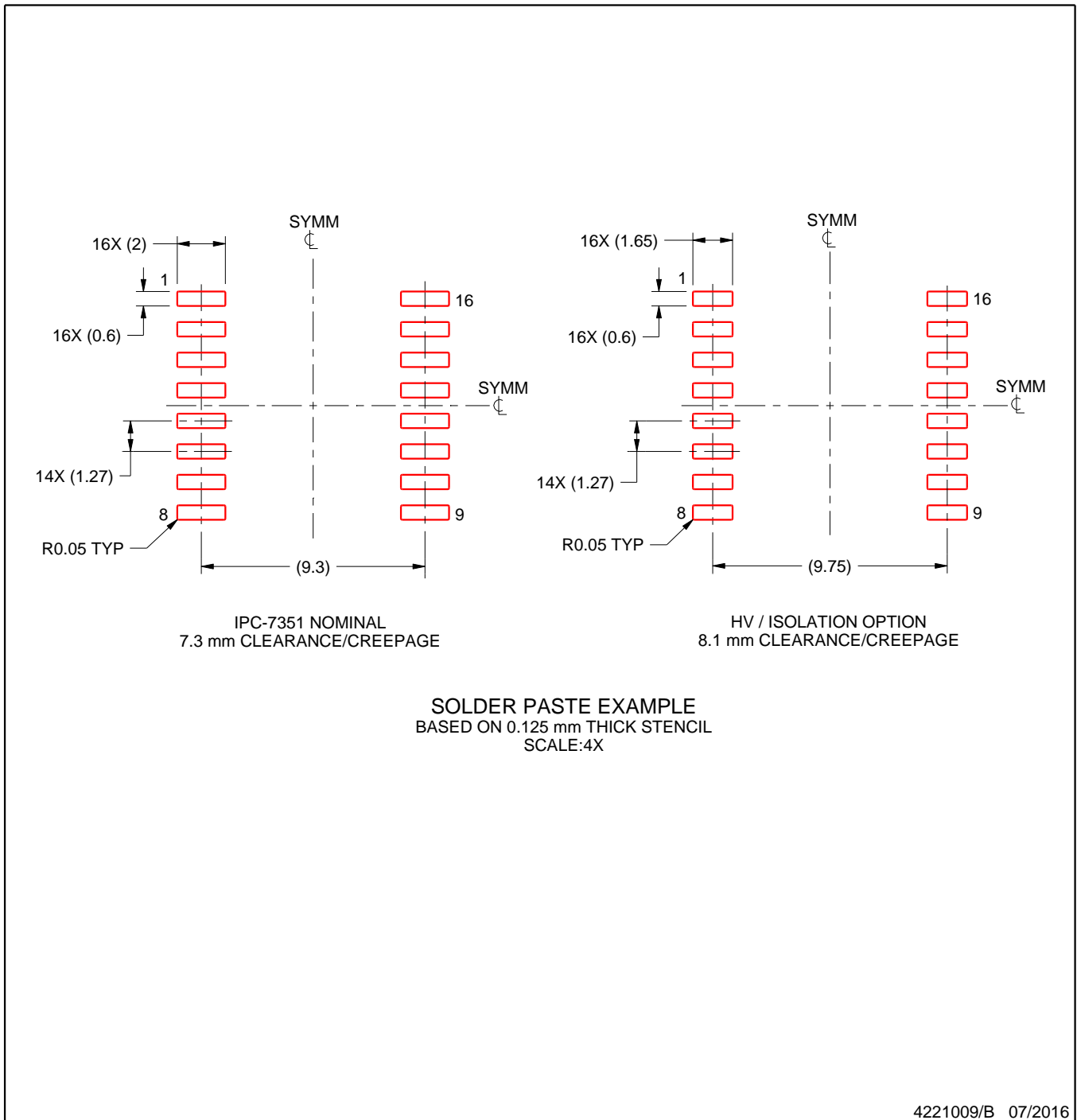

NOTES: (continued)

8. Laser cutting apertures with trapezoidal walls and rounded corners may offer better paste release. IPC-7525 may have alternate design recommendations.
9. Board assembly site may have different recommendations for stencil design.

## 重要声明和免责声明

TI“按原样”提供技术和可靠性数据（包括数据表）、设计资源（包括参考设计）、应用或其他设计建议、网络工具、安全信息和其他资源，不保证没有瑕疵且不做任何明示或暗示的担保，包括但不限于对适销性、某特定用途方面的适用性或不侵犯任何第三方知识产权的暗示担保。

这些资源可供使用 TI 产品进行设计的熟练开发人员使用。您将自行承担以下全部责任：(1) 针对您的应用选择合适的 TI 产品，(2) 设计、验证并测试您的应用，(3) 确保您的应用满足相应标准以及任何其他功能安全、信息安全、监管或其他要求。

这些资源如有变更，恕不另行通知。TI 授权您仅可将这些资源用于研发本资源所述的 TI 产品的应用。严禁对这些资源进行其他复制或展示。您无权使用任何其他 TI 知识产权或任何第三方知识产权。您应全额赔偿因在这些资源的使用中对 TI 及其代表造成的任何索赔、损害、成本、损失和债务，TI 对此概不负责。

TI 提供的产品受 [TI 的销售条款](#) 或 [ti.com](#) 上其他适用条款/TI 产品随附的其他适用条款的约束。TI 提供这些资源并不会扩展或以其他方式更改 TI 针对 TI 产品发布的适用的担保或担保免责声明。

TI 反对并拒绝您可能提出的任何其他或不同的条款。

邮寄地址：Texas Instruments, Post Office Box 655303, Dallas, Texas 75265

Copyright © 2024，德州仪器 (TI) 公司