

UCC27611 5V、4A 至 6A 低侧 GaN 驱动器

1 特性

- 增强模式氮化镓场效应晶体管 (FET) (eGANFET)
- 4V 到 18V 单电源供电电压范围
- 5V 的驱动电压 VREF
- 4A 峰值拉电流和 6A 峰值灌电流驱动
- 1Ω 和 0.35Ω 上拉和下拉电阻 (最大限度提升对高转换率 dV 和 dt 的抗扰度)
- 分离输出配置 (可实现针对各个 FET 的导通和关断优化)
- 传输延迟小 (典型值为 14ns)
- 快速上升和下降时间 (典型值分别为 9ns 和 5ns)
- TTL 和 CMOS 兼容输入 (不受电源电压影响, 很容易连接至数字和模拟控制器)
- 双输入设计实现了灵活驱动 (反相配置和同相配置均受支持)
- 当输入悬空时输出保持在低电平
- VDD 欠压锁定 (UVLO)
- 采用与 eGANFET 兼容的优化引脚分布, 方便进行布局布线
- 具有外露散热焊盘和接地焊盘的 2.00mm × 2.00mm 小外形尺寸无引线 (SON)-6 封装 (最大限度降低寄生电感以减少栅极振铃)
- 工作温度范围: -40°C 至 140°C

2 应用

- 开关电源供电
- 直流 - 直流转换器
- 同步整流
- 太阳能逆变器、电机控制、不间断电源 (UPS)
- 包络跟踪电源

3 说明

UCC27611 是一款针对 5V 驱动而进行优化的单通道、高速、栅极驱动器, 它专门用来对增强模式 GaN FET 进行寻址。驱动电压 VREF 被内部线性稳压器精确稳压至 5V。UCC27611 提供 4A 拉电流和 6A 灌电流的非对称轨到轨峰值电流驱动能力。凭借分离输出配置, 可根据 FET 优化其导通和关断时间。具有最低寄生电感的封装和引脚分配减少了上升和下降时间并限制了振铃。此外, 具有最小容差和变化的短传播延迟可实现高频时的有效运行。1Ω 和 0.35Ω 电阻提升了针对高转换率 dV 和 dt 所致硬开关的抗扰度。

不受 VDD 输入信号阈值的影响确保了 TTL 和 CMOS 低压逻辑兼容性。出于安全方面的考虑, 当输入引脚处于悬空状态时, 内部输出上拉和下拉电阻将输出保持在低电平。VREF 引脚上的内部电路具有欠压锁定功能, 可在 VREF 电源电压处于工作范围之内之前, 将输出保持在低电平。UCC27611 采用具有外部散热焊盘和接地焊盘的小型 2.00mm × 2.00mm SON-6 封装 (DRV), 提升了封装功率处理能力。UCC27611 运行在 -40°C 至 140°C 的宽温度范围内。

器件信息(1)

器件型号	封装	封装尺寸 (标称值)
UCC27611	SON (6)	2.00mm × 2.00mm

(1) 如需了解所有可用封装, 请参阅数据表末尾的可订购产品附录。

典型应用图

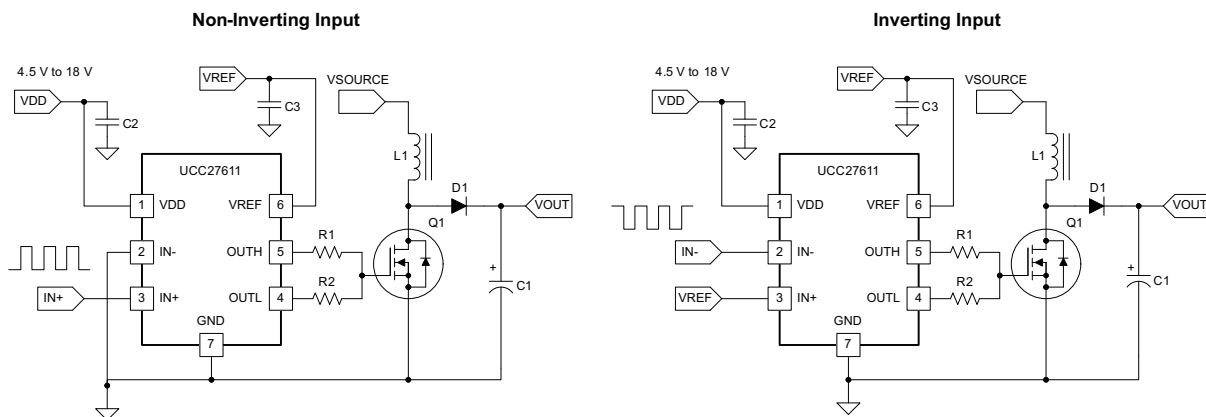

目录

1 特性	1	7.4 Device Functional Modes	11
2 应用	1	8 Application and Implementation	12
3 说明	1	8.1 Application Information	12
4 修订历史记录	2	8.2 Typical Application	13
5 Pin Configuration and Functions	3	9 Power Supply Recommendations	18
6 Specifications	3	10 Layout	20
6.1 Absolute Maximum Ratings	3	10.1 Layout Guidelines	20
6.2 ESD Ratings	4	10.2 Layout Example	20
6.3 Recommended Operating Conditions	4	11 器件和文档支持	21
6.4 Thermal Information	4	11.1 文档支持	21
6.5 Electrical Characteristics	5	11.2 接收文档更新通知	21
6.6 Switching Characteristics	5	11.3 社区资源	21
6.7 Typical Characteristics	7	11.4 商标	21
7 Detailed Description	8	11.5 静电放电警告	21
7.1 Overview	8	11.6 Glossary	21
7.2 Functional Block Diagram	8	12 机械、封装和可订购信息	21
7.3 Feature Description	8		

4 修订历史记录

注：之前版本的页码可能与当前版本有所不同。

Changes from Revision E (February 2018) to Revision F	Page
• Changed <i>Power Up (Noninverting Drive)</i> graphic	9
• Changed <i>Power Up (Inverting Drive)</i> graphic	9

Changes from Revision D (October 2017) to Revision E	Page
• 已更改 标题	1

Changes from Revision C (December 2015) to Revision D	Page
• 已更改 标题	1

Changes from Revision B (May 2013) to Revision C	Page
• 已添加 <i>ESD</i> 额定值表，特性 说明部分、器件功能模式、应用和实施部分、电源相关建议部分，布局部分、器件和文档支持部分以及机械、封装和可订购信息部分	1

Changes from Revision A (December 2012) to Revision B	Page
• Added <i>Electrical Characteristics</i> Inputs (IN+, IN-) section values	5

5 Pin Configuration and Functions

DRV Package
6-Pin SON With Exposed Thermal Pad
Top View

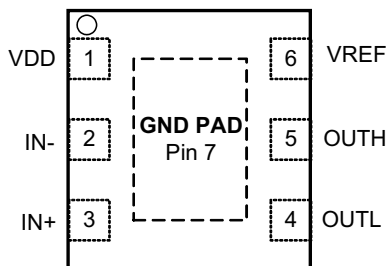

Pin Functions

PIN		I/O	DESCRIPTION
NO.	NAME		
1	VDD	I	Bias supply input. Connect a ceramic capacitor minimum from this pin to the GND pin as close as possible to the device with the shortest trace lengths possible.
2	IN-	I	Inverting input. Pull IN+ to VDD to enable output, when using the driver device in Inverting configuration.
3	IN+	I	Noninverting input. Pull IN- to GND to enable output, when using the driver device in noninverting configuration.
4	OUTL	O	6-A sink current output of driver.
5	OUTH	O	4-A source current output of driver.
6	VREF	O	Drive voltage, output of internal linear regulator. Connect a ceramic capacitor minimum from this pin to the GND pin as close as possible to the device with the shortest trace lengths possible.
7	GND PAD	—	Ground. All signals are referenced to this node.

6 Specifications

6.1 Absolute Maximum Ratings

over operating free-air temperature range (unless otherwise noted)⁽¹⁾

		MIN	MAX	UNIT
V _{DD}	Supply voltage	-0.3	20	V
	OUTH	-0.3	VREF + 0.3	V
	OUTL	-0.3	VREF + 0.3	V
	VREF		6	V
	IN+, IN-	-0.3	20	V
I _{out_DC}	Continuous source current of OUTH/sink current of OUTL	0.3	0.6	A
I _{out_pulsed}	Continuous source current of OUTH/sink current of OUTL (0.5 μs),	4	6	A
	Lead temperature, soldering, 10 sec.		300	°C
	Lead temperature, reflow		260	°C
T _J	Operating virtual junction temperature	-40	150	°C
T _{stg}	Storage temperature	-65	150	°C

- (1) Stresses beyond those listed under *Absolute Maximum Ratings* may cause permanent damage to the device. These are stress ratings only, which do not imply functional operation of the device at these or any other conditions beyond those indicated under *Recommended Operating Conditions*. Exposure to absolute-maximum-rated conditions for extended periods may affect device reliability.

6.2 ESD Ratings

		VALUE	UNIT
$V_{(ESD)}$ Electrostatic discharge	Human-body model (HBM), per ANSI/ESDA/JEDEC JS-001 ⁽¹⁾	±2000	V
	Charged-device model (CDM), per JEDEC specification JESD22-C101 ⁽²⁾	±500	

(1) JEDEC document JEP155 states that 500-V HBM allows safe manufacturing with a standard ESD control process.

(2) JEDEC document JEP157 states that 250-V CDM allows safe manufacturing with a standard ESD control process.

6.3 Recommended Operating Conditions

over operating free-air temperature range (unless otherwise noted)

		MIN	NOM	MAX	UNIT
VDD	Supply voltage	4	12	18	V
IN	Input voltage	0		18	V
	IN+, IN– resistance			100	kΩ
T_J	Operating junction temperature	–40		140	°C

6.4 Thermal Information

THERMAL METRIC ⁽¹⁾		UCC27611	UNIT
		DRV (SON)	
		6 PINS	
$R_{\theta JA}$	Junction-to-ambient thermal resistance	80.3	°C/W
$R_{\theta JC(top)}$	Junction-to-case (top) thermal resistance	11.9	°C/W
$R_{\theta JB}$	Junction-to-board thermal resistance	49.7	°C/W
ψ_{JT}	Junction-to-top characterization parameter	5.5	°C/W
ψ_{JB}	Junction-to-board characterization parameter	50.1	°C/W
$R_{\theta JC(bot)}$	Junction-to-case (bottom) thermal resistance	18.8	°C/W

(1) For more information about traditional and new thermal metrics, see the [Semiconductor and IC Package Thermal Metrics](#) application report.

6.5 Electrical Characteristics

VDD = 12 V, TA = TJ = –40 °C to 140 °C, 2-μF capacitor from VDD to GND and from VREF to GND. Currents are positive into, negative out of the specified terminal. OUTH and OUTL are tied together. (unless otherwise noted) ⁽¹⁾

PARAMETER		TEST CONDITIONS	MIN	TYP	MAX	UNIT
BIAS CURRENT						
IDD(off)	Start-up current	VDD = 3, IN+ = VDD, IN– = GND		100	180	μA
		IN+ = GND, IN– = VDD		75	160	
UNDER VOLTAGE LOCKOUT (UVLO)						
VDD(on)	Supply start threshold		3.55	3.8	4.15	V
VDD(off)	Minimum operating voltage after supply start		3.3	3.55	3.9	V
VDD_H	Supply voltage hysteresis			0.25		V
INPUTS (IN+, IN–)						
VIN_L	Input signal low threshold	Output high for IN– pin, Output Low for IN+ pin	0.9	1.1	1.3	V
VIN_H	Input signal high threshold	Output high for IN+ pin, Output low for IN– pin	1.85	2.05	2.25	V
VIN_HYS	Input signal hysteresis		0.7	0.95	1.2	V
VREF						
VREF	VREF regulator output		4.75	5	5.15	V
VREF_line	VREF line regulation	VDD from 6 V to 18 V			0.05	V
VREF_load	VREF load regulation	IR from 0 mA to 50 mA			0.075	V
ISCC	Short circuit current		–90	–75	–60	mA
OUTPUTS (OUTH/OUTL AND OUT)						
ISRC/SNK	Source peak current (OUTH) / sink peak current (OUTL) ⁽²⁾	CLOAD = 0.22 μF, FSW = 1 kHz, ⁽²⁾		–4/+6		A
VOH	OUTH high voltage	IOUTH = –10 mA	VDD –0.05			V
VOL	OUTL low voltage	IOUTL = 10 mA			0.02	V
ROH	OUTH pullup resistance	TA = 25 °C, IOUT = –25 mA to –50 mA		1		Ω
		TA = –40 °C to 140 °C, IOUT = –50 mA			2	
ROL	OUTH pulldown resistance	TA = 25 °C, IOUT = 25 mA to 50 mA		0.35		Ω
		TA = –40 °C to 140 °C, IOUT = 50 mA			1.5	

(1) Device operational with output switching.

(2) Ensured by design, not tested in production.

6.6 Switching Characteristics

over operating free-air temperature range (unless otherwise noted)

PARAMETER		TEST CONDITIONS	MIN	TYP	MAX	UNIT
tR	Rise time ⁽¹⁾	CLOAD = 1 nF		5		ns
tF	Fall time ⁽¹⁾	CLOAD = 1 nF		5		ns
tD1	Turnon propagation delay ⁽¹⁾	CLOAD = 1 nF, IN = 0 V to 5 V		14	25	ns
tD2	Turnoff propagation delay ⁽¹⁾	CLOAD = 1 nF, IN = 5 V to 0 V		14	25	ns

(1) See [Figure 1](#) and [Figure 2](#) timing diagrams.

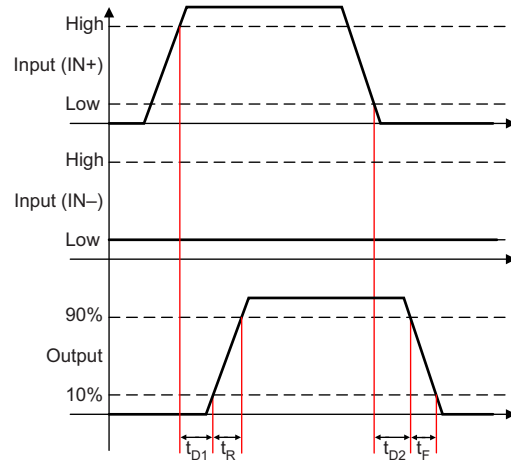

**Figure 1. Noninverting Configuration
(OUTH and OUTL Are Tied Together)**

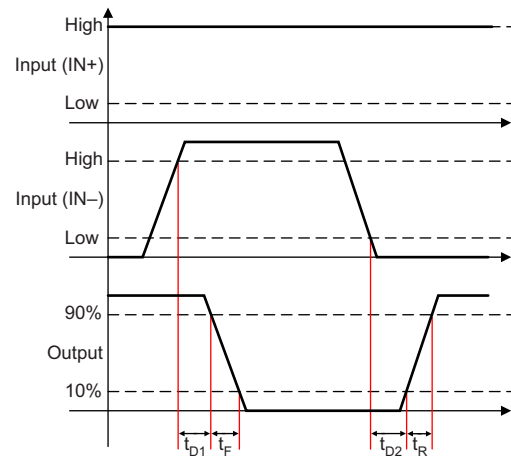

**Figure 2. Inverting Configuration
(OUTH and OUTL Are Tied Together)**

6.7 Typical Characteristics

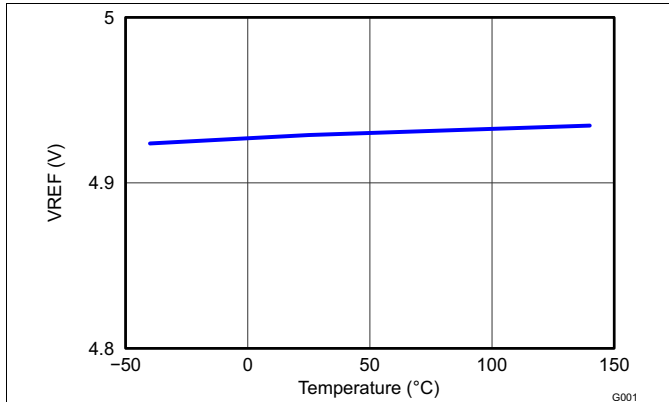

Figure 3. Reference Voltage vs Temperature

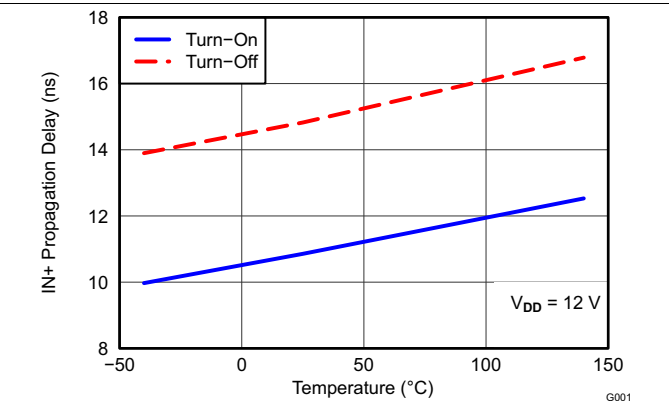

Figure 4. IN+ Propagation Delay

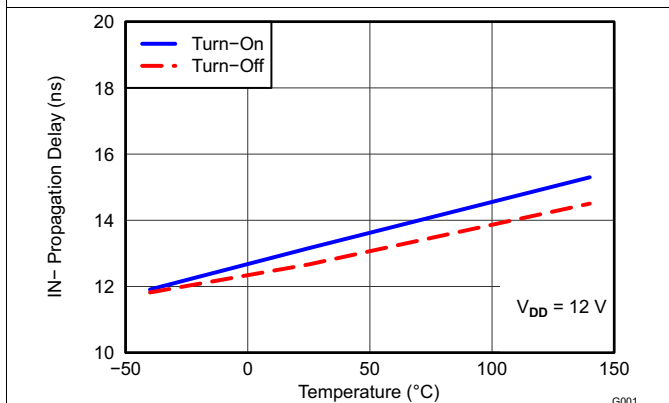

Figure 5. IN- Propagation Delay

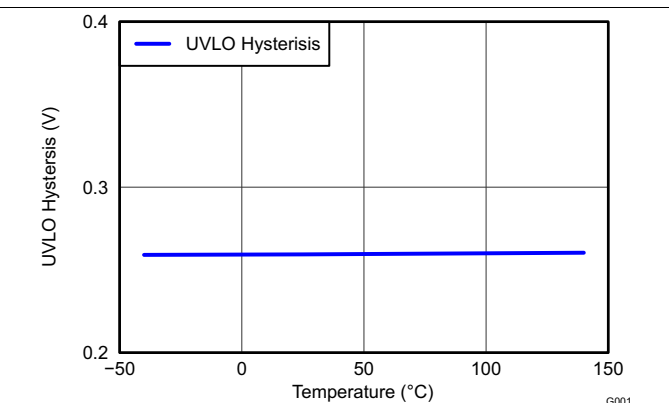

Figure 6. UVLO Hysteresis

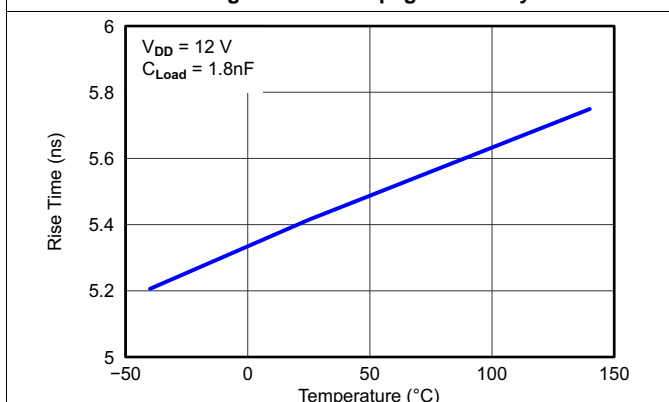

Figure 7. Rise Time

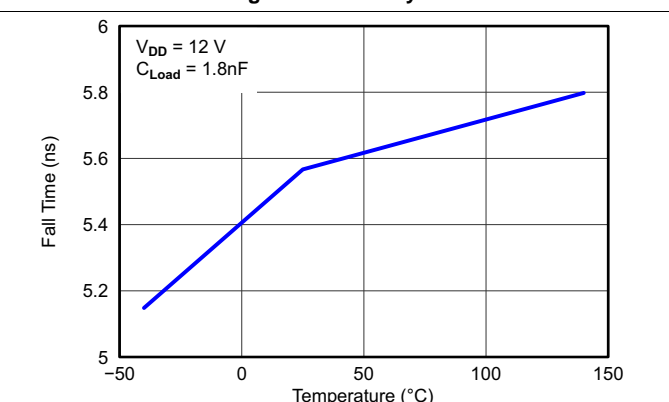

Figure 8. Fall Time

7 Detailed Description

7.1 Overview

The UCC27611 is a single-channel, high-speed, gate driver capable of effectively driving MOSFET power switches (specifically addressing enhancement mode GaN FETs) by up to 4-A source and 6-A sink peak current. Strong sink capability in asymmetrical drive boosts immunity against parasitic Miller turnon effect. The drive voltage V_{REF} is precisely regulated by internal linear regulator to 5 V, which is optimized for driving enhancement mode GaN FET. The input threshold of UCC27611 is based on TTL and CMOS compatible low-voltage logic, which is fixed and independent of VDD supply voltage. The 0.95-V typical hysteresis offers excellent noise immunity. For safety reason, when the input pins are in a floating condition, the internal input pullup and pulldown resistors hold the output LOW. The device also features a split-output configuration, where the gate-drive current is sourced through the OUTH pin and sunk through the OUTL pin. This pin arrangement allows the user to apply independent turnon and turnoff resistors to the OUTH and OUTL pins, respectively, and easily control the switching slew rates. The driver has rail-to-rail drive capability and extremely small propagation delay, with minimized tolerances and variations. Package and pinout with minimum parasitic inductances reduce the rise and fall time, and limit the ringing allows efficient operation at high frequencies.

7.2 Functional Block Diagram

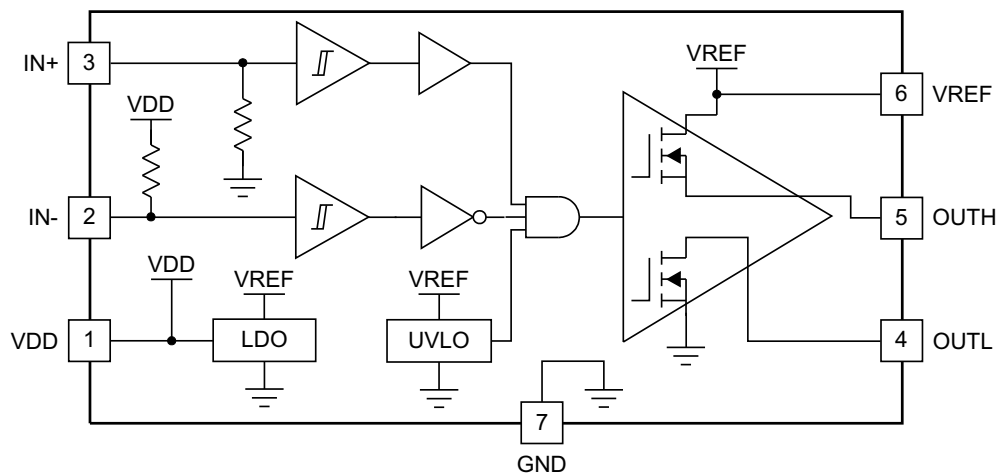

7.3 Feature Description

7.3.1 VDD and Undervoltage Lockout

The UCC27611 device has internal Under Voltage LockOut (UVLO) protection feature on the VDD pin supply circuit blocks. Whenever the driver is in UVLO condition (that is when VDD voltage less than $V_{DD(on)}$ during power up, and when VDD voltage is less than $V_{DD(off)}$ during power down), this circuit holds all outputs LOW, regardless of the status of the inputs. The UVLO is typically 3.8 V, with 250-mV typical hysteresis. This hysteresis helps prevent chatter when low VDD supply voltages have noise from the power supply, and also when there are droops in the VDD bias voltage when the system commences switching and there is a sudden increase in I_{DD} . The capability to operate at low-voltage levels such as below 5 V, along with best-in-class switching characteristics, is especially suited for driving emerging GaN wide bandgap power semiconductor devices.

For example, at power up, the UCC27611 driver output remains LOW until the VDD voltage reaches the UVLO threshold. The magnitude of the OUT signal rises with VDD, until steady-state VDD is reached. In the noninverting operation (PWM signal applied to IN+ pin), see [Figure 9](#), the output remains LOW until the UVLO threshold is reached, and then the output is in-phase with the input. In the inverting operation (PWM signal applied to IN- pin), see [Figure 10](#), the output remains LOW until the UVLO threshold is reached, and then the output is out-phase with the input. In both cases, the unused input pin must be properly biased to enable the output.

Feature Description (continued)

NOTE

The output turns to high state only if IN+ pin is high and IN- pin is low after the UVLO threshold is reached.

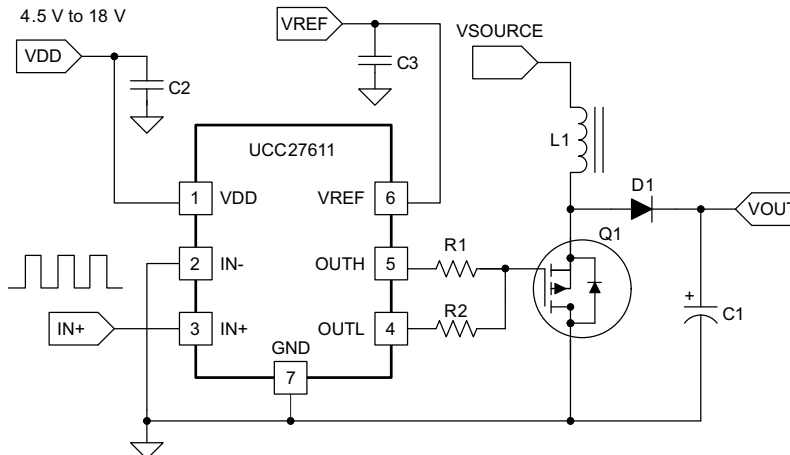

Figure 9. Power Up (Noninverting Drive)

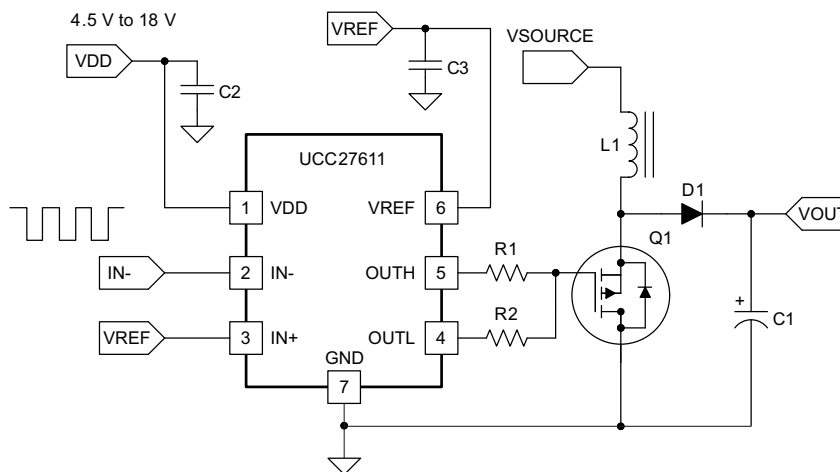

Figure 10. Power Up (Inverting Drive)

7.3.2 Operating Supply Current

The UCC27611 device features very low quiescent I_{DD} current. The total supply current is the sum of the quiescent I_{DD} current, the average I_{OUT} current due to switching, and finally any current related to pullup resistors on the unused input pin. For example, when the inverting input pin is pulled low, additional current is drawn from VDD supply through the pullup resistors (see [Functional Block Diagram](#)). Knowing the operating frequency (f_{SW}) and the MOSFET gate (Q_G) charge at the drive voltage being used, the average I_{OUT} current can be calculated as product of Q_G and f_{SW} .

Feature Description (continued)

7.3.3 Input Stage

The input pins of the UCC27611 device is based on a TTL and CMOS compatible input threshold logic that is independent of the VDD supply voltage. With typical high threshold = 2.05 V and typical low threshold = 1.1 V, the logic level thresholds can be conveniently driven with PWM control signals derived from 3.3-V and 5-V digital power controllers. Wider hysteresis (typical 1 V) offers enhanced noise immunity compared to traditional TTL logic implementations, where the hysteresis is typically less than 0.5 V. These devices also feature tight control of the input pin threshold voltage levels, which eases system design considerations, and ensures stable operation across temperature. The very low input capacitance on these pins reduces loading, and increases switching speed.

The device features an important safety function wherein, whenever any of the input pins are in a floating condition, the output of the respective channel is held in the low state. This is achieved using VDD pullup resistors on all the inverting inputs (IN⁻ pin), or GND pulldown resistors on all the noninverting input pins (IN⁺ pin)(see [Functional Block Diagram](#)).

The device also features a dual input configuration, with two input pins available to control the state of the output. The user has the flexibility to drive the device using either a noninverting input pin (IN⁺), or an inverting input pin (IN⁻). The state of the output pin is dependent on the bias of both the IN⁺ and IN⁻ pins. See [Table 1](#) input and output logic truth table, and the [Figure 12](#) for additional clarification.

7.3.4 Enable Function

An enable and disable function can be easily implemented in the UCC27611 device using the unused input pin. When IN⁺ is pulled down to GND, or IN⁻ is pulled down to VDD, the output is disabled. Thus, IN⁺ pin can be used like an enable pin that is based on active high logic, while IN⁻ can be used like an enable pin that is based on active low logic.

7.3.5 Output Stage

The output stage of the UCC27611 device is illustrated in [Figure 11](#). OUTH and OUTL are externally connected and pinned out as OUTH and OUTL pins. The UCC27611 device features a unique architecture on the output stage, which delivers the highest peak source current when it is most needed during the Miller plateau region of the power switch turnon transition (when the power switch drain and collector voltage experiences dV and dt). The device output stage features a hybrid pullup structure using a parallel arrangement of N-channel and P-channel MOSFET devices. By turning on the N-channel MOSFET, during a narrow instant when the output changes state from low to high, the gate-driver device is able to deliver a brief boost in the peak-sourcing current, enabling fast turnon.

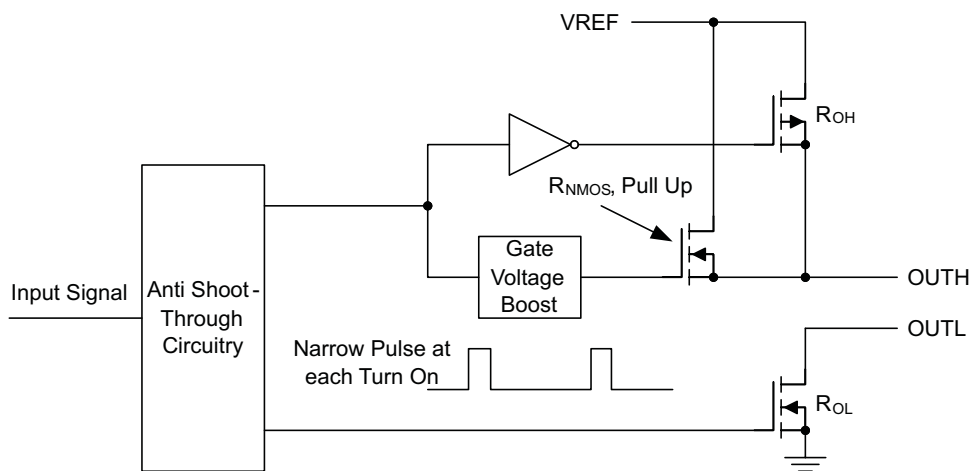

Figure 11. UCC27611 Device Gate Driver Output Structure

Feature Description (continued)

The R_{OH} parameter (see [Electrical Characteristics](#)) is a DC measurement, and it is representative of the on-resistance of the P-channel device only, because the N-channel device is turned on only during output change of state from low to high. Thus, the effective resistance of the hybrid pullup stage is much lower than what is represented by R_{OH} parameter. The pulldown structure is composed of a N-channel MOSFET only. The R_{OL} parameter (see [Electrical Characteristics](#)), which is also a DC measurement, is representative of true impedance of the pulldown stage in the device.

The driver output voltage swings between VDD and GND, providing rail-to-rail operation thanks to the MOS output stage that delivers very low dropout. The presence of the MOSFET body diodes also offers low impedance to switching overshoots and undershoots. This means that in many cases, external Schottky diode clamps may be eliminated. The outputs of these drivers are designed to withstand 500-mA reverse current without either damage to the device, or logic malfunction.

7.3.6 Low Propagation Delays

The UCC27611 driver device feature best-in-class input-to-output propagation delay of 14 ns (typical) at VDD = 12 V. This promises the lowest level of pulse transmission distortion available from industry standard gate-driver devices for high-frequency switching applications. There is very little variation of the propagation delay with temperature and supply voltage as well, offering typically less than 20-ns propagation delays across the entire range of application conditions.

7.4 Device Functional Modes

[Table 1](#) shows the input and output logic.

Table 1. Truth Table

IN+ PIN	IN- PIN	OUTH PIN	OUTL PIN	OUT (OUTH and OUTL pins tied together)
L	L	High-impedance	L	L
L	H	High-impedance	L	L
H	L	H	High-impedance	H
H	H	High-impedance	L	L

8 Application and Implementation

NOTE

Information in the following applications sections is not part of the TI component specification, and TI does not warrant its accuracy or completeness. TI's customers are responsible for determining suitability of components for their purposes. Customers must validate and test their design implementation to confirm system functionality.

8.1 Application Information

High-current gate-driver devices are required in switching power applications for a variety of reasons. To effect the fast switching of power devices, and reduce associated switching-power losses, a powerful gate-driver device employs between the PWM output of control devices and the gates of the power semiconductor devices. Further, gate-driver devices are indispensable when it is not feasible for the PWM controller device to directly drive the gates of the switching devices. With the advent of digital power, this situation is often encountered because the PWM signal from the digital controller is often a 3.3-V logic signal that is not capable of effectively turning on a power switch. A level-shifting circuitry is required to boost the 3.3-V signal to the gate-drive voltage to fully turn-on the power device and minimize conduction losses. Traditional buffer-drive circuits based on NPN/PNP bipolar transistors in a totem-pole arrangement, as emitter-follower configurations, prove inadequate with digital power because the traditional buffer-drive circuits lack level-shifting capability. Gate-driver devices effectively combine both the level-shifting and buffer-drive functions. Gate-driver devices also find other needs such as minimizing the effect of high-frequency switching noise by locating the high-current driver physically close to the power switch, driving gate-drive transformers and controlling floating power-device gates, reducing power dissipation and thermal stress in controller devices by moving gate-charge power losses into the controller.

8.2 Typical Application

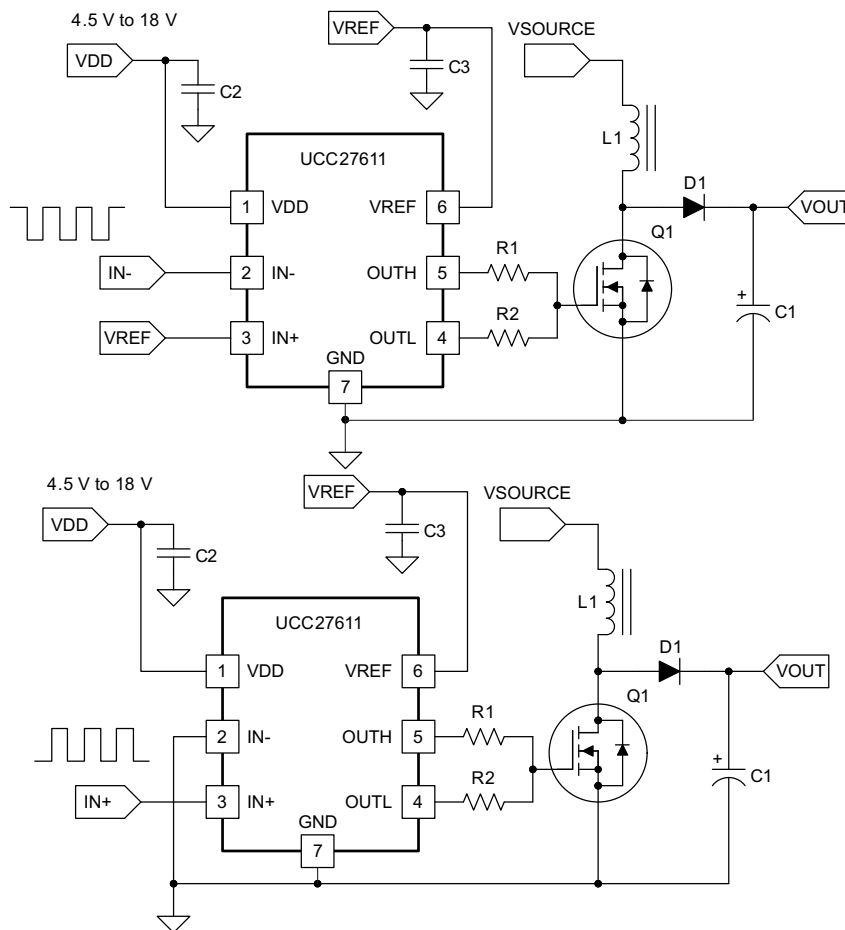

Figure 12. UCC27611 Driving Enhancement Mode GaN FET in Boost Configuration

8.2.1 Design Requirements

The requirements of gate-driver for driving enhancement mode GaN FET are listed as below:

- The headroom between the recommended gate-drive voltage and the absolute maximum rating of GaN transistor is generally marginal. It is critical to drive the GaN FET by an accurate gate-drive supply voltage
- The turnon threshold of the GaN transistor is generally much lower than that of silicon MOSFETs, the risk of Miller turnon and shoot-through becomes a concern for the higher-voltage devices. Low pulldown impedance is necessary to boost the immunity of Miller turnon
- With enhancement mode GaN transistors, the need for minimizing pulldown impedance means that addition pulldown gate resistor and antiparallel diode connection is not recommended. Split the gate pullup and pulldown connections and allow the insertion of external pullup resistance for EMI and voltage-overshoot control is needed
- At high switching speeds, the impact of the gate-drive interconnection impedance becomes important, low-inductance packages with good thermal capability is required for gate driver

Typical Application (continued)

8.2.2 Detailed Design Procedure

8.2.2.1 Gate Drive Supply Voltage

The drive voltage for GaN FETs must be tightly regulated, that's why a linear regulator is integrated in UCC27611 to providing well-regulated 5-V voltage (VREF). Depending on layout and noise generated by the power stage, the parasitic inductance in conjunction with the Miller capacitance of the FET can cause excessive ringing on the gate drive waveform resulting in peaks higher than the regulated VREF drive voltage. With enough energy present, the potential exists to charge the VREF decoupling capacitor higher than the 6-V maximum allowed on a Gallium Nitride transistor. To prevent this from happening, the driver must be close to its own FET to avoid excessive ringing during fast switching transitions, and external gate resistor R_{GH} connected to OUTH pin of driver must be used to limit the turnon speed.

8.2.2.2 Input Configuration

The UCC27611 offers both inverting (IN–) and noninverting (IN+) inputs to satisfy requirements for inverting and noninverting gate drive in a single device type. The design must specify what type of input-to-output configuration must be used. If turning on the power MOSFET when the input signal is in high state is preferred, then a device capable of the noninverting configuration must be selected. If turning off the power MOSFET when the input signal is in high state is preferred, then a device capable of the inverting configuration must be chosen. Once an input pin has been chosen for PWM drive, the other input pin (the unused input pin) must be properly biased to enable the output. The unused input pin cannot remain in a floating condition, because whenever any input pin is left in a floating condition, the output is disabled for safety purposes. Alternatively, the unused input pin can effectively be used to implement an enable and disable function, as explained below.

- To drive the device in a noninverting configuration, apply the PWM control input signal to IN+ pin. In this case, the unused input pin, IN–, must be biased low (tied to GND) to enable the output. Alternately, the IN– pin can be used to implement the enable and disable function using an external logic signal. OUT is disabled when IN– is biased high and OUT is enabled when IN– is biased low
- To drive the device in an inverting configuration, apply the PWM control input signal to IN– pin. In this case, the unused input pin, IN+, must be biased high (For example, tied to VDD) to enable the output. Alternately, the IN+ pin can be used to implement the enable and disable function using an external logic signal. OUT is disabled when IN+ is biased low and OUT is enabled when IN+ is biased high

NOTE

The output pin can be driven into a high state only when IN+ pin is biased high and IN– input is biased low. See [Device Functional Modes](#) for information on device functionality.

The input stage of the driver must preferably be driven by a signal with a short rise or fall time. Take care whenever the driver is used with slowly varying input signals, especially in situations where the device is located in a mechanical socket, or PCB layout is not optimal. High dI/dt current from the driver output coupled with board layout parasitic can cause ground bounce. Because the device features just one GND pin, which may be referenced to the power ground, this may modify the differential voltage between input pins and GND and trigger an unintended change of output state. Because of fast 13-ns propagation delay, this can ultimately result in high-frequency oscillations, which increase power dissipation and pose risk of damage. In the worst case, when a slow input signal is used and PCB layout is not optimal, it may be necessary to add a small capacitor between input pin and ground very close to the driver device. This helps to convert the differential mode noise with respect to the input logic circuitry into common mode noise and avoid unintended change of output state.

Typical Application (continued)

8.2.2.3 Output Configuration

Generally, the switching speed of the power switch during turnon and turnoff must be as fast as possible to minimize switching power losses. The gate driver device must be able to provide the required peak current for achieving the targeted switching speeds for the targeted power MOSFET. In practical designs, the parasitic trace inductance in the gate drive circuit of the PCB has a definitive role to play on the power MOSFET switching speed. The effect of this trace inductance is to limit the dI/dt of the output current pulse of the gate driver. Because of this, the desired switching speed may not be realized, even when theoretical calculations indicate the gate driver can achieve the targeted switching speed. Thus, placing the gate driver device very close to the power MOSFET and designing a tight gate drive-loop with minimal PCB trace inductance is important to realize the full peak-current capability of the gate driver.

The UCC27611 is capable of delivering 4-A source, 6-A sink (asymmetrical drive) at $V_{DD} = 12\text{ V}$. Strong sink capability in asymmetrical drive results in a very low pulldown impedance in the driver output stage which boosts immunity against parasitic, Miller turnon ($C \times dV/dt$ turnon) effect, especially where low gate-charge MOSFETs or emerging wide band-gap GaN power switches are used.

An example of a situation where Miller turnon is a concern is synchronous rectification (SR). In SR application, the dV/dt occurs on MOSFET drain when the MOSFET is already held in OFF state by the gate driver. The current discharging the C_{GD} Miller capacitance during this dV/dt is shunted by the pulldown stage of the driver. If the pulldown impedance is not low enough, then a voltage spike can result in the V_{GS} of the MOSFET, which can result in spurious turnon. This phenomenon is illustrated in Figure 13. UCC27611 offers a best-in-class, 0.35- Ω (typ) pulldown impedance boosting immunity against Miller turnon.

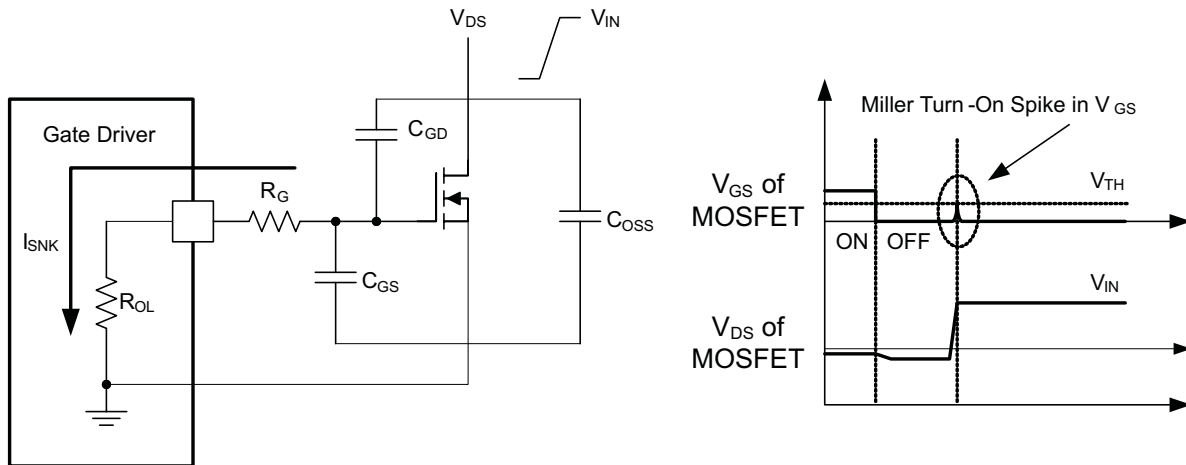

Output stage mitigates Miller turnon effect.

Figure 13. Low-Pulldown Impedance in UCC27611, 4-A and 6-A Asymmetrical Drive

If limiting the rise or fall times to the power device to reduce EMI is necessary, then an external resistance is highly recommended between the output of the driver and the power device. This external resistor has the additional benefit of reducing part of the gate charge related power dissipation in the gate driver device package and transferring it into the external resistor itself. The split outputs of the UCC27611 offer flexibility to adjust the turnon and turnoff speed independently by adding additional impedance in either the turnon path (OUTH) and/or turnoff path (OUTL).

8.2.2.4 Power Dissipation

Power dissipation of the gate driver has two portions as shown in Equation 1:

$$P_{DISS} = P_{DC} + P_{SW} \quad (1)$$

Typical Application (continued)

The DC portion of the power dissipation is $P_{DC} = I_Q \times V_{DD}$ where I_Q is the quiescent current for the driver. The quiescent current is the current consumed by the device to bias all internal circuits such as input stage, reference voltage, logic circuits, protections, and so forth and also any current associated with switching of internal devices when the driver output changes state (such as charging and discharging of parasitic capacitances, parasitic shoot-through and so forth). The UCC27611 device features very low quiescent currents (see [Electrical Characteristics](#)) and contains internal logic to eliminate any shoot-through in the output driver stage. Thus, the effect of the P_{DC} on the total power dissipation within the gate driver can be safely assumed to be negligible.

The power dissipated in the gate-driver package during switching (P_{SW}) depends on the following factors:

- Gate charge required of the power device (usually a function of the drive voltage V_G , which is very close to input bias supply voltage V_{REF} due to low V_{OH} dropout)
- Switching frequency
- Use of external gate resistors

When a driver device is tested with a discrete, capacitive load it is a fairly simple matter to calculate the power that is required from the bias supply. The energy that must be transferred from the bias supply to charge the capacitor is given by [Equation 2](#):

$$E_G = \frac{1}{2} \times C_{LOAD} \times V_{REF}^2$$

where

- C_{LOAD} is load capacitor of driver. (2)

There is an equal amount of energy dissipated when the capacitor is charged. This leads to a total power loss given by [Equation 3](#).

$$P_G = C_{LOAD} \times V_{REF}^2 \times f_{SW}$$

where

- f_{SW} is the switching frequency. (3)

The switching load presented by a power MOSFET and IGBT can be converted to an equivalent capacitance by examining the gate charge required to switch the device. This gate charge includes the effects of the input capacitance plus the added charge needed to swing the drain voltage of the power device as it switches between the ON and OFF states. Most manufacturers provide specifications of typical and maximum gate charge, in nC, to switch the device under specified conditions. Using the gate charge Q_G , one can determine the power that must be dissipated when charging a capacitor. This is done by using the equation, $Q_G = C_{LOAD} \times V_{REF}$, to provide [Equation 4](#) for power:

$$P_G = C_{LOAD} \times V_{REF}^2 \times f_{SW} = Q_G \times V_{REF} \times f_{SW} \quad (4)$$

This power P_G is dissipated in the resistive elements of the circuit when the MOSFET or IGBT is being turned on or off. Half of the total power is dissipated when the load capacitor is charged during turnon, and the other half is dissipated when the load capacitor is discharged during turnoff. When no external gate resistor is employed between the driver and MOSFET and IGBT, this power is completely dissipated inside the driver package. With the use of external gate-drive resistors, the power dissipation is shared between the internal resistance of driver and external gate resistor in accordance to the ratio of the resistances (more power dissipated in the higher resistance component). Based on this simplified analysis, the driver power dissipation during switching is calculated as [Equation 5](#):

$$P_{SW} = Q_G \times V_{REF} \times f_{SW} \left(\frac{R_{ON}}{R_{ON} + R_{GH}} + \frac{R_{OFF}}{R_{OFF} + R_{GL}} \right)$$

where

- $R_{OFF} = R_{OL}$ and $R_{ON} = 2.7 \times R_{OL}$ (effective resistance of pullup structure).
- R_{GH} and R_{GL} is external gate resistors connect to the OUTH and OUTL pins respective. (5)

Typical Application (continued)

8.2.2.5 Thermal Considerations

The useful range of a driver is greatly affected by the drive power requirements of the load and the thermal characteristics of the package. In order for a gate driver to be useful over a particular temperature range, the package must allow for the efficient removal of the heat produced while keeping the junction temperature within rated limits. The thermal metrics for the driver package is summarized in the [Thermal Information](#) of the datasheet. The θ_{JA} metric must be used for comparison of power dissipation between different packages. The ψ_{JT} and ψ_{JB} metrics must be used when estimating the die temperature during actual application measurements. For detailed information regarding the thermal information table, please see the Application Note from Texas Instruments entitled, *Semiconductor and IC Package Thermal Metrics IC Package Thermal Metrics (SPRA953)*.

The UCC27611 device includes a 6-pin DRV package with exposed thermal pad. The exposed thermal pad in DRV package provides designers with an ability to create an excellent heat removal sub-system from the vicinity of the device, thus helping to maintain a lower junction temperature. This pad must be soldered to the copper on the printed circuit board directly underneath the device package. Then a printed circuit-board designed with thermal lands and thermal vias completes a very efficient heat removal subsystem. In such a design, the heat is extracted from the semiconductor junction through the thermal pad, which is then efficiently conducted away from the location of the device on the PCB through the thermal network. This helps to maintain a lower board temperature near the vicinity of the device leading to an overall lower device junction temperature.

8.2.3 Application Curves

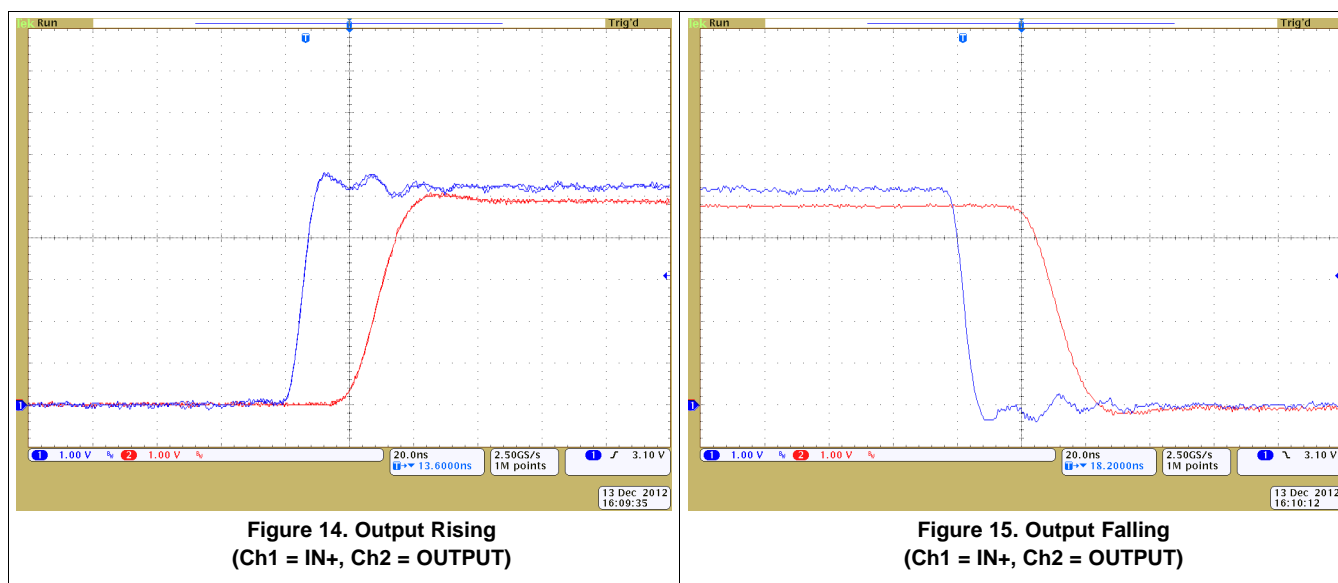

9 Power Supply Recommendations

The bias supply voltage range for which the device is rated to operate is from 4 V to 18 V. The lower end of this range is governed by the internal under voltage-lockout (UVLO) protection feature on the VDD pin supply circuit blocks. Whenever the driver is in UVLO condition when the VDD pin voltage is below the $V_{DD(on)}$ supply start threshold, this feature holds the output low, regardless of the status of the inputs. The upper end of this range is driven by the 20-V absolute maximum voltage rating of the VDD pin of the device (which is a stress rating). Keeping a 2-V margin to allow for transient voltage spikes, the maximum recommended voltage for the VDD pin is 18V.

The UVLO protection feature also involves a hysteresis function. This means that when the VDD pin bias voltage has exceeded the threshold voltage and device begins to operate, and if the voltage drops, then the device continues to deliver normal functionality unless the voltage drop exceeds the hysteresis specification $V_{DD(off)}$. Therefore, ensuring that, while operating at or near the 4-V range, the voltage ripple on the auxiliary power supply output is smaller than the hysteresis specification of the device is important to avoid triggering device shutdown.

During system shutdown, the device operation continues until the VDD pin voltage has dropped below the threshold $V_{DD(off)}$ which must be accounted for while evaluating system shutdown timing design requirements. Likewise, at system startup, the device does not begin operation until the VDD pin voltage has exceeded above the $V_{DD(on)}$ threshold.

Because the driver draws current from the VDD pin to bias all internal circuits, for the best high-speed circuit performance, two VDD bypass capacitors are recommended to prevent noise problems. The use of surface mount components is highly recommended. A 0.1- μ F ceramic capacitor must be located as close as possible to the VDD to GND pins of the gate driver. In addition, a larger capacitor (such as 1- μ F) with relatively low ESR must be connected in parallel and close proximity to help deliver the high-current peaks required by the load. The parallel combination of capacitors must present a low impedance characteristic for the expected current levels and switching frequencies in the application.

The UCC27611 integrate a LDO to provide well-regulated voltage (VREF) to driving GaN FET. The charge for source current pulses delivered by the OUTH pin is supplied through the VREF pin. As a result, every time a current is sourced out of the OUTH pin a corresponding current pulse is delivered into the device through the VREF pin. Thus ensuring that a local bypass capacitor is provided between the VREF and GND pins and located as close to the device as possible for the purpose of decoupling is important. A low ESR, ceramic surface mount capacitor is necessary.

The UCC27611 device is a high-performance driver capable of fast rise and fall times at high-peak currents. Careful PCB layout to reduce parasitic inductances is critical to achieve maximum performance. When a less-than-optimal layout is unavoidable, then TI recommends adding a low capacitance schottky diode to prevent the energy ringing back from the gate and charging up the decoupling capacitor on VREF (see [Figure 16](#)).

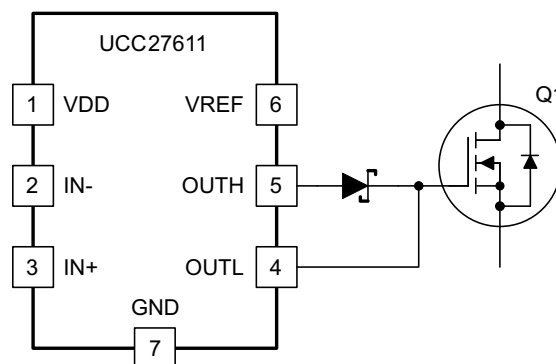

Figure 16. Low-Capacitance Schottky Diode to Prevent From Overcharging

The alternate method would be to add a loading resistor to VREF to bleed off the charge. This method eliminates the additional voltage drop from the diode, but reduces the current available for additional circuits or gate drive if too small a value of resistor is used.

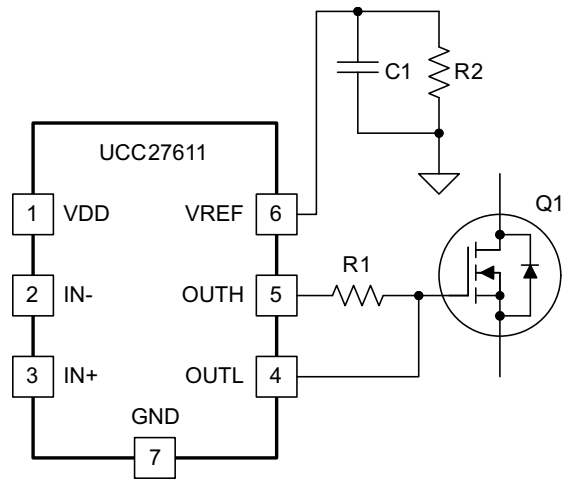

Figure 17. Load Resistor at VREF to Bleed Off the Charge

10 Layout

10.1 Layout Guidelines

Proper PCB layout is extremely important in a high-current, fast-switching circuit to provide appropriate device operation and design robustness. The UCC27611 device gate driver incorporates short-propagation delays and powerful output stages capable of delivering large current peaks with very fast rise and fall times at the gate of power switch to facilitate voltage transitions very quickly. Very high di and dt can cause unacceptable ringing if the trace lengths and impedances are not well controlled. The following circuit layout guidelines are strongly recommended when designing with these high-speed drivers.

- Locate the driver device as close as possible to power device to minimize the length of high-current traces between the output pins and the gate of the power device.
- Locate the VDD and VREF bypass capacitors between VDD, VREF and GND as close as possible to the driver with minimal trace length to improve the noise filtering. These capacitors support high-peak current being drawn from VDD during turnon of power MOSFET. The use of low inductance SMD components such as chip resistors and chip capacitors is highly recommended.
- The turnon and turnoff current loop paths (driver device, power MOSFET and VDD, VREF bypass capacitors) must be minimized as much as possible to keep the stray inductance to a minimum. High di and dt is established in these loops at two instances – during turnon and turnoff transients, which induces significant voltage transients on the output pin of the driver device and gate of the power switch.
- Wherever possible parallel the source and return traces, taking advantage of flux cancellation.
- Separate power traces and signal traces, such as output and input signals.
- Star-point grounding is a good way to minimize noise coupling from one current loop to another. The GND of the driver must be connected to the other circuit nodes such as source of power switch, ground of PWM controller and so forth at one, single point. The connected paths must be as short as possible to reduce inductance and be as wide as possible to reduce resistance.
- Use a ground plane to provide noise shielding. Fast rise and fall times at OUT may corrupt the input signals during transition. The ground plane must not be a conduction path for any current loop. Instead the ground plane must be connected to the star-point with one single trace to establish the ground potential. In addition to noise shielding, the ground plane can help in power dissipation as well.
- In noisy environments, it may be necessary to tie the unused Input pin of UCC27611 device to VDD or VREF (in case of IN+) or GND (in case of IN-) using short traces to ensure that the output is enabled and to prevent noise from causing malfunction in the output.

10.2 Layout Example

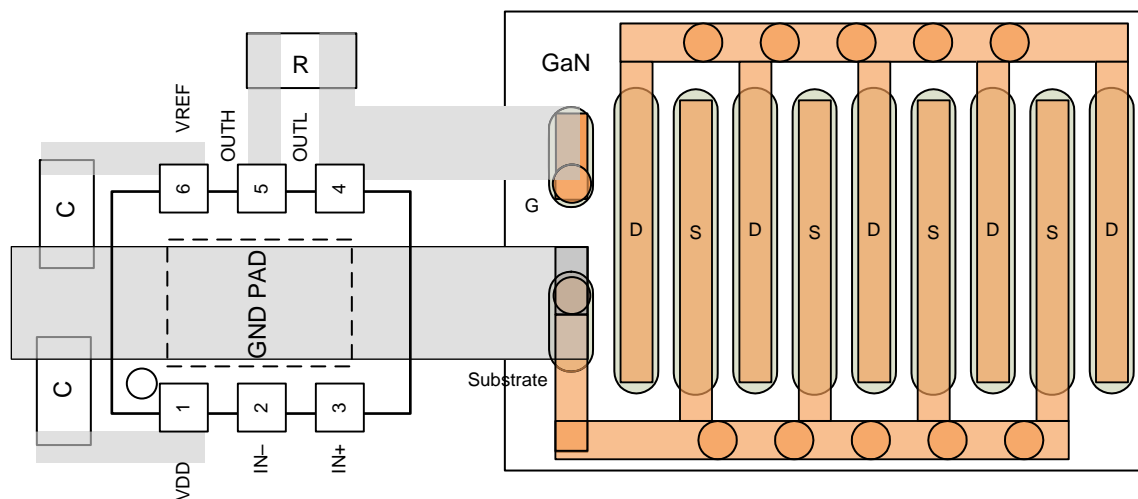

Figure 18. PCB Layout Recommendation

11 器件和文档支持

11.1 文档支持

11.1.1 相关文档

请参阅如下相关文档：

- 《[半导体和 IC 封装热指标](#)》（文献编号：SPRA953）
- 《[使用 UCC27611OLEVM-203](#)》(SLUUA64)

11.2 接收文档更新通知

如需接收文档更新通知，请访问 www.ti.com.cn 网站上的器件产品文件夹。单击右上角的 [通知我](#) 进行注册，即可每周接收产品信息更改摘要。有关更改的详细信息，请查看任何已修订文档中包含的修订历史记录。

11.3 社区资源

下列链接提供到 TI 社区资源的连接。链接的内容由各个分销商“按照原样”提供。这些内容并不构成 TI 技术规范，并且不一定反映 TI 的观点；请参阅 TI 的 [《使用条款》](#)。

TI E2E™ 在线社区 [TI 的工程师对工程师 \(E2E\) 社区](#)。此社区的创建目的在于促进工程师之间的协作。在 e2e.ti.com 中，您可以咨询问题、分享知识、拓展思路并与同行工程师一道帮助解决问题。

设计支持 [TI 参考设计支持](#) 可帮助您快速查找有帮助的 E2E 论坛、设计支持工具以及技术支持的联系信息。

11.4 商标

E2E is a trademark of Texas Instruments.
All other trademarks are the property of their respective owners.

11.5 静电放电警告



这些装置包含有限的内置 ESD 保护。存储或装卸时，应将导线一起截短或将装置放置于导电泡棉中，以防止 MOS 门极遭受静电损伤。

11.6 Glossary

[SLYZ022](#) — *TI Glossary*.

This glossary lists and explains terms, acronyms, and definitions.

12 机械、封装和可订购信息

以下页面包含机械、封装和可订购信息。这些信息是指定器件的最新可用数据。数据如有变更，恕不另行通知，且不会对此文档进行修订。如需获取此数据表的浏览器版本，请参阅左侧的导航栏。

PACKAGING INFORMATION

Orderable Device	Status (1)	Package Type	Package Drawing	Pins	Package Qty	Eco Plan (2)	Lead finish/ Ball material (6)	MSL Peak Temp (3)	Op Temp (°C)	Device Marking (4/5)	Samples
UCC27611DRVR	ACTIVE	WSON	DRV	6	3000	RoHS & Green	NIPDAU	Level-1-260C-UNLIM	-40 to 140	7611	Samples
UCC27611DRVT	ACTIVE	WSON	DRV	6	250	RoHS & Green	NIPDAU	Level-1-260C-UNLIM	-40 to 140	7611	Samples

(1) The marketing status values are defined as follows:

ACTIVE: Product device recommended for new designs.

LIFEBUY: TI has announced that the device will be discontinued, and a lifetime-buy period is in effect.

NRND: Not recommended for new designs. Device is in production to support existing customers, but TI does not recommend using this part in a new design.

PREVIEW: Device has been announced but is not in production. Samples may or may not be available.

OBSOLETE: TI has discontinued the production of the device.

(2) **RoHS:** TI defines "RoHS" to mean semiconductor products that are compliant with the current EU RoHS requirements for all 10 RoHS substances, including the requirement that RoHS substance do not exceed 0.1% by weight in homogeneous materials. Where designed to be soldered at high temperatures, "RoHS" products are suitable for use in specified lead-free processes. TI may reference these types of products as "Pb-Free".

RoHS Exempt: TI defines "RoHS Exempt" to mean products that contain lead but are compliant with EU RoHS pursuant to a specific EU RoHS exemption.

Green: TI defines "Green" to mean the content of Chlorine (Cl) and Bromine (Br) based flame retardants meet JS709B low halogen requirements of <=1000ppm threshold. Antimony trioxide based flame retardants must also meet the <=1000ppm threshold requirement.

(3) MSL, Peak Temp. - The Moisture Sensitivity Level rating according to the JEDEC industry standard classifications, and peak solder temperature.

(4) There may be additional marking, which relates to the logo, the lot trace code information, or the environmental category on the device.

(5) Multiple Device Markings will be inside parentheses. Only one Device Marking contained in parentheses and separated by a "~" will appear on a device. If a line is indented then it is a continuation of the previous line and the two combined represent the entire Device Marking for that device.

(6) Lead finish/Ball material - Orderable Devices may have multiple material finish options. Finish options are separated by a vertical ruled line. Lead finish/Ball material values may wrap to two lines if the finish value exceeds the maximum column width.

Important Information and Disclaimer:The information provided on this page represents TI's knowledge and belief as of the date that it is provided. TI bases its knowledge and belief on information provided by third parties, and makes no representation or warranty as to the accuracy of such information. Efforts are underway to better integrate information from third parties. TI has taken and continues to take reasonable steps to provide representative and accurate information but may not have conducted destructive testing or chemical analysis on incoming materials and chemicals. TI and TI suppliers consider certain information to be proprietary, and thus CAS numbers and other limited information may not be available for release.

In no event shall TI's liability arising out of such information exceed the total purchase price of the TI part(s) at issue in this document sold by TI to Customer on an annual basis.

TAPE AND REEL INFORMATION

QUADRANT ASSIGNMENTS FOR PIN 1 ORIENTATION IN TAPE

*All dimensions are nominal

Device	Package Type	Package Drawing	Pins	SPQ	Reel Diameter (mm)	Reel Width W1 (mm)	A0 (mm)	B0 (mm)	K0 (mm)	P1 (mm)	W (mm)	Pin1 Quadrant
UCC27611DRVR	WSON	DRV	6	3000	180.0	8.4	2.3	2.3	1.15	4.0	8.0	Q2
UCC27611DRVT	WSON	DRV	6	250	180.0	8.4	2.3	2.3	1.15	4.0	8.0	Q2

TAPE AND REEL BOX DIMENSIONS



*All dimensions are nominal

Device	Package Type	Package Drawing	Pins	SPQ	Length (mm)	Width (mm)	Height (mm)
UCC27611DRVR	WSON	DRV	6	3000	182.0	182.0	20.0
UCC27611DRVT	WSON	DRV	6	250	182.0	182.0	20.0

GENERIC PACKAGE VIEW

DRV 6

WSO - 0.8 mm max height

PLASTIC SMALL OUTLINE - NO LEAD



Images above are just a representation of the package family, actual package may vary.
Refer to the product data sheet for package details.

4206925/F



4222173/B 04/2018

NOTES:

1. All linear dimensions are in millimeters. Any dimensions in parenthesis are for reference only. Dimensioning and tolerancing per ASME Y14.5M.
2. This drawing is subject to change without notice.
3. The package thermal pad must be soldered to the printed circuit board for thermal and mechanical performance.

EXAMPLE BOARD LAYOUT

DRV0006A

WSON - 0.8 mm max height

PLASTIC SMALL OUTLINE - NO LEAD

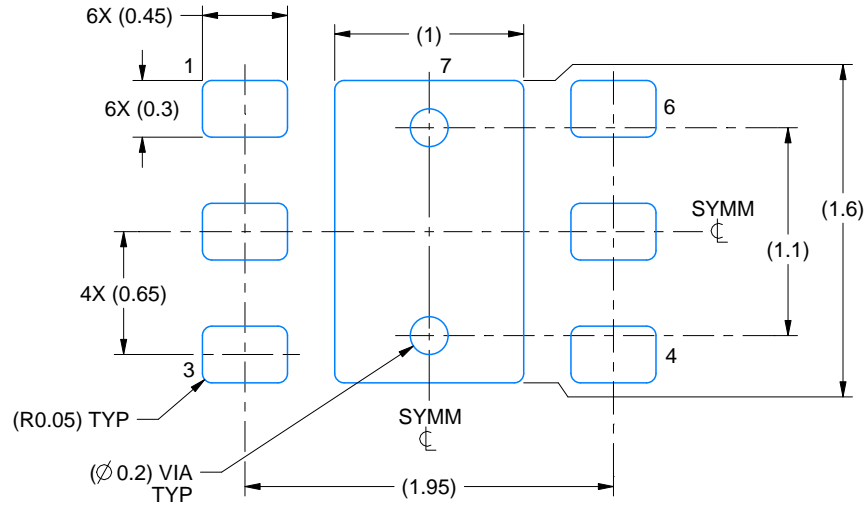

LAND PATTERN EXAMPLE
SCALE:25X

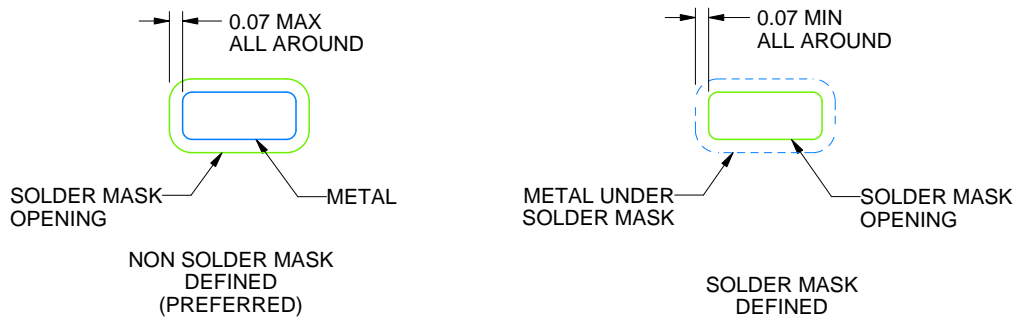

SOLDER MASK DETAILS

4222173/B 04/2018

NOTES: (continued)

4. This package is designed to be soldered to a thermal pad on the board. For more information, see Texas Instruments literature number SLUA271 (www.ti.com/lit/sluea271).
5. Vias are optional depending on application, refer to device data sheet. If some or all are implemented, recommended via locations are shown.

EXAMPLE STENCIL DESIGN

DRV0006A

WSON - 0.8 mm max height

PLASTIC SMALL OUTLINE - NO LEAD



SOLDER PASTE EXAMPLE
BASED ON 0.125 mm THICK STENCIL

EXPOSED PAD #7
88% PRINTED SOLDER COVERAGE BY AREA UNDER PACKAGE
SCALE:30X

4222173/B 04/2018

NOTES: (continued)

6. Laser cutting apertures with trapezoidal walls and rounded corners may offer better paste release. IPC-7525 may have alternate design recommendations.

重要声明和免责声明

TI“按原样”提供技术和可靠性数据（包括数据表）、设计资源（包括参考设计）、应用或其他设计建议、网络工具、安全信息和其他资源，不保证没有瑕疵且不做任何明示或暗示的担保，包括但不限于对适销性、某特定用途方面的适用性或不侵犯任何第三方知识产权的暗示担保。

这些资源可供使用 TI 产品进行设计的熟练开发人员使用。您将自行承担以下全部责任：(1) 针对您的应用选择合适的 TI 产品，(2) 设计、验证并测试您的应用，(3) 确保您的应用满足相应标准以及任何其他功能安全、信息安全、监管或其他要求。

这些资源如有变更，恕不另行通知。TI 授权您仅可将这些资源用于研发本资源所述的 TI 产品的应用。严禁对这些资源进行其他复制或展示。您无权使用任何其他 TI 知识产权或任何第三方知识产权。您应全额赔偿因在这些资源的使用中对 TI 及其代表造成的任何索赔、损害、成本、损失和债务，TI 对此概不负责。

TI 提供的产品受 [TI 的销售条款](#) 或 [ti.com](#) 上其他适用条款/TI 产品随附的其他适用条款的约束。TI 提供这些资源并不会扩展或以其他方式更改 TI 针对 TI 产品发布的适用的担保或担保免责声明。

TI 反对并拒绝您可能提出的任何其他或不同的条款。

邮寄地址：Texas Instruments, Post Office Box 655303, Dallas, Texas 75265
Copyright © 2024，德州仪器 (TI) 公司