

# **Hybrid Battery Charger With Load Control for Telecom Equipment**

---



---

## **ABSTRACT**

Commercial telecom equipment needs multiple power input systems to ensure continuous network connectivity. The load must be backed up to different sources. This application note describes a synchronous-buck-based reference design using MSP430, CSD87350 power blocks and the UCC27211 half-bridge driver to use multiple OR'ed inputs (solar and AC/DC adaptor) to charge a 12-V SLA battery. Priority charging is used when solar energy is available. Seamless transfer between two sources ensures battery is always charged when inputs are available. It runs MPPT algorithms to charge while on solar input and conventional CC/CV charging when working from an adaptor input. Multiple protection schemes ensure it is a robust design.

<b>Topic</b>	<b>Page</b>
<b>1 Design Specifications</b> .....	<b>2</b>
<b>2 Block Diagram</b> .....	<b>3</b>
<b>3 System Explanation and Design</b> .....	<b>3</b>
<b>4 Software Flow</b> .....	<b>5</b>
<b>5 Schematics</b> .....	<b>10</b>
<b>6 Test Results</b> .....	<b>12</b>

**Trademarks**
**1 Design Specifications**
**Table 1. Design Specifications**

Parameter	Description	Value
V <sub>IN</sub> range	Panel	16.5 to 21 V
	Adaptor	15.5 to 16 V
Battery specifications	Capacity	12 V, 100 Ah
Charging specifications	Charging current	7 A
	Voltage during CV mode charging	14.2 V
F <sub>SW</sub>	Switch frequency	100 kHz
Output specifications	Load current	4 A
	Output voltage	10.2 to 14.2 V
Protection features	<ul style="list-style-type: none"> <li>• Hot swappable load</li> <li>• Output short circuit</li> <li>• Reverse polarity protection</li> <li>• Two level overcurrent protection</li> <li>• Battery UVLO</li> <li>• Overtemperature protection</li> </ul>	

## 2 Block Diagram

Figure 1 shows the block level implementation of the system.

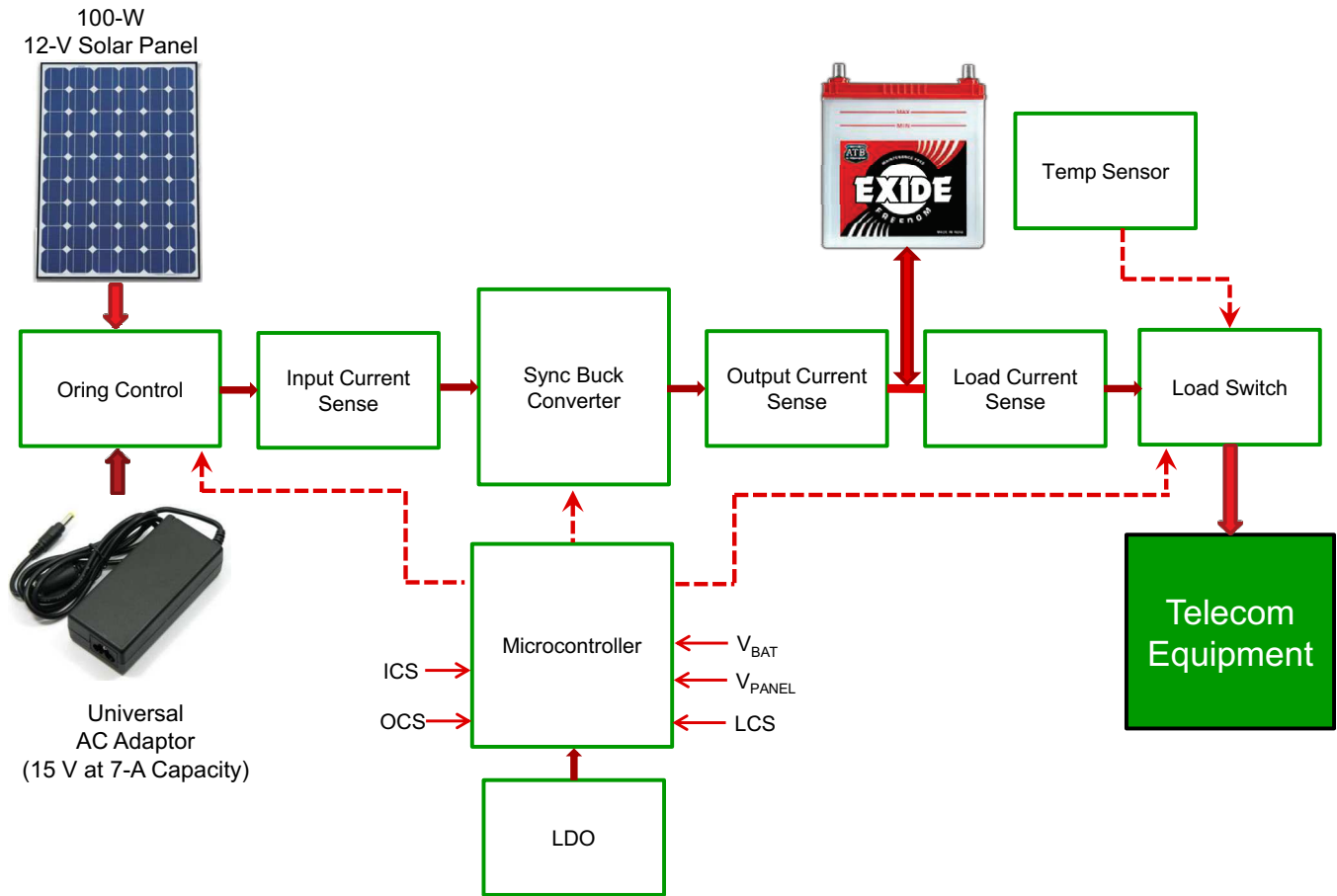

Figure 1.

## 3 System Explanation and Design

### 3.1 Power Source Control and Monitoring

The telecom equipment (load) is always powered either from a solar panel, AC/DC adaptor, or the battery. As long as solar energy from the panel is available, priority charging is used to deliver the required power (average 17 V and current sufficient enough to manage load or to charge battery). If panel voltage drops below adapter (15 V), the charge controller microcontroller turns off the panel switch and turns on the AC/DC adaptor switch, which also ensures no leakage of the stronger source into the weaker one. Two 30-V, ultra-low  $R_{DS(on)}$  FETs from TI (CSD17527Q5A) are selected for this purpose. The simple transistor is used for proving the drive from the microcontroller.

### 3.2 Synchronous Buck Power Stage

The synchronous buck converter has better efficiency and lower loss compared to asynchronous topology because a diode on the bottom side is replaced with a low  $R_{DS(on)}$  value. A single 30-V, 25-A power block from TI (CSD87350Q5D) is selected for this. The advantage of a power block is the smaller package and ease of layout eliminating parasitics of board layout of high frequency hot nodes. The microcontroller PWM module can generate multiple PWMs on the same timer base. Each output can be configured for different output modes, for example, toggle, reset/on, reset/off, always on, and so forth. With this flexible logic, the user can achieve complimentary logic with required dead band. However, a half-bridge driver

with a floating high side drive is required to drive the high side and low side MOSFETs. The UCC27211, [UCC2721x 120-V Boot, 4-A Peak, High-Frequency High-Side and Low-Side Driver](#), has high drive strength, low propagation delays, and excellent delay matching to optimize the timing of the buck power stage resulting in minimal switching loss. The other power stage components (inductor and capacitor) calculations are designed using standard equations of the buck converter based on the prior specifications.

- $L_{OUT}$  (cal) = 12.67  $\mu$ H, selected  $L_{OUT}$  = 10  $\mu$ H, from Würth Electronics
- Selected  $C_{OUT}$  = 47  $\mu$ F  $\times$  1; 22  $\mu$ F  $\times$  2

### 3.3 Current Sense Inputs

To ensure continuity to ground loop, a high-side sense circuit was used. A zero-drift instrumentation amplifier from TI, INA282, with a 50-V/V gain, wide common-mode input range is selected for this application.

### 3.4 Load Management

A simple load switch with hotswap control from TI TPS25910 is used for monitoring the load behavior. If there is any short or overload, it immediately trips sending it into a hiccup mode on the load. The fast-trip comparator of the microcontroller also quickly disables the PWM. This is second-level protection for the load. To prevent the load from discharging back into the source, a blocking FET (CSD17313Q2) from TI is used. It is controlled by the load switch.

### 3.5 Microcontroller

A MSP430F5132 microcontroller is used in this application. See [Section 4](#) for further details of the software routines.

### 3.6 LDO and Temperature Sensor

A simple OR'ed supply is used as the input of the LDO to ensure that power to the controller is always available to sense any inappropriate condition. The 3.3 V generated by the LDO (TPS73801) is used to power the MCU, LEDs, instrumentation amplifiers, and a simple thermostat TMP709, which is used for tripping the load in case there is any abnormal increase in the temperature.

### 3.7 Battery Management

The section explains the battery management software portion in the microcontroller. It checks for the state-of-charge of the battery and applies the charging profile appropriately. This application uses a lead-acid battery. The following list shows the battery properties that are considered while charging.

- Minimum 2.10 V per cell is considered as a good battery
- Cells in a string are not the same strength, some are weak and some are strong.
- Should not be charged above 50°C
- Overcharging increases the risk of hydrogen gassing on the positive plate.
- Undercharging increases sulfation on the negative plate.
- Battery charge profile is in constant current mode until battery attains, for example, 70%, constant voltage mode from 70% to 90% and float charge after that.

### 3.8 Maximum Power Point Tracking Algorithm

A simple MPPT algorithm known as perturb and observe is used for controlling this system. As explained in the *PWM Resolution* section, every one count of PWM timer yields 0.04% of duty cycle variation, which is "fine" enough to achieve smoother and slower tracking. With this at MPP stage, there will be 0.04% oscillation which may be negligible in a low-power application. If duty cycle variation is increased more than 1 count, tracking is faster and reduces the variation to minimize the MPP stage oscillations. This also resembles incremental conductance method. It monitors battery/load current with respect to  $\Delta V$  applied to the converter, increasing the  $\Delta V$  drives to MPP faster and at the MPP stage reduces the  $\Delta V$  and settles smoothly at MPP.

## 4 Software Flow

This application uses the MSP430F5132 microcontroller. The following are key features, which enable efficient usage of resources to achieve an efficient solar power convertor.

MSP430F5132 key features supporting efficiency expectation:

- Fully operates from 3.6 to 1.8 V
- Only 180- $\mu$ A/MHz active current, lowest current at shut down is 0.25  $\mu$ A
- Fast wake-up, less than 5  $\mu$ s from stand by
- 200 KSPS, 10-bit ADC, with just 110- $\mu$ A current consumption with built-in reference
- Hi-resolution timer/PWM = 4-ns minimum pulse duration, 250- $\mu$ A current consumption

### 4.1 PWM Resolution

The MSP430F5132 has a special hi-resolution timer, timer-D. This timer can be programmed to generate high switching frequency to accommodate a smaller inductor's size. This timer is clocked from the following sources:

- MCLK/SMCLK – Maximum range is 16 MHz
- ACLK – Maximum 32 kHz
- Special timer-D clock generator of the following values:
  - 64 MHz
  - 128 MHz
  - 200 MHz
  - 256 MHz

Effective number of bits (ENOB) is an important parameter in achieving smoother control, thereby reducing switching noise and protecting the battery from stress caused by larger voltage variations caused in a low-resolution system.

$$\text{ENOB} = \text{Log}_2(\text{Module clock} / \text{Output frequency}) \quad (1)$$

This application requires 100-kHz switching frequency. Therefore, the following settings provide,

Module clock = 256 MHz

Output frequency = 100 kHz

ENOB = 11.36 bits

$$V_{\text{OUT}} = D \times V_{\text{IN}}$$

where

- D = Duty cycle or on-time of the switch
  - $V_{\text{IN}}$  = Input voltage (from battery, solar panel, or ACDC adapter)
  - $V_{\text{OUT}}$  = Output voltage
- (2)

Consider the converter to be 100% efficient. Therefore, no loss factor is taken into account in this calculation. For a single bit change in D varies by approximately 4 ns in a 100-kHz period wave, which is 0.038% of  $V_{\text{IN}}$ ; if a  $V_{\text{IN}}$  of 17,  $V_{\text{OUT}}$  varies by 0.00646 V.

### 4.2 ADC Module

This device has 10-bit SAR ADC, speed can be configured for 50ksps for low power or 200ksps for faster processing. This application can go slow, which helps to conserve additional power loss caused by the ADC module itself (refer to the data sheet for power consumption data). This module can be operated independently without sharing the CPU clock. Hence, the CPU can be placed in low-power mode, enabling only the ADC to function.

A special ADC DMA can be configured to scan all channels and interrupt the CPU when data is available at the RAM for further processing. This application requires 6 channels: battery current, panel current, battery voltage, panel voltage, load current, and temperature sensor. Therefore, a 6-channel conversion is required every loop, until then the CPU can be put in IDLE to conserve power.

### 4.3 ADC Measurement Range

This MCU has a 10-bit SAR ADC, input voltage range is 0 V to AVCC, which can be up to 3.6 V (refer to data sheet for more electrical data). Hence, input signal strength can be from 3.3 mV per count of ADC until 3.3 V (1023 counts) can be sensed. Sense resistors are 5 mΩ. Hence, minimum current sensible from panel/load/battery with a gain of 50 is about 13 mA.

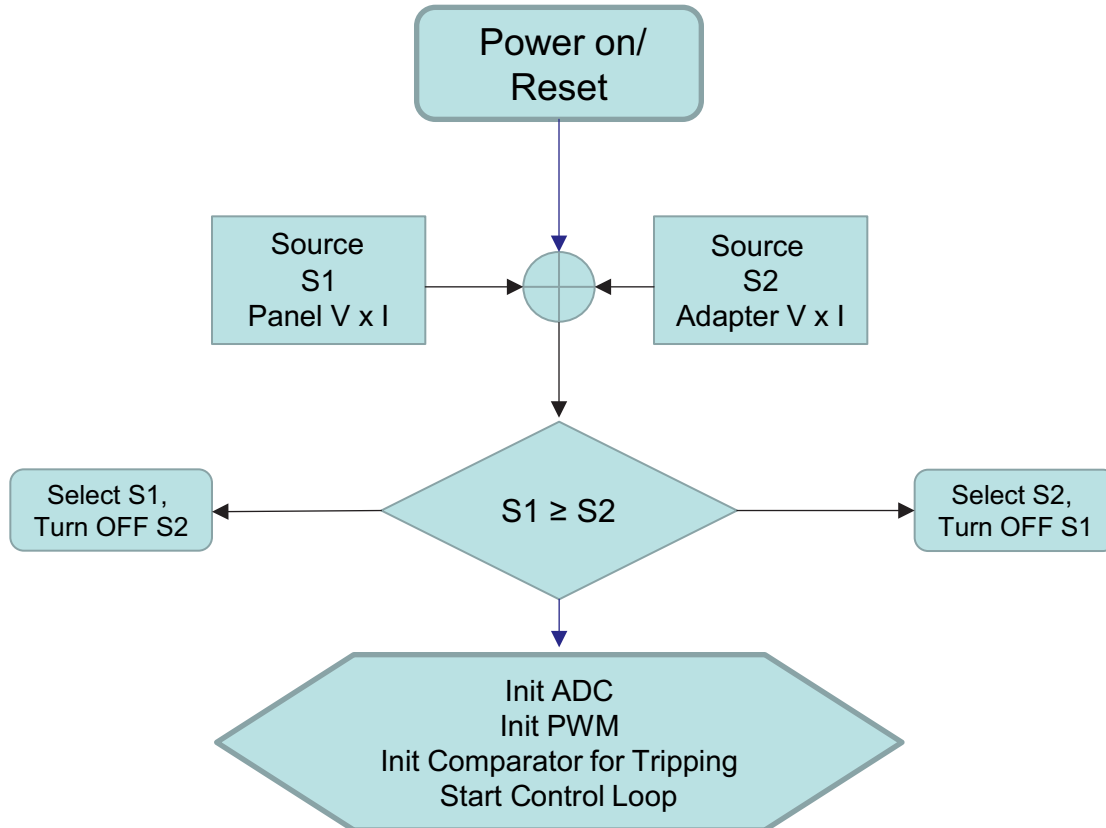

**Figure 2. Initialization Flow Chart**

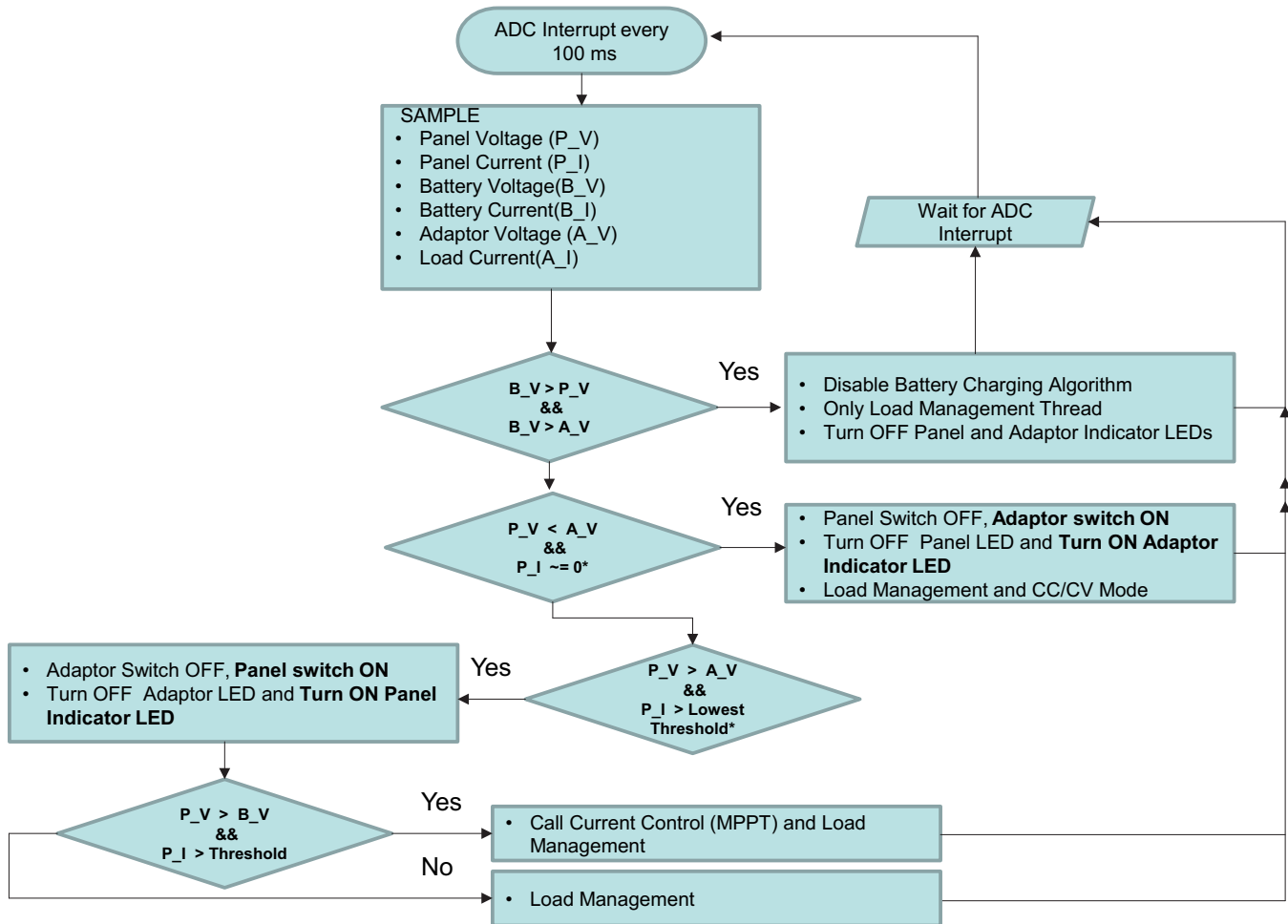

Figure 3. Control Loop Flow Chart

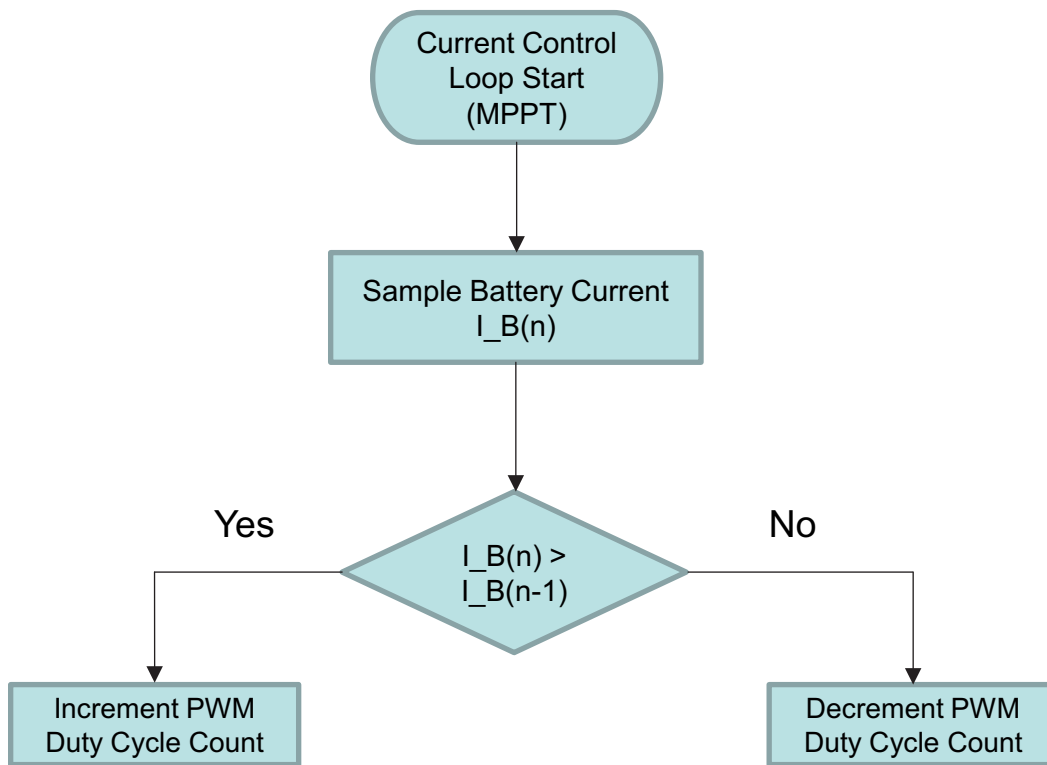

Figure 4. MPPT Algorithm Flow Chart

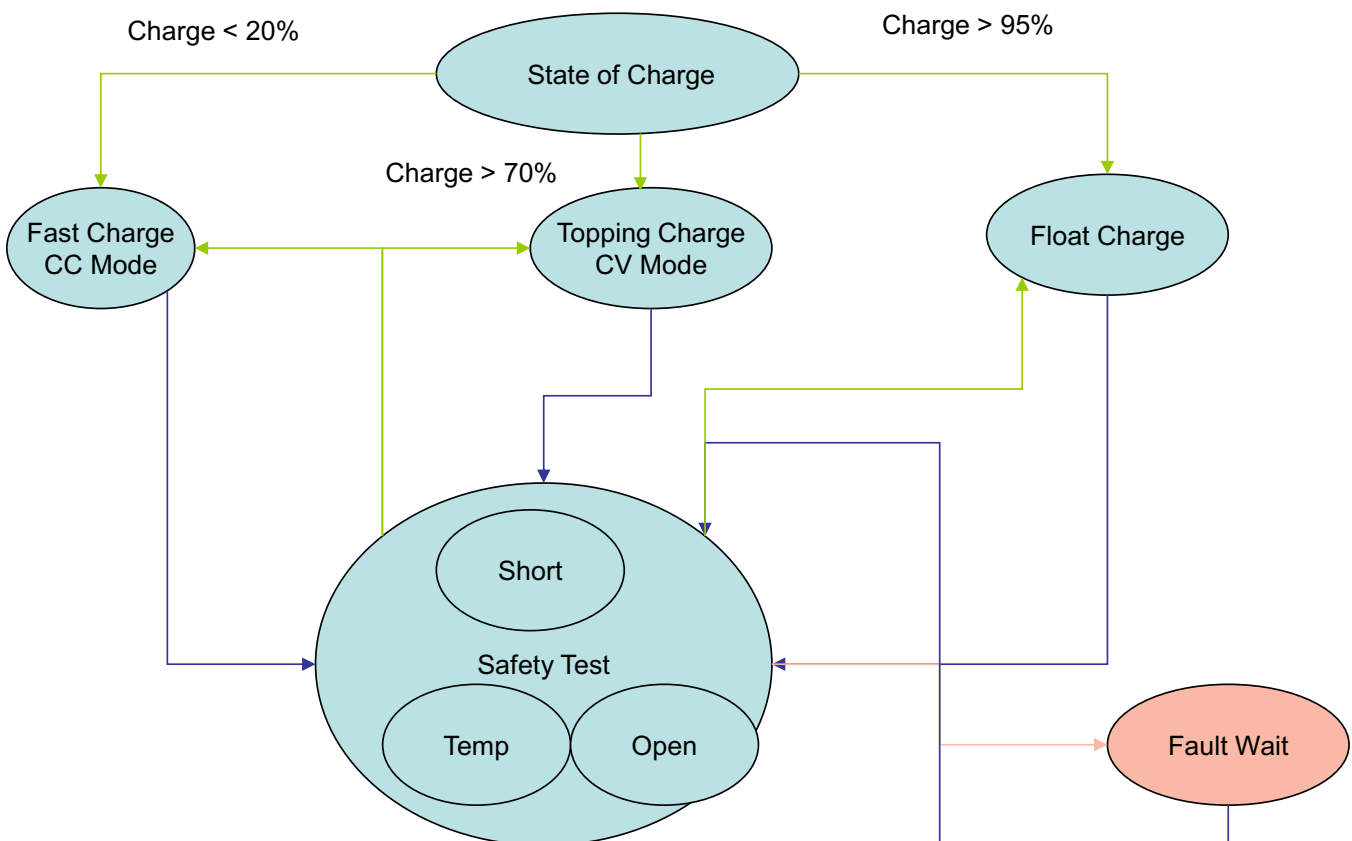

Figure 5. Battery Management Flow Chart



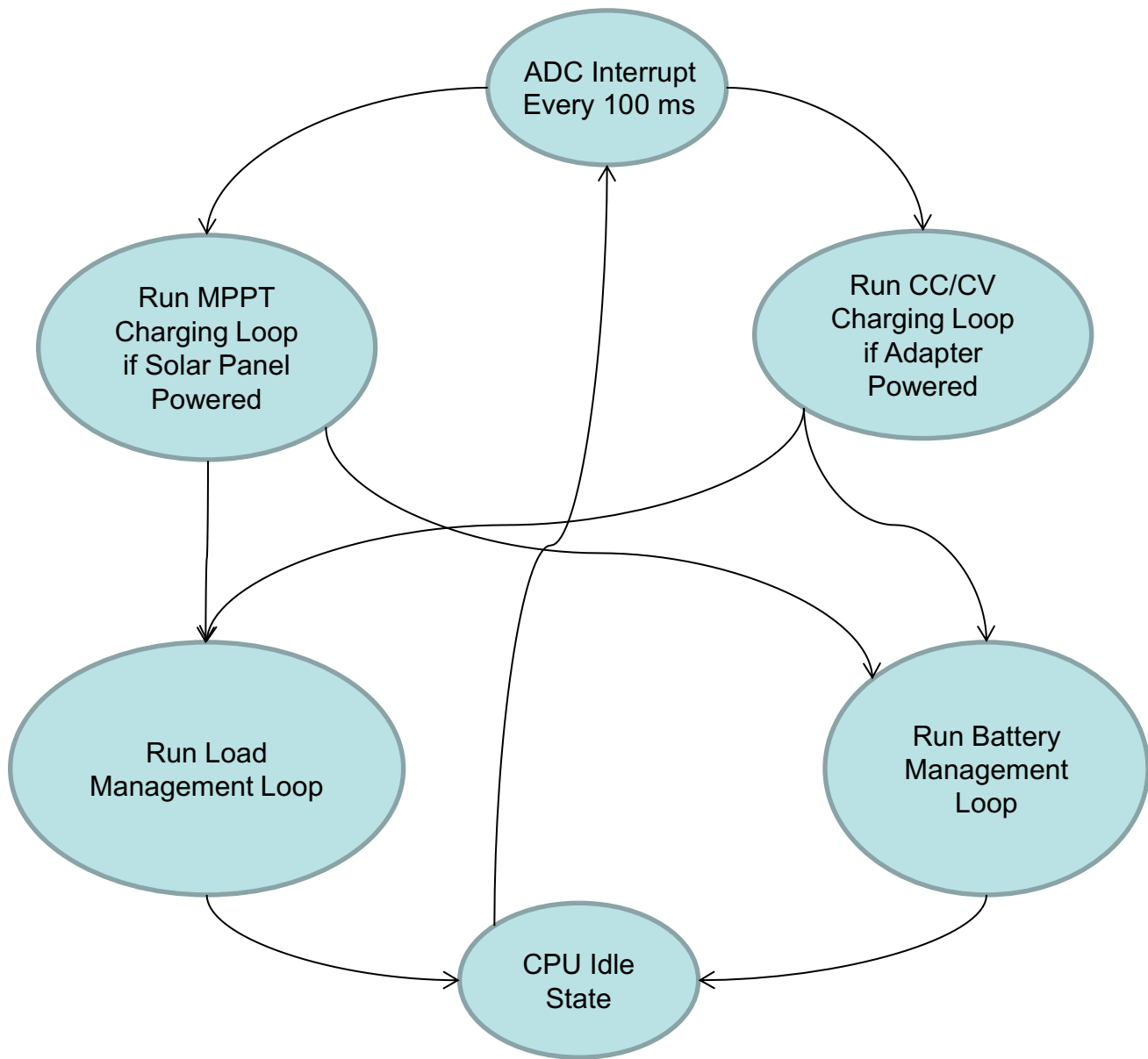
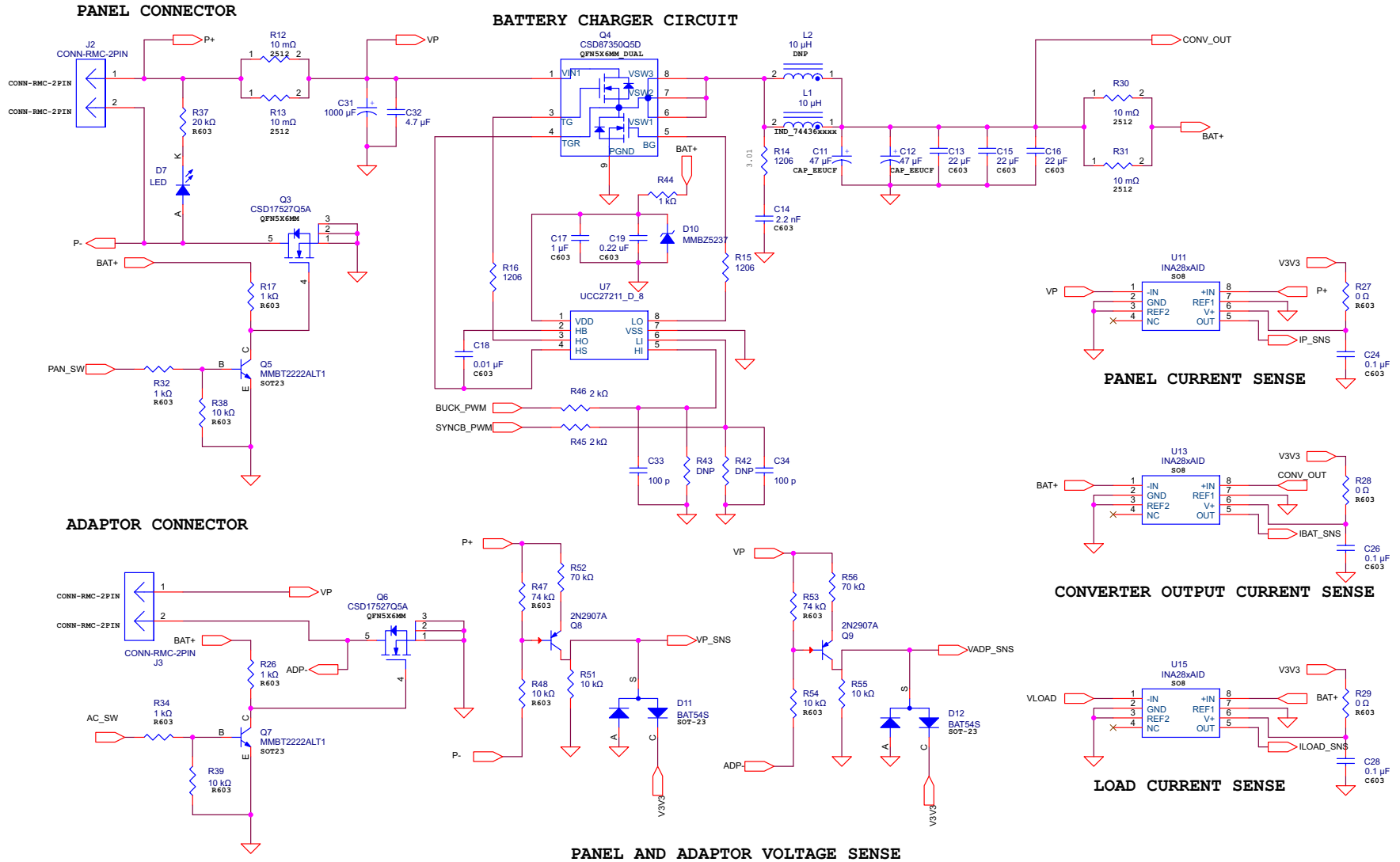
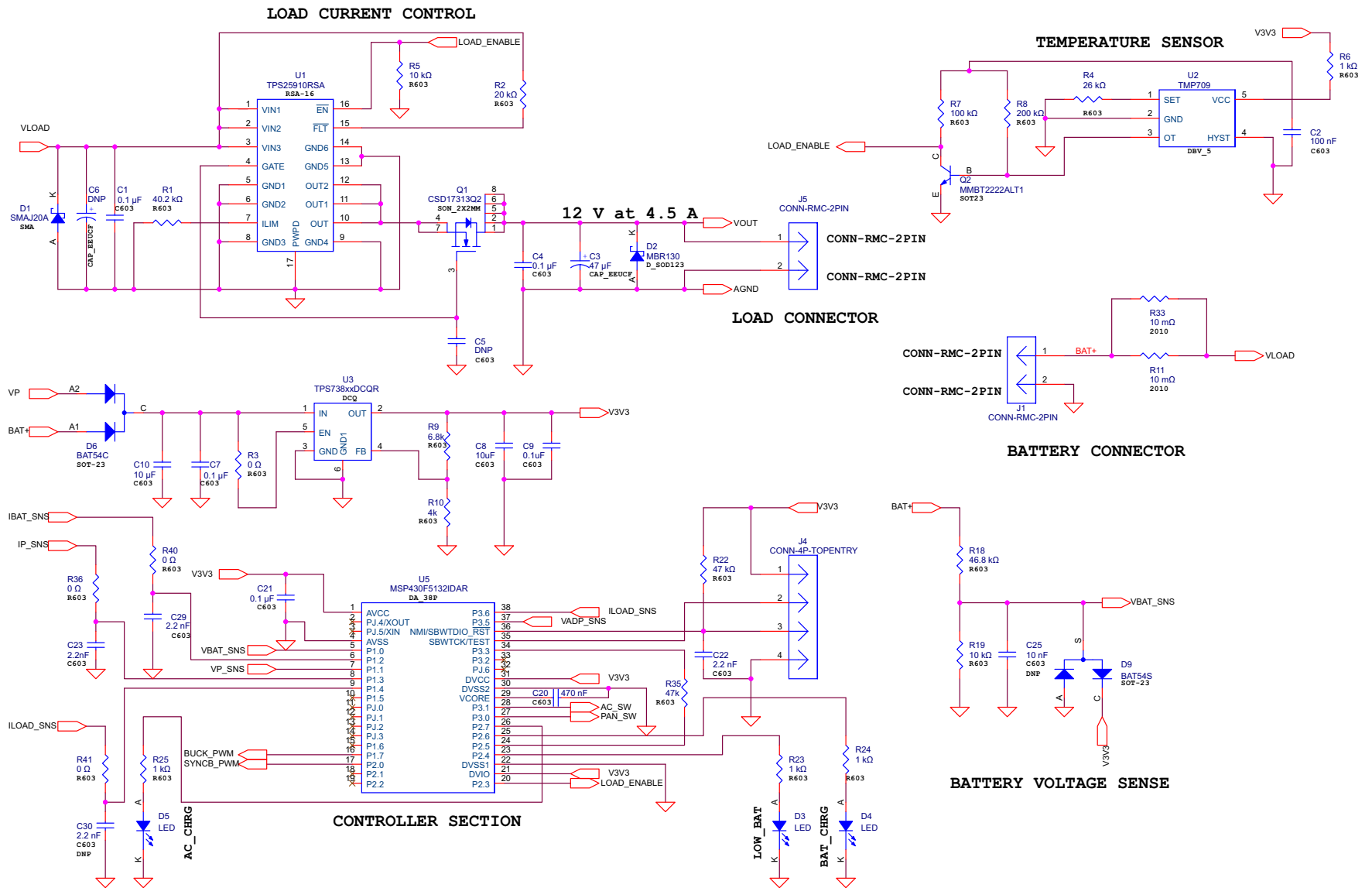

Figure 6. Control Loop Logic

## 5 Schematics





## 6 Test Results

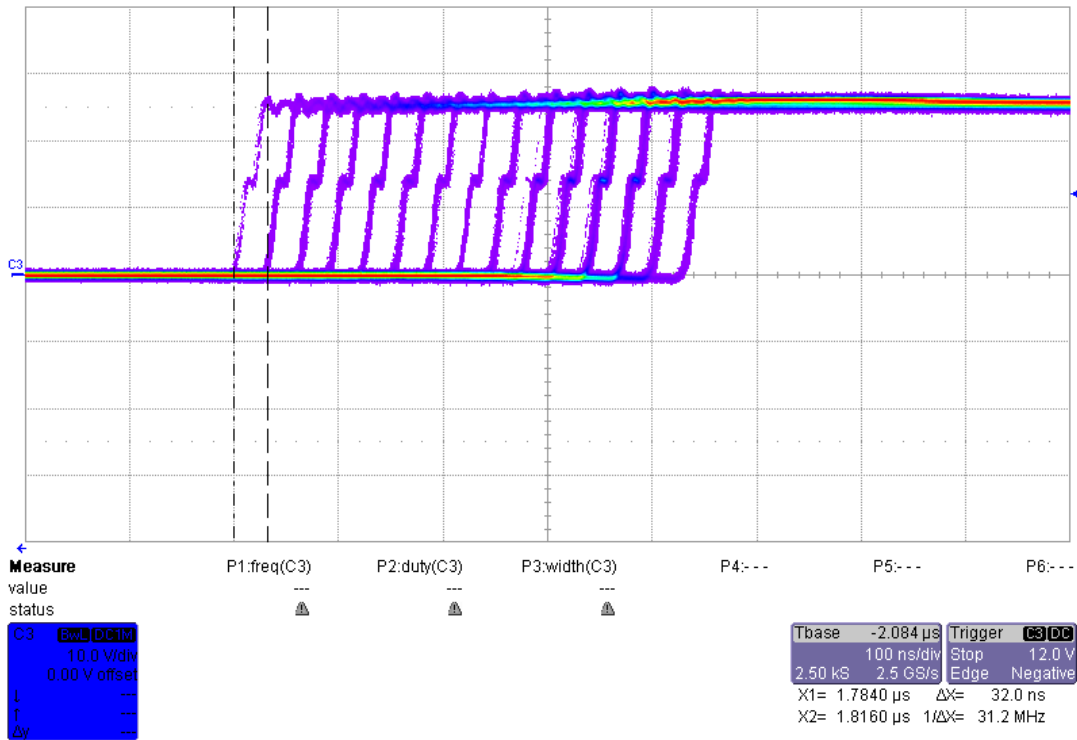

Figure 7. Variation of the Duty Cycle from the Controller

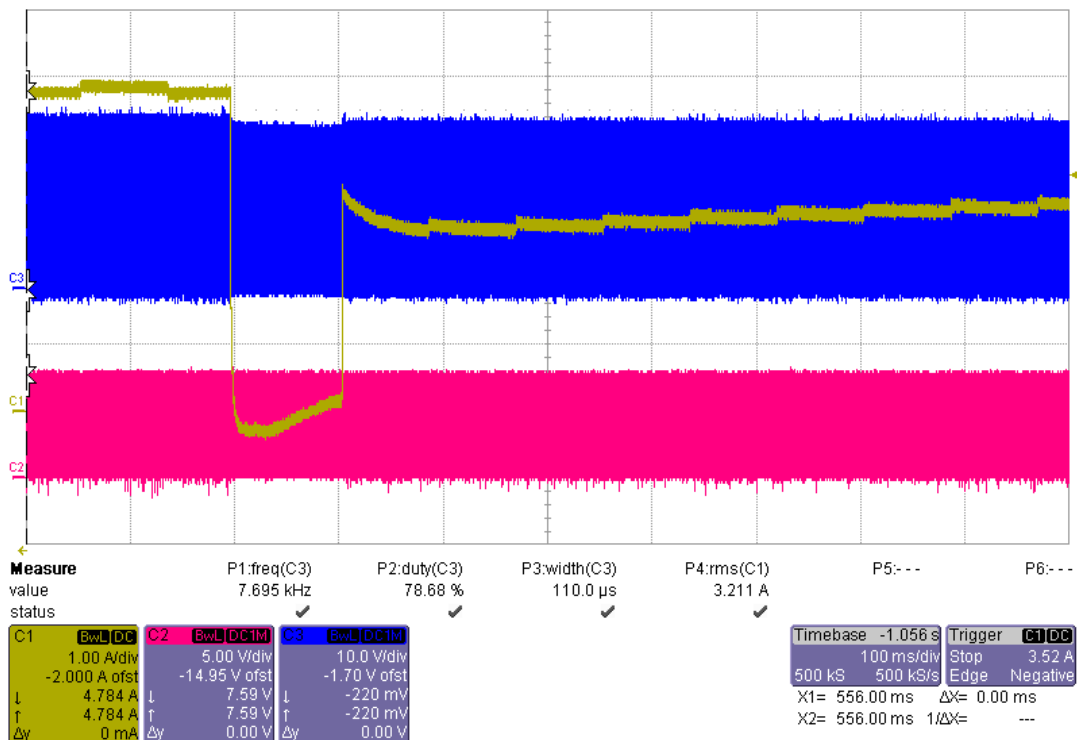

Figure 8. Seamless Transfer from Panel to Adaptor

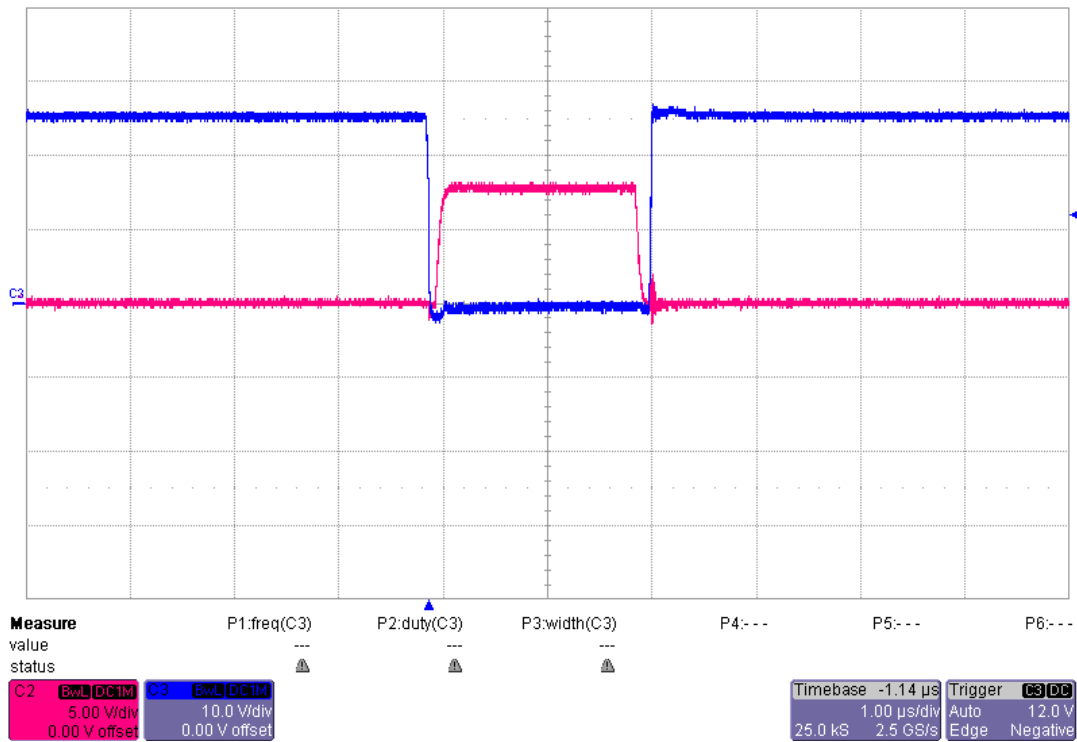

Figure 9. Output PWM Pulses from UCC27211

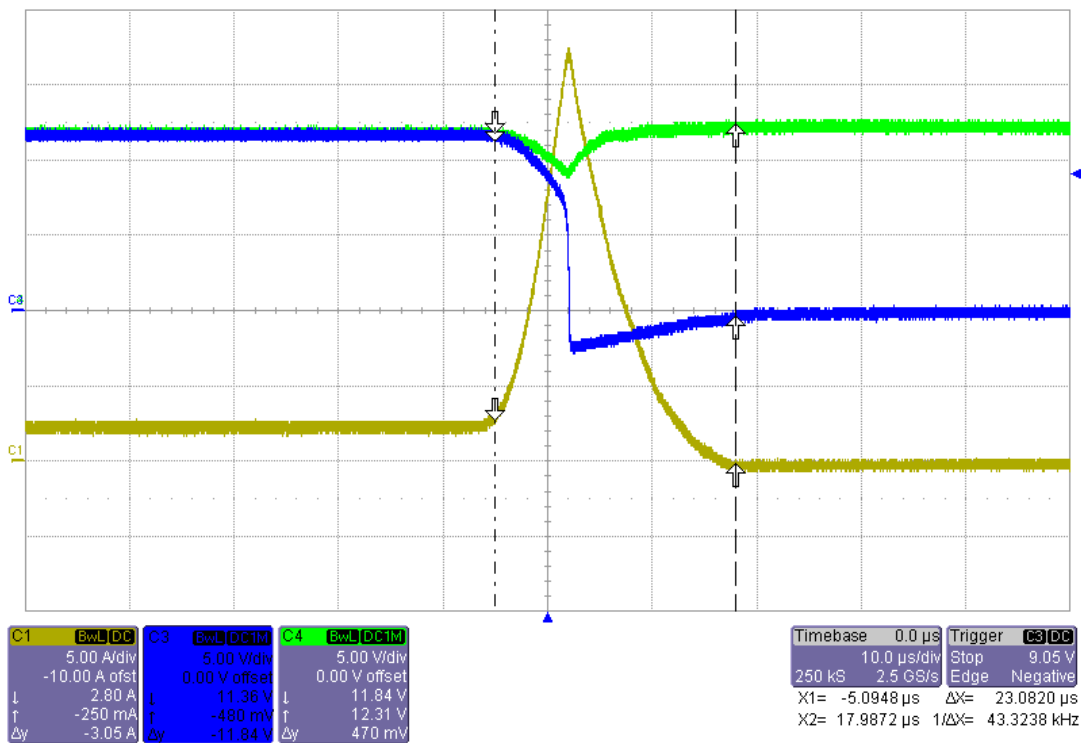

Figure 10. Load Switch Response to Short Circuit

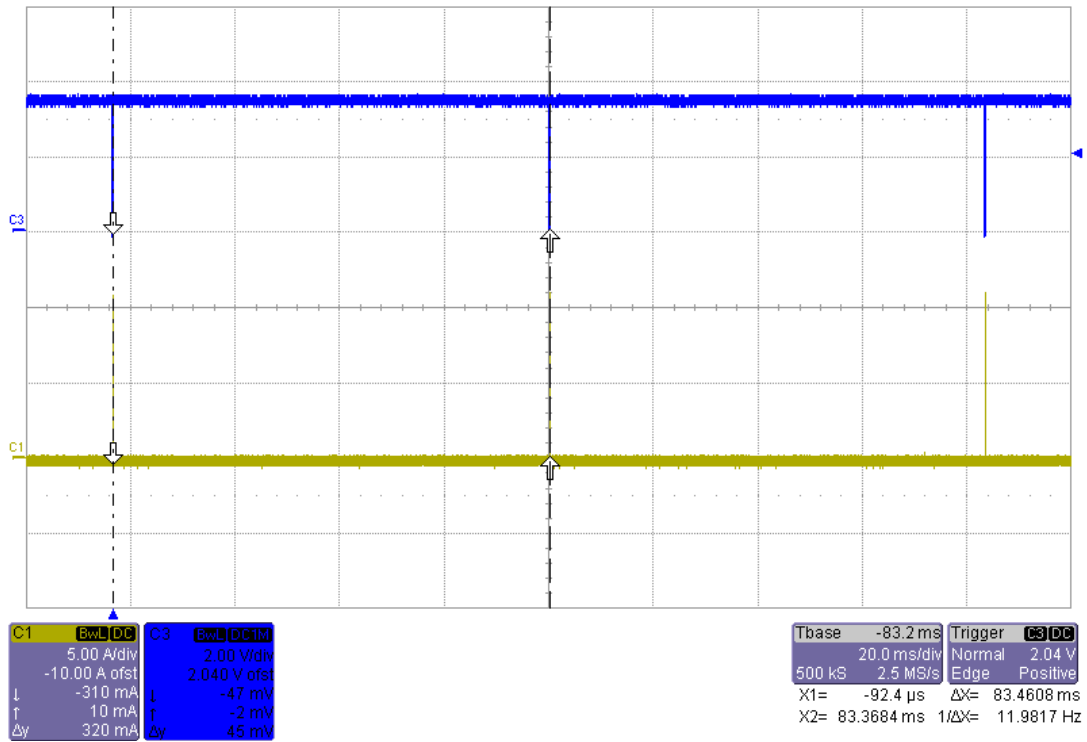

Figure 11. MSP430 Fast Trip Comparator Response to Load Short Circuit ( $\overline{EN}$ )

### Revision History

NOTE: Page numbers for previous revisions may differ from page numbers in the current version.

Changes from Original (October 2014) to A Revision

Page

## IMPORTANT NOTICE FOR TI DESIGN INFORMATION AND RESOURCES

Texas Instruments Incorporated ("TI") technical, application or other design advice, services or information, including, but not limited to, reference designs and materials relating to evaluation modules, (collectively, "TI Resources") are intended to assist designers who are developing applications that incorporate TI products; by downloading, accessing or using any particular TI Resource in any way, you (individually or, if you are acting on behalf of a company, your company) agree to use it solely for this purpose and subject to the terms of this Notice.

TI's provision of TI Resources does not expand or otherwise alter TI's applicable published warranties or warranty disclaimers for TI products, and no additional obligations or liabilities arise from TI providing such TI Resources. TI reserves the right to make corrections, enhancements, improvements and other changes to its TI Resources.

You understand and agree that you remain responsible for using your independent analysis, evaluation and judgment in designing your applications and that you have full and exclusive responsibility to assure the safety of your applications and compliance of your applications (and of all TI products used in or for your applications) with all applicable regulations, laws and other applicable requirements. You represent that, with respect to your applications, you have all the necessary expertise to create and implement safeguards that (1) anticipate dangerous consequences of failures, (2) monitor failures and their consequences, and (3) lessen the likelihood of failures that might cause harm and take appropriate actions. You agree that prior to using or distributing any applications that include TI products, you will thoroughly test such applications and the functionality of such TI products as used in such applications. TI has not conducted any testing other than that specifically described in the published documentation for a particular TI Resource.

You are authorized to use, copy and modify any individual TI Resource only in connection with the development of applications that include the TI product(s) identified in such TI Resource. NO OTHER LICENSE, EXPRESS OR IMPLIED, BY ESTOPPEL OR OTHERWISE TO ANY OTHER TI INTELLECTUAL PROPERTY RIGHT, AND NO LICENSE TO ANY TECHNOLOGY OR INTELLECTUAL PROPERTY RIGHT OF TI OR ANY THIRD PARTY IS GRANTED HEREIN, including but not limited to any patent right, copyright, mask work right, or other intellectual property right relating to any combination, machine, or process in which TI products or services are used. Information regarding or referencing third-party products or services does not constitute a license to use such products or services, or a warranty or endorsement thereof. Use of TI Resources may require a license from a third party under the patents or other intellectual property of the third party, or a license from TI under the patents or other intellectual property of TI.

TI RESOURCES ARE PROVIDED "AS IS" AND WITH ALL FAULTS. TI DISCLAIMS ALL OTHER WARRANTIES OR REPRESENTATIONS, EXPRESS OR IMPLIED, REGARDING TI RESOURCES OR USE THEREOF, INCLUDING BUT NOT LIMITED TO ACCURACY OR COMPLETENESS, TITLE, ANY EPIDEMIC FAILURE WARRANTY AND ANY IMPLIED WARRANTIES OF MERCHANTABILITY, FITNESS FOR A PARTICULAR PURPOSE, AND NON-INFRINGEMENT OF ANY THIRD PARTY INTELLECTUAL PROPERTY RIGHTS.

TI SHALL NOT BE LIABLE FOR AND SHALL NOT DEFEND OR INDEMNIFY YOU AGAINST ANY CLAIM, INCLUDING BUT NOT LIMITED TO ANY INFRINGEMENT CLAIM THAT RELATES TO OR IS BASED ON ANY COMBINATION OF PRODUCTS EVEN IF DESCRIBED IN TI RESOURCES OR OTHERWISE. IN NO EVENT SHALL TI BE LIABLE FOR ANY ACTUAL, DIRECT, SPECIAL, COLLATERAL, INDIRECT, PUNITIVE, INCIDENTAL, CONSEQUENTIAL OR EXEMPLARY DAMAGES IN CONNECTION WITH OR ARISING OUT OF TI RESOURCES OR USE THEREOF, AND REGARDLESS OF WHETHER TI HAS BEEN ADVISED OF THE POSSIBILITY OF SUCH DAMAGES.

You agree to fully indemnify TI and its representatives against any damages, costs, losses, and/or liabilities arising out of your non-compliance with the terms and provisions of this Notice.

This Notice applies to TI Resources. Additional terms apply to the use and purchase of certain types of materials, TI products and services. These include; without limitation, TI's standard terms for semiconductor products (<http://www.ti.com/sc/docs/stdterms.htm>), [evaluation modules](#), and [samples](http://www.ti.com/sc/docs/sampterm.htm) (<http://www.ti.com/sc/docs/sampterm.htm>).

Mailing Address: Texas Instruments, Post Office Box 655303, Dallas, Texas 75265  
Copyright © 2018, Texas Instruments Incorporated