

## **TPS65381EVM User's Guide**

The TPS65381EVM evaluation module (EVM) helps engineers evaluate the operation and performance of the TPS65381x-Q1 (TPS65381-Q1 or TPS65381A-Q1) multi-rail power supply for microcontrollers in safety relevant applications. This document describes how to setup and configure the EVM for operation. The document also includes the board layout, schematic, and bill of materials (BOM) for the EVM.

### **Contents**

1	Introduction .....	2
2	TPS65381x-Q1 Description .....	3
3	Schematic, Bill of Materials, and Layout.....	4
4	Setup and Operation .....	12
5	TIGER GUI Software .....	18

### **List of Figures**

1	EVM Top Board View .....	2
2	TPS65381EVM Schematic .....	4
3	EVM Top View .....	7
4	EVM Bottom View .....	8
5	Top Assembly Layer .....	9
6	Bottom Assembly Layer.....	9
7	Top Layer Routing .....	10
8	Layer 2 (AGND) Routing .....	10
9	Layer 3 Routing.....	11
10	Layer 4 Routing.....	11
11	WD Timing .....	15
12	Start-Up Screen .....	16
13	After Clicking IGN, Device Has Started, $I_q$ is About 30 mA, Device is in Diagnostic Mode .....	16
14	Clear ERR Fail and WD Fail Flags .....	17
15	Clear DIAG EXIT MASK = Device is in Active Mode.....	17
16	Set ENABLE_DRV and Read Back Pin Level ENDRV .....	18

### **List of Tables**

1	Device and Package Configurations .....	2
2	EVM Connectors .....	12
3	EVM Voltages.....	13
4	EVM Jumper .....	13
5	EVM Test Points.....	14

### **Trademarks**

PowerPAD is a trademark of Texas Instruments.

## 1 Introduction

The TPS65381EVM evaluation module (EVM) helps engineers evaluate the operation and performance of the TPS65381x-Q1 (TPS65381-Q1 or TPS65381A-Q1) multi-rail power supply for microcontrollers in safety relevant applications. The device is configurable through a serial peripheral interface (SPI) and specific input pins.

The EVM contains the TPS65381x-Q1 device and some circuitry for basic operation, see [Figure 1](#) for the top board view of the EVM. It has a connection for an optional TIGER board (not included) to configure the TPS65381x-Q1 device through the SPI. It can also be used with a microcontroller (MCU) board or other 3rd party SPI tool connected to the TPS65381EVM SPI connections.

**Table 1. Device and Package Configurations**

VERSION	Multi-Rail Power Supply	IC	PACKAGE
001	IC1	TPS65381QDAPRQ1	DAP-32
002	IC1	TPS65381AQDAPRQ1	DAP-32

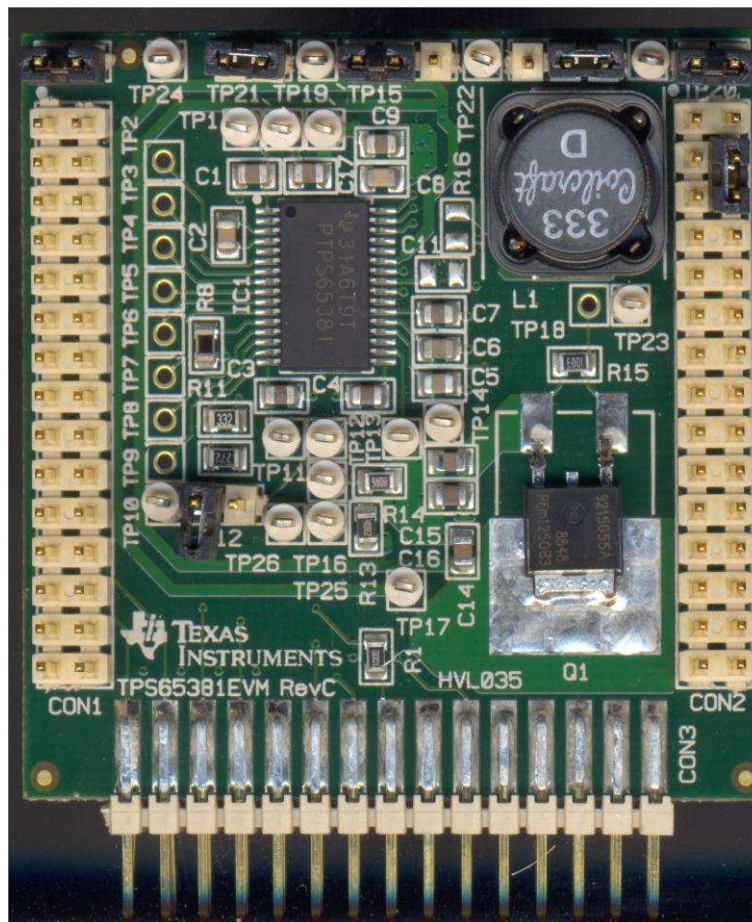

**Figure 1. EVM Top Board View**

## 2 TPS65381x-Q1 Description

The TPS65381x-Q1 device is a multi-rail power supply designed to supply microcontrollers (MCUs) in safety relevant applications, such as those found in automotive and industrial markets. The device supports Texas Instruments' Hercules™ TMS570 MCU and C2000™ families, and various other MCUs with dual-core lockstep (LS) or loosely-coupled architectures (LC).

The TPS65381x-Q1 device integrates multiple supply rails to power the MCU, Controller Area Network (CAN), or FlexRay, and an external sensor. An asynchronous buck switch mode power supply converter with an internal FET converts the input supply (battery) voltage to a 6-V preregulator output. This 6-V preregulator supplies the other regulators. The device supports wake-up from IGNITION or wake-up from the CAN transceiver.

The integrated fixed 5-V linear regulator with internal FET can be used for a CAN or FlexRay transceiver supply for example. A second linear regulator, also with an internal FET, regulates to a selectable 5-V or 3.3-V output which for example can be use for the MCU I/O voltage.

The TPS65381x-Q1 device includes an adjustable linear regulator controller, requiring an external FET and resistor divider, that regulates to an adjustable voltage of between 0.8 V and 3.3 V which may be used for the MCU core supply.

The integrated sensor supply can be run in tracking mode or adjustable output mode and includes short-to-ground and short-to-battery protection. Therefore, this regulator can power a sensor outside the module or electronic control unit (ECU).

The integrated charge pump to provides overdrive voltage for the internal regulators. The charge pump may also be used in a reverse-battery protection circuit by using the charge-pump output to control an external NMOS transistor. This solution allows for a lower minimum-battery-voltage operation compared to a traditional reverse-battery blocking diode when the device must be operational at the lowest possible supply voltages.

The device monitors undervoltage and overvoltage on all regulator outputs, battery voltage, and internal supply rails. A second bandgap reference, independent from the main bandgap reference, is used for the undervoltage and overvoltage monitoring, to avoid any drifts in the main bandgap reference from being undetected. In addition, regulator current-limits and temperature protections are implemented.

The TPS65381x-Q1 has monitoring and protection functions, which include the following: watchdog with trigger and *question and answer* modes, MCU error-signal monitor, clock monitoring on internal oscillators, self-check on the clock monitor, cyclic redundancy check (CRC) on non-volatile memory, a diagnostic output pin allowing the MCU to observe internal analog and digital signals of the device, a reset circuit and output pin for the MCU, and an enable drive output to disable the safing-path or external-power stages on detected faults. A built-in self-test (BIST) monitors the device functionality automatically at power-up. A dedicated DIAGNOSTIC state allows the MCU to check TPS65381x-Q1 monitoring and protection functions.

## 3 Schematic, Bill of Materials, and Layout

### 3.1 Schematic

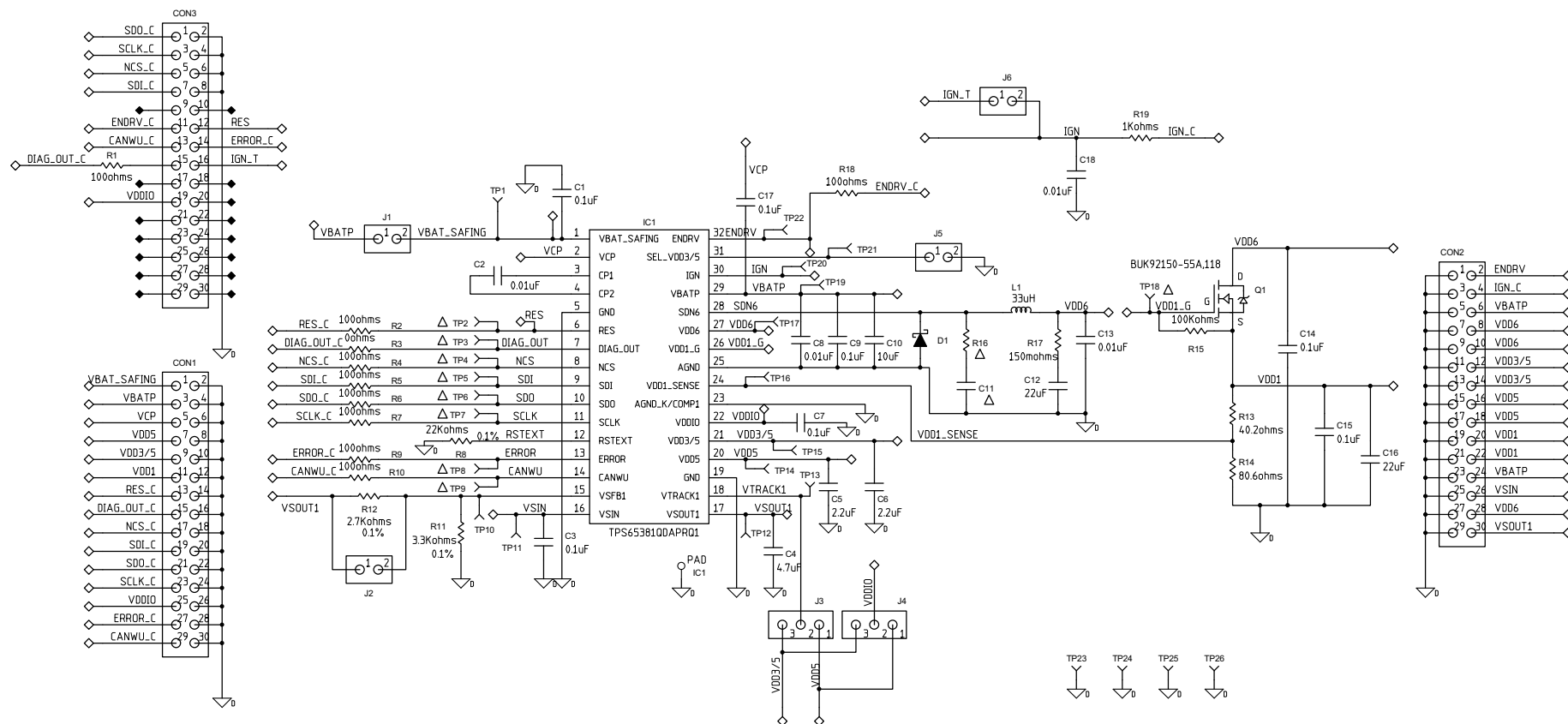

Version 001 shown for TPS65381-Q1. Version 002 is for TPS65381A-Q1.

R16 and C11 can be populated to bring the effective capacitance for VDD6 output higher. See datasheet for  $C_{VDD6}$  requirements in the parametric section and see the VDD6 Pre-regulator section on how to choose L, R and C to balance operation of VDD6.

**Figure 2. TPS65381EVM Schematic**

### 3.2 Bill of Materials

ITEM	QTY (001)	QTY (002)	MFG	MFG PART NO.	REF DES	DESCRIPTION	VALUE or FUNCTION
	REF	REF	-	-C	-	ASSEMBLY	-
	REF	REF	-	-C	-	SCHEMATIC	-
	1	1	-	-C	-	FABRICATION	-
	REF	REF	-	-C	-	ARTWORK	-
	1	1	Any	HLV035	PCB	Printed Circuit Board	SIZE 50.35 x 50 x 1.5 mm
1	0	0	UNINSTALLED	CAP_0805 (UN)	C11		UNINSTALLED CAP0805
2	4	4	SULLINS	PEC02SAAN	J1, J2, J5, J6		HEADER, THU, 1 x 2, 2.54 mm
3	2	2	SULLINS	PEC03SAAN	J3, J4		HEADER, THU, 1 x 3, 2.54 mm
4	3	3	SULLINS	PEC15DAAN	CON1, CON2, CON3		HEADER, THU, 2 x 15, 2.54 mm
5	0	0	UNINSTALLED	RES_0805 (UN)	R16		UNINSTALLED RES0805
6	3	3	AVX	08051C103JAT2A	C8, C13, C18	CAP, SMT, 0805	CAPACITOR, SMT, 0805, CERAMIC, 0.01 $\mu$ F, 100 V, 5%, X7R
7	7	7	AVX	08055C104KAT2A	C1, C3, C7, C9, C14, C15, C17	CAP, SMT, 0805	CAPACITOR, SMT, 0805, CERAMIC, 0.1 $\mu$ F, 50 V, 10%, X7R
8	1	1	KEMET	C0805C103K5RAC	C2	CAP, SMT, 0805	CAPACITOR, SMT, 0805, CER, 0.01 $\mu$ F, 50 V, 10%, X7R
9	1	1	MURATA	GRM21BR60J226ME39L	C16	CAP, SMT, 0805	CAPACITOR, SMT, 0805, CERAMIC, 22 $\mu$ F, 6.3 V, 20%, X5R
10	2	2	MURATA	GRM21BR71C225KA12L	C5, C6	CAP, SMT, 0805	CAPACITOR, SMT, 0805, CERAMIC, 2.2 $\mu$ F, 16 V, 10%, X7R
11	1	1	MURATA	GRM21BR71C475KA73L	C4	CAP, SMT, 0805	CAPACITOR, SMT, 0805, CERAMIC, 4.7 $\mu$ F, 16 V, 10%, X7R
12	1	1	MURATA	GRM31CR61C226ME15L	C12	CAP, SMT, 1206	CAPACITOR, SMT, 1206, CER, 22 $\mu$ F, 16 V, 20%, X5R
13	1	1	TDK	C3216X5R1H106K	C10	CAPACITOR, SMT1206	CAPACITOR, SMT, 1206, CERAMIC, 10 $\mu$ F, 50 V, 10%, X5R
14	1	1	ON SEMI	MBRS340T3G	D1	DIODE, SMT, SMC-2	SCHOTTKY DIODE, SMT, 40 V, 3 A
15	1	1	PHILIPS	BUK92150-55A,118	Q1	DKPAK, SOT428	N-CHANNEL TRENCHMOS DPAK
16	1	0	TI	TPS65381QDAPRQ1 or TPS65381AQDAPRQ1	IC1	IC, SMT, HTSSOP-32	DUT, SMT, HTSSOP, 32DAP, 0.65 mmLS, 11.1 x 8.3 x 1.2 mm, THERMAL PAD
17	1	1	COILCRAFT	MSS1246T-333ML	L1	INDUCTOR, SMT, 2P	INDUCTOR, SMT, 33 $\mu$ H, 20%, 3.6 A, SHIELD
18	1	1	VISHAY	CRCW08050000Z	R3	RES, SMT, 0805	RESISTOR, SMT, 0805, THICK FILM, 1/8 W, 0 $\Omega$

ITEM	QTY (001)	QTY (002)	MFG	MFG PART NO.	REF DES	DESCRIPTION	VALUE or FUNCTION
19	1	1	VISHAY	CRCW0805100KF	R15	RES, SMT, 0805	RESISTOR, SMT, 0805, THICK FILM, 1%, 1/8 W, 100K
20	9	9	VISHAY	CRCW0805100RF	R1, R2, R4, R5, R6, R7, R9, R10, R18	RES, SMT, 0805	RESISTOR, SMT, 0805, THICK FILM, 1%, 1/8 W, 100 $\Omega$
21	1	1	VISHAY	CRCW08051K00F	R19	RES, SMT, 0805	RESISTOR, SMT, 0805, THICK FILM, 1%, 1/8 W, 1.00K
22	1	1	VISHAY	CRCW080540R2F	R13	RES, SMT, 0805	RESISTOR, SMT, 0805, THICK FILM, 1%, 1/8 W, 40.2 $\Omega$
23	1	1	VISHAY	CRCW080580R6F	R14	RES, SMT, 0805	RESISTOR, SMT, 0805, THICK FILM, 1%, 1/8 W, 80.6 $\Omega$
24	1	1	PANASONIC	ERJ-6RSJR15V	R17	RES, SMT, 0805	RESISTOR, SMT, 0805, 0.15 $\Omega$ , 5%, 1/8 W
25	1	1	PANASONIC	ERA-6YEB223V	R8	RES, SMT, 2P	RESISTOR, SMT, 0805, 22K, 0.1%, 1/10 W, 25 ppm
26	1	1	PANASONIC	ERA-6YEB272V	R12	RES, SMT, 2P	RESISTOR, SMT, 0805, 2.7K, 0.1%, 1/10 W, 25 ppm
27	1	1	PANASONIC	ERA-6YEB332V	R11	RES, SMT, 2P	RESISTOR, SMT, 0805, 3.3K, 0.1%, 1/10 W, 25 ppm
28	17	17	KEYSTONE	5002	TP1, TP10, TP11, TP12, TP13, TP14, TP15, TP16, TP17, TP19, TP20, TP21, TP22, TP23, TP24, TP25, TP26	TESTPOINT, THU, 1P	TESTPOINT, THU, MINIATURE, 0.1LS, 120TL, WHITE
29	0	0	KEYSTONE	5002 (UN)	TP2, TP3, TP4, TP5, TP6, TP7, TP8, TP9, TP18	TESTPOINT, THU, 1P	UNINSTALLED TESTPOINT, THU, MINIATURE, 0.1LS, 120TL, WHITE
30	6	6	FISCHER	CAB 4 G S	J1, J2, J3, J4, J5, J6	2.54 mm JUMPER	2.54 mm JUMPER



### 3.3 Layout and Component Placement

#### 3.3.1 Top View

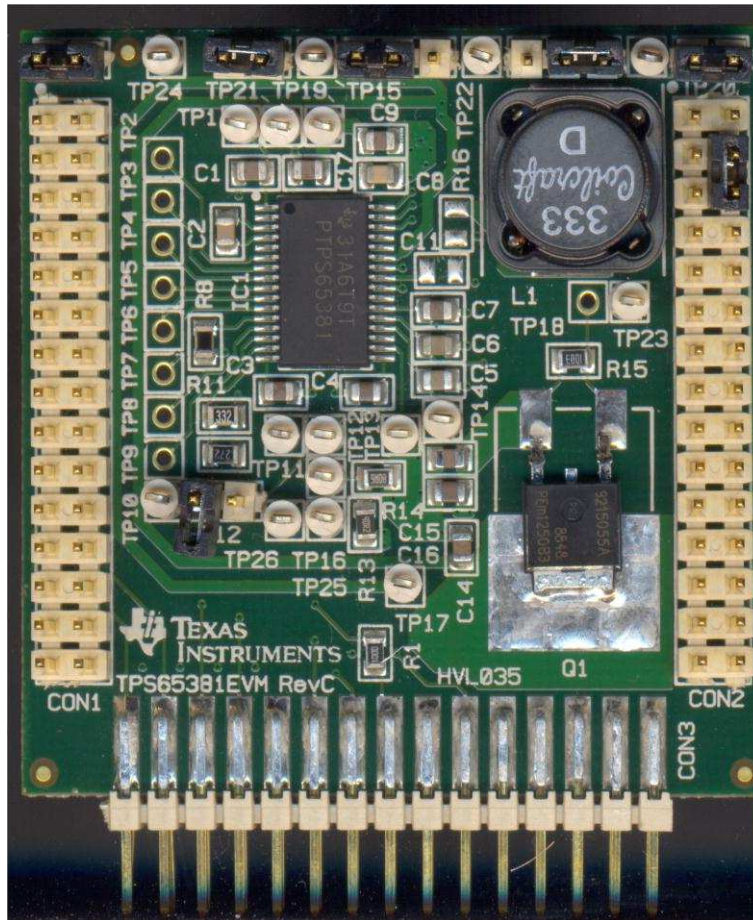
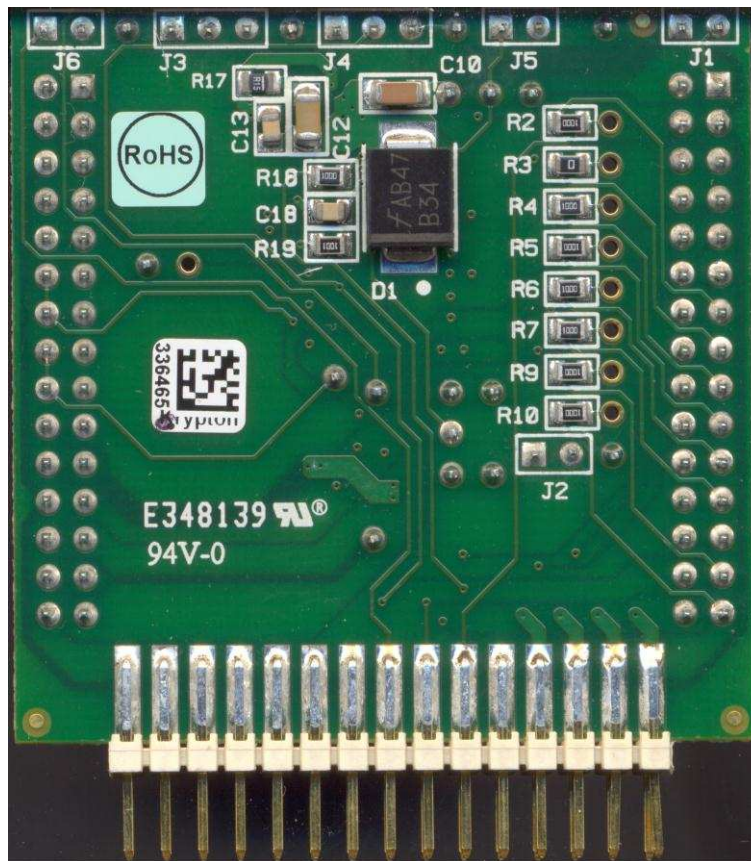

Figure 3. EVM Top View

### 3.3.2 Bottom View



**Figure 4. EVM Bottom View**

### 3.3.3 Board Assembly

Figure 2 shows the EVM schematic. Figure 3 and Figure 4 show photos of the EVM. Figure 5 and Figure 6 show the board assembly layers.

While the TPS65381x-Q1 converter offers high efficiency, there may still be high power dissipation. The power dissipation will vary depending on input supply voltage, output voltages programmed on the various rails and load currents. The PowerPAD™ package offers an exposed thermal pad to enhance thermal performance which must be soldered to the copper landing on the PCB for optimal performance. The EVM PCB provides 2 oz. copper planes on the top and bottom to dissipate heat. Power dissipation and thermal analysis should be done to ensure the thermal management and design for each specific application and PCB design.



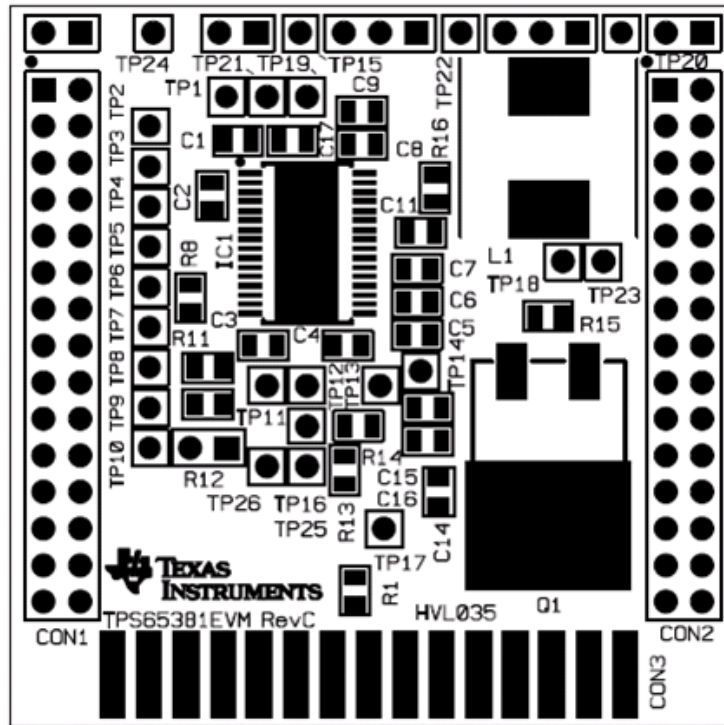

Figure 5. Top Assembly Layer

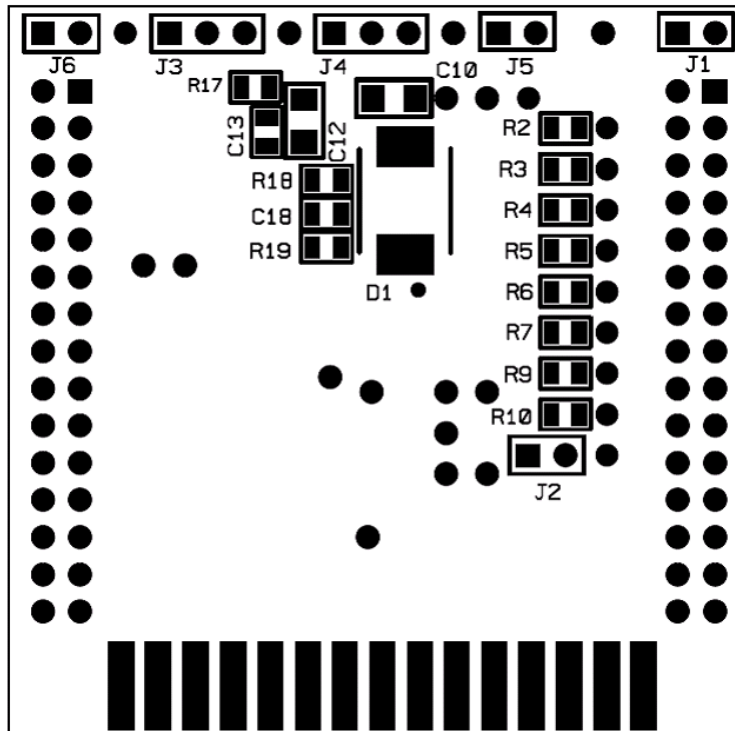

Figure 6. Bottom Assembly Layer

### 3.3.4 Board Layout

Figure 7 through Figure 10 show the board layout.

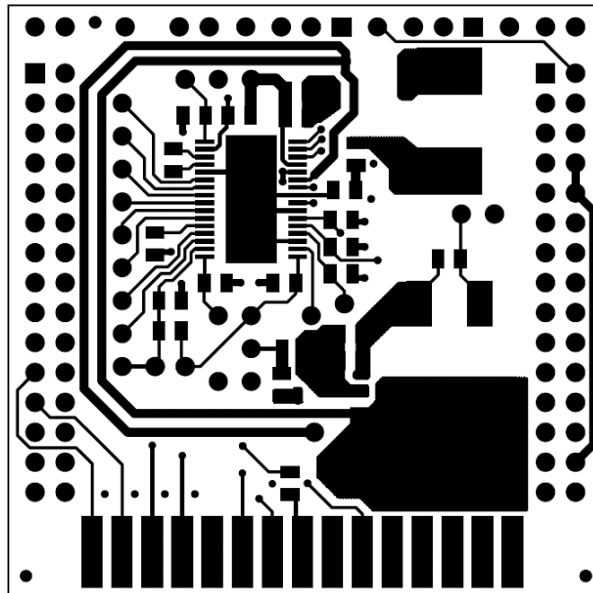

Figure 7. Top Layer Routing

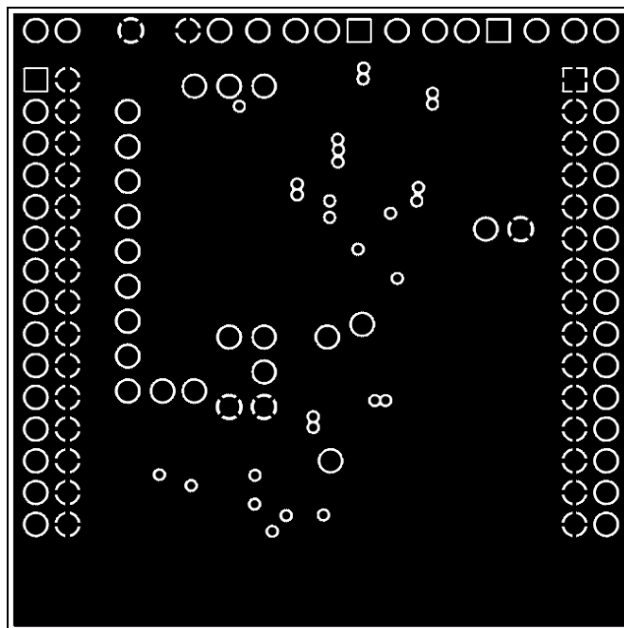

Figure 8. Layer 2 (AGND) Routing

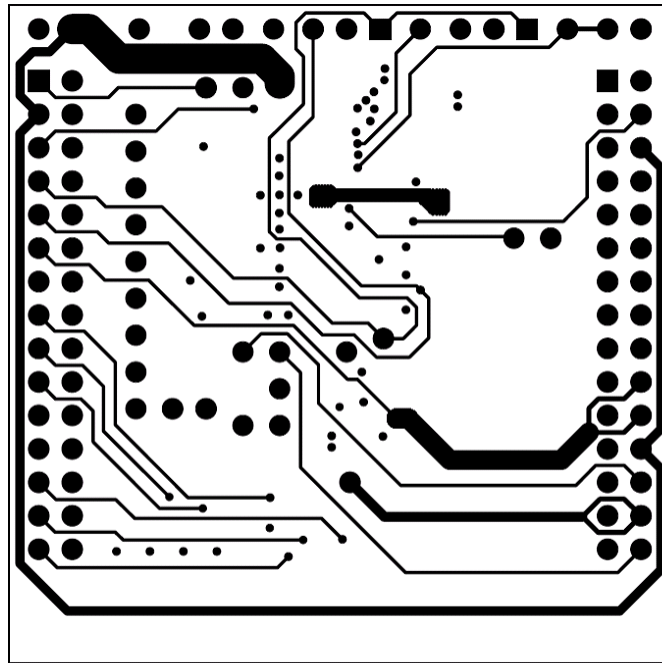

Figure 9. Layer 3 Routing

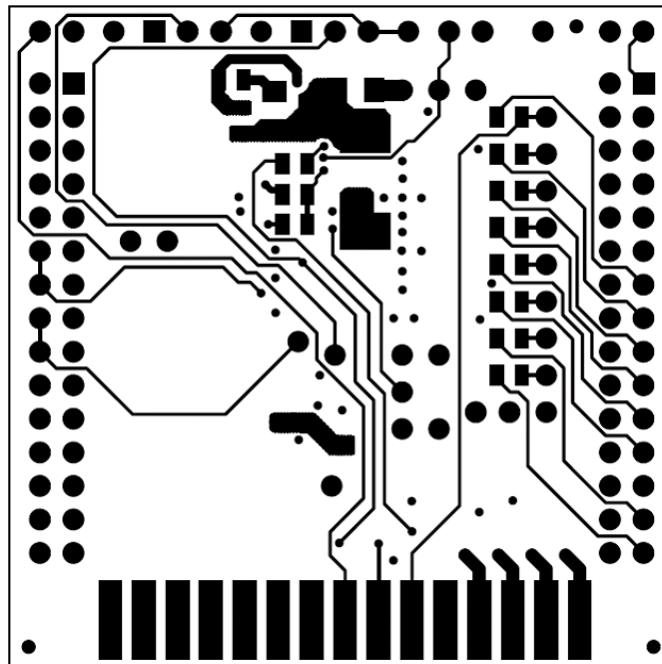

Figure 10. Layer 4 Routing

## 4 Setup and Operation

This section describes the jumpers and connectors on the EVM and how to properly connect, set up and use the TPS65381EVM.

### 4.1 I/O Connector Description

Three connectors are placed to supply the device under test (DUT) to get access to different signals for programming or to measure.

CON1 is the supply connector to provide the battery voltage and offer a connection to SPI.

CON2 is the output connector to deliver the output voltage of the different regulators.

CON3 is a connector to either the SPI of an application circuit, or the optional TIGER board which provides a universal serial bus (USB) to SPI connection.

**Table 2. EVM Connectors**

CON1		CON2		CON3	
PIN NO.	SIGNALS	PIN NO.	SIGNALS	PIN NO.	SIGNALS
1	VBAT_SAFING	1	GND	1	SDO
2	GND	2	ENDRV	2	GND
3	VBATP	3	GND	3	SCLK
4	GND	4	IGN	4	GND
5	VCP	5	GND	5	NCS
6	GND	6	VBATP	6	GND
7	VDD5	7	GND	7	SDI
8	GND	8	VDD6	8	GND
9	VDD3/5	9	GND	9	Open
10	GND	10	VDD6	10	Open
11	VDD1	11	GND	11	ENDRV
12	GND	12	VDD3/5	12	RES
13	RES	13	GND	13	CANWU
14	GND	14	VDD3/5	14	ERROR
15	DIAG_OUT	15	GND	15	DIAGOUT
16	GND	16	VDD5	16	IGN
17	NCS	17	GND	17	Open
18	GND	18	VDD5	18	Open
19	SDI	19	GND	19	VDDIO
20	GND	20	VDD1	20	Open
21	SDO	21	GND	21	Open
22	GND	22	VDD1	22	Open
23	SCLK	23	GND	23	Open
24	GND	24	VBATP	24	Open
25	VDDIO	25	GND	25	Open
26	GND	26	VSIN	26	Open
27	ERROR	27	GND	27	Open
28	GND	28	VDD6	28	Open
29	CANWU	29	GND	29	Open
30	GND	30	VSOUT1	30	Open

## 4.2 Supply

The input voltage range for the converter is  $VBATP = VBAT\_SAFING = 5.8$  volts to 36 volts. It should be supplied to CON1, pin 1 (VBAT\_SAFING) and 3 (VBATP) with respect to pin 2 and 4 (GND).

**NOTE:**  $VBATP = VBAT\_SAFING$  may be lowered to 4.5 volts after the device has been powered up, but VDD6 will be in dropout mode (100% duty) cycle, VDD5 will be in dropout and VDD3/5 will be in dropout and may cause RESET state if configured to 5 V mode depending on the detected output voltage, it will be operational if used in 3.3V mode.

**Table 3. EVM Voltages**

PARAMETER	TEST CONDITIONS	CONx CONNECTOR	PIN	MIN	TYP	MAX	UNIT
VBATP	Can be connected to VBAT_SAFING by placing J1	1	3	5.8	14	36	V
VBAT_SAFING	Can be connected to VBAT_P by placing J1	1	1	5.8	14	36	V
VDD6		2	8, 10	5.4	6	6.6	V
VDD1		2	20, 22	0.8	1.2	3.3	V
VDD3/5		2	12, 14	3.23 / 4.9	3 / 5	3.36 / 5.1	V
VDD5		2	16, 18	4.9	5	5.1	V
VSOUT1		2	30	3.3	5	9.5	V
VDDIO		1	25	3.3		5	V

## 4.3 Jumper Setting

For proper operation of the TPS65381x-Q1 device, the jumpers should be properly configured. The recommended setting is shown in the table below.

**Table 4. EVM Jumper<sup>(1)</sup>**

J NO.	DESCRIPTION	OPTION	STANDARD
J1	Connect VBAT_SAFING to VBATP.	Open and supply VBAT_SAFING with separate supply voltage.	Set
J2	Use VSOUT1 as follower or with gain.	Open VSOUT1 has gain defined by R11 and R12. Set is VSOUT1 is follower.	Open
J3	Select the tracking input.	Open for non-tracking mode or connect to VDD3/5 or VDD5 for tracking mode.	Open
J4	Select the VDDIO voltage.	Connect to VDD3/5 or VDD5.	VDD5
J5	Select output voltage VDD3/5.	Open VDD3/5 = 3.3 V. Set VDD3/5 = 5 V.	Set
J6	IGN supported by TIGER board and SPI connector CON3.	Open is not supported by SPI. Closed can be supported by SPI.	Open
CON2, pin 4	Connector 2 (pin 4) is the IGN pin; must be connected to CON2, pin 4 to turn the DUT on.	Remove the jumper to use the EVM together with TIGER board.	Set

<sup>(1)</sup> For start-up without using the TIGER board or external IGN signal, IGN (pin 4 of CON2) can be connected to VBATP (pin 6 of CON2) by setting a jumper to start up the device.



## 4.4 Test Points

Test points are placed to measure different nodes on the board.

**Table 5. EVM Test Points**

NO.	TEST POINT
1	VBAT_SAFING
2	RES
3	DIAG_OUT
4	NCS
5	SDI
6	SDO
7	SCLK
8	ERROR
9	CANWU
10	VSOUT1
11	VSIN
12	VSOUT1
13	VTRACK1
14	VDD5
15	VDD3/5
16	VDD1_SENSE
17	VDD6
18	VDD1_G
19	VBATP
20	IGN
21	SEL_VDD3/5
22	ENDRV

## 4.5 VDD6 Voltage Preregulator

The VDD6 preregulator is supplied by VBATP. Blocking capacitors C8, C9 and C10 are connected from VBATP to GND, stabilizing the input supply voltage. For long supply cables, additional higher capacitance capacitors could be helpful. The node SDN6 is the switching node of the buck converter. L1 is the inductor connected to SDN6 and VDD6. The freewheeling diode D1 allows current flow when the device internal high-side transistor is turned off. C11 and C12 are the output capacitors of the VDD6 regulator. R16 is the ESR of C11 and R17 is the ESR of C12 required for stability. C13 is a filter capacitor against high frequencies.

---

**NOTE:** VDD6 output capacitance requires controlled ESR. See the device datasheet electrical parameters and VDD6 Preregulator section for details on R, L and C choices to ensure stable and balanced operation of VDD6.

---

The VDD6 pin is the feedback line to close the control loop of the VDD6 regulator, and is also the supply node for the VDD3/5 and VDD5 regulators. The output voltage VDD6 is available at CON2, pins 8 and 10.

## 4.6 VDD1 Voltage Regulator (LDO Controller requiring external FET)

The VDD1 regulator has an internal control amplifier and an external NMOS power transistor. The regulator is supplied externally by VDD6. C14 stabilizes the input voltage of the VDD1 regulator. The voltage dividers R13 and R14 define the output voltage and close the control loop to VDD1\_SENSE. Additionally, a minimum required current flows through both resistors. The output capacitors C15 and C16 are needed to stabilize the control loop. The output voltage VDD1 is available at CON1, pin 11, and CON2, pins 20 and 22.

#### 4.7 VDD3/5 Voltage Regulator

The VDD3/5 regulator is supplied internally by VDD6. SEL\_VDD3/5 can select the output voltage. If the pin is open, 3.3 V is selected. If the pin is shorted to GND, 5 V is selected. The output capacitor C6 is needed to stabilize the output voltage. The output voltage VDD3/5 is available at CON1, pin 9, and CON2, pins 12 and 14.

#### 4.8 VDD5 Voltage Regulator

The VDD5 regulator is supplied internally by VDD6. The output capacitor C5 is needed to stabilize the output voltage. The output voltage VDD5 is available at CON1, pin 7, and CON2, pins 16 and 18.

#### 4.9 VSOUT1 Voltage Regulator

VSIN is the supply pin of VSOUT1 voltage regulator. If VSIN is connected to VDD6, lower power dissipation can be achieved. VSIN is supplied by VDD6 by placing a jumper to short pin 26 and 28 of CON2. If VSIN is connected to VBATP, output voltages higher than 5V are possible at the expense of higher power dissipation. To supply VSIN from VBATP, place a jumper to short pin 24 and 26 of CON2. The capacitor C3 stabilizes the input voltage. The voltage regulator can be used in tracking or non-tracking mode. Additionally, the voltage dividers R11 and R12 are used to define the output voltage. The capacitor C4 is needed for stable operation. The output voltage VSOUT1 is available at CON2, pin 30.

### 4.10 Operation

#### 4.10.1 Go into ACTIVE Mode - Step by Step Description

To go into active mode several steps are needed, please refer to the data sheet [SLVSB4](#).

1. Install the GUI software on a Windows PC.
2. Connect the EVM with the TIGER board, and the TIGER board to a PC USB connector.
3. Provide power to the EVM by connecting VBATP and VBAT\_SAFING to a 12-V power supply. Observe the quiescent current, it should be low since the device will be in STANDBY state unless IGN or CANWU has been pulled high.
4. Drive the watchdog (WD) with  $t = 74\text{ ms}$ ,  $t_{\text{high}} = 1\%$ , (to match default setting for watchdog) on CON 1 pin 27 (ERROR). The values can be changed but the TPS65381x-Q1 watchdog settings must also be updated to match the changed trigger pulse waveform. (see [SLVSB4](#)).

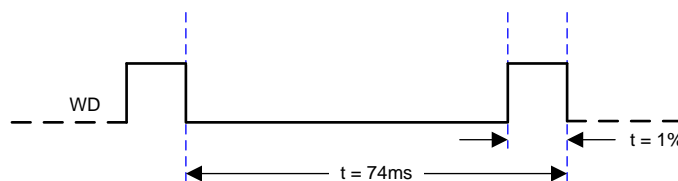

**Figure 11. WD Timing**

5. Start the GUI software.

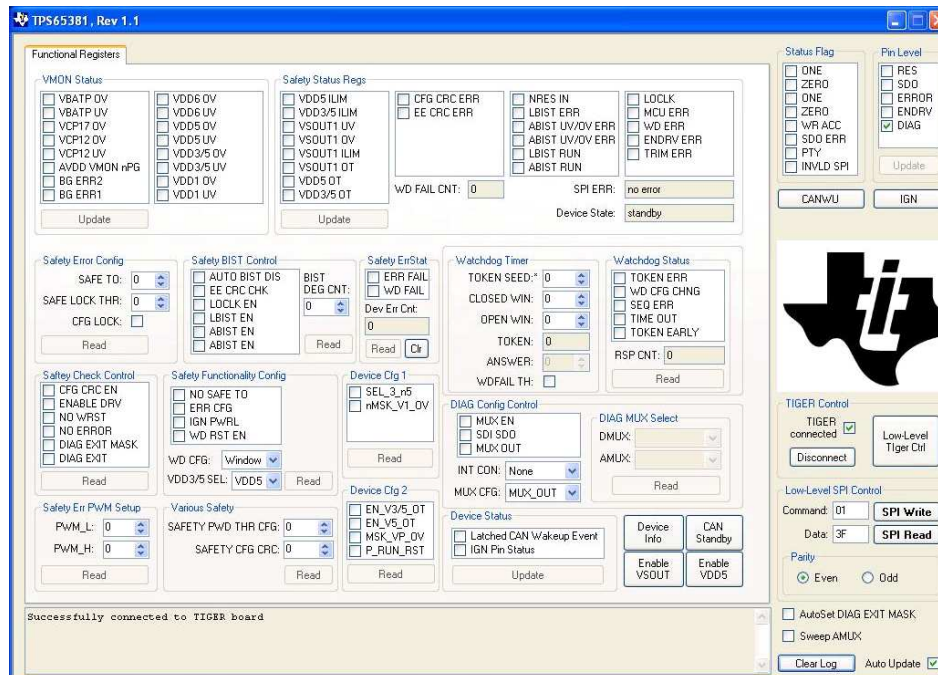

Figure 12. Start-Up Screen

6. Click the "AutoSet DIAG EXIT MASK" box in the lower right to "set" this function in the GUI. Setting this in the GUI causes the GUI to set the DIAG\_EXIT\_MASK bit before the device will have DIAGNOSTIC state timeout when the device is powered up by the IGN or CANWU button. Not doing so will cause the device to end up in SAFE state due to the non-real time nature of the GUI while the TPS65381x-Q1 is running in real time.
7. To wake up the device, click the IGN button.

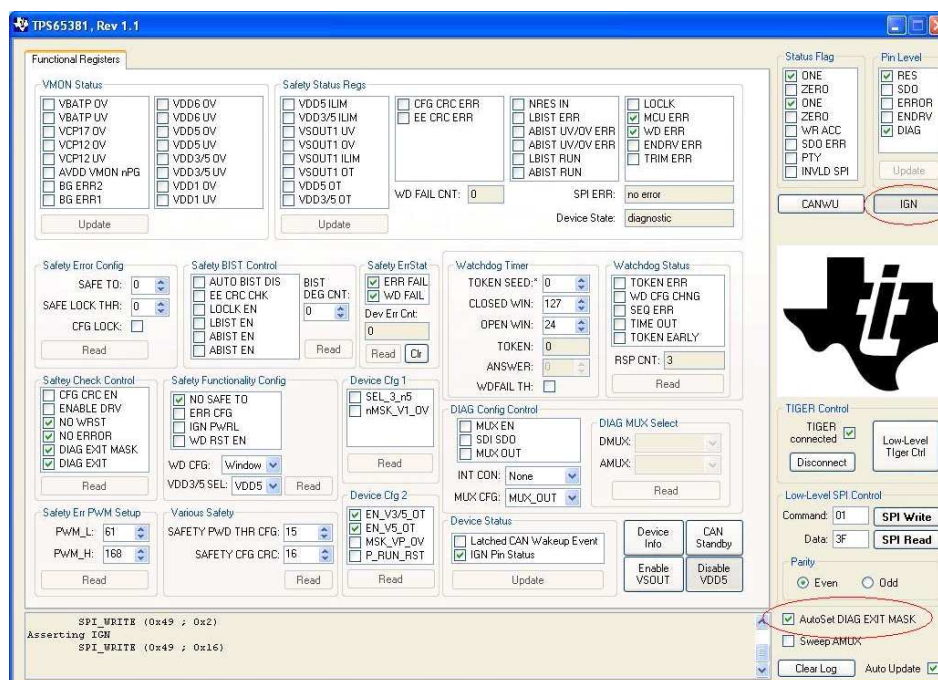

Figure 13. After Clicking IGN, Device Has Started, I<sub>q</sub> is About 30 mA, Device is in Diagnostic Mode

- Click the Clr button below ERR Fail and WD Fail to clear these flags and allow the device to go ACTIVE state.

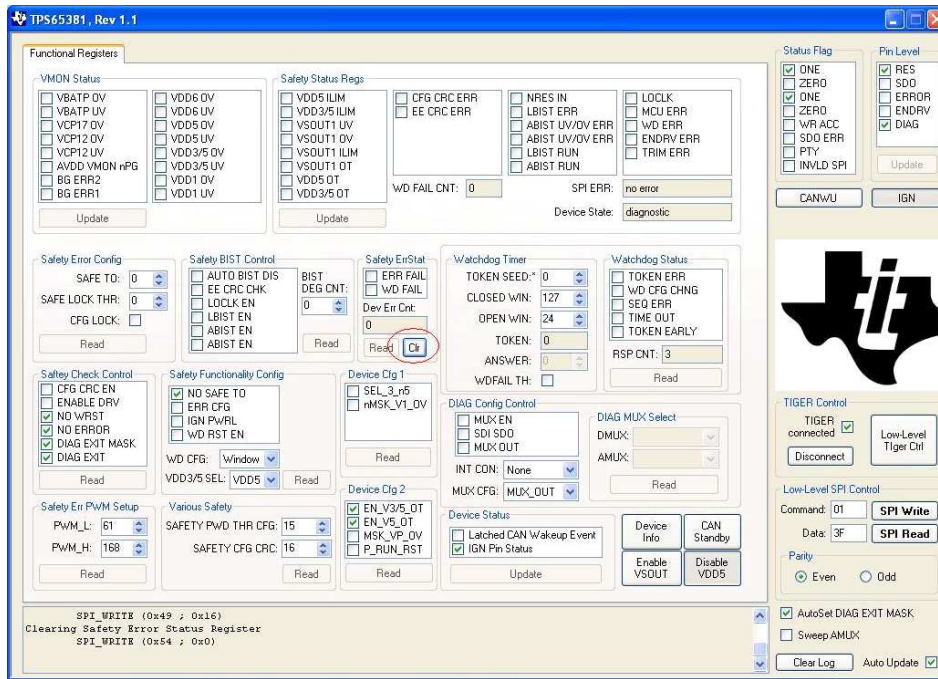

Figure 14. Clear ERR Fail and WD Fail Flags

- Click on the box for DIAG EXIT MASK to clear it and thus the control bit in the device. Once this bit is cleared the device will transition to ACTIVE state.

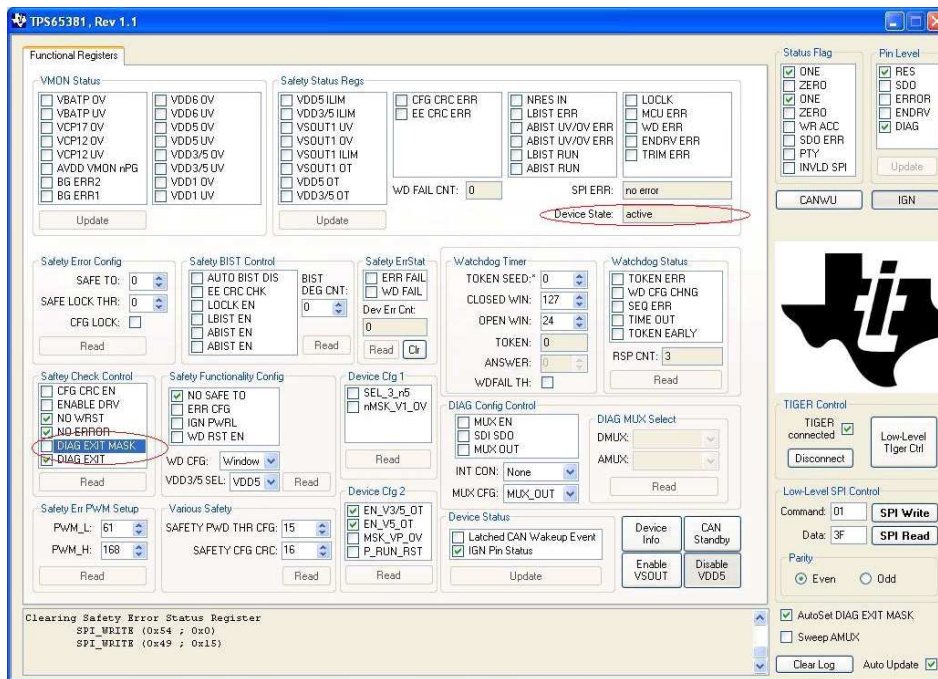
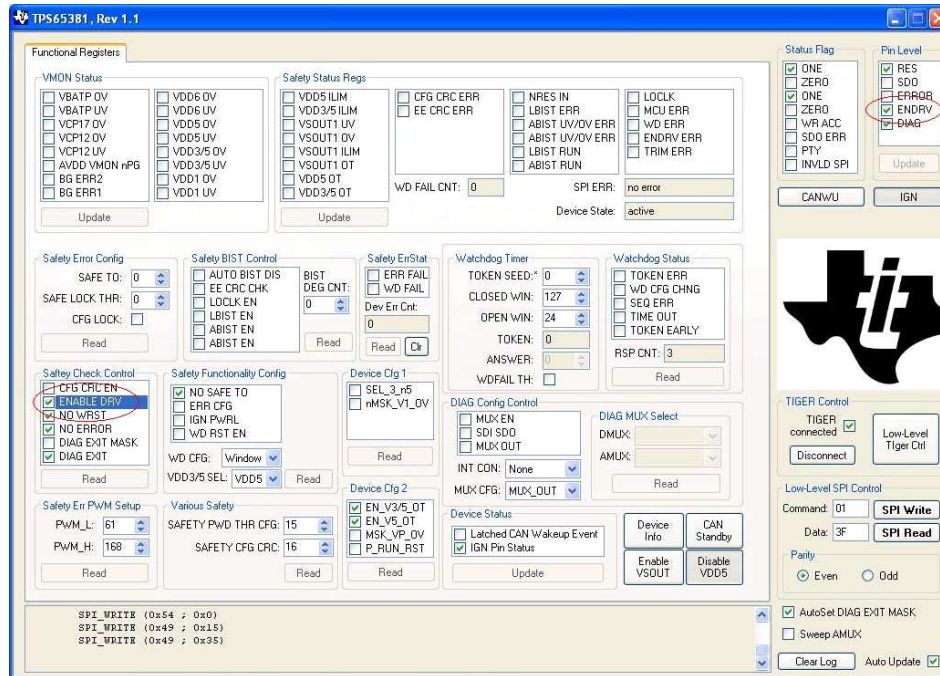

Figure 15. Clear DIAG EXIT MASK = Device is in Active Mode



- Click the box next to ENABLE\_DRV, middle left in the GUI, to set the bit in the device. Because the external signal on the EVM ERROR pin is connected to the device ERROR/WDI pin and the trigger pulse matches the configuration of the watchdog in trigger mode the WD\_FAIL\_CNT has been decremented to 0. Once ENABLE\_DRV is set, ENDRV pin will go high and this will be shown by the GUI in the upper right because the conditions allowing ENDRV to be high have been met.



**Figure 16. Set ENABLE\_DRV and Read Back Pin Level ENDRV**

Now the device is in active mode and the ENDRV signal would have enabled the power stages in a real safety relevant application.

For details regarding the flags and register setting, please refer to the data sheet ([SLVSB4](#)).

## 5 TIGER GUI Software

The graphical user interface (GUI) software is intended to support a quick start of the TPS65381x-Q1 evaluation. As the USB to SPI connection, a TIGER board is needed to run the software. It can be connected directly to CON3.

After first starting the software, the installation of a .net environment might be needed. It can be downloaded at [microsoft.com](#).

The software provides the user a GUI for easy set-up and control of the TPS65381x-Q1 device.

## Revision History

NOTE: Page numbers for previous revisions may differ from page numbers in the current version.

Changes from Original (April 2013) to A Revision	Page
• Changed document format to TI standards.....	1
• Added TPS65381(A)-Q1 device information.....	1
• Added EVM board photo to <i>Introduction</i> section.....	2
• Moved <i>Schematic, Board Picture, Board Assembly, Board Layout, and Bill of Material</i> sections to new <i>Schematic, Bill of Materials, and Layout</i> section .....	4
• Added TPS65381AQDAPRQ1 to the BOM.....	5
• Moved <i>TIGER GUI Software</i> to after <i>Setup and Operation</i> section.....	18



## STANDARD TERMS FOR EVALUATION MODULES

1. *Delivery:* TI delivers TI evaluation boards, kits, or modules, including any accompanying demonstration software, components, and/or documentation which may be provided together or separately (collectively, an "EVM" or "EVMs") to the User ("User") in accordance with the terms set forth herein. User's acceptance of the EVM is expressly subject to the following terms.
  - 1.1 EVMs are intended solely for product or software developers for use in a research and development setting to facilitate feasibility evaluation, experimentation, or scientific analysis of TI semiconductor products. EVMs have no direct function and are not finished products. EVMs shall not be directly or indirectly assembled as a part or subassembly in any finished product. For clarification, any software or software tools provided with the EVM ("Software") shall not be subject to the terms and conditions set forth herein but rather shall be subject to the applicable terms that accompany such Software
  - 1.2 EVMs are not intended for consumer or household use. EVMs may not be sold, sublicensed, leased, rented, loaned, assigned, or otherwise distributed for commercial purposes by Users, in whole or in part, or used in any finished product or production system.
2. *Limited Warranty and Related Remedies/Disclaimers:*
  - 2.1 These terms do not apply to Software. The warranty, if any, for Software is covered in the applicable Software License Agreement.
  - 2.2 TI warrants that the TI EVM will conform to TI's published specifications for ninety (90) days after the date TI delivers such EVM to User. Notwithstanding the foregoing, TI shall not be liable for a nonconforming EVM if (a) the nonconformity was caused by neglect, misuse or mistreatment by an entity other than TI, including improper installation or testing, or for any EVMs that have been altered or modified in any way by an entity other than TI, (b) the nonconformity resulted from User's design, specifications or instructions for such EVMs or improper system design, or (c) User has not paid on time. Testing and other quality control techniques are used to the extent TI deems necessary. TI does not test all parameters of each EVM. User's claims against TI under this Section 2 are void if User fails to notify TI of any apparent defects in the EVMs within ten (10) business days after delivery, or of any hidden defects with ten (10) business days after the defect has been detected.
  - 2.3 TI's sole liability shall be at its option to repair or replace EVMs that fail to conform to the warranty set forth above, or credit User's account for such EVM. TI's liability under this warranty shall be limited to EVMs that are returned during the warranty period to the address designated by TI and that are determined by TI not to conform to such warranty. If TI elects to repair or replace such EVM, TI shall have a reasonable time to repair such EVM or provide replacements. Repaired EVMs shall be warranted for the remainder of the original warranty period. Replaced EVMs shall be warranted for a new full ninety (90) day warranty period.
3. *Regulatory Notices:*
  - 3.1 *United States*
    - 3.1.1 *Notice applicable to EVMs not FCC-Approved:*

**FCC NOTICE:** This kit is designed to allow product developers to evaluate electronic components, circuitry, or software associated with the kit to determine whether to incorporate such items in a finished product and software developers to write software applications for use with the end product. This kit is not a finished product and when assembled may not be resold or otherwise marketed unless all required FCC equipment authorizations are first obtained. Operation is subject to the condition that this product not cause harmful interference to licensed radio stations and that this product accept harmful interference. Unless the assembled kit is designed to operate under part 15, part 18 or part 95 of this chapter, the operator of the kit must operate under the authority of an FCC license holder or must secure an experimental authorization under part 5 of this chapter.
    - 3.1.2 *For EVMs annotated as FCC – FEDERAL COMMUNICATIONS COMMISSION Part 15 Compliant:*

### CAUTION

This device complies with part 15 of the FCC Rules. Operation is subject to the following two conditions: (1) This device may not cause harmful interference, and (2) this device must accept any interference received, including interference that may cause undesired operation.

Changes or modifications not expressly approved by the party responsible for compliance could void the user's authority to operate the equipment.

### FCC Interference Statement for Class A EVM devices

*NOTE: This equipment has been tested and found to comply with the limits for a Class A digital device, pursuant to part 15 of the FCC Rules. These limits are designed to provide reasonable protection against harmful interference when the equipment is operated in a commercial environment. This equipment generates, uses, and can radiate radio frequency energy and, if not installed and used in accordance with the instruction manual, may cause harmful interference to radio communications. Operation of this equipment in a residential area is likely to cause harmful interference in which case the user will be required to correct the interference at his own expense.*

## **FCC Interference Statement for Class B EVM devices**

*NOTE: This equipment has been tested and found to comply with the limits for a Class B digital device, pursuant to part 15 of the FCC Rules. These limits are designed to provide reasonable protection against harmful interference in a residential installation. This equipment generates, uses and can radiate radio frequency energy and, if not installed and used in accordance with the instructions, may cause harmful interference to radio communications. However, there is no guarantee that interference will not occur in a particular installation. If this equipment does cause harmful interference to radio or television reception, which can be determined by turning the equipment off and on, the user is encouraged to try to correct the interference by one or more of the following measures:*

- Reorient or relocate the receiving antenna.
- Increase the separation between the equipment and receiver.
- Connect the equipment into an outlet on a circuit different from that to which the receiver is connected.
- Consult the dealer or an experienced radio/TV technician for help.

### 3.2 Canada

3.2.1 For EVMs issued with an Industry Canada Certificate of Conformance to RSS-210 or RSS-247

#### **Concerning EVMs Including Radio Transmitters:**

This device complies with Industry Canada license-exempt RSSs. Operation is subject to the following two conditions:

(1) this device may not cause interference, and (2) this device must accept any interference, including interference that may cause undesired operation of the device.

#### **Concernant les EVMs avec appareils radio:**

Le présent appareil est conforme aux CNR d'Industrie Canada applicables aux appareils radio exempts de licence. L'exploitation est autorisée aux deux conditions suivantes: (1) l'appareil ne doit pas produire de brouillage, et (2) l'utilisateur de l'appareil doit accepter tout brouillage radioélectrique subi, même si le brouillage est susceptible d'en compromettre le fonctionnement.

#### **Concerning EVMs Including Detachable Antennas:**

Under Industry Canada regulations, this radio transmitter may only operate using an antenna of a type and maximum (or lesser) gain approved for the transmitter by Industry Canada. To reduce potential radio interference to other users, the antenna type and its gain should be so chosen that the equivalent isotropically radiated power (e.i.r.p.) is not more than that necessary for successful communication. This radio transmitter has been approved by Industry Canada to operate with the antenna types listed in the user guide with the maximum permissible gain and required antenna impedance for each antenna type indicated. Antenna types not included in this list, having a gain greater than the maximum gain indicated for that type, are strictly prohibited for use with this device.

#### **Concernant les EVMs avec antennes détachables**

Conformément à la réglementation d'Industrie Canada, le présent émetteur radio peut fonctionner avec une antenne d'un type et d'un gain maximal (ou inférieur) approuvé pour l'émetteur par Industrie Canada. Dans le but de réduire les risques de brouillage radioélectrique à l'intention des autres utilisateurs, il faut choisir le type d'antenne et son gain de sorte que la puissance isotrope rayonnée équivalente (p.i.r.e.) ne dépasse pas l'intensité nécessaire à l'établissement d'une communication satisfaisante. Le présent émetteur radio a été approuvé par Industrie Canada pour fonctionner avec les types d'antenne énumérés dans le manuel d'usage et ayant un gain admissible maximal et l'impédance requise pour chaque type d'antenne. Les types d'antenne non inclus dans cette liste, ou dont le gain est supérieur au gain maximal indiqué, sont strictement interdits pour l'exploitation de l'émetteur.

### 3.3 Japan

3.3.1 *Notice for EVMs delivered in Japan:* Please see [http://www.tij.co.jp/lstds/ti\\_ja/general/eStore/notice\\_01.page](http://www.tij.co.jp/lstds/ti_ja/general/eStore/notice_01.page) 日本国内に輸入される評価用キット、ボードについては、次のところをご覧ください。  
[http://www.tij.co.jp/lstds/ti\\_ja/general/eStore/notice\\_01.page](http://www.tij.co.jp/lstds/ti_ja/general/eStore/notice_01.page)

3.3.2 *Notice for Users of EVMs Considered "Radio Frequency Products" in Japan:* EVMs entering Japan may not be certified by TI as conforming to Technical Regulations of Radio Law of Japan.

If User uses EVMs in Japan, not certified to Technical Regulations of Radio Law of Japan, User is required to follow the instructions set forth by Radio Law of Japan, which includes, but is not limited to, the instructions below with respect to EVMs (which for the avoidance of doubt are stated strictly for convenience and should be verified by User):

1. Use EVMs in a shielded room or any other test facility as defined in the notification #173 issued by Ministry of Internal Affairs and Communications on March 28, 2006, based on Sub-section 1.1 of Article 6 of the Ministry's Rule for Enforcement of Radio Law of Japan,
2. Use EVMs only after User obtains the license of Test Radio Station as provided in Radio Law of Japan with respect to EVMs, or
3. Use of EVMs only after User obtains the Technical Regulations Conformity Certification as provided in Radio Law of Japan with respect to EVMs. Also, do not transfer EVMs, unless User gives the same notice above to the transferee. Please note that if User does not follow the instructions above, User will be subject to penalties of Radio Law of Japan.

【無線電波を送信する製品の開発キットをお使いになる際の注意事項】 開発キットの中には技術基準適合証明を受けていないものがあります。技術適合証明を受けていないものご使用に際しては、電波法遵守のため、以下のいずれかの措置を取っていただく必要がありますのでご注意ください。

1. 電波法施行規則第6条第1項第1号に基づく平成18年3月28日総務省告示第173号で定められた電波暗室等の試験設備でご使用いただく。
2. 実験局の免許を取得後ご使用いただく。
3. 技術基準適合証明を取得後ご使用いただく。

なお、本製品は、上記の「ご使用にあたっての注意」を譲渡先、移転先に通知しない限り、譲渡、移転できないものとします。

上記を遵守頂けない場合は、電波法の罰則が適用される可能性があることをご留意ください。日本テキサス・インスツルメンツ株式会社  
東京都新宿区西新宿 6 丁目 2 4 番 1 号  
西新宿三井ビル

3.3.3 *Notice for EVMs for Power Line Communication:* Please see [http://www.tij.co.jp/lstds/ti\\_ja/general/eStore/notice\\_02.page](http://www.tij.co.jp/lstds/ti_ja/general/eStore/notice_02.page)  
電力線搬送波通信についての開発キットをお使いになる際の注意事項については、次のところをご覧ください。 [http://www.tij.co.jp/lstds/ti\\_ja/general/eStore/notice\\_02.page](http://www.tij.co.jp/lstds/ti_ja/general/eStore/notice_02.page)

#### 3.4 *European Union*

##### 3.4.1 *For EVMs subject to EU Directive 2014/30/EU (Electromagnetic Compatibility Directive):*

This is a class A product intended for use in environments other than domestic environments that are connected to a low-voltage power-supply network that supplies buildings used for domestic purposes. In a domestic environment this product may cause radio interference in which case the user may be required to take adequate measures.

#### 4 *EVM Use Restrictions and Warnings:*

4.1 EVMS ARE NOT FOR USE IN FUNCTIONAL SAFETY AND/OR SAFETY CRITICAL EVALUATIONS, INCLUDING BUT NOT LIMITED TO EVALUATIONS OF LIFE SUPPORT APPLICATIONS.

4.2 User must read and apply the user guide and other available documentation provided by TI regarding the EVM prior to handling or using the EVM, including without limitation any warning or restriction notices. The notices contain important safety information related to, for example, temperatures and voltages.

##### 4.3 *Safety-Related Warnings and Restrictions:*

4.3.1 User shall operate the EVM within TI's recommended specifications and environmental considerations stated in the user guide, other available documentation provided by TI, and any other applicable requirements and employ reasonable and customary safeguards. Exceeding the specified performance ratings and specifications (including but not limited to input and output voltage, current, power, and environmental ranges) for the EVM may cause personal injury or death, or property damage. If there are questions concerning performance ratings and specifications, User should contact a TI field representative prior to connecting interface electronics including input power and intended loads. Any loads applied outside of the specified output range may also result in unintended and/or inaccurate operation and/or possible permanent damage to the EVM and/or interface electronics. Please consult the EVM user guide prior to connecting any load to the EVM output. If there is uncertainty as to the load specification, please contact a TI field representative. During normal operation, even with the inputs and outputs kept within the specified allowable ranges, some circuit components may have elevated case temperatures. These components include but are not limited to linear regulators, switching transistors, pass transistors, current sense resistors, and heat sinks, which can be identified using the information in the associated documentation. When working with the EVM, please be aware that the EVM may become very warm.

4.3.2 EVMs are intended solely for use by technically qualified, professional electronics experts who are familiar with the dangers and application risks associated with handling electrical mechanical components, systems, and subsystems. User assumes all responsibility and liability for proper and safe handling and use of the EVM by User or its employees, affiliates, contractors or designees. User assumes all responsibility and liability to ensure that any interfaces (electronic and/or mechanical) between the EVM and any human body are designed with suitable isolation and means to safely limit accessible leakage currents to minimize the risk of electrical shock hazard. User assumes all responsibility and liability for any improper or unsafe handling or use of the EVM by User or its employees, affiliates, contractors or designees.

4.4 User assumes all responsibility and liability to determine whether the EVM is subject to any applicable international, federal, state, or local laws and regulations related to User's handling and use of the EVM and, if applicable, User assumes all responsibility and liability for compliance in all respects with such laws and regulations. User assumes all responsibility and liability for proper disposal and recycling of the EVM consistent with all applicable international, federal, state, and local requirements.

5. *Accuracy of Information:* To the extent TI provides information on the availability and function of EVMs, TI attempts to be as accurate as possible. However, TI does not warrant the accuracy of EVM descriptions, EVM availability or other information on its websites as accurate, complete, reliable, current, or error-free.

6. *Disclaimers:*

6.1 EXCEPT AS SET FORTH ABOVE, EVMS AND ANY MATERIALS PROVIDED WITH THE EVM (INCLUDING, BUT NOT LIMITED TO, REFERENCE DESIGNS AND THE DESIGN OF THE EVM ITSELF) ARE PROVIDED "AS IS" AND "WITH ALL FAULTS." TI DISCLAIMS ALL OTHER WARRANTIES, EXPRESS OR IMPLIED, REGARDING SUCH ITEMS, INCLUDING BUT NOT LIMITED TO ANY EPIDEMIC FAILURE WARRANTY OR IMPLIED WARRANTIES OF MERCHANTABILITY OR FITNESS FOR A PARTICULAR PURPOSE OR NON-INFRINGEMENT OF ANY THIRD PARTY PATENTS, COPYRIGHTS, TRADE SECRETS OR OTHER INTELLECTUAL PROPERTY RIGHTS.

6.2 EXCEPT FOR THE LIMITED RIGHT TO USE THE EVM SET FORTH HEREIN, NOTHING IN THESE TERMS SHALL BE CONSTRUED AS GRANTING OR CONFERRING ANY RIGHTS BY LICENSE, PATENT, OR ANY OTHER INDUSTRIAL OR INTELLECTUAL PROPERTY RIGHT OF TI, ITS SUPPLIERS/LICENSORS OR ANY OTHER THIRD PARTY, TO USE THE EVM IN ANY FINISHED END-USER OR READY-TO-USE FINAL PRODUCT, OR FOR ANY INVENTION, DISCOVERY OR IMPROVEMENT, REGARDLESS OF WHEN MADE, CONCEIVED OR ACQUIRED.

7. *USER'S INDEMNITY OBLIGATIONS AND REPRESENTATIONS.* USER WILL DEFEND, INDEMNIFY AND HOLD TI, ITS LICENSORS AND THEIR REPRESENTATIVES HARMLESS FROM AND AGAINST ANY AND ALL CLAIMS, DAMAGES, LOSSES, EXPENSES, COSTS AND LIABILITIES (COLLECTIVELY, "CLAIMS") ARISING OUT OF OR IN CONNECTION WITH ANY HANDLING OR USE OF THE EVM THAT IS NOT IN ACCORDANCE WITH THESE TERMS. THIS OBLIGATION SHALL APPLY WHETHER CLAIMS ARISE UNDER STATUTE, REGULATION, OR THE LAW OF TORT, CONTRACT OR ANY OTHER LEGAL THEORY, AND EVEN IF THE EVM FAILS TO PERFORM AS DESCRIBED OR EXPECTED.

8. *Limitations on Damages and Liability:*

8.1 *General Limitations.* IN NO EVENT SHALL TI BE LIABLE FOR ANY SPECIAL, COLLATERAL, INDIRECT, PUNITIVE, INCIDENTAL, CONSEQUENTIAL, OR EXEMPLARY DAMAGES IN CONNECTION WITH OR ARISING OUT OF THESE TERMS OR THE USE OF THE EVMS, REGARDLESS OF WHETHER TI HAS BEEN ADVISED OF THE POSSIBILITY OF SUCH DAMAGES. EXCLUDED DAMAGES INCLUDE, BUT ARE NOT LIMITED TO, COST OF REMOVAL OR REINSTALLATION, ANCILLARY COSTS TO THE PROCUREMENT OF SUBSTITUTE GOODS OR SERVICES, RETESTING, OUTSIDE COMPUTER TIME, LABOR COSTS, LOSS OF GOODWILL, LOSS OF PROFITS, LOSS OF SAVINGS, LOSS OF USE, LOSS OF DATA, OR BUSINESS INTERRUPTION. NO CLAIM, SUIT OR ACTION SHALL BE BROUGHT AGAINST TI MORE THAN TWELVE (12) MONTHS AFTER THE EVENT THAT GAVE RISE TO THE CAUSE OF ACTION HAS OCCURRED.

8.2 *Specific Limitations.* IN NO EVENT SHALL TI'S AGGREGATE LIABILITY FROM ANY USE OF AN EVM PROVIDED HEREUNDER, INCLUDING FROM ANY WARRANTY, INDEMNITY OR OTHER OBLIGATION ARISING OUT OF OR IN CONNECTION WITH THESE TERMS, EXCEED THE TOTAL AMOUNT PAID TO TI BY USER FOR THE PARTICULAR EVM(S) AT ISSUE DURING THE PRIOR TWELVE (12) MONTHS WITH RESPECT TO WHICH LOSSES OR DAMAGES ARE CLAIMED. THE EXISTENCE OF MORE THAN ONE CLAIM SHALL NOT ENLARGE OR EXTEND THIS LIMIT.

9. *Return Policy.* Except as otherwise provided, TI does not offer any refunds, returns, or exchanges. Furthermore, no return of EVM(s) will be accepted if the package has been opened and no return of the EVM(s) will be accepted if they are damaged or otherwise not in a resalable condition. If User feels it has been incorrectly charged for the EVM(s) it ordered or that delivery violates the applicable order, User should contact TI. All refunds will be made in full within thirty (30) working days from the return of the components(s), excluding any postage or packaging costs.

10. *Governing Law:* These terms and conditions shall be governed by and interpreted in accordance with the laws of the State of Texas, without reference to conflict-of-laws principles. User agrees that non-exclusive jurisdiction for any dispute arising out of or relating to these terms and conditions lies within courts located in the State of Texas and consents to venue in Dallas County, Texas. Notwithstanding the foregoing, any judgment may be enforced in any United States or foreign court, and TI may seek injunctive relief in any United States or foreign court.

## IMPORTANT NOTICE FOR TI DESIGN INFORMATION AND RESOURCES

Texas Instruments Incorporated ("TI") technical, application or other design advice, services or information, including, but not limited to, reference designs and materials relating to evaluation modules, (collectively, "TI Resources") are intended to assist designers who are developing applications that incorporate TI products; by downloading, accessing or using any particular TI Resource in any way, you (individually or, if you are acting on behalf of a company, your company) agree to use it solely for this purpose and subject to the terms of this Notice.

TI's provision of TI Resources does not expand or otherwise alter TI's applicable published warranties or warranty disclaimers for TI products, and no additional obligations or liabilities arise from TI providing such TI Resources. TI reserves the right to make corrections, enhancements, improvements and other changes to its TI Resources.

You understand and agree that you remain responsible for using your independent analysis, evaluation and judgment in designing your applications and that you have full and exclusive responsibility to assure the safety of your applications and compliance of your applications (and of all TI products used in or for your applications) with all applicable regulations, laws and other applicable requirements. You represent that, with respect to your applications, you have all the necessary expertise to create and implement safeguards that (1) anticipate dangerous consequences of failures, (2) monitor failures and their consequences, and (3) lessen the likelihood of failures that might cause harm and take appropriate actions. You agree that prior to using or distributing any applications that include TI products, you will thoroughly test such applications and the functionality of such TI products as used in such applications. TI has not conducted any testing other than that specifically described in the published documentation for a particular TI Resource.

You are authorized to use, copy and modify any individual TI Resource only in connection with the development of applications that include the TI product(s) identified in such TI Resource. NO OTHER LICENSE, EXPRESS OR IMPLIED, BY ESTOPPEL OR OTHERWISE TO ANY OTHER TI INTELLECTUAL PROPERTY RIGHT, AND NO LICENSE TO ANY TECHNOLOGY OR INTELLECTUAL PROPERTY RIGHT OF TI OR ANY THIRD PARTY IS GRANTED HEREIN, including but not limited to any patent right, copyright, mask work right, or other intellectual property right relating to any combination, machine, or process in which TI products or services are used. Information regarding or referencing third-party products or services does not constitute a license to use such products or services, or a warranty or endorsement thereof. Use of TI Resources may require a license from a third party under the patents or other intellectual property of the third party, or a license from TI under the patents or other intellectual property of TI.

TI RESOURCES ARE PROVIDED "AS IS" AND WITH ALL FAULTS. TI DISCLAIMS ALL OTHER WARRANTIES OR REPRESENTATIONS, EXPRESS OR IMPLIED, REGARDING TI RESOURCES OR USE THEREOF, INCLUDING BUT NOT LIMITED TO ACCURACY OR COMPLETENESS, TITLE, ANY EPIDEMIC FAILURE WARRANTY AND ANY IMPLIED WARRANTIES OF MERCHANTABILITY, FITNESS FOR A PARTICULAR PURPOSE, AND NON-INFRINGEMENT OF ANY THIRD PARTY INTELLECTUAL PROPERTY RIGHTS.

TI SHALL NOT BE LIABLE FOR AND SHALL NOT DEFEND OR INDEMNIFY YOU AGAINST ANY CLAIM, INCLUDING BUT NOT LIMITED TO ANY INFRINGEMENT CLAIM THAT RELATES TO OR IS BASED ON ANY COMBINATION OF PRODUCTS EVEN IF DESCRIBED IN TI RESOURCES OR OTHERWISE. IN NO EVENT SHALL TI BE LIABLE FOR ANY ACTUAL, DIRECT, SPECIAL, COLLATERAL, INDIRECT, PUNITIVE, INCIDENTAL, CONSEQUENTIAL OR EXEMPLARY DAMAGES IN CONNECTION WITH OR ARISING OUT OF TI RESOURCES OR USE THEREOF, AND REGARDLESS OF WHETHER TI HAS BEEN ADVISED OF THE POSSIBILITY OF SUCH DAMAGES.

You agree to fully indemnify TI and its representatives against any damages, costs, losses, and/or liabilities arising out of your non-compliance with the terms and provisions of this Notice.

This Notice applies to TI Resources. Additional terms apply to the use and purchase of certain types of materials, TI products and services. These include; without limitation, TI's standard terms for semiconductor products (<http://www.ti.com/sc/docs/stdterms.htm>), [evaluation modules](#), and [samples](http://www.ti.com/sc/docs/sampterm.htm) (<http://www.ti.com/sc/docs/sampterm.htm>).

Mailing Address: Texas Instruments, Post Office Box 655303, Dallas, Texas 75265  
Copyright © 2017, Texas Instruments Incorporated