

Inductor Selection in Boost Converters for LCD Backlight Applications

Travis Eichhorn

ABSTRACT

White LED drivers for LCD back-light applications are often designed for battery-powered devices. This makes circuit size and efficiency crucial. Because of this, selecting the optimal inductor is one of the most important aspects of the design. This application note discusses the important parameters of the inductor and how to select the right inductor for the application.

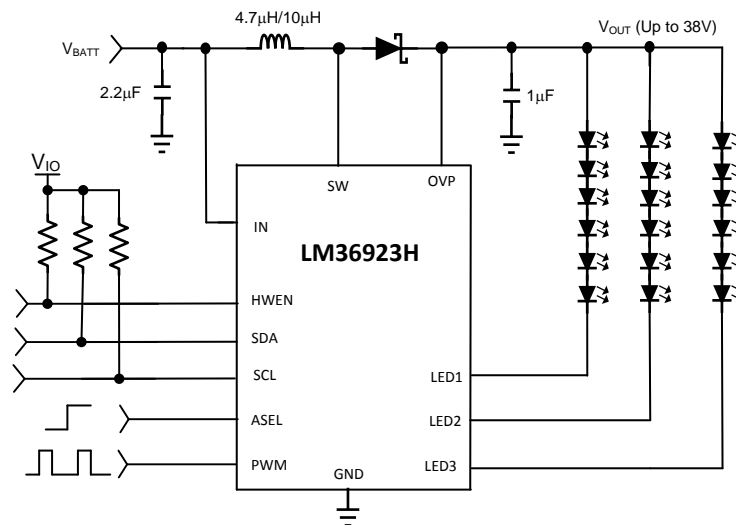

Figure 1. Typical White LED Backlight Driver Boost Converter

1 Inductor Requirements

TI's LCD backlight boost converters specify an inductor within a certain nominal value, or within a range of inductor values. This intended range accounts for inductor tolerances and some variation in inductance with current. Keeping the inductor within this intended range of operation ensures the following:

- The boost feedback loop remains stable (inductor is not too large); and
- The boost slope compensation is adequate (inductor is not too small).

[Table 1](#) lists available LCD back-light drivers with integrated boost converters and their intended inductance range.

Table 1. Some of TI's LCD Backlight Drivers With Integrated Boost Controllers

DEVICE	NO. OF LED STRINGS	MAXIMUM V _{OUT}	V _{IN} RANGE	SWITCHING FREQUENCY OPTIONS	PEAK SWITCH CURRENT (ICL MINIMUM)	MAXIMUM CURRENT PER STRING	NOMINAL INDUCTOR RANGE	SPECIAL FEATURES
LM36922/23H	2/3	38 V	2.5 V to 5.5 V	500kHz/1MHz	1.35 A	25 mA	4.7 μH to 10 μH	Backlight adjust input
LM36274/3/2	4/3/2	28 V	2.5 V to 5.5 V	500kHz/1MHz	1.5 A	30 mA	4.7 μH to 10 μH	Integrated LCD bias
LM3697	3	38.75 V	2.5 V to 5.5 V	500kHz/1MHz	880 mA	29.8 mA	4.7 μH to 22 μH	Dual control banks
TPS61165	1	37 V	3 V to 18 V	1.2 MHz	960 mA	External RSET	10 μH to 22 μH	High V _{IN} + 1-Wire/PWM
TPS61161	1	37 V	3 V to 18 V	600 kHz	560 mA	External RSET	10 μH to 22 μH	High V _{IN} + 1-Wire/PWM
TPS61160	1	25 V	3 V to 18 V	600 kHz	560 mA	External RSET	10 μH to 22 μH	High V _{IN} + 1-Wire/PWM
LM3530	1	40 V	2.5 V to 5.5 V	500 kHz	739 mA	29.5 mA	10 μH to 22 μH	Ambient light sensor control
LM3532	3	40 V	2.5 V to 5.5 V	500 kHz	880 mA	29.8 mA	10 μH to 22 μH	Independent string control
LM3633	3	39 V	2.5 V to 5.5 V	500 kHz/1 MHz	880 mA	29.8 mA	4.7 μH to 22 μH	6 Indicator drivers with pattern control
LM3533	2	39 V	2.5 V to 5.5 V	500 kHz/1 MHz	880 mA	29.8 mA	4.7 μH to 22 μH	5 Indicator drivers with pattern control
LM3528	2	19.25 V	2.5 V to 5.5 V	1.25 MHz	645 mA	30 mA	10 μH to 22 μH	Independent string control
LM3509	2	19.25 V	2.5 V to 5.5 V	1.25 MHz	645 mA	30 mA	10 μH to 22 μH	Independent string control
LM3508	1	17.5 V	2.5 V to 5.5 V	850 kHz	370 mA	30 mA	10 μH to 22 μH	Synchronous FET
LM3632A	2	28 V	2.5 V to 5.5 V	500 kHz/1 MHz	900 mA	25 mA	10 μH to 22 μH	Integrated LCD bias + flash LED
LM3639	2	38.4 V	2.5 V to 5.5 V	500 kHz/1 MHz	900 mA	29.5 mA	10 μH to 22 μH	Integrated flash LED
TPS61158	1	27.5 V	2.5 V to 5.5 V	750 kHz	500 mA	External RSET	10 μH to 22 μH	Integrated diode + 1-Wire
TPS61169	1	36 V	2.5 V to 5.5 V	1.2 MHz	1.2 A	External RSET	4.7 μH to 22 μH	
TPS61150	2	27 V	2.5 V to 6 V	1.2 MHz	750 mA	35 mA	10 μH	Dual RSET, dual pwm control
TPS61151	2	21 V	2.5 V to 6 V	1.2 MHz	750 mA	35 mA	10 μH	Dual RSET, dual pwm control
TPS61162A	2	25 V	2.5 V to 5.5 V	1.2 MHz	1 A	30 mA	4.7 μH to 10 μH	1-Wire + PWM
TPS61163A	2	36 V	2.5 V to 5.5 V	1.2 MHz	1 A	30 mA	4.7 μH to 10 μH	1-Wire + PWM

1.1 Inductor Value Example

As an example, assume a 4.7-μH (nominal value) inductor is chosen to use with the LM36923H. The LM36923H has an intended inductor range of 4.7 μH to 10 μH and assumes the inductor can deviate up to ±30% from nominal. With a 4.7-μH nominal inductor this gives a range of 3.29 μH to 6.11 μH. Note: this is accounting for the tolerance of the inductor and not implying that a 3.3-μH inductor is OK to use. Many of TI's backlight drivers only list a nominal value inductor. However, using the recommended inductor in the datasheet's Application Circuit Component List can be used as a target for inductor tolerance and saturation current derating.

2 Inductor Current Rating and Output Power Requirement

Once the nominal inductance has been determined, the inductor must then be chosen to handle the required current. In a boost, the inductor current rating is determined by either the peak current or the RMS current requirement of the application.

The peak current of the application (IL_PEAK) is different than the peak current limit of the boost (ICL). ICL must always be greater than IL_PEAK. ICL is the max rating that the boost NMOS can handle, whereas IL_PEAK is the peak operating current of the application which depends on:

- Minimum input voltage (VIN_MIN)
- Maximum output voltage (VOUT_MAX)
- Maximum output current (IOUT_MAX)
- Minimum boost switching frequency (fSW_MIN)
- Minimum inductance (LMIN)
- Boost efficiency

The peak operating current is given as the DC inductor current + 1/2 the inductor current ripple:

$$IL_PEAK = \left(\frac{VOUT_MAX \times ILED_TOTAL}{VIN \times efficiency} + \frac{VIN_MIN}{2 \times f_{SW} \times L} \times \frac{(VOUT_MAX - VIN_MIN \times efficiency)}{VOUT_MAX} \right)$$

(1)

The inductors RMS current (IL_RMS) is the effective current which leads to most of the inductor's self heating. This is given as:

$$I_{RMS_L} = \sqrt{\left(\frac{V_{OUT_MAX} \times I_{LED_TOTAL}}{V_{IN_MIN} \times efficiency}\right)^2 + \frac{\Delta I_L^2}{12}} \quad (2)$$

ΔI_L is the inductor peak to peak current ripple given as:

$$\Delta I_L = \frac{V_{IN} \times D}{f_{SW} \times L} \quad (3)$$

D is the boost duty cycle in continuous conduction mode, given as:

$$D = \frac{V_{OUT_MAX} - V_{IN_MIN} \times efficiency}{V_{OUT_MAX}} \quad (4)$$

Typically there are two current ratings associated with an inductor:

- The current rating that leads to a decrease in inductance from nominal (saturation rating). Using this as the maximum inductor current requires designing for IL_PEAK.
- The current rating that leads to a specific rise in inductor temperature above ambient (temperature rating based on $R_{\theta JA}$ and inductor DC resistance). Using this requires designing for IL_RMS.

Use one of these currents when choosing the inductor, depending on the type of inductor selected.

2.1 Sharp Saturation vs Soft Saturation

Inductor current capabilities are dependent on the type of inductor selected (saturation type). Inductors can have (normally) 2 types of saturation responses. One is a sharp saturation response where the inductance shows a sharp drop-off of at some current. The other type shows a soft saturation response which has a gradual (almost linear) change in inductance with current. These two types of saturation characteristics are shown in [Figure 2](#).

Inductor no. 1 (sharp saturation type) has a listed saturation current of 1.08 A. The definition of saturation for this type inductor is where L has dropped by 30% from its nominal value. Sharp saturation inductors often have a secondary (higher current rating), which is the current at which the inductor temperature has increased by a certain amount above ambient. The lower of the two currents is normally the one which determines the inductor current rating. The other main feature of the sharp saturation inductor is its fairly constant inductance vs current for $I_L < I_{SAT}$.

Inductor no. 2 shows a soft saturation characteristic. This type of device shows a more constant reduction in inductance vs DC current starting at 0. The current rating for the soft saturation device is normally a single current, which is determined by the device temperature rise above ambient. In the case of inductor no. 2, this device has a 1-A current rating, which is more similar to the temperature rise current rating of inductor no. 1.

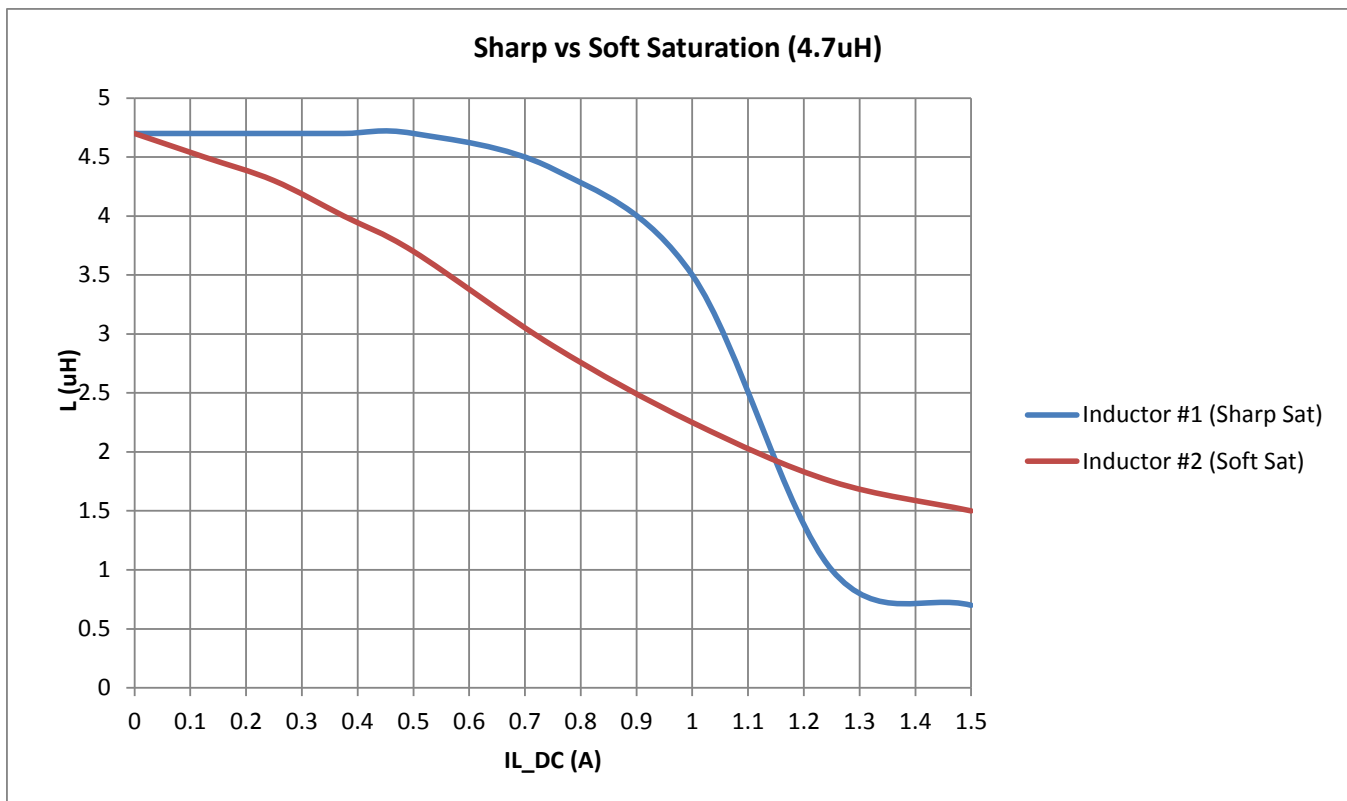

Figure 2. Inductor Saturation Types

2.1.1 Sharp Saturation Inductor

The sharp saturation type inductor is the optimum to use with most boost LED drivers. The relatively constant inductance vs I_L makes the inductance easier to predict and ensures it stays in the range of usable inductance across the intended operating range. Use the current rating, which is given as the point where L has dropped 20% from nominal, as the inductor's effective ISAT. This ISAT value must be $\geq I_{L_PEAK}$ (see Equation 1). Because ISAT is given as a DC current and I_{L_PEAK} is targeted at less than this, gives some added margin from ISAT and the boost's operating DC current. For example, using inductor no. 1 from Figure 2, we have an ISAT of 950 mA (assuming a 20% reduction from L nominal). With tolerances of -20% , the operating inductance of L could be as low as $0.8 \times 0.8 \times 4.7 \mu\text{H} = 3 \mu\text{H}$. However, using the I_{L_PEAK} as the threshold for I_{L_SAT} means that I_{L_DC} is actually operating lower at $(I_{L_PEAK} - \Delta I_L/2)$. Using real numbers of ($V_{IN} = 2.8 \text{ V}$, $V_{OUT} = 25 \text{ V}$, $I_{OUT} = 69 \text{ mA}$ (23 mA/string), efficiency = 0.83, $L = 4.7 \mu\text{H} - 20\% = 3.76 \mu\text{H}$) results in the following:

- $D = 90.7\%$
- $I_{L_DC} = 645 \text{ mA}$
- $I_{L_PEAK} = 983 \text{ mA}$
- $\Delta I_L/2 = (I_{L_PEAK} - I_{L_DC}) = 338 \text{ mA}$

We can see that the given configuration requires at least 983 mA of peak current. Because we target I_{L_PEAK} to be $\leq I_{L_SAT}$, this leaves 338 mA of margin from the operating I_{L_DC} and our inductor's targeted I_{L_SAT} . Looking at the curve of Figure 2 shows that at 645 mA, L has only decreased down to 4.5 μH (5% to 6% below nominal). Then, with tolerances of -20% , we get a target minimum inductance of $0.8 \times 0.95 \times 4.7 \mu\text{H} = 3.6 \mu\text{H}$ — less than our minimum of 3.3 μH .

Given the peak current requirements of the application and the potential inductor deratings, inductor no. 1 makes a good choice for the typical application.

2.1.2 Soft Saturation Inductor

If a soft saturation type inductor is selected, the maximum current of the inductor is not as straightforward as the sharp saturation inductor. The maximum listed current for the device is given as the DC current, which results in a certain temperature rise above ambient. Because the current rating of the inductor is based on temperature rise, IL_PEAK is not used as the threshold, but instead IL_RMS is used since it accounts for the self heating from the DC and the inductor current ripple, (primarily due to the inductors DC resistance, see [Equation 2](#)).

However, for soft saturation inductors the maximum listed current will most likely cause L to drop below the minimum required L for the application. In [Figure 2](#), inductor no. 2 would have a much lower rated current than its listed maximum value of 1000 mA due to the inductance derating vs current. Because of this, the current rating for soft saturation inductors can be determined by the current value, which yields the minimum inductance required for the application. For example, assume the minimum inductance is 3.3 μH (accounting for derating and 20% tolerances). This means that the nominal derated value must be greater than $3.3 \mu\text{H} / 0.8 = 4.125 \mu\text{H}$. On the derating curve for inductor no. 2, the current that corresponds to 4.125 μH is approximately 350 mA. (This is a good reason why sharp saturation inductors are a better choice.) The configuration example give before ($V_{IN} = 2.8 \text{ V}$, $V_{OUT} = 25 \text{ V}$, $I_{OUT} = 69 \text{ mA}$ (23mA/string), efficiency = 0.83, $L = 4.7 \mu\text{H} - 20\% = 3.76 \mu\text{H}$), would not work for inductor no. 2. Either the inductor size would need to be increases, or the operating point would need to be adjusted.

If a soft saturation inductor is selected, the current rating can be determined at different operating point by rearranging [Equation 2](#) and solving for the different operating points (I_{OUT} , V_{OUT} , V_{IN}):

$$I_{OUT_MAX} = \frac{V_{IN_MIN} \times efficiency}{V_{OUT_MAX}} \times \sqrt{\left(IL_MAX^2 + \frac{\Delta IL^2}{12} \right)} \quad (5)$$

$$V_{OUT_MAX} = \frac{V_{IN_MIN} \times efficiency}{I_{OUT_MAX}} \times \sqrt{\left(IL_MAX^2 + \frac{\Delta IL^2}{12} \right)} \quad (6)$$

$$V_{IN_MIN} = \frac{V_{OUT_MAX} \times I_{OUT_MAX}}{efficiency \times \sqrt{\left(IL_MAX^2 + \frac{\Delta IL^2}{12} \right)}} \quad (7)$$

2.1.3 IL_RMS vs IL_DC Approximation in CCM Operation

In reality the RMS inductor current would only be needed if ΔIL was large in comparison to the DC current. [Figure 3](#) displays this effect. The curve is a plot of the ratio of IL_RMS^2 / IL_DC^2 plotted against the % of inductor ripple current out of the DC current. We can see that when the ripple current is 100% of the DC current (that is, if I_{DC} was 1 A, ΔIL would be 1 A peak-to-peak), that the ratio of RMS squared to DC squared is only around 1.08. In most cases the inductor current ripple is < 100% of I_{DC} indicating that a good approximation can be made that IL_RMS is equal to IL_DC). Therefore, for most use cases the $\Delta IL^2/12$ term can be ignored.

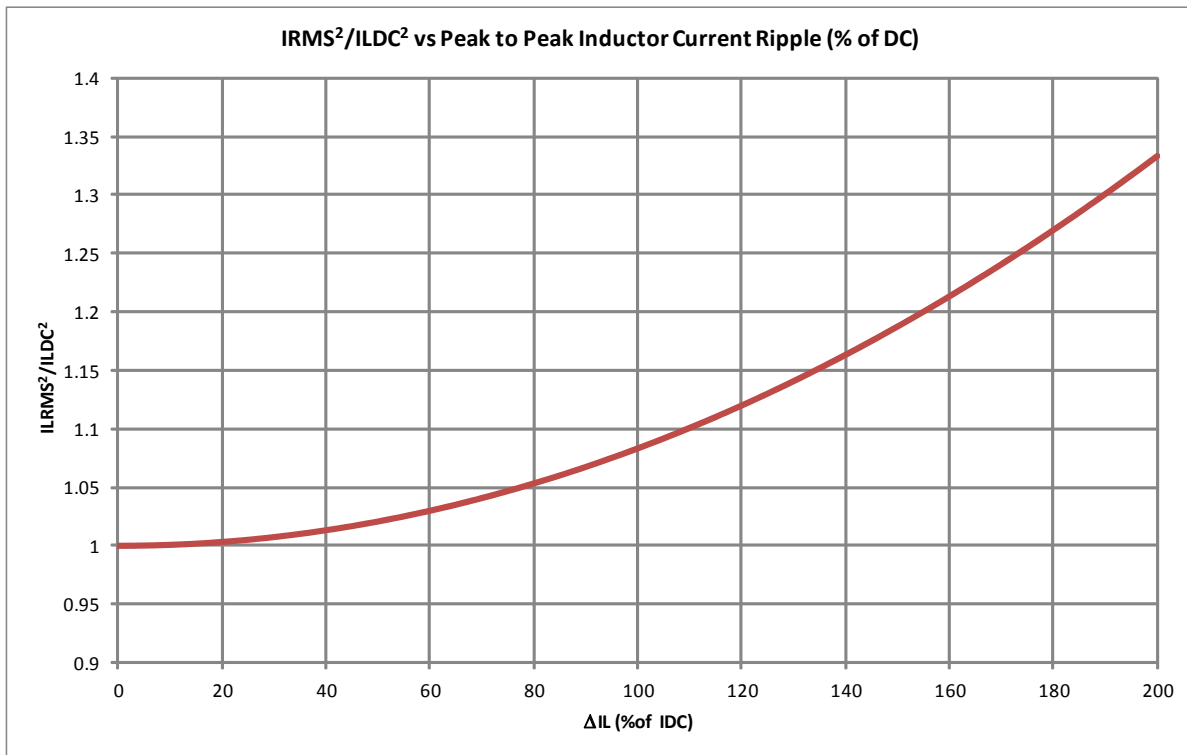

Figure 3. Effect of IL_RMS vs IL_DC

3 Inductor and Boost Efficiency

The inductor in the backlight boost circuit is the one of the largest components of efficiency loss and understanding where these losses occur can aid in selecting the optimal device.

The inductor's loss components can be broken down into two categories: DC losses and AC losses. DC losses are those due to the inductor's DC resistance. AC losses are those that vary with the boost switching frequency. These can be modeled with an AC resistance.

3.1 DC Resistance

The inductor's DC resistance is the resistance of the winding and is given for most all power inductors. The DC resistance dominates losses at high load currents. To determine the DC resistance's effect on efficiency, you need to determine the inductor RMS current. However, the RMS current is different depending on the magnitude of the load current. For high loads, the device most likely operates in continuous conduction mode (CCM) where the inductor current ramp never reaches 0 during the switching period (see [Figure 4](#)). For lighter loads the inductor operates in discontinuous conduction mode (DCM) where the inductor current ramps down to 0 at the end of the off time (tOFF), before the new switching period begins (see [Figure 5](#)).

To determine CCM vs DCM operation, first verify if the following is true:

$$I_{OUT} < \frac{V_{IN}^2}{V_{OUT}^2} \times \frac{\text{efficiency}}{2 \times f_{SW} \times L} \times (V_{OUT} - V_{IN} \times \text{efficiency}) \quad (8)$$

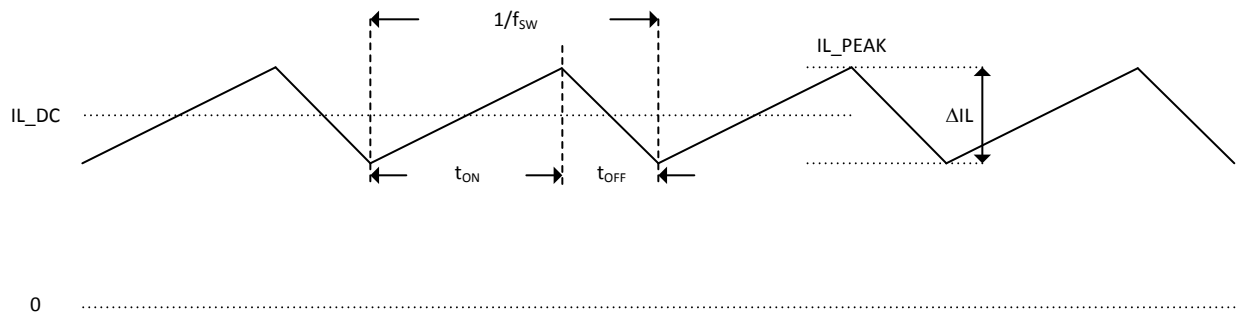
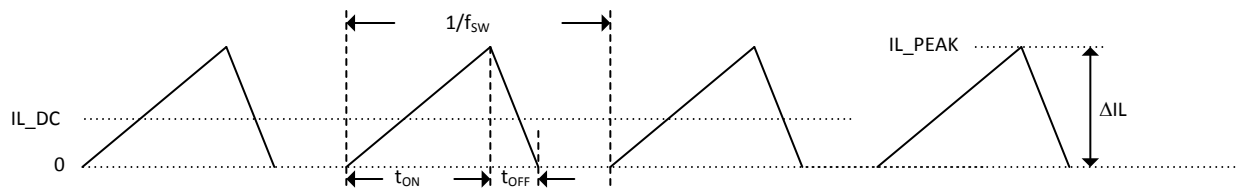
Figure 4. Continuous Conduction Mode

Figure 5. Discontinuous Conduction Mode

For CCM operation, IL_{RMS} is given in [Equation 2](#). The same advice holds true in the DC power loss calculation regarding RMS vs DC current in CCM operation (see [Section 2.1.3](#)). For circuits that operate in DCM, predominately the case at light loads, the calculation is a bit different (IL_{RMS} must be used in the case regardless). If the inequality is true in [Equation 8](#) then the calculation for the RMS current of the inductor in DCM is given [Equation 9](#):

$$IL_{RMS_DCM} = \sqrt{\frac{IL_{PEAK_DCM}^2}{3} \times (D_{DCM} + D_0)} \quad (9)$$

where

$$IL_{PEAK_DCM} = \sqrt{2 \times I_{OUT} \times \frac{(V_{OUT} - V_{IN} \times \text{efficiency})}{\text{efficiency} \times f_{SW} \times L}} \quad (10)$$

and

$$D_{DCM} = \frac{I_{PEAK_DCM} \times f_{SW} \times L}{V_{IN}} \quad (11)$$

and

$$D_0 = \frac{2 \times I_{OUT}}{I_{PEAK_DCM}} \quad (12)$$

3.2 AC Resistance

Inductor AC resistance models the losses which are a function of frequency. These include:

1. Inductor core loss (commonly called hysteresis loss) — these are the losses in the magnetic material that occur when the inductor stores and releases energy each switching cycle.
2. Induced currents in the core (commonly called Eddy currents) — these are induced in the core material as a reaction to the changing magnetic field.
3. Skin effect in the windings — these are due to the increase in RDC at higher frequency.

The hysteresis loss dominates the AC losses.

3.2.1 Inductor Q

Inductor Q plots are often shown in inductor data sheets and can give a good idea of the AC losses in the inductor. Q is the quality factor and is defined as the ratio of inductors reactance to the total resistive losses (X_L / R_s). Q is given vs frequency (see Figure 7). At low frequency, Q is basically X_L / R_{DC} , due to RAC being much less than RDC. As the frequency increases the component of RAC begins to dominate. At high frequency, Q has a minimum where the inductors distributed capacitance and inductive reactance are equal. This frequency is called the self-resonant frequency (SRF). Given the Q curve, a basic inductor model can be developed showing the inductors effective R(S), C, and L (see Figure 6).

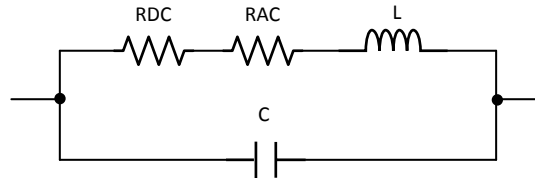

Figure 6. Inductor Basic Model

Inductors with higher Q have lower losses vs frequency. This typically results in higher light load efficiency in the boost.

3.2.2 Inductor RAC and effects on efficiency

Given a typical curve of Q vs f (see Figure 7 for three example inductors), we can estimate the inductors effective resistance vs frequency ($R(\text{effective}) = \omega L / Q$). RAC is then $R(\text{effective}) - R_{DC}$ (see Figure 8).

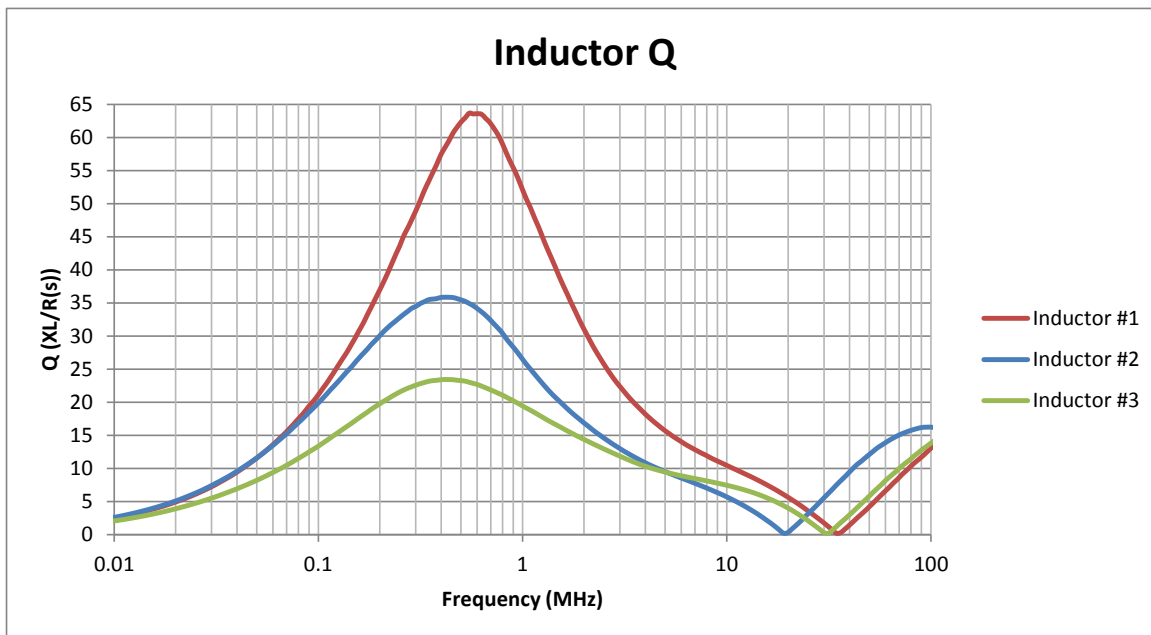

Figure 7. Q vs Frequency for the Three Example Inductors

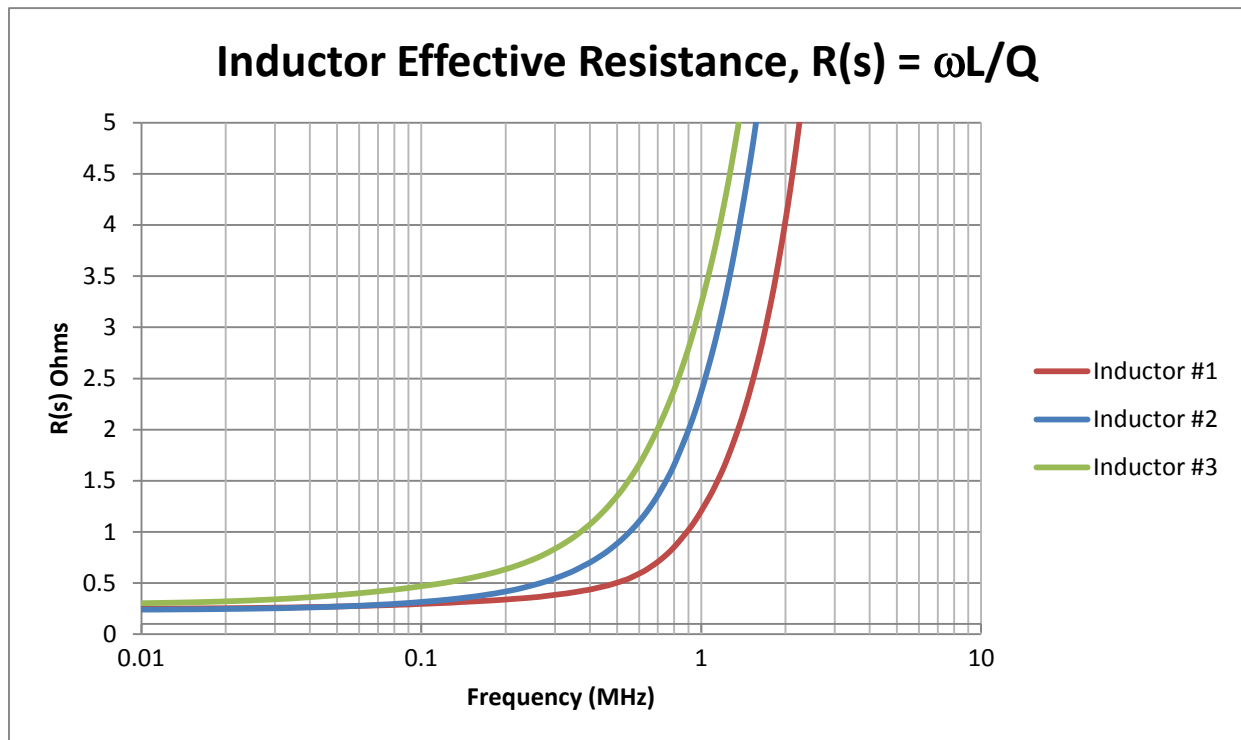

Figure 8. R(effective) vs Frequency for the Three Example Inductors

3.3 Efficiency

We can get a basic idea of how each of the R(effective) of the 3 inductors will have on the boost efficiency. Table 2 shows the breakdown of the losses due to the three example inductors given the following operating conditions ($V_{IN} = 3.6\text{ V}$, $2 \times 6\text{ LEDs}$ (V_{OUT} ranges from 16.3 V to 19.4 V), $f_{SW} = 1\text{ MHz}$). Figure 9 shows the measured efficiency of each circuit. We can see with inductor no. 3 the effect that lower Q has on light loads. However, this would not have been obvious by just looking at the DC resistance because RDC between the devices is similar. The Q plot correctly predicts that inductor no. 1 would have the best light load efficiency (Q being highest). The calculated effect of RDC and RAC gives a good indication of the performance of the inductor. This is very accurate with the RDC calculation; however, the RAC calculation misses the higher frequency harmonics in the triangle wave, as well as the losses associated with the peak-to-peak magnetic field swing in the inductor core (B(t)). This B(t) is proportional to the peak-to-peak inductor current and requires information about the inductor that is not given in the Q curve. Nonetheless, using Q as a method to compare two inductors gives a good insight as to the relative performance between inductors.

Table 2. Effects on Efficiency with Different Inductors

INDUCTOR	RDC	Q (@ 1 MHz)	Reffective @ 1 MHz	RAC (Reffective – RDC)	RDC (mW) (% of TOTAL)		P_RDC (mW) (% of TOTAL)		PL_TOTAL (mW) (% of TOTAL)	
					5 mA/string	20 mA/string	5 mA/string	20 mA/string	5 mA/string	20 mA/string
1	0.25 8 Ω	52.2	1.2 Ω	0.942 Ω	1.74 mW (0.87%)	17.9 mW (1.7%)	3.42 mW (1.7%)	7.2 mW (0.8%)	5.16 mW (2.57%)	25 mW (2.8%)
2	0.26 3 Ω	26.5	2.36 Ω	2.097 Ω	1.82 mW (0.89%)	18.3 mW (3.8%)	7.8 mW (3.8%)	16 mW (1.8%)	9.57 mW (4.7%)	34.2 mW (3.8%)
3	0.3 6 Ω	19.4	3.22 Ω	2.914 Ω	2.32 mW (1.07%)	22.5 mW (5.4%)	11.6 mW (5.4%)	22.4 mW (2.4%)	13.9 mW (6.4%)	44.9 mW (4.9%)

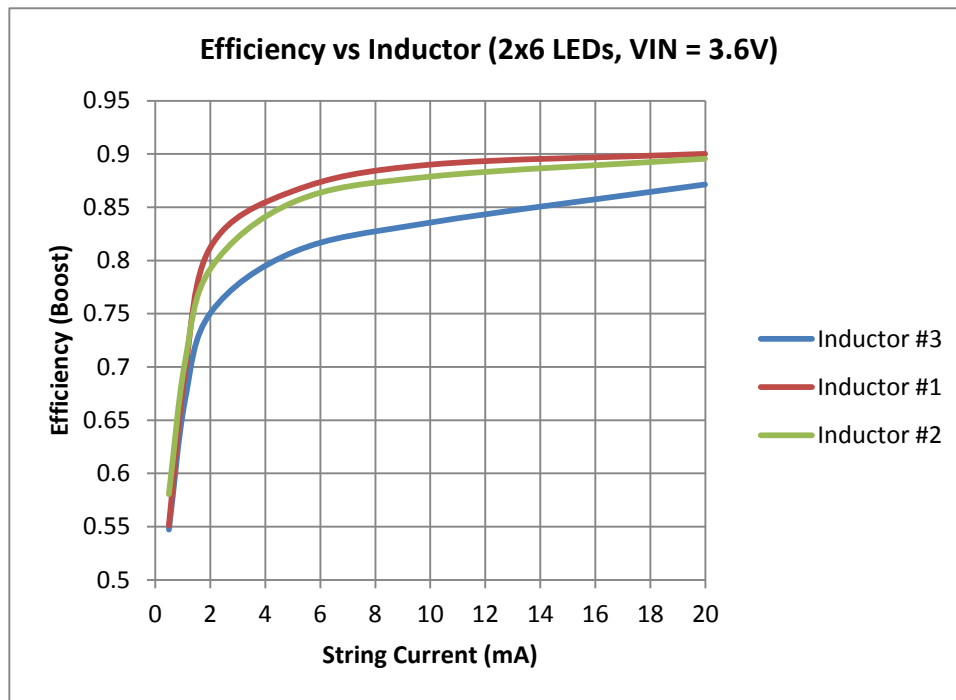

Figure 9. Measured Efficiency for Example Inductors

Another way to look at the light load performance between two inductors is to observe their response during the off time of the DCM waveform. Higher Q inductors (lower R(S)) show less damping on the switching node (see [Figure 10](#))

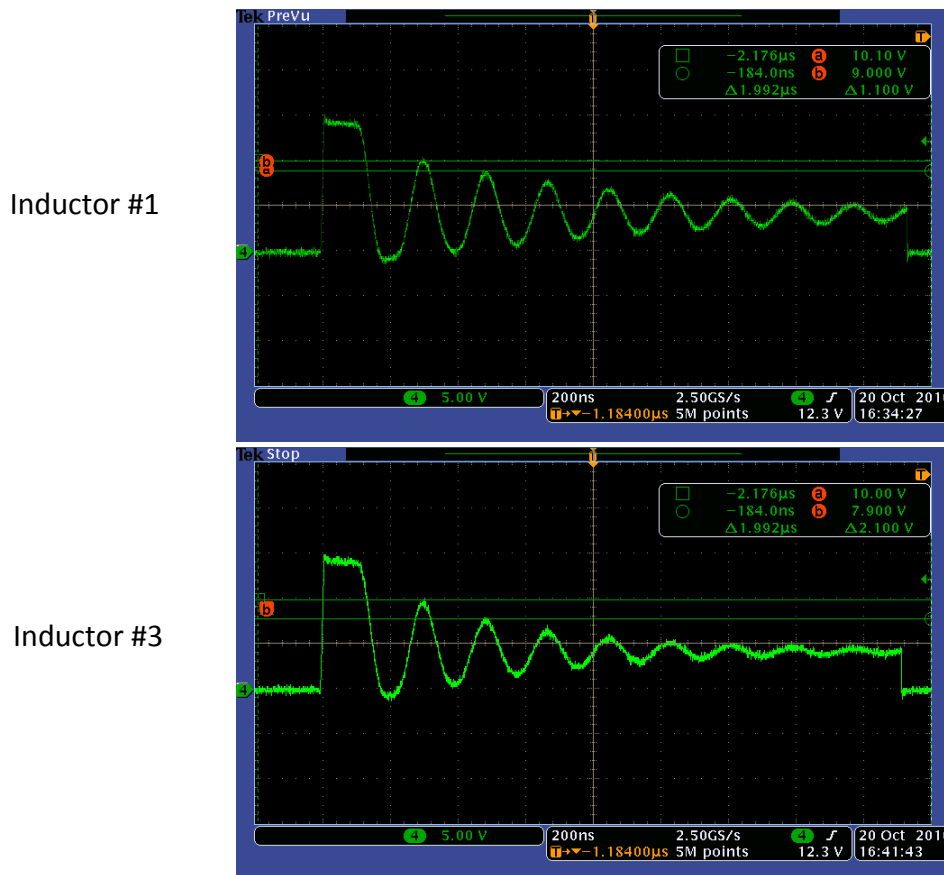

Figure 10. Damping Effect Between Different Inductors

4 Other Inductor Information

4.1 Inductor Dot Covention

Some inductors contain a dot marking on their top; generally this is with un-shielded inductors. The purpose of the dot is to indicate the side with the outer winding. The non-dotted side would be the end of the winding that is closest to the core. This can be useful for reducing the radiated magnetic field since the inductor winding can act as a shield. If an inductor has a dot, tie this end to the fixed voltage side (V_{OUT} in a boost). The other end connects to the switching node which detects the most dv/dt and benefits the most from the shielding effect of the windings.

4.2 Shielded vs Non Shielded

Generally, a shielded inductor is the best option. Shielding means the inductor core material is continuous (unbroken) around the inductor windings. This ensures that the magnetic field is contained within the core material and flux lines do not radiate out and into nearby conductors.

IMPORTANT NOTICE

Texas Instruments Incorporated and its subsidiaries (TI) reserve the right to make corrections, enhancements, improvements and other changes to its semiconductor products and services per JESD46, latest issue, and to discontinue any product or service per JESD48, latest issue. Buyers should obtain the latest relevant information before placing orders and should verify that such information is current and complete. All semiconductor products (also referred to herein as "components") are sold subject to TI's terms and conditions of sale supplied at the time of order acknowledgment.

TI warrants performance of its components to the specifications applicable at the time of sale, in accordance with the warranty in TI's terms and conditions of sale of semiconductor products. Testing and other quality control techniques are used to the extent TI deems necessary to support this warranty. Except where mandated by applicable law, testing of all parameters of each component is not necessarily performed.

TI assumes no liability for applications assistance or the design of Buyers' products. Buyers are responsible for their products and applications using TI components. To minimize the risks associated with Buyers' products and applications, Buyers should provide adequate design and operating safeguards.

TI does not warrant or represent that any license, either express or implied, is granted under any patent right, copyright, mask work right, or other intellectual property right relating to any combination, machine, or process in which TI components or services are used. Information published by TI regarding third-party products or services does not constitute a license to use such products or services or a warranty or endorsement thereof. Use of such information may require a license from a third party under the patents or other intellectual property of the third party, or a license from TI under the patents or other intellectual property of TI.

Reproduction of significant portions of TI information in TI data books or data sheets is permissible only if reproduction is without alteration and is accompanied by all associated warranties, conditions, limitations, and notices. TI is not responsible or liable for such altered documentation. Information of third parties may be subject to additional restrictions.

Resale of TI components or services with statements different from or beyond the parameters stated by TI for that component or service voids all express and any implied warranties for the associated TI component or service and is an unfair and deceptive business practice. TI is not responsible or liable for any such statements.

Buyer acknowledges and agrees that it is solely responsible for compliance with all legal, regulatory and safety-related requirements concerning its products, and any use of TI components in its applications, notwithstanding any applications-related information or support that may be provided by TI. Buyer represents and agrees that it has all the necessary expertise to create and implement safeguards which anticipate dangerous consequences of failures, monitor failures and their consequences, lessen the likelihood of failures that might cause harm and take appropriate remedial actions. Buyer will fully indemnify TI and its representatives against any damages arising out of the use of any TI components in safety-critical applications.

In some cases, TI components may be promoted specifically to facilitate safety-related applications. With such components, TI's goal is to help enable customers to design and create their own end-product solutions that meet applicable functional safety standards and requirements. Nonetheless, such components are subject to these terms.

No TI components are authorized for use in FDA Class III (or similar life-critical medical equipment) unless authorized officers of the parties have executed a special agreement specifically governing such use.

Only those TI components which TI has specifically designated as military grade or "enhanced plastic" are designed and intended for use in military/aerospace applications or environments. Buyer acknowledges and agrees that any military or aerospace use of TI components which have **not** been so designated is solely at the Buyer's risk, and that Buyer is solely responsible for compliance with all legal and regulatory requirements in connection with such use.

TI has specifically designated certain components as meeting ISO/TS16949 requirements, mainly for automotive use. In any case of use of non-designated products, TI will not be responsible for any failure to meet ISO/TS16949.

Products

Audio	www.ti.com/audio
Amplifiers	amplifier.ti.com
Data Converters	dataconverter.ti.com
DLP® Products	www.dlp.com
DSP	dsp.ti.com
Clocks and Timers	www.ti.com/clocks
Interface	interface.ti.com
Logic	logic.ti.com
Power Mgmt	power.ti.com
Microcontrollers	microcontroller.ti.com
RFID	www.ti-rfid.com
OMAP Applications Processors	www.ti.com/omap
Wireless Connectivity	www.ti.com/wirelessconnectivity

Applications

Automotive and Transportation	www.ti.com/automotive
Communications and Telecom	www.ti.com/communications
Computers and Peripherals	www.ti.com/computers
Consumer Electronics	www.ti.com/consumer-apps
Energy and Lighting	www.ti.com/energy
Industrial	www.ti.com/industrial
Medical	www.ti.com/medical
Security	www.ti.com/security
Space, Avionics and Defense	www.ti.com/space-avionics-defense
Video and Imaging	www.ti.com/video

TI E2E Community

e2e.ti.com