

设计指南: TIDA-01628

汽车仪表组驱动器通知功能参考设计



说明

此参考设计实现了汽车仪表组中常见的电源和驱动器通知功能。该设计采用电池反向保护,支持低至 3.5 伏冷启动电池电压条件的预升压级,适用于 3.3V 和 5V 电源的降压稳压器,用于提供通知的音频放大器电路,具有自动亮度控制的 LED 背光电源和适用于告警 LED 且具有灵活诊断功能的 LED 驱动器。

资源

TIDA-01628	设计文件夹
LM74700-Q1	产品文件夹
LM5150-Q1	产品文件夹
LMR33630-Q1	产品文件夹
LM43602-Q1	产品文件夹
TLC6C5816-Q1	产品文件夹
TPS61193-Q1	产品文件夹
TPA6211A1-Q1	产品文件夹
OPA320-Q1	产品文件夹
MSP-EXP430F5529LP	工具文件夹

特性

- 支持 3.5V 冷启动和 40V 负载突降的宽输入电压范围
- 具有可配置故障诊断功能的告警 LED 驱动器
- 用于提示和警告的 5V 单轨音频放大器
- 带光传感器的可调节环境背光亮度
- 用于降低功率耗散的低损耗电池反向保护

应用

- 具有动态图形支持功能的混合仪表盘
- 具有信息图表支持功能的混合仪表盘
- 可重新配置的数字仪表盘

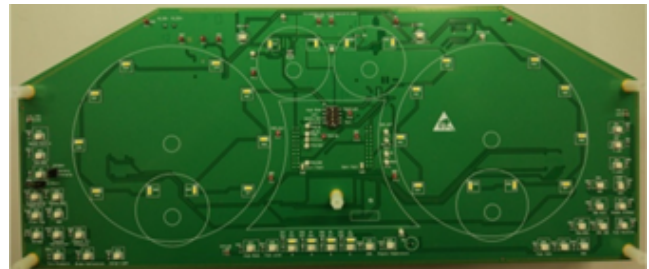

[Search Our E2E™ support forums](#)

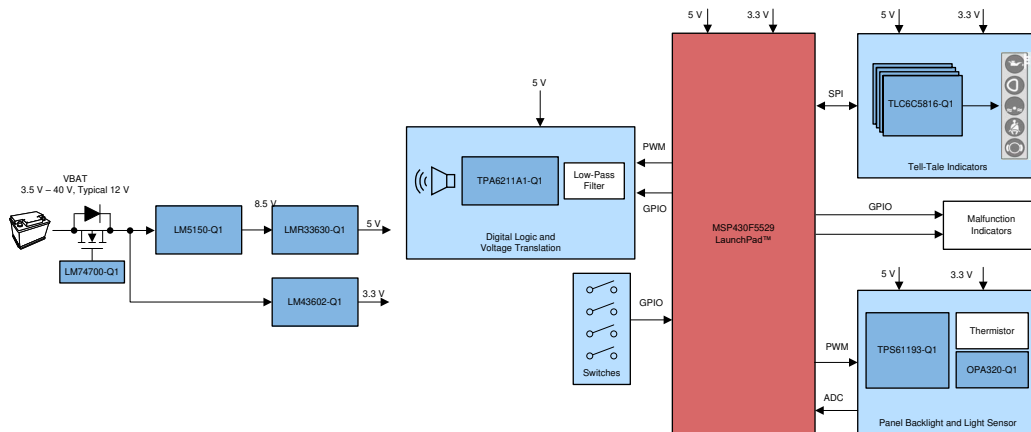

该 TI 参考设计末尾的重要声明表述了授权使用、知识产权问题和其他重要的免责声明和信息。

1 System Description

The TIDA-01628 reference design implements power and driver notification functions typically found in an automotive instrument cluster. The LM74700-Q1 smart diode is used to implement reverse voltage protection with low power loss. 3.3-V power is provided by an LM43602-Q1 buck regulator. 5-V power is provided by an LMR33630-Q1 regulator. To insure that the system works at battery voltages less than 5 V, an LM5150-Q1 boost converter boosts the LMR33630-Q1 input voltage to 8.5 V when the battery voltage drops below 8.5 V.

The TIDA-01628 control is provided by an MSP430F5529 LaunchPad™. Instrument panel backlighting is provided by a TPS61193-Q1 device. A PWM signal from the MSP430™ MCU controls the brightness of the backlighting. A photodiode output is amplified by an OPA320Q-Q1 op amp and sampled by the MSP430 to set the backlight level. Tell-tale lights are driven by TLC6C5816-Q1 LED drivers controlled by the MSP430. Cluster audio is provided by a TPA6211A1-Q1 class AB audio amplifier.

This design guide covers key component selection, circuit design, software design, system calibration, and measurement setup.

1.1 Key System Specifications

表 1. Key System Specifications

PARAMETER	SPECIFICATIONS	DETAILS
Power supply	Input voltage	Min: 3.5 V, Typ: 12 V, Max: 40 V
Tell-tale LED driver	LED Current per Channel	20 mA
Backlighting LED driver	LED Current per Channel	50 mA
Audio amplifier	Amplifier Gain	1.48 V/V

2 System Overview

2.1 Block Diagram

图 1. TIDA-01628 Block Diagram

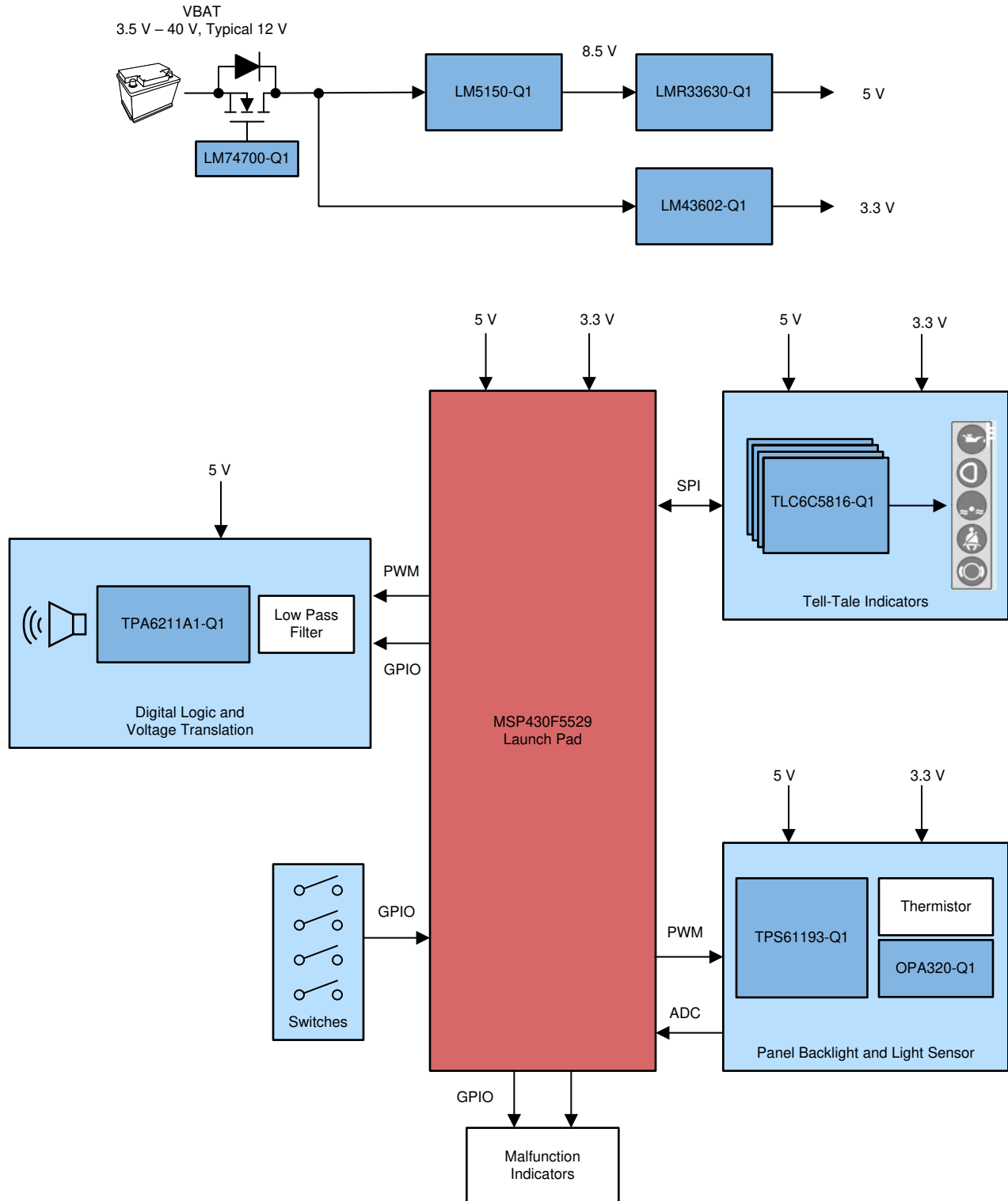

2.2 Highlighted Products

This reference design features the following devices:

- LM74700-Q1: Low I_Q , always-on, smart diode controller
- LM5150-Q1: Wide V_{IN} automotive low I_Q boost controller
- LMR33630-Q1: Synchronous buck converter with ultra-low EMI
- LM43602-Q1: Synchronous step-down voltage converter
- TLC6C5816-Q1: Automotive power logic 16-bit shift register LED driver with diagnostics
- TPS61193-Q1: Low-EMI, high-performance three-channel LED driver
- OPA320-Q1: Precision with zero-crossover distortion amplifier
- TPA6211A1-Q1: 3.1-W mono, fully differential, class-AB audio amplifier
- MSP-EXP430F5529LP: MSP430F5529 USB LaunchPad™ evaluation kit

2.2.1 LM74700-Q1

The LM74700-Q1 is a smart diode controller operates in conjunction with an external N-channel MOSFET as an ideal diode rectifier for low loss reverse polarity protection. The wide supply input range of 3 to 65 V allows control of many popular DC bus voltages. The device can withstand and protect the loads from negative supply voltages down to -65 V. With a low $R_{DS(on)}$ external N-channel MOSFET, a very low forward voltage drop can be achieved while minimizing the amount of power dissipated in the MOSFET. For low load currents, the forward voltage is regulated to 20 mV to enable graceful shutdown of the MOSFET. External MOSFETs with 5 V or lower threshold voltage are recommended. With the enable pin low, the controller is off and draws approximately 3 μ A of current.

图 2. LM74700-Q1 Functional Block Diagram

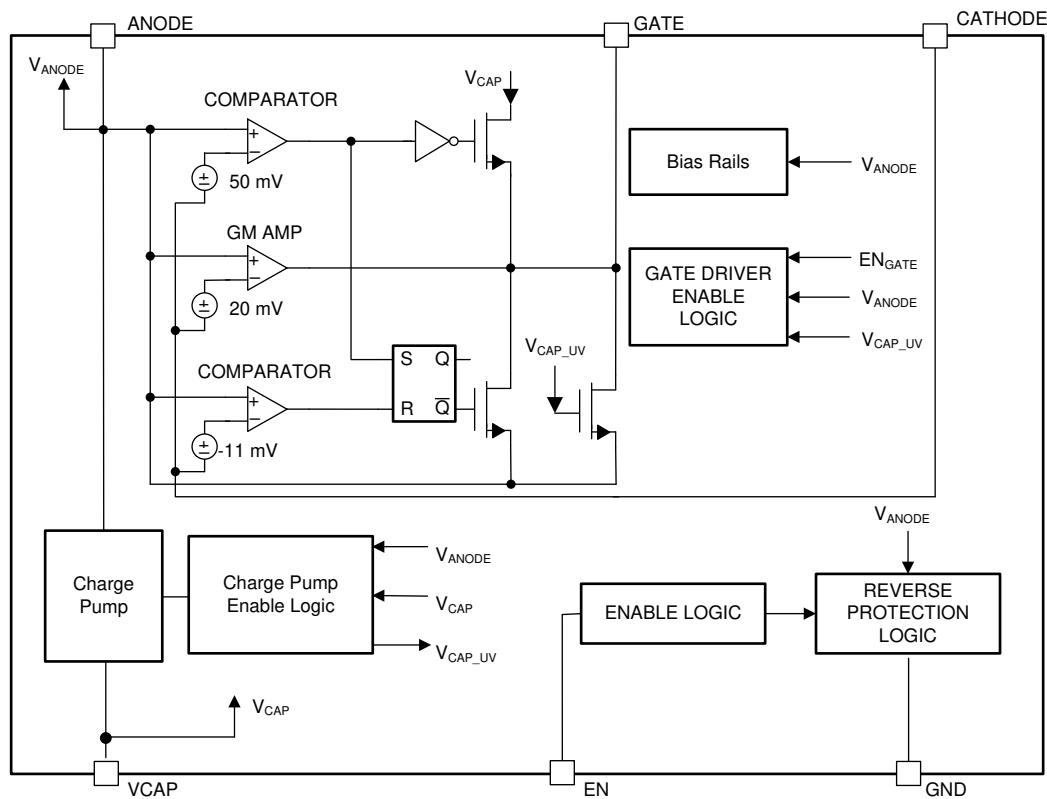

Copyright © 2017, Texas Instruments Incorporated

2.2.2 LM5150-Q1

The LM5150-Q1 device is a wide input range automatic boost controller. The device is suitable for use as a pre-boost converter which maintains the output voltage from a vehicle battery during automotive cranking or from a back-up battery during the loss of vehicle battery.

The LM5150-Q1 switching frequency is programmed by a resistor from 220 kHz to 2.2 MHz. Fast switching minimizes AM band interference, allows for a small solution size and fast transient response.

The LM5150-Q1 operates in low I_Q standby mode when the input or output voltage is above the preset standby thresholds and automatically wakes up when the output voltage drops below the preset wake-up threshold.

图 3. LM5150-Q1 Functional Block Diagram

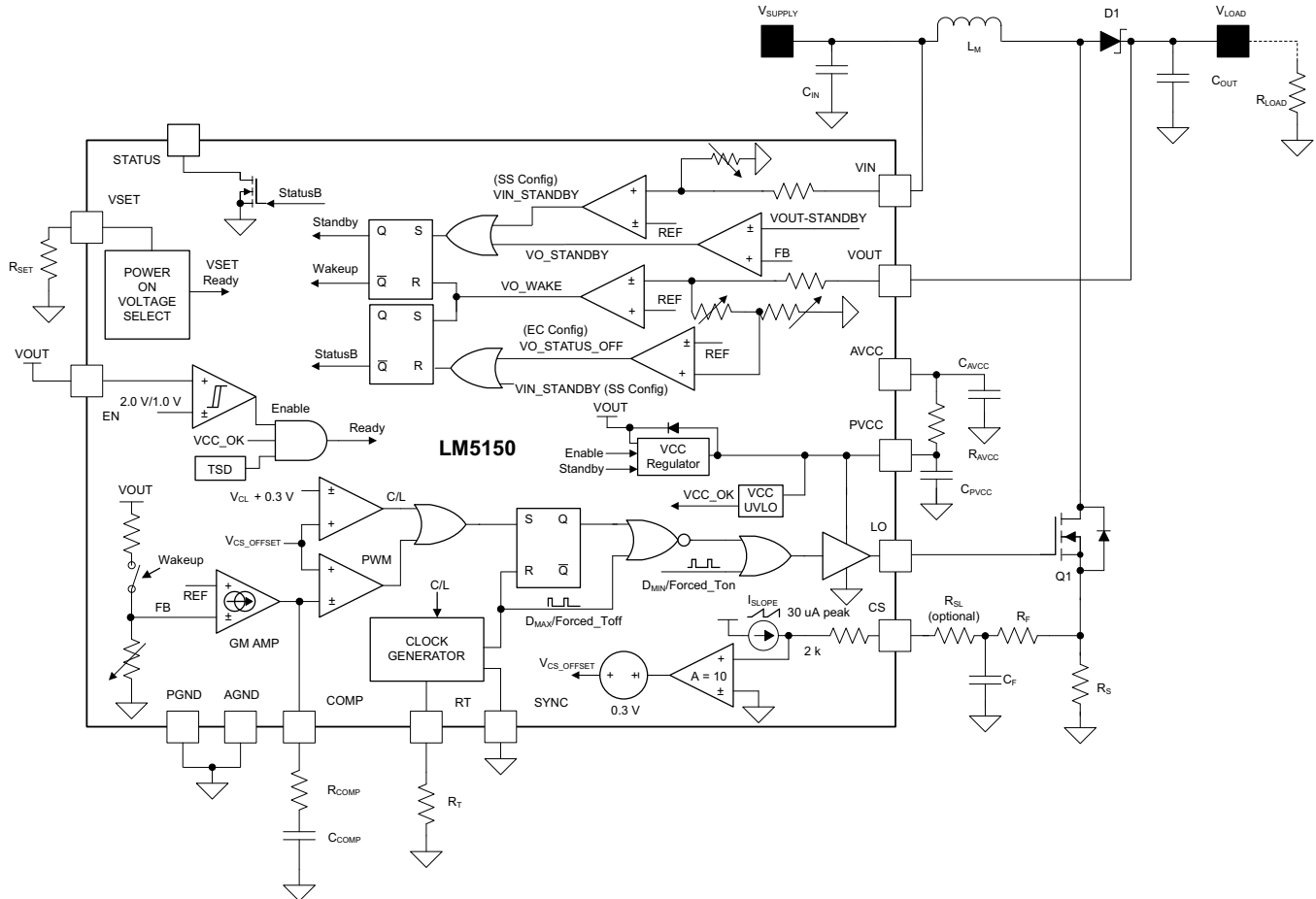

2.2.3 LMR33630-Q1

The LMR33630-Q1 is an easy-to-use, synchronous, step-down DC/DC converter that delivers best in class efficiency for rugged industrial applications. The LMR33630 is capable of driving up to 3 A of load current from an input of up to 36 V. The LMR33630 provides high light load efficiency and output accuracy in a very small solution size. Features such as a power-good flag and precision enable provide both flexible and easy-to-use solutions for a wide range of applications.

The LMR33630 automatically folds back frequency at light load to improve efficiency. Integration eliminates most external components and provides a pinout designed for simple PCB layout.

Protection features include thermal shutdown, input under-voltage lockout, cycle-by-cycle current limit, and hiccup short-circuit protection.

图 4. LMR33630-Q1 Functional Block Diagram

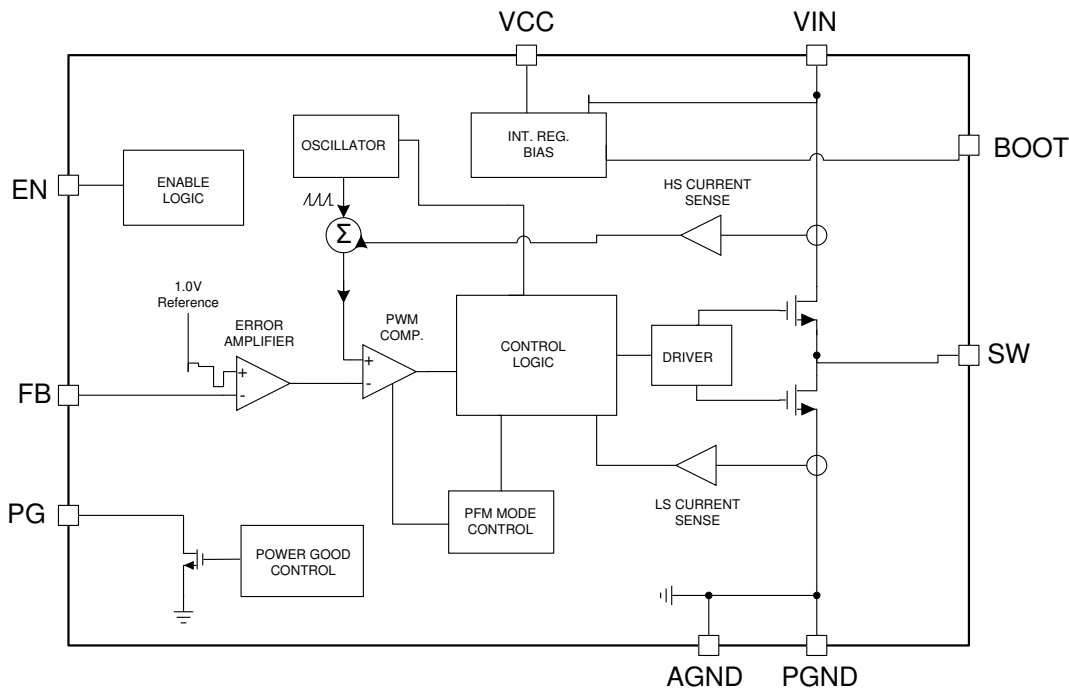

2.2.4 LM43602-Q1

The LM43602-Q1 regulator is an easy-to-use synchronous step-down DC/DC converter capable of driving up to 2 A of load current from an input voltage ranging from 3.5 V to 36 V (42 V absolute maximum). The LM43602-Q1 provides exceptional efficiency, output accuracy and dropout voltage in a very small solution size. An extended family is available in 0.5-A, 1-A, and 3-A load current options in pin-to-pin compatible packages. Peak current mode control is employed to achieve simple control loop compensation and cycle-by-cycle current limiting. Optional features such as programmable switching frequency, synchronization, power-good flag, precision enable, internal soft-start, extendable soft-start, and tracking provide a flexible and easy to use platform for a wide range of applications. Discontinuous conduction and automatic frequency modulation at light loads improve light load efficiency. The family requires few external components and pin arrangement allows simple, optimum PCB layout. Protection features include thermal shutdown, VCC under-voltage lockout, cycle-by-cycle current limit, and output short-circuit protection. The LM43602-Q1 device is available in the HTSSOP (PWP) 16-pin leaded package (6.6 mm × 5.1 mm × 1.2 mm). The LM43602A-Q1 version is optimized for PFM operation and recommended for new designs. The device is pin-to-pin compatible with LM4360x and LM4600x family.

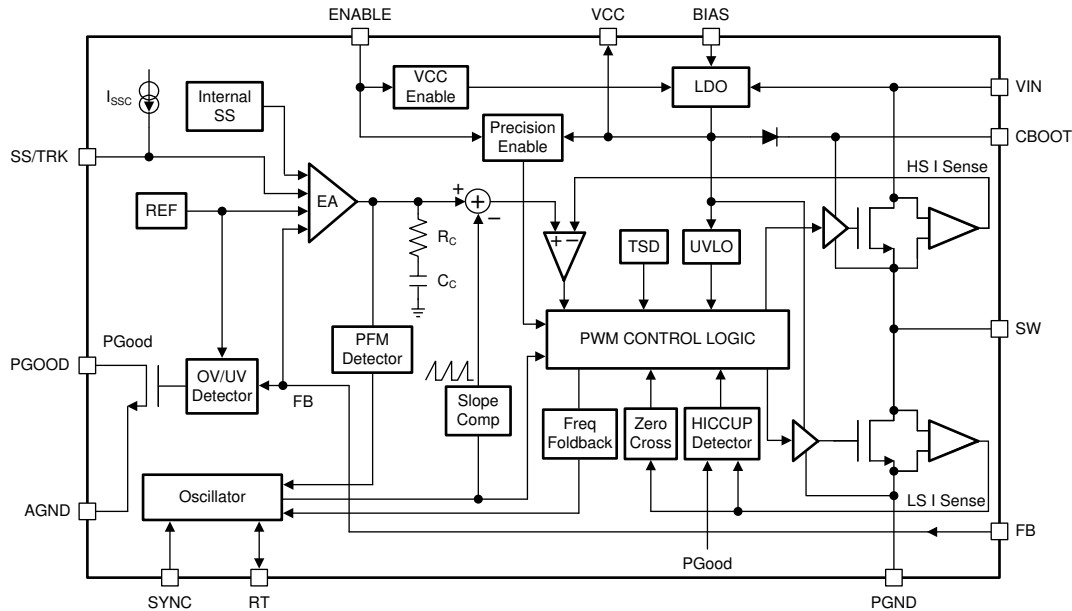
图 5. LMR43602-Q1 Functional Block Diagram

2.2.5 TLC6C5816-Q1

There are various LED indicators in automotive applications. Some applications such as hybrid instrument clusters and E-shifters have safety requirements which must have LED fault diagnostics; other applications such as HVAC panels only have an LED on-off control, which does not require LED diagnostics. To cover both applications, the TLC6C5816-Q1 device implements a flexible LED diagnostics function. By writing to the registers, the output channels can be configured with LED diagnostics features or without LED diagnostics features.

The TLC6C5816-Q1 device is a 16-bit shift register LED driver designed to support automotive LED applications. A built-in LED open and LED short diagnostic mechanism provides enhanced safety protection. The device contains 16 channels with power DMOS transistor outputs. Eight of the channels support LED fault diagnostics by configuring corresponding registers, the device can drive 16 channels without diagnostics or 8 channels with diagnostics. The diagnostics channels DIAG_n must connect to DRAIN_n to realize LED diagnostics. A command error fault implies that a channel is configured for LED diagnostics but a register write command has turned on the channel at the same time. The device provides a cyclic redundancy check to verify register values in the shift registers. In read-back mode, the device provides 6 bits of the CRC remainder. The MCU can read back the CRC remainder and check if the remainder is correct to determine whether the communication loop between MCU and device is good.

图 6. TLC6C5816-Q1 Functional Block Diagram

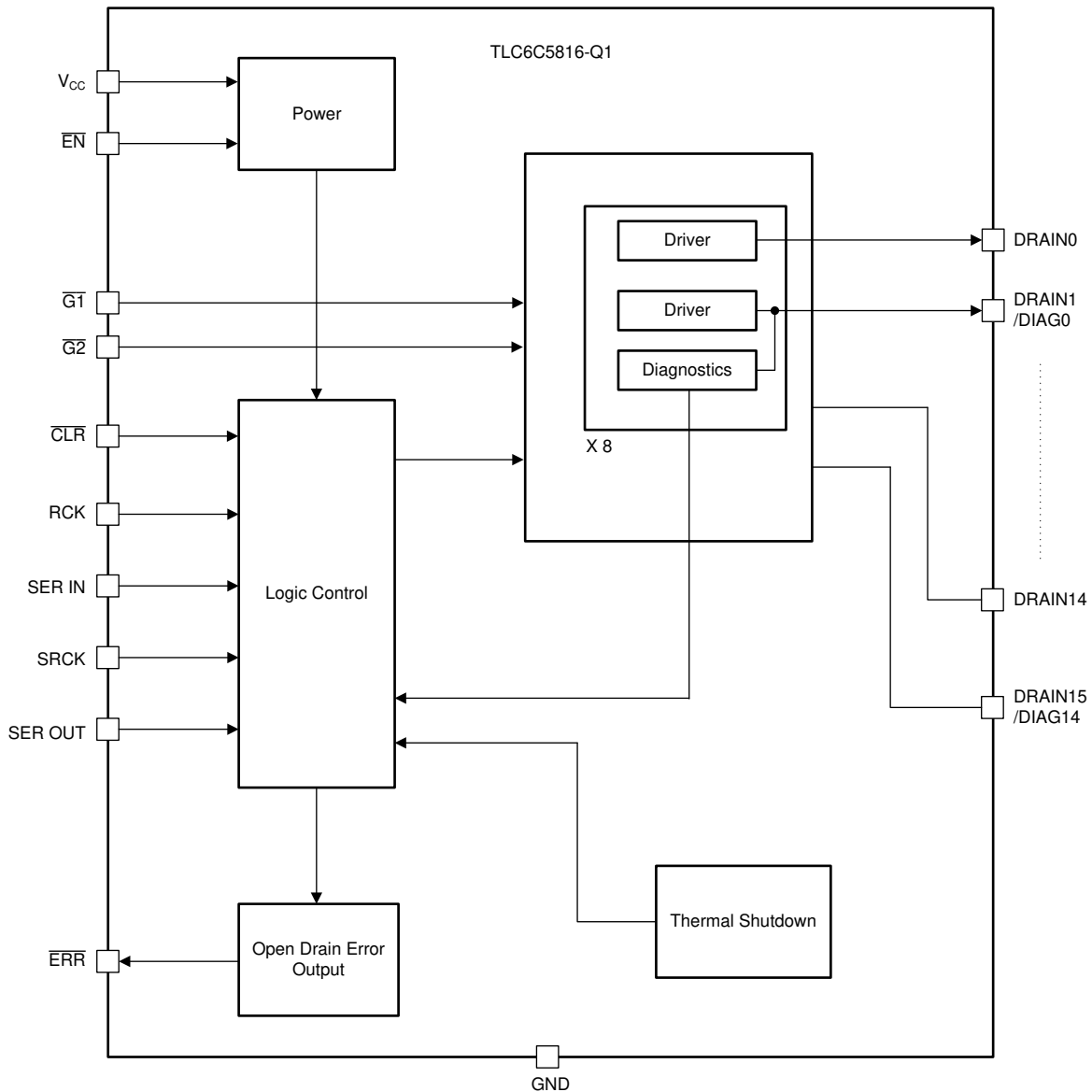

2.2.6 TPS61193-Q1

The TPS61193-Q1 is an automotive high-efficiency, low-EMI, easy-to-use LED driver with an integrated DC/DC converter. The DC/DC converter supports both boost and SEPIC mode operation. The device has three high-precision current sinks that can be combined for higher current capability.

The DC/DC converter has adaptive output voltage control based on the LED current sink headroom voltages. This feature minimizes the power consumption by adjusting the voltage to the lowest sufficient level in all conditions. For EMI reduction DC/DC supports spread spectrum for switching frequency and an external synchronization with dedicated pin. A wide-range adjustable frequency allows the TPS61193-Q1 to avoid disturbance for AM radio bands.

The input voltage range for the TPS61193-Q1 is from 4.5 V to 40 V to support automotive stop, start and load dump condition. The TPS61193-Q1 integrates extensive fault detection features.

图 7. TPS61193-Q1 Functional Block Diagram

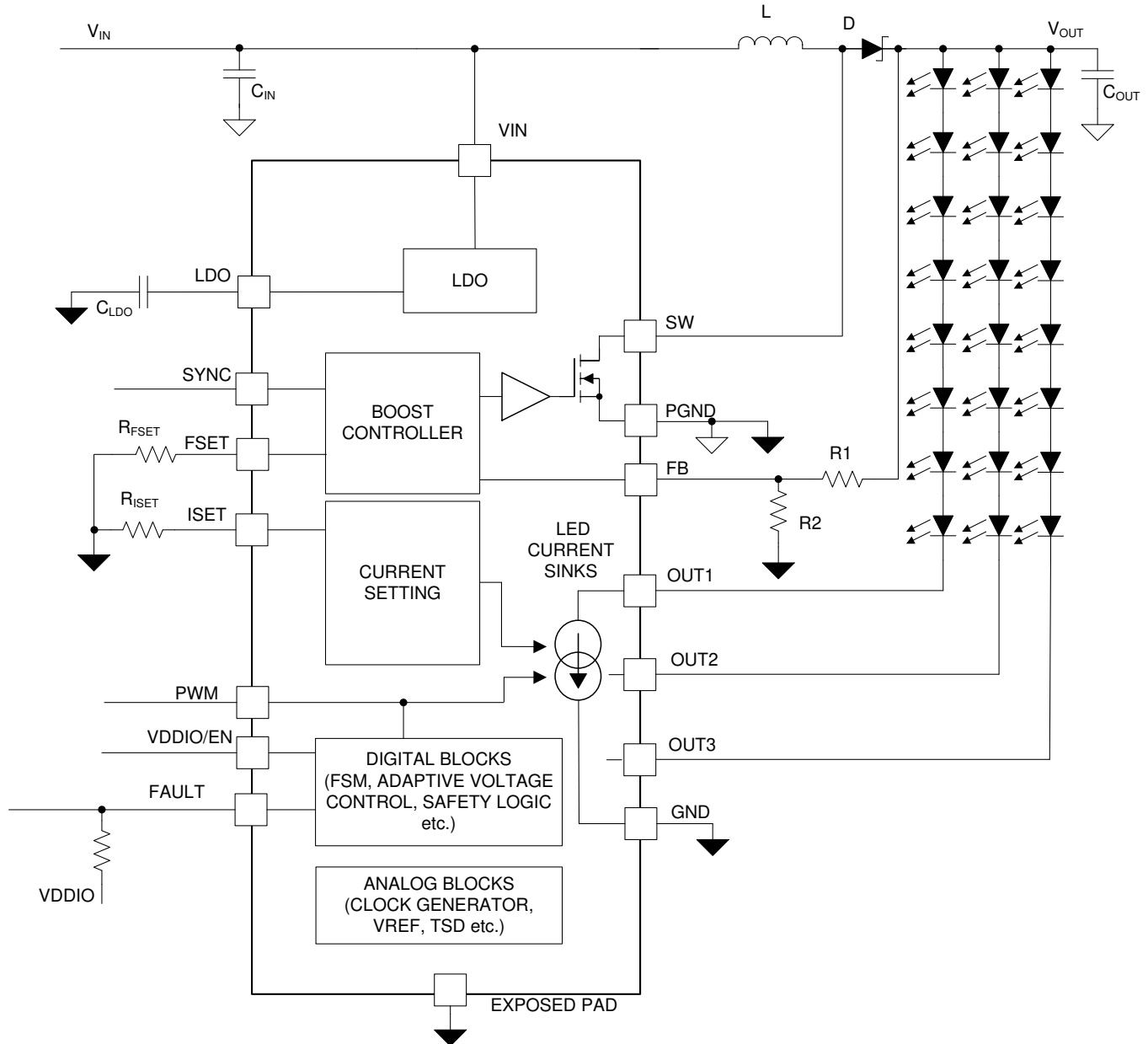

2.2.7 OPA320-Q1

The OPAX320-Q1 (OPA320-Q1, OPA2320-Q1) device is a new generation of precision low-voltage CMOS operational amplifiers (op amps) optimized for very low noise and wide bandwidth and operate on a low quiescent current of only 1.45 mA. The OPAX320-Q1 device is ideal for low-power, single-supply applications. Low-noise ($7 \text{ nV}/\sqrt{\text{Hz}}$) and high-speed operation also makes the device well-suited for driving sampling analog-to-digital converters (ADCs). Other applications include signal conditioning and sensor amplification. The OPAX320-Q1 device features a linear input stage with zero-crossover distortion that delivers excellent common-mode rejection ratio (CMRR) of 114 dB (typical) over the full input range. The

input common-mode range extends 100 mV beyond the negative and positive supply rails. The output voltage typically swings within 10 mV of the rails. In addition, the OPAx320-Q1 device has a wide supply voltage range from 1.8 to 5.5 V with excellent PSRR (106 dB) over the entire supply range, making the device suitable for precision, low-power applications that run directly from batteries without regulation. The OPAx320-Q1 device is available in an 8-pin VSSOP (DGK) package.

图 8. OPA320-Q1 Functional Block Diagram

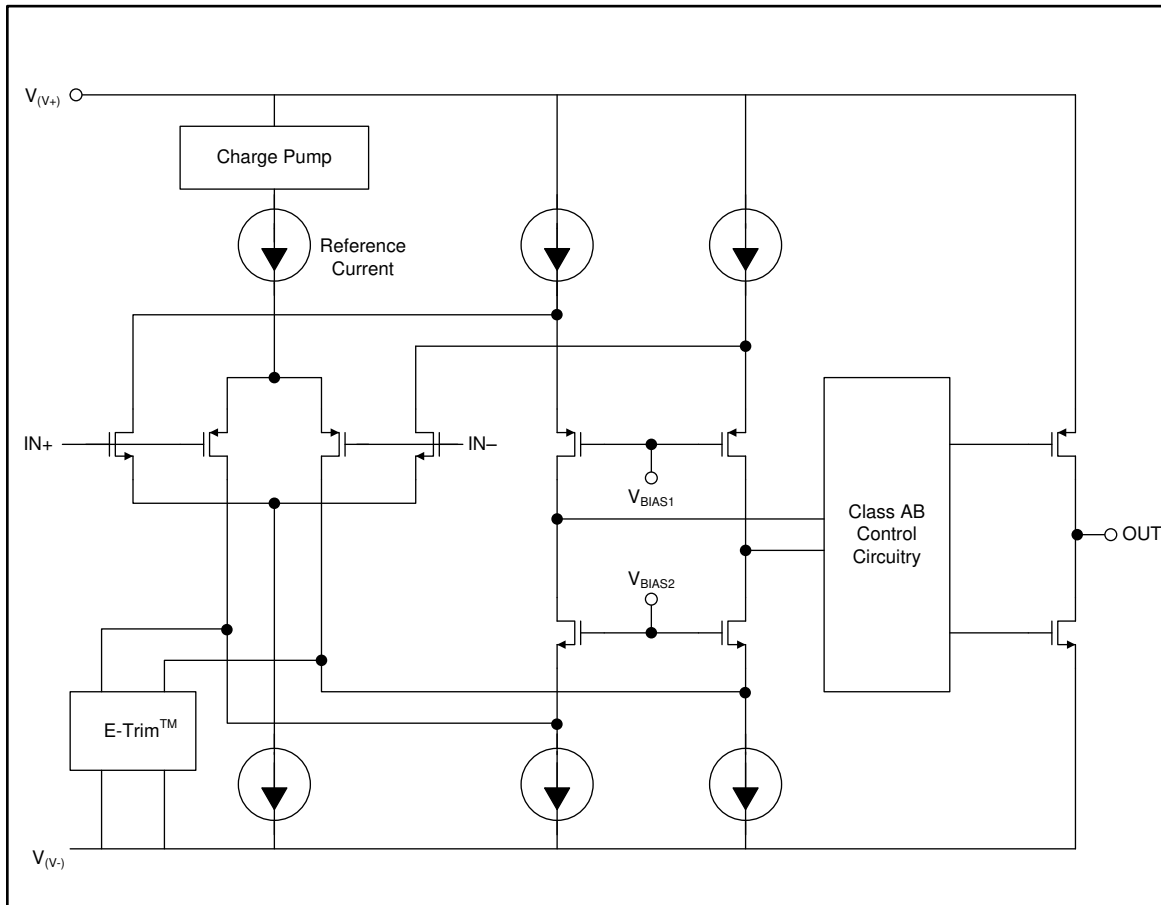

2.2.8 TPA6211A1-Q1

The TPA6211A1-Q1 device is a 3.1-W mono fully-differential amplifier designed to drive a speaker with at least 3-Ω impedance while consuming only 20-mm² total printed-circuit board (PCB) area in most applications. The device operates from 2.5 V to 5.5 V, drawing only 4 mA of quiescent supply current. The TPA6211A1-Q1 device is available in the space-saving 8-pin MSOP (DGN) PowerPAD™ package.

The device includes features such as a –80-dB supply voltage rejection from 20 Hz to 2 kHz, improved RF-rectification immunity, small PCB area, and a fast start-up with minimal pop makes the TPA6211A1-Q1 device ideal for emergency call applications. Additionally, the device supports low-power needs in infotainment and cluster applications, such as cluster chimes or driver notification.

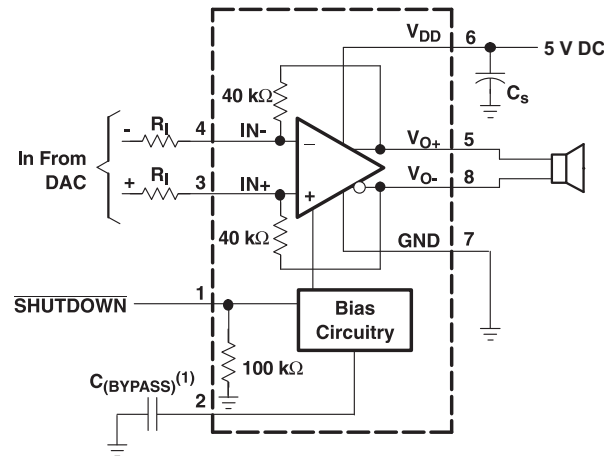
图 9. TPA6211A1-Q1 Functional Block Diagram

2.2.9 MSP-EXP430F5529LP

The MSP430 LaunchPad development kit now has USB. The MSP-EXP430F5529LP is an inexpensive and simple development kit for the MSP430F5529 USB microcontroller. It offers an easy way to start developing on the MSP430 MCU, with onboard emulation for programming and debugging as well as buttons and LEDs for a simple user interface.

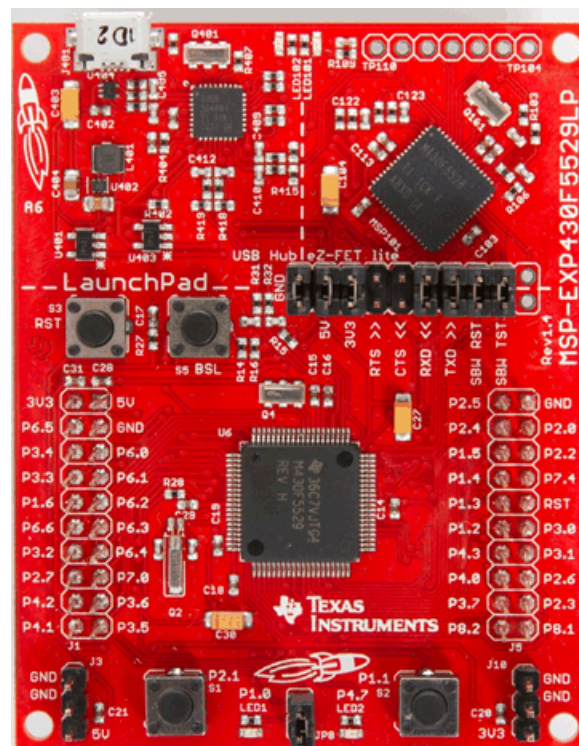
图 10. MSP430F5529 LaunchPad™ Development Kit

2.3 System Design Theory

The TIDA-01628 design has six design sections: the power supply, tell-tale LED driver, ambient light sensing with backlight adjustments, chime warnings, hardware control, and software.

2.3.1 Power Supply Design

图 11 shows the TIDA01628 power supply system. This consists of the reverse battery polarity protection, pre-boost, 5-V buck, and 3.3-V buck circuits.

2.3.1.1 Reverse Battery Polarity Protection Design

In automotive applications, the reverse polarity protection is required for electronic subsystems in vehicles as recognized by OEM standards. Most designs utilize Schottky diodes, but they cause high power losses due the voltage drop. The LM74700-Q1 is a smart diode controller that operates in conjunction with an external N-channel MOSFET. This circuit reduces power loss by acting like an ideal diode. It has a low operating I_Q of 30 μA and 3 μA for shutdown current. As the MOSFET forward voltage and threshold are low, it supports cold cranking as low as 3.5 V, which allows a 3.3-V DC/DC switching regulator or LDO to maintain regulation. In this design, the LM74700-Q1 output is connected to the input of the 3.3-V buck.

图 11. Reverse Polarity Protection Schematic

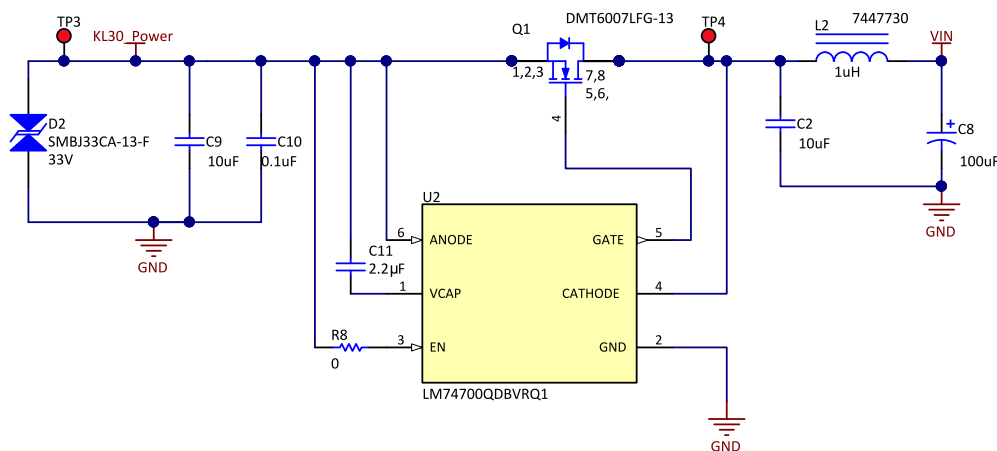

Reverse Battery Protection

2.3.1.1.1 MOSFET and TVS Diode Selection

The LM74700-Q1 data sheet details the MOSFET and diode selection for this application. The following list outlines the important MOSFET electrical parameters:

- The maximum continuous-drain current, I_D , rating must exceed the maximum continuous load current, which is less than 2.5 A in this system but could be higher than 5 A in the actual cluster system with a processor.
- The maximum drain-to-source voltage, $V_{DS(MAX)}$, must be high enough to withstand the highest differential voltage seen in this application. This would include any anticipated fault conditions. TI recommends using MOSFETs with a voltage rating up to 60 V with the LM74700-Q1.
- The $R_{DS(on)}$ is related to the forward drop voltage. Lower $R_{DS(on)}$ reduces power loss of the system. The DMT6007LFG-13 was selected as the MOSFET paired with LM74700-Q1 considering the V_{DS} , I_D , and $R_{DS(on)}$ conditions.
- The TVS diode is used for protection against transients in automotive systems. There are two key parameters for TVS diode selection: breakdown voltage and clamping voltage. In this design, one bidirectional TVS diode is used to clamp the transient voltage in a load dump case. This voltage should be lower than the MOSFET $V_{DS(MAX)}$ but higher than 24 V, which is commonly encountered during jump starting. The clamping voltage is the voltage where the TVS diode clamps into high-current mode. This

voltage should be lower than the load dump voltage to protect the other circuits, typically 36 V. SMBJ33CA-13-F was selected for this design, which has 36.7 V as the breakdown voltage and 53.3-V clamping voltage. The power levels can withstand 600-W peak power levels. This is sufficient for ISO 7637-2 pulses and suppressed load dump case (ISO-16750-2 pulse B). For unsuppressed load dumps (ISO-16750-2 pulse A) higher power TVS diodes such as SMCJ or SMDJ may be required.

2.3.1.1.2 LC Filter Design

The LC filter is designed to mitigate EMI and prevent high-frequency voltage on the power line from passing through to the power supply regulator. The [AN-2162 Simple Success With Conducted EMI From DC-DC Converters](#) application report details how to design such an LC filter. As the following shows, one simple method is to set the cutoff frequency to at least one decade below the switching frequency, [公式 1](#) shows that L2 and C2 determine the cutoff frequency of the filter.

$$F_{\text{SW}} = \frac{1}{2\pi\sqrt{L_2C_2}} \quad (1)$$

The selected inductor defines the resonant frequency of the EMI filter hence, its value is usually in the 1- μH to 10- μH range for low and medium power applications. In this design, 1 μH and 10 μF were chosen to set the cutoff frequency as 50 kHz. The damping capacitor is added to minimize the output impedance of the filter such that it does not significantly affect the loop. Usually it is recommended to choose at least 4 times the value of the input capacitor. In this design, 100 μF is chosen as the damping capacitor.

2.3.1.2 Pre-Boost Circuit Design

For an automotive 12-V battery system, the typical operating voltage range is 9 V–16 V. However, load transients result in voltages outside this range. The cold cranking requirements are needed in modern automotive systems. A pre-boost must be added to meet these critical conditions. The LM5150-Q1 device is a wide input range automatic boost controller designed specifically for e-call and start-stop systems. This reference design uses the LM5150-Q1 in start-stop mode to support the 3.5-V low input voltage range to meet the requirements of most customers. This design sets 8.5 V as the output voltage to get a higher efficiency for the total system. The boost controller is in standby mode until the input voltage is lower than 8.5 V.

The main concern for switching frequency in automotive systems is the balance of cost, efficiency, and avoiding AM broadcast frequency band to pass EMI easily. A 2.2-MHz switching frequency is set to minimize the EMI with a small and low-cost solution. The [LM5150-Q1 Wide VIN Automotive Low IQ Boost Controller](#) data sheet details design procedures for the LM5150-Q1, and the [LM5150-Q1 Boost Controller Quick Start Calculator](#) tool provides a quick start to build a board and a quick view for the circuit loop gain.

 [图 12](#) shows the pre-boost regulator schematic.

图 12. Pre-Boost Regulator Schematic



2.3.1.3 5-V Buck Design

The LMR33630-Q1 is an easy-to-use, synchronous, step-down DC/DC converter with many benefits to this design:

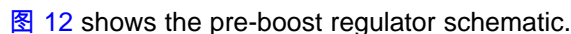
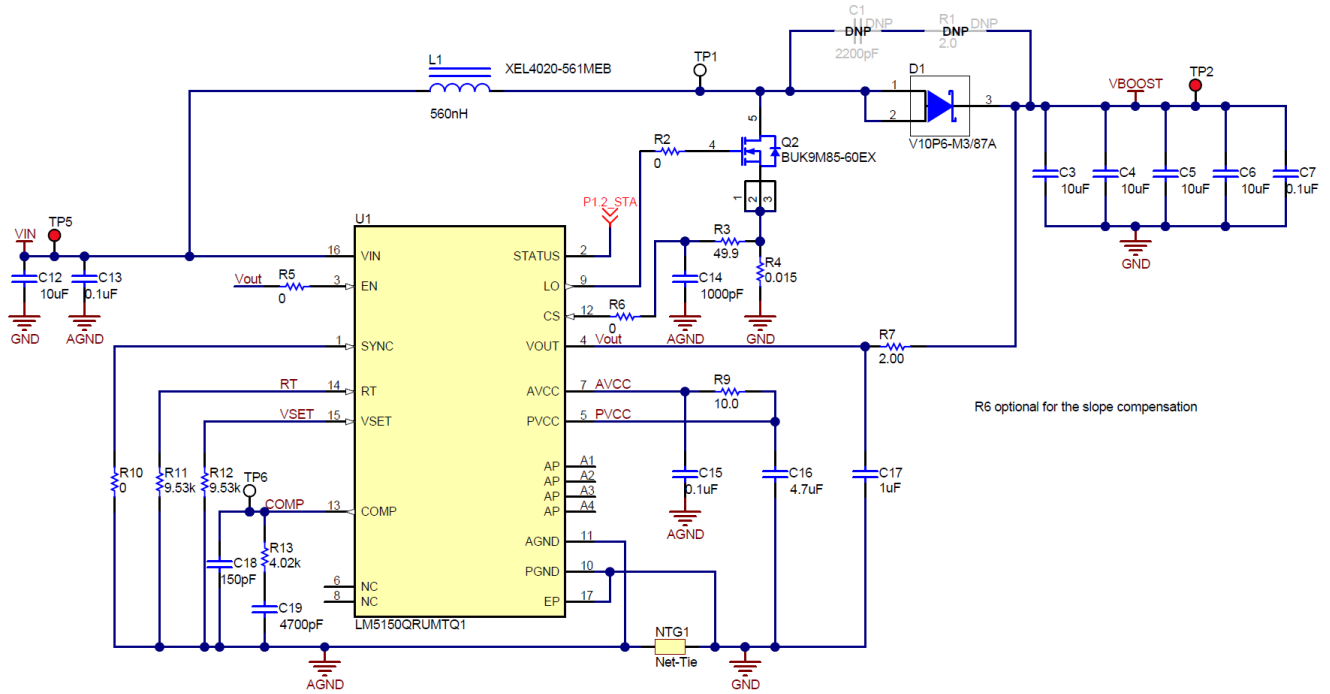
- Utilizes a 2.1-MHz switching frequency, which helps achieve high efficiency and reduction of EMI
- Automatically folds back frequency at light load to improve efficiency
- Integration also eliminates most external components and provides a pinout designed for simple PCB layout. Internal compensation eliminates the need to design compensation loop circuits.
- 图 13 shows the schematic. In this design, the enable pin is connected to VIN directly to enable the 5 V. All passive component values were chosen based on the reference design in the data sheet.

图 13. 5-V Buck Regulator Schematic

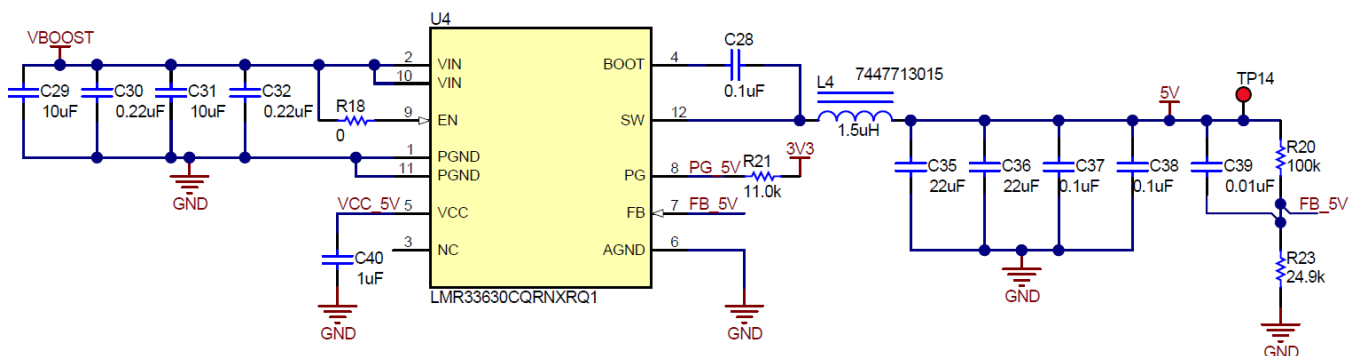

2.3.1.4 3.3-V Buck Design

A 3.3-V rail is generated by the LM43602-Q1 from the battery input. Regulating 3.3 V directly from the battery input improves system power efficiency. This is possible since the minimum input voltage is 3.5 V, which is high enough that the LM43602-Q1 can provide a regulated 3.3-V output. [LM43602-Q1 Automotive Qualified 3.5V to 36V, 2A Synchronous Step-Down Voltage Converter](#) details how to select components for the LM43602-Q1. The design features are listed as follows:

- The device is internally compensated, which reduces design time and requires fewer external components similar to the LMR33630-Q1.
- The switching frequency is programmable from 200 kHz to 2.2 MHz by an external resistor RT. In this design 2.2 MHz was chosen for better EMI performance but the option for high-efficient power conversion at lower frequency can be selected for modification.
- A wide range of frequency fold-back allows the LM43602-Q1 output voltage to stay in regulation with a much lower supply voltage V_{IN} . This leads to a lower effective dropout voltage, as most bucks cannot handle low dropout voltage considering the minimum on and off time limitation of a high-switching frequency.

图 14 shows the 3.3-V buck regulator schematic.

图 14. 3.3-V Buck Regulator Schematic

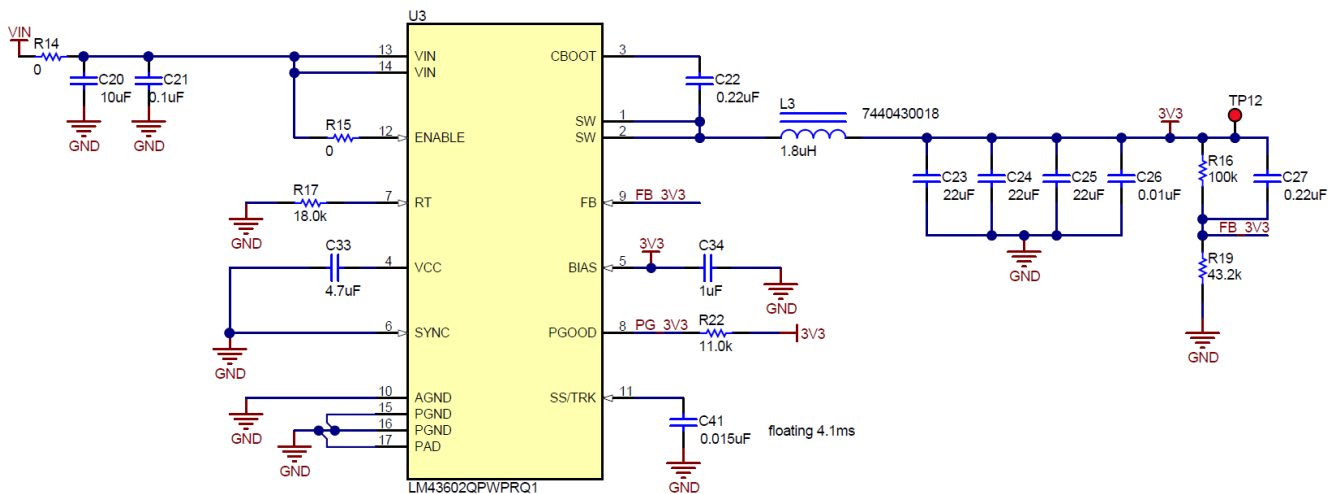

2.3.2 Tell-Tale LED Driver Design

LED indicators in an automotive cluster application show various notifications and warnings about the vehicle, such as an airbag alert, engine fault, and gear setting. Typically there are two types of LED indicators: general-purpose indicators and safety-related indicators. General-purpose indicators only require a simple turn-on and turn-off function. Safety-related indicators, such as brake system malfunction and seat belt warning require not only LED on-off control but also LED open and short diagnostics. Typically, there are more than 20 general tell-tales and about 6 safety-related tell-tales in a hybrid cluster.

图 15 shows the tell-tale led driver schematic.

图 15. Tell-Tale LED Driver Schematic

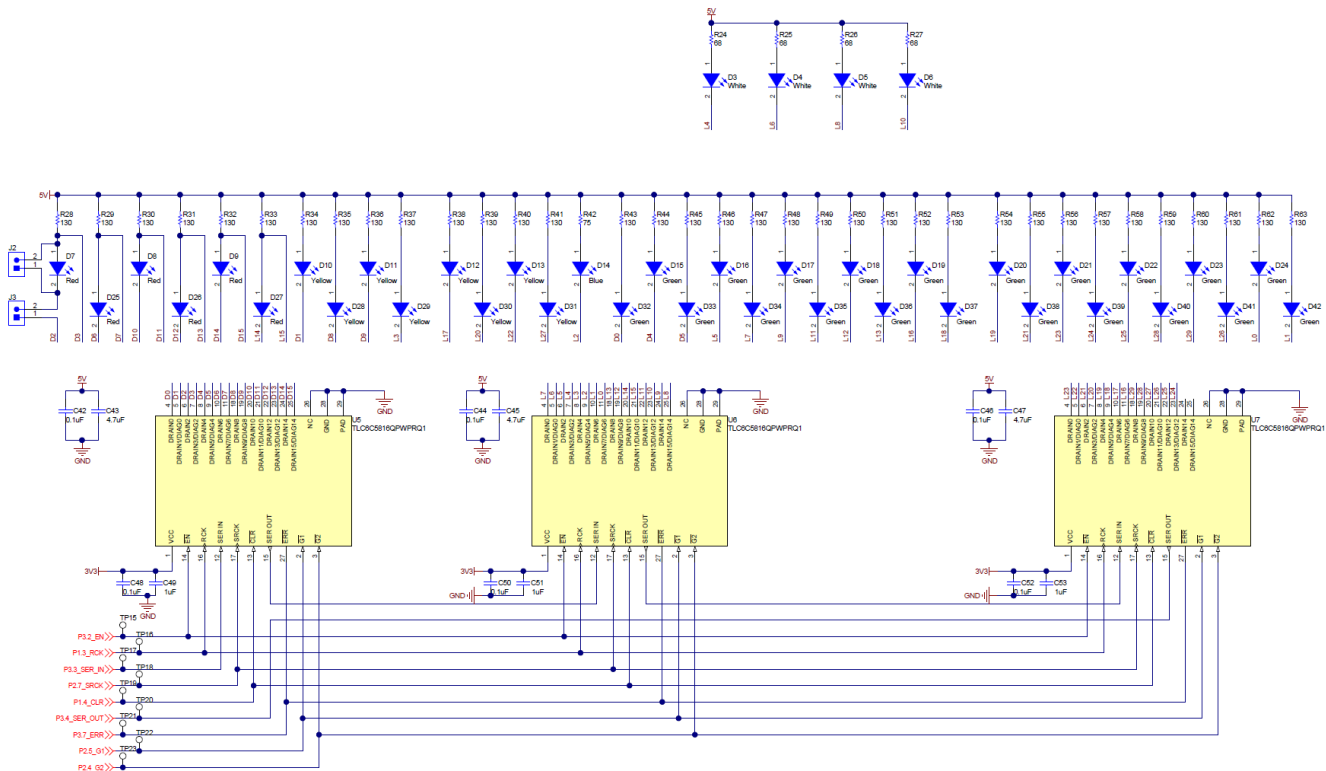

2.3.2.1 Tell-Tale LED System Configuration

The TLC6C5816-Q1 is used to drive both kinds of tell-tales in this design, which provides a flexible way to configure to 8 channels with diagnostic functions and 16 channels without diagnostics. This reference design uses 3 cascade-connected TLC6C5816-Q1 devices as 图 1 shows, to realize control of 40 LEDs with less MCU resources. The following benefits are useful for customers to utilize this device:

- Can be connected with a battery directly as the DMOS transistor maximum output voltage is 45 V
- Supports open-drain outputs up to 50 mA per channel
- Configurable LED open and short diagnostics functions allow customers to configure more flexibly, and it also has LED status read-back and cyclic redundancy check (CRC) functions to verify the value of registers, then check the errors
- Each device has 2 PWM inputs for group dimming to adjust the output current

2.3.2.2 Tell-Tale LED Current and Diagnostic Design

Typical automotive cluster applications use 5 V as the power for LEDs to get a related constant LED current. Design parameters are outlined in 表 2.

表 2. Tell-Tale Type and Number of LEDs

TYPE	LED NUMBER	CURRENT
General tell-tale	8 yellow + 1 blue + 17 green	20 mA
Safety-related tell-tale	6 red	20 mA
Gearshift tell-tale	4 white + 4 green	5 mA (white) + 20 mA (green)

The different color LEDs always represent different levels of functional safety. Red represents the highest level of functional safety, green is the lowest level, blue is for the high-beam light only, and the yellow represents mid-level tell-tales. Setting the LED current resistor depends on the LED supply voltage and the LED forward voltage. Use 公式 2 to calculate the current-setting resistor:

$$R = \frac{(9V - V_{LED})}{I_{LED}} \quad (2)$$

To demonstrate the diagnostic function, two jumpers are used for the battery indicator to simulate the open and short malfunctions. The MSP430 monitors the error pin status to determine if it needs to read-back the error. If an error is detected, the MSP430 would read back the error, determine what happened, and then report the error to the short or open indicator on the top of the board.

2.3.3 Ambient Light Sensing and Backlighting Adjustment Design

2.3.3.1 Ambient Light Sensing Circuit

This design uses a Vishay Siliconix TEMT6200FX01 as the ambient light sensor and an OPA320-Q1 as a transimpedance amplifier for the light-dependent current of the ambient light sensor. When this design is exposed to light, the ambient light sensor has a reverse current through it. This reverse current then increases the output voltage of the amplifier. In the absence of the ambient light current, the negative terminal input voltage and the output voltage could be 0 V. However, the output voltage should not reach 0 V for the single-supply amplifier as it will saturate the amplifier since the amplifier cannot drive all of the way to 0 V. A resistor divider comprised of R77 and R78 provides a bias at the positive input of the amplifier to avoid saturation. 图 16 shows the schematic.

图 16. Ambient Light Sensing Circuit Schematic

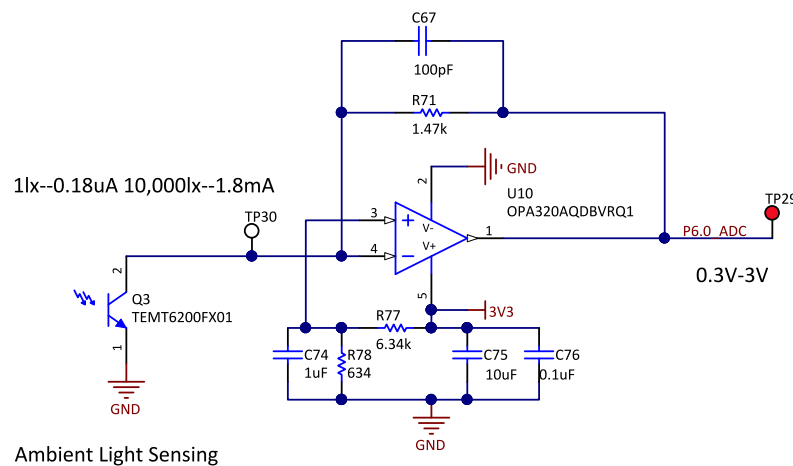

This design, as 图 16 shows, uses a 10:1 resistor divider to get a 0.3-V bias, which is sufficient for the OPA320-Q1 device to get an accurate conversion result. The basic characteristics of the TEMT6200FX01 show that the maximum photo current under 10 k Lux is about 1.8 mA and 0.18 μ A under 1 Lux. The gain resistor R71 can be defined by: 公式 3.

$$R71 = \frac{(V_{OUT(max)} - V_{OUT(min)})}{I_{IN(max)}} = \frac{(3V - 0.3V)}{1.8mA} \quad (3)$$

For this design, equation 公式 3 results in a 1.47-kΩ feedback resistor. In most cases, a feedback capacitor is necessary to maintain stability. This feedback capacitor forms a pole for the frequency response with the feedback gain resistor. Above the pole frequency, the amplification of the circuit will decline, which means the feedback capacitor C67 determines the bandwidth. Keep the capacitor at or below the value calculated by 公式 4 to keep the bandwidth requirements. This design uses a 100-pF feedback capacitor.

$$C67 \leq \frac{1}{(2\pi \times R71 \times f_{pole})} \leq \frac{1}{(2\pi \times 1.47 \times 1 \text{ MHz})} = 108 \text{ pF} \quad (4)$$

For more details, see [1 MHz, Single-Supply, Photodiode Amplifier Reference Design](#).

2.3.3.2 Backlight Circuit

Automotive hybrid cluster applications can include several analog gauges, such as a tachometer and speedometer, which use white LEDs as the backlight in most modern vehicles. Because white LEDs have larger forward voltages, eight white LEDs connected in series could potentially have a 30-V voltage drop across them. In the case of large temperature variations, the required voltage across the LED strings could reach above 36 V. SEPIC or buck-boost topologies could be used, but the performance and efficiency may change. This reference design uses an automotive high-efficiency, low-EMI TPS61193-Q1 device as the backlight LED driver. It can support a 4.5 V–40 V input voltage range, three 100-mA channels, 2.2-MHz switching frequency and the ability to enable spread spectrum switching for improved EMI response. 图 17 highlights the backlight schematic and LED arrays.

This reference design uses OSRAM KW DPLS32.EC compact LEDs, which are part of the SYNIOS E4014 family and offers an extremely low-profile and compact package design. Each LED has a typical forward voltage of 3.15 V and handles 5–180 mA forward current, which is sufficient for most backlight applications.

图 17. Backlight Schematic and LED Array

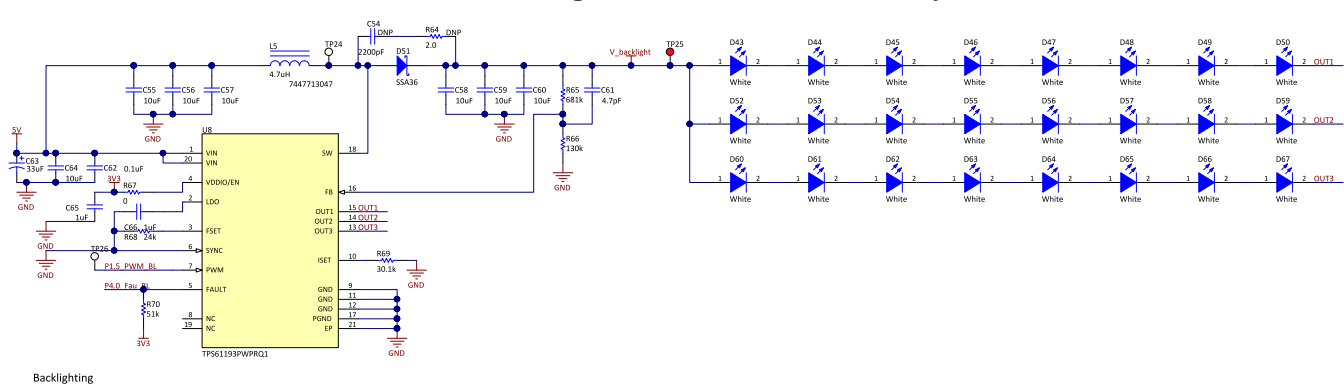

2.3.3.2.1 Maximum Output Voltage Setting

Base the maximum output voltage on the maximum LED forward voltage across each string. TI recommends setting the maximum output voltage to be 30% higher than the LED string forward voltage. The TPS61193-Q1 can automatically adjust the output voltage based on the LED sink current and headroom voltage.

$$V_{boost} = \left(\left(\frac{1.2 \text{ V}}{R66} \right) + K \times 0.0387 \right) \times R65 + 1.2 \text{ V}$$

- R66 recommended value is 130 kΩ

- Resistor values are in k Ω
 - K = 1 for maximum adaptive boost voltage
 - K = 0 for minimum adaptive boost voltage
 - K = 0.88 for initial boost voltage
- (5)

As the typical LED forward voltage is 3.15 V, and maximum forward voltage is 3.4 V, 34 V is chosen as the maximum voltage to consider with the 30% margin. In this design, K = 1 to get a maximum output voltage limitation. As a result of 公式 5, R65 is calculated to be 681 k Ω .

2.3.3.2 Switching Frequency Setting

This design uses a current mode DC/DC converter, where the inductor current is measured and controlled with the feedback. The switching frequency can be adjusted between 250 kHz and 2.2 MHz with R_{fset} resistor R68. This design uses a 2.2-MHz switching frequency, which results in a smaller inductor. When operating in the 1.8 MHz to 2.2 MHz range, the feedback capacitor C61 is set as 4.7 pF for loop stability.

$$F_{SW} = \frac{67600}{(R_{fset} + 6.4)}$$

where

- F_{sw} is the switching frequency in kHz
 - R_{fset} is the frequency setting resistor in k Ω
- (6)

2.3.3.3 Current Setting and Brightness Control

The maximum current for the LED outputs is controlled with an external R_{ISET} resistor. The R_{ISET} value for target maximum current can be calculated using 公式 7:

$$R_{ISET} = \frac{2342}{(I_{OUT} + 2.5)}$$

where

- R_{ISET} is the current setting resistor in k Ω
 - I_{OUT} is the output current per channel in mA
- (7)

Typical analog gauge cluster backlights do not require more than 50 mA of current. In this design, 80 mA is set as the maximum current. This design uses the PWM dimming function to adjust to the required current convenient for the customer's design. Using 公式 7, R69 is set to 30.1 k Ω .

A 10-kHz varying duty cycle pulse-width modulation (PWM) from the MSP430 controls the TPS61193-Q1 dimming. This reference design utilizes a logarithmic function to determine the brightness level based on the light level measured in the ambient light sensing circuit.

2.3.4 Chime Audio Amplifier

The audio chime is used for safety warnings and turning indications. The TPA6211A1-Q1 device is a simple and easy-to-design fully-differential audio power amplifier that can be used with 8- Ω or 4- Ω speakers. The TPA6211A1-Q1 is configured for a single-ended input in this design. A PWM signal or a 1-kHz square wave generated from a digital output is low-pass filtered with components R74 and C71 to approximate a sine wave. In this reference design, the gain is currently set to 3.2 V/V. Remember that

when changing the gain, the TPA6211 input capacitors (C70 and C72) form a high-pass filter with the input resistors (R73 and R75). The feedback resistors are internal to the TPA6211A1-Q1 and trimmed to 40 kΩ. In this design, the audio chime warning is produced by a MSP430 PWM signal. By passing the PWM signal through a low-pass filter, the system produces the chime warning when the signal light is turned on or when a general warning notification occurs.

图 18. Chime Audio Amplifier Schematic

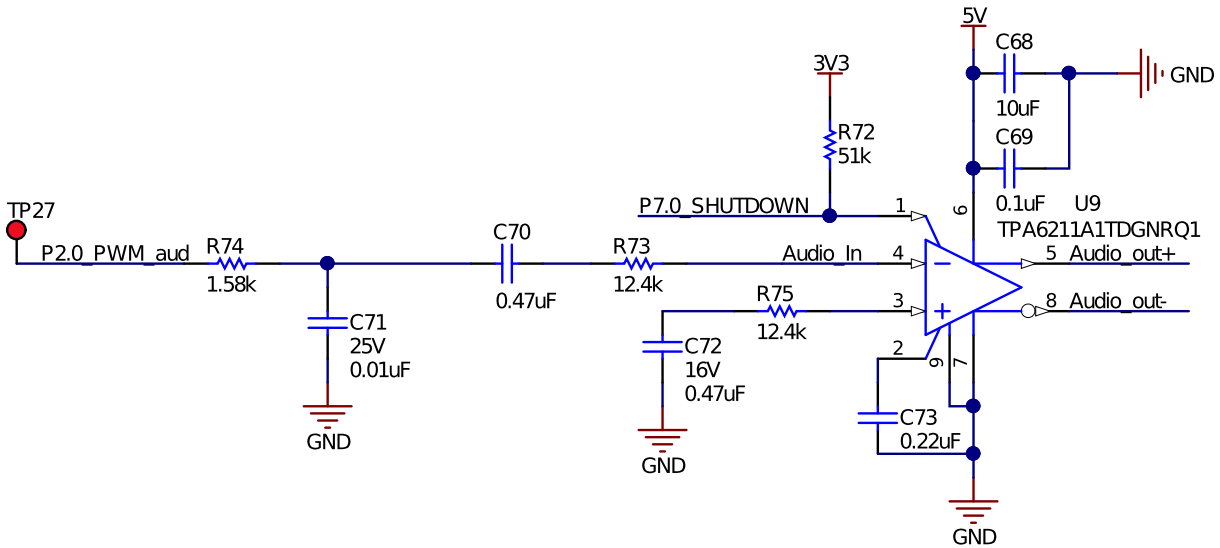

3 Hardware, Software, Testing Requirements, and Test Results

3.1 Required Hardware and Software

3.1.1 Hardware Setup

图 19 shows the top of the board which includes the ambient light sensor, the backlight LEDs, tell-tales, shunts, and DIP Switch. Backlight LEDs are distributed around the four analog gauges and the tell-tale LEDs are distributed in a typical position based on a real automotive cluster. Shunts and DIP switches must be connected properly as listed in 表 3.

图 19. TIDA-01628 Top of Board



表 3. TIDA-01628 Jumpers and DIP Switch Default Settings

JUMPER OR SWITCH	FUNCTION	DEFAULT
J1	Connect to 12-V power supply	Connected
J2	Short LED header	No jumper
J3	Open LED header	Jumper connected
J4 and J5	Connect with the MSP430	Connected
J6	Connect to speaker	Connected
S1	Simulates driving operations	Keep all switched to the right

图 20 是板的底部，MSP430 已断开。MSP430 LaunchPad 必须正确插入 J4 和 J5。图 21 显示了如何将 MSP430 连接到板的底部以及扬声器和电源的正确跳线连接。一旦软件已安装到 MSP430 上，就不需要保持 USB 电缆连接，因为 LaunchPad 由板供电。

图 20. TIDA-01628 Bottom of Board Without MSP430

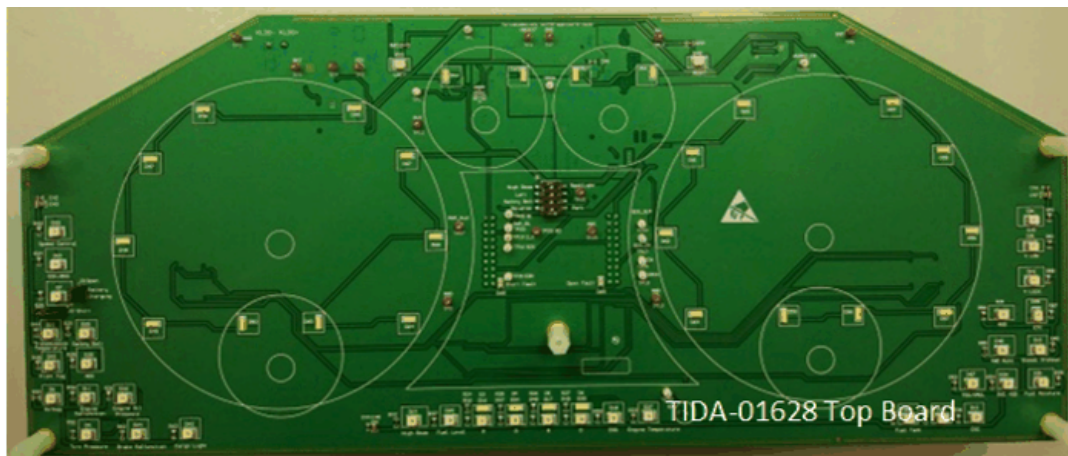

图 21. TIDA-01628 Bottom of Board Connection



3.1.2 Software

The MSP430 software is written in Code Composer Studio™ v8 with TI's [MSPDRIVERLIB](#) driver library. Its abstracted API keeps you above the bits and bytes of the MSP430 hardware by providing easy-to-use function calls. [图 22](#) shows the basic process of the TIDA-01628 software while a detailed state machine transition is outlined in [图 23](#).

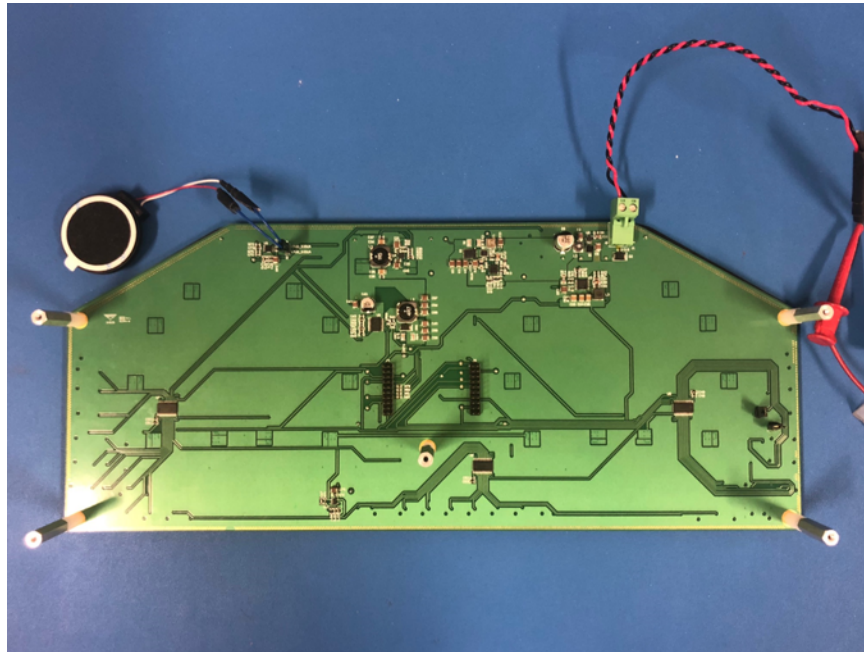
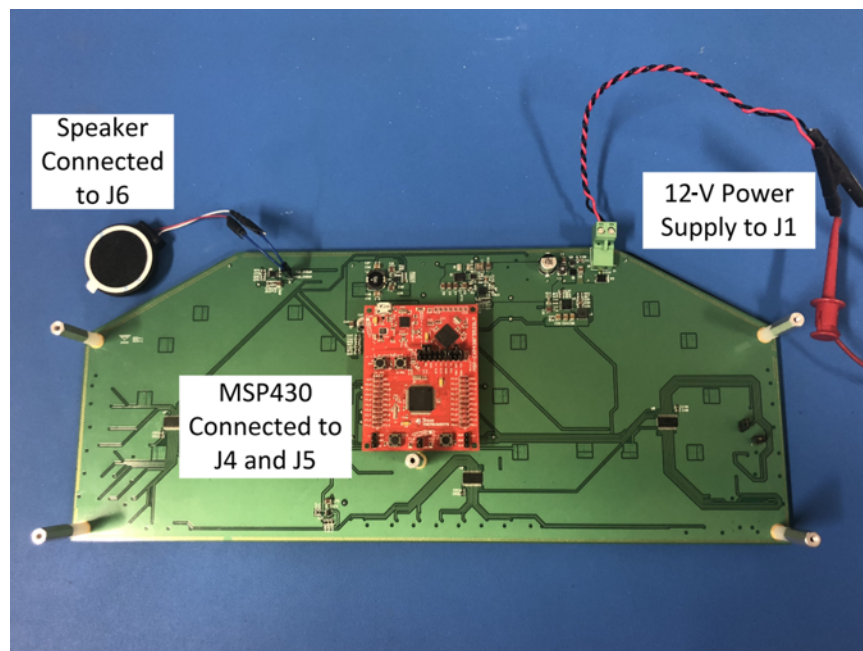
图 22. TIDA-01628 Software Basic Process



图 23. TIDA-01628 State Machine Transition Graph



图 24 depicts the correct jumpers to connect to the MSP430. Since the design already includes 3.3-V and 5-V output rails, it is not necessary to connect the jumpers on the MSP430 that provide the same rails. The SBW Reset jumper can also be left open in case the user would like to debug the system on the Code Composer Studio and test the board at the same time.

图 24. MSP430 Jumpers

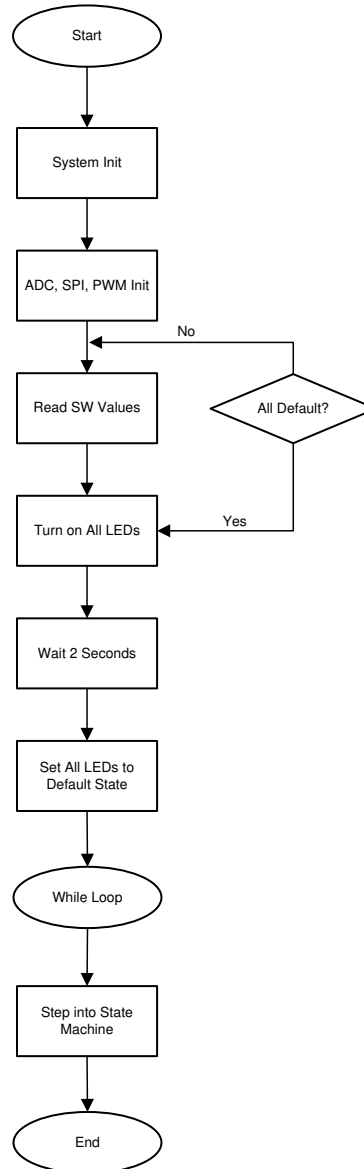

3.2 Testing and Results

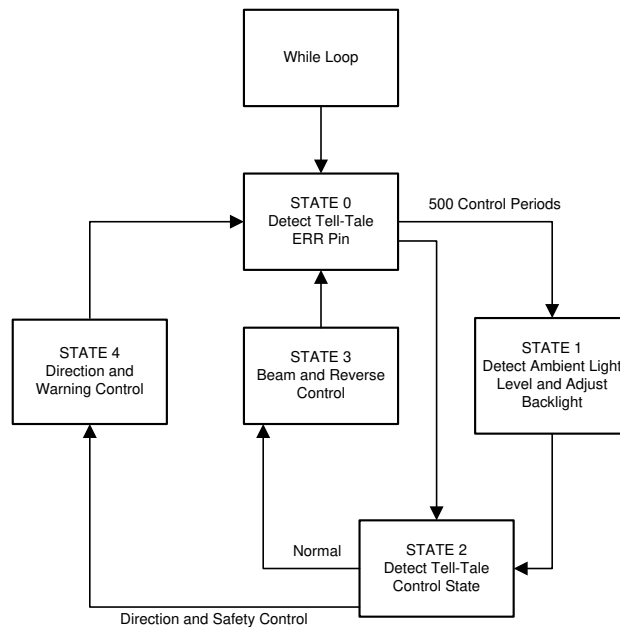
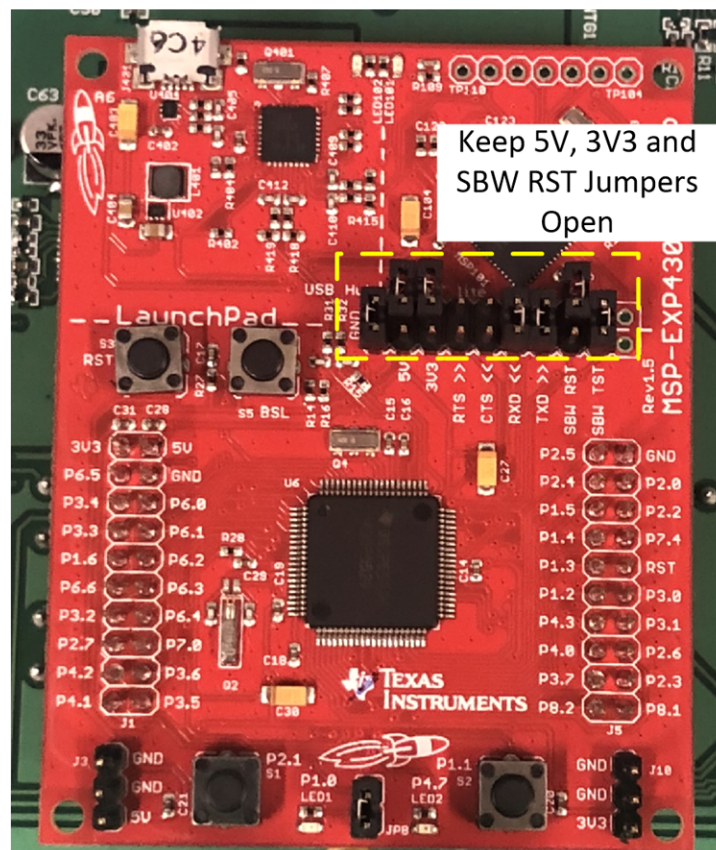
Testing was performed on this board to highlight its performance during normal startup and through cold cranking conditions. The jumpers and DIP Switch are used to demonstrate the tell-tale diagnostic functions. The relationship between the backlight brightness and backlight PWM duty are also highlighted in this section.

3.2.1 Test Setup

The test setup follows:

1. Plug the MSP430 in the proper orientation as highlighted in [节 3.1.1](#).
2. Move all S1 switches to the right to ensure all pins are in the low state.
3. Keep a jumper connected to J3 and keep J2 disconnected.
4. Connect J1 to a 12-V power supply, then supply power to the board.
5. Connect a USB cable between the board and computer.
6. Open Code Composer Studio and download the proper software from [TIDA-01628](#).
7. Open the project from Code Composer Studio and compile.
8. Stop running the project, then disconnect the USB cable.
9. Reset the MSP430 via the S3 button the board to begin using the cluster system.

See [图 20](#) and [图 21](#) for the hardware test setup images.

3.2.2 Test Results

3.2.2.1 Power Supply Testing

[图 25](#) shows typical turn on at $V_{IN} = 12\text{ V}$ and also highlights its ability to work at lower voltages such as $V_{IN} = 5\text{ V}$.

图 25. TIDA-01628 12-V Turn On

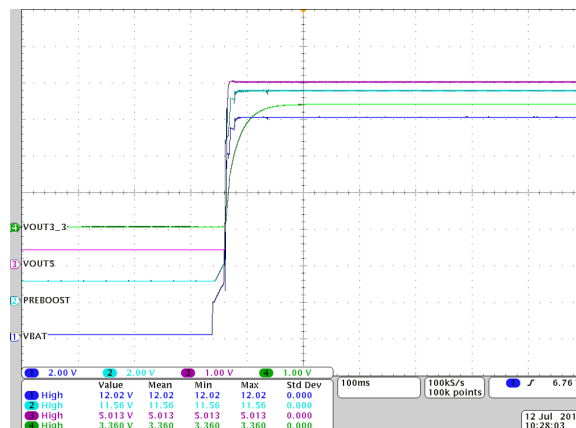

[图 26](#) shows the output voltages and the performance of the LM5150-Q1 pre-boost. To minimize output undershoot when waking up, the LM5150-Q1 boosts the V_{OUT} regulation target during the first 128 cycles after the wake-up event.

图 26. TIDA-01628 Low V_{IN} and Pre-Boost Performance



图 27 shows TIDA-01628 still outputting the proper voltage rails even as it undergoes cold cranking conditions and V_{IN} drops to 3.5 V. During cold cranking and initial VBAT voltage drop to 3.5 V, the pre-boost minimizes its output undershoot (similar to 图 26) and when the VBAT voltage goes from 6.5 V to 8.5 V, pre-boost goes into standby mode to conserve battery.

图 27. TIDA-01628 Power Supply Cold Crank Test

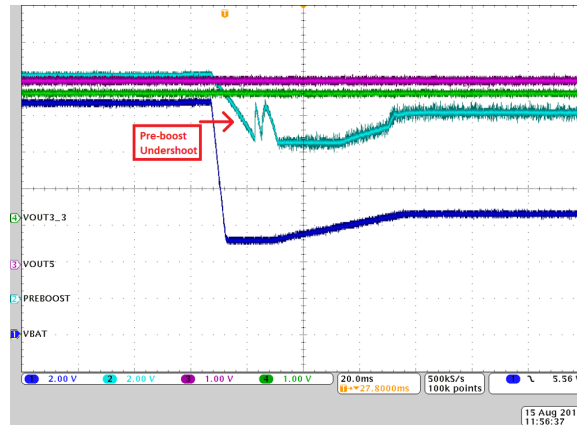
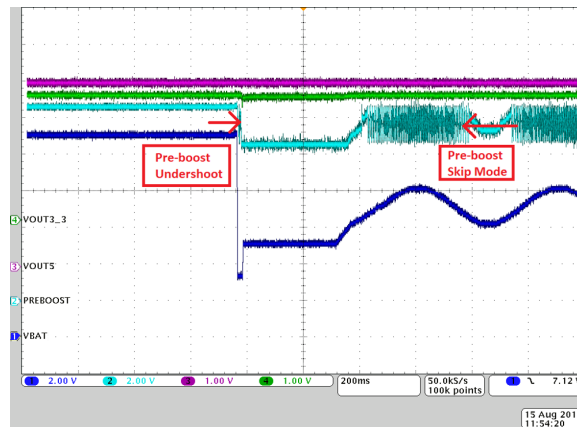

3.2.2.2 Tell-Tale Indicator Testing

图 28 highlights the tell-tale indicators across the board. There are three kinds of tell-tales tested: safety-related tell-tale, simulated gear-shift tell-tale, and general tell-tale.

图 28. TIDA-01628 Tell-Tale Indicators



表 4 outlines each tell-tale function and the meaning of its indicators.

表 4. TIDA-01628 Tell-tale Indicators Function

TELL-TALE INDICATOR	FUNCTION
Safety	Notifies driver if the battery has shorted or disconnected
Simulated Gear	Specifies to the driver which gear the car is currently in
General	General notifications to the driver such as seat belt, fuel tank low, check engine, and so forth

The most important indicator is the safety-related tell-tale. This reference design easily demonstrates this function with two LED indicators. If the battery LED circuit is disconnected, the Open Fault LED will turn on to signify that the fault was triggered. If a short occurs in the battery LED circuit, the short LED turns on to indicate the shorted LED error. 图 29 shows the board behavior when the battery is shorted.

图 29. TIDA-01628 Tell-Tale Indicator - Shorted Battery



3.2.2.3 Backlight and Ambient Light Sensing Testing

Ambient light sensing and adjustable brightness settings for backlight are becoming more common in clusters since the backlight is now left on even during daylight hours. The TPS61193-Q1 uses a 10-kHz fixed-frequency PWM signal with a programmable duty cycle generated by the MSP430 to provide global brightness control functionality. 表 5 shows the relationship between brightness level and the MSP430 PWM duty cycle. See [Understanding and Interpreting Lux Values](#) for further information on brightness settings.

表 5. TIDA-01628 Brightness Setting

ILLUMINANCE (LUX)	LIGHTING STEP SET
1 - 10	1
11 - 50	2
51 - 200	3
201 - 400	4
401 - 1,000	5
1,001 - 5,000	6
5,001-10,000	7

3.2.2.4 Sound Pressure Level (SPL) Testing

The *Sound Pressure Level* (SPL) for the TPA6211A1-Q1 audio amplifier was tested with a *Unique Sound* model US-4008J speaker, with a speaker rating of 103 dB at 1.0 W. A 1.3-kHz test signal was applied to the input of [图 18](#). The results are in [表 6](#).

表 6. TPA6211A1-Q1 Output Power and Speaker SPL

INPUT (Vrms)	OUTPUT POWER (W)	SPL (dB)	THD (%)
1.06	0.25	99.5	0.08
1.5	0.5	101.2	0.064
1.84	0.75	102.8	0.054
2.13	1.00	104	0.057
2.39	1.25	105.3	0.73
2.71	1.5	106.2	5.12

Note: Data taken 10 cm from speaker playing 1.3 KHz sine wave while mounted on a baffle. Analog input signal from AP2700. Noise floor level was 46.0 dB.

4 Design Files

4.1 Schematics

To download the schematics, see the design files at [TIDA-01628](#).

4.2 Bill of Materials

To download the bill of materials (BOM), see the design files at [TIDA-01628](#).

4.3 PCB Layout Recommendations

The TIDA-01628 PCB is a four-layer board:

- The top layer is for the LED traces.
- The second layer is a GND plane.
- The third layer is the power layer.
- The bottom layer has the majority of components.

For most of the components on this design, the recommendation from the datasheet is followed. The top layer was mostly used for the LED traces while the bottom layer was used to route the majority of the components. Otherwise unused areas are filled with copper and connected to ground for thermal performance. To keep traces from coupling, the second layer is a full ground plane. Lastly, the third layer was used to route the power rails. The following figures show the major components used in this design. Follow the layout recommendations for these components outlined in the data sheets of each product.

图 30. TIDA-01628 Top Layer



图 31. TIDA-01628 GND Layer



图 32. TIDA-01628 Power Layer

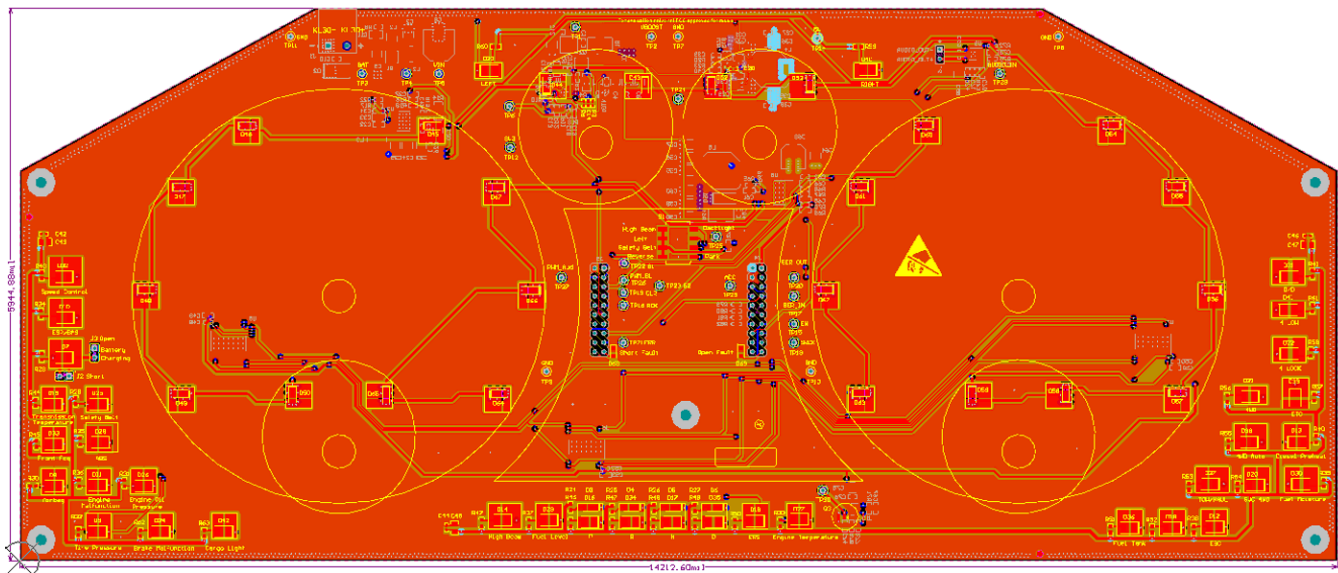

图 33. TIDA-01628 Bottom Layer

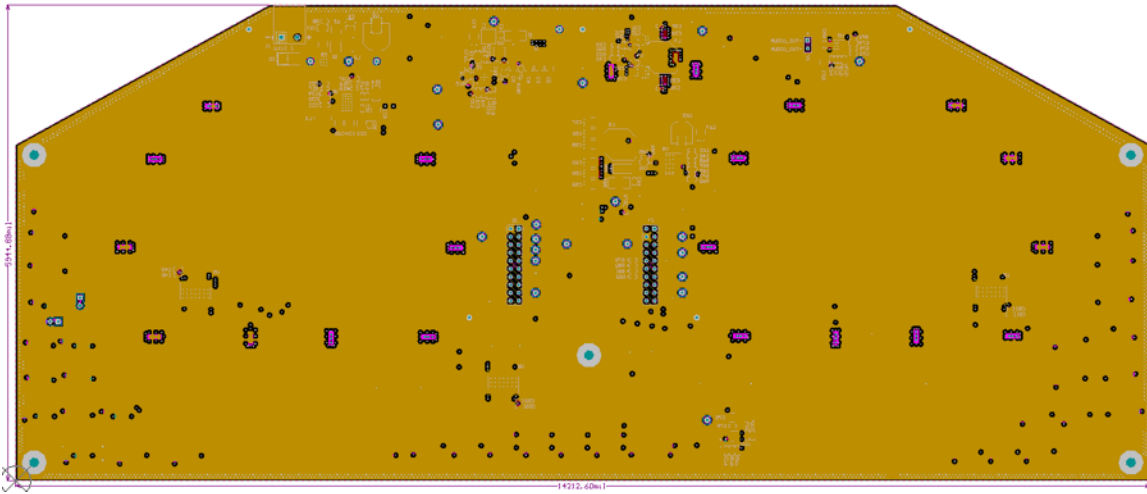

4.3.1 Layout Prints

To download the layer plots, see the design files at [TIDA-01628](https://www.ti.com/lit/zip/TIDA-01628).

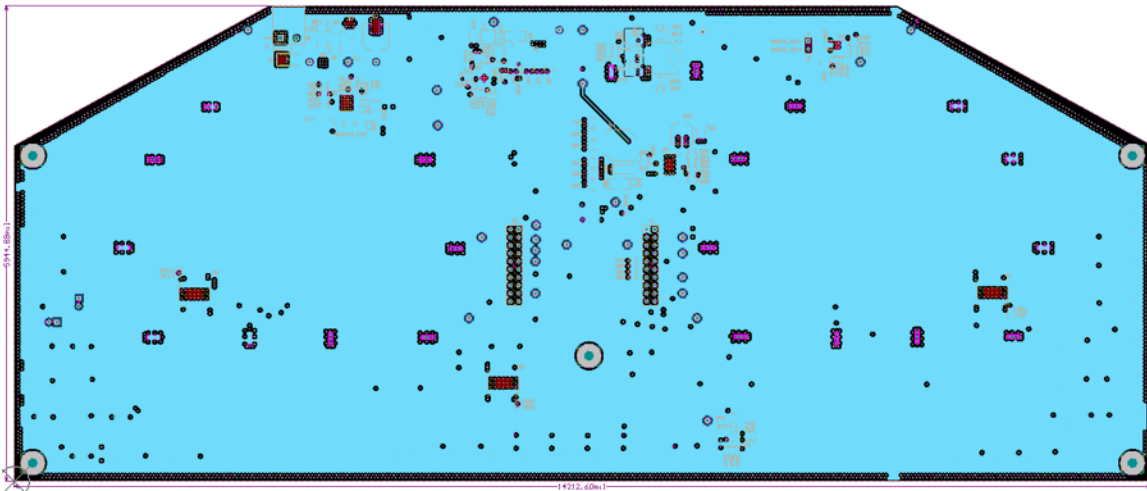
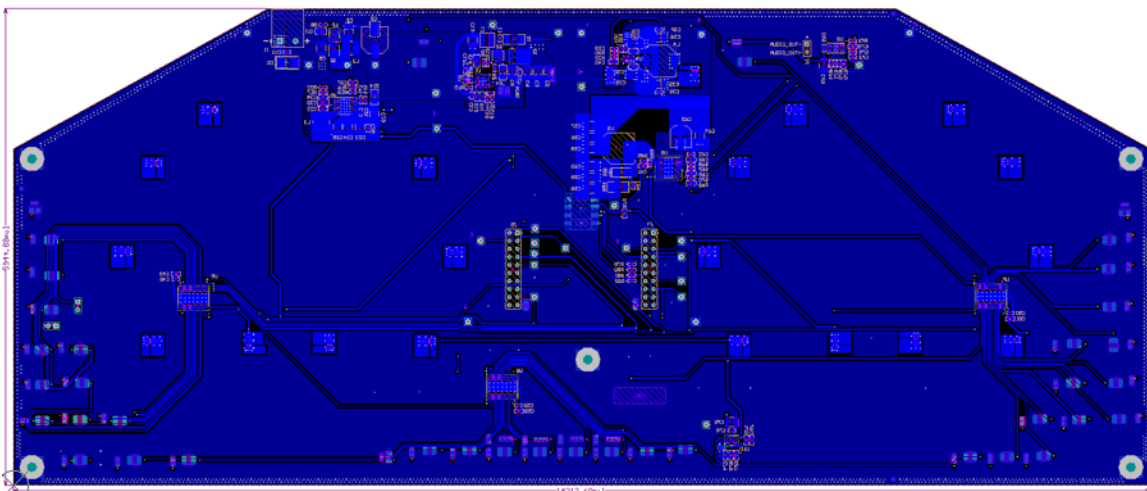
4.3.2 LM74700-Q1 Reverse Battery Protection Layout

图 34. Reverse Polarity Protection Design

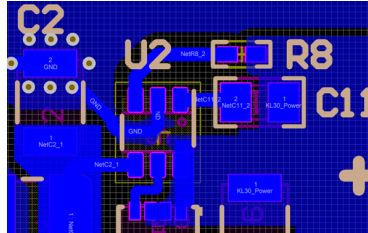

4.3.3 Power Supply Layouts

This section contains the PCB layout of the LM5150-Q1 pre-boost, LMR33630-Q1 5-V buck converter, LM43602-Q1 3.3-V buck converter, and the TPS61193-Q1 backlight supply.

4.3.3.1 LM5150-Q1 Pre-Boost Layout

图 35. Pre-Boost Circuit Design

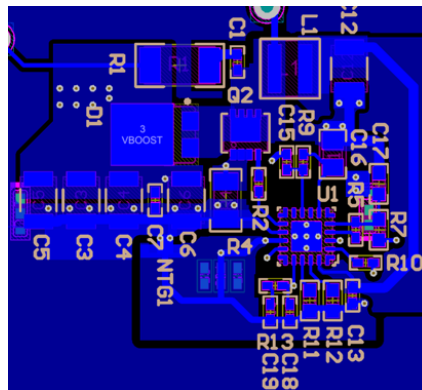

4.3.3.2 LMR33630-Q1 5-V Buck Converter Layout

图 36. 5-V Buck Design

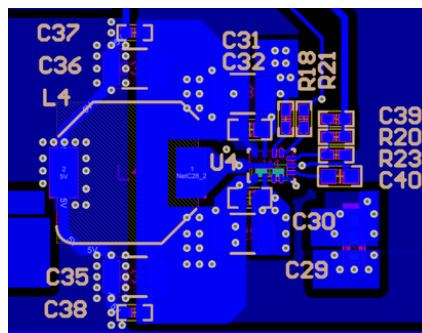

4.3.3.3 LM43602-Q1 3.3 V Buck Converter Layout

图 37. 3.3-V Buck Design

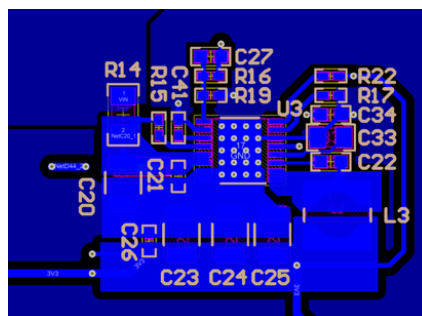

4.3.3.4 TPS61193-Q1 Backlight Power Supply

图 38 shows the TPS61193-Q1 PCB layout.

图 38. TPS61193-Q1 PCB Layout

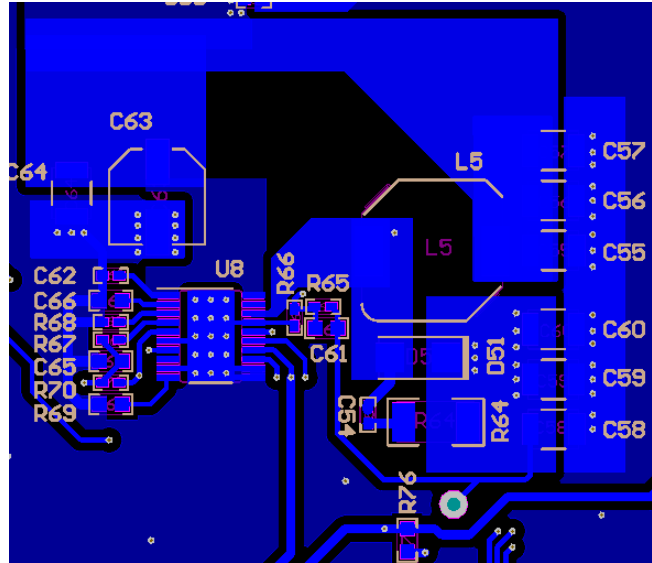

4.3.4 Ambient Light Sensor Layout

图 39. Ambient Light Sensing Design

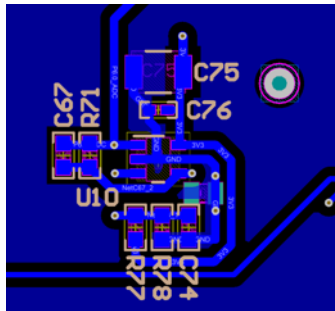

4.3.5 TPA6211A1-Q1 Chime Warning Audio Amplifier Layout

图 40. Audio Chime Warning Design

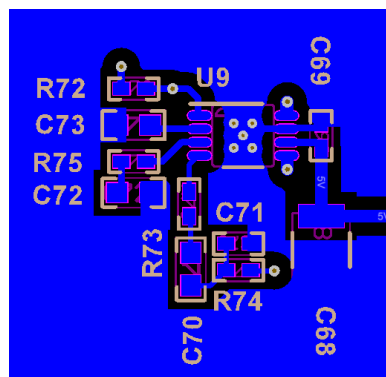

4.4 Altium Project

To download the Altium project files, see the design files at [TIDA-01628](#).

4.5 Gerber Files

To download the Gerber files, see the design files at [TIDA-01628](#)..

4.6 Assembly Drawings

To download the assembly drawings, see the design files at [TIDA-01628](#).

5 Software Files

To download the software files, see the files at [TIDA-01628](#).

6 References

1. Texas Instruments, [LM74700-Q1 Zero \$I_Q\$ Reverse Polarity Protection Smart Diode Controller Data Sheet](#)
2. Texas Instruments, [LM5150-Q1 Wide VIN Automotive Low \$I_Q\$ Boost Controller Data Sheet](#)
3. Texas Instruments, [LMR33630 SIMPLE SWITCHER® 3.8-V to 36-V, 3-A Synchronous Step-Down Voltage Converter Data Sheet](#)
4. Texas Instruments, [LM43602-Q1 3.5-V to 36-V, 2-A Synchronous Step-Down Voltage Converter Data Sheet](#)
5. Texas Instruments, [TLC6C5816-Q1 Power Logic 16-Bit Shift Register LED Driver With Diagnostics Data Sheet](#)
6. Texas Instruments, [TPS61193-Q1 Low-EMI Automotive LED Driver With Three 100-mA Channels Data Sheet](#)
7. Texas Instruments, [TPA6211A1-Q1 3.1-W Mono Fully Differential Audio Power Amplifier Data Sheet](#)
8. Texas Instruments, [OPAx320-Q1 Precision, 20-MHz, 0.9-pA, Low-Noise, RRIO, CMOS Operational Amplifier Data Sheet](#)
9. 1 MHz, Single-Supply, Photodiode Amplifier Reference Design [TIPD176](#)

6.1 商标

E2E, LaunchPad, MSP430, PowerPAD, Code Composer Studio are trademarks of Texas Instruments. All other trademarks are the property of their respective owners.

7 About the Author

PHIL CHENG is a Field Application Engineer at Texas Instruments. He received his bachelor of science in electrical engineering from Tongji University in Shanghai. He focuses on automotive analog applications and solutions.

修订历史记录

注：之前版本的页码可能与当前版本有所不同。

Changes from Original (November 2018) to A Revision	Page
• 已添加 the speaker rating of the <i>Unique Sound</i> speaker.....	30
• 已更改 the test signal value that is applied to the input of the <i>Chime Audio Amplifier Schematic</i>	30
• 已更改 information in the <i>TPA6211A1-Q1 Output Power and Speaker SPL</i> table.....	30

重要声明和免责声明

TI“按原样”提供技术和可靠性数据（包括数据表）、设计资源（包括参考设计）、应用或其他设计建议、网络工具、安全信息和其他资源，不保证没有瑕疵且不做任何明示或暗示的担保，包括但不限于对适销性、某特定用途方面的适用性或不侵犯任何第三方知识产权的暗示担保。

这些资源可供使用 TI 产品进行设计的熟练开发人员使用。您将自行承担以下全部责任：(1) 针对您的应用选择合适的 TI 产品，(2) 设计、验证并测试您的应用，(3) 确保您的应用满足相应标准以及任何其他功能安全、信息安全、监管或其他要求。

这些资源如有变更，恕不另行通知。TI 授权您仅可将这些资源用于研发本资源所述的 TI 产品的应用。严禁对这些资源进行其他复制或展示。您无权使用任何其他 TI 知识产权或任何第三方知识产权。您应全额赔偿因在这些资源的使用中对 TI 及其代表造成的任何索赔、损害、成本、损失和债务，TI 对此概不负责。

TI 提供的产品受 [TI 的销售条款](#) 或 [ti.com](#) 上其他适用条款/TI 产品随附的其他适用条款的约束。TI 提供这些资源并不会扩展或以其他方式更改 TI 针对 TI 产品发布的适用的担保或担保免责声明。

TI 反对并拒绝您可能提出的任何其他或不同的条款。

邮寄地址：Texas Instruments, Post Office Box 655303, Dallas, Texas 75265

Copyright © 2022，德州仪器 (TI) 公司