

# TI Designs: TIDA-010040 警报音发生器参考设计



## 说明

该参考设计的开发目的是帮助客户提升医用警报系统性能，使其达到国际电工委员会 (IEC) 规定的 60601-1-8 标准。该系统为客户提供了产生音频警报音的方法。这些医用警报的设计配合使用了完全符合 IEC 60601-1 标准的医疗器械终端产品系统，可以用于医用患者监护，也可用于测量人体参数（例如心率和呼吸）的 ECG 系统。警报的关键时序参数可通过固件进行编程。所有参数（包括脉宽、脉率、内部频率、脉冲上升时间、音量控制以及优先级）都可以使用固件进行控制。

## 资源

|                              |       |
|------------------------------|-------|
| <a href="#">TIDA-010040</a>  | 设计文件夹 |
| <a href="#">MSP430FR2311</a> | 产品文件夹 |
| <a href="#">TPA2005D1</a>    | 产品文件夹 |
| <a href="#">TS5A23157</a>    | 产品文件夹 |

## 特性

- 利用可编程时序和频率提供产生音频警报音的机制
- 利用软件可调节的上升/下降时间、脉冲持续时间、脉冲间隔以及突发间隔输出优先级低、中、高的警报
- 音量控制
- 输出 8 种不同的警报音调
- 重合检测器确认扬声器是否输出正确的声音

## 应用

- 患者监护
- CPAP 呼吸机
- 心电图 (ECG)

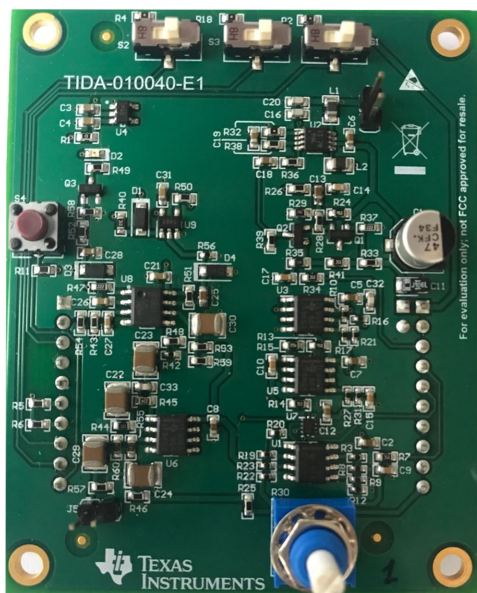
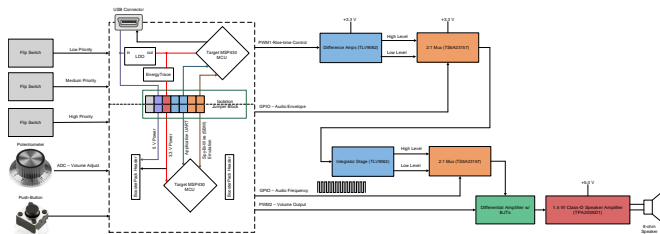
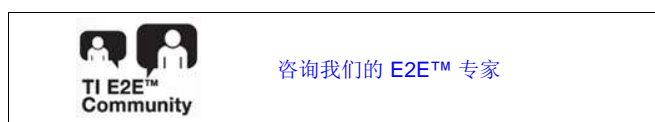

该 TI 参考设计末尾的重要声明表述了授权使用、知识产权问题和其他重要的免责声明和信息。

## 1 System Description

This Alarm Tone Generator Reference Design uses six general purpose operational amplifiers (op amps) (3xTLV9062), a 2-channel, 2:1 multiplexer (MUX), (TTS5A23157), a 1.4-W, class-D speaker amplifier (TPA2005D1), and an MSP430 LaunchPad™, (MSPEXP430FR2311). The MSP430 on the LaunchPad controls the timing of the audio pulses as well as audio frequencies. The op amps are used to shape the audio pulses to have the appropriate rise and fall times. The MUXs are used to modulate the audio frequency with the analog envelope. The analog envelope is generated by a combination of the MSP430FR2311 and analog circuitry. An 8-ohm speaker is driven by the audio amplifier TPA2005D1.

A coincidence detector circuit includes a condenser microphone that is kept in close proximity to the speaker to detect its sound. If the envelope of the microphone sound is the same as the sound sent from the speaker, a flag is raised to indicate a valid sound. An alarm is triggered when the parameters are outside of the normal limits, as part of the IEC 60601-1 compliant annunciation personnel alert design.

### 1.1 Key System Specifications

表 1. Key System Specifications

| PARAMETER      | SPECIFICATIONS   | DETAILS   |
|----------------|--|---|
| Input power    | 5-V micro-USB port on LaunchPad                          | Micro-USB will provide 5 V to LaunchPad, which will be used directly by audio amplifier. LaunchPad has LDO which generates a 3.3-V rail, which will be used for the rest of the parts |
| Volume control | Adjusted by a potentiometer on PCB going to an ADC input | Adjust system volume  |
| Priority level | Selected by flipping one of three switches on PCB        | Select high, medium, or low priority  |
| Melody         | Changed by pressing switch S4 on TIDA-010040             | Select different tones  |

## 2 System Overview

### 2.1 Block Diagram

图 1. TIDA-010040 Block Diagram



图 1 shows the high-level block diagram for the TIDA-010040. This design is a PCB booster pack that interfaces with the MSP430FR2311 LaunchPad through headers. The MSP430 on the LaunchPad will toggle a GPIO output at specific times to control when the audio pulses will start. This signal is labeled as *GPIO – Audio Envelope* in the block diagram. This signal will range from 0 V to 3.3 V, but when it is used as the select input of the MUX, the output of the MUX will have different high and low values. The output of this MUX will go into an op amp integrator, which is where the slope for the rise and fall time is created. The high and low values mentioned previously (signals are called *High Level* and *Low Level* in the block diagram) will determine the slope of the resulting envelope, thus changing the rise and fall time. This high and low level will be created by two difference amplifiers, which are given a DC voltage signal coming from a PWM output of the LaunchPad that is put through an RC filter to determine the average. This PWM signal is labeled *PWM1 – Rise time Control* in the diagram. The duty cycle of this signal will change the rise time and can be changed by adjusting a variable in the code. Based on the hardware architecture, the rise time will be equal to the fall time. By changing the PWM, labeled *PWM1*, value in the software code, it is possible to change the rise and the fall times.

The input to the second MUX is the top and bottom halves of the audio envelope. The select signal to this MUX (labeled *GPIO – Audio Frequency*) will modulate the audio envelope with the appropriate frequency to generate the desired note. The specific frequencies are generated in the software by changing the counter value of one of the counting registers used.

The resulting signal is an audio envelope with a rise and fall time, with the highest value being 3.3 V and lowest being 0 V. This signal will go into a difference amplifier, implemented with two PNP BJTs, to lower the voltage level (volume) of the audio signal. The volume will be adjusted by a PWM signal, *PWM2 – Volume Output* that is averaged by an RC filter. The final signal will go to the input of a class-D audio amplifier (TPA2005D1) that is configured to have a gain of 2 V/V. This amplifier will drive an 8-ohm speaker that is mounted onto the PCB.

A coincidence detector circuit includes a condenser microphone that is kept in close proximity to the speaker to detect its sound. If the envelope of the microphone sound is the same as the sound sent from the speaker, a flag is raised to indicate a valid sound.

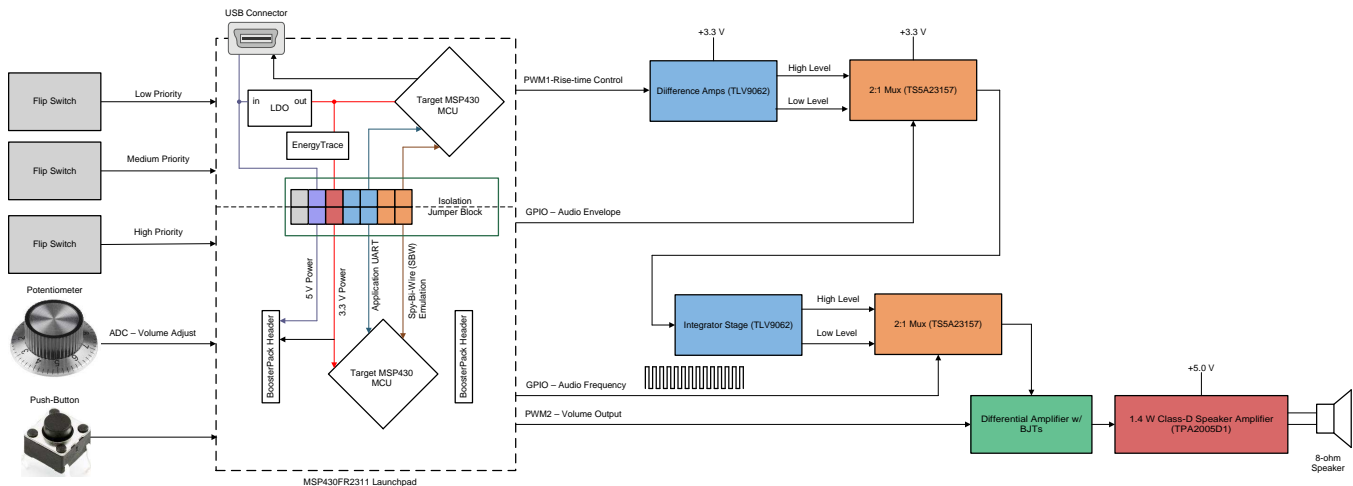
## 2.2 Design Considerations

See 3 节 for timing requirements.

## 2.3 Highlighted Products

### 2.3.1 MSP430FR2311

The MSP430FR231x FRAM microcontrollers (MCUs) are part of the MSP430 MCU value line sensing family. The devices integrate a configurable low-leakage transimpedance amplifier (TIA) and a general-purpose operational amplifier (op amp). The MCUs feature a powerful 16-bit RISC CPU, 16-bit registers, and a constant generator that contribute to maximum code efficiency. The digitally controlled oscillator (DCO) also allows the device to wake up from low-power modes to active mode typically in less than 10  $\mu$ s.

### 2.3.2 2 TLV9062 – Rail-to-Rail Op Amp

The TLV9062 (dual) is a dual, low-voltage (1.8 V to 5.5 V) operational amplifier with rail-to-rail input- and output-swing capabilities. These devices are highly cost-effective solutions for applications where low-voltage operation, a small footprint, and high capacitive load drive are required. Although the capacitive load drive of the TLV9062 is 100 pF, the resistive open-loop output impedance makes stabilizing with higher capacitive loads simpler. These op amps are designed specifically for low-voltage operation (1.8 V to 5.5 V) with performance specifications similar to the OPAx316 and TLVx316 devices.

### 2.3.3 TS5A23157 – 2:1 Mux

The TS5A23157 device is a dual, single-pole double- Low ON-state resistance (10  $\Omega$ ) control inputs are 5-V tolerant throw (SPDT) analog switch designed to operate from 1.65 V to 5.5 V.

### 2.3.4 TPA2005D1 – Class-D Audio Amplifier

The TPA2005D1 is a 1.4-W high efficiency filter-free 1• 1.4 W Into 8  $\Omega$  From a 5 V Supply at THD = 10% (Typ) class-D audio power amplifier in a MicroStar Junior™ BGA, QFN, or MSOP package that requires only three external components .

## 2.4 System Design Theory

This section explains the design theory (and equations, if required) for each of the devices used in the design.



2.4.1 1 Rise-Time Control

图 2. Difference Amplifier

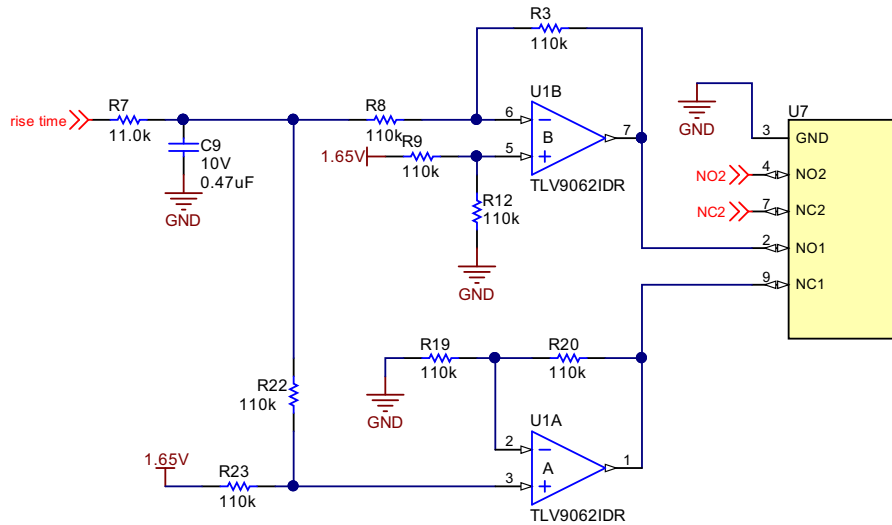

The integrator, U5A, will have a square wave at the input and will insert a slope at the square wave's rising and falling edge. The op amp is also inverting, so a rising edge at the input will result in a negative slope at the output. The rise time can be calculated using the following equations.

The current through the capacitor C10 must equal the current through resistor R14 because no current can flow through the input to the op amp.  $V_{in}$  refers to the COM1 output voltage from the MUX.

$$i_c = \frac{V_{in} - 1.65 \text{ V}}{R14} \tag{1}$$

$$i_c = C10 \times \left( \frac{dv_c}{dt} \right) \tag{2}$$

Set the current equations equal to each other.

$$\frac{V_{in} - 1.65 \text{ V}}{R14} = C10 \times \left( \frac{dv_c}{dt} \right) \tag{3}$$

The  $dv/dt$  expression in refers to the change in the capacitor's voltage over a certain amount of time. It is known that the capacitor will always have 1.65 V on one terminal, and the other terminal will charge up to 3.3 V and discharge to 0 V. The amount of time that it takes to charge and discharge to these values will be the rise and fall time of the resulting audio signal. Because of this, we can set  $dv$  equal to 3.3 V and  $dt$  equal to the rise time ( $t_{rise}$ ). The rise time will equal the fall time.

$$\frac{V_{in} - 1.65 \text{ V}}{R14} = C10 \times \left( \frac{3.3 \text{ V}}{t_{rise}} \right) \tag{4}$$

The fastest rise time corresponds to  $V_{in} = 3.3 \text{ V}$ .

Substituting  $V_{in} = 3.3 \text{ V}$  in 公式 4 will result in:

$$t_{rise} = 2 \times R14 \times C10 \tag{5}$$

The input voltage,  $V_{in}$ , is determined by the output of the difference amplifier stage. This stage will output  $1.65 \text{ V} - x$ , and  $1.65 \text{ V} + x$ , where  $x$  is the average of the PWM signal labeled *rise time* in 图 2.

Op amp U1B makes  $1.65 \text{ V} + x$  at point NO1. Op amp U1A creates  $1.65 \text{ V} + x$  at point NC1. This PWM signal creating signal  $x$  is allowed in software to have a maximum average value of 1.65 V. This corresponds to a maximum duty cycle of 50%.

表 2. Voltage

| VOLTAGE ON C9 | VOLTAGE ON PIN 2 U7 | VOLTAGE ON PIN 9 U7 |   |
|---------------|---------------------|---------------------|---|
| x             | 1.65 - x            | 1.65 + x            | Rise time rate                                  |
| 0 V           | 1.65 V              | 1.65 V              | Slowest as zero charge and discharge current    |
| 1.65 V        | 0 V                 | 3.3 V               | Fastest as highest charge and discharge current |

图 3. Envelope Generation



图 4. Envelope



The square wave from the microcontroller is passed through an integrator formed by U5A. This shapes the rising and falling edges of the waveform to create the waveform at U5A pin 1 shown in 图 3. R15 and R13 level shift this waveform by 1.65 V creating waveform at U3A pin 1. U3B forms a unity gain differential amplifier and creates an inverted form of the waveform on U3B pin 7 shown in 图 4.

The two signals NC2 and NO2 are passed into the analog multiplexer U7 TS5A23157. An *Audio Frequency* signal from the microcontroller is used to switch either U3A pin 1 or U3B pin 7 to the output creating the complex chopped waveform shown in 图 4.

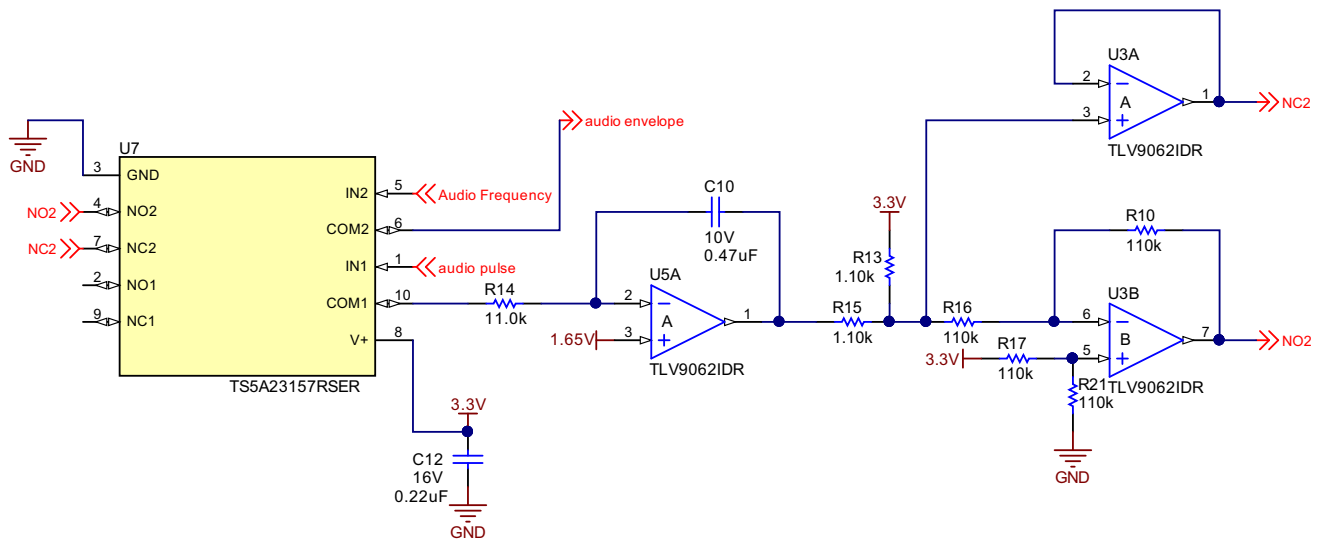
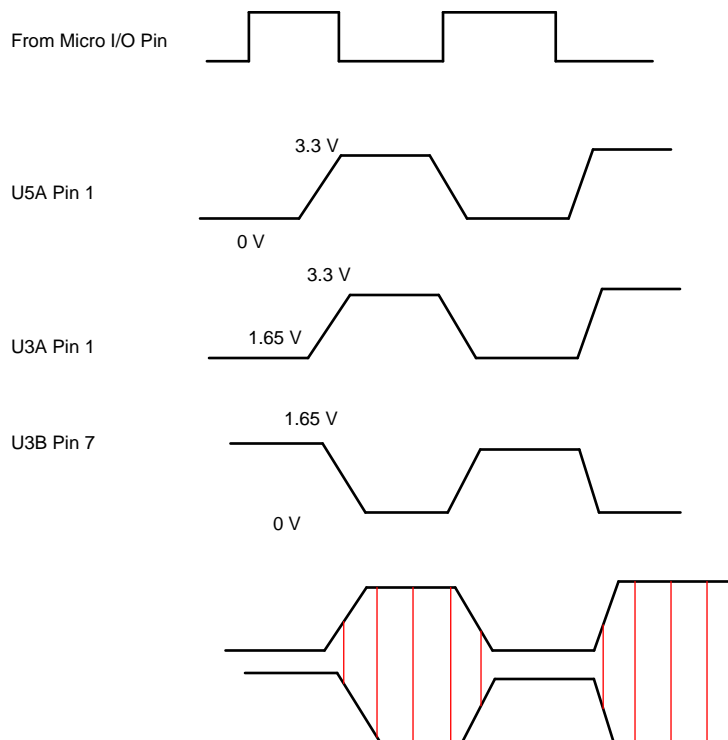
## 2.5 Volume Control

图 5. Gain Control

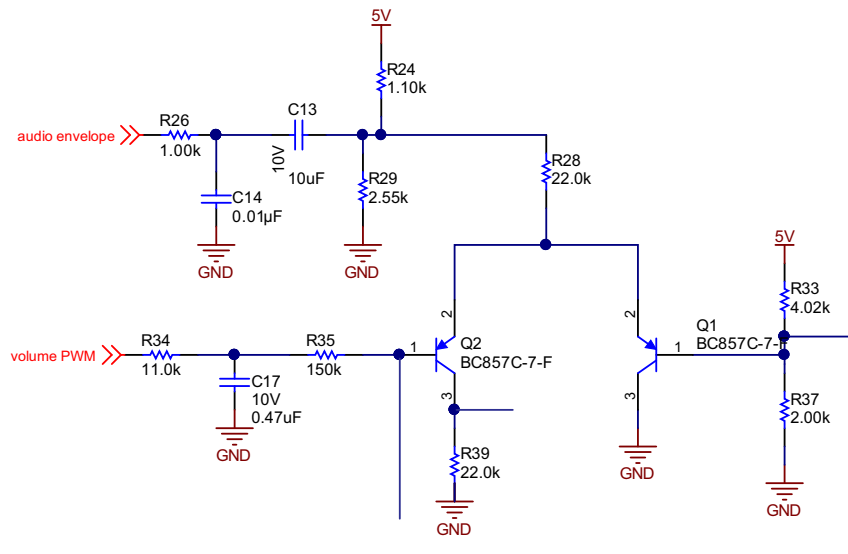

The circuit has two transistors set up as a differential amplifier. The circuit controls the DC control voltage applied between the bases of the two transistors Q1 and Q2.

$I_{in}$  is the current flowing in resistance R28 which is connected to the emitter leads of the 2 transistors.  $I_o$  is current flowing in R39. If  $V_{BQ1} - V_{BQ2} > 60\text{ mV}$ , all current  $I_{in}$  flows to  $I_o$ . If  $V_{BQ2} - V_{BQ1} > 60\text{ mV}$   $I_o = 0$ . For voltage differences, less than 60 mV of the current is shared between the transistors. This action works for AC and DC signals by controlling voltage across the base of the devices where we can change gain.

The average value of the PWM controls the voltage across the bases of the transistors. For example, PWM is zero duty cycle:  $V_{pwm} = 0\text{ V}$ . Bias  $V_{BQ1}$  to 1.65 V by means of a voltage divider. A voltage divider set up by R33 and R37 make  $V_{BQ2} = 1.55\text{ V}$ .  $(1.65 / (R41 + R35) \times R35)$  This gives more than 60 mV between the bases of transistors. Q1 is now turned off and Q2 is an operating current source.

$$I_n = \left( \frac{3.5 - 2.3}{22k} \right) = 55\text{ }\mu\text{a} \tag{6}$$

$$I_o = I_n \tag{7}$$

$$V_o = I_o \times R39 = 55\text{ }\mu\text{a} \times 22k \tag{8}$$

$$V_o = 1.2\text{ V} \tag{9}$$

Assume a sine wave of 1.5 Vpp or 0.75 v Vpk is coupled at  $V_{in}$ . At the junction of R24 and R29, there is a sine wave riding on a bias of 3.5 V. The peak voltage is now 4.25 V and lowest is 2.75 V.

$I_{in} = (V_{\text{Junction R24, R29}} - V_{\text{emitter}}) / R28$  is now a sine wave current on a dc bias.

$I_{in} = I_o$  and  $V_{R33} = I_o \times R_{33}$ .

$I_{in} P_k = (4.25-2.3)/22k V_{opk} = 2 V$ . The output waveform is a sine which goes from 1.2 V to 2 V and down to 0.5 V.

With PWM = 0, the system has a gain of 1.

Another example: PWM is 100% duty cycle.  $V_{bQ2}$  has a 100 mv greater than  $V_{bQ1}$ . Q2 is completely turned off. Q is now a current source and all of the current flows through Q1A to ground. Therefore no output appears across R39. This is a gain of zero.

Another example: All duty cycles from 0% to 100% shall have gains from 1 to 0. The DC bias at the output also goes from 1.2 V towards zero.

Potentiometer R30 controls the volume. By changing the potentiometer, a variable DC voltage is fed to an ADC pin of the microcontroller. The software sets up a PWM used to control the analog transistor circuit.

## 2.6 4 Class-D Audio Amplifier

图 6. Class-D Audio Amplifier

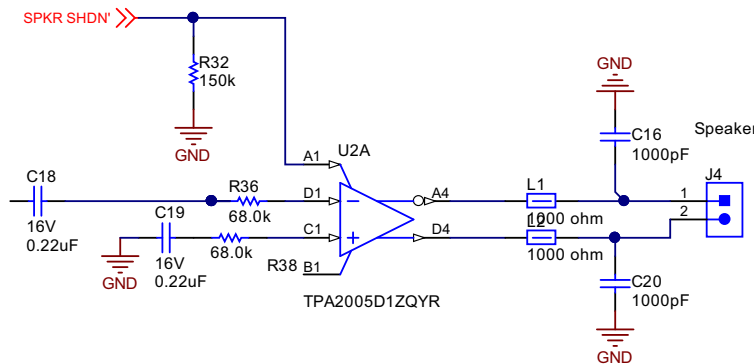

The TPA2005D1 is a class-D audio amplifier working on a +5-V supply. It is used in a filter-free mode and can drive an 8-ohm speaker to produce the desired tone. The IC has a differential input and is set up as a single-ended amplifier. The gain is set by R35 and R38. L1 and L2 are ferrite beads used for EMI suppression.

## 2.7 Coincidence Detection Circuit

图 7. Coincidence 3



图 8. Coincidence 4



Medical alarms are often used in patient-monitoring systems. In such systems, critical parameters, such as breathing or heartbeat, are typically measured and if a critical signal reading goes out of the normal limits, the alarm is activated, alerting hospital personnel. However, in the event of a faulty speaker or broken wiring, sound might not be emitted from the alarm. In order to help avoid such an event, the sound made by the board can be monitored such that if the sound fails, a fault flag can be given to the MCU.

The coincidence detector circuit uses a condenser microphone placed in close proximity to the speaker to monitor the sound. If the envelope of the sound received by the microphone and the sound transmitted by the speaker are the same and coincide in time with each other, then the sound is acceptable. If the two envelopes are not coinciding, then a fault in the sound has occurred.

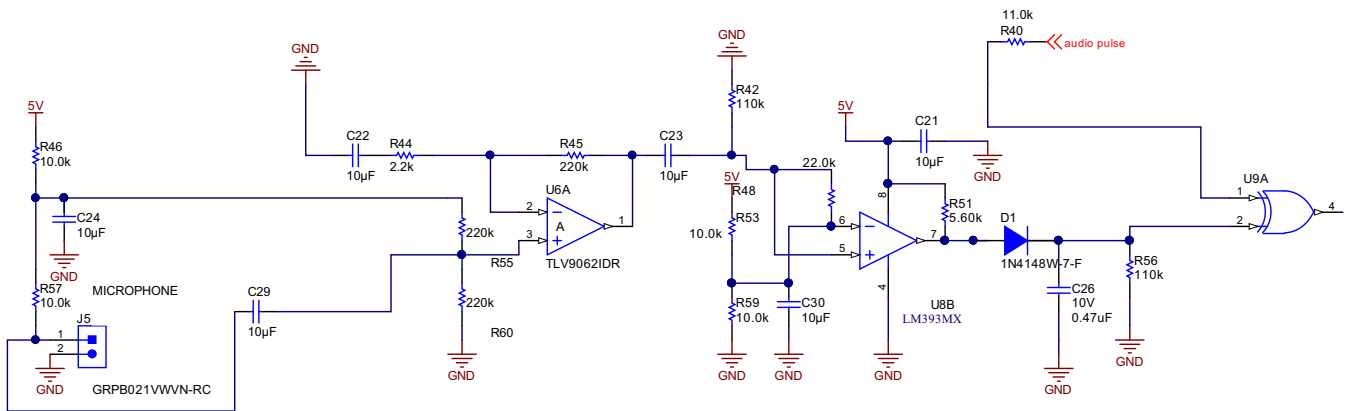
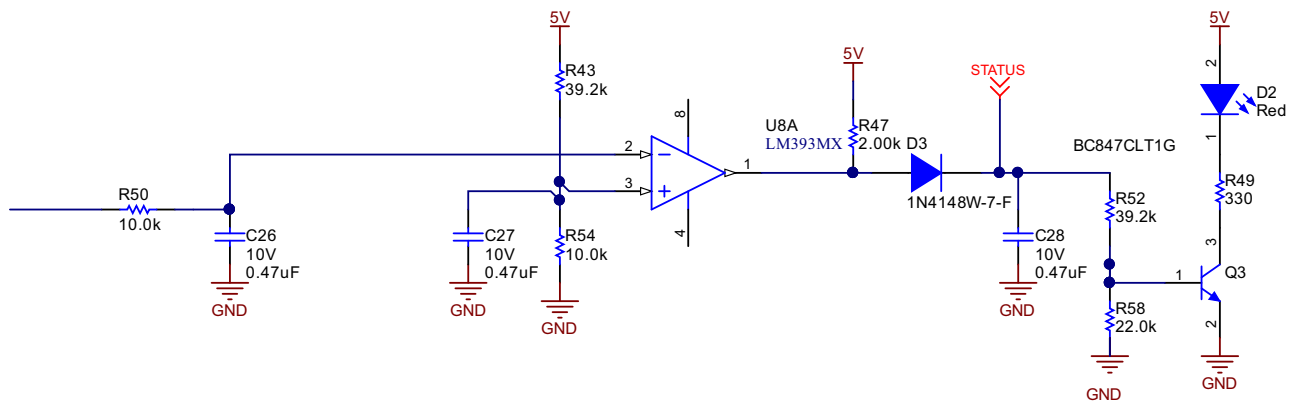
A condenser microphone is placed in connector J5, and its signals are amplified using op amp U6A. Comparator U8B forms an analog signal to the TTL converter. This converts the analog variations received on the microphone to pulses. D1 and C26 form an envelope detector that make a pulse with a width equal to the period for which signals were received at the microphone.

The signal audio pulse is made by the microcontroller to make a single burst of tone. XOR gate U9A is used to compare the envelope of the microphone signal received and the audio pulse generating the sound driven into the speaker. If the microphone is close to the speaker and is receiving the bursts, both signals are the same. The output of the gate is low. If the microphone does not receive any signal from the speaker, the output of the envelope detector is low. The XOR gate then delivers 2, 3, or 5 pulses depending on the mode.

U8A receives the average output of the XOR gate. When the microphone is close to the speaker and it receives sound, the average value of the XOR gate is low. Comparator U8A output is high and turns on LED D2 permanently. When the microphone is positioned away from the speaker or the speaker is not making sound, the comparator output makes pulses that drive pulses into LED D2.

### 3 Hardware, Software, Testing Requirements, and Test Results

#### 3.1 Required Hardware and Software

##### 3.1.1 Hardware

This section describes the requirements on the waveforms that constitute medical alarms. The tones are described as groups of pulses, with each pulse containing multiple cycles of a frequency ( $F_p$ ). 图 9 describes the characteristics of each pulse. Each pulse has a certain rise time ( $t_r$ ), width ( $t_d$ ), and fall time ( $t_f$ ). A spacing ( $t_s$ ) exists between any two pulses. A group of pulses forms a burst. The time between 2 bursts is ( $t_b$ ).

图 9. Burst

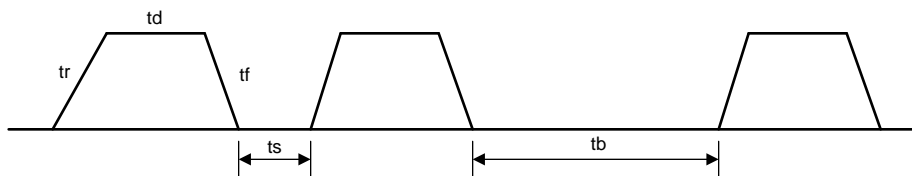

A typical alarm may result in a beeping sound. This beeping is two bursts of two pulses. Each pulse is made of many cycles of a pulse frequency  $F_p$ .

表 3 shows the timing requirement of the waveforms.

表 3. Timing Requirements of the Waveforms

| CHARACTERISTIC                                   | VALUE            |
|--|------------------|
| Pulse frequency ( $F_o$ )                        | 150 Hz - 1000 Hz |
| Number of harmonics in range of 300 Hz - 1000 Hz | 4                |
| Pulse duration ( $t_d$ ) medium/low              | 125 ms - 250 ms  |
| Pulse duration ( $t_d$ ) high                    | 75 ms - 200 ms   |
| Rise time ( $t_r$ )                              | 10% of $t_d$     |

There are typically three kinds priority of alarm signals.

表 4. Number of Pulses in a Burst for Each Type of Alarm Priority

| PRIORITY | NUMBER OF PULSES IN A BURST   |
|----------|---|
| High     | 10 (2 groups of 5 pulses separated by a time from 0.35 - 1.3 seconds) |
| Medium   | 3   |
| Low      | 2   |

图 10. Priority

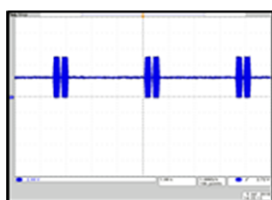

LOW PRIORITY

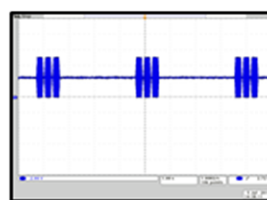

MEDIUM PRIORITY

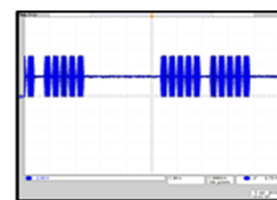

HIGH PRIORITY



**表 5. Pulse Spacing**

|            | HIGH PRIORITY | MEDIUM PRIORITY | LOW PRIORITY |
|------------|---------------|-----------------|--------------|
| 1 and 2    | x             | y               | y            |
| 2 and 3    | x             | y               |              |
| 3 and 4    | 2 × (x + t)   |                 |              |
| 4 and 5    | x             |                 |              |
| 5 and 6    | 0.35s - 1.3s  |                 |              |
| 6 and 7    | x             |                 |              |
| 7 and 8    | x             |                 |              |
| 8 and 9    | 2 × (x + t)   |                 |              |
| 9 and 10   | x             |                 |              |
| Interburst | 2.5s - 15s    | 2.5s - 30s      | >15s         |

$$X = 50 \text{ ms} - 125 \text{ ms} \quad (10)$$

$$T = td \quad (11)$$

$$Y = 125 \text{ ms} - 250 \text{ ms} \quad (12)$$

Switch S1, S2, and S3 can be used to select a low, medium, or high priority alarm.

Mode switch S4 selects one out of eight possible melodies for medium and high priority alarms. Each music note in 表 5 corresponds to a frequency from 表 6.

**表 6. Music Note Frequencies**

| MUSIC NOTE | FREQUENCY |
|------------|-----------|
| c          | 261       |
| C          | 523       |
| e          | 330       |
| g          | 392       |
| f#         | 370       |
| a          | 440       |
| f          | 349       |
| b          | 494       |
| d          | 294       |

**表 7. Music Notes by Mode**

| MODE                 | HIGH     | MEDIUM | LOW |
|----------------------|----------|--------|-----|
| General              | ccc-cc   | ccc    |     |
| Cardiac              | ceg-Gc   | ceg    |     |
| Artificial Perfusion | cf#c-cf# | cf#c   |     |
| Ventilation          | caf-af   | caf    |     |
| Oxygen               | Cba-gf   | Cba    |     |
| Temperature          | cde-fg   | cde    |     |
| Drug                 | Cdg-Cd   | Cdg    |     |
| Equipment            | Ccc-Cc   | Ccc    |     |
| Any                  |          |        | ec  |

### 3.1.2 Required Hardware

LaunchPads are MCU development kits from TI. A variety of these kits are available to address various applications. The MSP-EXP430FR2311 LaunchPad is an inexpensive and simple development kit for the MSP430FR2311 MCU. This LaunchPad offers an easy way to develop the MSP430 MCU with onboard emulation for programming and debugging as well as buttons and light-emitting-diodes (LEDs) for user interface. 图 11 shows the FR2311 LaunchPad.

The two 10-pin male connectors are accessible from the bottom of the board as female connectors.

图 11. MSP





图 14 shows the PCB connections for the J1, J2, and J3 headers that will connect the signals on the LaunchPad to the PCB.

图 14. PCB Connections

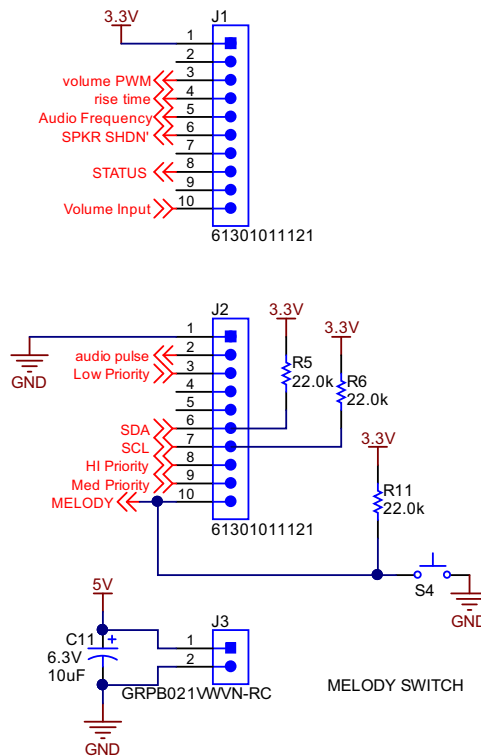

### 3.1.3 Software

The software for the MSP430 is responsible for all of the timing parameters associated with the audio bursts. There are three switches on the PCB that determine the priority level (low, medium, or high). Additionally, there is a switch (S1) on the LaunchPad that is responsible for changing the melody. There are 8 different melody options (similar to the IEC60601-1-8 specification), and pressing the button will cycle through each of them. The parameters that can be changed during runtime are volume, priority level, and melody. The parameters that can be adjusted by changing variable values in the firmware are pulse spacing, pulse duration, burst spacing, and rise/fall time. The audio frequency can also be changed as desired.

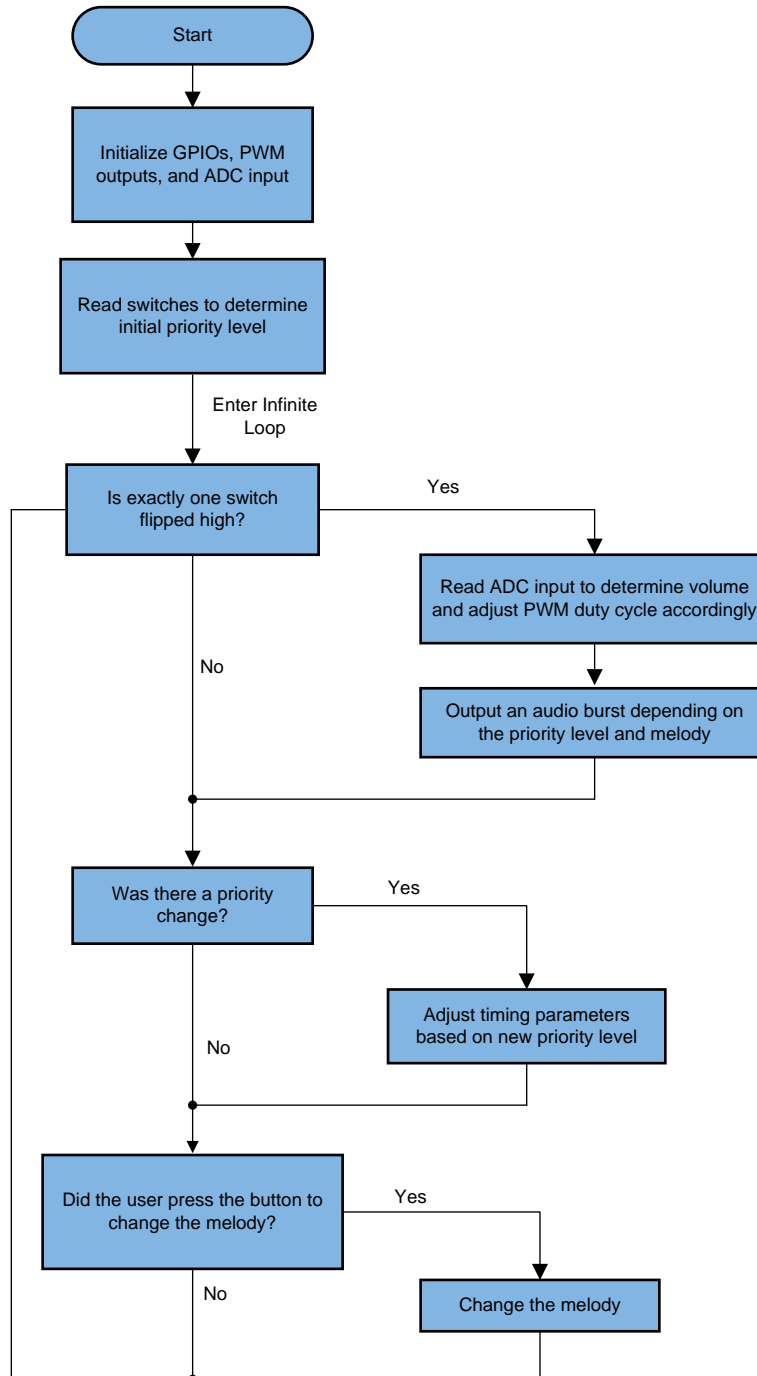
**图 15. Flow Chart**



## 3.2 Testing and Results

### 3.2.1 Test Setup

Use the following instructions for the test setup.

- Install Code Composer Studio™ version 7 or higher (Install to C:\ti).
- Open CCS.
- Click on the *File* option from the main toolbar and select *Import project*.
- Browse to select the downloaded firmware and click *OK*.
- Click on *Run and Debug*. This will program the board with the selected project file.

### 3.2.2 Test Results

Waveforms of the audio envelope are checked on U7 pin 6:

图 16 shows the switch selection that was used. The *Default Mode* setting corresponds to ccc cc or a general pattern is used. This is automatically loaded on power up.

图 16. High Priority



图 17 shows the high-priority burst with a duration of 2.84 seconds between two bursts.

图 17. High-Priority Interburst



图 18 shows the high-priority burst with a duration of 480 ms between the 5th and 6th pulses.

图 18. High-Priority Burst After 5 Pulses

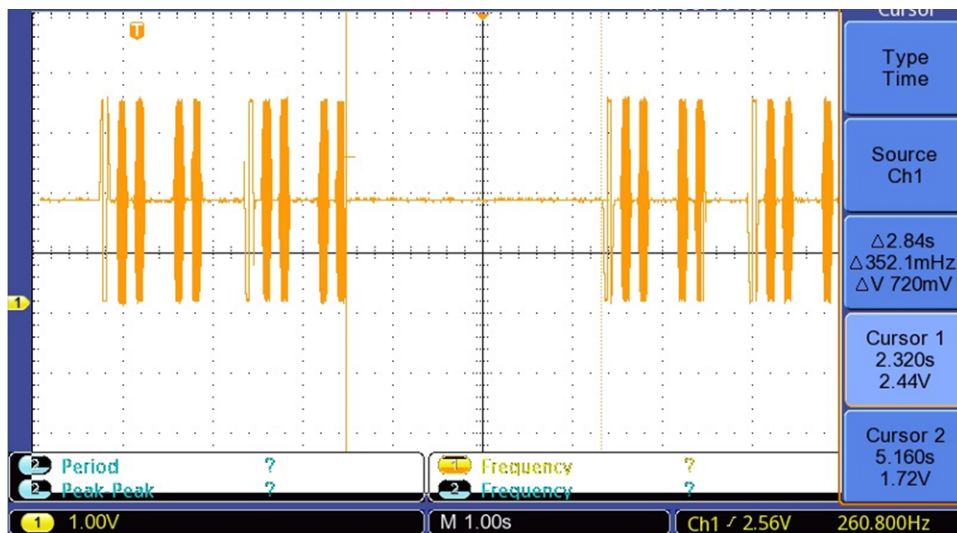

图 19 shows the high-priority burst with a duration of 76 ms between the 1st and 2nd pulses.

图 19. High-Priority Burst After 1 Pulse



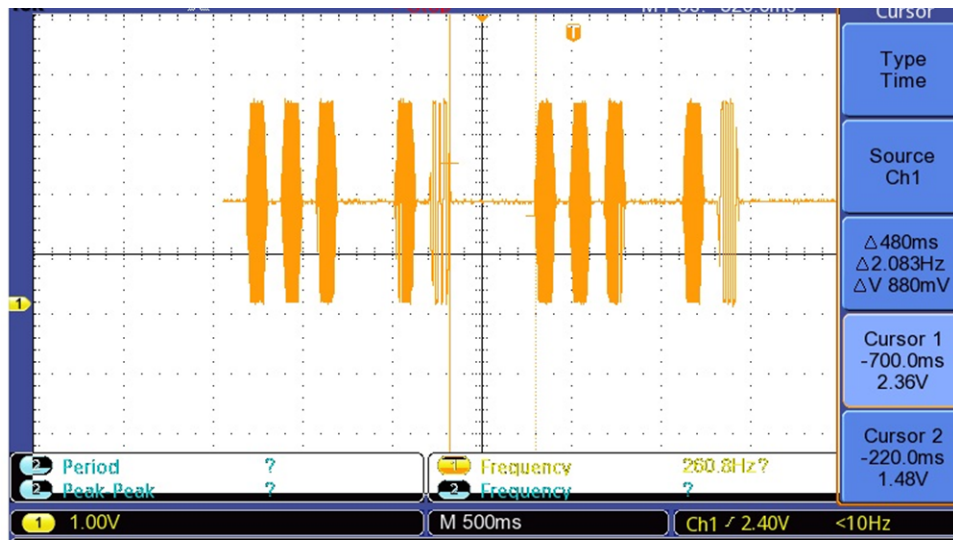

图 20 shows the high-priority burst with a duration of 320 ms between the 3rd and 4th pulses.

图 20. High-Priority Burst After 3 Pulses

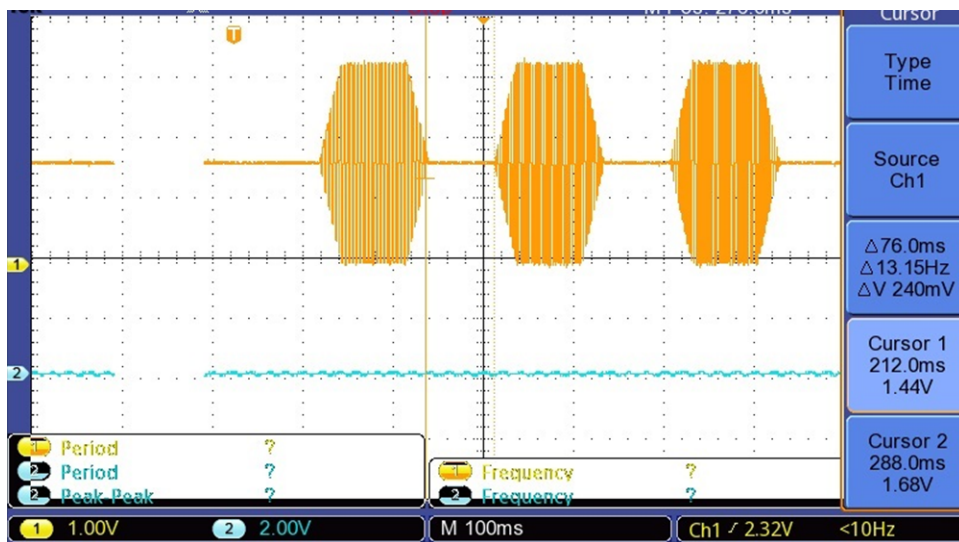

图 21 shows the rise time of the pulse of the high-priority burst as 23 ms.

图 21. High-Priority Burst Rise Time

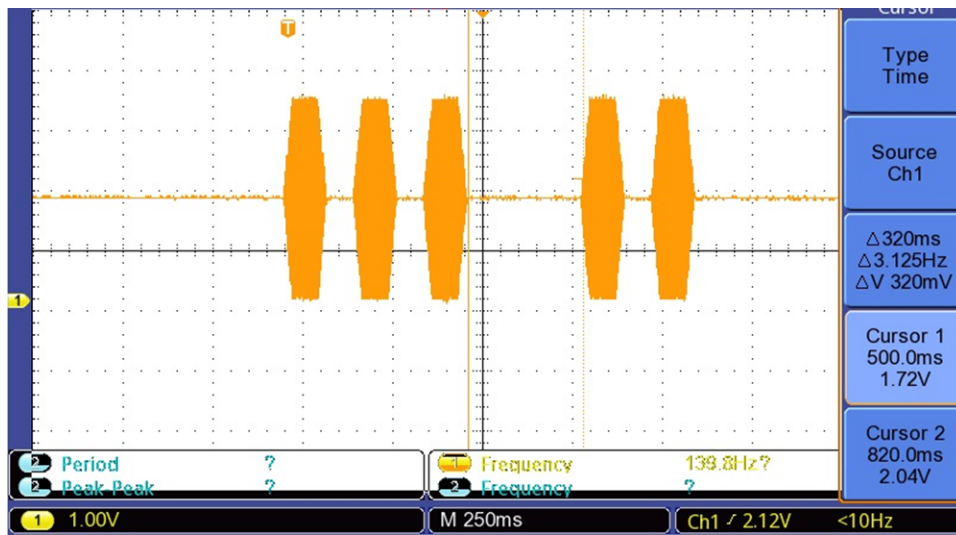

图 22 shows the high time of the pulse of the high-priority burst is 74 ms.

图 22. High-Priority Burst Pulse Width

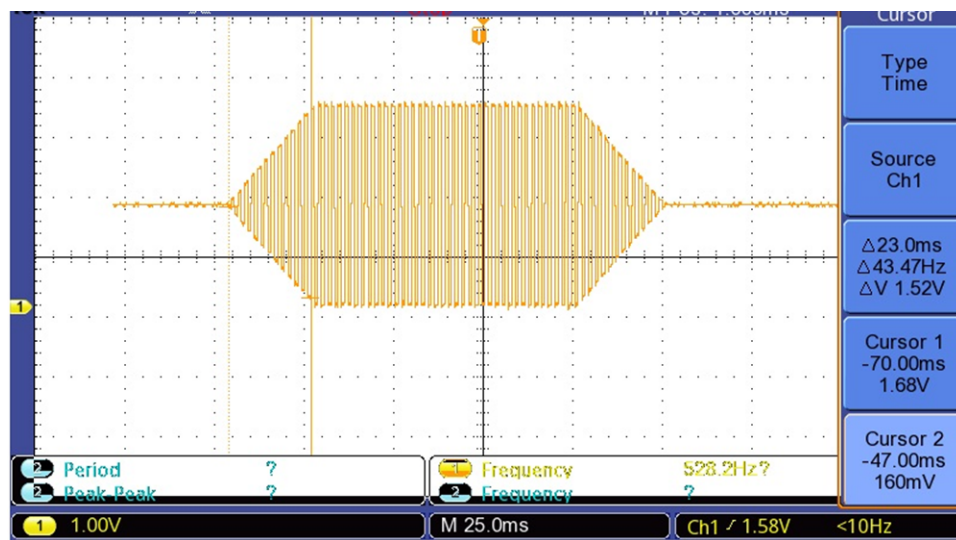

图 23 shows that the frequency inside of the pulse of the high-priority burst is 260 Hz. This corresponds to the c note.

图 23. High-Priority Burst Tone Frequency

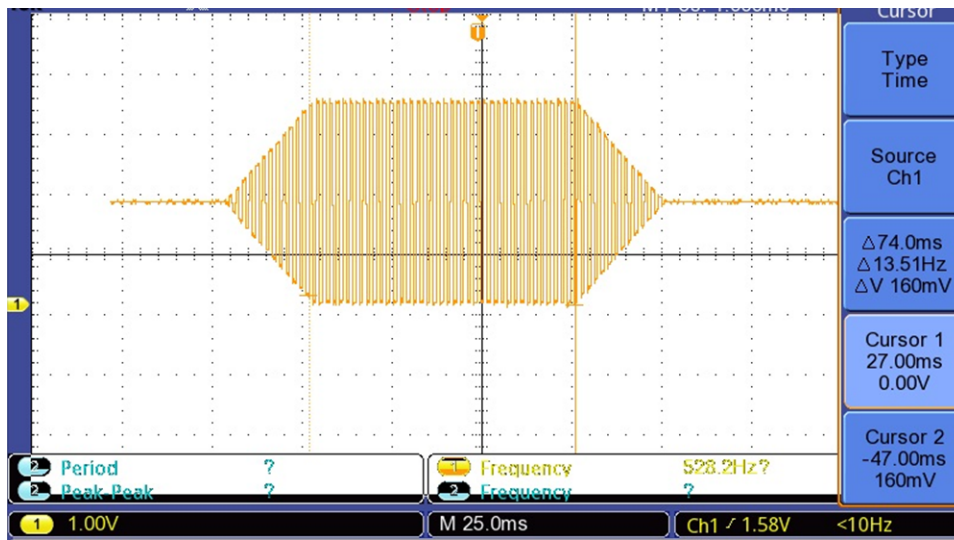

图 24 shows that the frequency inside of the pulse of the high-priority burst is 260 Hz. This corresponds to the c note. The FFT shows several harmonics corresponding to odd multiples of the fundamental of 260 Hz.

图 24. FFT High

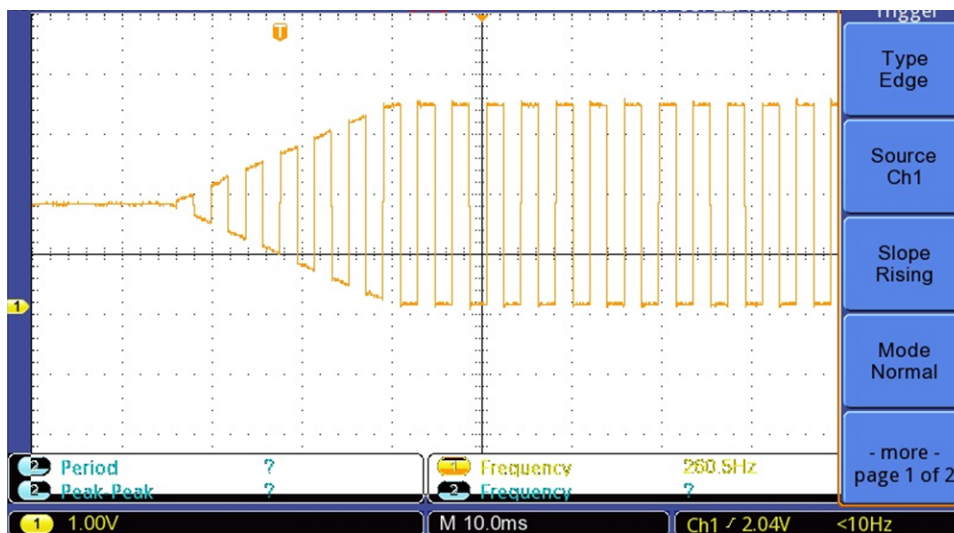

图 25 shows the switch selection that was used. The *Default Mode* setting corresponds to *ccc* or the general pattern that was used. This is automatically loaded on power up.

图 25. Switch Selection for Medium Priority

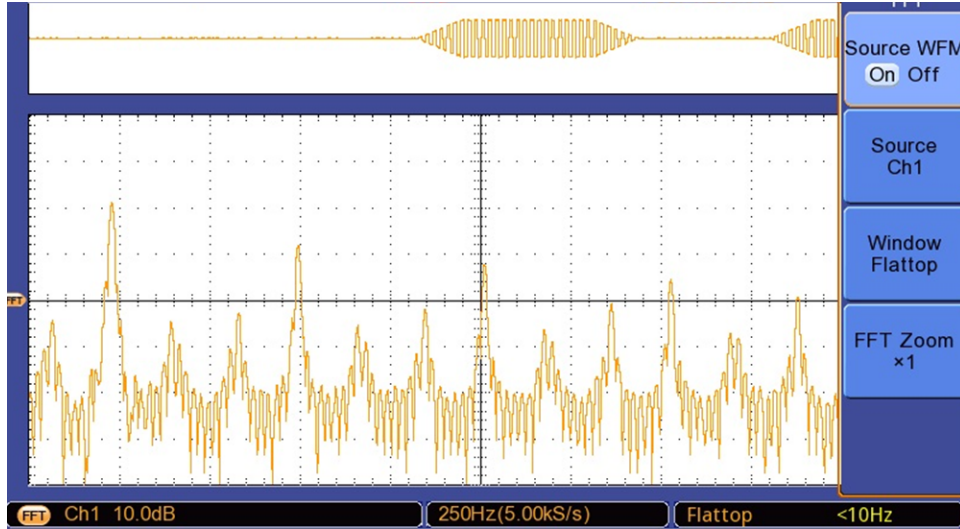

图 26 shows the medium-priority burst with a duration of 2.92 seconds between the first two bursts.

图 26. Interburst Medium



图 27 shows the width of the pulse of the medium-priority burst as 188 ms.

图 27. Pulse Width Medium

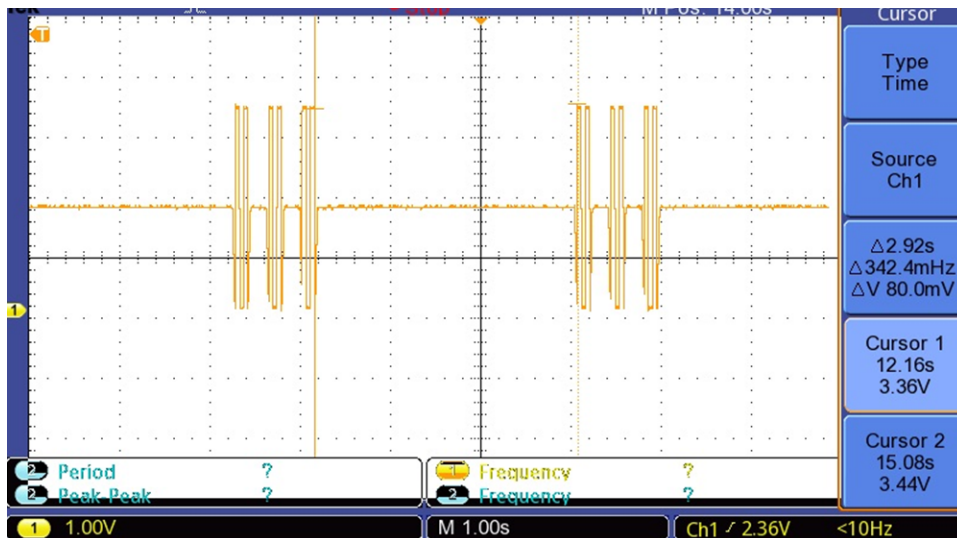

图 28 shows the rise time of the pulse of the medium-priority burst as 25 ms.

图 28. Rise Time Medium

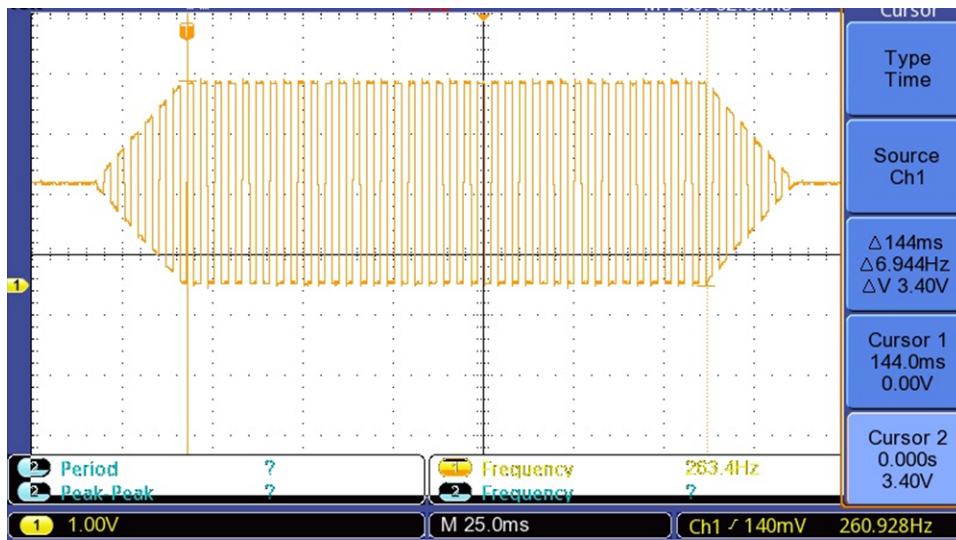

图 29 shows the duration between two pulses of the medium-priority burst as 188 ms.

图 29. Medium-Priority Burst After 3 Pulses

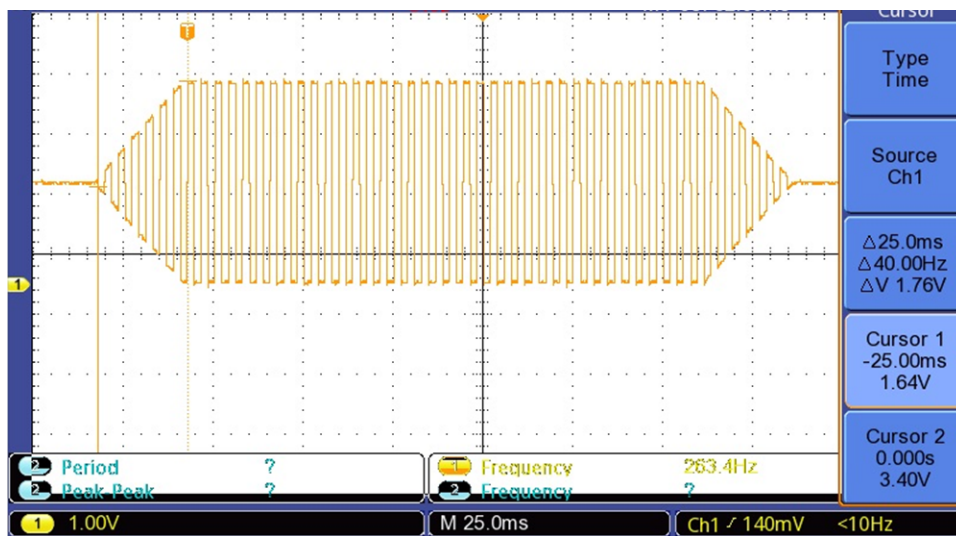

图 30 shows the frequency of medium-priority burst as 261 Hz.

图 30. Frequency Medium



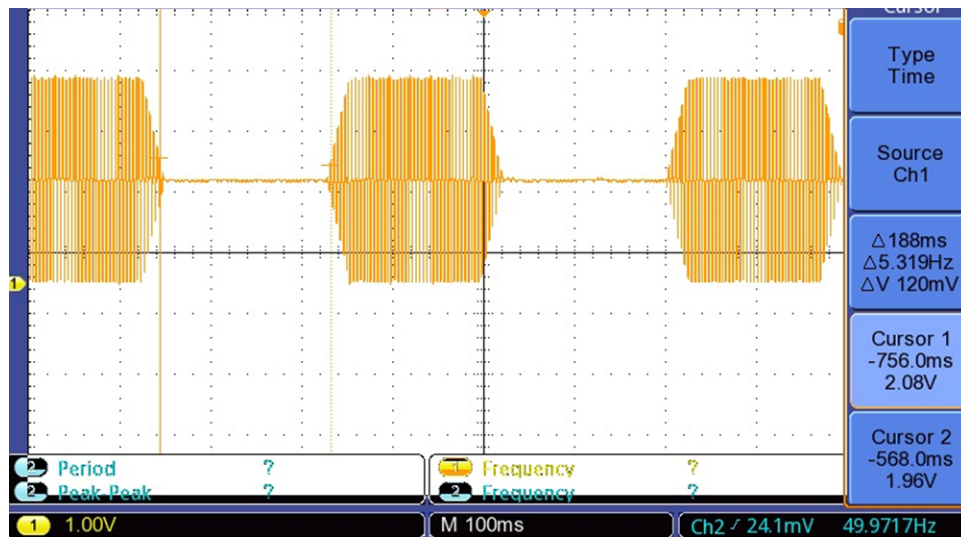

图 31 shows the frequency inside of the pulse of the medium-priority burst as 260 Hz. This corresponds to the c note. The FFT shows several harmonics that correspond to odd multiples of the fundamental of 260 Hz.

图 31. FFT Medium

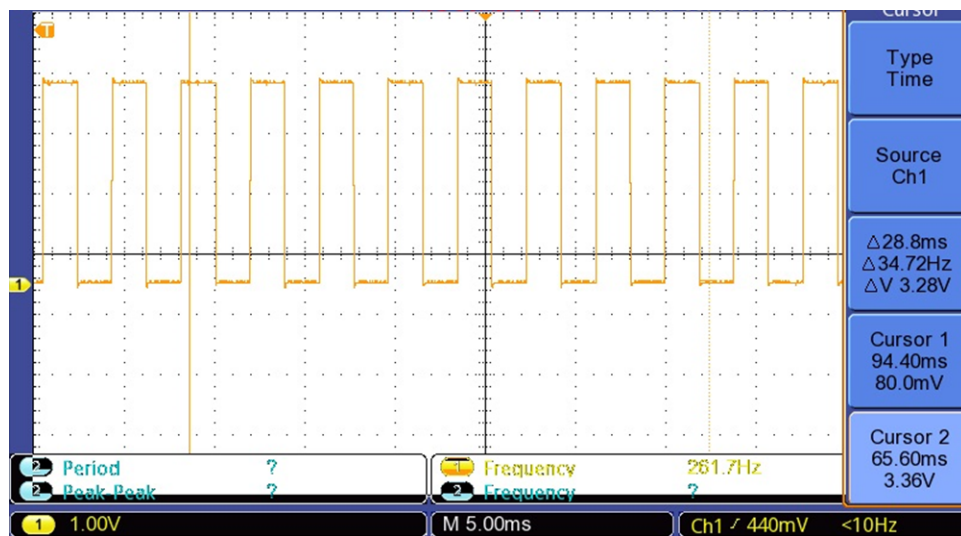

图 32 shows the switch selection that was used. The *Default Mode* setting corresponds to ec or any pattern that was used. This is automatically loaded on power up.

图 32. Low Priority

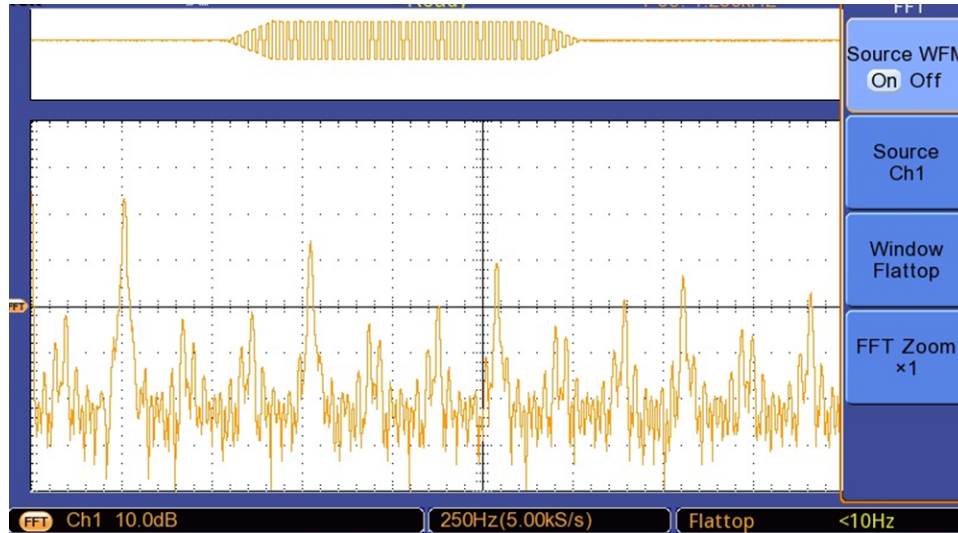

图 33 shows a duration of 1.4 seconds between low-priority bursts.

图 33. Interburst Low



图 34 shows a duration of 146 ms between two pulses of the low-priority bursts.

图 34. Low-Priority Bursts After 1 Pulse



图 35 shows a duration of 1.4 seconds between two low-priority bursts. This test was done only for demonstration. Actual low-priority signals have gaps greater than 15 seconds.

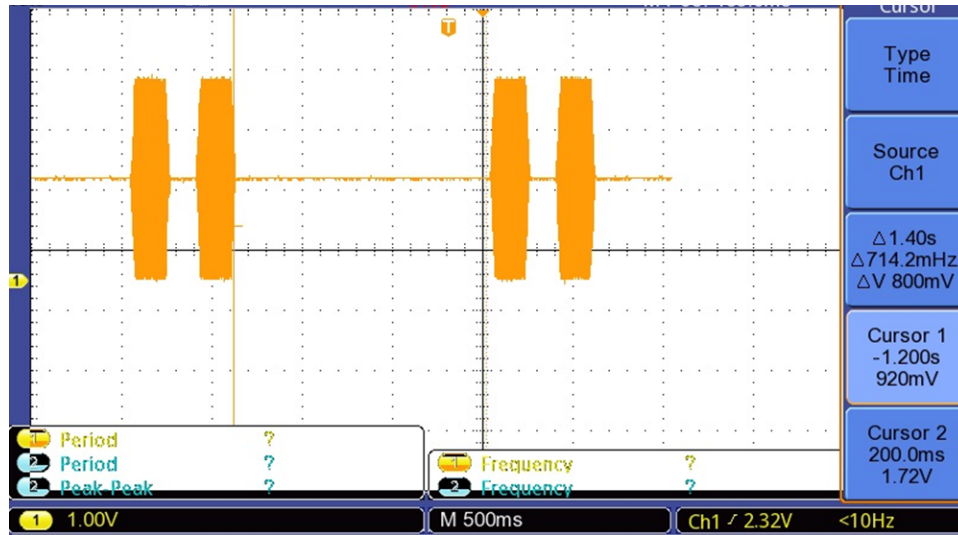

图 35. Interburst Low

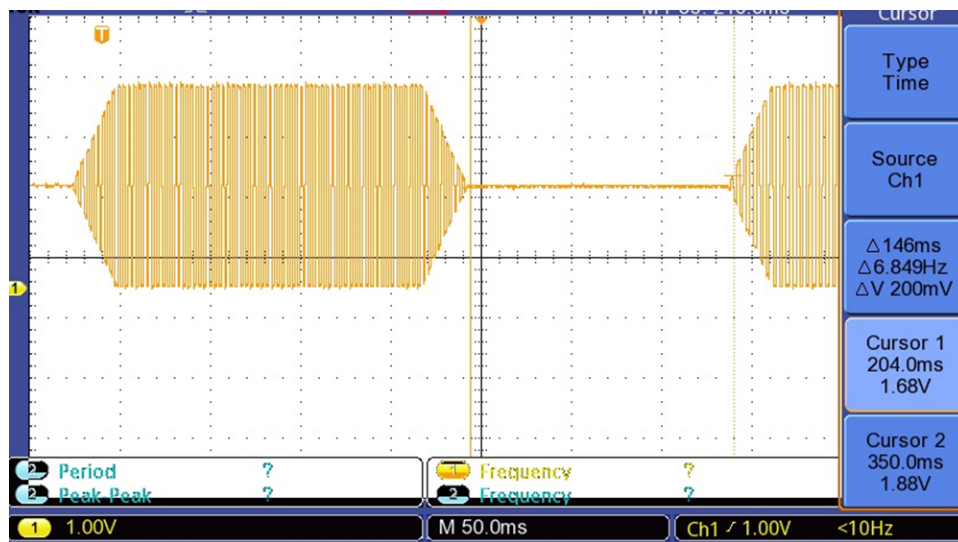

图 36 shows rise time of the low-priority bursts as 24 ms.

图 36. Rise Time Low

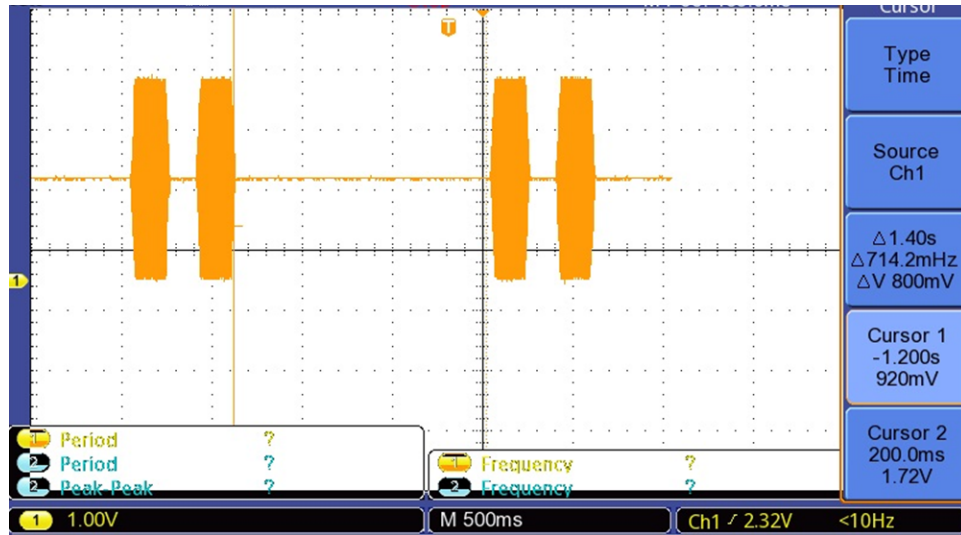

图 37 shows the width of the pulse for low-priority bursts as 168 ms.

图 37. Width Low

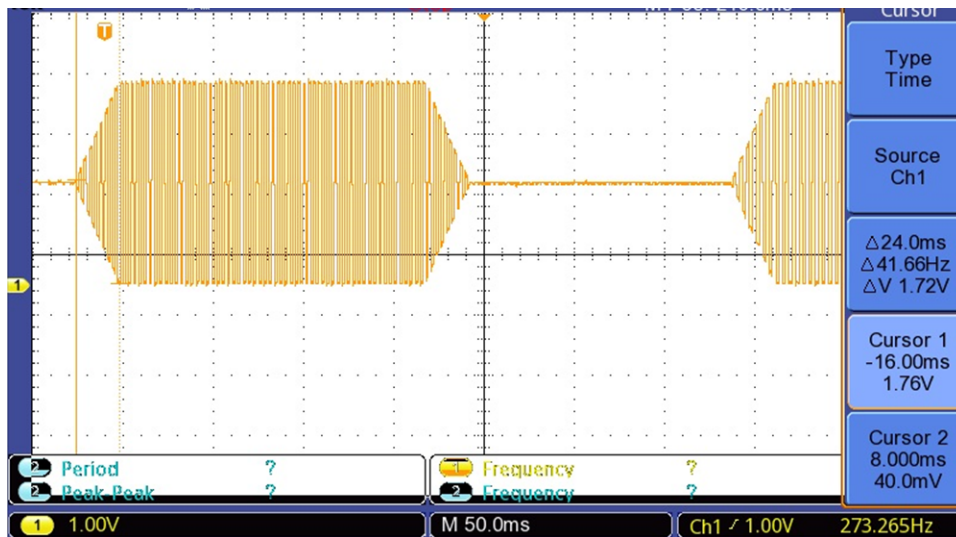

图 38 shows the second frequency of the low-priority burst as 272 Hz.

图 38. Frequency1 Low

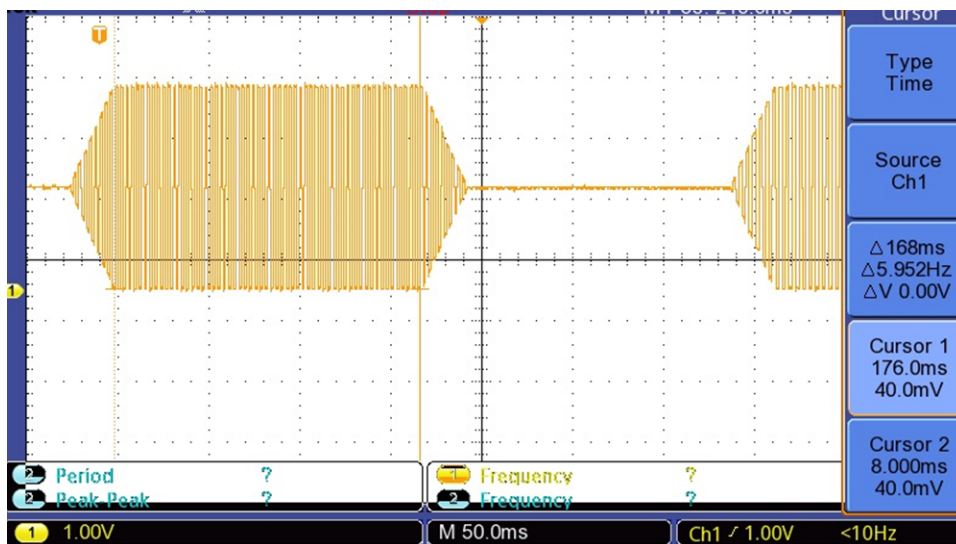

图 39 shows the second FFT frequency of the low-priority burst as 272 Hz.

图 39. FFT Low F1

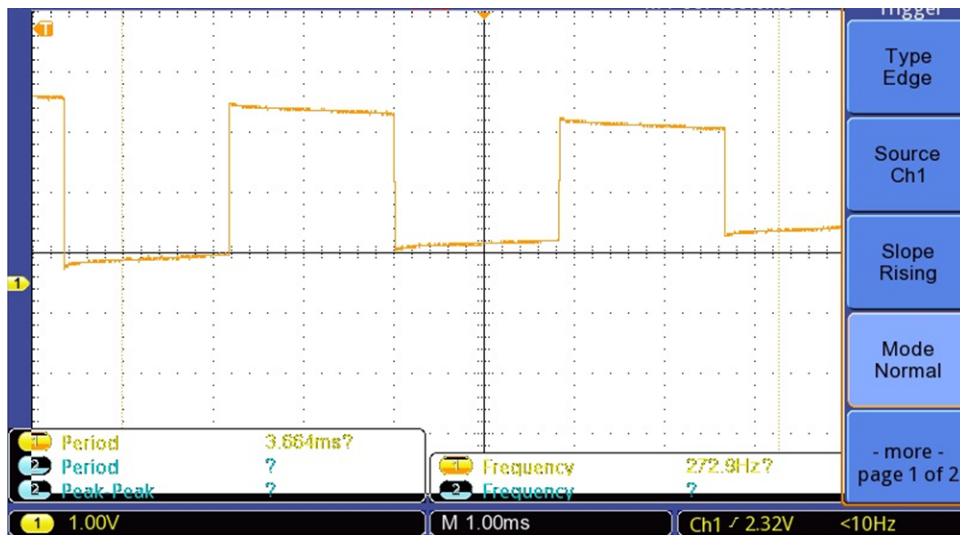

图 40 shows the second frequency of the low-priority burst as 345 Hz.

图 40. Frequency2 Low

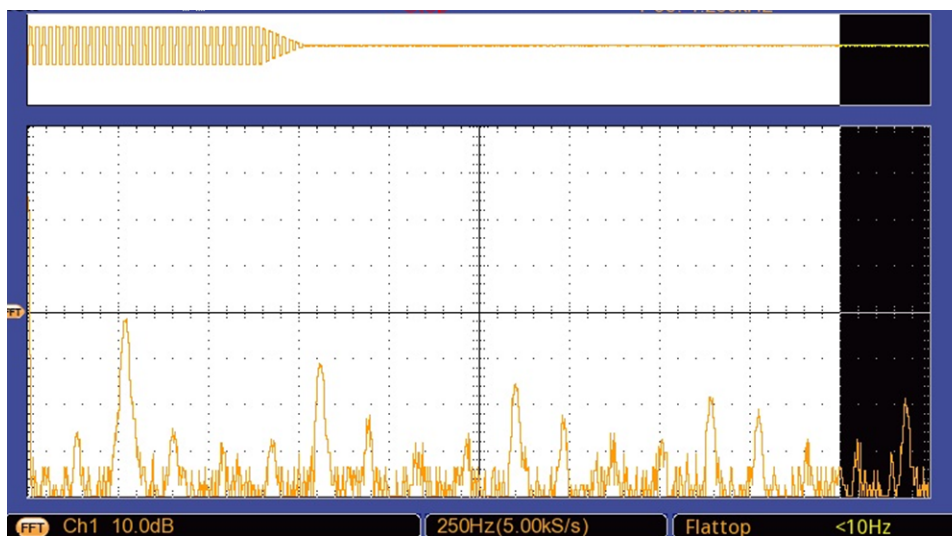

图 41 shows the waveform of the low-priority burst FFT as 345 Hz.

图 41. FFT2 LowF2

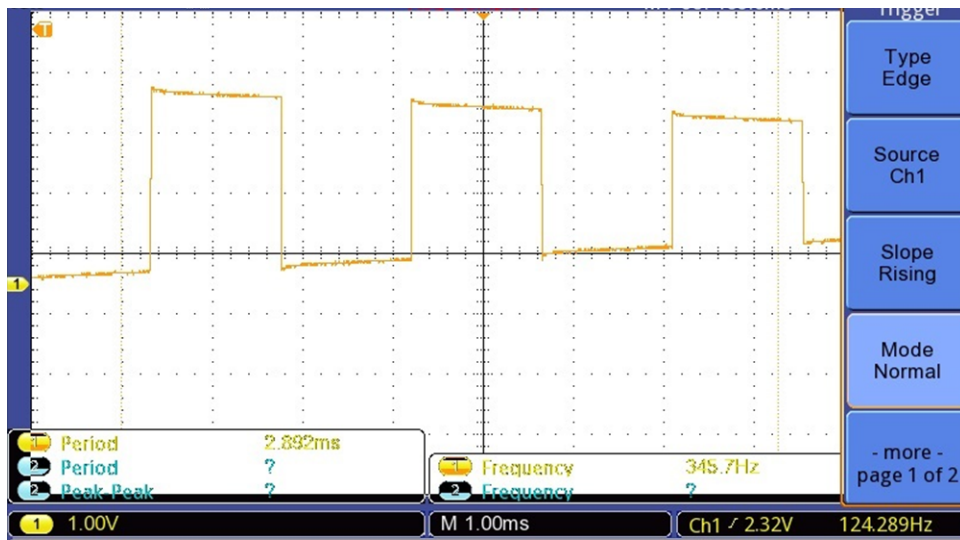
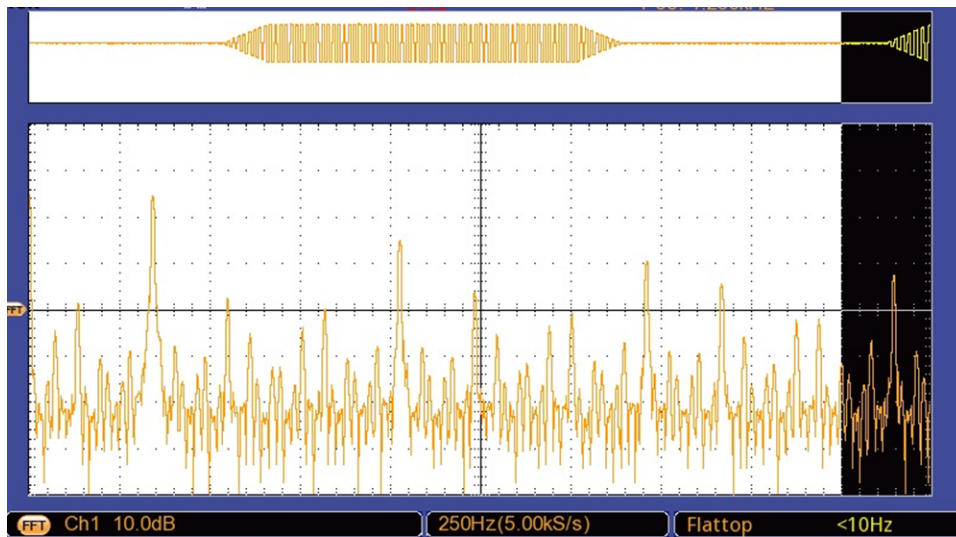

Waveform 2 is the peak envelope of the received microphone signal on pin 2 of U9A in 图 7. This waveform is received when the microphone is brought in close proximity to the speaker and the speaker is emitting an alarm sound. In this situation, onboard LED D2 is on permanently.

图 42. Coincidence 1

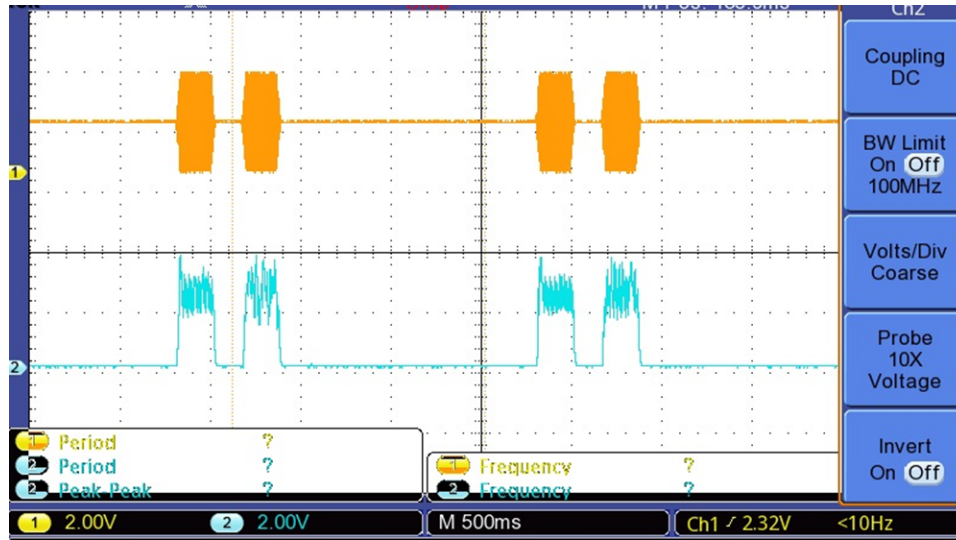

With a high-priority signal, the average current at LaunchPad input was 0.1 A as read by a multimeter.

## 4 Design Files

### 4.1 Schematics

To download the schematics, see the design files at [TIDA-010040](#).

### 4.2 Bill of Materials

To download the bill of materials (BOM), see the design files at [TIDA-010040](#).

### 4.3 PCB Layout Recommendations

#### 4.3.1 Layout Prints

To download the layer plots, see the design files at [TIDA-010040](#).

### 4.4 Altium Project

To download the Altium Designer® project files, see the design files at [TIDA-010040](#).

### 4.5 Gerber Files

To download the Gerber files, see the design files at [TIDA-010040](#).

### 4.6 Assembly Drawings

To download the assembly drawings, see the design files at [TIDA-010040](#).

## 5 Software Files

To download the software files, see the design files at [TIDA-010040](#).

## 6 Related Documentation

1. Texas Instruments, [MSP430FR231x Mixed-Signal Microcontrollers Data Sheet](#)
2. Texas Instruments, [TPA2005D1 1.4-W MONO Filter-Free Class-D Audio Power Amplifier Data Sheet](#)
3. Texas Instruments, [TS5A23157 Dual 10-  \$\Omega\$  SPDT Analog Switch Data Sheet](#)
4. IEC (2012). *IEC 60601-1-8: Medical electrical equipment*. Geneva, Switzerland.

### 6.1 商标

E2E, LaunchPad, Code Composer Studio are trademarks of Texas Instruments.  
Altium Designer is a registered trademark of Altium LLC or its affiliated companies.  
All other trademarks are the property of their respective owners.

### 6.2 Third-Party Products Disclaimer

TI'S PUBLICATION OF INFORMATION REGARDING THIRD-PARTY PRODUCTS OR SERVICES DOES NOT CONSTITUTE AN ENDORSEMENT REGARDING THE SUITABILITY OF SUCH PRODUCTS OR SERVICES OR A WARRANTY, REPRESENTATION OR ENDORSEMENT OF SUCH PRODUCTS OR SERVICES, EITHER ALONE OR IN COMBINATION WITH ANY TI PRODUCT OR SERVICE.

## 重要声明和免责声明

TI 均以“原样”提供技术性 & 可靠性数据（包括数据表）、设计资源（包括参考设计）、应用或其他设计建议、网络工具、安全信息和其他资源，不保证其中不含任何瑕疵，且不做任何明示或暗示的担保，包括但不限于对适销性、适合某特定用途或不侵犯任何第三方知识产权的暗示担保。

所述资源可供专业开发人员应用 TI 产品进行设计使用。您将对以下行为独自承担全部责任：(1) 针对您的应用选择合适的 TI 产品；(2) 设计、验证并测试您的应用；(3) 确保您的应用满足相应标准以及任何其他安全、安保或其他要求。所述资源如有变更，恕不另行通知。TI 对您使用所述资源的授权仅限于开发资源所涉及 TI 产品的相关应用。除此之外不得复制或展示所述资源，也不提供其它 TI 或任何第三方的知识产权授权许可。如因使用所述资源而产生任何索赔、赔偿、成本、损失及债务等，TI 对此概不负责，并且您须赔偿由此对 TI 及其代表造成的损害。

TI 所提供产品均受 TI 的销售条款 (<http://www.ti.com.cn/zh-cn/legal/termsofsale.html>) 以及 [ti.com.cn](http://www.ti.com.cn) 上或随附 TI 产品提供的其他可适用条款的约束。TI 提供所述资源并不扩展或以其他方式更改 TI 针对 TI 产品所发布的可适用的担保范围或担保免责声明。

邮寄地址：上海市浦东新区世纪大道 1568 号中建大厦 32 楼，邮政编码：200122  
Copyright © 2019 德州仪器半导体技术（上海）有限公司



## 重要声明和免责声明

TI 均以“原样”提供技术性 & 可靠性数据（包括数据表）、设计资源（包括参考设计）、应用或其他设计建议、网络工具、安全信息和其他资源，不保证其中不含任何瑕疵，且不做任何明示或暗示的担保，包括但不限于对适销性、适合某特定用途或不侵犯任何第三方知识产权的暗示担保。

所述资源可供专业开发人员应用 TI 产品进行设计使用。您将对以下行为独自承担全部责任：(1) 针对您的应用选择合适的 TI 产品；(2) 设计、验证并测试您的应用；(3) 确保您的应用满足相应标准以及任何其他安全、安保或其他要求。所述资源如有变更，恕不另行通知。TI 对您使用所述资源的授权仅限于开发资源所涉及 TI 产品的相关应用。除此之外不得复制或展示所述资源，也不提供其它 TI 或任何第三方的知识产权授权许可。如因使用所述资源而产生任何索赔、赔偿、成本、损失及债务等，TI 对此概不负责，并且您须赔偿由此对 TI 及其代表造成的损害。

TI 所提供产品均受 TI 的销售条款 (<http://www.ti.com.cn/zh-cn/legal/termsofsale.html>) 以及 [ti.com.cn](http://www.ti.com.cn) 上或随附 TI 产品提供的其他可适用条款的约束。TI 提供所述资源并不扩展或以其他方式更改 TI 针对 TI 产品所发布的可适用的担保范围或担保免责声明。

邮寄地址：上海市浦东新区世纪大道 1568 号中建大厦 32 楼，邮政编码：200122  
Copyright © 2019 德州仪器半导体技术（上海）有限公司