

设计指南: TIDC-HYBRID-WMBUS-PLC 采用基于标准的协议扩展网络覆盖范围和可靠性参考设计



说明

随着先进抄表基础设施 (AMI) 和配电自动化网络中的准时响应和监控越来越重要, 人们对可靠性通信的要求也有所提高。由于服务运营商和管理机构对互操作性的利用, 基于标准的通信逐渐成为大多数智能电网开发中的一项要求。此参考设计通过采用基于标准的无线 M-Bus 和 G3-PLC 电力线通信 (PLC) 的解决方案, 不仅可以解决这些问题,

还能帮助提高网络性能、可靠性、容量和可扩展性。CC13xx 无线 MCU 用作射频协议处理器和 PLC 处理器的主机, 从而可以额外节约系统设计成本。此设计基于采用 G3-PLC 的无线 M-Bus 射频解决方案。要查看基于 TI 专有射频解决方案的版本, 请参阅 [TIDC-HYBRID-RF-PLC 设计](#)。

资源

TIDC-HYBRID-WMBUS-PLC	设计文件夹
CC310	产品文件夹
F28PLC84	产品文件夹
F28375S	产品文件夹
F28M35H52C	产品文件夹
AFE031	产品文件夹
AFE032	产品文件夹
TMDSPCLKITV4-CEN	工具文件夹
LAUNCHXL-CC1310	工具文件夹
TI-PLC-G3-CENELEC-SN	工具文件夹
SIMPLELINK-CC13X0-SDK	工具文件夹
WMBUS	工具文件夹

特性

- 通过经无线 M-Bus 网络和 PLC 网络同时传输提高网络可靠性
- 使用无线 M-Bus 和 PLC 网络同时传输独立数据, 通过空间多路复用提高网络容量
- 通过用作无线 M-Bus 网络和 PLC 网络之间的桥接器, 扩展区域内的覆盖范围, 从而提高网络可扩展性。
- 完全可编程的协议设计可提供各种选项: CENELEC、ARIB 和 FCC 频段上的 PLC/无线 M-Bus 通信协议 (PRIME、G3-PLC 和 PLC-Lite) 以及 868MHz 频段上的无线 M-Bus C/T/S 模式 TRX 支持

应用

- 配电自动化
- 智能仪表
- 智能插头
- 智能电网通信



[Search Our E2E™ support forums](#)

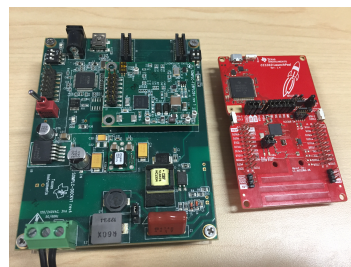
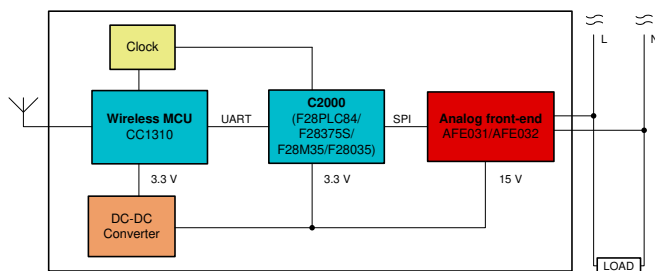



该 TI 参考设计末尾的重要声明表述了授权使用、知识产权问题和其他重要的免责声明和信息。

1 System Description

This design provides a reliable communication system solution with standard-based wireless M-Bus and PLC communications for end equipment of smart grid applications. This design is built on top of the existing TI PLC and wireless M-Bus solutions, which improves network performance and provides more features by combining the communication modems and the inherited advantages from the existing PLC and wireless M-Bus solutions.

The ARM® Cortex™-M3 processor in the CC1310 Simplelink™ wireless microcontroller (MCU) is the CPU that controls the RF and PLC links. In this design, the CC1310 Wireless MCU is connected to the C2000 PLC MCU through UART and acts as the external host processor for the PLC modem. The PLC MCU is loaded with the G3-PLC stacks. The wireless MCU also runs the host applications for the system by simultaneously transmitting packets on both networks or acting as a bridge between the different physical networks. [Section 4](#) describes the hybrid wireless M-Bus PLC example project that uses this architecture.

图 1 显示了无线 M-Bus 与 G3-PLC 全栈基于的系统架构。

图 1. System Architecture (Wireless M-Bus With PLC)

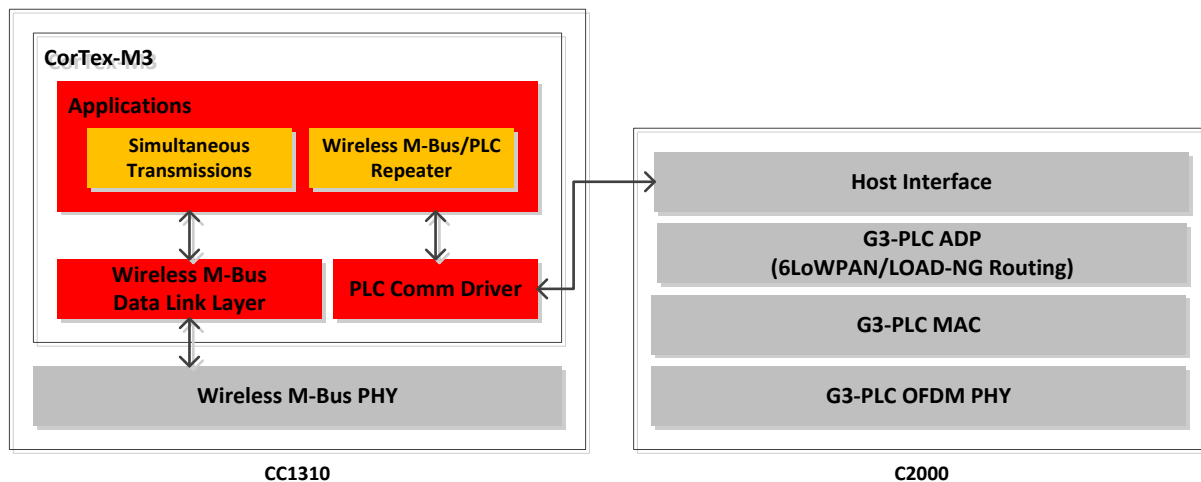

2 Block Diagrams

The primary devices for this design are CC1310, TMS320F28PLC84, and AFE031. The CC1310 includes two core processors: ARM™ Cortex-M0 for RF communication and ARM™ Cortex-M3 for applications, network stacks, and host-level RF/PLC communication drivers. The TMS320F28PLC84 with AFE031 (PLC analog front end) is for PLC communication.

Figure 2 shows the block diagram.

图 2. Block Diagram

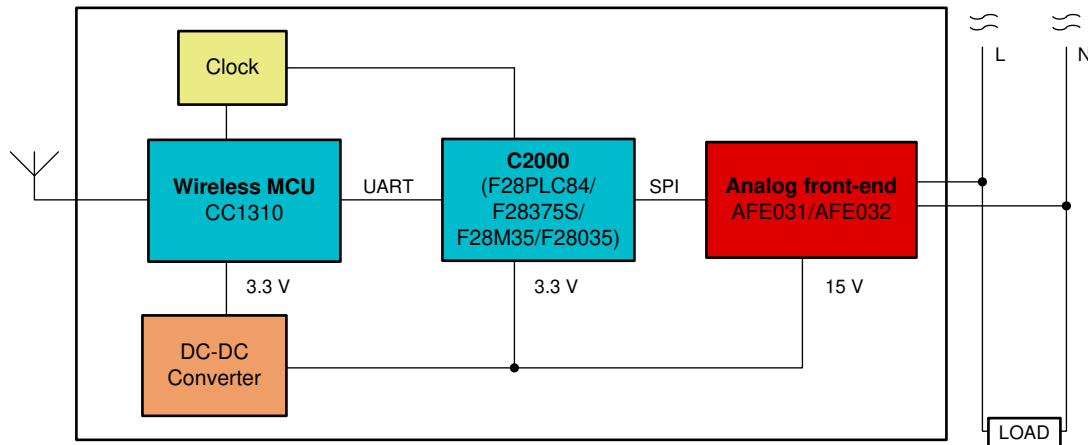

2.1 Highlighted Products

The Reference Design features the following devices:

- CC1310 combines a flexible, low-power RF transceiver with a powerful 48-MHz ARM™ Cortex-M3 microcontroller in a platform supporting wireless M-Bus stacks.
- TMS320F28PLC84 provides optimized PLC OFDM performance with VCU and allows programmable, flexible PLC design that may upgrade to different PLC solutions without hardware modification.
- AFE031 provides high reliability for PLC applications by using a monolithic integrated circuit with thermal and overcurrent protection.

For more information on each of these devices, refer to the [TIDC-HYBRID-WMBUS-PLC](#) product folders.

2.1.1 CC1310

The device is a member of the CC26xx and CC13xx families of cost-effective, ultra low-power, 2.4 GHz and sub 1-GHz RF devices. Low active RF, MCU current, and low-power mode current consumption provide excellent battery lifetime and allow operation on small coin-cell batteries and energy-harvesting applications. The CC1310 device is the first part in a Sub-1 GHz family of cost-effective, ultra low-power wireless MCUs. The CC1310 device combines a flexible, low-power RF transceiver with a powerful 48-MHz Cortex M3 MCU in a platform that supports multiple physical layers and RF standards. A dedicated radio controller (Cortex-M0) handles low-level RF protocol commands that are stored in ROM or RAM, which ensures ultra low-power and flexibility. The low-power consumption of the CC1310 device does not come at the expense of RF performance—the CC1310 device has excellent sensitivity, selectivity and blocking performance. The CC1310 device is a highly integrated, single-chip solution that incorporates a complete RF system and an on-chip DC-DC converter. Sensors may be handled in a low-power manner by a dedicated autonomous ultra low-power MCU that may be configured to handle analog and digital sensors, so the main MCU (Cortex-M3) may maximize sleep time. The CC1310 power, clock

management, and radio systems require specific configuration and software handling to operate correctly. This has been implemented in the TI RTOS, and TI recommends that this software framework is used for all application development on the device. The CC1310 includes an Advanced Encryption Standard (AES) engine with 128-bit key support. In addition, the source code offers the complete TI-RTOS and device drivers.

Figure 3 shows the block diagram.

图 3. CC1310 Functional Block Diagram

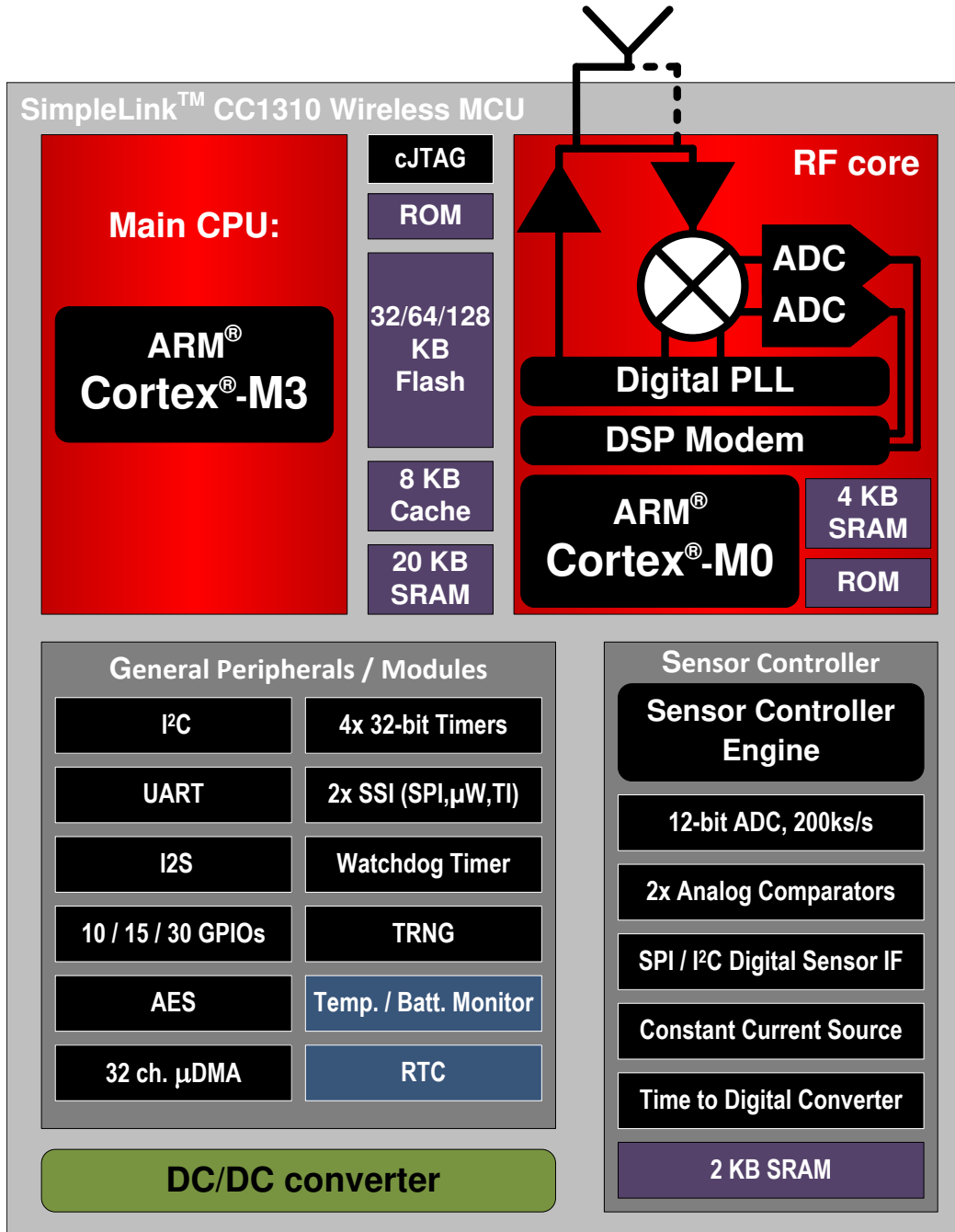

2.1.2 TMS320F28PLC84

The TMS320F28PLC84 PLC processors are optimized to meet the requirements for AMI networks in Smart Grid installations that will use narrowband PLC in the CENELEC frequency band. The CENELEC band is defined to range from 35 kHz to 90 kHz. The F28PLC84 processor is designed to execute the entire PLC protocol stack for the supported industry standards. TI supplies these firmware libraries to execute on the F28PLC84 processor with no additional license fees or royalties. The F28PLC84 processor is also used in PLC data concentrators, which act as neighborhood-area collectors of electricity usage information from multiple end nodes. The F28PLC84 processors are optimized to work with the AFE031 analog front end for the PLC. The AFE031 is an integrated analog front end for narrowband PLC that may drive a transformer-coupled connection to the AC Mains power line. It is ideal for driving high-current, low-impedance lines driving up to 1.9 A into reactive loads. The AFE031 is compliant with CENELEC A, B, C, and D (EN50065-1, -2, -3, -7) frequency bands.

Figure 4 shows the functional block diagram.

图 4. TMS320F28PLC Functional Block Diagram

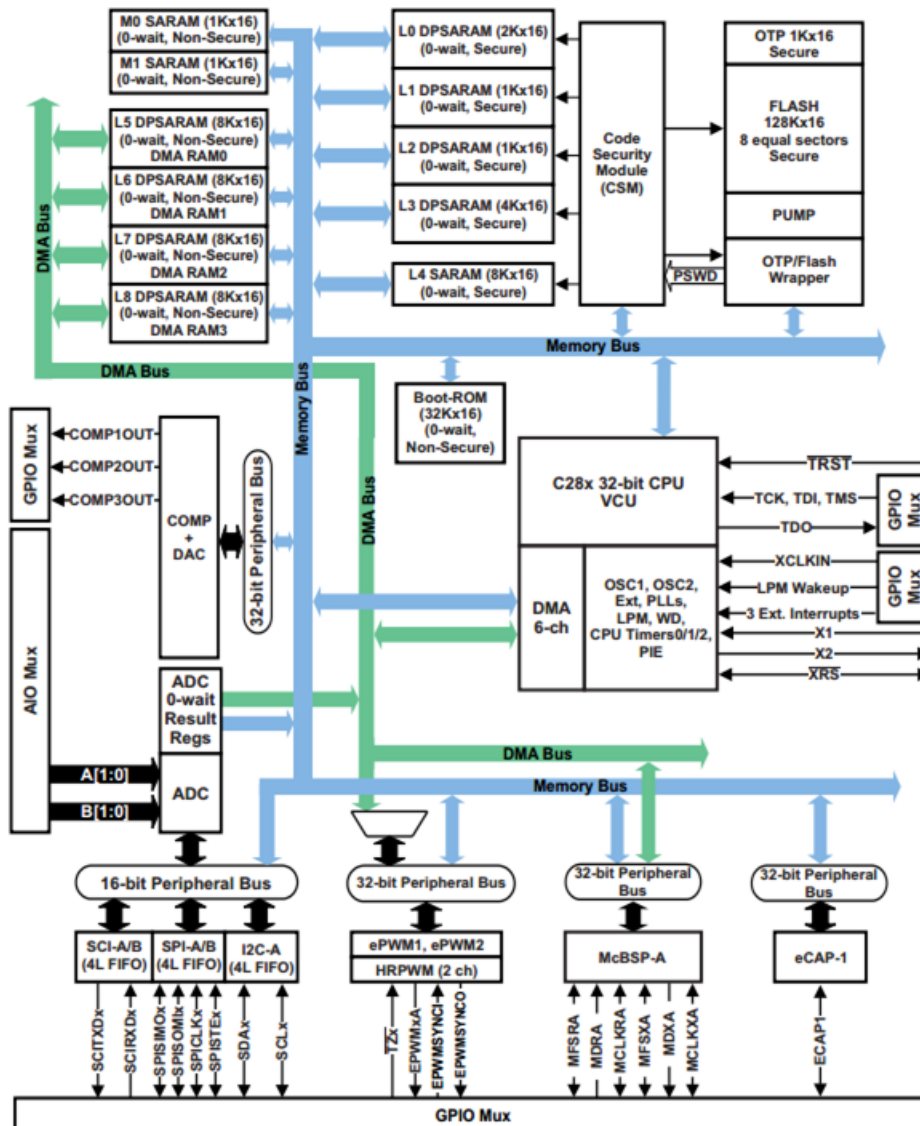

2.1.3 AFE031

The AFE031 is a low-cost, integrated, PLC analog front-end device that is capable of capacitive or transformer-coupled connections to the powerline while controlled by a DSP or microcontroller. It is ideal for driving low-impedance lines that require up to 1.5 A in reactive loads. The integrated receiver may detect signals down to 20 μ V_{RMS} and is capable of a wide range of gain options to adapt to varying input signal conditions. This monolithic integrated circuit provides high reliability in demanding powerline communications applications. The AFE031 transmit power amplifier operates from a single supply from 7 V — 24 V. At maximum output current, a wide output swing provides a 12-V_{PP} ($I_{OUT} = 1.5$ A) capability with a nominal 15-V supply. The analog and digital signal processing circuitry operates from a single 3.3-V power supply.

The AFE031 is internally protected against over temperature and short-circuit conditions. It also provides an adjustable current limit. The provided interrupt output indicates the current limit and thermal limit. There is also a shutdown pin that may quickly put the device into its lowest power state. Through the four-wire serial peripheral interface, or SPI™, each functional block may be enabled or disabled to optimize power dissipation. The AFE031 is housed in a thermally-enhanced, surface-mount Power PAD package (QFN-48). Operation is specified over the extended industrial junction temperature range of -40°C to 125°C.

Figure 5 shows the functional block diagram.

图 5. AFE031 Functional Block Diagram

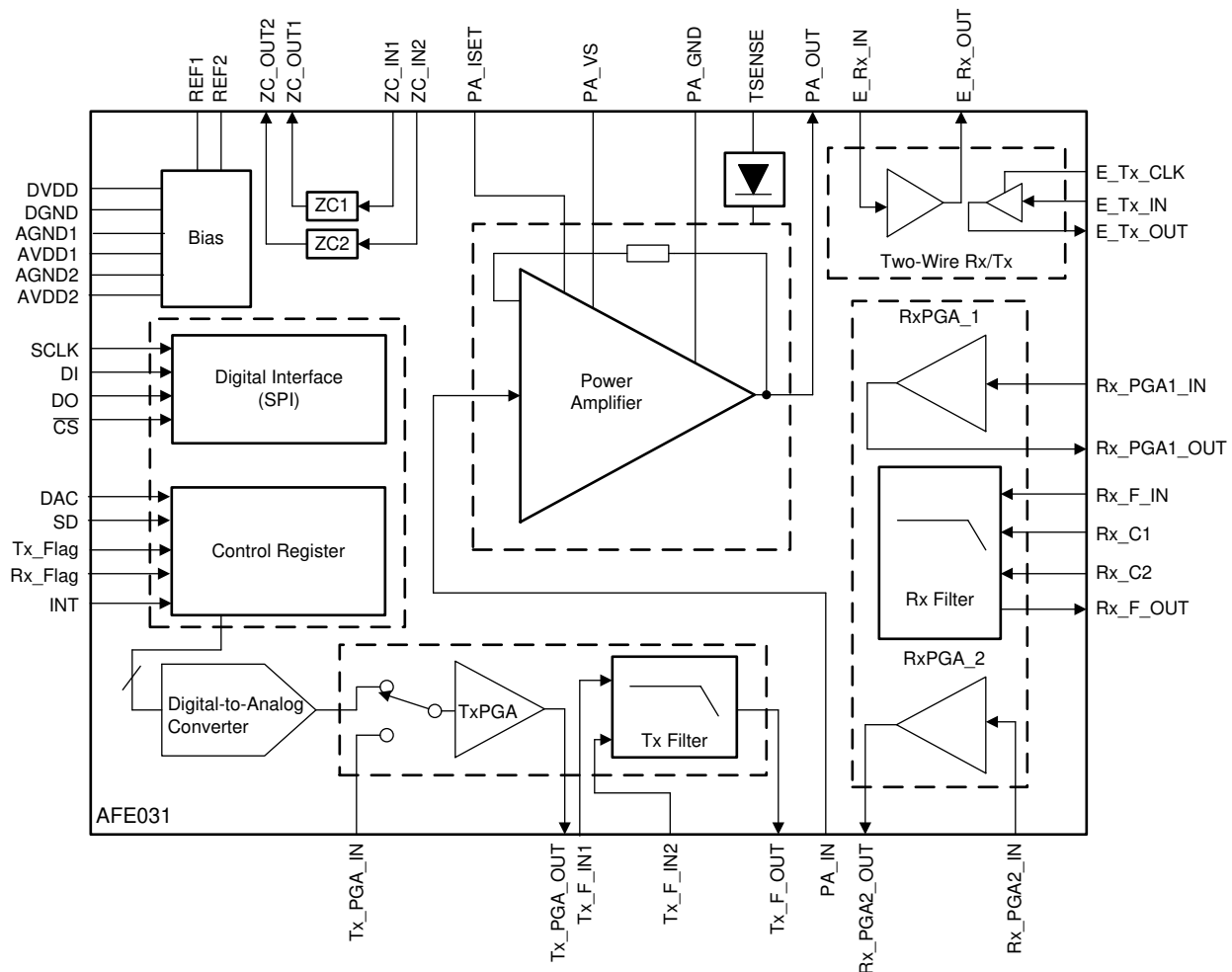

3 Getting Started Hardware

The hybrid wireless M-Bus and PLC communications design are built with two standard EVMs: [LAUNCHXL-CC1310](#) and [TMDSPCLKITV4-CEN](#), as shown respectively in [Figure 6](#) and [Figure 7](#).

The reference design configures as CENELEC-A band in software with a TMDSPCLKITV4-CEN platform for the PLC. Depending on user applications, [TIDM-SOMPLC-FCC](#) or [TMDSPCLKITV4-ARIB](#) may work with the LAUNCHXL-CC1310.

图 6. LAUNCHXL-CC1310



图 7. TMDSPCLKITV4-CEN



3.1 EVM Configuration

The major hardware modification on the hybrid wireless M-Bus or PLC system is to connect the UART pins (UART_TX, UART_RX and GND) between the LAUNCHXL-CC1310 and the TMDSPCKITV4 EVM.

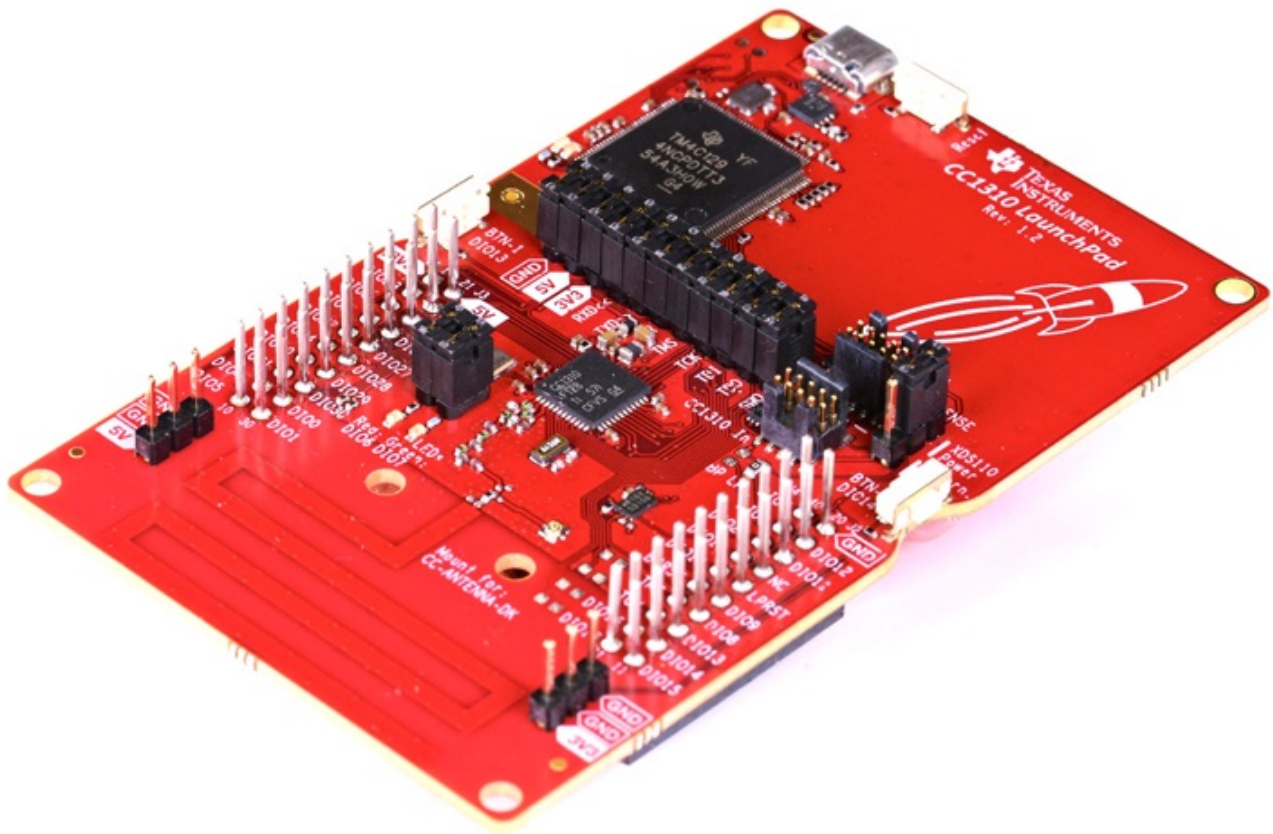
- Figure 8 shows UART pins on the TMDSPCKITV4 connected to the LAUNCHXL-CC1310.
- The M3:P2-12 (PLC_SCIA_TX) pin in Figure 8 is connected to UART RX pin (DIO 2) on the LAUNCHXL-CC1310.
- M3:P2-14 (PLC_SCIA_RX) (Figure 8) connects to UART TX pin (DIO 3) on the LAUNCHXL-CC1310.
- The GND pin in the TMDSPCKITV4 EVM, as shown in Figure 8, is connected to GND pin on the LAUNCHXL-CC1310.

图 8. UART Pins on TMDSPCKITV4

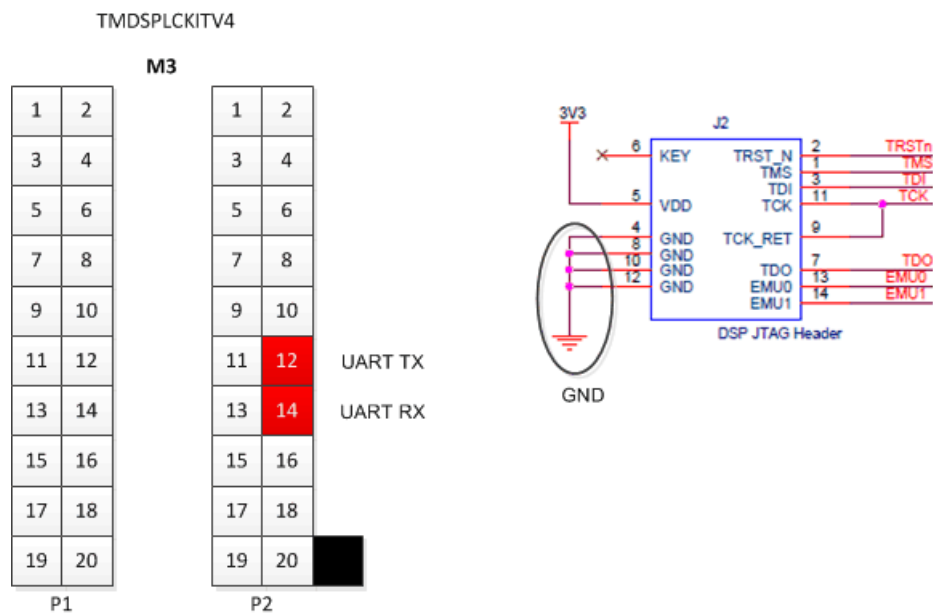

As Figure 10 shows , an additional configuration change is to switch the SW2 position to OFF. Turning off the SW2 blocks UART communication with the mini-USB port in TMDSPCKITV4, which allows the M3 module to communicate with the external device through the UART without interruptions.

图 9. SW2 Position in TMDSPCKITV4 EVM

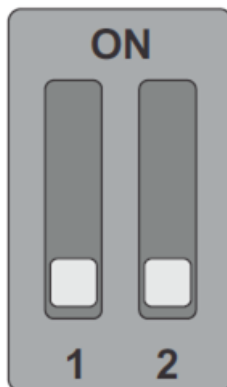

4 Getting Started Firmware

This reference design provides a HYBRID-WMBUS-PLC software example which includes applications for simultaneous transmissions, repeaters, wireless M-Bus lower-layer stacks and PLC communication host drivers. This section covers details of the example software architecture, and how to build and flash the example project using the TI Code Composer Studio™ (CCS) software.

The software example can be built with CCS v9.0.1 (or above). 图 10 and 图 11 show the compiler and CC13x0 SDK versions (SIMPLELINK-CC13X0-SDK v3.10.0.11) used to compile the software example.

图 10. Software Example Compiler Version



图 11. Software Example CC1310 SDK Version



4.1 TIDC-HYBRID-WMBUS-PLC Software Example

This example project is provided as a working example that may be used as baseline software for end-product development. The example runs on top of TI-RTOS in the ARM™ Cortex-M3. For PLC communication, the default configuration in the example is set to CENELEC-A, TMR ON and the TX level of 0x20 (maximum). The wireless M-Bus RF configuration is defined in `smartrf_setting.c`. The pre-compiled binaries are available in the directory of `debug`. The wireless M-Bus can be configured as one of three modes C-, T-, or S-mode) by enabling one of them in `application/config.h`. The `debug_RF_only` configuration run a standalone W-Mbus communication to test with the Hybrid W-Mbus and PLC solution. The `debug_RF_only` configuration enables `ECHO_BACK_MODE` macro to respond back to the Hybrid WMBUS-PLC node with the same data received from the node.

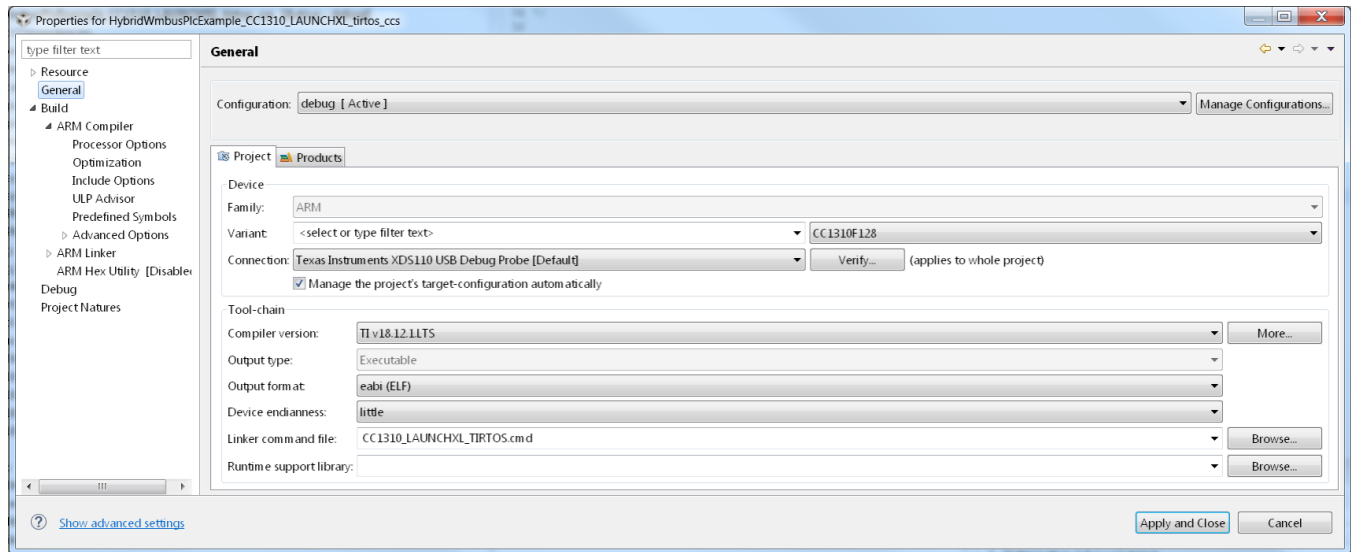
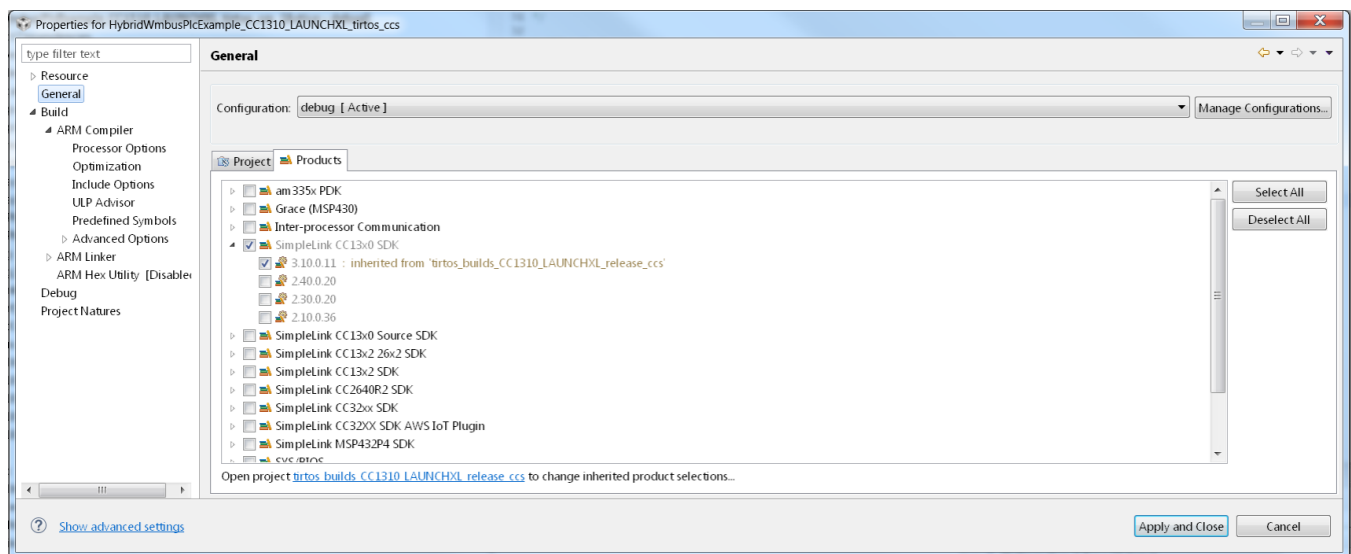
To run the software example with different PLC frequency bands of FCC or ARIB, change the following one-line code in the `init_plcHandler()` to `TONEMASK_FCC_FULL_BAND` or `TONEMASK_FCC_ARIB_54`. The TX power level and TMR configuration may also be changed in the same function.

Figure 13 shows the PLC frequency band.

图 12. PLC Frequency Band Configuration

```
plcHandle.g3ToneMaskSelection = TONEMASK_CENELEC_A_36;
```

The software example runs simultaneous transmissions (sending data to both RF and PLC channels). In addition, the RF-PLC repeater feature can be supported on top of the simultaneous transmissions by enabling `RF_PLC_REPEATER` macro definition in the software.

Figure 14 shows the overall software architecture that consists of five tasks shown in the following list:

- `uartRXTask`
- `PLCStateMachineTask`
- `RFTxTask`
- `PLCTxTask`
- `applicationTask`

图 13. Hybrid WMBUS/PLC Example Software Architecture

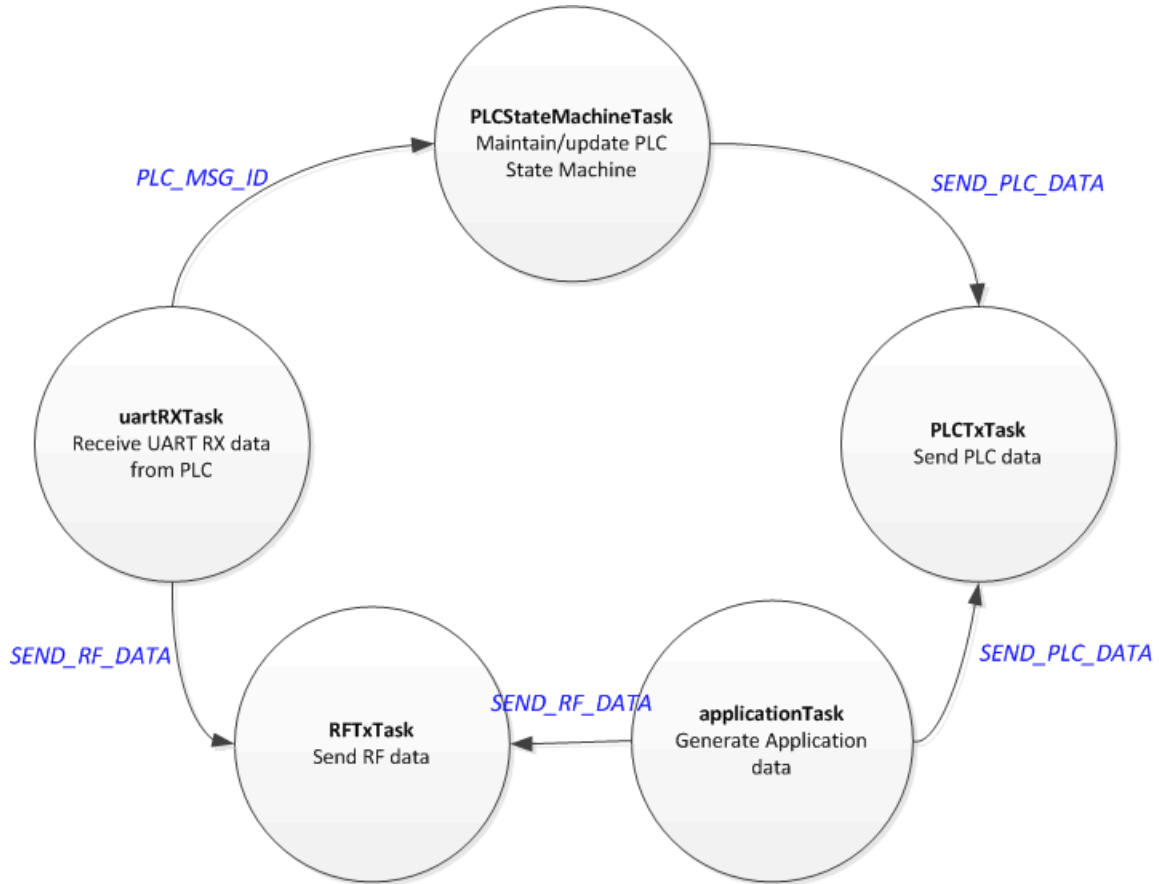

4.1.1 uARTRxTask

The uartRXTask processes PLC host messages that are received from the C2000 PLC device. The task waits for a 6-byte PLC host message header that contains a host message type, payload length, and header CRC. If the CRC passes, the task extracts the remaining bytes including payload CRC, payload sub-header, and payload. If the payload CRC passes and the message details confirmation information, then the task passes the message to the PLCStateMachineTask. If **RF_PLC_REPEATER** is enabled, and the received message contains application data, then this task passes the received data to RFTxTask.

4.1.2 PLCStateMachineTask

The PLCStateMachineTask maintains a G3-PLC service node state machine. When the power is on, the PLCStateMachine task starts to initialize G3-PLC with the default configuration and joins the G3-PLC network once the G3-PLC DC is detected. When all steps have completed, the task changes the state machine to a NORMAL state, which allows the PLCTxTask to start data transmissions.

The details of the G3-PLC host message sequences may be found in [Section 4.2](#). This example covers basic message sequences for G3-PLC operation.

4.1.3 RFTxTask

The RFTxTask waits for the mailbox message of **SEND_RF_DATA**. When the task receives the mailbox message, it constructs the application data in a wireless M-Bus packet and sends the wireless M-Bus packet to the wireless M-Bus PHY. The task then changes to the receive state. If the wireless M-Bus is working only for TX mode, the receive-related commands may be removed.

4.1.4 PLCTxTask

The PLCTxTask waits for the mailbox message of **SEND_PLC_DATA**. If the task receives the mailbox message, it sends the data over UART to the PLC C2000 device for PLC transmissions and then copies the data into PLC_HoldQueue to handle re-transmissions. When re-transmission happens, the task sends the data in the PLC_HoldQueue through UART.

4.1.5 ApplicationTask

The applicationTask emulates the application data source. This task creates 10B data, stores the data in the TX queue, and signals to both the RFTxTask and PLCTxTask for simultaneous transmissions. This event happens every five seconds with the default configuration. The application data size and interval can be configurable in application/app.c.

4.1.6 LED Configuration

The example project has two activated light-emitting diodes (LEDs) to trace software activities. The LED configuration only works for the LAUNCHXL-CC1310 EVM.

[Table 1](#) lists the LED number mapping to the specific software activity.

表 1. LED Mapping

LED NUMBER	BEHAVIOR MAPPING TO SOFTWARE ACTIVITY
DIO6	PLC TX/RX activities
DIO7	WMBus TX/RX activities

4.2 Build HYBRID-WMBUS-PLC Software Example Using CCS™

The software project can be built with CCS v9.0.1 (or above). The two project files of HybridWmbusPlcExample_CC1310_LAUNCHXL_tirtos_ccs and tirtos_builds_CC1310_LAUNCHXL_release_ccs need to be opened and the CCS project of HybridWmbusPlcExample_CC1310_LAUNCHXL_tirtos_ccs needs to be built. The screen capture of the CCS projects is shown in Figure 15. Once the compilation is successful, the binary file (HybridWmbusPlcExample_CC1310_LAUNCHXL_tirtos_ccs.out) will be generated under the directory of debug.

图 14. Build HYBRID-WMBUS-PLC CCS Project

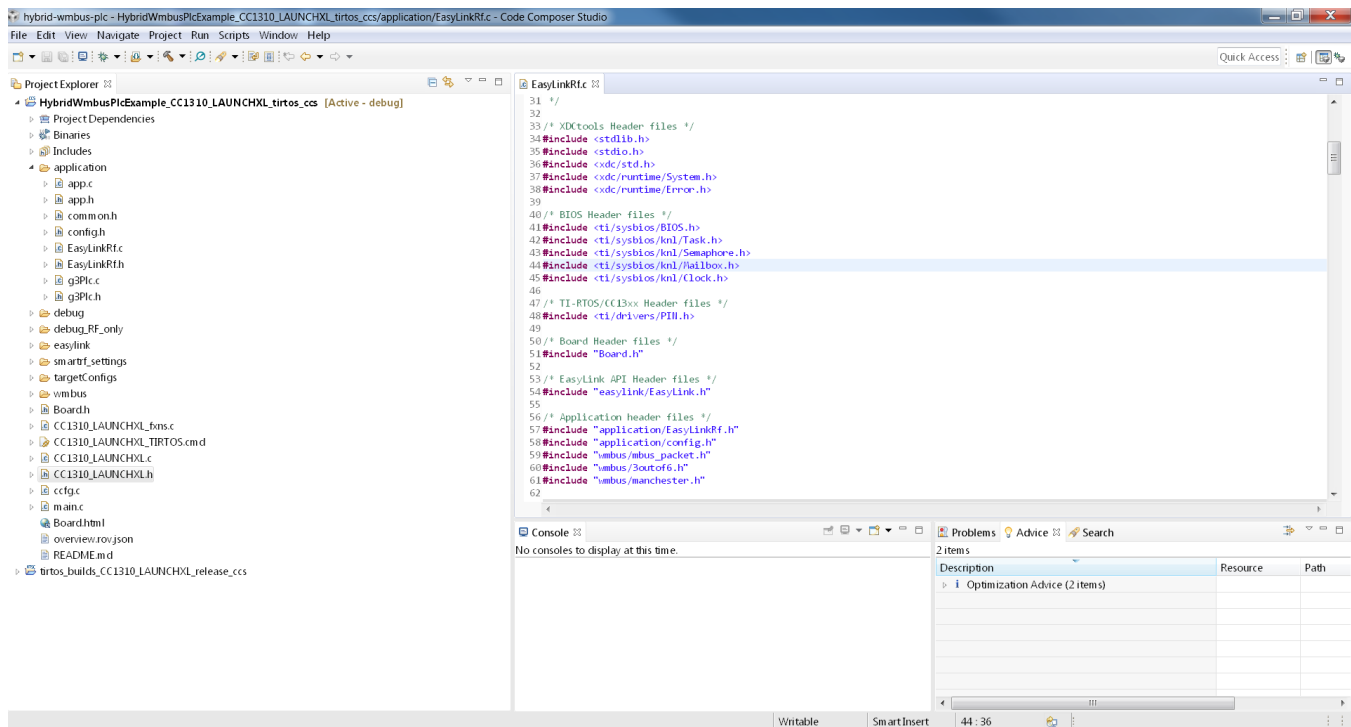

4.3 Flashing Binaries Using CCS™

This section explains the F28PLC84 (for G3-PLC) and CC1310 (for Hybrid wireless M-Bus/PLC application devices) flash software binary procedure.

4.3.1 Flashing Hybrid Wireless M-Bus/PLC Binary to CC1310 Using CCS™

This section explains how to flash the HYBRID-WMBUS-PLC software example binary on the CC1310 device using CCS. The instructions are in the following list:

1. Connect the USB cable to the LAUNCHXL-CC1310 EVM.
2. Launch the target configuration for CC1310 and connect to the device in the CCS debug mode
3. Select *Run* → *Load* → *Load Program* and flash **HybridWmbusPlcExample_CC1310_LAUNCHXL_tirtos_ccs.out** under the *debug* directory.

4.3.2 Flashing PLC Binary to TMS320F28PLC84

The step-by-step procedure may be found in Section 7.1 (with C2Prog tool) and Section 7.2 (with the CCS tool) in the *System on Module for G3 Power Line Communication (CENELEC Frequency Band)* design guide [4]. The latest G3-PLC software may be found in [TI-PLC-G3-CENELEC-SN-F28PLC84](#).

5 Hybrid Wireless M-Bus/PLC Test

The goal of the hybrid wireless M-Bus/PLC test is to prove the wireless M-Bus/PLC repeater functionality with a 3-node set up that includes one wireless M-Bus, one PLC and one hybrid wireless M-Bus/PLC node.

5.1 Test Setup

To run the Hybrid RF/PLC test, a [LAUNCHXL-CC1310](#) and [TMDSPCKITV4-CEN](#) is required. Both EVMs are available in the TI store at [TI.com](#).

[Table 2](#) lists the required tools and software to run the hybrid wireless M-Bus/PLC test.

表 2. Tools for Hybrid Wireless M-Bus/PLC Test Setup

DEVICE	EVM	HARDWARE MODIFICATION	FLASH FIRMWARE	GUI TOOL
Wireless M-Bus only	LAUNCHXL-CC1310	No	Yes ⁽¹⁾	No (Running as stand alone mode)
PLC only	TMDSPCKITV4-CEN	No	Yes (Section 4.3.2)	Yes (Zero-configuration GUI) ⁽²⁾
Hybrid wireless M-Bus with PLC	CC1310DK TMDSPCKITV4-CEN	No	Yes (节 4.3.1)	No (Running as stand alone mode)

⁽¹⁾ The pre-built wireless M-Bus standalone binary can be found in the *debug_RF_only* directory. Flashing instructions are given in [Section 4.3.1](#).

⁽²⁾ Zero-Configuration GUI is used to run PLC node as a mini-DC to start the G3-PLC network. [The G3-PLC software package](#) will install the GUI automatically.

5.2 Running Hybrid Wireless M-BUS/PLC Test

[Figure 19](#) shows a 3-node test set-up. The PLC-only node runs with the zero-configuration GUI tool. The hybrid wireless M-Bus/PLC node and wireless M-Bus echo-back node run in standalone mode.

图 15. Hybrid Wireless M-Bus/PLC Test Setup

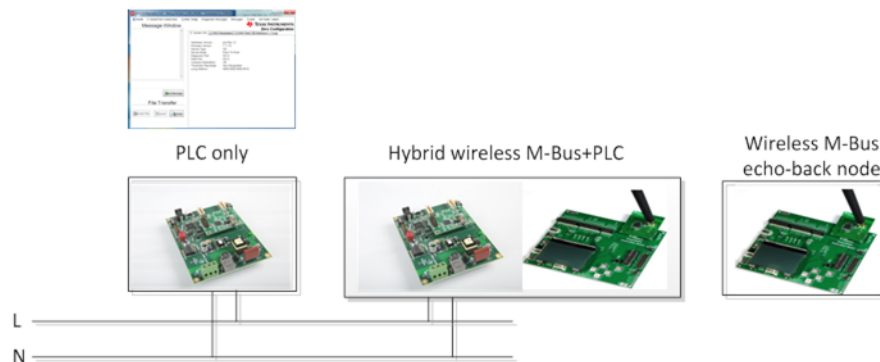

For the hybrid wireless M-Bus/PLC test, the PLC-only node is configured as G3-PLC mini-DC node. The wireless M-Bus echo-back node may run as an echo-back mode to send back the received wireless M-Bus packet to the hybrid node.

Once the power is on, the hybrid wireless M-Bus/PLC node starts to join to the PLC mini-DC (PLC only node) as the G3-PLC service node. The wireless M-Bus stacks in the hybrid node does not require a joining process. Once joined to the PLC network, the PLC-only node (running as mini-DC) may initiate echo-back data transfer.

注: To bridge echo-back data received from W-MBus node to the PLC mini-DC on the hybrid W-MBus/PLC node, the RF_PLC_REPEATER macro needs to be enabled on the hybrid node and then recompile the software example.

Figure 20 shows the details of the data flow.

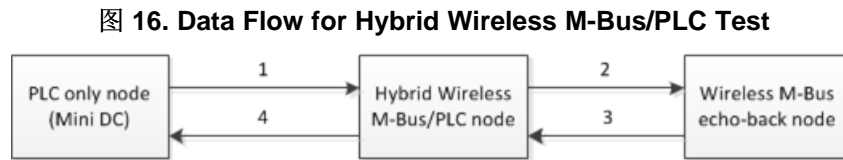

1. The PLC node sends UDP/IPv6 data through the power line.
2. The hybrid wireless M-Bus/PLC node receives the data, and passes the data to the wireless M-Bus echo-back node through the RF path.
3. The wireless M-Bus echo-back node takes the UDP/IPv6 header from the received data and then sends it back to the Hybrid wireless M-Bus/PLC node through the RF path
4. The hybrid node adds a UDP/IPv6 header on the received data because the G3-PLC only accepts IPv6 packets.
5. The hybrid node sends the data to the PLC node through the power line.

5.2.1 Test Procedure

This section covers the step-by-step procedure for running the hybrid wireless M-Bus/PLC testing.

1. Start the PLC only node as a mini-DC (Refer to Steps 1 – 4 in [Section 5.2.2](#)).
2. Turn on the Wireless M-Bus echo-back node and the hybrid wireless M-Bus/PLC node to start standalone mode
3. Start data transfer testing by clicking **Start Test** in the GUI window in the mini-DC (Refer to Step 6 in [Section 5.2.2](#)).

5.2.2 PLC Only Node Setup

This section covers how to run the PLC only node as a mini-DC with GUI.

1. Connect the PLC only node to the PC and open the intermediate GUI.
2. Set a unique long address for each device by using **Set System Config**.

图 17. Set System Configuration



图 18. G3-PLC System Configuration



3. Start a device as a mini-DC by selecting *Functions* → *Start Base Node*.

图 19. Start Base Node

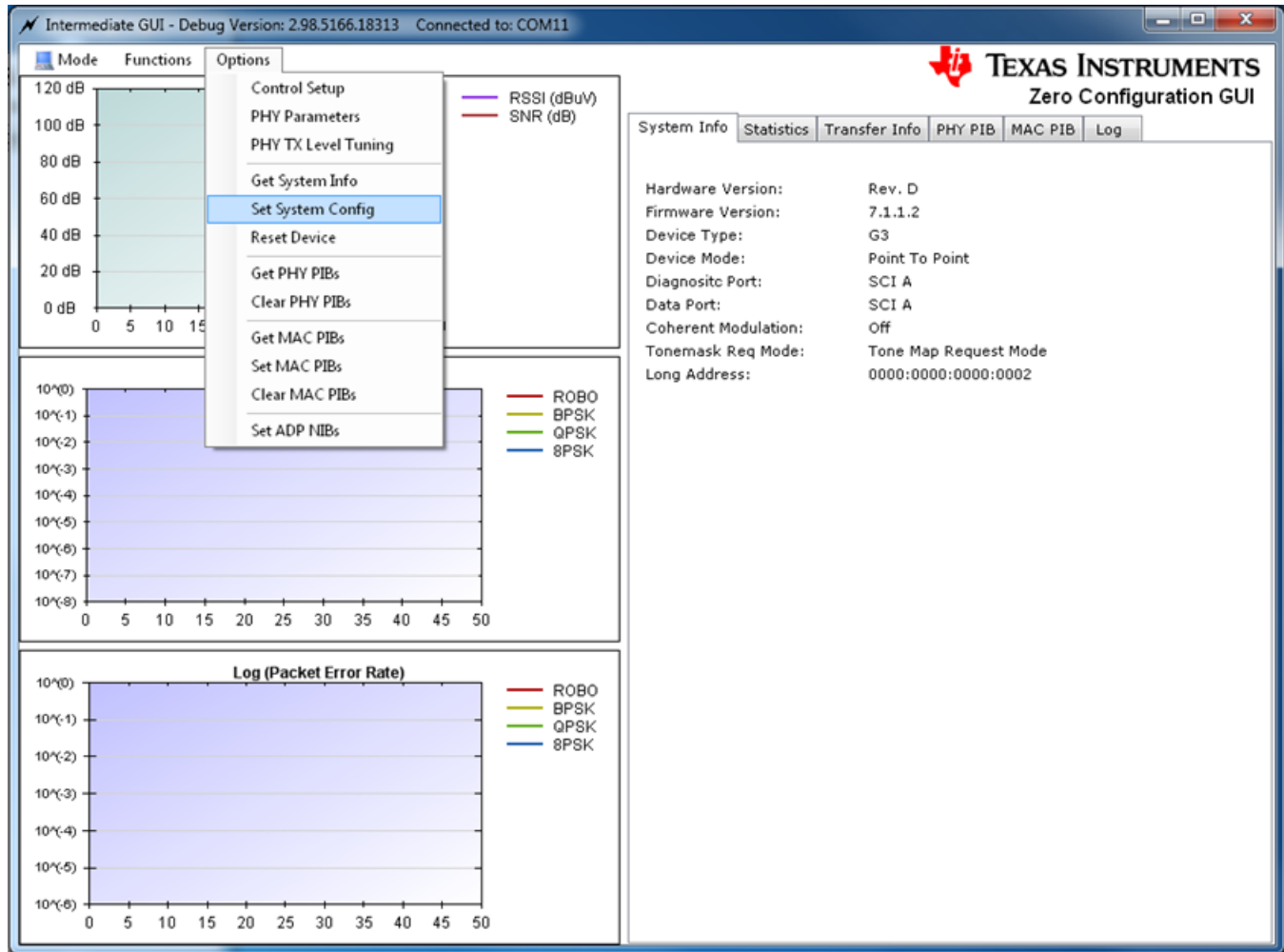
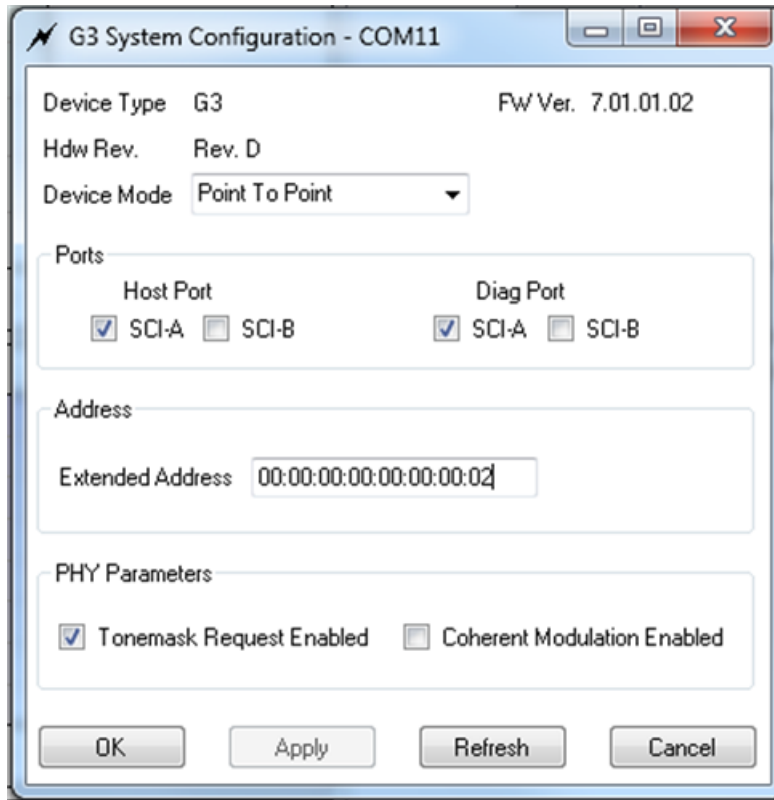
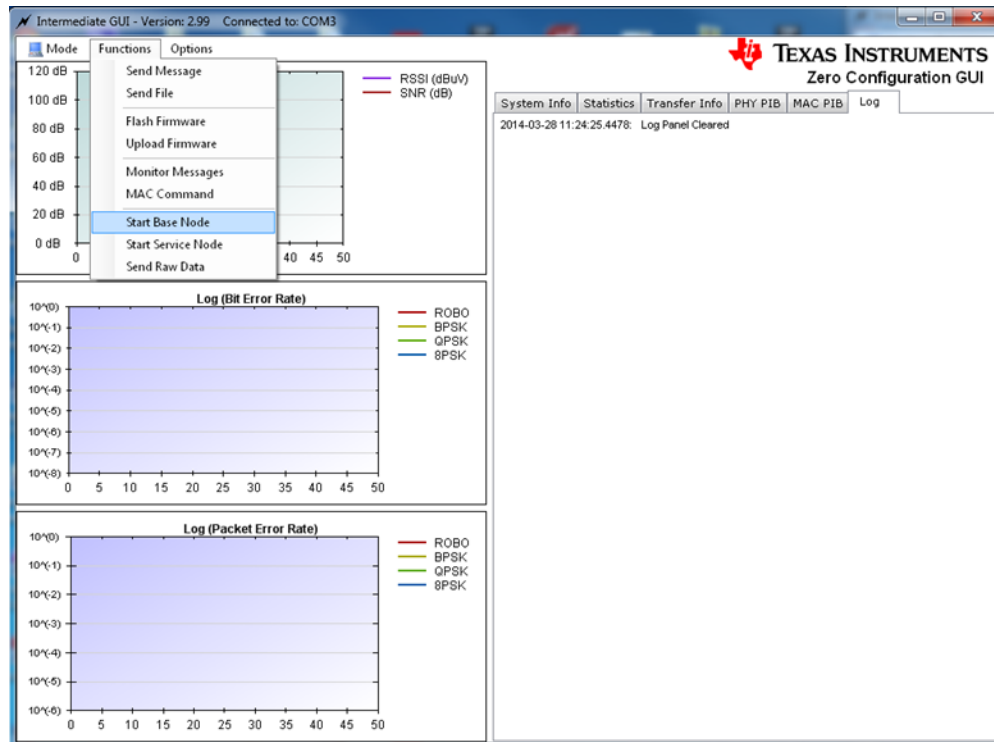

- In the pop-up window of the G3 Base Node, click **Start Network**.

图 20. G3-PLC Base Node Window

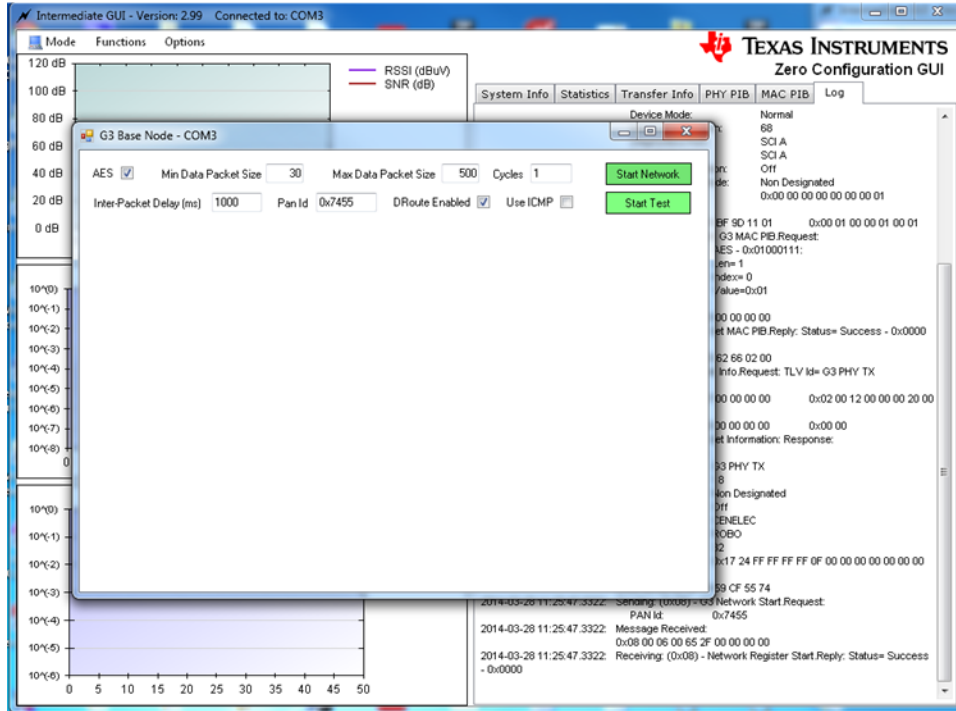

- Once the hybrid wireless M-Bus/PLC node is joined, the IPv6 information for the joined node will be available.

图 21. Joining Node Information

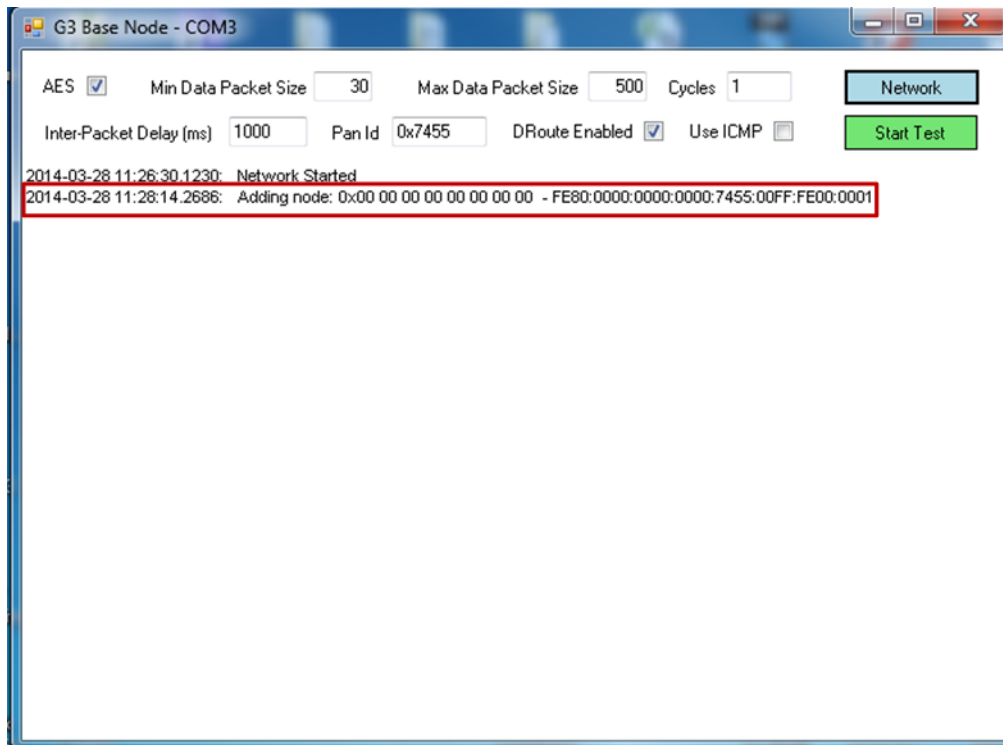

- Set the **Max Data Packet Size** to 184 due to the maximum size limitation of the wireless M-Bus specification. Then, start data echo-back testing by selecting **Start Test**.

图 22. Start Data Echo-Back Test

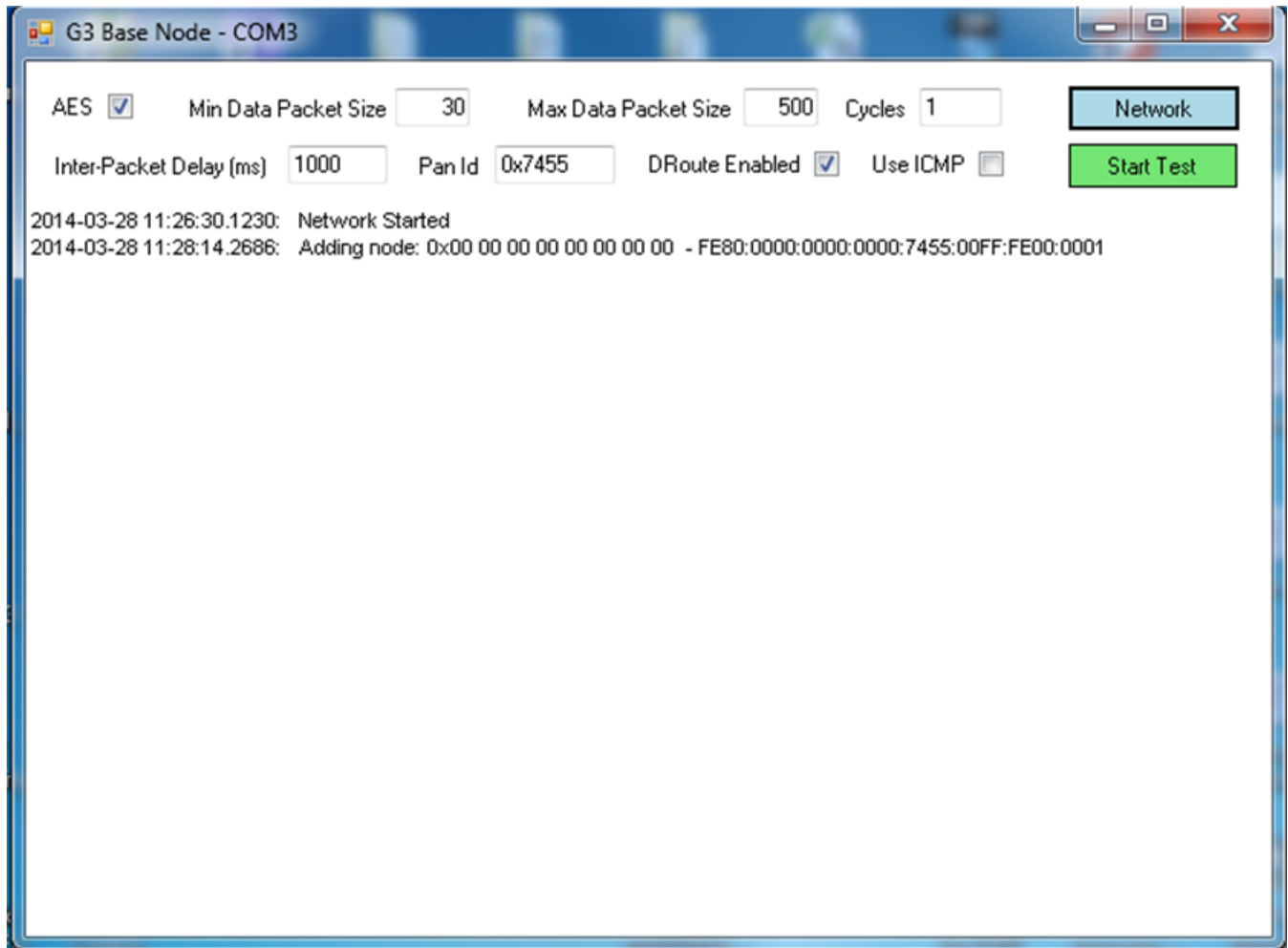

5.3 Hybrid Wireless M-Bus/PLC Test Results

This section shows the hybrid wireless M-Bus/PLC test results to verify wireless M-Bus/PLC repeater functionality.

Figure 27 shows the echo-back test results. For the testing, mini-DC configures minimum packet size to 6B, maximum packet size to 184B, test cycles to 1000 cycles, and the packet interval to 2000 msec. The packet size increases by 1B every transmission. As shown in the result, all the data is successfully echo-backed through the RF and PLC mixed paths, which proves that the hybrid wireless M-Bus/PLC routes the PLC and wireless M-Bus packets between the PLC only and wireless M-Bus only nodes.

图 23. Hybrid Wireless M-Bus and PLC Echo-Back Test Result

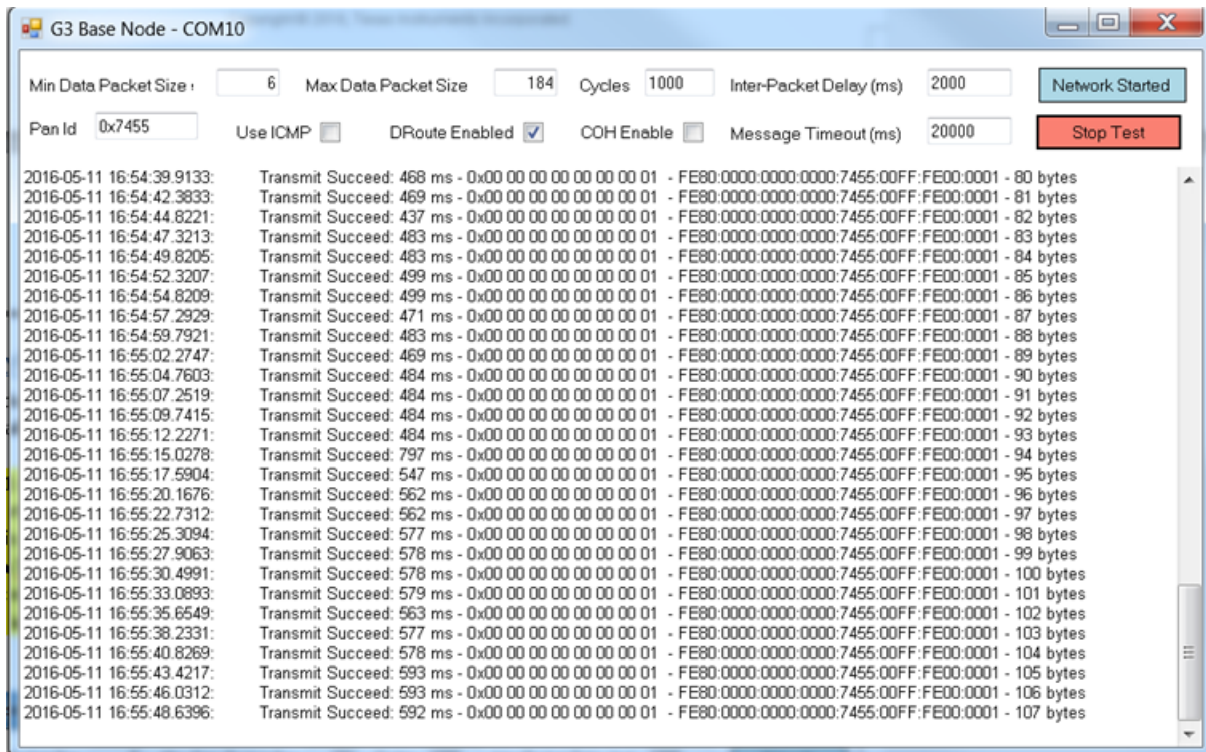

6 Design Files

6.1 Schematics

To download the schematics, refer to the [TIDC-HYBRID-WMBUS-PLC](#) design files.

6.2 Bill of Materials

To download the bill of materials (BOM), refer to the [TIDC-HYBRID-WMBUS-PLC](#) design files.

6.3 Layout Prints

To download the layout prints for each board, refer to the [TIDC-HYBRID-WMBUS-PLC](#) design files.

6.4 Gerber Files

To download the Gerber files, refer to the [TIDC-HYBRID-WMBUS-PLC](#) design files.

6.5 Assembly Drawings

To download the assembly drawings, refer to the [TIDC-HYBRID-WMBUS-PLC](#) design files.

7 Software Files

To download the software files, refer to the [TIDC-HYBRID-WMBUS-PLC](#) design files.

8 Related Documentation

1. Texas Instruments, *CC1310 SimpleLink™ Ultralow Power Sub-1-GHz Wireless MCU*, CC1310 Datasheet, [SWRS181](#)
2. Texas Instruments, *MS320F28PLC8x Power Line Communications (PLC) Processors*, TMS320F28PLC83/4 Datasheet, [SPRS802](#)
3. Texas Instruments, *Powerline Communications Analog Front-End*, TMS320F28PLC83/4 Datasheet, [SBOS531](#)
4. Texas Instruments, *System on Module for G3 Power Line Communication (CENELEC Frequency Band)*, TIDM-SOMPLC-G3-CENELEC Design Guide, [TIDU442](#)
5. Texas Instruments, *Hybrid RF and PLC Reference Design to Extend Network Coverage and Reliability*, TIDC-HYBRID-RF-PLC Design Guide, [TIDUBM3](#)

8.1 商标

E2E is a trademark of Texas Instruments.

9 Terminology

1. **PLC**: Power-line communication
2. **RF**: Radio frequency
3. **TMR**: Tone map request
4. **DC**: Data concentrator
5. **VCU**: Viterbi/complex math unit
6. **AMI**: Advanced metering infrastructure
7. **AFE**: Analog front end

10 About the Author

WONSOO KIM is a system engineer at Texas Instruments, where he is responsible for driving system solutions for Smart Grid applications, defining future requirements in the TI product roadmap, and providing system-level support and training focused on communication software and systems for Smart Grid customers. He received his Ph.D. in Electrical and Computer Engineering from the University of Texas at Austin in Austin, TX.

修订历史记录

注：之前版本的页码可能与当前版本有所不同。

Changes from Original (June 2016) to A Revision	Page
• 已更改 将 LAUNCHXL-CC1310DK 更改为 LAUNCHXL-CC1310.....	1
• 已更改 将 TX/RX 更改为 TRX	1
• 已更改 LAUNCHXLCC1310DK TO LAUNCHXLCC1310	8
• 已更改 CC1310DK to LAUNCHXL-CC1310	8
• 已更改 CC1310DK to LAUNCHXL-CC1310	8
• 已更改 CC1310DK to LAUNCHXL-CC1310	9
• 已更改 text from and shows UART pins connections between TMDSPCKITV4 and CC1310DK to shows UART pin on the TMDSPCKITV4 connected to the LAUNCHXL-CC1310.	9
• 已更改 EM-UART_RX in P412 shown in the CC1310DK docking board to UART_RX pin (DIO 2) on the LAUNCHXL-CC1310.....	9
• 已更改 EM-UART_RX to UART_TX pin (DIO 3) on the LAUNCHXL-CC1310.....	9
• 已更改 one of the GND pins to The GND pin	9
• 已更改 GND in P412 () to GND pin on the LAUNCHXL-CC1310.....	9
• 已更改 software example (TI_Hybrid_WMBUS_PLC_example) to HYBRID-WMBUS-PLC software example	11
• 已添加 paragraph	11
• 已添加 Figure 10 and 11	11
• 已更改 title from Hybrid_WMBUS_PLC_Project to TIDC-HYBRID-WMBUS-PLC Software example. Changed paragraph text.	12
• 已更改 paragraph text.....	12
• 已更改 paragraph text.....	12
• 已更改 paragraph text.....	14
• 已更改 paragraph text.....	14
• 已更改 four to two.....	14
• 已更改 CC1310DK to LAUNCHXL-CC-1310.....	14
• 已更改 title and paragraph.....	15
• 已更改 title from Hybrid_WMBUS_PLC to HYBRID-WMBUS-LC CCS	15
• 已更改 hybrid wireless M Bus/PLC to HYBRID-WMBUS-PLC software	15
• 已更改 CC1310DK to LAUNCHXL-CC1310 EVM	15
• 已更改 paragraph text.....	15
• 已更改 paragraph text.....	15
• 已更改 paragraph text.....	16
• 已更改 CC1310DK to LAUNCHXL-CC1310.....	16
• 已添加 with.....	16
• 已删除 (and)	16
• 已更改 paragraph text.....	16
• 已删除 paragraph text.....	16
• 已添加 paragraph text.....	17
• 已添加 and deleted text	17

重要声明和免责声明

TI“按原样”提供技术和可靠性数据（包括数据表）、设计资源（包括参考设计）、应用或其他设计建议、网络工具、安全信息和其他资源，不保证没有瑕疵且不做任何明示或暗示的担保，包括但不限于对适销性、某特定用途方面的适用性或不侵犯任何第三方知识产权的暗示担保。

这些资源可供使用 TI 产品进行设计的熟练开发人员使用。您将自行承担以下全部责任：(1) 针对您的应用选择合适的 TI 产品，(2) 设计、验证并测试您的应用，(3) 确保您的应用满足相应标准以及任何其他功能安全、信息安全、监管或其他要求。

这些资源如有变更，恕不另行通知。TI 授权您仅可将这些资源用于研发本资源所述的 TI 产品的应用。严禁对这些资源进行其他复制或展示。您无权使用任何其他 TI 知识产权或任何第三方知识产权。您应全额赔偿因在这些资源的使用中对 TI 及其代表造成的任何索赔、损害、成本、损失和债务，TI 对此概不负责。

TI 提供的产品受 [TI 的销售条款](#) 或 [ti.com](#) 上其他适用条款/TI 产品随附的其他适用条款的约束。TI 提供这些资源并不会扩展或以其他方式更改 TI 针对 TI 产品发布的适用的担保或担保免责声明。

TI 反对并拒绝您可能提出的任何其他或不同的条款。

邮寄地址：Texas Instruments, Post Office Box 655303, Dallas, Texas 75265

Copyright © 2022，德州仪器 (TI) 公司