

# EVM User's Guide: LM34938Q1EVM-HD

## LM34938-Q1 降压/升压控制器评估模块



### 说明

**LM34938Q1EVM-HD** 演示了一款采用 **LM34938-Q1** 的高功率灵活降压/升压设计。该评估模块经配置，可在 **9V 至 36V** 的输入电压范围内运行，并提供 **15V 至 28V** 稳压输出，输出功率高达 **50W**。该 EVM 的工作开关频率为 **2.1MHz**。该器件的大多数设置可通过跳线轻松调整或设置，例如：工作模式（**PSM** 或 **fPWM**）、辅助电源和外部时钟同步。

### 开始使用

1. 将 EVM 连接到电源和负载。
2. 使用 **USB2ANY** 适配器配置 GUI 和 I2C 操作。
3. 安装 LM34938-Q1 配置 GUI。

### 特性

- 宽输入电压范围
- 超高 (> 95%) 峰值电源转换效率
- 可使用反馈电阻或 I2C 接口来调节输出电压
- 可选同步 (SYNC)
- 可轻松配置电流监控器或限制器
- 支持电缆压降补偿
- 输出断开支持
- 可编程输入欠压锁定 (UVLO) 阈值和迟滞
- 输出恒压 (CV) 和恒流 (CC) 选项
- 具有 USB2ANY 和 GUI 的 I2C 接口
- 通过 DIP 开关设置配置电阻器  $R_{CFG2}$

### 应用

- 汽车信息娱乐、数字驾驶舱
- 无线充电

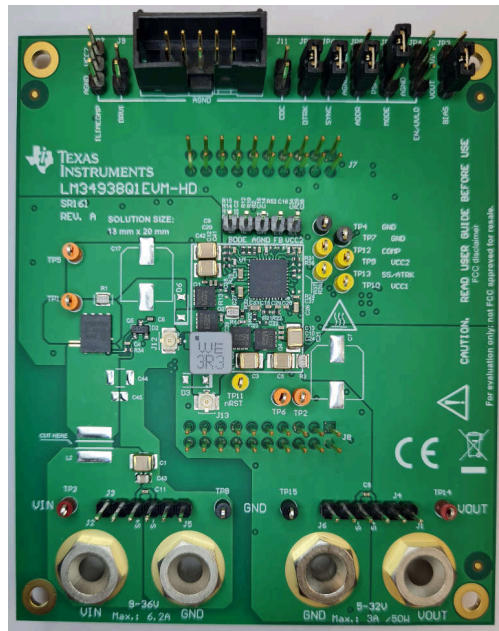

## 1 评估模块概述

### 1.1 简介

**LM34938Q1EVM-HD** 评估模块 (EVM) 旨在方便地评估 **LM34938-Q1** 宽 VIN 降压/升压控制器的性能。LM34938-Q1 是一款宽  $V_{IN}$  四开关降压/升压控制器。无论输入电压是高于、等于还是低于调节后的输出电压，该器件均可提供稳定的输出电压。在省电模式下，该器件支持在整个输出范围内实现出色的效率。

通过可选使用 I2C 接口，该器件涵盖了用于配置和调整开关模式电源运行的附加参数。

为了检查性能，I2C 接口还便于轻松测量降压/升压控制器的典型信号。

### 1.2 套件内容

- 一个 LM34938Q1EVM-HD PCB
- EVM 免责声明自述文件

### 未包含的内容

该 EVM 不包含 USB2ANY 接口。

如需订购 USB2ANY 接口适配器，请访问 [USB2ANY 接口适配器页面](#)。

### 1.3 规格

表 1-1. 评估板规格

参数	值
输入电压	9.0V 至 36V
输出电压	5V 至 32V
最大输出电流	3A
默认开关频率	2.1MHz
电路板尺寸 ( 四层 )	4.1inch × 3.6inch

### 1.4 器件信息

LM34938-Q1 是一款四开关降压/升压控制器。无论输入电压是高于、等于还是低于调节后的输出电压，该器件均可提供稳定的输出电压。在省电模式下，该器件支持在整个输出范围内实现出色的效率。

- 宽输入电压范围：3.5V 至 36V
- 输出电压范围为 3.3V 至 48V
- 峰值电流调节方案
- 输出电压动态跟踪
  - 数字 PWM 跟踪输入
  - 模拟跟踪输入
  - 通过 I2C 接口编程
- 最小静态电流
  - 3  $\mu$ A 的低关断 IQ
  - 25  $\mu$ A 的低工作 IQ
- 可实现高轻负载效率的运行模式选择
  - 省电突发模式
  - $\mu$  Sleep 省电模式
- 集成高压电源 LDO

## 2 硬件连接器、测试点和选择开关说明

本节提供了 EVM 的 I/O 连接器、跳线和测试点。

电源必须连接到输入连接器 J2 和 J5。

负载必须连接到输出连接器 J1 和 J6。

### 2.1 连接器说明

表 2-1. 连接器

参考指示符	说明
J1	输出电压正连接
J2	输入电压正连接
J3	输入电压正和输入电压返回测试点
J4	输出电压正和输出电压返回测试点
J5	输入电压回路连接
J6	输出电压回路连接
J7	Launchpad 连接器
J8	Launchpad 连接器
J9	DRV1 输出连接
J10	I2C/USB2ANY 连接器
J11	CDC 输出连接
J12	SW1 的 MHFI 连接器
J13	SW2 的 MHFI 连接器

表 2-2. Launchpad 连接器 : J7/J8

引脚	功能	引脚	功能
1	CDC : 电流监测信号	2	PTC : 温度传感器
3	PDCTRL_GOOD : 温度传感器电源	4	nFLT 信号
5	EN/UVLO 信号	6	I2C : SDA
7	GND	8	I2C : SCL
9	VCC1 ( 通过跳线 JP12 连接 )	10	GND

### 2.2 跳线说明

表 2-3. 跳线

参考指示符	引脚	说明	默认连接
JP1	引脚 1 至引脚 2	将 DTRK 设置为 GND	*
JP2	引脚 1 至引脚 3	使用外部分压器电路时，可用于波特图信号注入	
	引脚 4 至引脚 5 (FB)	将 FB 连接到 VCC2 ( 如果未组装 R2 ) 以使用内部分压器电路	
JP3	引脚 1 至引脚 2 (VOUT1)	Connect 偏置到 VOUT ( 功率级输出 )	*
	引脚 2 至引脚 3 (VIN)	Connect 偏置到 VIN ( 断开开关后 )	

**表 2-3. 跳线 (续)**

参考指示符	引脚	说明	默认连接
JP4	引脚 1 至引脚 2 (GND)	Connect EN/UVLO 至 GND	
	引脚 2 至引脚 3 (VIN)	Connect EN/UVLO 至 VIN	
JP5	引脚 1 至引脚 2 (GND)	将 MODE 设置为低电平: PSM 模式	
	引脚 2 至引脚 3 (VCC2)	将 MODE 设置为高电平: FPWM 模式	*
JP6	引脚 1 至引脚 2 (SYNC)	将 SYNC 设置为 GND	*
JP7	引脚 1 至引脚 2 (GND)	将 ILIMCOMP 连接到 GND	
	引脚 2 至引脚 3 (VCC2)	将 ILIMCOMP 连接到 VCC2 (禁用电流限制器)	
	开路	启用电流限制器功能	
JP8	引脚 1 至引脚 2 (ADDR/AGND)	将 I2C 地址设置为 0x6A	*
	引脚 2 至引脚 3 (ADDR/VCC2)	将 I2C 地址设置为 0x6B	

## 2.3 测试点说明

**表 2-4. 测试点**

参考指示符	说明
TP1	ISNSP 测试点 (输入侧)
TP2	ISNSN 测试点 (输入侧)
TP3 (VIN)	输入电压正测试点
TP4	AGND 测试点
TP5	ISNSP 测试点 (输出侧)
TP6	ISNSN 测试点 (输出侧)
TP7	AGND 测试点
TP8 (GND)	输入电压返回测试点
TP9	VCC2 测试点
TP10	VCC1 测试点
TP11	nRST 测试点
TP12	COMP 测试点
TP13	SS/ATRK 测试点
TP14 (VOUT)	输出电压正测试点
TP15 (GND)	输出电压返回测试点

### 3 实现结果

#### 3.1 测试设置

图 3-1 展示了用于评估 LM34938Q1EVM-HD 的典型测试设置。



图 3-1. 典型的 EVM 连接图

#### 3.2 测试程序

1. 将电源电流限值设置为 10A。
2. 关闭电源。
3. 将电源的正输出连接到 J2，负输出连接到 J5。
4. 将负载连接到 J1 实现正连接，连接到 J6 实现负连接。
5. 将电源电压设置为 12V，将电子负载设置为 0.1A。
6. 通过 GUI 启用器件
7. 确保电子负载电压通过标称 5V 输出进行调节。
8. 缓慢增大负载，同时监控 J4-VOUT 和 J4-GND 之间的输出电压。当输出负载增加到 3A 时，输出电压必须保持标称 5V 输出的稳压。
9. 从 12V 至 36V 缓慢扫描输入电压。输出电压必须通过标称 5V 输出进行调节。
10. 通过 I2C 和 GUI 将输出电压设置为 32V
11. 将负载降至 1.8A。
12. 从 36V 至 12V 缓慢扫描输入电压。确保输出电压必须通过标称 32V 输出进行调节。

13. 将输入电压降至 0V 以关闭降压/升压转换器，然后关闭负载。

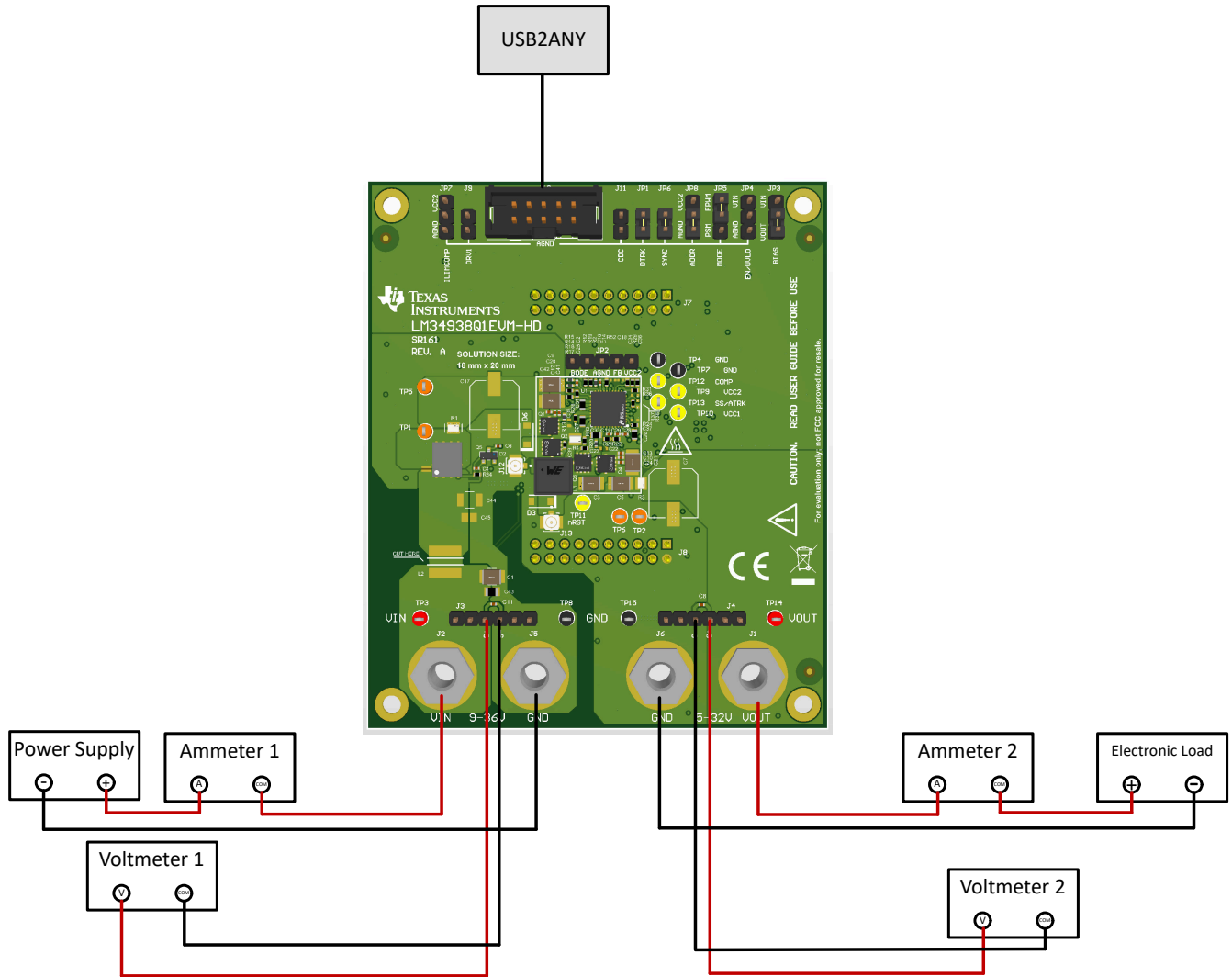
### 3.3 注意事项



小心

在全功率低输入下长时间运行会导致 FET ( Q1 至 Q8 ) 发热。电路板表面会变热。请勿触摸。接触会导致烫伤。

### 3.4 测试数据和性能曲线

#### 3.4.1 热性能



图 3-2. 热像图 :  $V_{IN} = 20.0V$  ,  $V_{OUT} = 5.0V$  ,  $I_{OUT} = 3.0A$  , 无强制空气冷却



图 3-3. 热像图 :  $V_{IN} = 20.0V$  ,  $V_{OUT} = 28.0V$  ,  $I_{OUT} = 1.8A$  , 无强制空气冷却

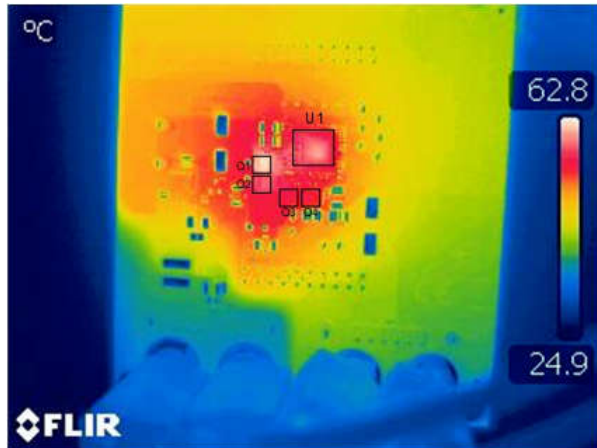

图 3-4. 热像图 :  $V_{IN} = 20.0V$  ,  $V_{OUT} = 28.0V$  ,  $I_{OUT} = 3.0A$  , 无强制空气冷却

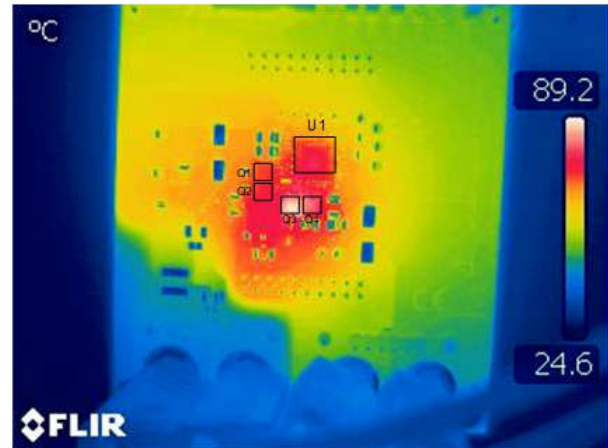

图 3-5. 热像图 :  $V_{IN} = 38.0V$  ,  $V_{OUT} = 28.0V$  ,  $I_{OUT} = 3.0A$  , 无强制空气冷却

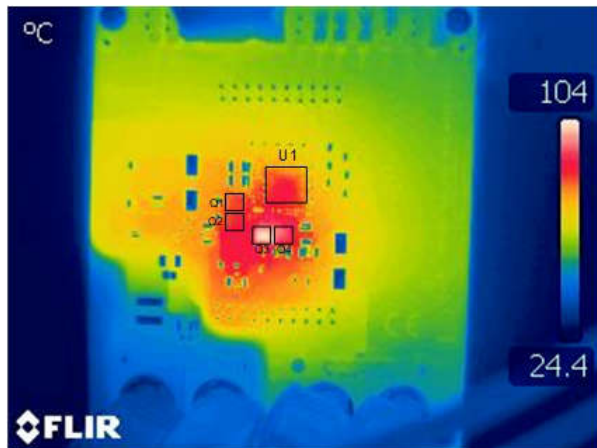

图 3-6. 热像图 :  $V_{IN} = 9.0V$  ,  $V_{OUT} = 28.0V$  ,  $I_{OUT} = 1.8A$  , 无强制空气冷却

### 3.4.2 效率

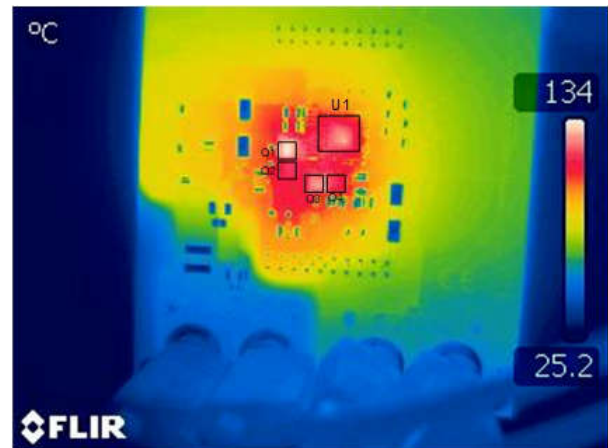

图 3-7. 效率与输出电流间的关系曲线 ( $V_{IN} = 12V$  时)

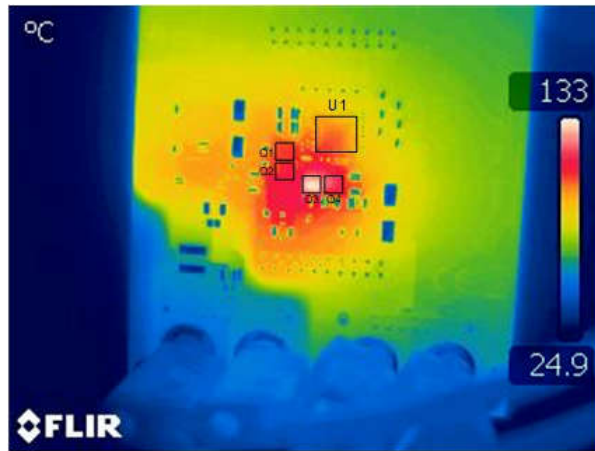

图 3-8. 效率与输出电流间的关系曲线 ( $V_{IN} = 20V$  时)

### 3.4.3 稳态波形

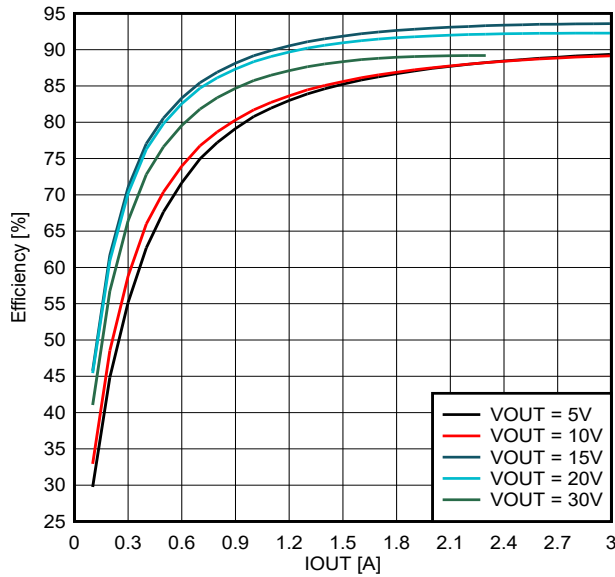

图 3-9. SW1、SW2、 $I_L$  ( $V_{IN} = 12V$ ,  $V_{OUT} = 5V$ ,  $I_{OUT} = 3A$ )

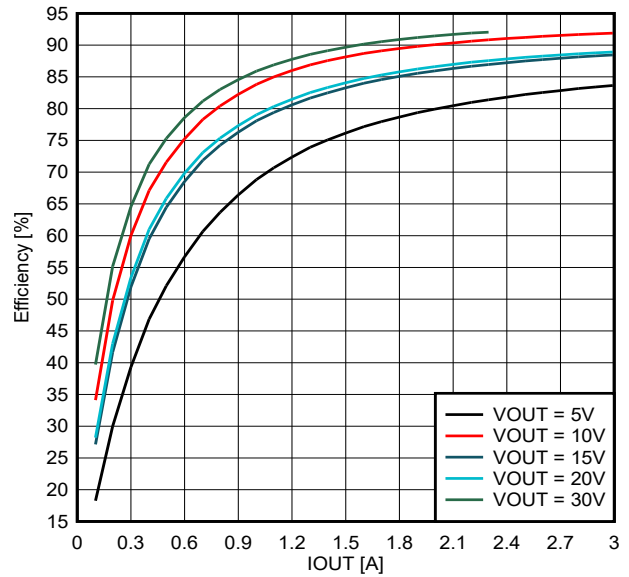

图 3-10. SW1、SW2、 $I_L$  ( $V_{IN} = 12V$ ,  $V_{OUT} = 12V$ ,  $I_{OUT} = 3A$ )

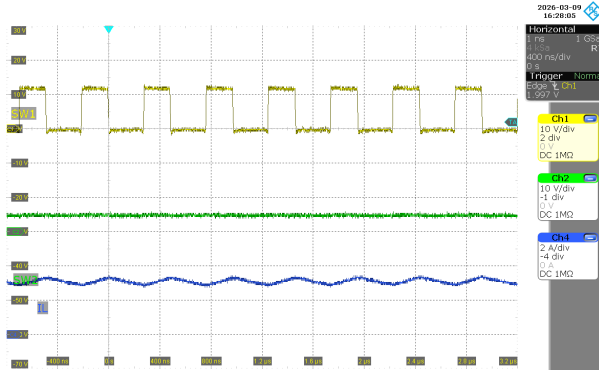

图 3-11. SW1、SW2、 $I_L$  ( $V_{IN} = 12V$ ,  $V_{OUT} = 28V$ ,  $I_{OUT} = 1.8A$ )

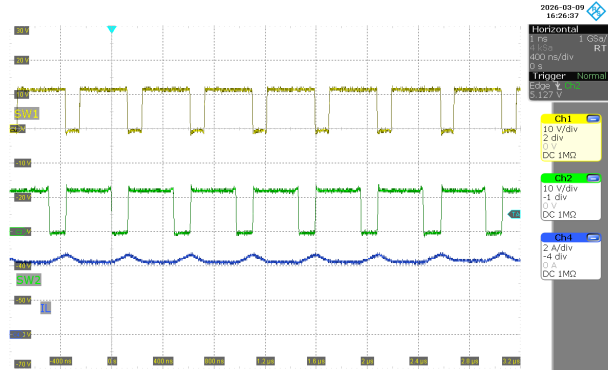

图 3-12. SW1、SW2、 $I_L$  ( $V_{IN} = 20V$ ,  $V_{OUT} = 5V$ ,  $I_{OUT} = 3A$ )

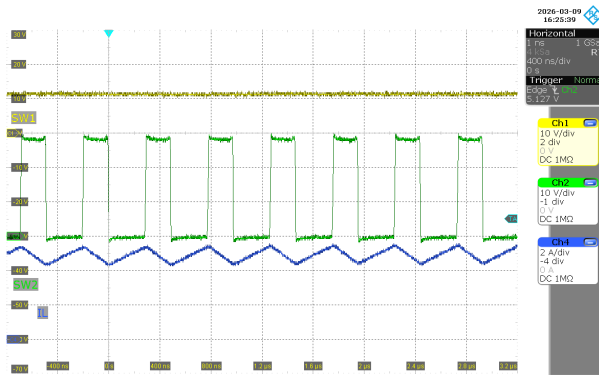

图 3-13. SW1、SW2、 $I_L$  ( $V_{IN} = 20V$ ,  $V_{OUT} = 20V$ ,  $I_{OUT} = 3A$ )

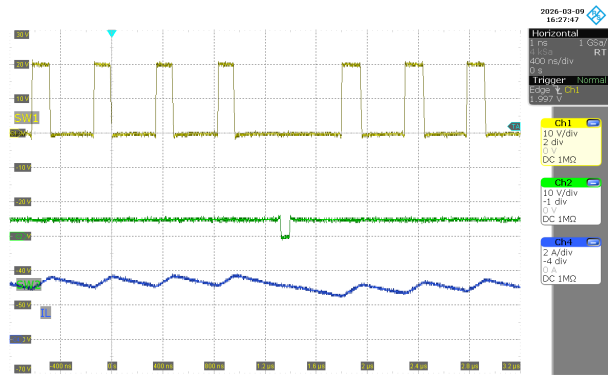

图 3-14. SW1、SW2、 $I_L$  ( $V_{IN} = 20V$ ,  $V_{OUT} = 28V$ ,  $I_{OUT} = 3A$ )

### 3.4.4 阶跃负载响应

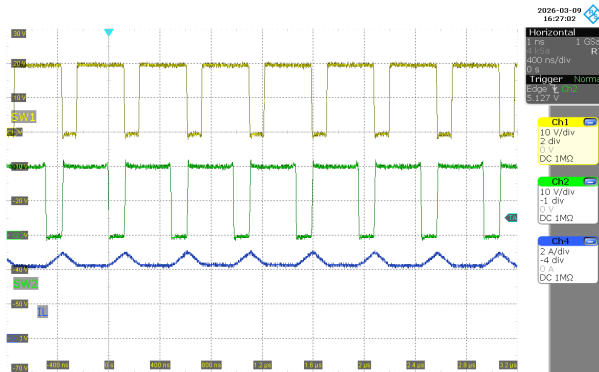

图 3-15. 负载阶跃 ( $V_{IN} = 12V$ ,  $V_{OUT} = 5V$ ,  $I_{OUT} = 0.5A - 3A$ )

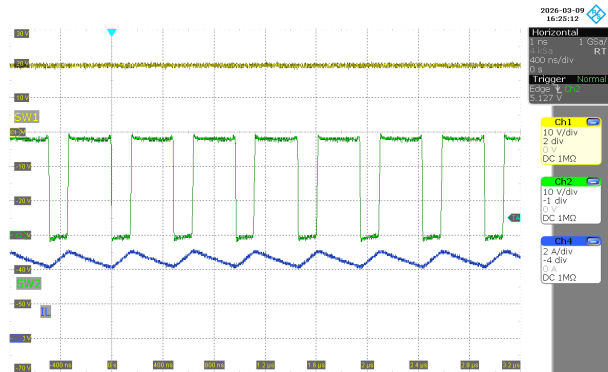

图 3-16. 负载阶跃 ( $V_{IN} = 12V$ ,  $V_{OUT} = 28V$ ,  $I_{OUT} = 0.8A - 1.8A$ )

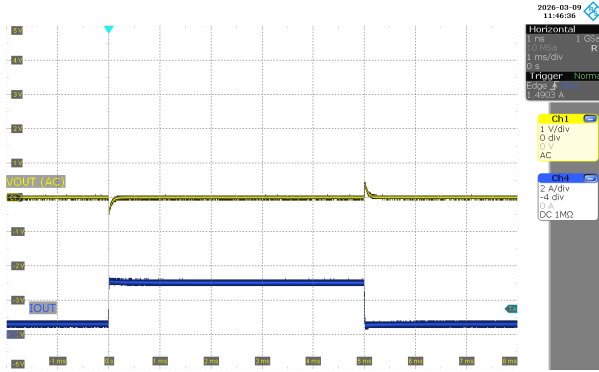

图 3-17. 负载阶跃 ( $V_{IN} = 20V$ ,  $V_{OUT} = 5V$ ,  $I_{OUT} = 0.8A - 3A$ )

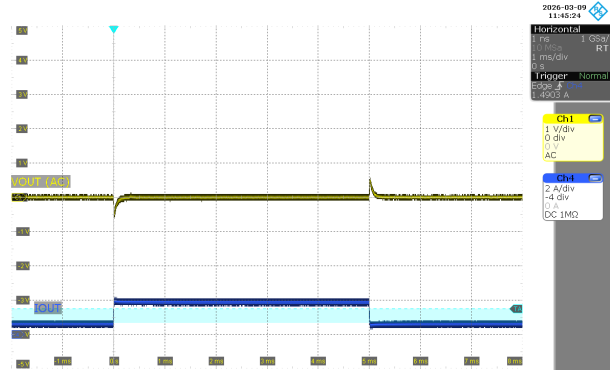

图 3-18. 负载阶跃 ( $V_{IN} = 20V$ ,  $V_{OUT} = 28V$ ,  $I_{OUT} = 0.8A - 3A$ )

### 3.4.5 交流环路响应曲线

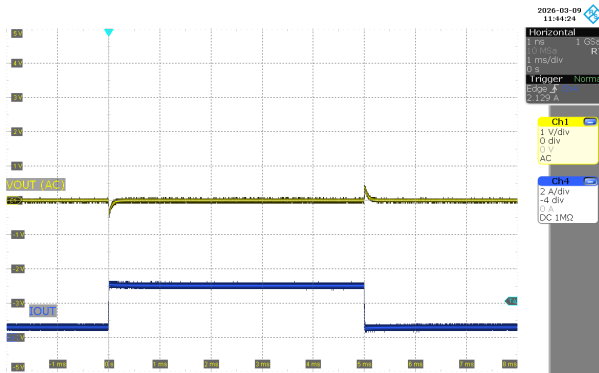

图 3-19. 控制环路响应,  $V_{IN} = 12V$ ,  $V_{OUT} = 5V$ ,  $I_{OUT} = 3.0A$

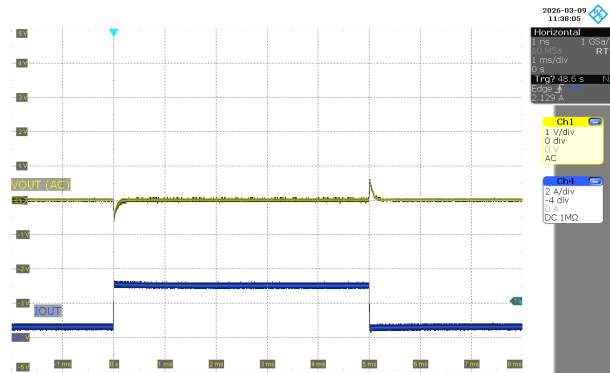

图 3-20. 控制环路响应,  $V_{IN} = 12V$ ,  $V_{OUT} = 28V$ ,  $I_{OUT} = 1.8A$

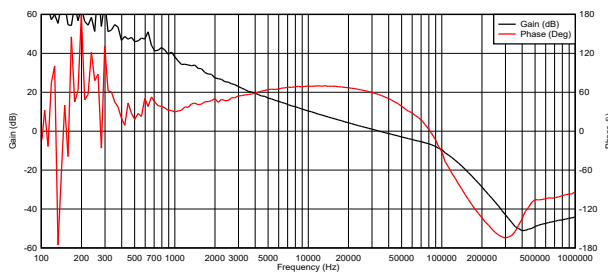

图 3-21. 控制环路响应,  $V_{IN} = 20V$ ,  $V_{OUT} = 5V$ ,  $I_{OUT} = 3A$

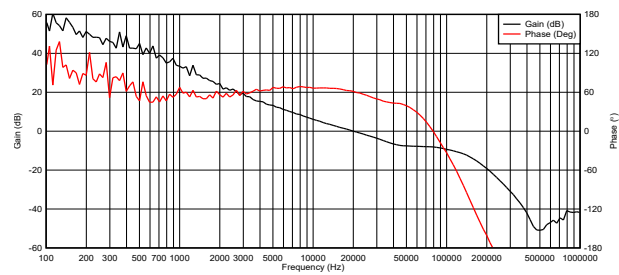

图 3-22. 控制环路响应,  $V_{IN} = 20V$ ,  $V_{OUT} = 28V$ ,  $I_{OUT} = 1.8A$

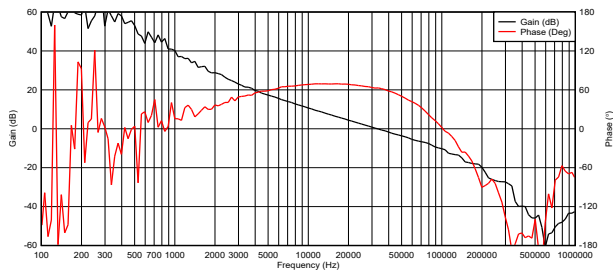

## 4.2 电路板布局

图 4-2 至 图 4-9 展示了 LM34938Q1EVM-HD PCB 设计。

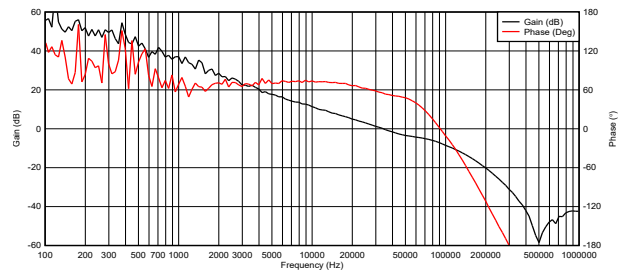

图 4-2. 顶部丝印

图 4-3. 底部丝印



图 4-4. 顶层

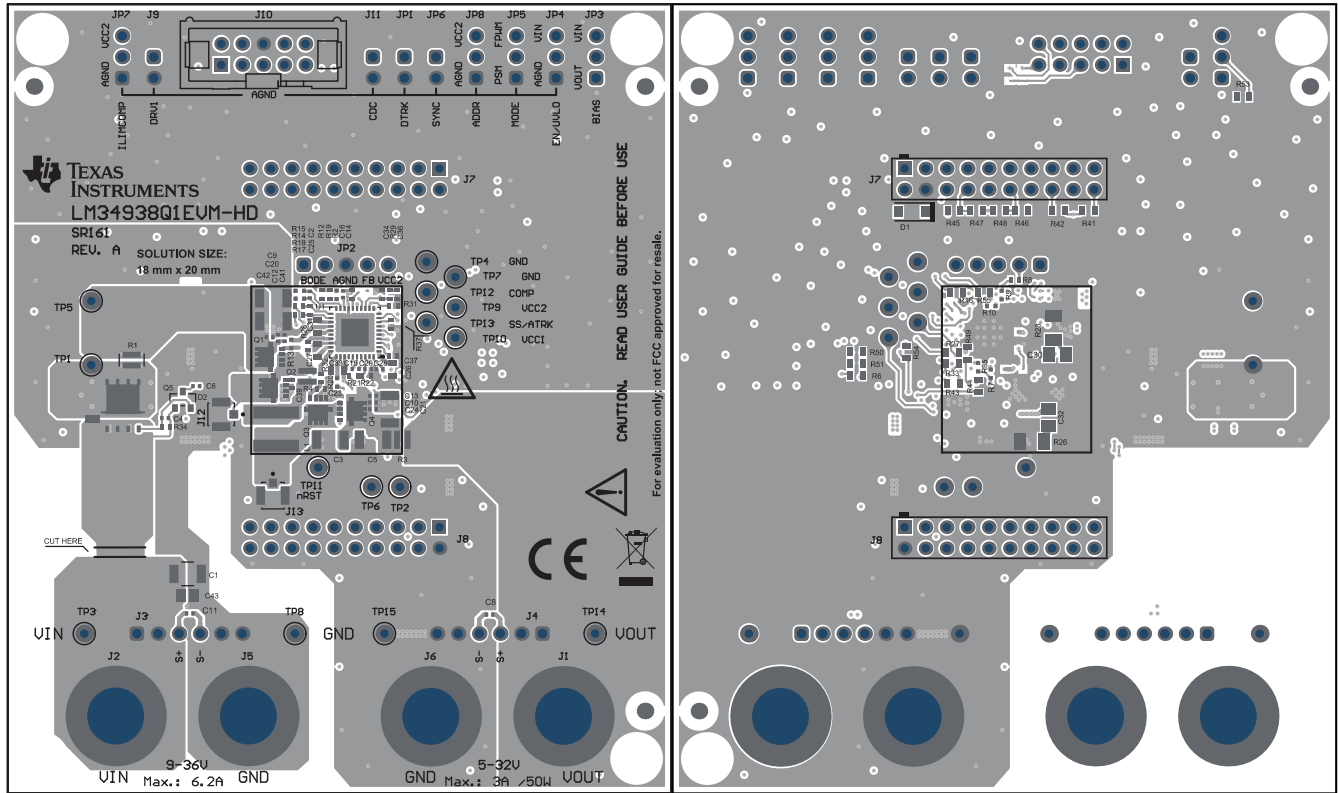

图 4-5. 中间层 1

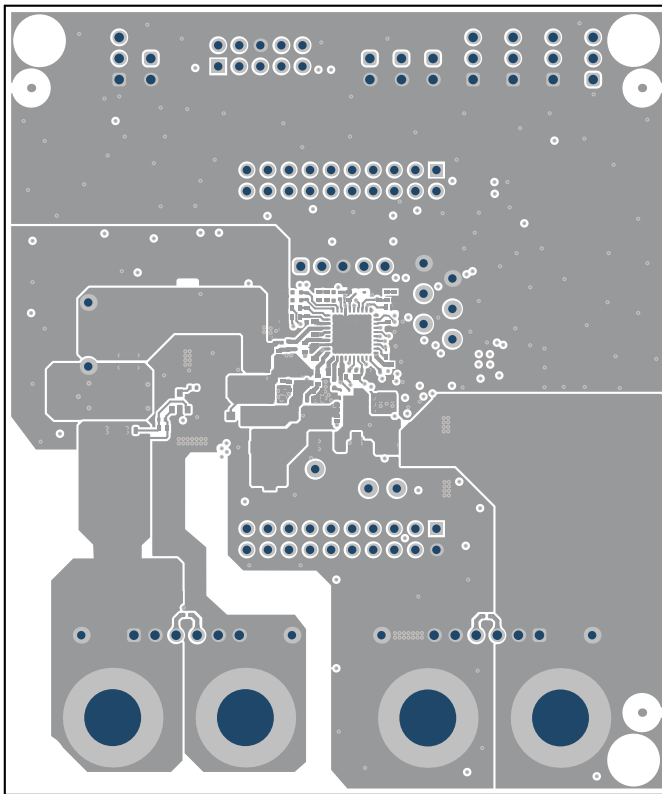

图 4-6. 中间层 2

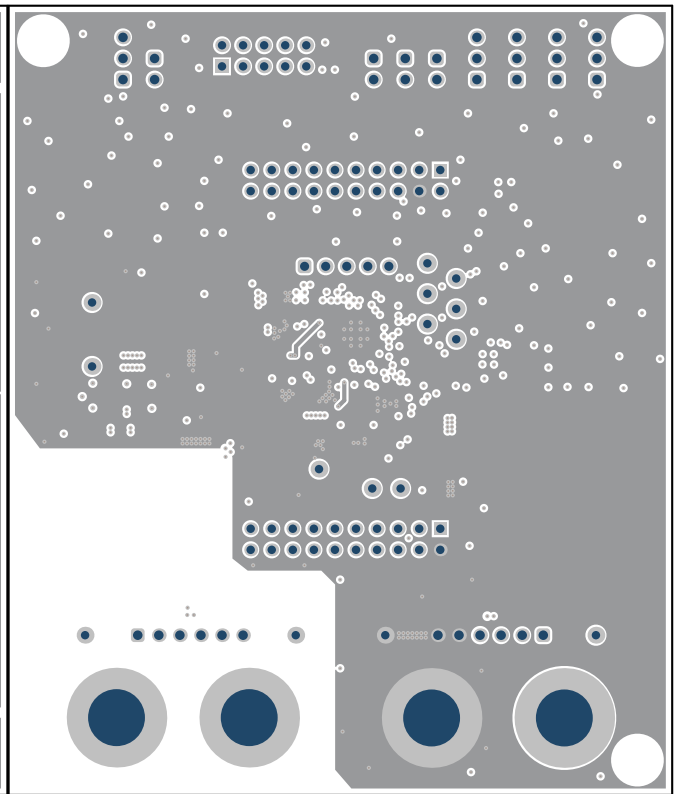

图 4-7. 中间层 3

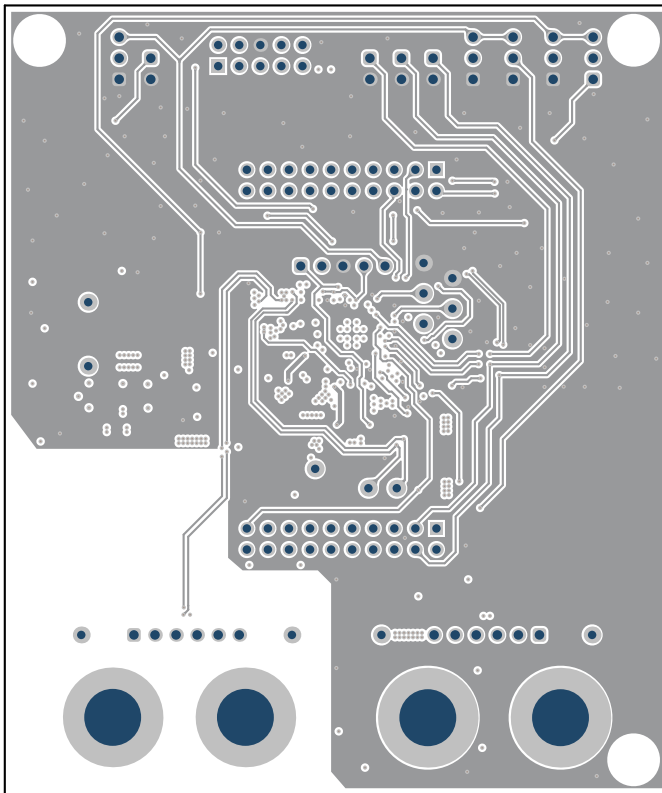

图 4-8. 中间层 4

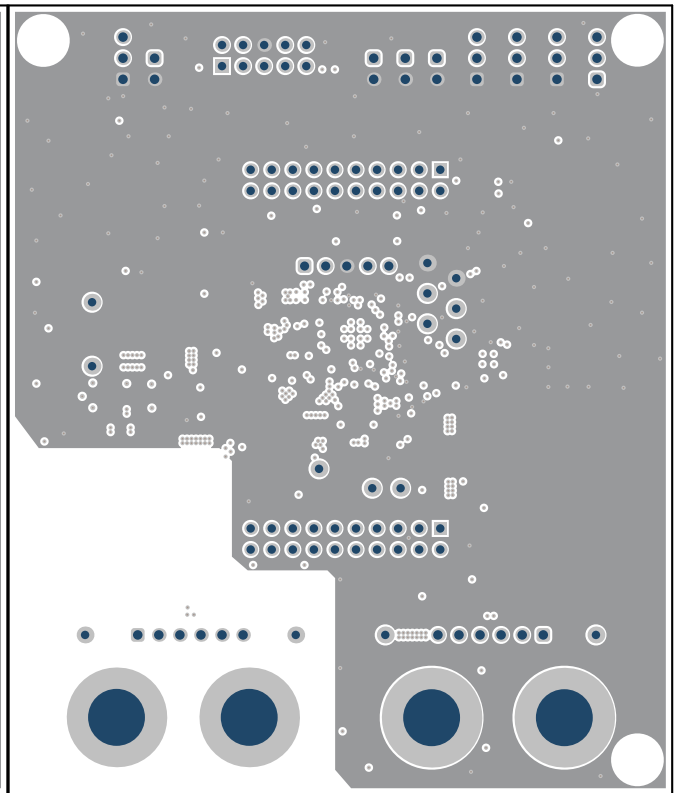

图 4-9. 底层

### 4.3 物料清单

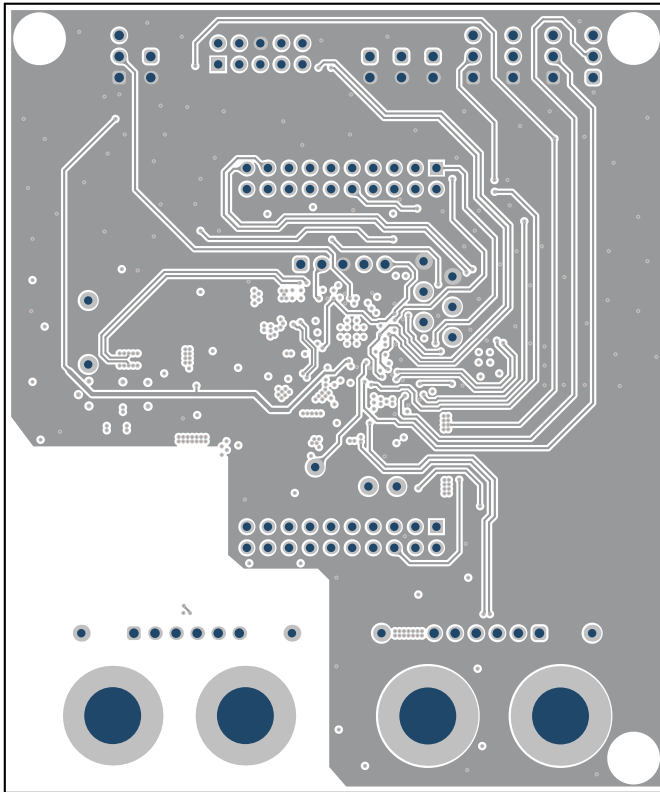
位号	数量	值	器件型号	制造商	说明
C1、C3、C5、C9、C20、C21	6	10 $\mu$ F	C3225X7R2A106K250AC	TDK	10 $\mu$ F $\pm$ 10% 100V 陶瓷电容器 X7R 1210 ( 公制 3225 )
C2、C4、C6、C8、C10、C11、C12、C13、C15、C16、C24、C28、C29、C41、C42	15	100nF	GRM155R62A104ME14D	Murata <sup>®</sup>	通用片状多层陶瓷电容器，0402，0.10 $\mu$ F，X5R，15%，20%，100V
C14	1	100pF	04025A101FAT2A	AVX	电容，陶瓷，100pF，50V， $\pm$ 1%，C0G/NP0，0402
C23、C39	2	820pF	GRM1555C1H821JA01D	MuRata	电容，陶瓷，820pF，50V， $\pm$ 5%，C0G/NP0，0402
C25	1	68pF	GRM1555C1H680JA01D	MuRata	电容，陶瓷，68pF，50V， $\pm$ 5%，C0G/NP0，0402
C26、C27	2	22 $\mu$ F	GRT188R61A226ME13D	Murata	多层陶瓷电容器，22 $\mu$ F，10V，X5R $\pm$ 20%，0603，纸质 T/R
C30	1	680pF	GRM2195C2A681JA01D	MuRata	电容，陶瓷，680pF，100V， $\pm$ 5%，C0G/NP0，0805
C31、C33	2	0.1 $\mu$ F	GRM188R72A104KA35D	MuRata	电容，陶瓷，0.1 $\mu$ F，100V， $\pm$ 10%，X7R，0603
C32	1	1000pF	GRM2195C2A102JA01D	MuRata	电容，陶瓷，1000pF，100V， $\pm$ 5%，C0G/NP0，0805
C34	1	150pF	GRM1555C1H151JA01D	MuRata	电容，陶瓷，150pF，50V， $\pm$ 5%，C0G/NP0，0402
C36	1	8200pF	GRM155R71H822KA88D	MuRata	电容，陶瓷，8200pF，50V， $\pm$ 10%，X7R，0402
C37	1	0.022 $\mu$ F	GRM155R71C223KA01D	MuRata	电容，陶瓷，0.022 $\mu$ F，16V， $\pm$ 10%，X7R，0402
C43	1	0.47 $\mu$ F	GRM21BR72A474KA73L	MuRata	电容，陶瓷，0.47 $\mu$ F，100V， $\pm$ 10%，X7R，0805
D1	1	3.3V	MMSZ4684T1G	ON Semiconductor	二极管，齐纳，3.3V，500mW，SOD-123

位号	数量	值	器件型号	制造商	说明
D2	1		BAS70-04-E3-18	Vishay	二极管阵列, 1 对串联肖特基, 70V, 200mA (DC), 表面贴装 TO-236-3, SC-59, SOT-23-3
J1、J2、J5、J6	4		108-0740-001	Cinch Connectivity	标准香蕉插孔, 非绝缘, 15A
J3、J4	2		61300611121	Würth Elektronik	插头, 2.54mm, 6×1, 镀金, TH
J7、J8	2		SSQ-110-03-T-D	Samtec®	插座, 2.54mm, 10 × 2, 锡, TH
J9、J11、JP1、JP6	4		61300211121	Würth Elektronik®	插头, 2.54mm, 2×1, 镀金, TH
J10	1		N2510-6002-RB	3M™	接头 (有罩), 100mil, 5x2, 高温, 镀金, TH
J12、J13	2		RSP-122811-01	Samtec	U.FL (UMCC), I-PEX MHFI 连接器插座, 公引脚 50Ω 表面贴装焊接
JP2	1		61300511121	Würth Elektronik	插头, 2.54mm, 5×1, 镀金, TH
JP3、JP4、JP5、JP7、JP8	5		61300311121	Würth Elektronik	插头, 2.54mm, 3×1, 镀金, TH
L1	1	3.3uH	7.44393E+11	Würth Electronics	3.3μH 屏蔽模压电感器, 20.4A, 最大 6.5mΩ, 非标准
Q1、Q2、Q3、Q4	4		IAUZN04S7L046ATMA1	Infineon™	MOSFET N 沟道 40V 72A (Tj) 45W (Tc) 表面贴装 PG-TSDSON-8-44
Q5	1	60V	CSD18540Q5B	德州仪器 (TI)	MOSFET, N 沟道, 60V, 100A, DNK0008A (VSON-CLIP-8)
R1、R3	2	10m	KRL2012E-C-R010-F-T05	Susumu	10mΩ ±1%, 1W, 片上电阻, 宽, 0805 (公制 2012), 0508, 汽车类 AEC-Q200, 电流检测, 金属箔

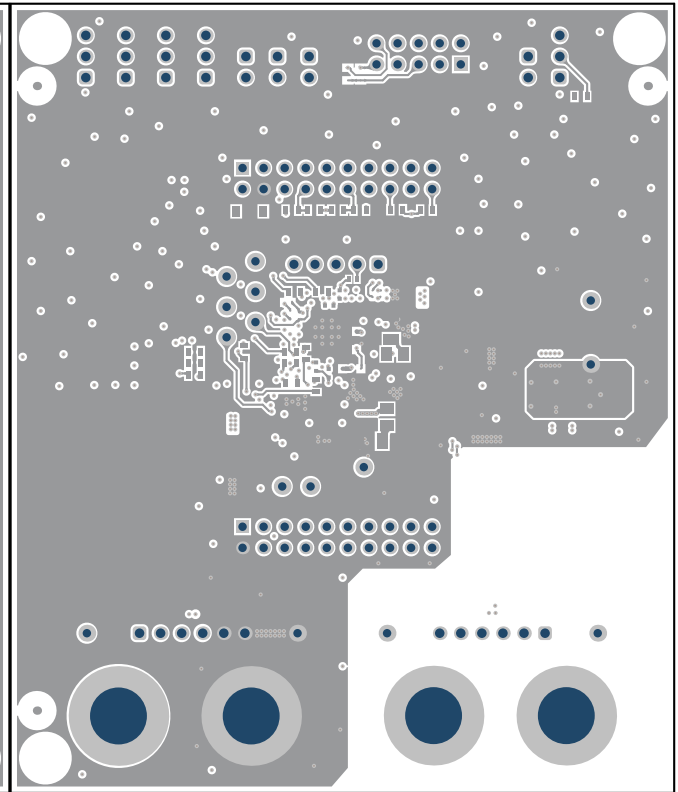
位号	数量	值	器件型号	制造商	说明
R2、R7、R9、R10、R13、R14、R15、R20、R35	9	0	ERJ-2GE0R00X	Panasonic®	0Ω 跳线片上电阻 0402 ( 公制 1005 ) , 汽车 AEC-Q200 厚膜
R4	1	4m	KRL2012E-M-R004-F-T5	Susumu™	4mΩ ±1% , 1W , 片上电阻 , 宽 , 0805 ( 公制 2012 ) , 0508 , 汽车类 AEC-Q200 , 电流检测 , 金属箔
R6、R16、R27、R33、R41、R42、R43、R49、R50、R51、R55	11	0	RMCF0603ZT0R00	Stackpole Electronics Inc	电阻 , 0 , 1% , 0.1W , AEC-Q200 0 级 , 0603
R8、R17、R18	3	10	CRCW040210R0FKED	Vishay-Dale	电阻 , 10.0 , 1% , 0.063W , AEC-Q200 0 级 , 0402
R12	1	82.0k	RC0402FR-0782KL	Yageo America	电阻 , 82.0k , 1% , 0.063W , 0402
R19	1	2.67k	CRCW04022K67FKED	Vishay-Dale	电阻 , 2.67k , 1% , 0.063W , AEC-Q200 0 级 , 0402
R21	1	75.0k	CRCW040275K0FKED	Vishay-Dale	电阻 , 75.0k , 1% , 0.063W , AEC-Q200 0 级 , 0402
R22	1	12.7k	CRCW040212K7FKED	Vishay-Dale	电阻 , 12.7k , 1% , 0.063W , AEC-Q200 0 级 , 0402
R23、R26	2	3	CRCW12063R00JNEA	Vishay-Dale	电阻 , 3.0 , 5% , 0.25W , AEC-Q200 0 级 , 1206
R28、R32	2	3	CRCW04023R00JNED	Vishay-Dale	电阻 , 3.0 , 5% , 0.063W , AEC-Q200 0 级 , 0402
R29	1	8.66k	CRCW04028K66FKED	Vishay-Dale	电阻 , 8.66k , 1% , 0.063W , AEC-Q200 0 级 , 0402
R31	1	15.4k	CRCW040215K4FKED	Vishay-Dale	电阻 , 15.4k , 1% , 0.063W , AEC-Q200 0 级 , 0402
R34	1	5.11k	CRCW04025K11FKED	Vishay-Dale	电阻 , 5.11k , 1% , 0.063W , AEC-Q200 0 级 , 0402
R37	1	2.74k	CRCW04022K74FKED	Vishay-Dale	电阻 , 2.74k , 1% , 0.063W , AEC-Q200 0 级 , 0402

位号	数量	值	器件型号	制造商	说明
R44	1	2.00k	RC0603FR-072KL	Yageo	电阻, 2.00k, 1%, 0.1W, 0603
R45、R46	2	71.5k	RC0603FR-0771K5L	Yageo	电阻, 71.5k, 1%, 0.1W, 0603
R47、R48	2	4.70k	RC0603FR-074K7L	Yageo	电阻, 4.70k, 1%, 0.1W, 0603
R53	1	18.0k	RC0603FR-0718KL	Yageo	电阻, 18.0k, 1%, 0.1W, 0603
R54	1	10.0k	RT0603BRD0710KL	Yageo America	电阻, 10.0k, 0.1%, 0.1W, 0603
TP1、TP2、TP5、TP6	4		5003	Keystone Electronics	测试点, 微型, 橙色, TH
TP3、TP14	2		5000	Keystone Electronics	测试点, 微型, 红色, TH
TP4、TP7、TP8、TP15	4		5001	Keystone Electronics	测试点, 微型, 黑色, TH
TP9、TP10、TP11、TP12、TP13	5		5004	Keystone Electronics	测试点, 微型, 黄色, TH
U1	1		LM34938QRHARQ1	德州仪器 (TI)	具有 I2C 接口的 36V VIN4 开关降压/升压控制器
C7、C17	0	27 $\mu$ F	A768KE276M1JLAE054	KEMET	电容铝制聚合物 27 $\mu$ F 63V 20% 焊接圆柱形 54m $\Omega$ 1175mA 2000 小时 125°C T/R
C18	0	100nF	GRM155R62A104ME14D	Murata	通用片状多层陶瓷电容器, 0402, 0.10 $\mu$ F, X5R, 15%, 20%, 100V
C19、C40、C44	0	10 $\mu$ F	C3225X7R2A106K250AC	TDK	10 $\mu$ F $\pm$ 10% 100V 陶瓷电容器 X7R 1210 ( 公制 3225 )
C22、C38	0	680pF	GRM1555C1H681JA01D	MuRata	电容, 陶瓷, 680pF, 50V, +/-5%, C0G/NP0, 0402
C35	0	56pF	GRM1555C1H560JA01D	MuRata	电容, 陶瓷, 56pF, 50V, +/-5%, C0G/NP0, 0402
C45	0	0.47 $\mu$ F	GRM21BR72A474KA73L	MuRata	电容, 陶瓷, 0.47 $\mu$ F, 100V, +/-10%, X7R, 0805

位号	数量	值	器件型号	制造商	说明
D3、D6	0	60V	PMEG6010CEGWJ	Nexperia	二极管, 肖特基, 60V, 1A, AEC-Q101, SOD-123
D4、D5	0	60V	PMEG6010CEJ,115	Nexperia	二极管, 肖特基, 60V, 1A, SOD-323F
L2	0	2.2uH	7.44385E+12	Würth Electronics	2.2μH 屏蔽模压电感器, 12.4A, 最大 9.3mΩ, 非标准
R5、R11、R24、R36、R38、R52	0	0	ERJ-2GE0R00X	Panasonic	0Ω 跳线片上电阻 0402 (公制 1005), 汽车 AEC-Q200 厚膜
R25	0	10.0k	MCS0402MD1002BE100	Vishay/Beyschlag	电阻, 10.0k, 0.1%, 0.1W, AEC-Q200 0 级, 0402
R30	0	40.2k	CRCW040240K2FKED	Vishay-Dale	电阻, 40.2k, 1%, 0.063W, AEC-Q200 0 级, 0402
R39、R40	0	2.00k	RC0603FR-072KL	Yageo	电阻, 2.00k, 1%, 0.1W, 0603

## 5 其他信息

### 商标

3M™ is a trademark of 3M Company.

Infineon™ is a trademark of Infineon Technologies AG.

Susumu™ is a trademark of Guangzhou Huchuang E-commerce Co., Ltd..

Murata® is a registered trademark of MURATA MANUFACTURING CO., LTD..

Samtec® is a registered trademark of Samtec Inc..

Würth Elektronik® is a registered trademark of Würth Elektronik GmbH and Co.

Panasonic® is a registered trademark of Panasonic Holdings Corporation.

所有商标均为其各自所有者的财产。

## STANDARD TERMS FOR EVALUATION MODULES

1. *Delivery:* TI delivers TI evaluation boards, kits, or modules, including any accompanying demonstration software, components, and/or documentation which may be provided together or separately (collectively, an "EVM" or "EVMs") to the User ("User") in accordance with the terms set forth herein. User's acceptance of the EVM is expressly subject to the following terms.
  - 1.1 EVMs are intended solely for product or software developers for use in a research and development setting to facilitate feasibility evaluation, experimentation, or scientific analysis of TI semiconductors products. EVMs have no direct function and are not finished products. EVMs shall not be directly or indirectly assembled as a part or subassembly in any finished product. For clarification, any software or software tools provided with the EVM ("Software") shall not be subject to the terms and conditions set forth herein but rather shall be subject to the applicable terms that accompany such Software
  - 1.2 EVMs are not intended for consumer or household use. EVMs may not be sold, sublicensed, leased, rented, loaned, assigned, or otherwise distributed for commercial purposes by Users, in whole or in part, or used in any finished product or production system.
2. *Limited Warranty and Related Remedies/Disclaimers:*
  - 2.1 These terms do not apply to Software. The warranty, if any, for Software is covered in the applicable Software License Agreement.
  - 2.2 TI warrants that the TI EVM will conform to TI's published specifications for ninety (90) days after the date TI delivers such EVM to User. Notwithstanding the foregoing, TI shall not be liable for a nonconforming EVM if (a) the nonconformity was caused by neglect, misuse or mistreatment by an entity other than TI, including improper installation or testing, or for any EVMs that have been altered or modified in any way by an entity other than TI, (b) the nonconformity resulted from User's design, specifications or instructions for such EVMs or improper system design, or (c) User has not paid on time. Testing and other quality control techniques are used to the extent TI deems necessary. TI does not test all parameters of each EVM. User's claims against TI under this Section 2 are void if User fails to notify TI of any apparent defects in the EVMs within ten (10) business days after delivery, or of any hidden defects with ten (10) business days after the defect has been detected.
  - 2.3 TI's sole liability shall be at its option to repair or replace EVMs that fail to conform to the warranty set forth above, or credit User's account for such EVM. TI's liability under this warranty shall be limited to EVMs that are returned during the warranty period to the address designated by TI and that are determined by TI not to conform to such warranty. If TI elects to repair or replace such EVM, TI shall have a reasonable time to repair such EVM or provide replacements. Repaired EVMs shall be warranted for the remainder of the original warranty period. Replaced EVMs shall be warranted for a new full ninety (90) day warranty period.

### **WARNING**

**Evaluation Kits are intended solely for use by technically qualified, professional electronics experts who are familiar with the dangers and application risks associated with handling electrical mechanical components, systems, and subsystems.**

**User shall operate the Evaluation Kit within TI's recommended guidelines and any applicable legal or environmental requirements as well as reasonable and customary safeguards. Failure to set up and/or operate the Evaluation Kit within TI's recommended guidelines may result in personal injury or death or property damage. Proper set up entails following TI's instructions for electrical ratings of interface circuits such as input, output and electrical loads.**

**NOTE:**

**EXPOSURE TO ELECTROSTATIC DISCHARGE (ESD) MAY CAUSE DEGRADATION OR FAILURE OF THE EVALUATION KIT; TI RECOMMENDS STORAGE OF THE EVALUATION KIT IN A PROTECTIVE ESD BAG.**

### 3 Regulatory Notices:

#### 3.1 United States

##### 3.1.1 Notice applicable to EVMs not FCC-Approved:

**FCC NOTICE:** This kit is designed to allow product developers to evaluate electronic components, circuitry, or software associated with the kit to determine whether to incorporate such items in a finished product and software developers to write software applications for use with the end product. This kit is not a finished product and when assembled may not be resold or otherwise marketed unless all required FCC equipment authorizations are first obtained. Operation is subject to the condition that this product not cause harmful interference to licensed radio stations and that this product accept harmful interference. Unless the assembled kit is designed to operate under part 15, part 18 or part 95 of this chapter, the operator of the kit must operate under the authority of an FCC license holder or must secure an experimental authorization under part 5 of this chapter.

##### 3.1.2 For EVMs annotated as FCC – FEDERAL COMMUNICATIONS COMMISSION Part 15 Compliant:

#### **CAUTION**

This device complies with part 15 of the FCC Rules. Operation is subject to the following two conditions: (1) This device may not cause harmful interference, and (2) this device must accept any interference received, including interference that may cause undesired operation.

Changes or modifications not expressly approved by the party responsible for compliance could void the user's authority to operate the equipment.

#### **FCC Interference Statement for Class A EVM devices**

*NOTE: This equipment has been tested and found to comply with the limits for a Class A digital device, pursuant to part 15 of the FCC Rules. These limits are designed to provide reasonable protection against harmful interference when the equipment is operated in a commercial environment. This equipment generates, uses, and can radiate radio frequency energy and, if not installed and used in accordance with the instruction manual, may cause harmful interference to radio communications. Operation of this equipment in a residential area is likely to cause harmful interference in which case the user will be required to correct the interference at his own expense.*

#### **FCC Interference Statement for Class B EVM devices**

*NOTE: This equipment has been tested and found to comply with the limits for a Class B digital device, pursuant to part 15 of the FCC Rules. These limits are designed to provide reasonable protection against harmful interference in a residential installation. This equipment generates, uses and can radiate radio frequency energy and, if not installed and used in accordance with the instructions, may cause harmful interference to radio communications. However, there is no guarantee that interference will not occur in a particular installation. If this equipment does cause harmful interference to radio or television reception, which can be determined by turning the equipment off and on, the user is encouraged to try to correct the interference by one or more of the following measures:*

- Reorient or relocate the receiving antenna.
- Increase the separation between the equipment and receiver.
- Connect the equipment into an outlet on a circuit different from that to which the receiver is connected.
- Consult the dealer or an experienced radio/TV technician for help.

#### 3.2 Canada

##### 3.2.1 For EVMs issued with an Industry Canada Certificate of Conformance to RSS-210 or RSS-247

#### **Concerning EVMs Including Radio Transmitters:**

This device complies with Industry Canada license-exempt RSSs. Operation is subject to the following two conditions:

(1) this device may not cause interference, and (2) this device must accept any interference, including interference that may cause undesired operation of the device.

#### **Concernant les EVMs avec appareils radio:**

Le présent appareil est conforme aux CNR d'Industrie Canada applicables aux appareils radio exempts de licence. L'exploitation est autorisée aux deux conditions suivantes: (1) l'appareil ne doit pas produire de brouillage, et (2) l'utilisateur de l'appareil doit accepter tout brouillage radioélectrique subi, même si le brouillage est susceptible d'en compromettre le fonctionnement.

#### **Concerning EVMs Including Detachable Antennas:**

Under Industry Canada regulations, this radio transmitter may only operate using an antenna of a type and maximum (or lesser) gain approved for the transmitter by Industry Canada. To reduce potential radio interference to other users, the antenna type and its gain should be so chosen that the equivalent isotropically radiated power (e.i.r.p.) is not more than that necessary for successful communication. This radio transmitter has been approved by Industry Canada to operate with the antenna types listed in the user guide with the maximum permissible gain and required antenna impedance for each antenna type indicated. Antenna types not included in this list, having a gain greater than the maximum gain indicated for that type, are strictly prohibited for use with this device.

### Concernant les EVMs avec antennes détachables

Conformément à la réglementation d'Industrie Canada, le présent émetteur radio peut fonctionner avec une antenne d'un type et d'un gain maximal (ou inférieur) approuvé pour l'émetteur par Industrie Canada. Dans le but de réduire les risques de brouillage radioélectrique à l'intention des autres utilisateurs, il faut choisir le type d'antenne et son gain de sorte que la puissance isotrope rayonnée équivalente (p.i.r.e.) ne dépasse pas l'intensité nécessaire à l'établissement d'une communication satisfaisante. Le présent émetteur radio a été approuvé par Industrie Canada pour fonctionner avec les types d'antenne énumérés dans le manuel d'usage et ayant un gain admissible maximal et l'impédance requise pour chaque type d'antenne. Les types d'antenne non inclus dans cette liste, ou dont le gain est supérieur au gain maximal indiqué, sont strictement interdits pour l'exploitation de l'émetteur.

#### 3.3 Japan

3.3.1 *Notice for EVMs delivered in Japan:* Please see [http://www.tij.co.jp/lstds/ti\\_ja/general/eStore/notice\\_01.page](http://www.tij.co.jp/lstds/ti_ja/general/eStore/notice_01.page) 日本国内に輸入される評価用キット、ボードについては、次のところをご覧ください。

<https://www.ti.com/ja-jp/legal/notice-for-evaluation-kits-delivered-in-japan.html>

3.3.2 *Notice for Users of EVMs Considered "Radio Frequency Products" in Japan:* EVMs entering Japan may not be certified by TI as conforming to Technical Regulations of Radio Law of Japan.

If User uses EVMs in Japan, not certified to Technical Regulations of Radio Law of Japan, User is required to follow the instructions set forth by Radio Law of Japan, which includes, but is not limited to, the instructions below with respect to EVMs (which for the avoidance of doubt are stated strictly for convenience and should be verified by User):

1. Use EVMs in a shielded room or any other test facility as defined in the notification #173 issued by Ministry of Internal Affairs and Communications on March 28, 2006, based on Sub-section 1.1 of Article 6 of the Ministry's Rule for Enforcement of Radio Law of Japan,
2. Use EVMs only after User obtains the license of Test Radio Station as provided in Radio Law of Japan with respect to EVMs, or
3. Use of EVMs only after User obtains the Technical Regulations Conformity Certification as provided in Radio Law of Japan with respect to EVMs. Also, do not transfer EVMs, unless User gives the same notice above to the transferee. Please note that if User does not follow the instructions above, User will be subject to penalties of Radio Law of Japan.

【無線電波を送信する製品の開発キットをお使いになる際の注意事項】 開発キットの中には技術基準適合証明を受けていないものがあります。技術適合証明を受けていないものご使用に際しては、電波法遵守のため、以下のいずれかの措置を取っていただく必要がありますのでご注意ください。

1. 電波法施行規則第6条第1項第1号に基づく平成18年3月28日総務省告示第173号で定められた電波暗室等の試験設備でご使用いただく。
2. 実験局の免許を取得後ご使用いただく。
3. 技術基準適合証明を取得後ご使用いただく。

なお、本製品は、上記の「ご使用にあたっての注意」を譲渡先、移転先に通知しない限り、譲渡、移転できないものとします。

上記を遵守頂けない場合は、電波法の罰則が適用される可能性があることをご留意ください。日本テキサス・イ

ンスツルメンツ株式会社

東京都新宿区西新宿 6 丁目 2 4 番 1 号

西新宿三井ビル

3.3.3 *Notice for EVMs for Power Line Communication:* Please see [http://www.tij.co.jp/lstds/ti\\_ja/general/eStore/notice\\_02.page](http://www.tij.co.jp/lstds/ti_ja/general/eStore/notice_02.page)

電力線搬送波通信についての開発キットをお使いになる際の注意事項については、次のところをご覧ください。 <https://www.ti.com/ja-jp/legal/notice-for-evaluation-kits-for-power-line-communication.html>

#### 3.4 European Union

3.4.1 *For EVMs subject to EU Directive 2014/30/EU (Electromagnetic Compatibility Directive):*

This is a class A product intended for use in environments other than domestic environments that are connected to a low-voltage power-supply network that supplies buildings used for domestic purposes. In a domestic environment this product may cause radio interference in which case the user may be required to take adequate measures.

- 
4. *EVM Use Restrictions and Warnings:*
    - 4.1 EVMS ARE NOT FOR USE IN FUNCTIONAL SAFETY AND/OR SAFETY CRITICAL EVALUATIONS, INCLUDING BUT NOT LIMITED TO EVALUATIONS OF LIFE SUPPORT APPLICATIONS.
    - 4.2 User must read and apply the user guide and other available documentation provided by TI regarding the EVM prior to handling or using the EVM, including without limitation any warning or restriction notices. The notices contain important safety information related to, for example, temperatures and voltages.
    - 4.3 *Safety-Related Warnings and Restrictions:*
      - 4.3.1 User shall operate the EVM within TI's recommended specifications and environmental considerations stated in the user guide, other available documentation provided by TI, and any other applicable requirements and employ reasonable and customary safeguards. Exceeding the specified performance ratings and specifications (including but not limited to input and output voltage, current, power, and environmental ranges) for the EVM may cause personal injury or death, or property damage. If there are questions concerning performance ratings and specifications, User should contact a TI field representative prior to connecting interface electronics including input power and intended loads. Any loads applied outside of the specified output range may also result in unintended and/or inaccurate operation and/or possible permanent damage to the EVM and/or interface electronics. Please consult the EVM user guide prior to connecting any load to the EVM output. If there is uncertainty as to the load specification, please contact a TI field representative. During normal operation, even with the inputs and outputs kept within the specified allowable ranges, some circuit components may have elevated case temperatures. These components include but are not limited to linear regulators, switching transistors, pass transistors, current sense resistors, and heat sinks, which can be identified using the information in the associated documentation. When working with the EVM, please be aware that the EVM may become very warm.
      - 4.3.2 EVMs are intended solely for use by technically qualified, professional electronics experts who are familiar with the dangers and application risks associated with handling electrical mechanical components, systems, and subsystems. User assumes all responsibility and liability for proper and safe handling and use of the EVM by User or its employees, affiliates, contractors or designees. User assumes all responsibility and liability to ensure that any interfaces (electronic and/or mechanical) between the EVM and any human body are designed with suitable isolation and means to safely limit accessible leakage currents to minimize the risk of electrical shock hazard. User assumes all responsibility and liability for any improper or unsafe handling or use of the EVM by User or its employees, affiliates, contractors or designees.
    - 4.4 User assumes all responsibility and liability to determine whether the EVM is subject to any applicable international, federal, state, or local laws and regulations related to User's handling and use of the EVM and, if applicable, User assumes all responsibility and liability for compliance in all respects with such laws and regulations. User assumes all responsibility and liability for proper disposal and recycling of the EVM consistent with all applicable international, federal, state, and local requirements.
  5. *Accuracy of Information:* To the extent TI provides information on the availability and function of EVMs, TI attempts to be as accurate as possible. However, TI does not warrant the accuracy of EVM descriptions, EVM availability or other information on its websites as accurate, complete, reliable, current, or error-free.
  6. *Disclaimers:*
    - 6.1 EXCEPT AS SET FORTH ABOVE, EVMS AND ANY MATERIALS PROVIDED WITH THE EVM (INCLUDING, BUT NOT LIMITED TO, REFERENCE DESIGNS AND THE DESIGN OF THE EVM ITSELF) ARE PROVIDED "AS IS" AND "WITH ALL FAULTS." TI DISCLAIMS ALL OTHER WARRANTIES, EXPRESS OR IMPLIED, REGARDING SUCH ITEMS, INCLUDING BUT NOT LIMITED TO ANY EPIDEMIC FAILURE WARRANTY OR IMPLIED WARRANTIES OF MERCHANTABILITY OR FITNESS FOR A PARTICULAR PURPOSE OR NON-INFRINGEMENT OF ANY THIRD PARTY PATENTS, COPYRIGHTS, TRADE SECRETS OR OTHER INTELLECTUAL PROPERTY RIGHTS.
    - 6.2 EXCEPT FOR THE LIMITED RIGHT TO USE THE EVM SET FORTH HEREIN, NOTHING IN THESE TERMS SHALL BE CONSTRUED AS GRANTING OR CONFERRING ANY RIGHTS BY LICENSE, PATENT, OR ANY OTHER INDUSTRIAL OR INTELLECTUAL PROPERTY RIGHT OF TI, ITS SUPPLIERS/LICENSORS OR ANY OTHER THIRD PARTY, TO USE THE EVM IN ANY FINISHED END-USER OR READY-TO-USE FINAL PRODUCT, OR FOR ANY INVENTION, DISCOVERY OR IMPROVEMENT, REGARDLESS OF WHEN MADE, CONCEIVED OR ACQUIRED.
  7. *USER'S INDEMNITY OBLIGATIONS AND REPRESENTATIONS.* USER WILL DEFEND, INDEMNIFY AND HOLD TI, ITS LICENSORS AND THEIR REPRESENTATIVES HARMLESS FROM AND AGAINST ANY AND ALL CLAIMS, DAMAGES, LOSSES, EXPENSES, COSTS AND LIABILITIES (COLLECTIVELY, "CLAIMS") ARISING OUT OF OR IN CONNECTION WITH ANY HANDLING OR USE OF THE EVM THAT IS NOT IN ACCORDANCE WITH THESE TERMS. THIS OBLIGATION SHALL APPLY WHETHER CLAIMS ARISE UNDER STATUTE, REGULATION, OR THE LAW OF TORT, CONTRACT OR ANY OTHER LEGAL THEORY, AND EVEN IF THE EVM FAILS TO PERFORM AS DESCRIBED OR EXPECTED.
-

8. *Limitations on Damages and Liability:*

8.1 *General Limitations.* IN NO EVENT SHALL TI BE LIABLE FOR ANY SPECIAL, COLLATERAL, INDIRECT, PUNITIVE, INCIDENTAL, CONSEQUENTIAL, OR EXEMPLARY DAMAGES IN CONNECTION WITH OR ARISING OUT OF THESE TERMS OR THE USE OF THE EVMS , REGARDLESS OF WHETHER TI HAS BEEN ADVISED OF THE POSSIBILITY OF SUCH DAMAGES. EXCLUDED DAMAGES INCLUDE, BUT ARE NOT LIMITED TO, COST OF REMOVAL OR REINSTALLATION, ANCILLARY COSTS TO THE PROCUREMENT OF SUBSTITUTE GOODS OR SERVICES, RETESTING, OUTSIDE COMPUTER TIME, LABOR COSTS, LOSS OF GOODWILL, LOSS OF PROFITS, LOSS OF SAVINGS, LOSS OF USE, LOSS OF DATA, OR BUSINESS INTERRUPTION. NO CLAIM, SUIT OR ACTION SHALL BE BROUGHT AGAINST TI MORE THAN TWELVE (12) MONTHS AFTER THE EVENT THAT GAVE RISE TO THE CAUSE OF ACTION HAS OCCURRED.

8.2 *Specific Limitations.* IN NO EVENT SHALL TI'S AGGREGATE LIABILITY FROM ANY USE OF AN EVM PROVIDED HEREUNDER, INCLUDING FROM ANY WARRANTY, INDEMNITY OR OTHER OBLIGATION ARISING OUT OF OR IN CONNECTION WITH THESE TERMS, , EXCEED THE TOTAL AMOUNT PAID TO TI BY USER FOR THE PARTICULAR EVM(S) AT ISSUE DURING THE PRIOR TWELVE (12) MONTHS WITH RESPECT TO WHICH LOSSES OR DAMAGES ARE CLAIMED. THE EXISTENCE OF MORE THAN ONE CLAIM SHALL NOT ENLARGE OR EXTEND THIS LIMIT.

9. *Return Policy.* Except as otherwise provided, TI does not offer any refunds, returns, or exchanges. Furthermore, no return of EVM(s) will be accepted if the package has been opened and no return of the EVM(s) will be accepted if they are damaged or otherwise not in a resalable condition. If User feels it has been incorrectly charged for the EVM(s) it ordered or that delivery violates the applicable order, User should contact TI. All refunds will be made in full within thirty (30) working days from the return of the components(s), excluding any postage or packaging costs.

10. *Governing Law:* These terms and conditions shall be governed by and interpreted in accordance with the laws of the State of Texas, without reference to conflict-of-laws principles. User agrees that non-exclusive jurisdiction for any dispute arising out of or relating to these terms and conditions lies within courts located in the State of Texas and consents to venue in Dallas County, Texas. Notwithstanding the foregoing, any judgment may be enforced in any United States or foreign court, and TI may seek injunctive relief in any United States or foreign court.

Mailing Address: Texas Instruments, Post Office Box 655303, Dallas, Texas 75265  
Copyright © 2023, Texas Instruments Incorporated

## 重要通知和免责声明

TI“按原样”提供技术和可靠性数据（包括数据表）、设计资源（包括参考设计）、应用或其他设计建议、网络工具、安全信息和其他资源，不保证没有瑕疵且不做任何明示或暗示的担保，包括但不限于对适销性、与某特定用途的适用性或不侵犯任何第三方知识产权的暗示担保。

这些资源可供使用 TI 产品进行设计的熟练开发人员使用。您将自行承担以下全部责任：(1) 针对您的应用选择合适的 TI 产品，(2) 设计、验证并测试您的应用，(3) 确保您的应用满足相应标准以及任何其他安全、安保法规或其他要求。

这些资源如有变更，恕不另行通知。TI 授权您仅可将这些资源用于研发本资源所述的 TI 产品的相关应用。严禁以其他方式对这些资源进行复制或展示。您无权使用任何其他 TI 知识产权或任何第三方知识产权。对于因您对这些资源的使用而对 TI 及其代表造成的任何索赔、损害、成本、损失和债务，您将全额赔偿，TI 对此概不负责。

TI 提供的产品受 [TI 销售条款](#)、[TI 通用质量指南](#) 或 [ti.com](#) 上其他适用条款或 TI 产品随附的其他适用条款的约束。TI 提供这些资源并不会扩展或以其他方式更改 TI 针对 TI 产品发布的适用的担保或担保免责声明。除非德州仪器 (TI) 明确将某产品指定为定制产品或客户特定产品，否则其产品均为按确定价格收入目录的标准通用器件。

TI 反对并拒绝您可能提出的任何其他或不同的条款。

版权所有 © 2026，德州仪器 (TI) 公司

最后更新日期：2025 年 10 月