

## AM26C32 クワッド差動ライン・レシーバ

### 1 特長

- ANSI TIA/EIA-422-B、TIA/EIA-423-B、および ITU 勧告 V.10 および V.11 の要件を満たす、または超える
- 低消費電力、 $I_{CC} = 10\text{mA}$  (標準値)
- $\pm 200\text{mV}$  の感度で  $\pm 7\text{V}$  の同相範囲
- 入力ヒステリシス:  $60\text{mV}$  (標準値)
- $t_{pd} = 17\text{ns}$  (標準値)
- 5V 単一電源で動作
- 3 ステート出力
- 入力フェールセーフ回路
- AM26LS32 デバイスの改良代替品
- 車載対応 Q-Temp で利用可能

### 2 アプリケーション

- 高信頼性の車載用アプリケーション
- ファクトリ・オートメーション
- ATM / キャッシュ・カウンタ
- スマート・グリッド
- AC / サーボ・モータ・ドライブ

### 3 概要

AM26C32 デバイスは、平衡または不平衡デジタル・データ伝送用クワッド差動ライン・レシーバです。イネーブル機能は 4 つのレシーバすべてに共通で、アクティブ High またはアクティブ Low の入力を選択できます。3 ステート出力により、バス構成システムに直接接続できます。フェールセーフ設計により、入力がオープンの場合、出力は常に High であることが規定されています。AM26C32 デバイスは、バイポーラ・トランジスタと CMOS トランジスタを組み合わせた BiCMOS プロセスで製造されています。このプロセスは、バイポーラの高電圧および大電流に CMOS の低消費電力を提供し、AC および DC 性能を維持しながら消費電力を通常の AM26LS32 の約 1/5 に抑えます。

#### パッケージ情報

部品番号	パッケージ (1)	パッケージ・サイズ (2)
AM26C32	PDIP (N, 16)	19.3mm × 9.4mm
	SO (NS, 16)	10.2mm × 7.8mm
	SOIC (D, 16)	9.9mm × 6mm
	SSOP (DB, 16)	6.2mm × 7.8mm
	TSSOP (PW, 16)	5mm × 6.4mm
	CDIP (J, 16)	mm × 6.92mm
	CFP (W, 16)	10.3mm × 6.73mm
	LCCC (FK, 20)	8.90mm × 8.90mm

- 詳細については、[セクション 11](#) を参照してください。
- パッケージ・サイズ (長さ×幅) は公称値であり、該当する場合はピンも含まれます。

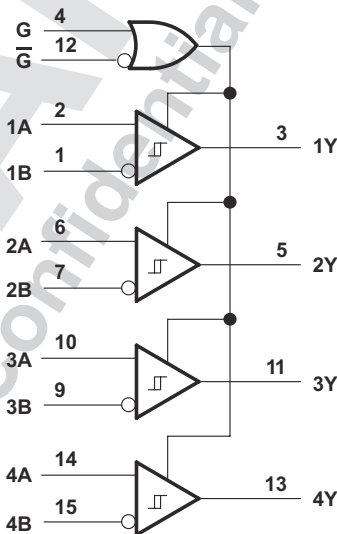

概略回路図



## Table of Contents

1 特長.....	1	7.3 Feature Description.....	8
2 アプリケーション.....	1	7.4 Device Functional Modes.....	9
3 概要.....	1	<b>8 Application and Implementation.....</b>	<b>10</b>
<b>4 Pin Configuration and Functions.....</b>	<b>3</b>	8.1 Application Information.....	10
<b>5 Specifications.....</b>	<b>4</b>	8.2 Typical Application.....	10
5.1 Absolute Maximum Ratings.....	4	8.3 Power Supply Recommendations.....	11
5.2 ESD Ratings.....	4	8.4 Layout.....	11
5.3 Recommended Operating Conditions.....	4	<b>9 Device and Documentation Support.....</b>	<b>13</b>
5.4 Thermal Information.....	5	9.1 ドキュメントの更新通知を受け取る方法.....	13
5.5 Thermal Information.....	5	9.2 サポート・リソース.....	13
5.6 Electrical Characteristics.....	5	9.3 Trademarks.....	13
5.7 Switching Characteristics.....	6	9.4 静電気放電に関する注意事項.....	13
5.8 Typical Characteristics.....	6	9.5 用語集.....	13
<b>6 Parameter Measurement Information.....</b>	<b>7</b>	<b>10 Revision History.....</b>	<b>13</b>
<b>7 Detailed Description.....</b>	<b>8</b>	<b>11 Mechanical, Packaging, and Orderable Information.....</b>	<b>14</b>
7.1 Overview.....	8		
7.2 Functional Block Diagram.....	8		

## 4 Pin Configuration and Functions

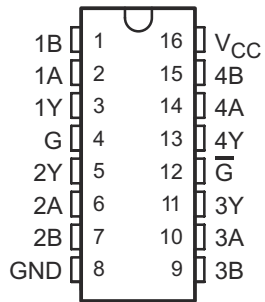

**图 4-1. D, DB, N, NS, PW, J or W Package  
 16-Pin SOIC, PDIP, SO, TSSOP, CDIP, or CFP  
 (Top View)**

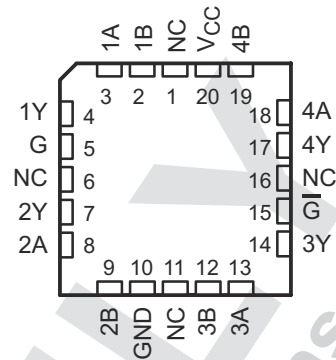

**图 4-2. FK Package, 20-Pin LCCC  
 (Top View)**

NAME	PIN		I/O	DESCRIPTION
	LCCC	SOIC, PDIP, SO, TSSOP, CFP, or CDIP		
1A	3	2	I	RS422/RS485 differential input (noninverting)
1B	2	1	I	RS422/RS485 differential input (inverting)
1Y	4	3	O	Logic level output
2A	8	6	I	RS422/RS485 differential input (noninverting)
2B	9	7	I	RS422/RS485 differential input (inverting)
2Y	7	5	O	Logic level output
3A	13	10	I	RS422/RS485 differential input (noninverting)
3B	12	9	I	RS422/RS485 differential input (inverting)
3Y	14	11	O	Logic level output
4A	18	14	I	RS422/RS485 differential input (noninverting)
4B	19	15	I	RS422/RS485 differential input (inverting)
4Y	17	13	O	Logic level output
G	5	4	I	Active-high select
$\bar{G}$	15	12	I	Active-low select
GND	10	8	—	Ground
NC <sup>(1)</sup>	1	—	—	Do not connect
	6	—	—	
	11	—	—	
	16	—	—	
V <sub>CC</sub>	20	16	—	Power Supply

(1) NC – no internal connection.

## 5 Specifications

### 5.1 Absolute Maximum Ratings

over operating free-air temperature range (unless otherwise noted) <sup>(1)</sup>

		MIN	MAX	UNIT	
V <sub>CC</sub>	Supply voltage <sup>(2)</sup>		7	V	
V <sub>I</sub>	Input voltage	A or B inputs	-11	14	V
		G or $\bar{G}$ inputs	-0.5	V <sub>CC</sub> + 0.5	
V <sub>ID</sub>	Differential input voltage	-14	14	V	
V <sub>O</sub>	Output voltage	-0.5	V <sub>CC</sub> + 0.5	V	
I <sub>O</sub>	Output current		±25	mA	
T <sub>stg</sub>	Storage temperature	-65	150	°C	

- (1) Stresses beyond those listed under *Absolute Maximum Ratings* may cause permanent damage to the device. These are stress ratings only, which do not imply functional operation of the device at these or any other conditions beyond those indicated under *Recommended Operating Conditions*. Exposure to absolute-maximum-rated conditions for extended periods may affect device reliability.
- (2) All voltage values, except differential voltages, are with respect to the network ground terminal.

### 5.2 ESD Ratings

		VALUE	UNIT
V <sub>(ESD)</sub>	Electrostatic discharge	Human body model (HBM), per ANSI/ESDA/JEDEC JS-001 <sup>(1)</sup>	±3000
		Charged-device model (CDM), per JEDEC specification JESD22-C101 <sup>(2)</sup>	±2000

- (1) JEDEC document JEP155 states that 500-V HBM allows safe manufacturing with a standard ESD control process.
- (2) JEDEC document JEP157 states that 250-V CDM allows safe manufacturing with a standard ESD control process.

### 5.3 Recommended Operating Conditions

over operating free-air temperature range (unless otherwise noted)

		MIN	NOM	MAX	UNIT	
V <sub>CC</sub>	Supply voltage	4.5	5	5.5	V	
V <sub>IH</sub>	High-level input voltage	2		V <sub>CC</sub>	V	
V <sub>IL</sub>	Low-level input voltage	0		0.8	V	
V <sub>IC</sub>	Common-mode input voltage	-7		+7	V	
I <sub>OH</sub>	High-level output current			-6	mA	
I <sub>OL</sub>	Low-level output current			6	mA	
T <sub>A</sub>	Operating free-air temperature	AM26C32C		0	70	°C
		AM26C32I		-40	85	
		AM26C32Q		-40	125	
		AM26C32M		-55	125	

## 5.4 Thermal Information

THERMAL METRIC <sup>(1)</sup>		D (SOIC)	DB (SSOP)	N (PDIP)	NS (SO)	PW (TSSOP)	UNIT
		16 PINS	16 PINS	16 PINS	16 PINS	16 PINS	
R <sub>θJA</sub>	Junction-to-ambient thermal resistance	84.6	102.6	60.6	88.5	107.5	°C/W
R <sub>θJC(top)</sub>	Junction-to-case(top) thermal resistance	43.5	48.7	48.1	46.2	38.4	°C/W
R <sub>θJB</sub>	Junction-to-board thermal resistance	43.2	54.3	40.6	50.7	53.7	°C/W
Ψ <sub>JT</sub>	Junction-to-top characterization parameter	10.4	11.8	27.5	13.5	3.2	°C/W
Ψ <sub>JB</sub>	Junction-to-bottom characterization parameter	42.8	53.5	40.3	50.3	53.1	°C/W

(1) For more information about traditional and new thermal metrics, see the *Semiconductor and IC Package Thermal Metrics* application report, [SPRA953](#).

## 5.5 Thermal Information

THERMAL METRIC <sup>(1)</sup>		J (CDIP)	FK (LCCC)	W (CFP)	UNIT
		16 PINS	20 PINS	16 PINS	
R <sub>θJA</sub>	Junction-to-ambient thermal resistance	65.6	61.6	99.5	°C/W
R <sub>θJC(top)</sub>	Junction-to-case(top) thermal resistance	54.6	36.8	51.5	°C/W
R <sub>θJB</sub>	Junction-to-board thermal resistance	42.1	36.1	86.5	°C/W
Ψ <sub>JT</sub>	Junction-to-top characterization parameter	22.9	31	23.7	°C/W
Ψ <sub>JB</sub>	Junction-to-bottom characterization parameter	41.6	36	80.2	°C/W
R <sub>θJC(bottom)</sub>	Junction-to-case(bottom) thermal resistance	N/A	4.2	N/A	°C/W

(1) For more information about traditional and new thermal metrics, see the *Semiconductor and IC Package Thermal Metrics* application report, [SPRA953](#).

## 5.6 Electrical Characteristics

over operating free-air temperature range (unless otherwise noted)

PARAMETER		TEST CONDITIONS		MIN	TYP <sup>(1)</sup>	MAX	UNIT
V <sub>IT+</sub>	Differential input high-threshold voltage	V <sub>O</sub> = V <sub>OH(min)</sub> , I <sub>OH</sub> = -440 μA	V <sub>IC</sub> = -7 V to 7 V			0.2	V
			V <sub>IC</sub> = 0 V to 5.5 V			0.1	
V <sub>IT-</sub>	Differential input low-threshold voltage	V <sub>O</sub> = 0.45 V, I <sub>OL</sub> = 8 mA	V <sub>IC</sub> = -7 V to 7 V			-0.2 <sup>(2)</sup>	V
			V <sub>IC</sub> = 0 V to 5.5 V			-0.1 <sup>(2)</sup>	
V <sub>hys</sub>	Hysteresis voltage (V <sub>IT+</sub> - V <sub>IT-</sub> )				60		mV
V <sub>IK</sub>	Enable input clamp voltage	V <sub>CC</sub> = 4.5 V, I <sub>I</sub> = -18 mA				-1.5	V
V <sub>OH</sub>	High-level output voltage	V <sub>ID</sub> = 200 mV, I <sub>OH</sub> = -6 mA		3.8			V
V <sub>OL</sub>	Low-level output voltage	V <sub>ID</sub> = -200 mV, I <sub>OL</sub> = 6 mA			0.2	0.3	V
I <sub>OZ</sub>	OFF-state (high-impedance state) output current	V <sub>O</sub> = V <sub>CC</sub> or GND			±0.5	±5	μA
I <sub>I</sub>	Line input current	V <sub>I</sub> = 10 V, Other input at 0 V				1.5	mA
		V <sub>I</sub> = -10 V, Other input at 0 V				-2.5	mA
I <sub>IH</sub>	High-level enable current	V <sub>I</sub> = 2.7 V				20	μA
I <sub>IL</sub>	Low-level enable current	V <sub>I</sub> = 0.4 V				-100	μA
r <sub>i</sub>	Input resistance	One input to ground		12	17		kΩ
I <sub>CC</sub>	Quiescent supply current	V <sub>CC</sub> = 5.5 V			10	15	mA

(1) All typical values are at V<sub>CC</sub> = 5 V, V<sub>IC</sub> = 0, and T<sub>A</sub> = 25°C.

(2) The algebraic convention, in which the less positive (more negative) limit is designated minimum, is used in this data sheet for common-mode input voltage.

## 5.7 Switching Characteristics

over operating free-air temperature range,  $C_L = 50$  pF (unless otherwise noted)

PARAMETER	TEST CONDITIONS	AM26C32C AM26C32I			AM26C32Q AM26C32M			UNIT
		MIN	TYP <sup>(1)</sup>	MAX	MIN	TYP <sup>(1)</sup>	MAX	
$t_{PLH}$ Propagation delay time, low- to high-level output	See <a href="#">6-1</a>	9	17	27	9	17	27	ns
$t_{PHL}$ Propagation delay time, high- to low-level output		9	17	27	9	17	27	ns
$t_{TLH}$ Output transition time, low- to high-level output	See <a href="#">6-1</a>		4	9		4	10	ns
$t_{THL}$ Output transition time, high- to low-level output			4	9		4	9	ns
$t_{PZH}$ Output enable time to high-level	See <a href="#">6-2</a>		13	22		13	22	ns
$t_{PZL}$ Output enable time to low-level			13	22		13	22	ns
$t_{PHZ}$ Output disable time from high-level	See <a href="#">6-2</a>		13	22		13	26	ns
$t_{PLZ}$ Output disable time from low-level			13	22		13	25	ns

(1) All typical values are at  $V_{CC} = 5$  V,  $T_A = 25^\circ\text{C}$ .

## 5.8 Typical Characteristics

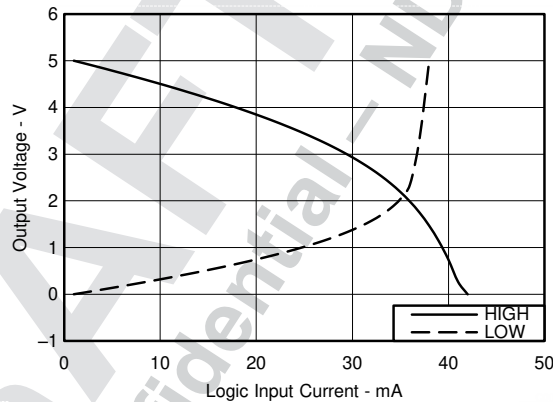

**5-1. Output Voltage vs Input Current**

## 6 Parameter Measurement Information

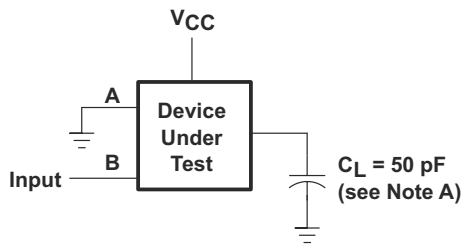

TEST CIRCUIT

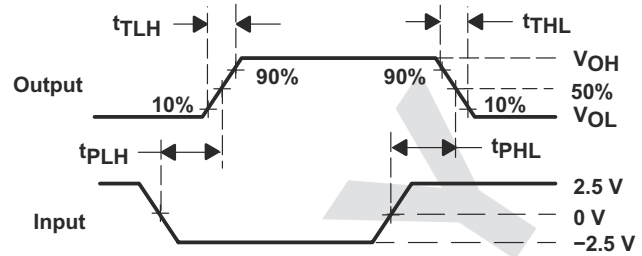

VOLTAGE WAVEFORMS

A.  $C_L$  includes probe and jig capacitance.

图 6-1. Switching Test Circuit and Voltage Waveforms

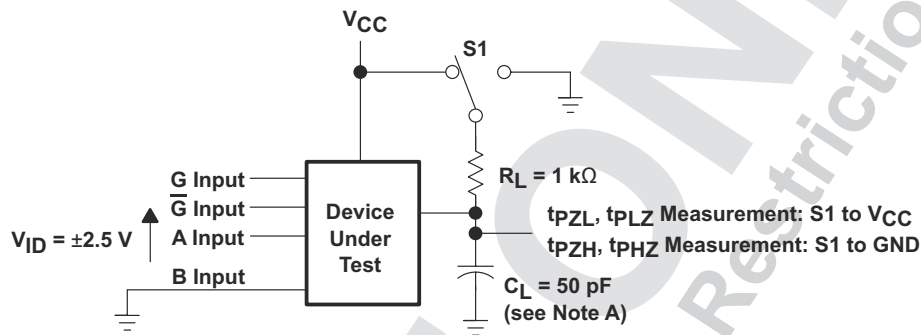

TEST CIRCUIT

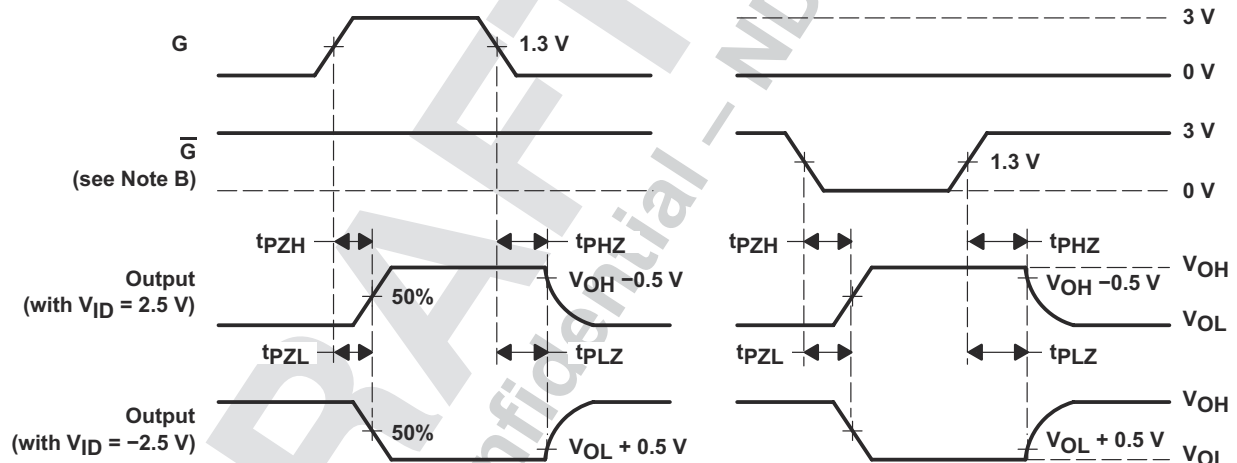

VOLTAGE WAVEFORMS

A.  $C_L$  includes probe and jig capacitance.

B. The input pulse is supplied by a generator having the following characteristics: PRR = 1 MHz, duty cycle  $\leq$  50%,  $t_r = t_f = 6$  ns.

图 6-2. Enable/Disable Time Test Circuit and Output Voltage Waveforms

## 7 Detailed Description

### 7.1 Overview

The AM26C32 is a quadruple differential line receiver that meets the necessary requirements for NSI TIA/EIA-422-B, TIA/EIA-423-B, and ITU Recommendation V.10 and V.11. This device allows a low power or low voltage MCU to interface with heavy machinery, subsystems and other devices through long wires of up to 1000m, giving any design a reliable and easy to use connection. As any RS422 interface, the AM26C32 works in a differential voltage range, which enables very good signal integrity.

### 7.2 Functional Block Diagram

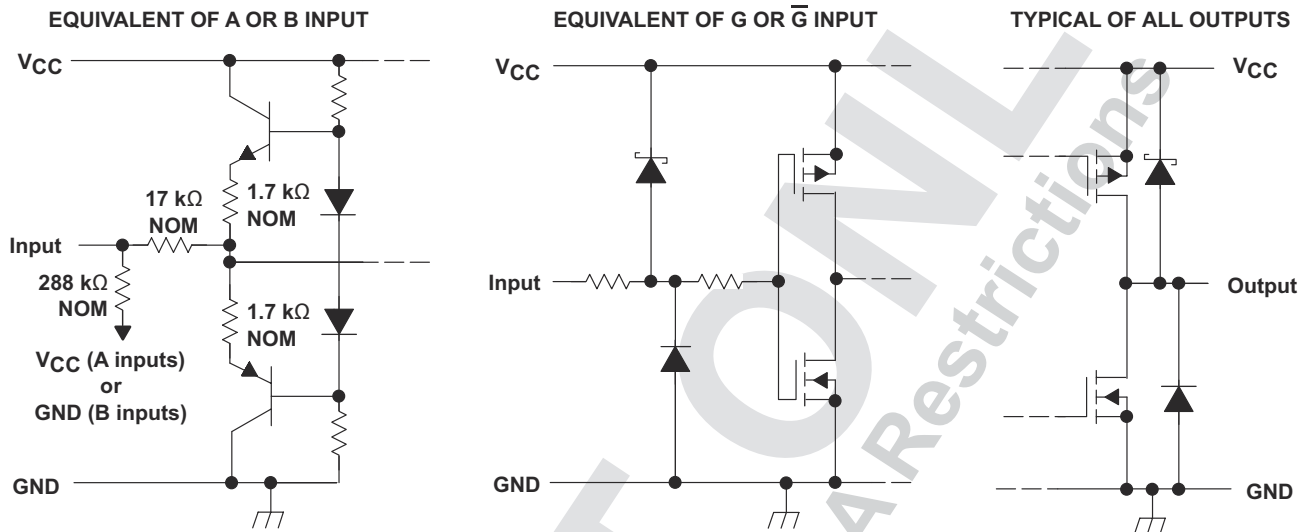

### 7.3 Feature Description

#### 7.3.1 ±7-V Common-Mode Range With ±200-mV Sensitivity

For a common-mode voltage varying from -7V to 7V, the input voltage is acceptable in low ranges greater than 200 mV as a standard.

#### 7.3.2 Input Fail-Safe Circuitry

RS-485 specifies that the receiver output state should be logic high for differential input voltages of  $V_{AB} \geq +200$  mV and logic low for  $V_{AB} \leq -200$  mV. For input voltages in between these limits, a receiver's output state is not defined and can randomly assume high or low. Removing the uncertainty of random output states, modern transceiver designs include internal biasing circuits that put the receiver output into a defined state (typically high) in the absence of a valid input signal.

A loss of input signal can be caused by an open circuit caused by a wire break or the unintentional disconnection of a transceiver from the bus. The AM26C32 has an internal circuit that ensures functionality during an idle bus.

#### 7.3.3 Active-High and Active-Low

The device can be configured using the G and  $\bar{G}$  logic inputs to select receiver output. The high voltage or logic 1 on the G pin, allows the device to operate on an active-high and having a low voltage or logic 0 on the  $\bar{G}$  enables active low operation. These are simply a way to configure the logic to match that of the receiving or transmitting controller or microprocessor.

#### 7.3.4 Operates from a Single 5-V Supply

Both the logic and receivers operate from a single 5-V rail, making designs much more simple. The line drivers and receivers can operate off the same rail as the host controller or a similar low voltage supply, thus simplifying power structure.



## 7.4 Device Functional Modes

### 7.4.1 Enable and Disable

The receivers implemented in these RS422 devices can be configured using the G and  $\bar{G}$  pins to be enabled or disabled. This allows users to ignore or filter out transmissions as desired.

表 7-1. Function Table (Each Receiver)

DIFFERENTIAL INPUT	ENABLES <sup>(1)</sup>		OUTPUT
	G	$\bar{G}$	
A/B	G	$\bar{G}$	Y
$V_{ID} \geq V_{IT+}$	H	X	H
	X	L	H
$V_{IT} < V_{ID} < V_{IT+}$	H	X	?
	X	L	?
$V_{ID} \leq V_{IT-}$	H	X	L
	X	L	L
X	L	H	Z

(1) H = High level, L = Low level, X = Irrelevant, Z = High impedance (off), ? = Indeterminate

DRAFT  
 TI Confidential – NDA Restrictions

## 8 Application and Implementation

### 注

以下のアプリケーション情報は、TI の製品仕様に含まれるものではなく、TI ではその正確性または完全性を保証いたしません。個々の目的に対する製品の適合性については、お客様の責任で判断していただくこととなります。また、お客様は自身の設計実装を検証しテストすることで、システムの機能を確認する必要があります。

### 8.1 Application Information

When designing a system that uses drivers, receivers, and transceivers that comply with RS-422 or RS-485, proper cable termination is essential for highly reliable applications with reduced reflections in the transmission line. Because RS-422 allows only one driver on the bus, if termination is used, it is placed only at the end of the cable near the last receiver. In general, RS-485 requires termination at both ends of the cable. Factors to consider when determining the type of termination usually are performance requirements of the application and the ever-present factor, cost. The different types of termination techniques discussed are unterminated lines, parallel termination, AC termination, and multipoint termination. Laboratory waveforms for each termination technique (except multipoint termination) illustrate the usefulness and robustness of RS-422 (and, indirectly, RS-485). Similar results can be obtained if 485-compliant devices and termination techniques are used. For laboratory experiments, 100 feet of 100- $\Omega$ , 24-AWG, twisted-pair cable (Bertek) was used. A single driver and receiver, TI AM26C31C and AM26C32C, respectively, were tested at room temperature with a 5-V supply voltage. Two plots per termination technique are shown. In each plot, the top waveform is the driver input and the bottom waveform is the receiver output. To show voltage waveforms related to transmission-line reflections, the first plot shows output waveforms from the driver at the start of the cable; the second plot shows input waveforms to the receiver at the far end of the cable.

### 8.2 Typical Application



図 8-1. Differential Terminated Configuration

#### 8.2.1 Design Requirements

Resistor and capacitor (if used) termination values are shown for each laboratory experiment, but vary from system to system. For example, the termination resistor,  $R_T$ , must be within 20% of the characteristic impedance,  $Z_0$ , of the cable and can vary from about 80  $\Omega$  to 120  $\Omega$ .

#### 8.2.2 Detailed Design Procedure

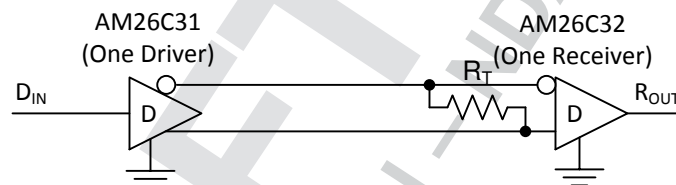
図 8-1 shows a configuration with no termination. Although reflections are present at the receiver inputs at a data signaling rate of 200 kbps with no termination, the RS-422-compliant receiver reads only the input differential voltage and produces a clean signal at the output.

### 8.2.3 Application Curve

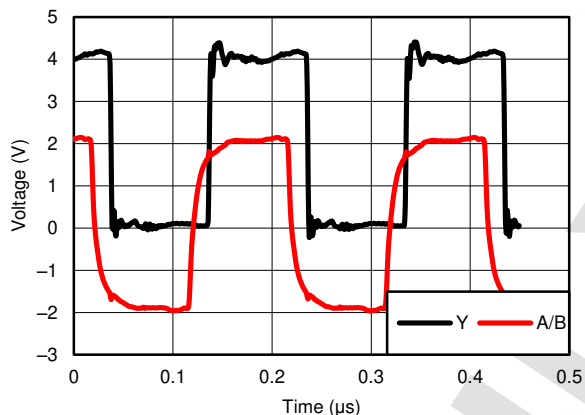

**8-2. Differential 120-Ω Terminated Output Waveforms (Cat 5E Cable)**

### 8.3 Power Supply Recommendations

Place 0.1- $\mu$ F bypass capacitors close to the power-supply pins to reduce errors coupling in from noisy or high impedance power supplies.

### 8.4 Layout

#### 8.4.1 Layout Guidelines

For best operational performance of the device, use good PCB layout practices, including:

- Noise can propagate into analog circuitry through the power pins of the circuit as a whole, as well as the operational amplifier. Bypass capacitors are used to reduce the coupled noise by providing low impedance power sources local to the analog circuitry.
  - Connect low-ESR, 0.1- $\mu$ F ceramic bypass capacitors between each supply pin and ground, placed as close to the device as possible. A single bypass capacitor from V+ to ground is applicable for single supply applications.
- Separate grounding for analog and digital portions of circuitry is one of the simplest and most-effective methods of noise suppression. One or more layers on multilayer PCBs are usually devoted to ground planes. A ground plane helps distribute heat and reduces EMI noise pickup. Make sure to physically separate digital and analog grounds, paying attention to the flow of the ground current.
- To reduce parasitic coupling, run the input traces as far away from the supply or output traces as possible. If it is not possible to keep them separate, it is much better to cross the sensitive trace perpendicular as opposed to in parallel with the noisy trace.
- Place the external components as close to the device as possible. Keeping RF and RG close to the inverting input minimizes parasitic capacitance.
- Keep the length of input traces as short as possible. Always remember that the input traces are the most sensitive part of the circuit.
- Consider a driven, low-impedance guard ring around the critical traces. A guard ring can significantly reduce leakage currents from nearby traces that are at different potentials.

### 8.4.2 Layout Example

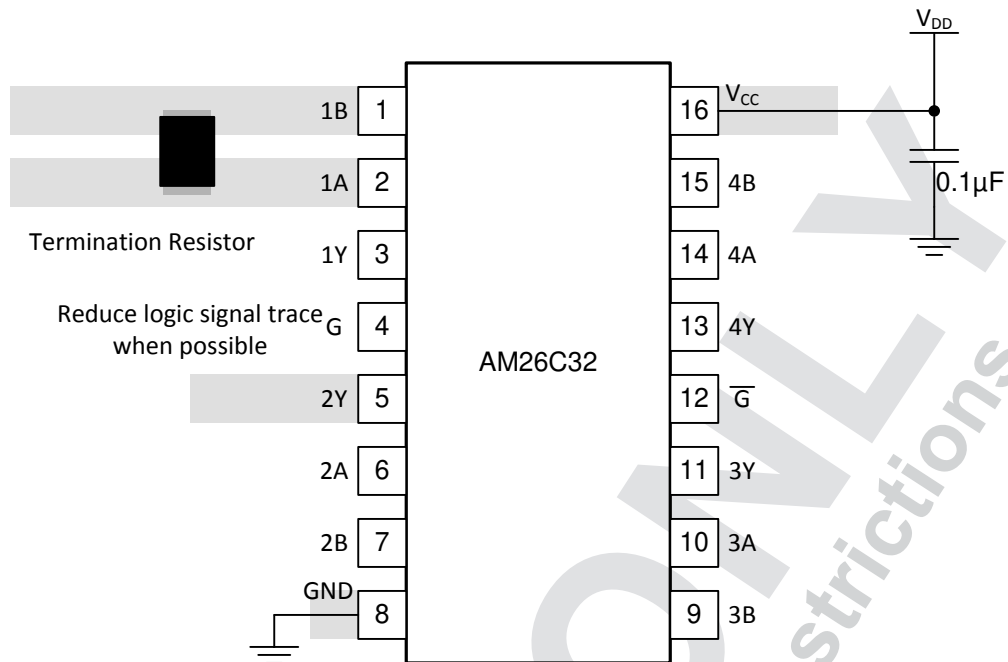

☒ 8-3. Trace Layout on PCB and Recommendations

DRAFT

TI Confidential – NDA Restrictions

## 9 Device and Documentation Support

### 9.1 ドキュメントの更新通知を受け取る方法

ドキュメントの更新についての通知を受け取るには、[ti.com](http://ti.com) のデバイス製品フォルダを開いてください。「更新の通知を受け取る」をクリックして登録すると、変更されたすべての製品情報に関するダイジェストを毎週受け取れます。変更の詳細については、修正されたドキュメントに含まれている改訂履歴をご覧ください。

### 9.2 サポート・リソース

**TI E2E™ サポート・フォーラム**は、エンジニアが検証済みの回答と設計に関するヒントをエキスパートから迅速かつ直接得ることができる場所です。既存の回答を検索したり、独自の質問をしたりすることで、設計に必要な支援を迅速に得ることができます。

リンクされているコンテンツは、該当する貢献者により、現状のまま提供されるものです。これらは TI の仕様を構成するものではなく、必ずしも TI の見解を反映したものではありません。TI の[使用条件](#)を参照してください。

### 9.3 Trademarks

TI E2E™ is a trademark of Texas Instruments.  
すべての商標は、それぞれの所有者に帰属します。

### 9.4 静電気放電に関する注意事項



この IC は、ESD によって破損する可能性があります。テキサス・インスツルメンツは、IC を取り扱う際には常に適切な注意を払うことを推奨します。正しい ESD 対策をとらないと、デバイスを破損するおそれがあります。

ESD による破損は、わずかな性能低下からデバイスの完全な故障まで多岐にわたります。精密な IC の場合、パラメータがわずかに変化するだけで公表されている仕様から外れる可能性があるため、破損が発生しやすくなっています。

### 9.5 用語集

**TI 用語集** この用語集には、用語や略語の一覧および定義が記載されています。

## 10 Revision History

資料番号末尾の英字は改訂を表しています。その改訂履歴は英語版に準じています。

Changes from Revision K (October 2018) to Revision M (October 2023)	Page
• 「製品情報」表を「パッケージ情報」表に変更 .....	1
• Updated the <i>Thermal Information</i> table.....	5
Changes from Revision K (June 2015) to Revision L (October 2018)	Page
• Changed I <sub>I</sub> unit value From: $\mu$ A To: mA in the <i>Electrical Characteristics</i> table.....	5
Changes from Revision J (February 2014) to Revision K (June 2015)	Page
• 「ピン構成および機能」セクション、「ESD 定格」表、「機能説明」セクション、「デバイスの機能モード」セクション、「アプリケーションと実装」セクション、「電源に関する推奨事項」セクション、「レイアウト」セクション、「デバイスおよびドキュメントのサポート」セクション、「メカニカル、パッケージ、および注文情報」セクションを追加 .....	1
Changes from Revision I (September 2004) to Revision J (February 2014)	Page
• 新しいテキサス・インスツルメンツのデータシート・フォーマットにドキュメントを更新 - 仕様変更なし.....	1
• 「注文情報」表を削除. ....	1
• 「特長」を更新 .....	1

## 11 Mechanical, Packaging, and Orderable Information

The following pages include mechanical, packaging, and orderable information. This information is the most current data available for the designated devices. This data is subject to change without notice and revision of this document. For browser-based versions of this data sheet, refer to the left-hand navigation.

**DRAFT ONLY**  
TI Confidential – NDA Restrictions

**PACKAGING INFORMATION**

Orderable Device	Status (1)	Package Type	Package Drawing	Pins	Package Qty	Eco Plan (2)	Lead finish/ Ball material (6)	MSL Peak Temp (3)	Op Temp (°C)	Device Marking (4/5)	Samples
5962-9164001Q2A	ACTIVE	LCCC	FK	20	55	Non-RoHS & Green	SNPB	N / A for Pkg Type	-55 to 125	5962-9164001Q2A AM26C32 MFKB	<a href="#">Samples</a>
5962-9164001QEA	ACTIVE	CDIP	J	16	25	Non-RoHS & Green	SNPB	N / A for Pkg Type	-55 to 125	5962-9164001QE A AM26C32MJB	<a href="#">Samples</a>
5962-9164001QFA	ACTIVE	CFP	W	16	25	Non-RoHS & Green	SNPB	N / A for Pkg Type	-55 to 125	5962-9164001QF A AM26C32MWB	<a href="#">Samples</a>
AM26C32CD	OBSOLETE	SOIC	D	16		TBD	Call TI	Call TI	0 to 70	AM26C32C	
AM26C32CDBR	OBSOLETE	SSOP	DB	16		TBD	Call TI	Call TI		26C32	
AM26C32CDR	OBSOLETE	SOIC	D	16		TBD	Call TI	Call TI	0 to 70	AM26C32C	
AM26C32CN	ACTIVE	PDIP	N	16	25	RoHS & Green	NIPDAU	N / A for Pkg Type	0 to 70	AM26C32CN	<a href="#">Samples</a>
AM26C32CNE4	ACTIVE	PDIP	N	16	25	RoHS & Green	NIPDAU	N / A for Pkg Type	0 to 70	AM26C32CN	<a href="#">Samples</a>
AM26C32CNSR	OBSOLETE	SOP	NS	16		TBD	Call TI	Call TI	0 to 70	26C32	
AM26C32ID	OBSOLETE	SOIC	D	16		TBD	Call TI	Call TI	-40 to 85	AM26C32I	
AM26C32IDBR	ACTIVE	SSOP	DB	16	2000	RoHS & Green	NIPDAU	Level-1-260C-UNLIM	-40 to 85	(26C32, 26C32I)	<a href="#">Samples</a>
AM26C32IDR	ACTIVE	SOIC	D	16	2500	RoHS & Green	NIPDAU	Level-1-260C-UNLIM	-40 to 85	AM26C32I	<a href="#">Samples</a>
AM26C32IDRE4	ACTIVE	SOIC	D	16	2500	RoHS & Green	NIPDAU	Level-1-260C-UNLIM	-40 to 85	AM26C32I	<a href="#">Samples</a>
AM26C32IDRG4	ACTIVE	SOIC	D	16	2500	RoHS & Green	NIPDAU	Level-1-260C-UNLIM	-40 to 85	AM26C32I	<a href="#">Samples</a>
AM26C32IN	ACTIVE	PDIP	N	16	25	RoHS & Green	NIPDAU	N / A for Pkg Type	-40 to 85	AM26C32IN	<a href="#">Samples</a>
AM26C32INSR	ACTIVE	SOP	NS	16	2000	RoHS & Green	NIPDAU	Level-1-260C-UNLIM	-40 to 85	26C32I	<a href="#">Samples</a>
AM26C32IPW	OBSOLETE	TSSOP	PW	16		TBD	Call TI	Call TI	-40 to 85	26C32I	
AM26C32IPWR	ACTIVE	TSSOP	PW	16	2000	RoHS & Green	NIPDAU	Level-1-260C-UNLIM	-40 to 85	26C32I	<a href="#">Samples</a>
AM26C32IPWRG4	ACTIVE	TSSOP	PW	16	2000	RoHS & Green	NIPDAU	Level-1-260C-UNLIM	-40 to 85	26C32I	<a href="#">Samples</a>

Orderable Device	Status (1)	Package Type	Package Drawing	Pins	Package Qty	Eco Plan (2)	Lead finish/ Ball material (6)	MSL Peak Temp (3)	Op Temp (°C)	Device Marking (4/5)	Samples
AM26C32MFKB	ACTIVE	LCCC	FK	20	55	Non-RoHS & Green	SNPB	N / A for Pkg Type	-55 to 125	5962-9164001Q2A AM26C32 MFKB	<a href="#">Samples</a>
AM26C32MJB	ACTIVE	CDIP	J	16	25	Non-RoHS & Green	SNPB	N / A for Pkg Type	-55 to 125	5962-9164001QE A AM26C32MJB	<a href="#">Samples</a>
AM26C32MWB	ACTIVE	CFP	W	16	25	Non-RoHS & Green	SNPB	N / A for Pkg Type	-55 to 125	5962-9164001QF A AM26C32MWB	<a href="#">Samples</a>
AM26C32QD	OBSOLETE	SOIC	D	16		TBD	Call TI	Call TI	-40 to 125	AM26C32Q	
AM26C32QDG4	OBSOLETE	SOIC	D	16		TBD	Call TI	Call TI	-40 to 125	26C32Q	
AM26C32QDR	ACTIVE	SOIC	D	16	2500	RoHS & Green	NIPDAU	Level-1-260C-UNLIM	-40 to 125	AM26C32Q	<a href="#">Samples</a>

(1) The marketing status values are defined as follows:

**ACTIVE:** Product device recommended for new designs.

**LIFEBUY:** TI has announced that the device will be discontinued, and a lifetime-buy period is in effect.

**NRND:** Not recommended for new designs. Device is in production to support existing customers, but TI does not recommend using this part in a new design.

**PREVIEW:** Device has been announced but is not in production. Samples may or may not be available.

**OBSOLETE:** TI has discontinued the production of the device.

(2) **RoHS:** TI defines "RoHS" to mean semiconductor products that are compliant with the current EU RoHS requirements for all 10 RoHS substances, including the requirement that RoHS substance do not exceed 0.1% by weight in homogeneous materials. Where designed to be soldered at high temperatures, "RoHS" products are suitable for use in specified lead-free processes. TI may reference these types of products as "Pb-Free".

**RoHS Exempt:** TI defines "RoHS Exempt" to mean products that contain lead but are compliant with EU RoHS pursuant to a specific EU RoHS exemption.

**Green:** TI defines "Green" to mean the content of Chlorine (Cl) and Bromine (Br) based flame retardants meet JS709B low halogen requirements of <=1000ppm threshold. Antimony trioxide based flame retardants must also meet the <=1000ppm threshold requirement.

(3) MSL, Peak Temp. - The Moisture Sensitivity Level rating according to the JEDEC industry standard classifications, and peak solder temperature.

(4) There may be additional marking, which relates to the logo, the lot trace code information, or the environmental category on the device.

(5) Multiple Device Markings will be inside parentheses. Only one Device Marking contained in parentheses and separated by a "~" will appear on a device. If a line is indented then it is a continuation of the previous line and the two combined represent the entire Device Marking for that device.



<sup>(6)</sup> Lead finish/Ball material - Orderable Devices may have multiple material finish options. Finish options are separated by a vertical ruled line. Lead finish/Ball material values may wrap to two lines if the finish value exceeds the maximum column width.

**Important Information and Disclaimer:**The information provided on this page represents TI's knowledge and belief as of the date that it is provided. TI bases its knowledge and belief on information provided by third parties, and makes no representation or warranty as to the accuracy of such information. Efforts are underway to better integrate information from third parties. TI has taken and continues to take reasonable steps to provide representative and accurate information but may not have conducted destructive testing or chemical analysis on incoming materials and chemicals. TI and TI suppliers consider certain information to be proprietary, and thus CAS numbers and other limited information may not be available for release.

In no event shall TI's liability arising out of such information exceed the total purchase price of the TI part(s) at issue in this document sold by TI to Customer on an annual basis.

**OTHER QUALIFIED VERSIONS OF AM26C32, AM26C32M :**

- Catalog : [AM26C32](#)
  
- Enhanced Product : [AM26C32-EP](#), [AM26C32-EP](#)
  
- Military : [AM26C32M](#)

NOTE: Qualified Version Definitions:

- Catalog - TI's standard catalog product
  
- Enhanced Product - Supports Defense, Aerospace and Medical Applications
  
- Military - QML certified for Military and Defense Applications

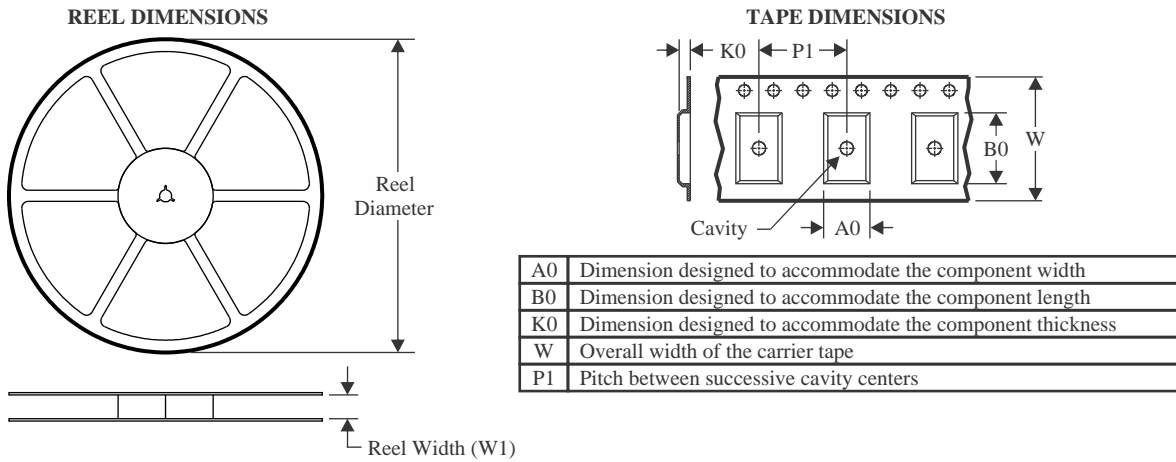
**TAPE AND REEL INFORMATION**

**QUADRANT ASSIGNMENTS FOR PIN 1 ORIENTATION IN TAPE**

\*All dimensions are nominal

Device	Package Type	Package Drawing	Pins	SPQ	Reel Diameter (mm)	Reel Width W1 (mm)	A0 (mm)	B0 (mm)	K0 (mm)	P1 (mm)	W (mm)	Pin1 Quadrant
AM26C32IDBR	SSOP	DB	16	2000	330.0	16.4	8.35	6.6	2.4	12.0	16.0	Q1
AM26C32IDBR	SSOP	DB	16	2000	330.0	16.4	8.35	6.6	2.4	12.0	16.0	Q1
AM26C32IDR	SOIC	D	16	2500	330.0	16.4	6.5	10.3	2.1	8.0	16.0	Q1
AM26C32INSR	SOP	NS	16	2000	330.0	16.4	8.2	10.5	2.5	12.0	16.0	Q1
AM26C32INSR	SOP	NS	16	2000	330.0	16.4	8.2	10.5	2.5	12.0	16.0	Q1
AM26C32IPWR	TSSOP	PW	16	2000	330.0	12.4	6.9	5.6	1.6	8.0	12.0	Q1
AM26C32QDR	SOIC	D	16	2500	330.0	16.4	6.5	10.3	2.1	8.0	16.0	Q1

**TAPE AND REEL BOX DIMENSIONS**

\*All dimensions are nominal

Device	Package Type	Package Drawing	Pins	SPQ	Length (mm)	Width (mm)	Height (mm)
AM26C32IDBR	SSOP	DB	16	2000	356.0	356.0	35.0
AM26C32IDBR	SSOP	DB	16	2000	353.0	353.0	32.0
AM26C32IDR	SOIC	D	16	2500	353.0	353.0	32.0
AM26C32INSR	SOP	NS	16	2000	353.0	353.0	32.0
AM26C32INSR	SOP	NS	16	2000	367.0	367.0	38.0
AM26C32IPWR	TSSOP	PW	16	2000	367.0	367.0	35.0
AM26C32QDR	SOIC	D	16	2500	353.0	353.0	32.0

**TUBE**

\*All dimensions are nominal

Device	Package Name	Package Type	Pins	SPQ	L (mm)	W (mm)	T (μm)	B (mm)
5962-9164001Q2A	FK	LCCC	20	55	506.98	12.06	2030	NA
5962-9164001QFA	W	CFP	16	25	506.98	26.16	6220	NA
AM26C32CN	N	PDIP	16	25	506	13.97	11230	4.32
AM26C32CN	N	PDIP	16	25	506	13.97	11230	4.32
AM26C32CNE4	N	PDIP	16	25	506	13.97	11230	4.32
AM26C32CNE4	N	PDIP	16	25	506	13.97	11230	4.32
AM26C32IN	N	PDIP	16	25	506	13.97	11230	4.32
AM26C32MFKB	FK	LCCC	20	55	506.98	12.06	2030	NA
AM26C32MWB	W	CFP	16	25	506.98	26.16	6220	NA

W (R-GDFP-F16)

CERAMIC DUAL FLATPACK

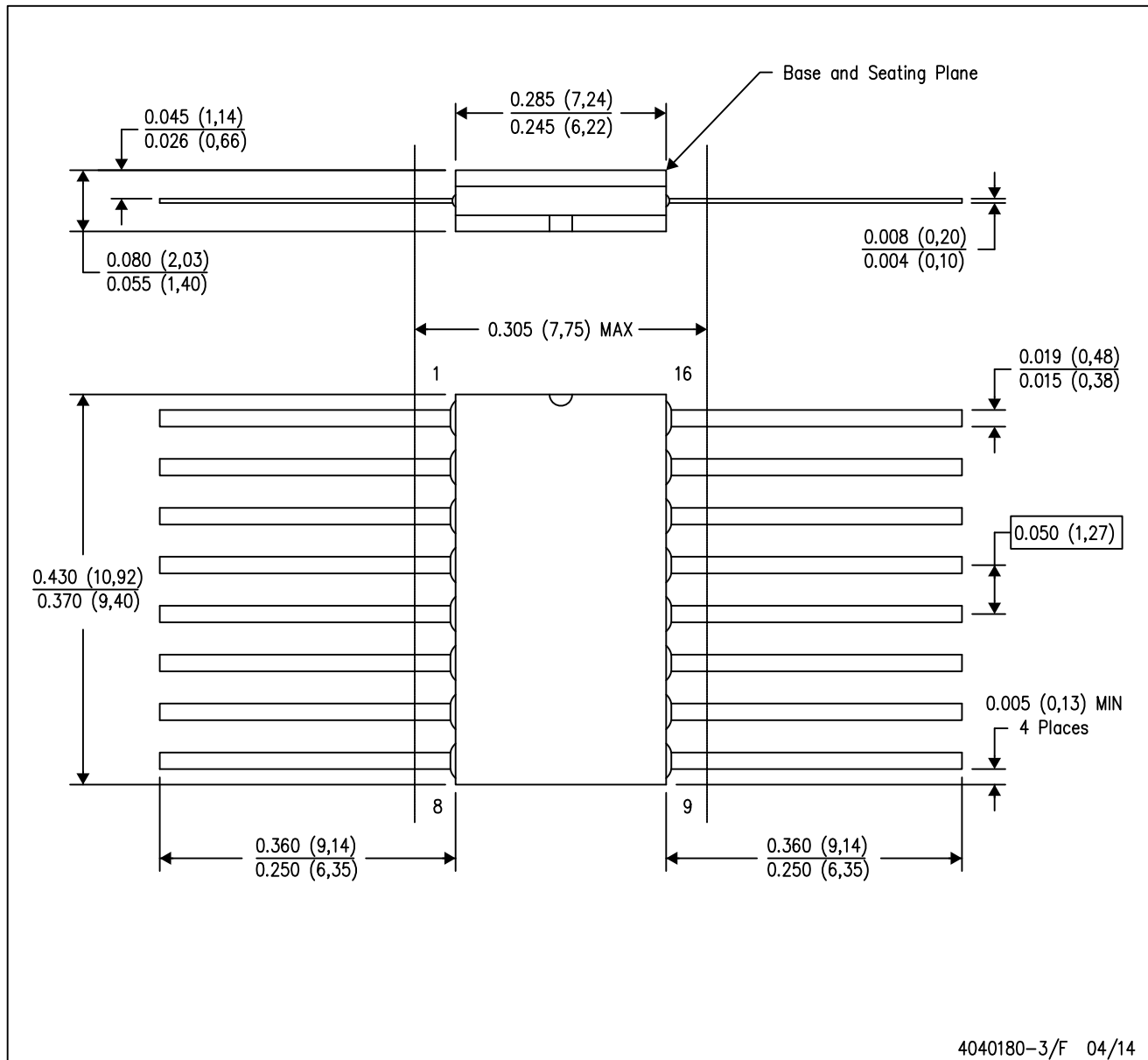

- NOTES:
- A. All linear dimensions are in inches (millimeters).
  - B. This drawing is subject to change without notice.
  - C. This package can be hermetically sealed with a ceramic lid using glass frit.
  - D. Index point is provided on cap for terminal identification only.
  - E. Falls within MIL STD 1835 GDFP2-F16

## GENERIC PACKAGE VIEW

**FK 20**

**LCCC - 2.03 mm max height**

8.89 x 8.89, 1.27 mm pitch

LEADLESS CERAMIC CHIP CARRIER

This image is a representation of the package family, actual package may vary.  
Refer to the product data sheet for package details.

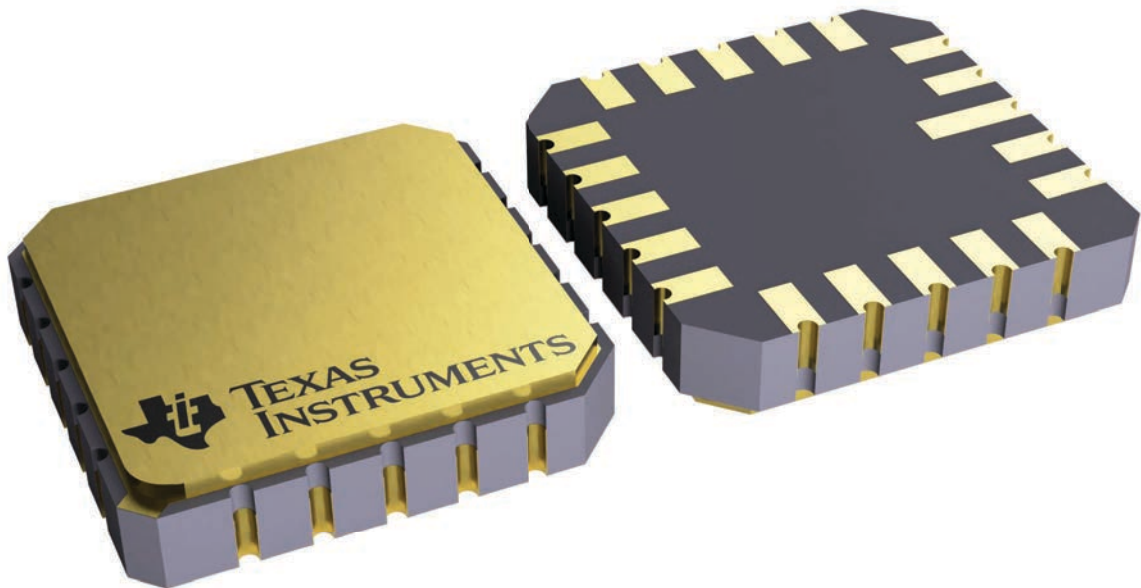

4229370VA\



N (R-PDIP-T\*\*)

PLASTIC DUAL-IN-LINE PACKAGE

16 PINS SHOWN



- NOTES:
- A. All linear dimensions are in inches (millimeters).
  - B. This drawing is subject to change without notice.
  - Falls within JEDEC MS-001, except 18 and 20 pin minimum body length (Dim A).
  - The 20 pin end lead shoulder width is a vendor option, either half or full width.





# PACKAGE OUTLINE

## NS0016A

### SOP - 2.00 mm max height

SOP

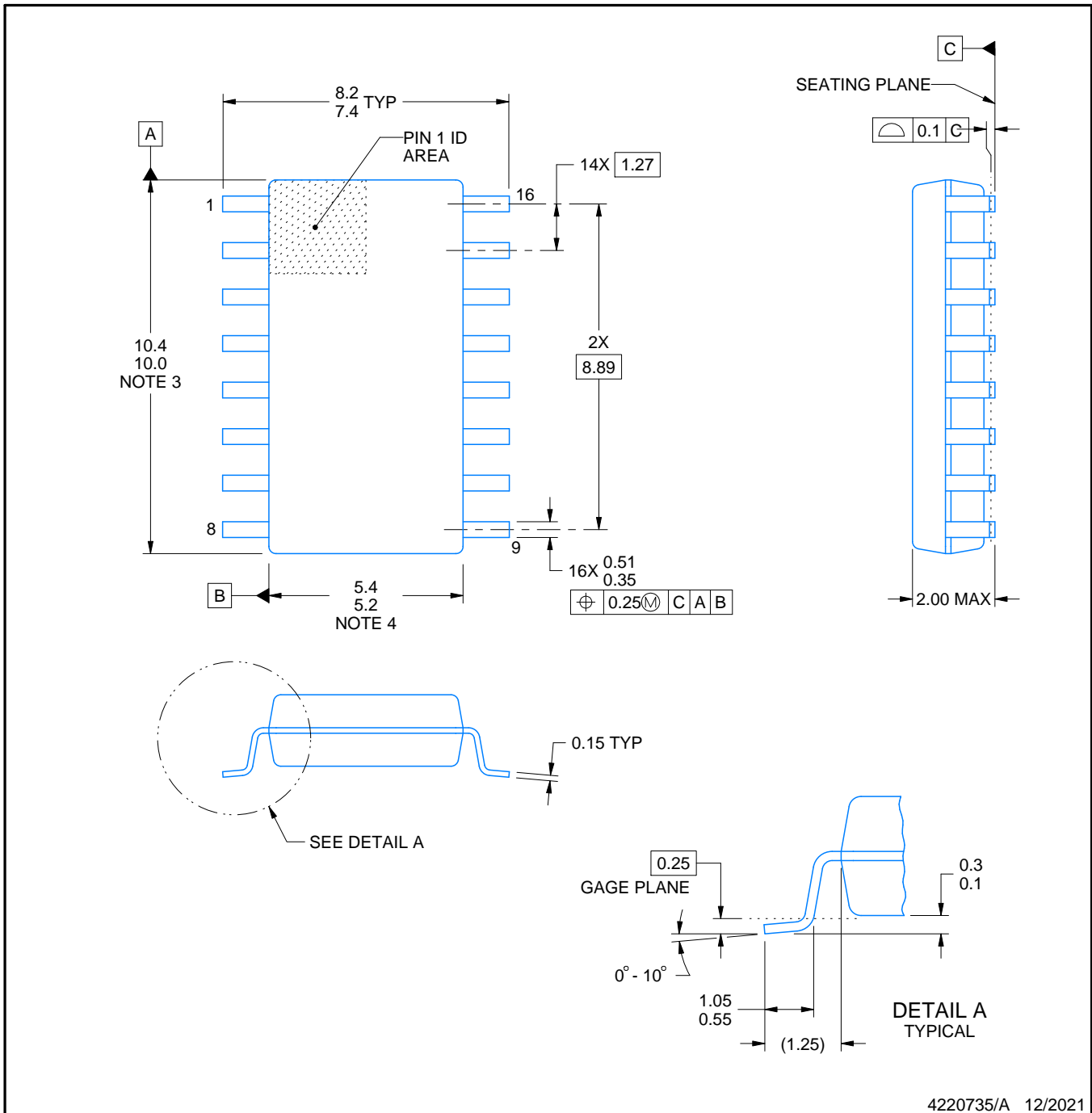

4220735/A 12/2021

#### NOTES:

- All linear dimensions are in millimeters. Dimensions in parenthesis are for reference only. Dimensioning and tolerancing per ASME Y14.5M.
- This drawing is subject to change without notice.
- This dimension does not include mold flash, protrusions, or gate burrs. Mold flash, protrusions, or gate burrs shall not exceed 0.15 mm, per side.
- This dimension does not include interlead flash. Interlead flash shall not exceed 0.25 mm, per side.



# EXAMPLE STENCIL DESIGN

NS0016A

SOP - 2.00 mm max height

SOP

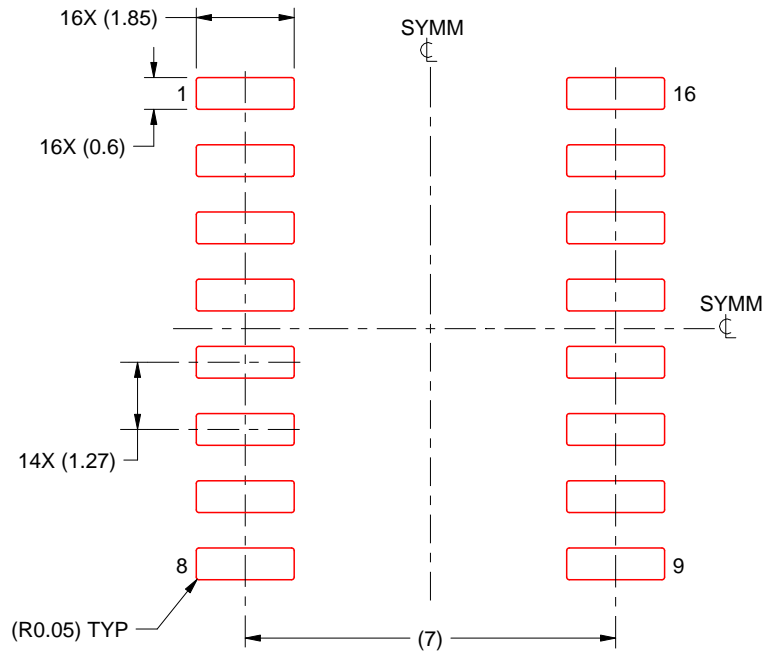

SOLDER PASTE EXAMPLE  
BASED ON 0.125 mm THICK STENCIL  
SCALE:7X

4220735/A 12/2021



NOTES: (continued)

7. Laser cutting apertures with trapezoidal walls and rounded corners may offer better paste release. IPC-7525 may have alternate design recommendations.
8. Board assembly site may have different recommendations for stencil design.

D (R-PDSO-G16)

PLASTIC SMALL OUTLINE



- NOTES:
- A. All linear dimensions are in inches (millimeters).
  - B. This drawing is subject to change without notice.
  -  Body length does not include mold flash, protrusions, or gate burrs. Mold flash, protrusions, or gate burrs shall not exceed 0.006 (0,15) each side.
  -  Body width does not include interlead flash. Interlead flash shall not exceed 0.017 (0,43) each side.
  - E. Reference JEDEC MS-012 variation AC.



4220204/A 02/2017

NOTES:

1. All linear dimensions are in millimeters. Any dimensions in parenthesis are for reference only. Dimensioning and tolerancing per ASME Y14.5M.
2. This drawing is subject to change without notice.
3. This dimension does not include mold flash, protrusions, or gate burrs. Mold flash, protrusions, or gate burrs shall not exceed 0.15 mm per side.
4. This dimension does not include interlead flash. Interlead flash shall not exceed 0.25 mm per side.
5. Reference JEDEC registration MO-153.

# EXAMPLE BOARD LAYOUT

PW0016A

TSSOP - 1.2 mm max height

SMALL OUTLINE PACKAGE



LAND PATTERN EXAMPLE  
EXPOSED METAL SHOWN  
SCALE: 10X



4220204/A 02/2017

NOTES: (continued)

- 6. Publication IPC-7351 may have alternate designs.
- 7. Solder mask tolerances between and around signal pads can vary based on board fabrication site.

# EXAMPLE STENCIL DESIGN

PW0016A

TSSOP - 1.2 mm max height

SMALL OUTLINE PACKAGE



SOLDER PASTE EXAMPLE  
BASED ON 0.125 mm THICK STENCIL  
SCALE: 10X

4220204/A 02/2017

NOTES: (continued)

8. Laser cutting apertures with trapezoidal walls and rounded corners may offer better paste release. IPC-7525 may have alternate design recommendations.
9. Board assembly site may have different recommendations for stencil design.

# DB0016A



# PACKAGE OUTLINE

## SSOP - 2 mm max height

SMALL OUTLINE PACKAGE

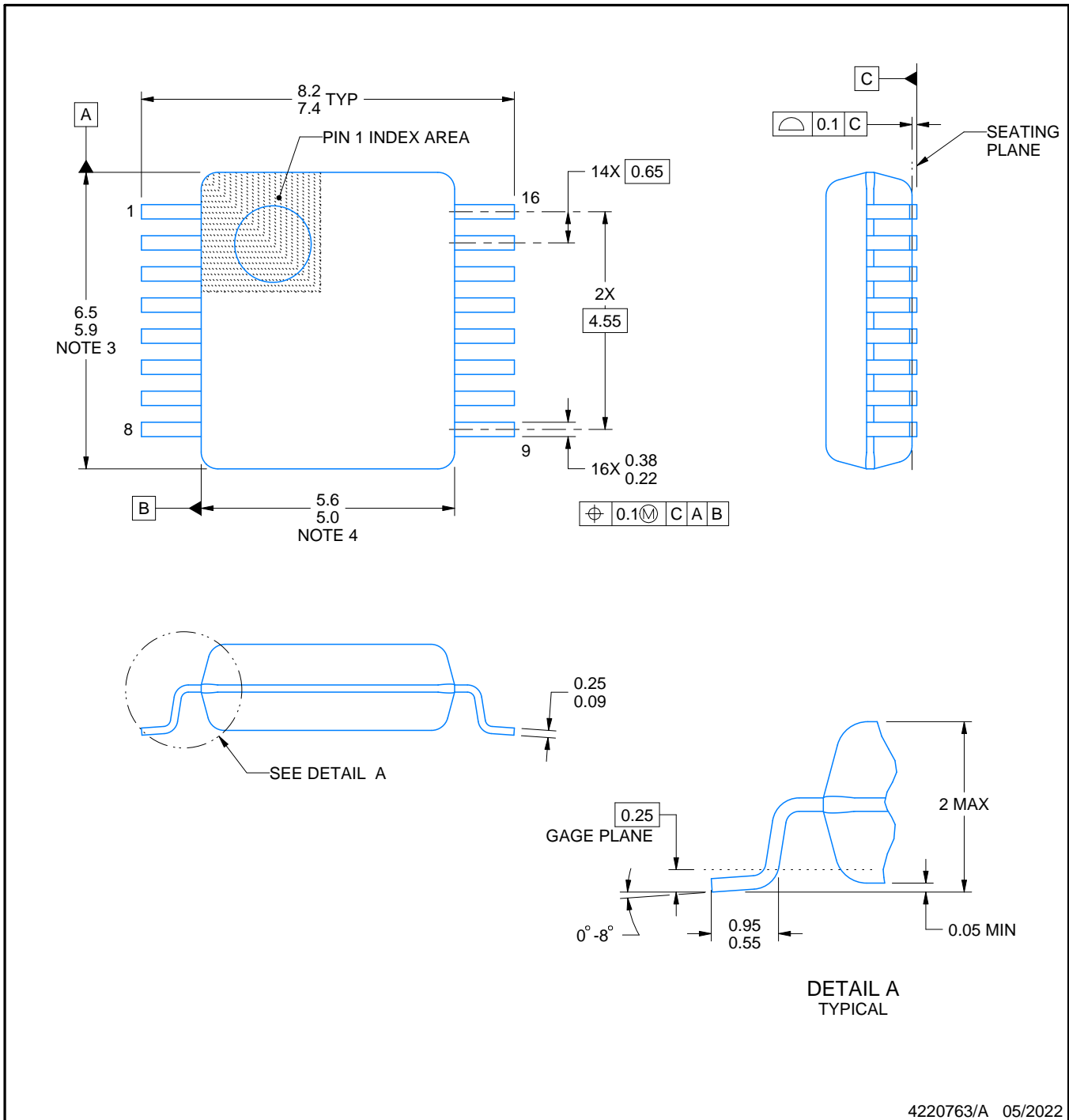

4220763/A 05/2022

### NOTES:

- All linear dimensions are in millimeters. Any dimensions in parenthesis are for reference only. Dimensioning and tolerancing per ASME Y14.5M.
- This drawing is subject to change without notice.
- This dimension does not include mold flash, protrusions, or gate burrs. Mold flash, protrusions, or gate burrs shall not exceed 0.15 mm per side.
- Reference JEDEC registration MO-150.



# EXAMPLE BOARD LAYOUT

DB0016A

SSOP - 2 mm max height

SMALL OUTLINE PACKAGE

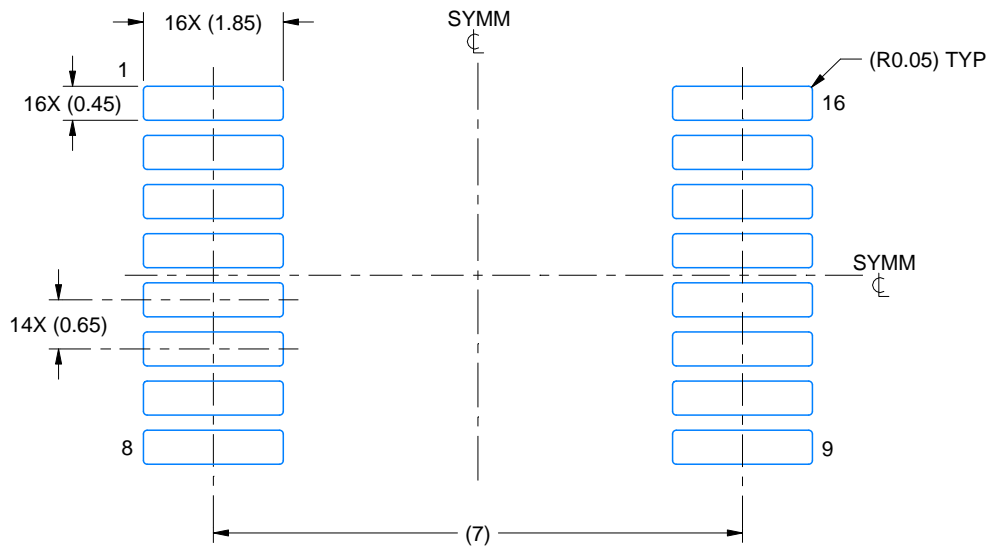

LAND PATTERN EXAMPLE  
EXPOSED METAL SHOWN  
SCALE: 10X

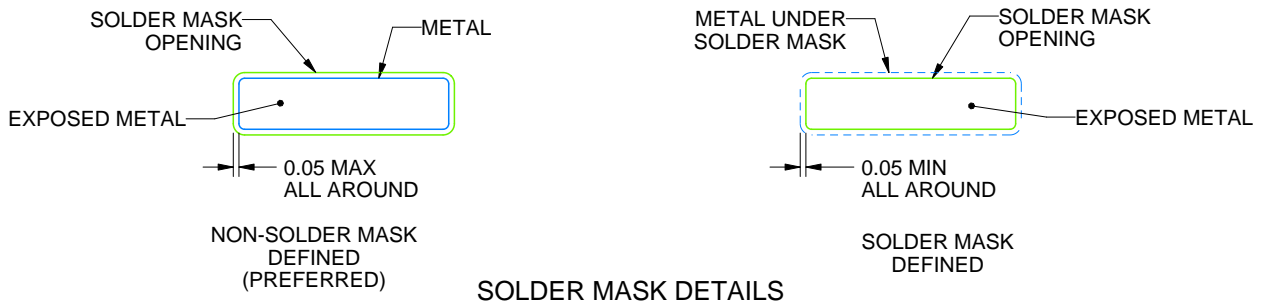

4220763/A 05/2022

NOTES: (continued)

5. Publication IPC-7351 may have alternate designs.
6. Solder mask tolerances between and around signal pads can vary based on board fabrication site.

# EXAMPLE STENCIL DESIGN

DB0016A

SSOP - 2 mm max height

SMALL OUTLINE PACKAGE

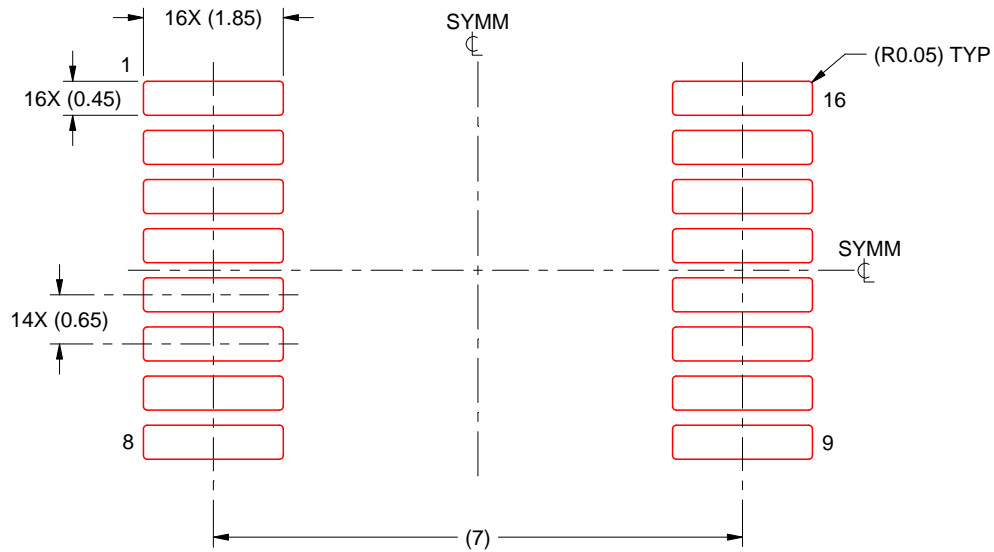

SOLDER PASTE EXAMPLE  
BASED ON 0.125 mm THICK STENCIL  
SCALE: 10X

4220763/A 05/2022

NOTES: (continued)

7. Laser cutting apertures with trapezoidal walls and rounded corners may offer better paste release. IPC-7525 may have alternate design recommendations.
8. Board assembly site may have different recommendations for stencil design.

# MECHANICAL DATA

NS (R-PDSO-G\*\*)

PLASTIC SMALL-OUTLINE PACKAGE

14-PINS SHOWN



- NOTES:
- A. All linear dimensions are in millimeters.
  - B. This drawing is subject to change without notice.
  - C. Body dimensions do not include mold flash or protrusion, not to exceed 0,15.

## 重要なお知らせと免責事項

TI は、技術データと信頼性データ (データシートを含みます)、設計リソース (リファレンス・デザインを含みます)、アプリケーションや設計に関する各種アドバイス、Web ツール、安全性情報、その他のリソースを、欠陥が存在する可能性のある「現状のまま」提供しており、商品性および特定目的に対する適合性の黙示保証、第三者の知的財産権の非侵害保証を含むいかなる保証も、明示的または黙示的にかかわらず拒否します。

これらのリソースは、TI 製品を使用する設計の経験を積んだ開発者への提供を意図したものです。(1) お客様のアプリケーションに適した TI 製品の選定、(2) お客様のアプリケーションの設計、検証、試験、(3) お客様のアプリケーションに該当する各種規格や、その他のあらゆる安全性、セキュリティ、規制、または他の要件への確実な適合に関する責任を、お客様のみが単独で負うものとし、

上記の各種リソースは、予告なく変更される可能性があります。これらのリソースは、リソースで説明されている TI 製品を使用するアプリケーションの開発の目的でのみ、TI はその使用をお客様に許諾します。これらのリソースに関して、他の目的で複製することや掲載することは禁止されています。TI や第三者の知的財産権のライセンスが付与されている訳ではありません。お客様は、これらのリソースを自身で使用した結果発生するあらゆる申し立て、損害、費用、損失、責任について、TI およびその代理人を完全に補償するものとし、TI は一切の責任を拒否します。

TI の製品は、[TI の販売条件](#)、または [ti.com](#) やかかる TI 製品の関連資料などのいずれかを通じて提供する適用可能な条項の下で提供されています。TI がこれらのリソースを提供することは、適用される TI の保証または他の保証の放棄の拡大や変更を意味するものではありません。

お客様がいかなる追加条項または代替条項を提案した場合でも、TI はそれらに異議を唱え、拒否します。

郵送先住所 : Texas Instruments, Post Office Box 655303, Dallas, Texas 75265  
Copyright © 2024, Texas Instruments Incorporated