

CDx4HC4511、CD74HCT4511 BCD から 7 セグメントへのラッチ / デコーダ / ドライバ

1 特長

- 2V~6V の V_{CC} で動作 ('HC4511)
- 4.5V~5.5V の V_{CC} で動作 (CD74HCT4511)
- 高い出力ソース能力
 - 4.5V で 7.5mA (CD74HCT4511)
 - 6V で 10mA ('HC4511)
- BCD コード・ストレージ用の入力ラッチ
- ランプ・テストおよびブランキング機能
- 平衡な伝搬遅延と遷移時間
- LSTTL ロジック IC と比べて消費電力を大幅に削減
- 'HC4511
 - 高いノイズ耐性、 $V_{CC} = 5V$ 時に V_{CC} に対して N_{IL} または $N_{IH} = 30\%$
- CD74HCT4511
 - LSTTL 入力ロジックと直接互換、 $V_{IL} = 0.8V$ (最大値)、 $V_{IH} = 2V$ (最小値)
 - CMOS 入力互換、 V_{OL} 、 V_{OH} で $I_L \leq 1\mu A$

2 概要

CD54HC4511、CD74HC4511、CD74HCT4511 は、BCD から 7 セグメントへのラッチ / デコーダ / ドライバで、4 つのアドレス入力 ($D_0 \sim D_3$) と、アクティブ Low のブランキング (\overline{BL}) 入力、ランプ・テスト (\overline{LT}) 入力、ラッチ・イネーブル (\overline{LE}) 入力を搭載しており、ラッチ・イネーブル入力が High のときは BCD 入力をラッチに保存できます。 \overline{LE} が Low のときはラッチがディセーブルで、出力が BCD 入力に対して透過的になります。

製品情報

部品番号	パッケージ (1)	本体サイズ (公称)
CD54HC4511	J (CDIP, 16)	24.38mm × 6.92mm
CD74HC4511	N (PDIP, 16)	19.31mm × 6.35mm
	D (SOIC, 16)	9.90mm × 3.90mm
	PW (TSSOP, 16)	5.00mm × 4.40mm
CD74HCT4511	N (PDIP, 16)	19.31mm × 6.35mm

(1) 利用可能なパッケージについては、このデータシートの末尾にある注文情報を参照してください。

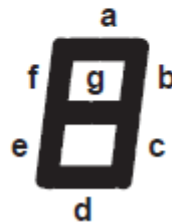
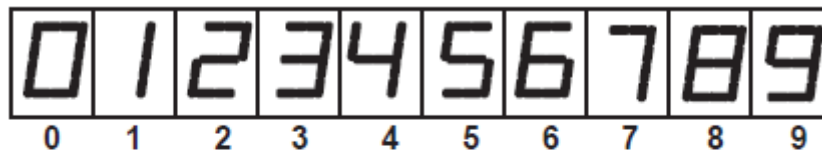

ディスプレイ



Table of Contents

1 特長	1	6 Parameter Measurement Information	8
2 概要	1	7 Detailed Description	10
3 Revision History	2	7.1 Overview.....	10
4 Pin Configuration and Functions	3	7.2 Functional Block Diagram.....	10
5 Specifications	4	7.3 Device Functional Modes.....	10
5.1 Absolute Maximum Ratings.....	4	8 Power Supply Recommendations	11
5.2 Recommended Operating Conditions for 'HC4511 ⁽¹⁾	4	9 Layout	11
5.3 Recommended Operating Conditions for CD74HCT4511 ⁽¹⁾	4	9.1 Layout Guidelines.....	11
5.4 Thermal Information.....	5	10 Device and Documentation Support	12
5.5 'HC4511 Electrical Characteristics.....	5	10.1 Receiving Notification of Documentation Updates..	12
5.6 CD74HCT4511 Electrical Characteristics.....	5	10.2 サポート・リソース.....	12
5.7 'HC4511 Timing Requirements.....	6	10.3 Trademarks.....	12
5.8 Switching Characteristics.....	6	10.4 Electrostatic Discharge Caution.....	12
5.9 CD74HCT4511 Timing Requirements.....	7	10.5 Glossary.....	12
5.10 CD74HCT4511 Switching Characteristics.....	7	11 Mechanical, Packaging, and Orderable Information	12
5.11 Operating Characteristics.....	7	11.1 Tape and Reel Information.....	13
		11.2 Mechanical Data.....	14

3 Revision History

資料番号末尾の英字は改訂を表しています。その改訂履歴は英語版に準じています。

Changes from Revision D (October 2003) to Revision E (August 2022)	Page
• 最新のデータシート規格を反映するように、文書全体の採番、書式設定、表、図、相互参照を更新.....	1

4 Pin Configuration and Functions

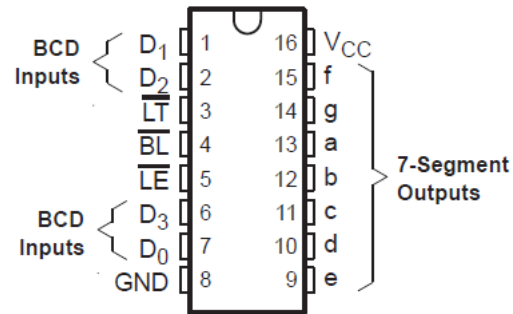

J, N, D, PW package
16-Pin CDIP, PDIP, SOIC, TSSOP
Top View

5 Specifications

5.1 Absolute Maximum Ratings

over operating free-air temperature (unless otherwise noted)⁽¹⁾

		MIN	MAX	UNIT
V _{CC}	Supply voltage	- 0.5	7	V
I _{IK}	Input diode current	V _I < - 0.5 V or V _I > V _{CC} + 0.5 V ⁽¹⁾		±20 mA
I _{OK}	Output diode current	V _O < - 0.5 V or V _O > V _{CC} + 0.5 V ⁽¹⁾		±20 mA
I _O	Output source or sink current per output pin	V _O = 0 to V _{CC}		±25 mA
	Continuous current through V _{CC} or GND			±50 mA
T _J	Junction temperature			150 °C
T _{stg}	Storage temperature range	- 65	150	°C
	Lead temperature (During Soldering)	At distance 1/16 ± 1/32 in (1.59 ± 0.79 mm) from case for 10 s maximum		265 °C
		Unit inserted into a PC board (minimum thickness 1/16 in, 1.59 mm) (with solder contacting lead tips only)		300 °C

- (1) Stresses beyond those listed under “absolute maximum ratings” may cause permanent damage to the device. These are stress ratings only, and functional operation of the device at these or any other conditions beyond those indicated under “recommended operating conditions” is not implied. Exposure to absolute-maximum-rated conditions for extended periods may affect device reliability

5.2 Recommended Operating Conditions for 'HC4511⁽¹⁾

		T _A = 25°C		T _A = - 55°C to 125°C		T _A = - 40°C to 85°C		UNIT
		MIN	NOM	MAX	MIN	NOM	MAX	
V _{CC}	Supply voltage	2	6	2	6	2	6	V
V _{IH}	High-level input voltage	V _{CC} = 2 V		1.5	1.5	1.5		V
		V _{CC} = 4.5 V		3.15	3.15	3.15		
		V _{CC} = 6 V		4.2	4.2	4.2		
V _{IL}	Low-level input voltage	V _{CC} = 2 V			0.5	0.5		V
		V _{CC} = 4.5 V			1.35	1.35		
		V _{CC} = 6 V			1.8	1.8		
V _I	Input voltage	0	V _{CC}	0	V _{CC}	0	V _{CC}	V
V _O	Output voltage	0	V _{CC}	0	V _{CC}	0	V _{CC}	V
t _t	Input transition rise/fall time	V _{CC} = 2 V			1000	1000		ns
		V _{CC} = 4.5 V			500	500		
		V _{CC} = 6 V			400	400		

- (1) All unused inputs of the device must be held at V_{CC} or GND to ensure proper device operation. Refer to the TI application report Implications of Slow or Floating SMOS Inputs, literature number SCBA004.

5.3 Recommended Operating Conditions for CD74HCT4511⁽¹⁾

		T _A = - 55°C to 125°C		T _A = - 55°C to 125°C		T _A = - 40°C to 85°C		UNIT
		MIN	MAX	MIN	MAX	MIN	MAX	
V _{CC}	Supply Voltage	4.5	5.5	4.5	5.5	4.5	5.5	V
V _{IH}	High-level input voltage	2		2		2		V
V _{IL}	Low-level input voltage		0.8		0.8		0.8	
V _I	Input voltage		V _{CC}		V _{CC}		V _{CC}	V
V _O	Output voltage		V _{CC}		V _{CC}		V _{CC}	V

5.3 Recommended Operating Conditions for CD74HCT4511⁽¹⁾ (continued)

		T _A = – 55°C to 125°C		T _A = – 55°C to 125°C		T _A = – 40°C to 85°C		UNIT
		MIN	MAX	MIN	MAX	MIN	MAX	
t _t	Input transition (rise and fall) time	500		500		500		ns

- (1) All unused inputs of the device must be held at V_{CC} or GND to ensure proper device operation. Refer to the TI application report Implications of Slow or Floating SMOS Inputs, literature number [SCBA004](#).

5.4 Thermal Information

THERMAL METRIC ⁽¹⁾		D (SOIC)	N (PDIP)	PW (TSSOP)	UNIT
		16 PINS	16 PINS	16 PINS	
R _{θJA}	Package thermal impedance	67	73	108	°C/W

- (1) For more information about traditional and new thermal metrics, see the [Semiconductor and IC package thermal metrics](#) application report.

5.5 'HC4511 Electrical Characteristics

over recommended operating free-air temperature range (unless otherwise noted)

PARAMETER	TEST CONDITIONS	V _{CC}	T _A = 25°C		T _A = – 55°C to 125°C		T _A = – 40°C to 85°C		UNIT	
			MIN	MAX	MIN	MAX	MIN	MAX		
V _{OH} High level output voltage	V _I = V _{IH} or V _{IL}	I _{OH} = –20 μA	2 V	1.9	1.9	1.9			V	
			4.5 V	4.4	4.4	4.4				
			6 V	5.9	5.9	5.9				
			I _{OH} = –4 mA	4.5 V	3.98	3.7	3.84			
			I _{OH} = –5.2 mA	6 V	5.48	5.2	5.34			
V _{OL} Low level output voltage	V _I = V _{IH} or V _{IL}	I _{OL} = 20 μA	2 V		0.1	0.1	0.1		V	
			4.5 V		0.1	0.1	0.1			
			6 V		0.1	0.1	0.1			
			I _{OL} = 4 mA	4.5 V	0.26	0.4	0.33			
			I _{OL} = 5.2 mA	6 V	0.26	0.4	0.33			
I _I Input leakage current V	V _I = V _{CC} or 0	6 V	±0.1		±1		±1		μA	
I _{CC} Supply current	V _I = V _{CC} or 0, I _O = 0	6 V	8		160		80		μA	
C _i Input Capacitance		2 V to 6 V	10		10		10		pF	

5.6 CD74HCT4511 Electrical Characteristics

over recommended operating free-air temperature range (unless otherwise noted)

PARAMETER	TEST CONDITIONS	V _{CC}	T _A = 25°C			T _A = – 55°C to 125°C		T _A = – 40°C to 85°C		UNIT
			MIN	TYP	MAX	MIN	MAX	MIN	MAX	
V _{OH} High level output voltage	V _I = V _{IH} or V _{IL}	I _{OH} = –20 μA	4.4			4.4		4.4		V
			I _{OH} = –4 mA	3.98			3.7		3.84	
V _{OL} Low level output voltage	V _I = V _{IH} or V _{IL}	I _{OL} = 20 μA			0.1			0.1		V
			I _{OL} = 4 mA			0.26		0.4	0.33	
I _I Input leakage current V	V _I = V _{CC} to GND	5.5 V	±0.1			±1		±1		μA
I _{CC} Supply current	V _I = V _{CC} or 0, I _O = 0	5.5 V	8			160		80		μA
ΔI _{CC} ⁽¹⁾ Supply-Current Change	LT, LE inputs held at V _{CC} – 2.1 V	4.5 V to 5.5 V	100	540		735		675		μA
	BL, Dn inputs held at V _{CC} – 2.1 V		100	108		147		135		

5.6 CD74HCT4511 Electrical Characteristics (continued)

over recommended operating free-air temperature range (unless otherwise noted)

PARAMETER	TEST CONDITIONS	V _{CC}	T _A = 25°C			T _A = -55°C to 125°C		T _A = -40°C to 85°C		UNIT
			MIN	TYP	MAX	MIN	MAX	MIN	MAX	
C _i Input Capacitance					10		10		10	pF

- (1) Additional supply current per input pin, TTL inputs high, 1 unit load. For dual-supply systems, theoretical worst-case (V_I = 2.4 V, V_{CC} = 5.5 V) specification is 1.8 mA.

5.7 'HC4511 Timing Requirements

	V _{CC}	T _A = 25°C		T _A = -55°C to 125°C		T _A = -40°C to 85°C		UNIT
		MIN	MAX	MIN	MAX	MIN	MAX	
t _w	2 V	80		120		100		ns
	4.5 V	16		24		20		
	6 V	14		20		17		
t _{su}	2 V	60		90		75		ns
	4.5 V	12		18		15		
	6 V	10		15		13		
t _h	2 V	3		3		3		ns
	4.5 V	3		3		3		
	6 V	3		3		3		

5.8 Switching Characteristics

PARAMETER	FROM (INPUT)	TO (OUTPUT)	LOAD CAPACITANCE	V _{CC}	T _A = 25°C			T _A = -55°C TO 125°C		T _A = -40°C TO 85°C		UNIT	
					MIN	TYP	MAX	MIN	MAX	MIN	MAX		
t _{pd}	D _n	Output	C _L = 50 pF	2 V			300		450		375	ns	
				4.5 V			60		90		75		
				6 V			51		77		64		
			C _L = 15 pF	5 V		25							
				C _L = 50 pF	2 V			270		405			340
					4.5 V			54		81			68
	6 V				46		69		58				
	C _L = 15 pF	C _L = 50 pF	2 V			220		330		275			
			4.5 V			44		66		55			
			6 V			37		56		47			
		C _L = 15 pF	5 V		18								
			C _L = 50 pF	2 V			160		240		200		
4.5 V						32		48		40			
6 V				27		41		34					
C _L = 15 pF	5 V		13										
	Any	C _L = 50 pF	2 V			75		110		95			
			4.5 V			15		22		19			
6 V					13		19		16				

5.9 CD74HCT4511 Timing Requirements

		T _A = 25°C		T _A = – 55°C TO 125°C		T _A = – 40°C TO 85°C		UNIT
		MIN	MAX	MIN	MAX	MIN	MAX	
t _w	Pulse duration, \overline{LE} low	16		24		20		ns
t _{su}	Setup time, BCD inputs before \overline{LE} ↑	16		24		20		ns
t _h	Hold time, BCD inputs before \overline{LE} ↑	5		5		5		ns

over operating free-air temperature range (unless otherwise noted)

5.10 CD74HCT4511 Switching Characteristics

PARAMETER	FROM (INPUT)	TO (OUTPUT)	LOAD CAPACITANCE	V _{CC}	T _A = 25°C			T _A = – 55°C to 125°C		T _A = – 40°C to 85°C		UNIT
					MIN	TYP	MAX	MIN	MAX	MIN	MAX	
t _{pd}	D _n	Output	C _L = 50 pF	4.5 V			60		90		75	ns
			C _L = 15 pF	5 V		25						
	\overline{LE}	Output	C _L = 50 pF	4.5 V			54		81		68	
			C _L = 15 pF	5 V		23						
	\overline{BL}	Output	C _L = 50 pF	4.5 V			44		66		55	
			C _L = 15 pF	5 V		18						
\overline{LT}	Output	C _L = 50 pF	4.5 V			33		50		41		
		C _L = 15 pF	5 V		13							
t _t		Any	C _L = 50 pF	4.5 V			15		22		19	ns

5.11 Operating Characteristics

PARAMETER ⁽¹⁾			TYP	UNIT
C _{pd}	Power dissipation capacitance	'HC4511	114	pF
		CD74HCT4511	110	

(1) C_{pd} is used to determine the dynamic power consumption, per package.

$$P_D = C_{pd} V_{CC}^2 f_i + \sum C_L V_{CC}^2 f_o \text{ where:}$$

f_i = input frequency

f_o = output frequency

C_L = output load capacitance

V_{CC} = supply voltage

6 Parameter Measurement Information

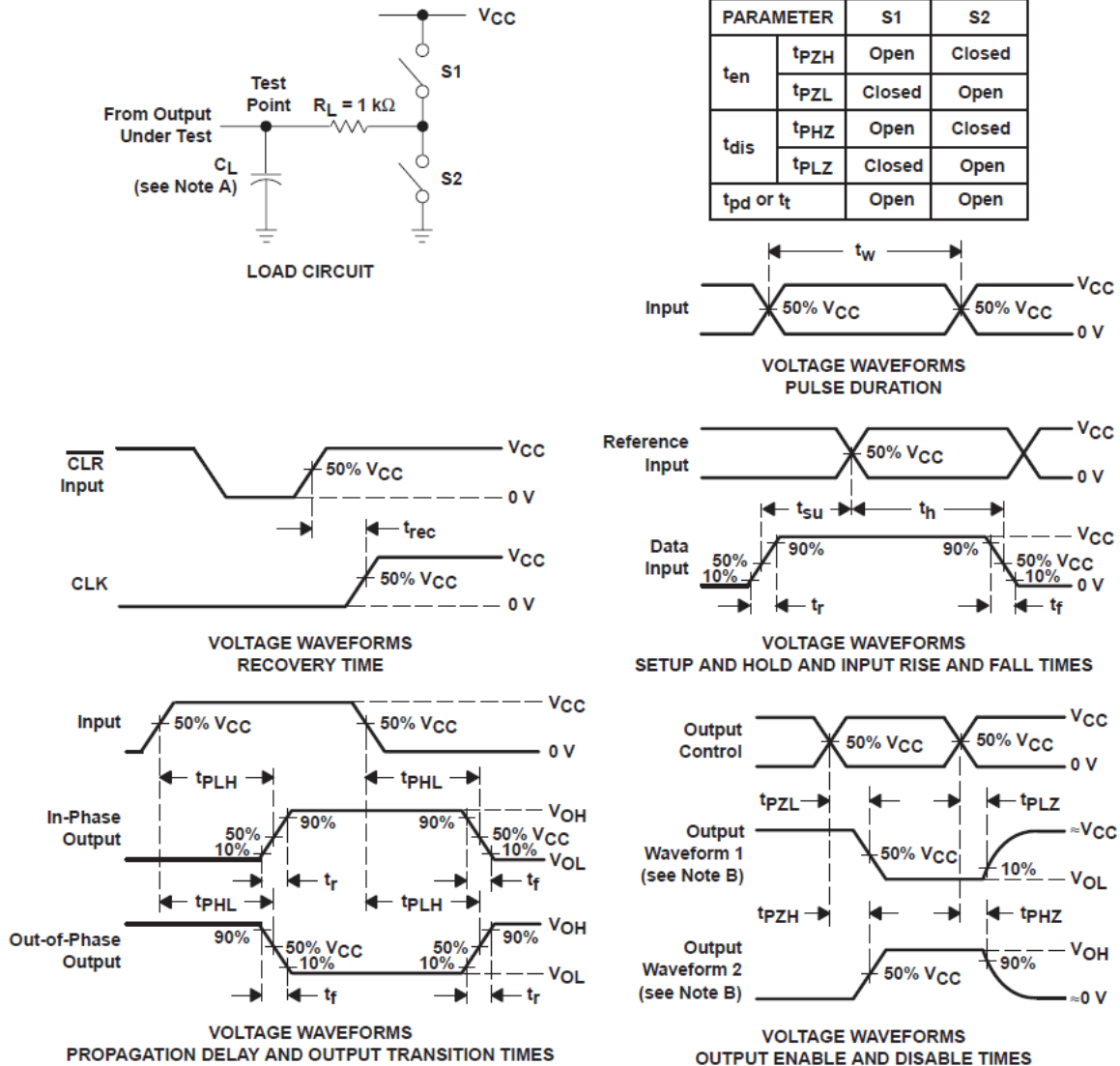

- NOTES: A. C_L includes probe and test-fixture capacitance.
 B. Waveform 1 is for an output with internal conditions such that the output is low except when disabled by the output control. Waveform 2 is for an output with internal conditions such that the output is high except when disabled by the output control.
 C. Phase relationships between waveforms were chosen arbitrarily. All input pulses are supplied by generators having the following characteristics: $PRR \leq 1$ MHz, $Z_O = 50 \Omega$, $t_r = 6$ ns, $t_f = 6$ ns.
 D. For clock inputs, f_{max} is measured with the input duty cycle at 50%.
 E. The outputs are measured one at a time with one input transition per measurement.
 F. t_{PLZ} and t_{PHZ} are the same as t_{dis} .
 G. t_{PZL} and t_{PZH} are the same as t_{en} .
 H. t_{PLH} and t_{PHL} are the same as t_{pd} .

 6-1. 'HC4511

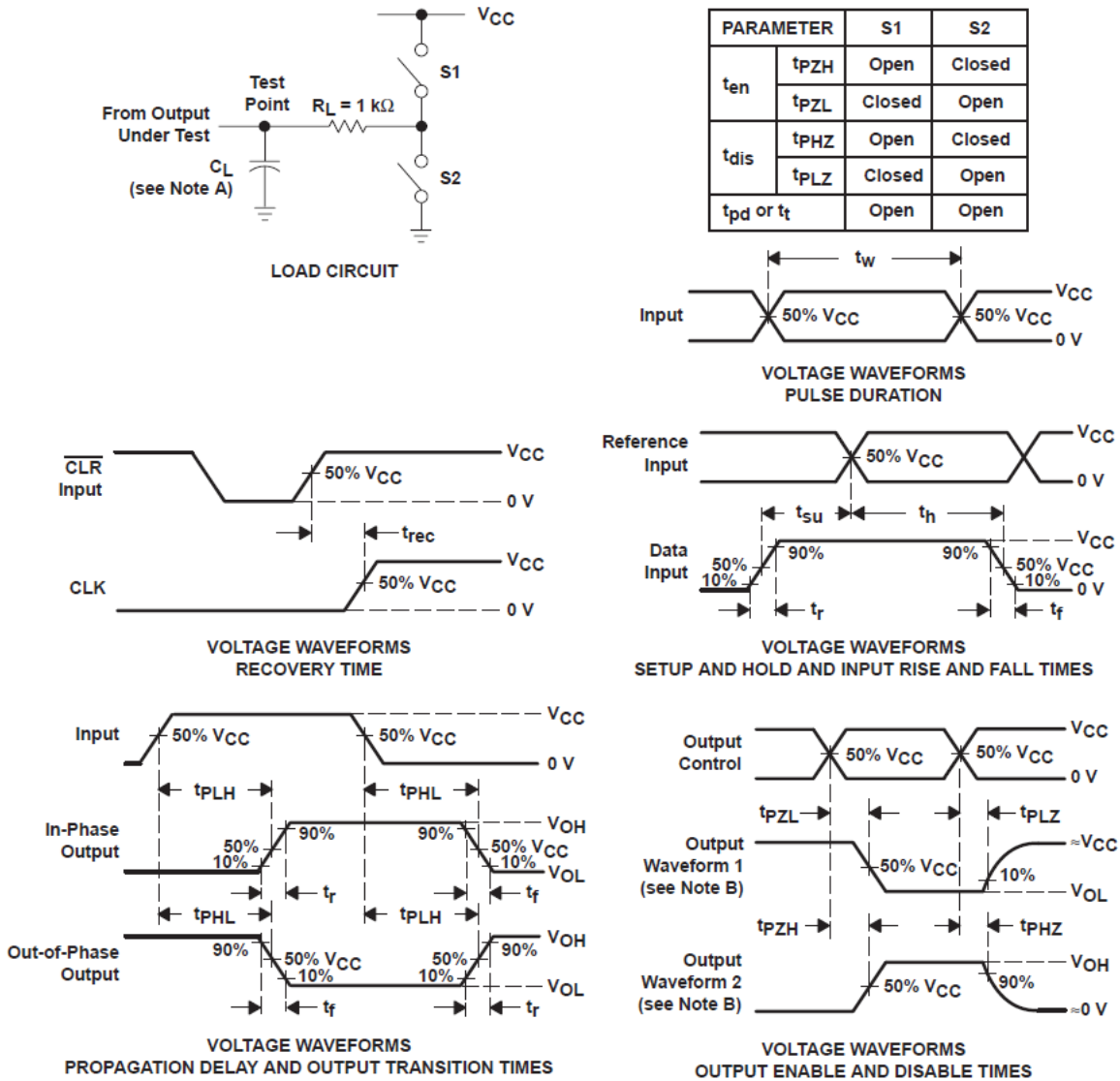

- NOTES: A. C_L includes probe and test-fixture capacitance.
 B. Waveform 1 is for an output with internal conditions such that the output is low except when disabled by the output control. Waveform 2 is for an output with internal conditions such that the output is high except when disabled by the output control.
 C. Phase relationships between waveforms were chosen arbitrarily. All input pulses are supplied by generators having the following characteristics: $PRR \leq 1\text{ MHz}$, $Z_O = 50\ \Omega$, $t_r = 6\text{ ns}$, $t_f = 6\text{ ns}$.
 D. For clock inputs, f_{max} is measured with the input duty cycle at 50%.
 E. The outputs are measured one at a time with one input transition per measurement.
 F. t_{PLZ} and t_{PHZ} are the same as t_{dis} .
 G. t_{PZL} and t_{PZH} are the same as t_{en} .
 H. t_{PLH} and t_{PHL} are the same as t_{pd} .

图 6-2. CD74HCT4511

7 Detailed Description

7.1 Overview

The CD54HC4511, CD74HC4511, and CD74HCT4511 are BCD-to-7 segment latch/decoder/drivers with four address inputs (D₀–D₃), an active-low blanking ($\overline{\text{BL}}$) input, lamp-test ($\overline{\text{LT}}$) input, and a latch-enable ($\overline{\text{LE}}$) input that, when high, enables the latches to store the BCD inputs. When $\overline{\text{LE}}$ is low, the latches are disabled, making the outputs transparent to the BCD inputs.

These devices have standard-size output transistors, but are capable of sourcing (at standard V_{OH} levels) up to 7.5 mA at 4.5 V. The HC types can supply up to 10 mA at 6 V.

7.2 Functional Block Diagram



图 7-1. Function Diagram

7.3 Device Functional Modes

表 7-1. Function Table

INPUTS ⁽¹⁾							OUTPUTS ⁽²⁾							
LE	$\overline{\text{BL}}$	LT	D ₃	D ₂	D ₁	D ₀	a	b	c	d	e	f	g	DISPLAY
X	X	L	X	X	X	X	H	H	H	H	H	H	H	8
X	L	H	X	X	X	X	L	L	L	L	L	L	L	Blank
L	H	H	L	L	L	L	H	H	H	H	H	H	L	0
L	H	H	L	L	L	H	L	H	H	L	L	L	L	1
L	H	H	L	L	H	L	H	H	L	H	H	L	H	2
L	H	H	L	L	H	H	H	H	H	H	L	L	H	3
L	H	H	L	H	L	L	L	H	H	L	L	H	H	4
L	H	H	L	H	L	H	H	L	H	H	L	H	H	5
L	H	H	L	H	H	L	L	L	H	H	H	H	H	6
L	H	H	L	H	H	H	H	H	H	L	L	L	L	7
L	H	H	H	L	L	L	H	H	H	H	H	H	H	8
L	H	H	H	L	L	H	H	H	H	L	L	H	H	9
L	H	H	H	L	H	L	L	L	L	L	L	L	L	Blank
L	H	H	H	L	H	H	L	L	L	L	L	L	L	Blank
L	H	H	H	H	L	L	L	L	L	L	L	L	L	Blank
L	H	H	H	H	L	H	L	L	L	L	L	L	L	Blank
L	H	H	H	H	H	H	L	L	L	L	L	L	L	Blank
L	H	H	H	H	H	H	L	L	L	L	L	L	L	Blank
H	H	H	X	X	X	X	t	t	t	t	t	t	t	t

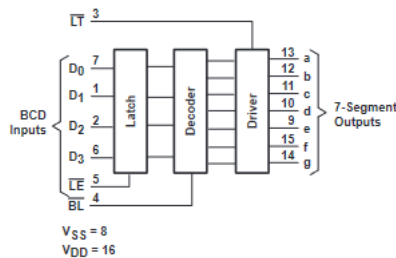
(1) H = High Voltage Level, L = Low Voltage Level, X = Don't care = Depends on BCD code previously applied when $\overline{\text{LE}}$ = LNOTE: Display is blank for all illegal input codes (BCD > HLLH).

(2) H = Driving High, L = Driving Low, Z = High Impedance State

8 Power Supply Recommendations

The power supply can be any voltage between the minimum and maximum supply voltage rating located in the *Recommended Operating Conditions*. Each V_{CC} terminal should have a good bypass capacitor to prevent power disturbance. A 0.1- μF capacitor is recommended for this device. It is acceptable to parallel multiple bypass caps to reject different frequencies of noise. The 0.1- μF and 1- μF capacitors are commonly used in parallel. The bypass capacitor should be installed as close to the power terminal as possible for best results.

9 Layout

9.1 Layout Guidelines

When using multiple-input and multiple-channel logic devices inputs must not ever be left floating. In many cases, functions or parts of functions of digital logic devices are unused; for example, when only two inputs of a triple-input AND gate are used or only 3 of the 4 buffer gates are used. Such unused input pins must not be left unconnected because the undefined voltages at the outside connections result in undefined operational states. All unused inputs of digital logic devices must be connected to a logic high or logic low voltage, as defined by the input voltage specifications, to prevent them from floating. The logic level that must be applied to any particular unused input depends on the function of the device. Generally, the inputs are tied to GND or V_{CC} , whichever makes more sense for the logic function or is more convenient.

10 Device and Documentation Support

TI offers an extensive line of development tools. Tools and software to evaluate the performance of the device, generate code, and develop solutions are listed below.

10.1 Receiving Notification of Documentation Updates

To receive notification of documentation updates, navigate to the device product folder on ti.com. Click on *Subscribe to updates* to register and receive a weekly digest of any product information that has changed. For change details, review the revision history included in any revised document.

10.2 サポート・リソース

TI E2E™ サポート・フォーラムは、エンジニアが検証済みの回答と設計に関するヒントをエキスパートから迅速かつ直接得ることができる場所です。既存の回答を検索したり、独自の質問をしたりすることで、設計に必要な支援を迅速に得ることができます。

リンクされているコンテンツは、該当する貢献者により、現状のまま提供されるものです。これらは TI の仕様を構成するものではなく、必ずしも TI の見解を反映したものではありません。TI の [使用条件](#) を参照してください。

10.3 Trademarks

TI E2E™ is a trademark of Texas Instruments.

すべての商標は、それぞれの所有者に帰属します。

10.4 Electrostatic Discharge Caution



This integrated circuit can be damaged by ESD. Texas Instruments recommends that all integrated circuits be handled with appropriate precautions. Failure to observe proper handling and installation procedures can cause damage.

ESD damage can range from subtle performance degradation to complete device failure. Precision integrated circuits may be more susceptible to damage because very small parametric changes could cause the device not to meet its published specifications.

10.5 Glossary

[TI Glossary](#) This glossary lists and explains terms, acronyms, and definitions.

11 Mechanical, Packaging, and Orderable Information

The following pages include mechanical, packaging, and orderable information. This information is the most current data available for the designated devices. This data is subject to change without notice and revision of this document. For browser-based versions of this data sheet, refer to the left-hand navigation.

11.1 Tape and Reel Information

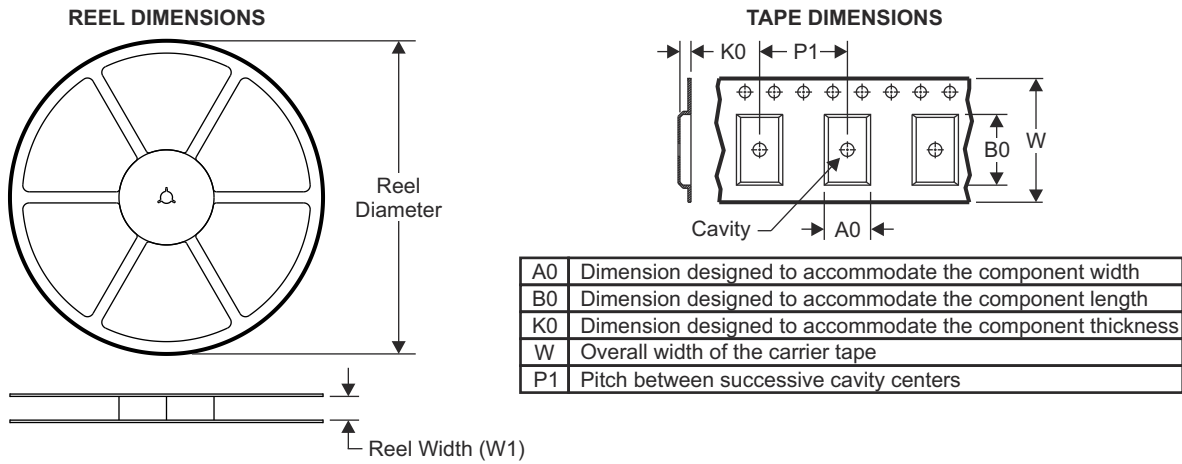

QUADRANT ASSIGNMENTS FOR PIN 1 ORIENTATION IN TAPE

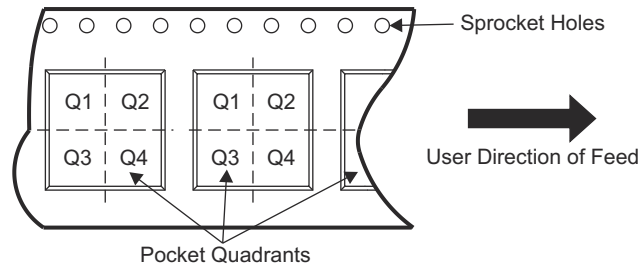

Device	Package Type	Package Drawing	Pins	SPQ	Reel Diameter (mm)	Reel Width W1 (mm)	A0 (mm)	B0 (mm)	K0 (mm)	P1 (mm)	W (mm)	Pin1 Quadrant
PTAS6584QDKQ1	HTQFP	PHD	64	1000	330.0	24.4	17.0	17.0	1.5	20.0	24.0	Q2

TAPE AND REEL BOX DIMENSIONS

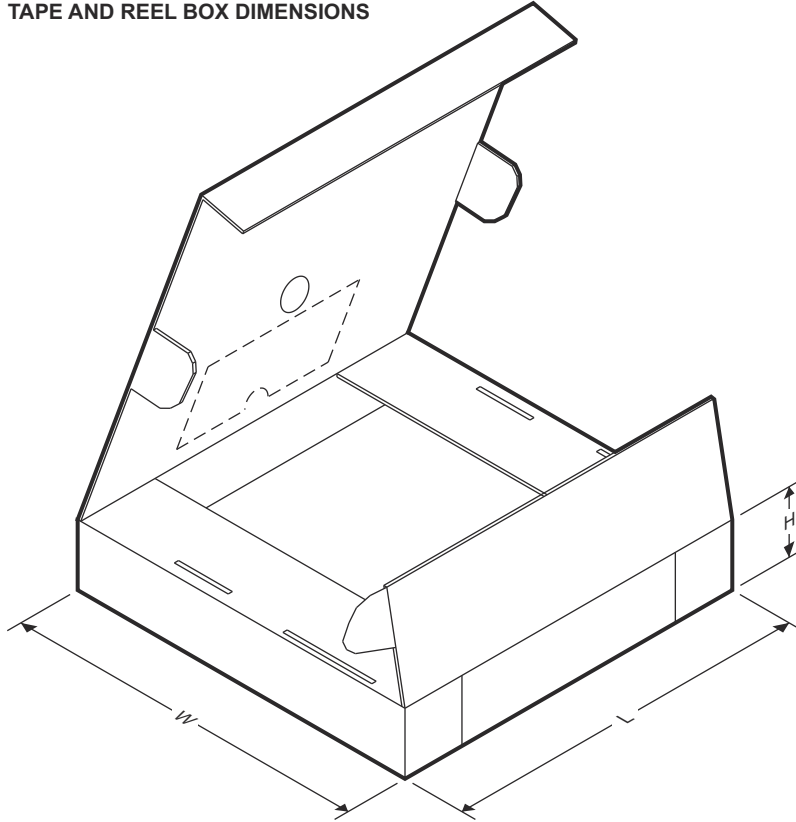

Device	Package Type	Package Drawing	Pins	SPQ	Length (mm)	Width (mm)	Height (mm)
PTAS6584QPHDRQ1	HTQFP	PHD	64	1000	350.0	350.0	43.0

11.2 Mechanical Data

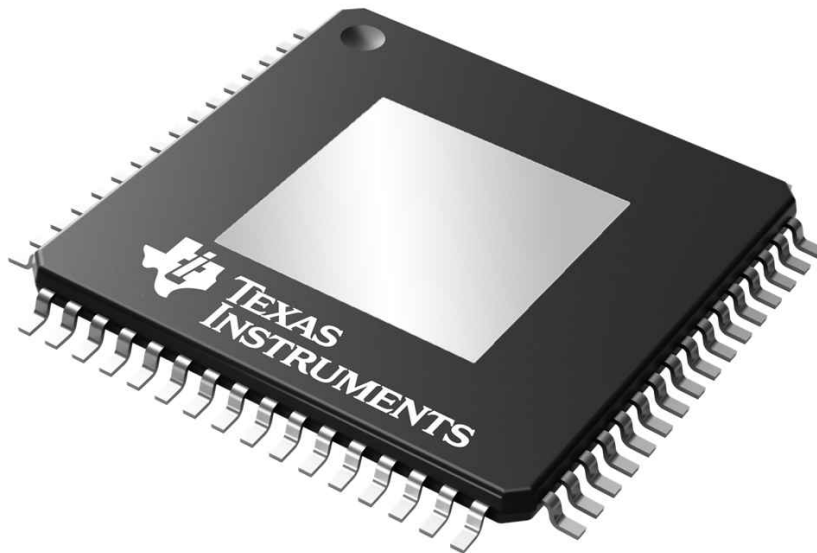

PACKAGE OUTLINE
HTQFP - 1.2 mm max height

PHD0064B

PLASTIC QUAD FLATPACK

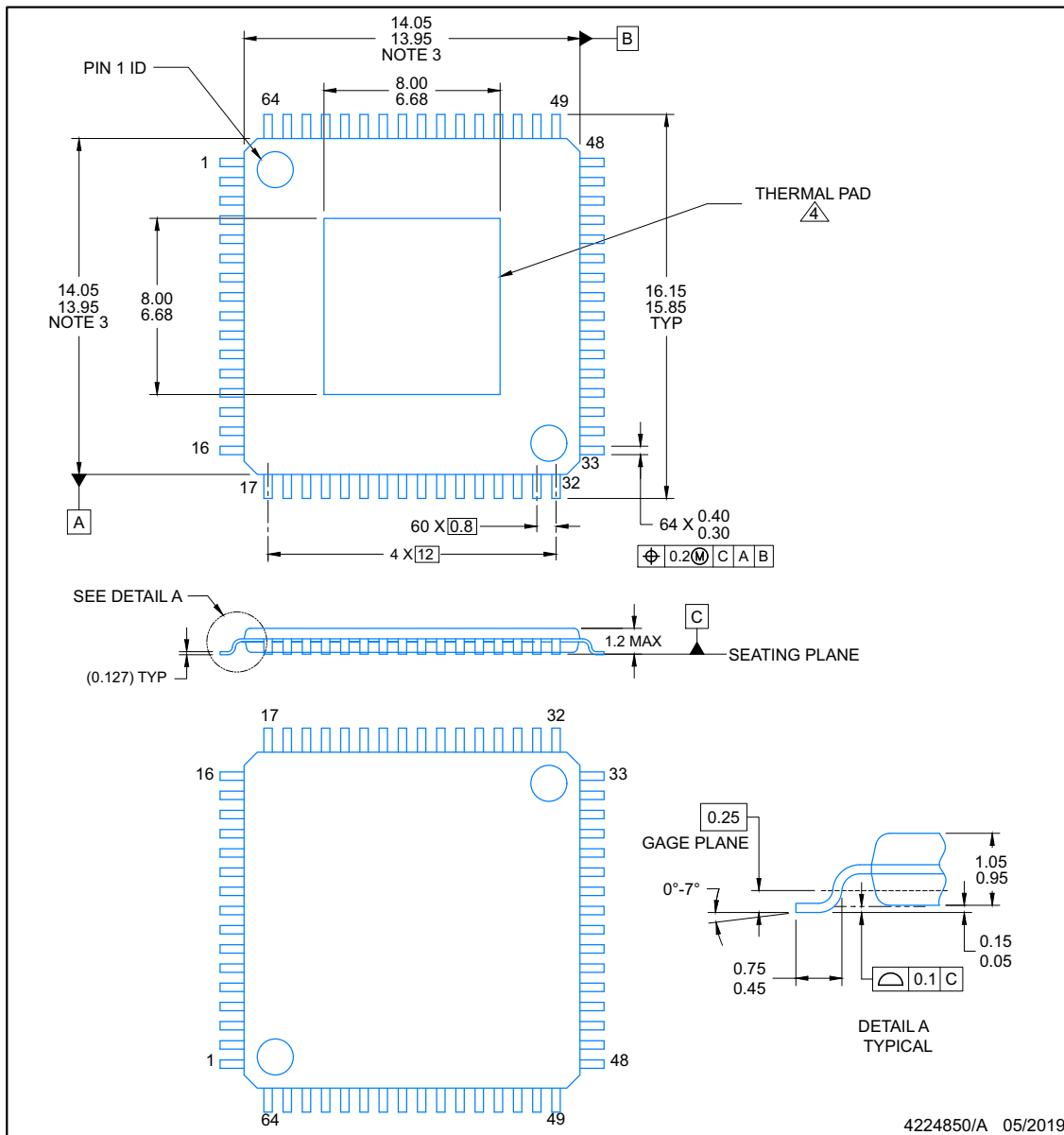

4224850/A 05/2019

NOTES:

1. All linear dimensions are in millimeters. Any dimensions in parenthesis are for reference only. Dimensioning and tolerancing per ASME Y14.5M.
2. This drawing is subject to change without notice.
3. This dimension does not include mold flash, protrusions, or gate burrs. Mold flash, protrusions, or gate burrs shall not exceed 0.15 per side.
4. See technical brief. PowerPad Thermally Enhanced Package, Texas Instruments Literature No. SLMA002 (www.ti.com/lit/slma002) and SLMA004 (www.ti.com/lit/slma004) for information regarding recommended board layout.

EXAMPLE BOARD LAYOUT
HTQFP - 1.2 mm max height

PHD0064B

PLASTIC QUAD FLATPACK

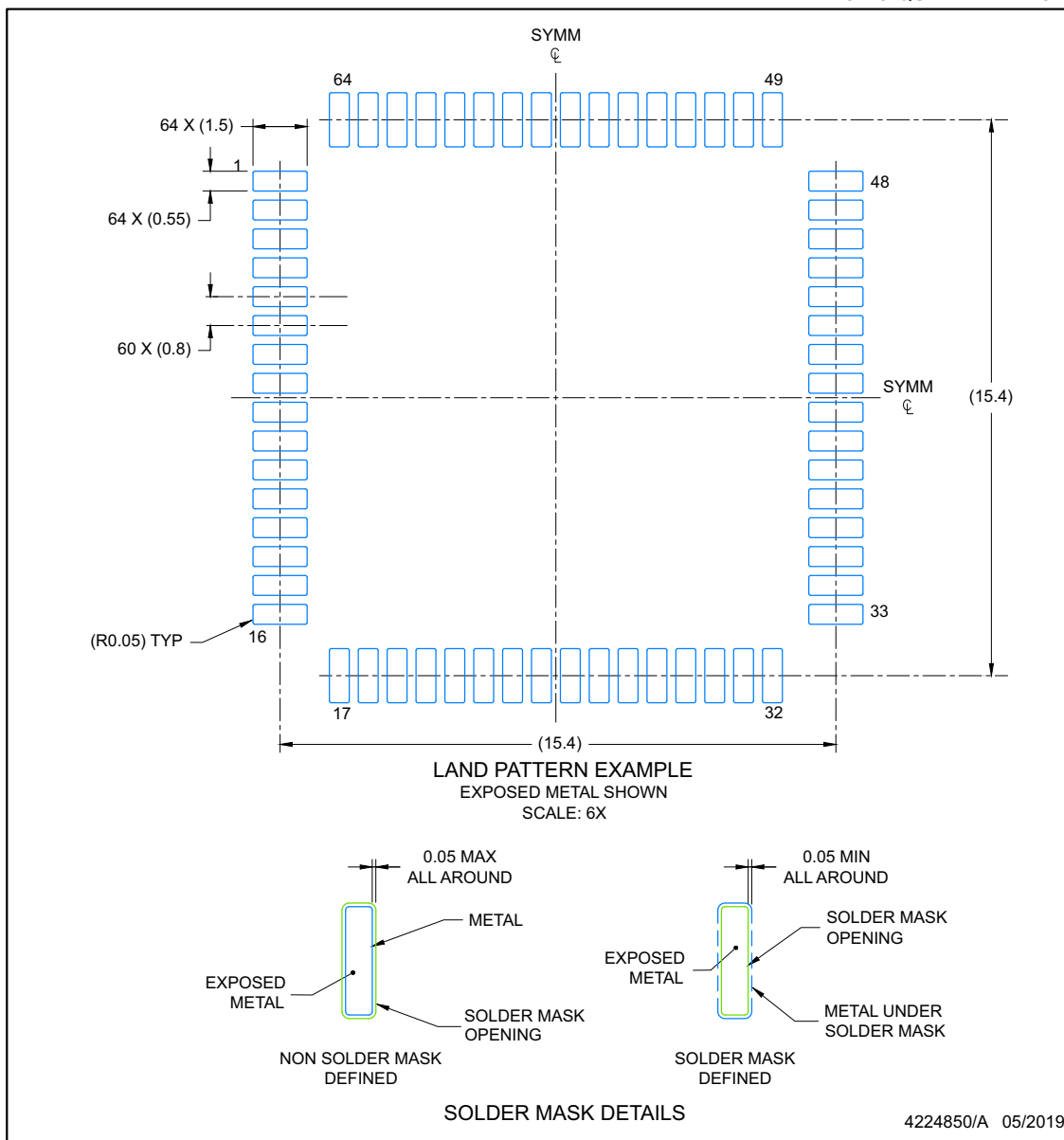

NOTES: (continued)

5. Publication IPC-7351 may have alternate designs.
6. Solder mask tolerances between and around signal pads can vary based on board fabrication site.
7. Vias are optional depending on application, refer to device data sheet. It is recommended that vias under paste be filled, plugged or tented.

EXAMPLE STENCIL DESIGN

PHD0064B

HTQFP - 1.2 mm max height

PLASTIC QUAD FLATPACK

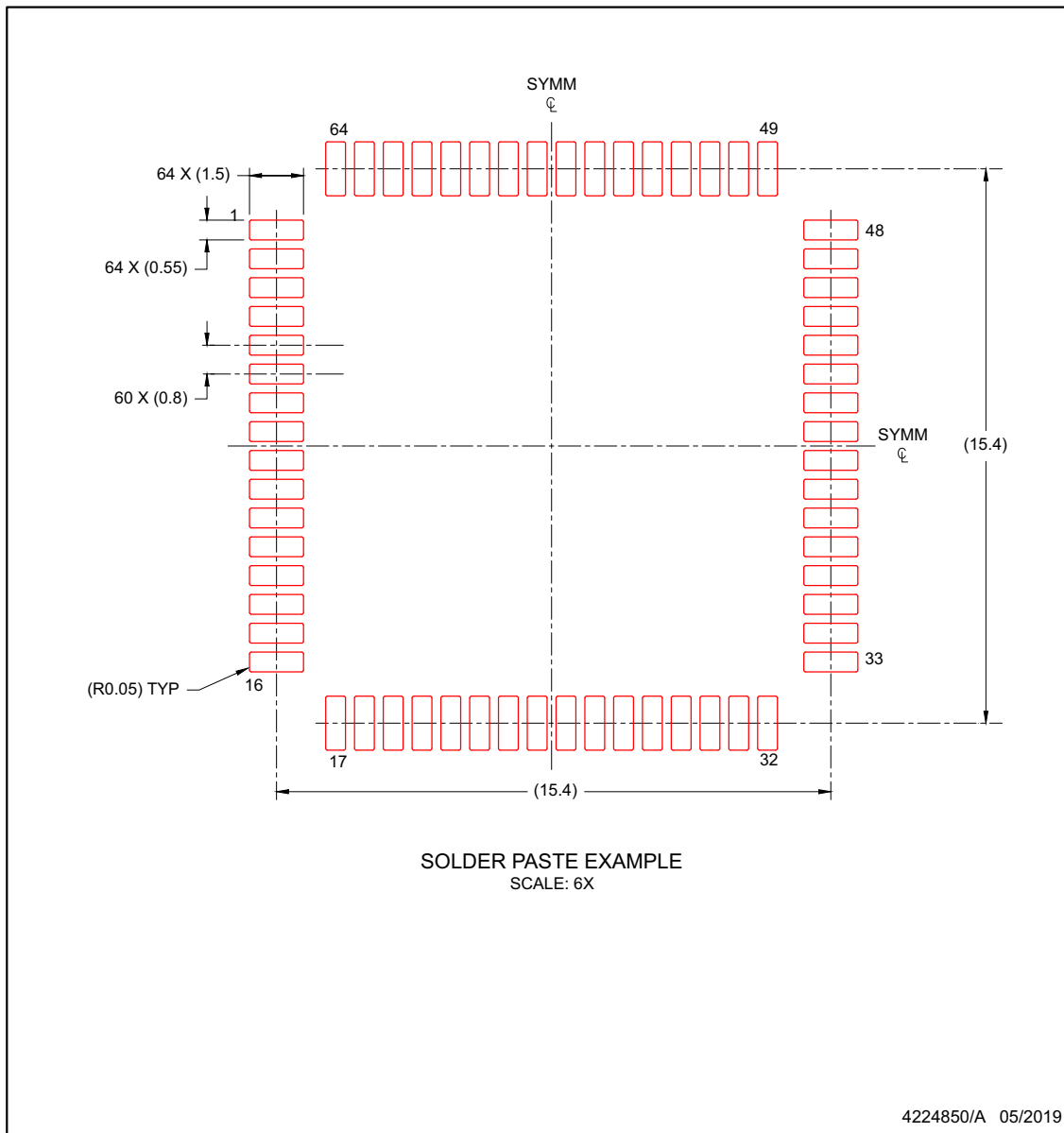

NOTES: (continued)

7. Laser cutting apertures with trapezoidal walls and rounded corners may offer better paste release. IPC-7525 may have alternate design recommendations.
8. Board assembly site may have different recommendations for stencil design.

PACKAGING INFORMATION

Orderable part number	Status (1)	Material type (2)	Package Pins	Package qty Carrier	RoHS (3)	Lead finish/ Ball material (4)	MSL rating/ Peak reflow (5)	Op temp (°C)	Part marking (6)
5962-8773301EA	Active	Production	CDIP (J) 16	25 TUBE	No	SNPB	N/A for Pkg Type	-55 to 125	5962-8773301EA CD54HC4511F3A
CD54HC4511F3A	Active	Production	CDIP (J) 16	25 TUBE	No	SNPB	N/A for Pkg Type	-55 to 125	5962-8773301EA CD54HC4511F3A
CD54HC4511F3A.A	Active	Production	CDIP (J) 16	25 TUBE	No	SNPB	N/A for Pkg Type	-55 to 125	5962-8773301EA CD54HC4511F3A
CD74HC4511E	Active	Production	PDIP (N) 16	25 TUBE	Yes	NIPDAU	N/A for Pkg Type	-55 to 125	CD74HC4511E
CD74HC4511E.A	Active	Production	PDIP (N) 16	25 TUBE	Yes	NIPDAU	N/A for Pkg Type	-55 to 125	CD74HC4511E
CD74HC4511EE4	Active	Production	PDIP (N) 16	25 TUBE	Yes	NIPDAU	N/A for Pkg Type	-55 to 125	CD74HC4511E
CD74HC4511M	Obsolete	Production	SOIC (D) 16	-	-	Call TI	Call TI	-55 to 125	HC4511M
CD74HC4511M96	Active	Production	SOIC (D) 16	2500 LARGE T&R	Yes	NIPDAU SN	Level-1-260C-UNLIM	-55 to 125	HC4511M
CD74HC4511M96.A	Active	Production	SOIC (D) 16	2500 LARGE T&R	Yes	NIPDAU	Level-1-260C-UNLIM	-55 to 125	HC4511M
CD74HC4511M96G4	Active	Production	SOIC (D) 16	2500 LARGE T&R	Yes	NIPDAU	Level-1-260C-UNLIM	-55 to 125	HC4511M
CD74HC4511M96G4.A	Active	Production	SOIC (D) 16	2500 LARGE T&R	Yes	NIPDAU	Level-1-260C-UNLIM	-55 to 125	HC4511M
CD74HC4511PWR	Active	Production	TSSOP (PW) 16	2000 LARGE T&R	Yes	NIPDAU	Level-1-260C-UNLIM	-55 to 125	HJ4511
CD74HC4511PWR.A	Active	Production	TSSOP (PW) 16	2000 LARGE T&R	Yes	NIPDAU	Level-1-260C-UNLIM	-55 to 125	HJ4511
CD74HC4511PWRE4	Active	Production	TSSOP (PW) 16	2000 LARGE T&R	Yes	NIPDAU	Level-1-260C-UNLIM	-55 to 125	HJ4511
CD74HC4511PWRG4	Active	Production	TSSOP (PW) 16	2000 LARGE T&R	Yes	NIPDAU	Level-1-260C-UNLIM	-55 to 125	HJ4511
CD74HC4511PWT	Obsolete	Production	TSSOP (PW) 16	-	-	Call TI	Call TI	-55 to 125	HJ4511
CD74HCT4511E	Active	Production	PDIP (N) 16	25 TUBE	Yes	NIPDAU	N/A for Pkg Type	-55 to 125	CD74HCT4511E
CD74HCT4511E.A	Active	Production	PDIP (N) 16	25 TUBE	Yes	NIPDAU	N/A for Pkg Type	-55 to 125	CD74HCT4511E

(1) **Status:** For more details on status, see our [product life cycle](#).

(2) **Material type:** When designated, preproduction parts are prototypes/experimental devices, and are not yet approved or released for full production. Testing and final process, including without limitation quality assurance, reliability performance testing, and/or process qualification, may not yet be complete, and this item is subject to further changes or possible discontinuation. If available for ordering, purchases will be subject to an additional waiver at checkout, and are intended for early internal evaluation purposes only. These items are sold without warranties of any kind.

(3) **RoHS values:** Yes, No, RoHS Exempt. See the [TI RoHS Statement](#) for additional information and value definition.

(4) **Lead finish/Ball material:** Parts may have multiple material finish options. Finish options are separated by a vertical ruled line. Lead finish/Ball material values may wrap to two lines if the finish value exceeds the maximum column width.

(5) **MSL rating/Peak reflow:** The moisture sensitivity level ratings and peak solder (reflow) temperatures. In the event that a part has multiple moisture sensitivity ratings, only the lowest level per JEDEC standards is shown. Refer to the shipping label for the actual reflow temperature that will be used to mount the part to the printed circuit board.

(6) **Part marking:** There may be an additional marking, which relates to the logo, the lot trace code information, or the environmental category of the part.

Multiple part markings will be inside parentheses. Only one part marking contained in parentheses and separated by a "~" will appear on a part. If a line is indented then it is a continuation of the previous line and the two combined represent the entire part marking for that device.

Important Information and Disclaimer: The information provided on this page represents TI's knowledge and belief as of the date that it is provided. TI bases its knowledge and belief on information provided by third parties, and makes no representation or warranty as to the accuracy of such information. Efforts are underway to better integrate information from third parties. TI has taken and continues to take reasonable steps to provide representative and accurate information but may not have conducted destructive testing or chemical analysis on incoming materials and chemicals. TI and TI suppliers consider certain information to be proprietary, and thus CAS numbers and other limited information may not be available for release.

In no event shall TI's liability arising out of such information exceed the total purchase price of the TI part(s) at issue in this document sold by TI to Customer on an annual basis.

OTHER QUALIFIED VERSIONS OF CD54HC4511, CD74HC4511 :

- Catalog : [CD74HC4511](#)
- Military : [CD54HC4511](#)

NOTE: Qualified Version Definitions:

- Catalog - TI's standard catalog product
- Military - QML certified for Military and Defense Applications

TAPE AND REEL INFORMATION

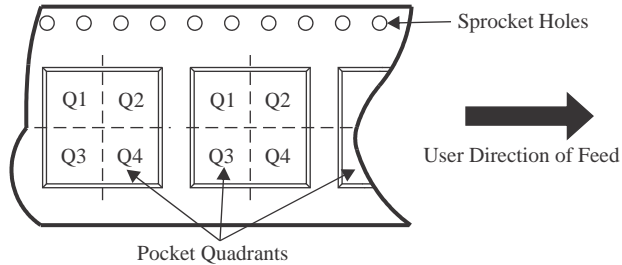
QUADRANT ASSIGNMENTS FOR PIN 1 ORIENTATION IN TAPE

*All dimensions are nominal

Device	Package Type	Package Drawing	Pins	SPQ	Reel Diameter (mm)	Reel Width W1 (mm)	A0 (mm)	B0 (mm)	K0 (mm)	P1 (mm)	W (mm)	Pin1 Quadrant
CD74HC4511M96	SOIC	D	16	2500	330.0	16.4	6.5	10.3	2.1	8.0	16.0	Q1
CD74HC4511M96G4	SOIC	D	16	2500	330.0	16.4	6.5	10.3	2.1	8.0	16.0	Q1
CD74HC4511PWR	TSSOP	PW	16	2000	330.0	12.4	6.9	5.6	1.6	8.0	12.0	Q1

TAPE AND REEL BOX DIMENSIONS

*All dimensions are nominal

Device	Package Type	Package Drawing	Pins	SPQ	Length (mm)	Width (mm)	Height (mm)
CD74HC4511M96	SOIC	D	16	2500	353.0	353.0	32.0
CD74HC4511M96G4	SOIC	D	16	2500	353.0	353.0	32.0
CD74HC4511PWR	TSSOP	PW	16	2000	353.0	353.0	32.0

TUBE

*All dimensions are nominal

Device	Package Name	Package Type	Pins	SPQ	L (mm)	W (mm)	T (μm)	B (mm)
CD74HC4511E	N	PDIP	16	25	506	13.97	11230	4.32
CD74HC4511E	N	PDIP	16	25	506	13.97	11230	4.32
CD74HC4511E.A	N	PDIP	16	25	506	13.97	11230	4.32
CD74HC4511E.A	N	PDIP	16	25	506	13.97	11230	4.32
CD74HC4511EE4	N	PDIP	16	25	506	13.97	11230	4.32
CD74HC4511EE4	N	PDIP	16	25	506	13.97	11230	4.32
CD74HCT4511E	N	PDIP	16	25	506	13.97	11230	4.32
CD74HCT4511E	N	PDIP	16	25	506	13.97	11230	4.32
CD74HCT4511E.A	N	PDIP	16	25	506	13.97	11230	4.32
CD74HCT4511E.A	N	PDIP	16	25	506	13.97	11230	4.32

D (R-PDSO-G16)

PLASTIC SMALL OUTLINE



- NOTES:
- A. All linear dimensions are in inches (millimeters).
 - B. This drawing is subject to change without notice.
 - C. Body length does not include mold flash, protrusions, or gate burrs. Mold flash, protrusions, or gate burrs shall not exceed 0.006 (0,15) each side.
 - D. Body width does not include interlead flash. Interlead flash shall not exceed 0.017 (0,43) each side.
 - E. Reference JEDEC MS-012 variation AC.

J (R-GDIP-T**)

14 LEADS SHOWN

CERAMIC DUAL IN-LINE PACKAGE



DIM \ PINS **	14	16	18	20
A	0.300 (7,62) BSC	0.300 (7,62) BSC	0.300 (7,62) BSC	0.300 (7,62) BSC
B MAX	0.785 (19,94)	.840 (21,34)	0.960 (24,38)	1.060 (26,92)
B MIN	—	—	—	—
C MAX	0.300 (7,62)	0.300 (7,62)	0.310 (7,87)	0.300 (7,62)
C MIN	0.245 (6,22)	0.245 (6,22)	0.220 (5,59)	0.245 (6,22)



4040083/F 03/03

- NOTES:
- All linear dimensions are in inches (millimeters).
 - This drawing is subject to change without notice.
 - This package is hermetically sealed with a ceramic lid using glass frit.
 - Index point is provided on cap for terminal identification only on press ceramic glass frit seal only.
 - Falls within MIL STD 1835 GDIP1-T14, GDIP1-T16, GDIP1-T18 and GDIP1-T20.

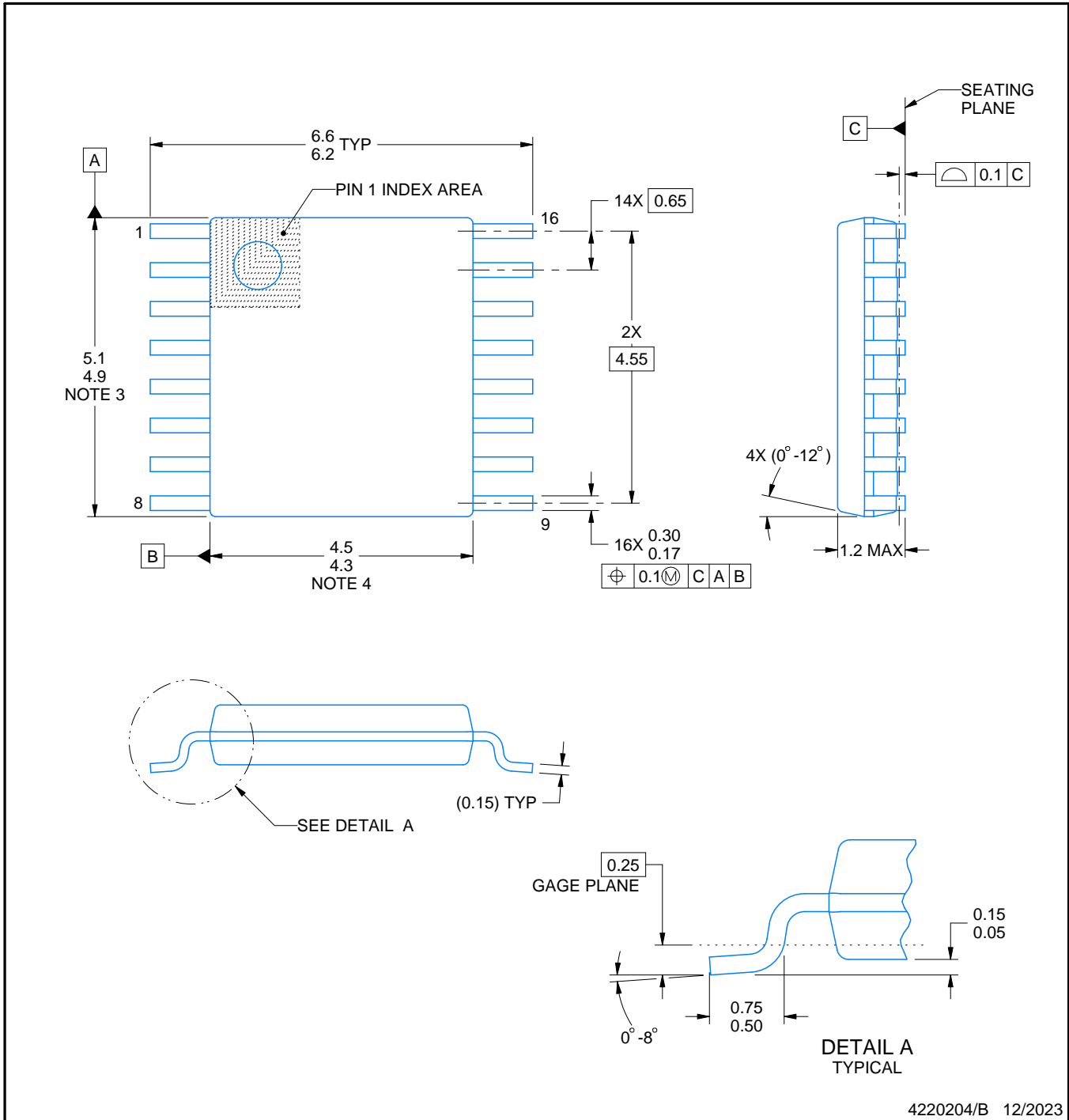

4220204/B 12/2023

NOTES:

1. All linear dimensions are in millimeters. Any dimensions in parenthesis are for reference only. Dimensioning and tolerancing per ASME Y14.5M.
2. This drawing is subject to change without notice.
3. This dimension does not include mold flash, protrusions, or gate burrs. Mold flash, protrusions, or gate burrs shall not exceed 0.15 mm per side.
4. This dimension does not include interlead flash. Interlead flash shall not exceed 0.25 mm per side.
5. Reference JEDEC registration MO-153.

EXAMPLE BOARD LAYOUT

PW0016A

TSSOP - 1.2 mm max height

SMALL OUTLINE PACKAGE



LAND PATTERN EXAMPLE
EXPOSED METAL SHOWN
SCALE: 10X

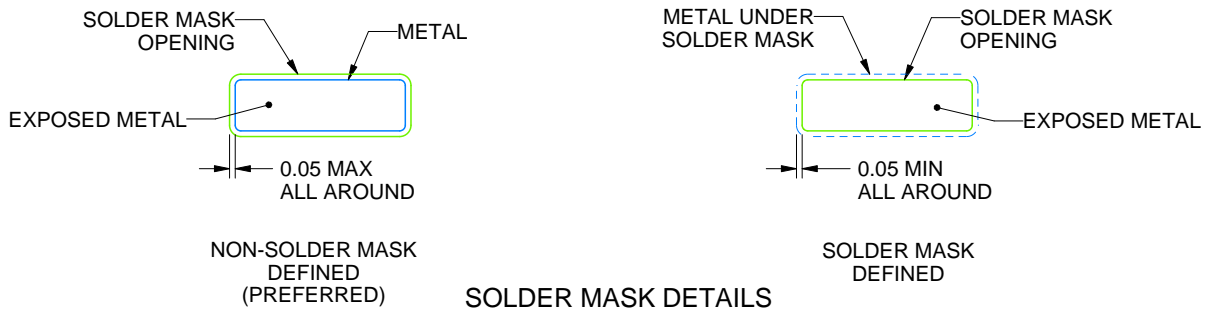

4220204/B 12/2023

NOTES: (continued)

6. Publication IPC-7351 may have alternate designs.
7. Solder mask tolerances between and around signal pads can vary based on board fabrication site.

EXAMPLE STENCIL DESIGN

PW0016A

TSSOP - 1.2 mm max height

SMALL OUTLINE PACKAGE



SOLDER PASTE EXAMPLE
BASED ON 0.125 mm THICK STENCIL
SCALE: 10X

4220204/B 12/2023

NOTES: (continued)

8. Laser cutting apertures with trapezoidal walls and rounded corners may offer better paste release. IPC-7525 may have alternate design recommendations.
9. Board assembly site may have different recommendations for stencil design.

N (R-PDIP-T**)

PLASTIC DUAL-IN-LINE PACKAGE

16 PINS SHOWN



4040049/E 12/2002

- NOTES:
- A. All linear dimensions are in inches (millimeters).
 - B. This drawing is subject to change without notice.
 - $\triangle C$ Falls within JEDEC MS-001, except 18 and 20 pin minimum body length (Dim A).
 - $\triangle D$ The 20 pin end lead shoulder width is a vendor option, either half or full width.

重要なお知らせと免責事項

TI は、技術データと信頼性データ (データシートを含みます)、設計リソース (リファレンス デザインを含みます)、アプリケーションや設計に関する各種アドバイス、Web ツール、安全性情報、その他のリソースを、欠陥が存在する可能性のある「現状のまま」提供しており、商品性および特定目的に対する適合性の黙示保証、第三者の知的財産権の非侵害保証を含むいかなる保証も、明示的または黙示的にかかわらず拒否します。

これらのリソースは、TI 製品を使用する設計の経験を積んだ開発者への提供を意図したものです。(1) お客様のアプリケーションに適した TI 製品の選定、(2) お客様のアプリケーションの設計、検証、試験、(3) お客様のアプリケーションに該当する各種規格や、その他のあらゆる安全性、セキュリティ、規制、または他の要件への確実な適合に関する責任を、お客様のみが単独で負うものとし、

上記の各種リソースは、予告なく変更される可能性があります。これらのリソースは、リソースで説明されている TI 製品を使用するアプリケーションの開発の目的でのみ、TI はその使用をお客様に許諾します。これらのリソースに関して、他の目的で複製することや掲載することは禁止されています。TI や第三者の知的財産権のライセンスが付与されている訳ではありません。お客様は、これらのリソースを自身で使用した結果発生するあらゆる申し立て、損害、費用、損失、責任について、TI およびその代理人を完全に補償するものとし、TI は一切の責任を拒否します。

TI の製品は、[TI の販売条件](#)、[TI の総合的な品質ガイドライン](#)、[ti.com](#) または TI 製品などに関連して提供される他の適用条件に従い提供されます。TI がこれらのリソースを提供することは、適用される TI の保証または他の保証の放棄の拡大や変更を意味するものではありません。TI がカスタム、またはカスタマー仕様として明示的に指定していない限り、TI の製品は標準的なカタログに掲載される汎用機器です。

お客様がいかなる追加条項または代替条項を提案する場合も、TI はそれらに異議を唱え、拒否します。

Copyright © 2026, Texas Instruments Incorporated

最終更新日 : 2025 年 10 月